

FCC PART 22/24 TEST REPORT
for
Wireless Medical Alarm System
Model No.: Mxx-xxxxx Series(x=0~9, A~Z or blank)
FCC ID: GX9MX

of

Applicant: **CLIMAX TECHNOLOGY CO., LTD.**
Address: **No. 258, Sinhu 2nd Rd., Neihu District, Taipei City 114**
Taiwan (R.O.C.)

Tested and Prepared

by

Worldwide Testing Services (Taiwan) Co., Ltd.

FCC Registration No.: 930600

Industry Canada filed test laboratory Reg. No. IC 5679A-1

A2LA Accredited No.: 2732.01



Report No.: W6M21308-13443-P2224

6F, NO. 58, LANE 188, RUEY-KUANG RD., NEIHU TAIPEI 114, TAIWAN, R.O.C.
TEL: 886-2-66068877 FAX: 886-2-66068879 E-mail: wts@wts-lab.com



Worldwide Testing Services(Taiwan) Co., Ltd.

Report Number: W6M21308-13443-P-2224
FCC ID: GX9MX

Certification of Test Report

Applicant : CLIMAX TECHNOLOGY CO., LTD.
No. 258, Sinhu 2nd Rd., Neihu District Taipei City 114
Taiwan (R.O.C.)
Manufacturer : CLIMAX TECHNOLOGY CO., LTD.
No. 258, Sinhu 2nd Rd., Neihu District Taipei City 114
Taiwan (R.O.C.)

Tested Equipment :
Type Description : Wireless Medical Alarm System
Model Number : Mxx-xxxxx Series(x=0~9, A~Z or blank)
Brand Name : CLIMAX
Operation Frequency : 824.2-848.8MHz / 1850.2 - 1909.8 MHz
WCDMA BAND II: 1852.4 – 1907.6 MHz
WCDMA BAND V : 826.4-846.6 MHz
RF Output Power: 1) Band 850 MHz : 29.07 dBm (ERP)
2) Band 1900 MHz : 32.08 dBm (EIRP)
3) BAND II : 25.50 dBm (EIRP)
4) BAND V : 17.16 dBm (ERP)
Power Supply : Adaptor: (I/P: 100-240V, 50-60Hz, 0.6A; O/P: 12V, 2A)
Battery: 7.2Vdc, 1600mAh

Regulation Applied : 47CFR Part 22 (2011-10) and Part 24 (2011-10)

Test Method : 47CFR Part 2 (2011), TIA/EIA-603C (2004) and
ANSI C63.4 (2003)

I HEREBY CERTIFY THAT: The test results written in this report were derived conscientiously in accordance with the requirements and procedures of 47CFR Part 2(2011), TIA/EIA-603C (2004), and it was found that the device described above is in compliance with the applicable limits specified in 47CFR Part 22/24.

Note:

1. The result of this test report is valid only in connection to the sample has been tested at the laboratory of Worldwide Testing Services (Taiwan) Co. Ltd.
2. This test report shall always be duplicated in full pages unless the written approval of the testing laboratory is obtained.

Test Engineer:

September 25, 2013

Rick Chen

Date

WTS-Lab.

Name

Signature

Technical responsibility for area of testing:

September 25, 2013

Kevin Wang

Date

WTS

Name

Signature

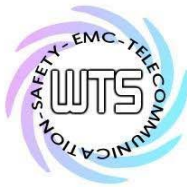

Report Number: W6M21308-13443-P-2224

FCC ID: GX9MX

TABLE OF CONTENTS

1. SUMMARY3

1.1 DESCRIPTION OF TESTED EQUIPMENT3

1.2 DATE OF TESTING PROCESSING3

1.3 MODIFICATION INFORMATION3

1.4 TEST STANDARDS.....3

1.5 SUMMARY OF TEST RESULT4

2. GENERAL INFORMATION.....5

2.1 TESTING LABORATORY5

2.1.1 *Location*5

2.1.2 *Details of accreditation status*5

2.1.3 *Test location, where different from Worldwide Testing Services (Taiwan) Co., Ltd.*5

2.2 DETAILS OF APPROVAL HOLDER.....5

2.3 DESCRIPTION OF TESTED SYSTEM.....6

2.4 TEST ENVIRONMENT7

2.5 GENERAL TEST REQUIREMENT7

2.6 TEST EQUIPMENT LIST8

3. RF POWER OUTPUT10

3.1 TEST PROCEDURE.....10

3.1.1 *Conducted Method*.....10

3.1.2 *Radiated Method*.....10

3.2 TEST RESULTS12

4. MODULATION CHARACTERISTICS26

4.1 TEST PROCEDURE.....26

4.2 TEST RESULTS26

5. OCCUPIED BANDWIDTH.....27

5.1 TEST PROCEDURE.....27

5.2 TEST RESULTS27

6. SPURIOUS EMISSIONS AT ANTENNA TERMINALS40

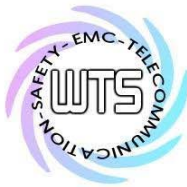

Report Number: W6M21308-13443-P-2224

FCC ID: GX9MX

6.1	TEST PROCEDURE.....	40
6.2	TEST RESULTS	40
6.3	EXPLANATION OF TEST RESULT.....	88
6.4	CALCULATION OF LIMIT FOR SPURIOUS AT ANTENNA TERMINALS.....	88
7.	FIELD STRENGTH OF SPURIOUS RADIATION.....	89
7.1	TEST PROCEDURE.....	89
7.2	TEST RESULTS	89
7.3	EXPLANATION OF TEST RESULT.....	108
7.4	CALCULATION OF LIMIT FOR FIELD STRENGTH OF SPURIOUS	108
7.5	TEST RESULT OF BAND EDGE EMISSIONS	109
8.	FREQUENCY STABILITY	112
8.1	TEST PROCEDURE.....	112
8.2	TEST RESULTS	113
8.2.1	<i>Frequency Stability vs. Temperature</i>	<i>113</i>
8.2.2	<i>Frequency Stability vs. Voltage</i>	<i>117</i>
9	MAXIMUM PERMISSIBLE EXPOSURE.....	120
9.1	APPLICABLE STANDARD	120
9.2	MPE CALCULATION METHOD	120
APPENDIX.....		122



Report Number: W6M21308-13443-P-2224

FCC ID: GX9MX

1. Summary

1.1 Description of tested equipment

This equipment under tested, Mxx-xxxxx Series(x=0~9, A~Z or blank), is a Wireless Medical Alarm System with built-in GSM 850/PCS 1900 MHz and supporting HSDPA and WCDMA.

The operation frequency bands and rated RF output power are listed as follows:

824.2-848.8MHz (Cellular, Part 22), 29.07 dBm / 0.8072 W (ERP)
1850.2-1909.8MHz (Cellular, Part 24), 32.08 dBm / 1.6144 W (EIRP)
Band II (Cellular, Part 24), 25.50 dBm / 0.3548 W (EIRP)
Band V (Cellular, Part 22), 17.16 dBm / 0.0519 W (ERP)

This test report only contains test requirements specified in 47CFR Part 22 and Part 24 for GSM function and WCDMA function, for other functions; please refer to separate test report with respect to the relevant test standard and specification.

1.2 Date of testing processing

Test sample received: August 15, 2013

Test finished: September 24, 2013

Other Information: None

1.3 Modification Information

No modification was made during the all test items been performed.

1.4 Test standards

Technical standard: **FCC Part 2(2011), TIA/EIA-603C (2004), ANSI C63.4(2003)
47CFR Part 22 (2011-10), and Part 24 (2011-10)**

Deviation from test standard: None

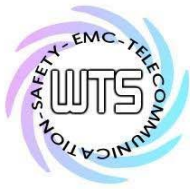

Report Number: W6M21308-13443-P-2224

FCC ID: GX9MX

1.5 Summary of test result

Band: 850 MHz & Band V

Section in this Report	Test Item	FCC relevant Section	Verdict
3.2	RF Power Output (Effective radiated power)	2.1046(a), 22.913(a)	Pass
4.2	Modulation characteristics	2.1047	Not Required
5.2	Occupied bandwidth	2.1049(h)	Pass
6.2	Spurious emissions at antenna terminals	22.917(a), 2.1051	Pass
7.2	Field strength of spurious radiation	22.917(a), 2.1053	Pass
7.5	Band Edge emissions	22.917(a)	Pass
8.2	Frequency stability	2.1055 22.355	Pass

Band: 1900 MHz & Band II

Section in this Report	Test Item	FCC Relevant Section	Verdict
3.2	RF Power Output (Equivalent isotropically radiated power)	2.1046(a), 24.232	Pass
4.2	Modulation characteristics	2.1047	Not Required
5.2	Occupied bandwidth	2.1049(h) 24.238(b)	Pass
6.2	Spurious emissions at antenna terminals	24.238(a), 2.1051	Pass
7.2	Field strength of spurious radiation	24.238(a), 2.1053	Pass
7.5	Band Edge emissions	24.238(b)	Pass
8.2	Frequency stability	2.1055 24.235	Pass

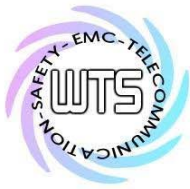

Report Number: W6M21308-13443-P-2224

FCC ID: GX9MX

2. General Information

2.1 Testing laboratory

2.1.1 Location

OATS
No.5-1, Shuang Sing Village,
LiShuei Rd., Wanli Township,
Taipei County 207, Taiwan (R.O.C.)
Company
Worldwide Testing Services (Taiwan) Co., Ltd.
6F, NO. 58, LANE 188, RUEY-KUANG RD.
NEIHU, TAIPEI 114, TAIWAN R.O.C.
Tel : 886-2-66068877
Fax : 886-2-66068879

2.1.2 Details of accreditation status

Accredited testing laboratory
A2LA-registration number: 2732.01
FCC filed test laboratory Reg. No. 930600
Industry Canada filed test laboratory Reg. No. IC 5679A-1



2.1.3 Test location, where different from Worldwide Testing Services (Taiwan) Co., Ltd.

Name: ./.
Accredited number: ./.
Street: ./.
Town: ./.
Country: ./.
Telephone: ./.
Fax: ./.

2.2 Details of approval holder

Name: CLIMAX TECHNOLOGY CO., LTD.
Street: No. 258, Sinhu 2nd Rd., Neihu District
Town: Taipei City 114
Country: Taiwan (R.O.C.)
Telephone: +886-2-2794-0001
Fax: +886-2-2792-6618



Report Number: W6M21308-13443-P-2224

FCC ID: GX9MX

Manufacturer: (if different from applicant)

Name: ./.
Street: ./.
Town: ./.
Country: ./.

2.3 Description of Tested System

The EUT was tested alone without the Accessories or Peripherals.

Equipment	Model No.	Series No.	Software	Cable information	Note
No accessories were used with this EUT.					

Frequencies Selected to be investigated:

Band: 850 MHz

Low Frequency (ch 128): 824.2 MHz
Mid Frequency (ch 188): 836.2 MHz
High Frequency (ch 251): 848.8 MHz

Band: 1900 MHz

Low Frequency (ch 512): 1850.2 MHz
Mid Frequency (ch 661): 1880.0 MHz
High Frequency (ch 810): 1909.8 MHz

WCDMA Band II

Low Frequency (ch 9262): 1852.4 MHz
Mid Frequency (ch 9400): 1880.0 MHz
High Frequency (ch 9538): 1907.6 MHz

WCDMA Band V

Low Frequency (ch 4132): 826.4 MHz
Mid Frequency (ch 4183): 836.6 MHz
High Frequency (ch 4233): 846.6 MHz

Antenna Type: GSM 850: PCB Antenna
PCS 1900: PCB Antenna
WCDMA Band II / Band V: PCB Antenna

Antenna Gain: GSM 850: -0.27 dBi
PCS 1900: -0.23 dBi
WCDMA Band II: -0.23 dBi / Band V: -0.27 dBi

Power supply: Adaptor: (I/P: 100-240V, 50-60Hz, 0.6A; O/P: 12V, 2A)
Battery: 7.2Vdc, 1600mAh

Special Statement:

1. This test report is valid in connection to the model has been tested, any modification to the product which is different from the test model will avoid the certification of the test report.
2. This test report shall always be duplicated in full pages unless the written approval of the testing laboratory is obtained.
3. The x in model number is representing different colors, printings on covered case and customers.

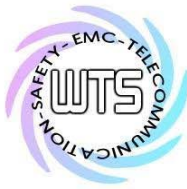

Report Number: W6M21308-13443-P-2224
FCC ID: GX9MX

2.4 Test environment

Temperature:	27 °C
Relative humidity content:	54 %
Air pressure:	86-103 Kpa

2.5 General Test Requirement

Radiated Emission: For investigated frequency is equal to or below 1GHz, the RBW and VBW of the spectrum analyzer was 100 kHz and 100 kHz respectively with an appropriate sweep speed.

For investigated frequency is above 1GHz, both of RBW and VBW of the spectrum analyzer were 1 MHz with an appropriate sweep speed. The analyzer was calibrated in dB above a microvolt at the output of the antenna.

The table used for radiated measurements is capable of continuous rotation. The spectrum was scanned from 30 MHz to the frequency specified as follows:

- (1) If the intentional radiator operates below 10 GHz: to the tenth harmonic of the highest fundamental frequency or to 40 GHz, whichever is lower.
- (2) If the intentional radiator operates at or above 10 GHz and below 30 GHz: to the fifth harmonic of the highest fundamental frequency or to 100 GHz, whichever is lower.
- (3) If the intentional radiator operates at or above 30 GHz: to the fifth harmonic of the highest fundamental frequency or to 200 GHz, whichever is lower, unless specified otherwise elsewhere in the rules.

For hand-held devices, a exploratory test was performed with three (3) orthogonal planes to determine the highest emissions.

When an emission was found, the table was rotated to produce the maximum signal strength. At this point, the antenna was raised and lowered from 1m to 4m. The antenna was placed in both the horizontal and vertical planes.

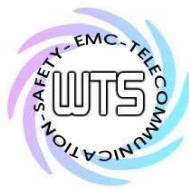

Report Number: W6M21308-13443-P-2224

FCC ID: GX9MX

2.6 Test Equipment List

No.	Test equipment	Type	Serial No.	Manufacturer	Cal. Date	Next Cal. Date
ETSTW-CE 001	EMI TEST RECEIVER	ESHS10	842121/013	R&S	2013/9/2	2014/9/1
ETSTW-CE 003	AC POWER SOURCE	APS-9102	D161137	GW	Function Test	
ETSTW-CE 004	ZWEILEITER-V-NETZNACHBILDUNG TWO-LINE V-NETWORK	ESH3-Z5	840731/011	R&S	2012/12/21	2013/12/20
ETSTW-CE 006	IMPULSBEGRENZER PULSE LIMITER	ESH3-Z2	100226	R&S	2013/3/4	2014/3/3
ETSTW-CE 007	SPECTRUM ANALYZER 5GHz	FSB	849670/001	R&S	Pre-test Use	
ETSTW-CE 008	HF-EICHLITUNG RF STEP ATTENUATOR 139dB DPSP	334.6010.02	844581/024	R&S	Function Test	
ETSTW-CE 009	TEMP.&HUMIDITY CHAMBER	GTH-225-40-1P-U	MAA0305-009	GIANT FORCE	2013/7/10	2014/7/9
ETSTW-RE 004	EMI TEST RECEIVER	ESI 40	832427/004	R&S	2013/9/2	2014/9/1
ETSTW-RE 005	EMI TEST RECEIVER	ESVS10	843207/020	R&S	2013/9/2	2014/9/1
ETSTW-RE 012	TUNABLE BANDREJECT FILTER	D.C 0309	146	K&L	Function Test	
ETSTW-RE 013	TUNABLE BANDREJECT FILTER	D.C 0336	397	K&L	Function Test	
ETSTW-RE 018	MICROWAVE HORN ANTENNA	AT4560	27212	AR	2012/10/12	2013/10/11
ETSTW-RE 027	Passive Loop Antenna	6512	00034563	ETS-Lindgren	2013/7/3	2014/7/2
ETSTW-RE 030	Double-Ridged Guide Horn Antenna	3117	00035224	EMCO	2013/3/4	2014/3/3
ETSTW-RE 045	ESA-E SERIES SPECTRUM ANALYZER	E4404B	MY45111242	Agilent	Pre-test Use	
ETSTW-RE 049	TRILOG Super Broadband test Antenna	VULB 9160	9160-3185	Schwarzbeck	2013/3/21	2014/3/20
ETSTW-RE 050	Attenuator 10dB	50HF-010-1	None	JFW	2013/3/4	2014/3/3
ETSTW-RE 051	Attenuator 6dB	50HF-006-1	None	JFW	2013/3/4	2014/3/3
ETSTW-RE 053	Attenuator 3dB	50HF-003-1	None	JFW	2013/3/4	2014/3/3
ETSTW-RE 055	SPECTRUM ANALYZER	FSU 26	200074	R&S	2013/5/31	2014/5/30
ETSTW-RE 060	Attenuator 30dB	5015-30	F651012z-01	ATM	2013/3/4	2014/3/3
ETSTW-RE 062	Amplifier Module	CHC 2	None	KMIC	2012/11/28	2013/11/27
ETSTW-RE 064	Bluetooth Test Set	MT8852B-042	6K00005709	Anritsu	Function Test	
ETSTW-RE 069	Double-Ridged Guide Horn Antenna	3117	00069377	EMCO	Function Test	
ETSTW-RE 072	CELL SITE TEST SET	8921A	3339A00375	HP	2012/10/5	2013/10/4
ETSTW-RE 088	SOLID STATE AMPLIFIER	KMA180265A01	99057	KMIC	2012/10/12	2013/10/11
ETSTW-RE 099	DC Block	50DB-007-1	None	JFW	2013/3/4	2014/3/3
ETSTW-RE 106	Humidity Temperature Meter	TES-1366	091011113	TES	2012/12/4	2013/12/3
ETSTW-RE 111	TRILOG Super Broadband test Antenna	VULB 9160	9160-3309	Schwarz beck	2012/12/13	2013/12/12
ETSTW-RE 112	AC POWER SOURCE	TFC-1005	None	T-Power	Function test	
ETSTW-RE 115	2.4GHz Notch Filter	N0124411	473874	MICROWAVE CIRCUITS	2013/1/11	2014/1/10
ETSTW-RE 120	RF Player	MP9200	MP9210-111022	ADIVIC	Function test	

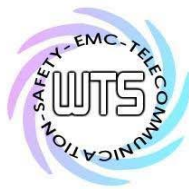

Worldwide Testing Services(Taiwan) Co., Ltd.

Report Number: W6M21308-13443-P-2224

FCC ID: GX9MX

ETSTW-RE 122	SIGNAL GENERATOR	SMF100A	102149	R&S	2013/6/28	2014/6/27
ETSTW-RE 125	5GHz Notch filter	5NSL11-5200/E221.3-O/O	1	K&L Microwave	2013/8/16	2014/8/15
ETSTW-RE 126	5GHz Notch filter	5NSL11-5800/E221.3-O/O	1	K&L Microwave	2013/8/16	2014/8/15
ETSTW-RE 127	RF Switch Box	RFS-01	None	WTS	2013/3/4	2014/3/3
ETSTW-RE 128	5.3GHz Notch filter	N0153001	SN487233	Microwave Circuits	2013/8/13	2014/8/12
ETSTW-RE 129	5.5GHz Notch filter	N0555984	SN487234	Microwave Circuits	2013/8/13	2014/8/12
ETSTW-GSM 002	Universal Radio Communication Tester	CMU 200	109439	R&S	2012/10/5	2013/10/4
ETSTW-GSM 019	Band Reject Filter	WRCTF824/849-822/851-40 /12+9SS	3	WI	2013/1/11	2014/1/10
ETSTW-GSM 020	Band Reject Filter	WRCD1747/1748-1743/1752-32/5SS	1	WI	2013/1/11	2014/1/10
ETSTW-GSM 021	Band Reject Filter	WRCD1879.5/1880.5-1875.5/1884.5-32/5SS	3	WI	2013/1/11	2014/1/10
ETSTW-GSM 022	Band Reject Filter	WRCT901.9/903.1-904.25-50/8SS	1	WI	2013/1/11	2014/1/10
ETSTW-GSM 023	Power Divider	4901.19.A	None	SUHNER	2013/9/18	2014/9/17
ETSTW-Cable 010	BNC Cable	5 M BNC Cable	None	JYE BAO CO.,LTD.	2013/3/4	2014/3/3
ETSTW-Cable 011	BNC Cable	BNC Cable 1	None	JYE BAO CO.,LTD.	Pre-test Use NCR	
ETSTW-Cable 012	N TYPE To SMA Cable	Cable 012	None	JYE BAO CO.,LTD.	2013/3/4	2014/3/3
ETSTW-Cable 016	BNC Cable	Switch Box	B Cable 1	Schwarz beck	2013/3/4	2014/3/3
ETSTW-Cable 017	BNC Cable	X Cable	B Cable 2	Schwarz beck	2013/3/4	2014/3/3
ETSTW-Cable 018	BNC Cable	Y Cable	B Cable 3	Schwarz beck	2013/3/4	2014/3/3
ETSTW-Cable 019	BNC Cable	Z Cable	B Cable 4	Schwarz beck	2013/3/4	2014/3/3
ETSTW-Cable 022	N TYPE Cable	5006	0002	JYE BAO CO.,LTD.	2013/3/26	2014/3/25
ETSTW-Cable 026	Microwave Cable	SUCOFLEX 104	279075	HUBER+SUHNER	2013/3/4	2014/3/3
ETSTW-Cable 027	Microwave Cable	SUCOFLEX 104	279083	HUBER+SUHNER	2013/3/4	2014/3/3
ETSTW-Cable 028	Microwave Cable	FA147A0015M2020	30064-2	UTIFLEX	2012/10/12	2013/10/11
ETSTW-Cable 029	Microwave Cable	FA147A0015M2020	30064-3	UTIFLEX	2012/10/12	2013/10/11
ETSTW-Cable 030	Microwave Cable	SUCOFLEX 104 (S_Cable 9)	279067	HUBER+SUHNER	2013/3/4	2014/3/3
ETSTW-Cable 031	Microwave Cable	SUCOFLEX 104 (S_Cable 10)	238092	HUBER+SUHNER	2012/11/28	2013/11/27
ETSTW-Cable 043	Microwave Cable	SUCOFLEX 104	317576	HUBER+SUHNER	2012/11/28	2013/11/27
ETSTW-Cable 047	Microwave Cable	SUCOFLEX 104	325518	HUBER+SUHNER	2012/11/28	2013/11/27
ETSTW-Cable 053	N TYPE To SMA Cable	RG142	None	JYE BAO CO.,LTD.	2013/3/26	2014/3/25
ETSTW-Cable 058	Microwave Cable	SUCOFLEX 104	none	HUBER+SUHNER	2013/6/20	2014/6/19
WTSTW-SW 002	EMI TEST SOFTWARE	EZ EMC	None	Farad	Version ETS-03A1	

Report Number: W6M21308-13443-P-2224

FCC ID: GX9MX

3. RF Power Output

3.1 Test procedure

3.1.1 Conducted Method

Per 47CFR Part 2.1046, the RF power output shall be measured at the RF output terminals and following procedure is employed:

The transmitter output was connected as the following figure:

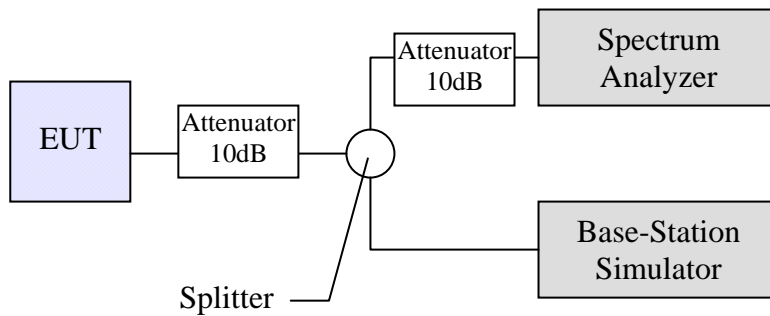

The whole connection system is calibrated with a standard signal generator. Power on and make a link from simulator to EUT and then set the EUT to maximum output power.

Measure the RF power with the spectrum analyzer in accordance the following settings:

RBW: 300 kHz for Frequency below 1GHz and 1MHz for Frequency equal to and above 1GHz.

VBW: 300 kHz for Frequency below 1GHz and 1MHz for Frequency equal to and above 1GHz.

Span: 2MHz

Sweep: 3s

The power output at the transmitter antenna terminal is then determined by assign the value of the corrected factor to the spectrum analyzer reading.

Tests were performed at three frequencies (low, middle and high channels) and operation mode selected.

3.1.2 Radiated Method

If the conducted measurement is not practical due to the integral antenna, the radiated measurement will be performed in accordance the following procedure:

The EUT was positioned on a non-conductive turntable, 0.8m above the ground on an open test site.

The radiated emission at the fundamental frequency was measured at 3m distance with a test antenna and spectrum analyzer.

Report Number: W6M21308-13443-P-2224

FCC ID: GX9MX

Worst case emission was recorded with the rotation of the turntable and the raising and lowering of the test antenna.

Substitution RF power Measurement at WTS Taiwan
General:

The applied substitution method follows ANSI/TIA/EIA-603, ANSI/TIA/EIA-102.CAAA or the appropriate ETSI rules respectively.

The actual signal generated by the EUT can be determined by means of a substitution measurement in which a known signal source replaces the device to be measured.

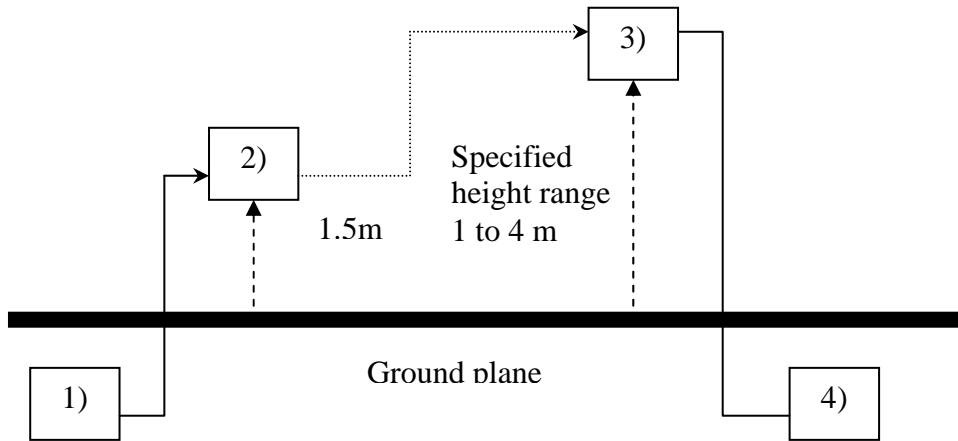

- 1) Signal generator;
- 2) Substitution antenna;
- 3) Test antenna;
- 4) Spectrum analyzer or selective voltmeter.

The substitution antenna replaces the transmitter antenna at the same position and in vertical polarization. The frequency of the signal generator shall be adjusted to the measurement frequency.

The test antenna shall be raised or lowered, if necessary, to ensure that the maximum signal is still received. The input signal to the substitution antenna shall be adjusted in level until an equal or a known related level to that detected from the transmitter is obtained in the measurement receiver.

If a fully anechoic chamber is used as test site in order to provide free space conditions there is no need to change the height of the antenna.

The measurement will be repeated in horizontal position.

Calibration:

In order to make this kind of measurement more effective and to avoid subjective measurement faults ETS has installed automatic computer controlled measurement procedures.

With the above described substitution method a test site is calibrated over the full frequency range which is used in suitable frequency steps. For a certain power level on the substitution antenna the received power over the whole frequency range is documented. All necessary antenna gains, cable losses, filter losses and amplifications of preamplifiers are taken in



Report Number: W6M21308-13443-P-2224
FCC ID: GX9MX

consideration. The summary of this calibration measurement performs a transducer factor that is related to the considered test site and a certain measurement distance. Differences of the radiated power levels of different test samples are determined by internal attenuation of measurement receiver. The proper function of such test site will be maintained by short term plausibility checks and periodical re-calibration.

Testing:

The test sample will be putted on the table at the defined position and the radiated power will be receiver and documented by the measurement receiver.

On test sites with ground plane the measurement antenna will be lowered and raised to maximum values at significant frequencies.

For peak power measurements the sample is turned by the turntable over 360 degree in order to find the direction with the maximum radiation or to document the max reading with the MAXHOLD function during the rotation.

3.2 Test Results

- Conducted Measurement
- Radiated Measurement

Band 850 MHz & 1900MHz
7 V

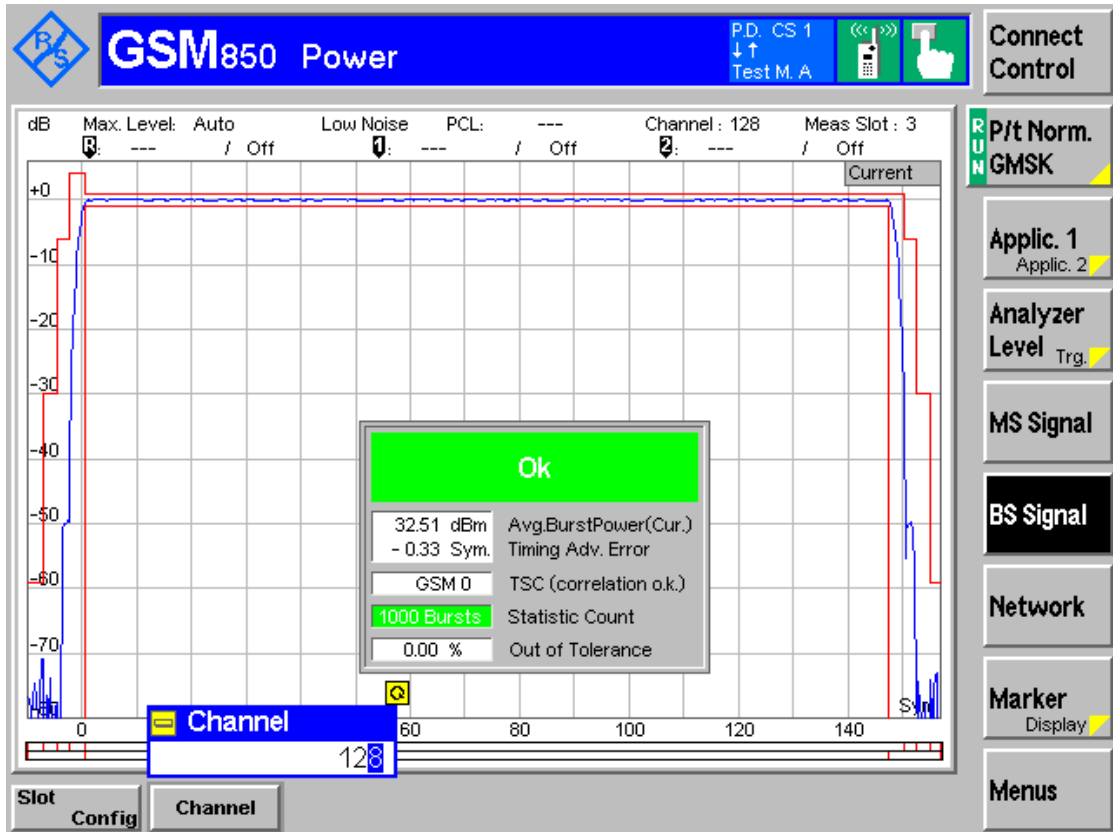

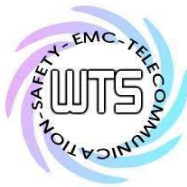

Worldwide Testing Services(Taiwan) Co., Ltd.

Report Number: W6M21308-13443-P-2224
FCC ID: GX9MX

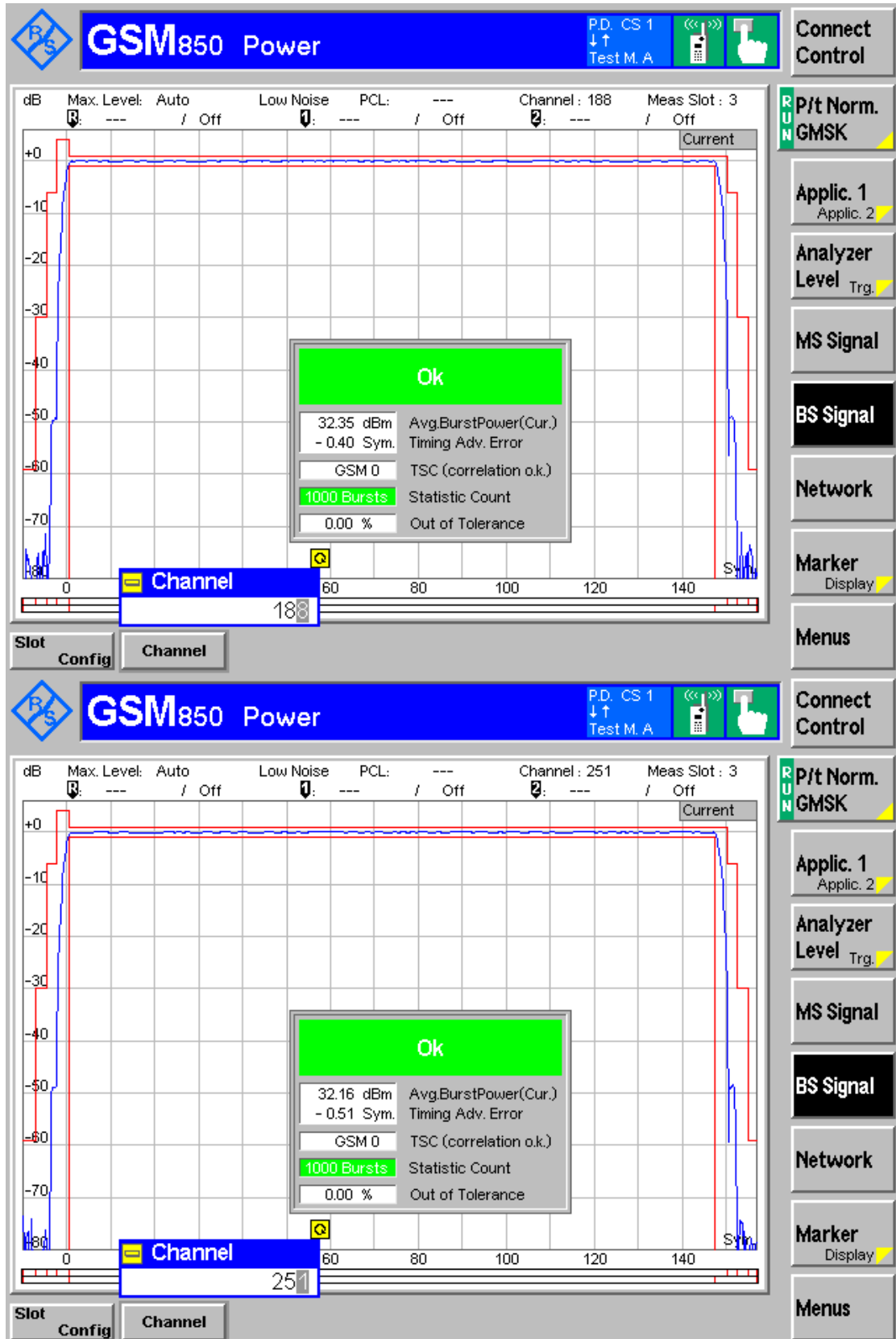

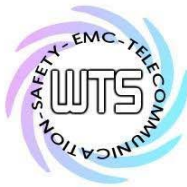

Report Number: W6M21308-13443-P-2224
FCC ID: GX9MX

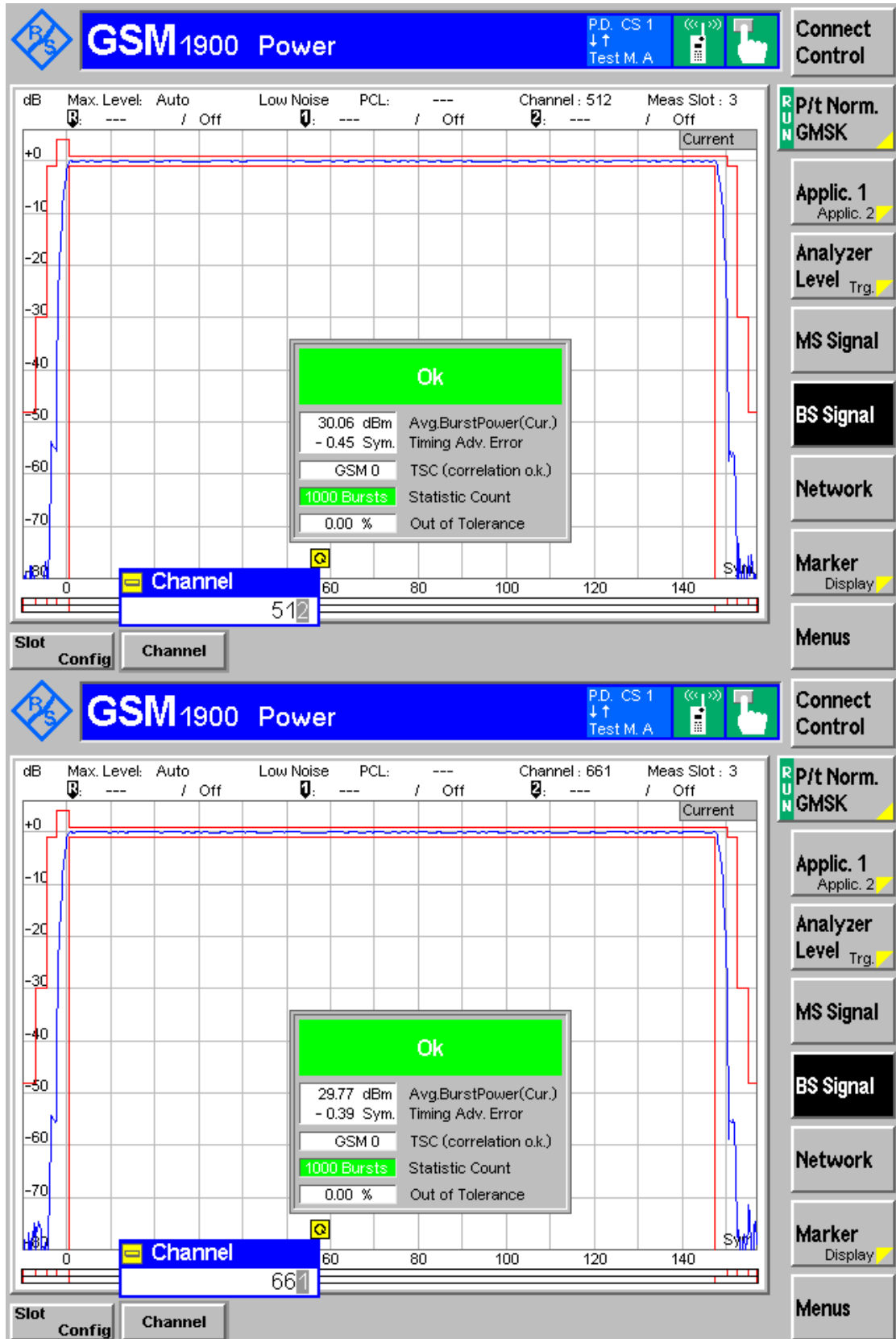

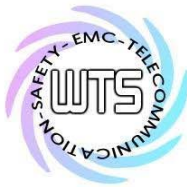

Report Number: W6M21308-13443-P-2224
FCC ID: GX9MX

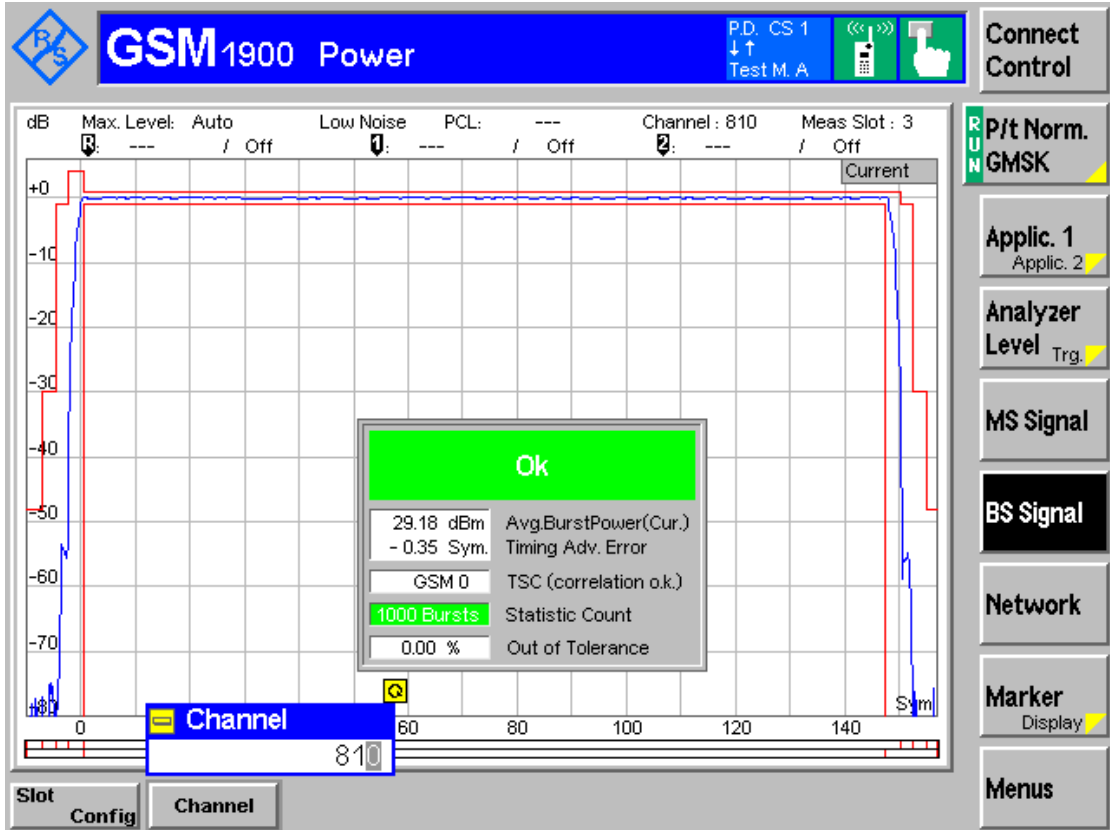

7.92 V

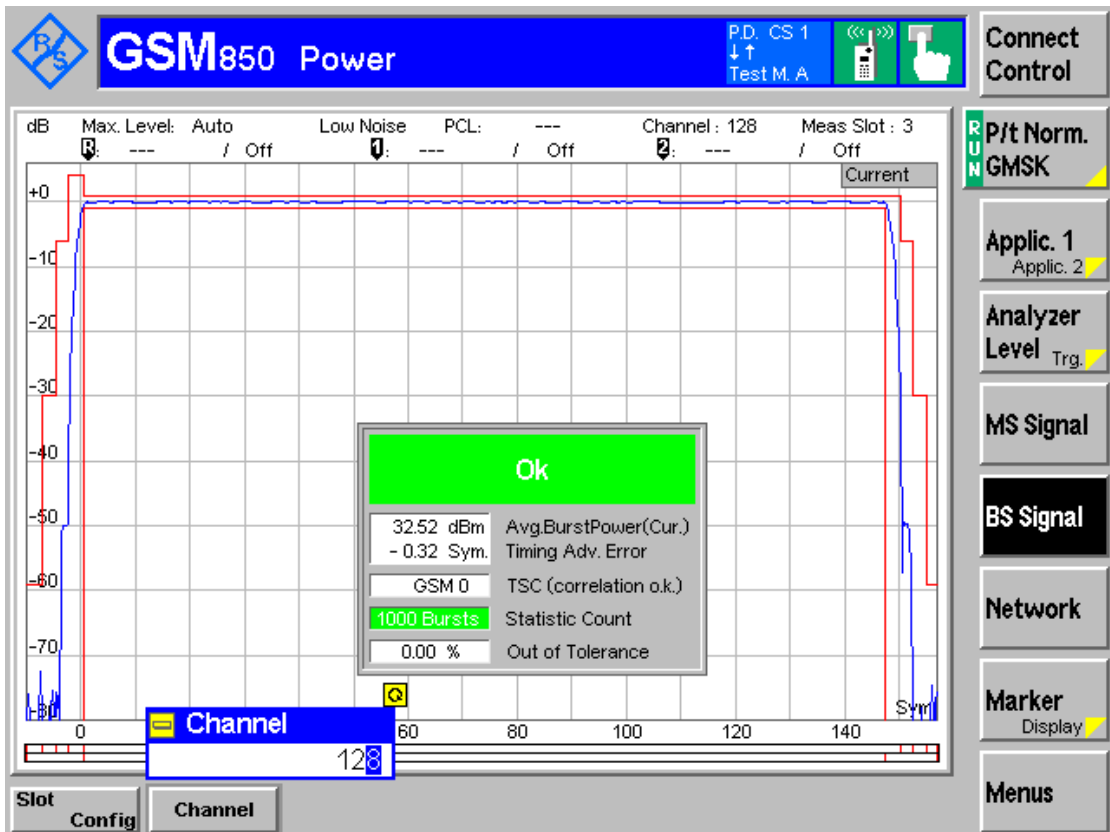

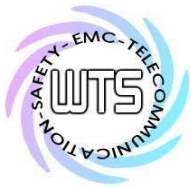

Report Number: W6M21308-13443-P-2224
 FCC ID: GX9MX

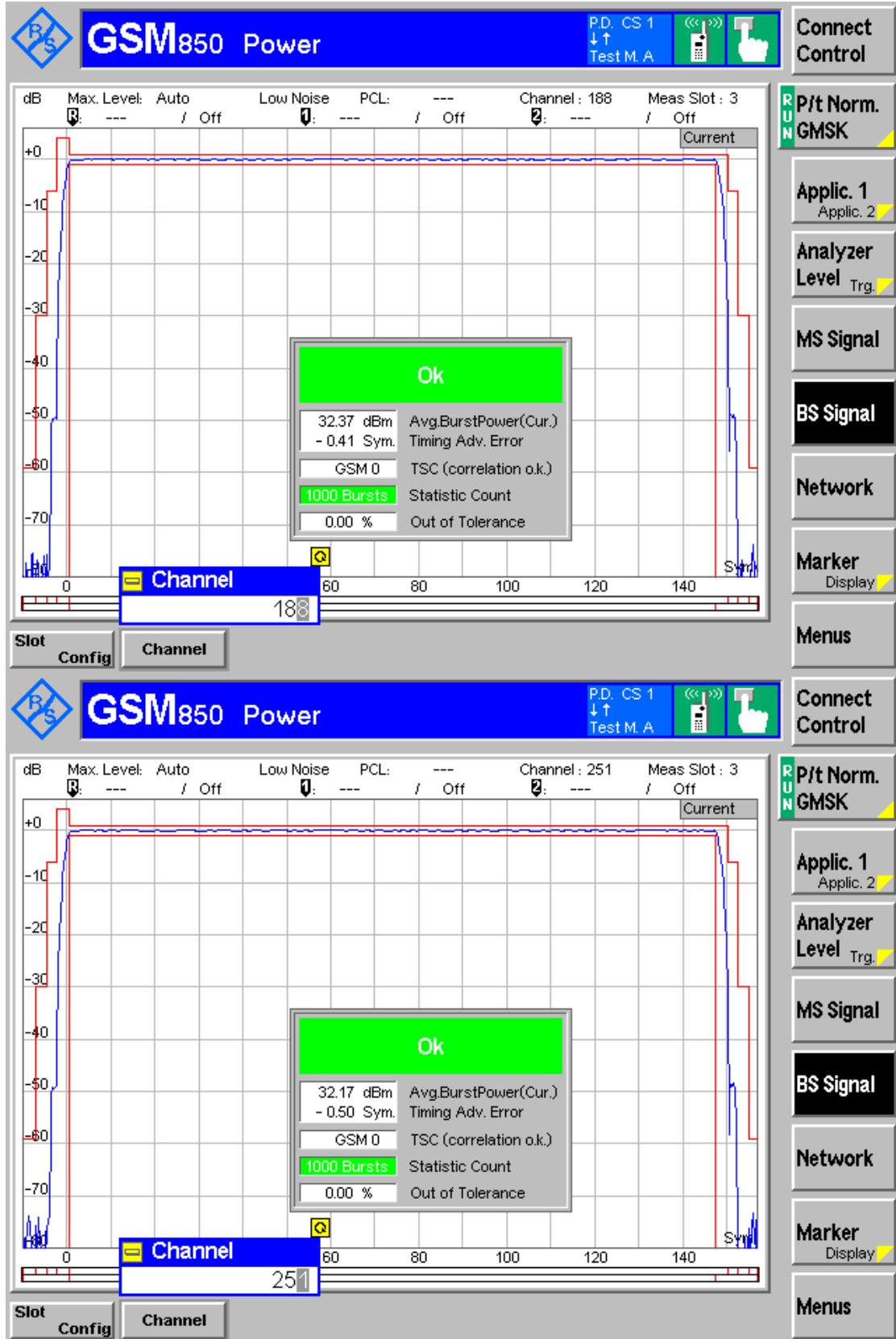

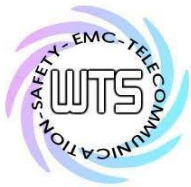

Report Number: W6M21308-13443-P-2224
FCC ID: GX9MX

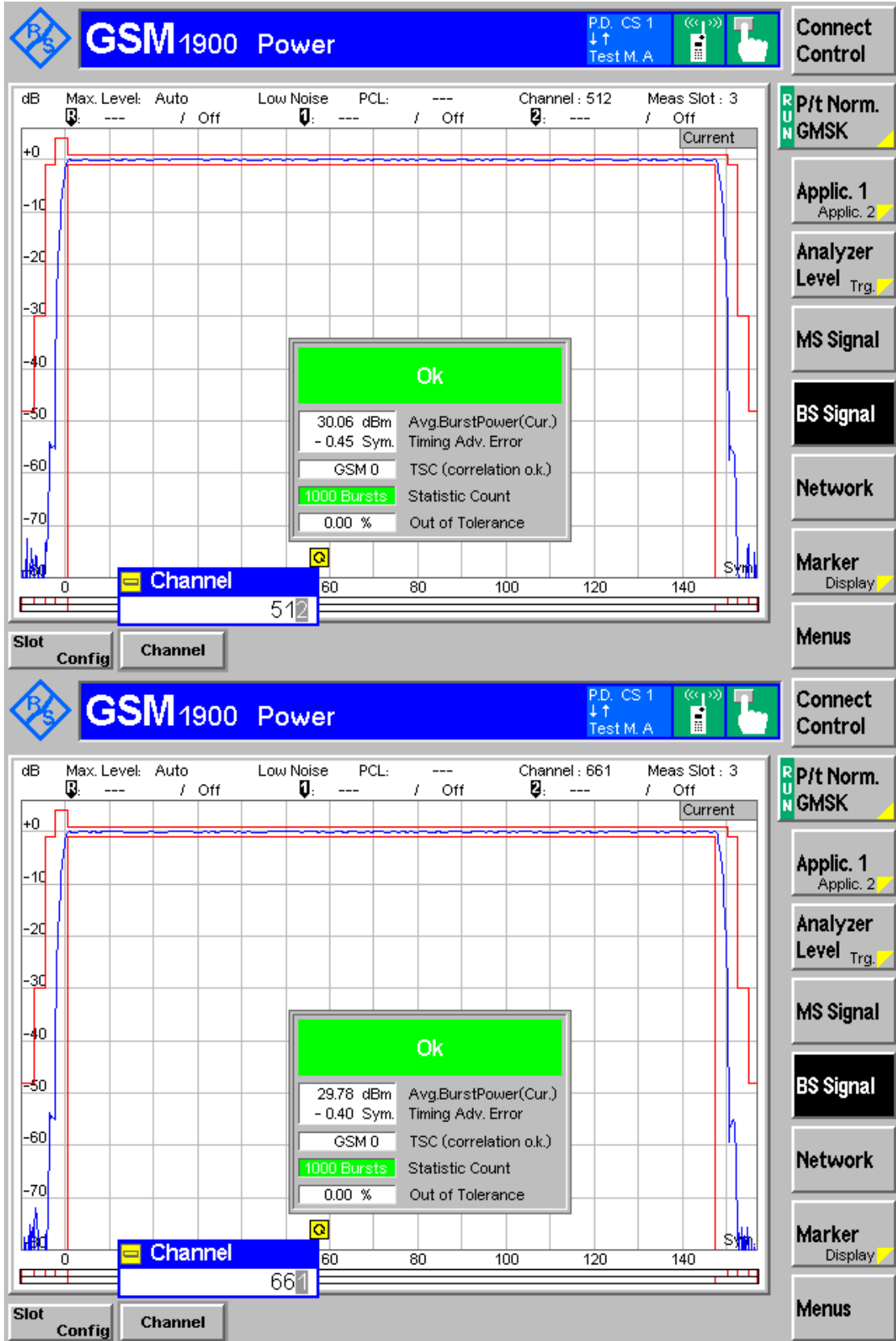

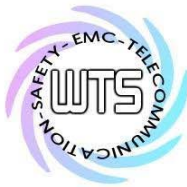

Report Number: W6M21308-13443-P-2224
 FCC ID: GX9MX

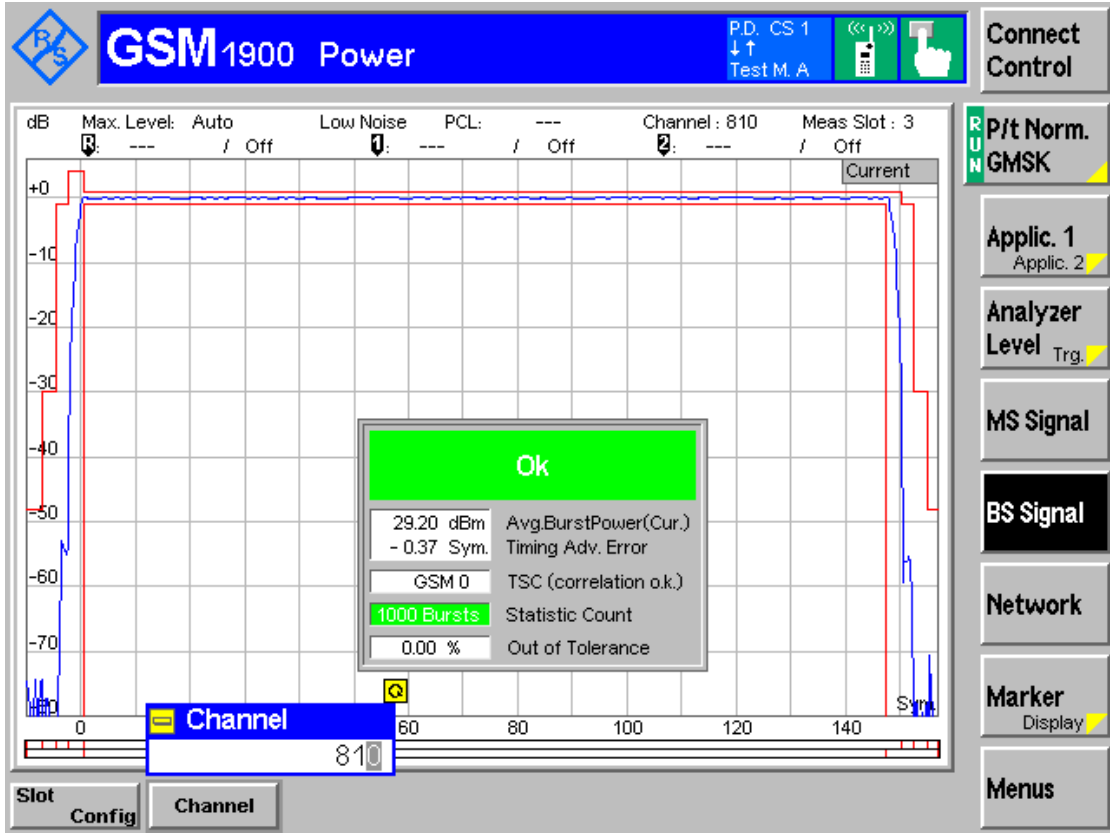

Band II
7 V

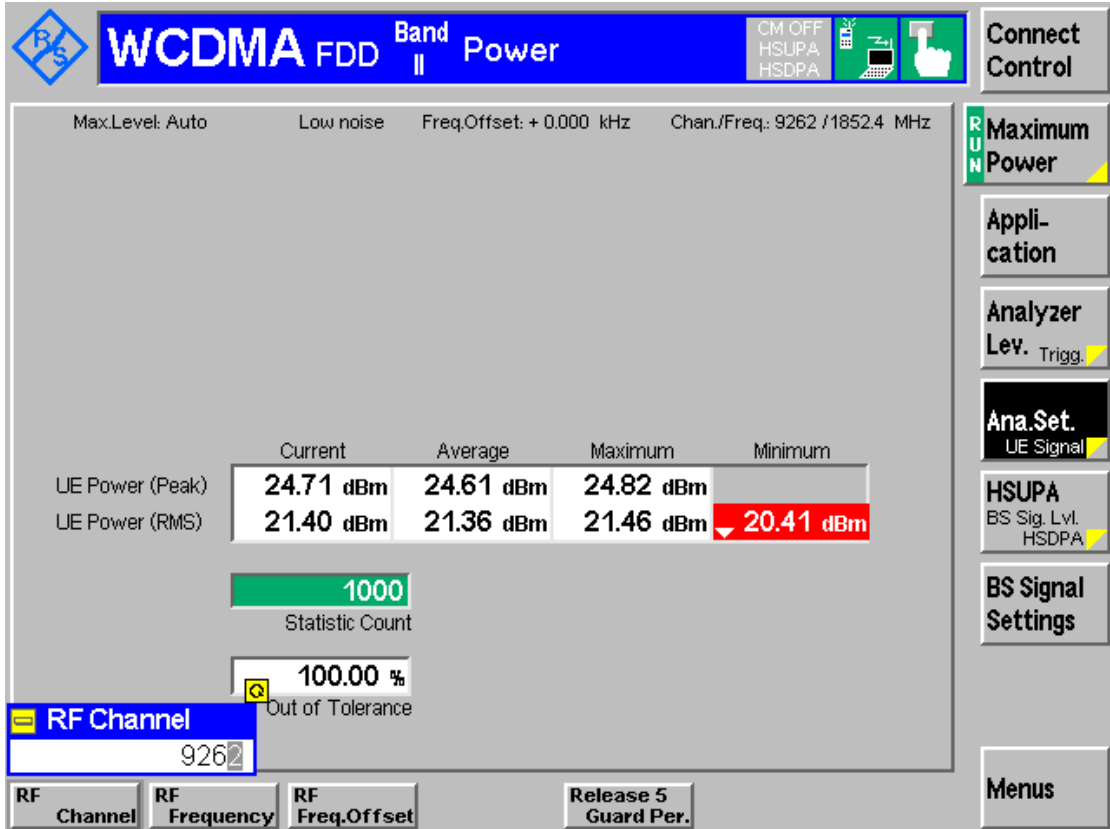

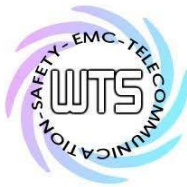

Report Number: W6M21308-13443-P-2224
 FCC ID: GX9MX

WCDMA FDD Band II Power
CM OFF HSUPA HSDPA

Max.Level: Auto Low noise Freq.Offset: + 0.000 kHz Chan./Freq.: 9400 /1880.0 MHz

	Current	Average	Maximum	Minimum
UE Power (Peak)	24.41 dBm	24.49 dBm	24.73 dBm	
UE Power (RMS)	21.26 dBm	21.18 dBm	21.29 dBm	20.20 dBm

1000
 Statistic Count

100.00 %
 Out of Tolerance

RF Channel: 9400

RF Channel
RF Frequency
RF Freq.Offset
Release 5 Guard Per.

WCDMA FDD Band II Power
CM OFF HSUPA HSDPA

Max.Level: Auto Low noise Freq.Offset: + 0.000 kHz Chan./Freq.: 9538 /1907.6 MHz

	Current	Average	Maximum	Minimum
UE Power (Peak)	23.50 dBm	24.30 dBm	24.55 dBm	
UE Power (RMS)	20.30 dBm	21.14 dBm	21.28 dBm	20.21 dBm

1000
 Statistic Count

100.00 %
 Out of Tolerance

RF Channel: 9538

RF Channel
RF Frequency
RF Freq.Offset
Release 5 Guard Per.

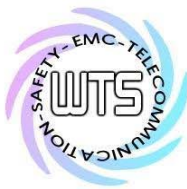

Report Number: W6M21308-13443-P-2224

FCC ID: GX9MX

7.92 V

WCDMA FDD Band II Power
CM OFF HSUPA HSDPA

Max.Level: Auto Low noise Freq.Offset: + 0.000 kHz Chan./Freq.: 9262 /1852.4 MHz

	Current	Average	Maximum	Minimum
UE Power (Peak)	24.60 dBm	24.61 dBm	24.82 dBm	
UE Power (RMS)	21.33 dBm	21.36 dBm	21.46 dBm	20.41 dBm

1000
 Statistic Count

100.00 %
 Out of Tolerance

RF Channel 9262

RF Channel
RF Frequency
RF Freq.Offset
Release 5 Guard Per.

WCDMA FDD Band II Power
CM OFF HSUPA HSDPA

Max.Level: Auto Low noise Freq.Offset: + 0.000 kHz Chan./Freq.: 9400 /1880.0 MHz

	Current	Average	Maximum	Minimum
UE Power (Peak)	24.46 dBm	24.50 dBm	24.77 dBm	
UE Power (RMS)	21.25 dBm	21.16 dBm	21.30 dBm	20.14 dBm

1000
 Statistic Count

100.00 %
 Out of Tolerance

RF Channel 9400

RF Channel
RF Frequency
RF Freq.Offset
Release 5 Guard Per.

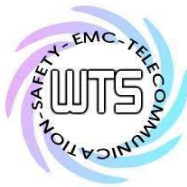

Report Number: W6M21308-13443-P-2224
 FCC ID: GX9MX

WCDMA FDD Band II Power CM OFF HSUPA HSDPA Connect Control

Max.Level: Auto Low noise Freq.Offset: + 0.000 kHz Chan./Freq.: 9538 /1907.6 MHz

	Current	Average	Maximum	Minimum
UE Power (Peak)	24.39 dBm	24.31 dBm	24.52 dBm	
UE Power (RMS)	21.22 dBm	21.15 dBm	21.26 dBm	20.26 dBm

1000
Statistic Count

100.00 %
Out of Tolerance

Power Modulation Spectrum Code Dom. Power Receiver Quality Menus

Band V
7 V

WCDMA FDD Band V Power CM OFF HSUPA HSDPA Connect Control

Max.Level: Auto Low noise Freq.Offset: + 0.000 kHz Chan./Freq.: 4132 /826.4 MHz

	Current	Average	Maximum	Minimum
UE Power (Peak)	25.86 dBm	25.78 dBm	26.05 dBm	
UE Power (RMS)	22.47 dBm	22.41 dBm	22.51 dBm	21.36 dBm

1000
Statistic Count

100.00 %
Out of Tolerance

RF Channel 4132

RF Channel RF Frequency RF Freq.Offset Release 5 Guard Per. Menus

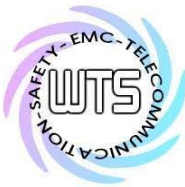

Report Number: W6M21308-13443-P-2224
 FCC ID: GX9MX

WCDMA FDD Band ν Power
CM OFF HSUPA HSDPA

Max.Level: Auto Low noise Freq.Offset: + 0.000 kHz Chan./Freq.: 4183 /836.6 MHz

	Current	Average	Maximum	Minimum
UE Power (Peak)	25.45 dBm	25.39 dBm	25.66 dBm	
UE Power (RMS)	22.34 dBm	22.23 dBm	22.35 dBm	21.31 dBm

1000
 Statistic Count

100.00 %
 Out of Tolerance

RF Channel 4183

RF Channel
RF Frequency
RF Freq.Offset
Release 5 Guard Per.

WCDMA FDD Band ν Power
CM OFF HSUPA HSDPA

Max.Level: Auto Low noise Freq.Offset: + 0.000 kHz Chan./Freq.: 4233 /846.6 MHz

	Current	Average	Maximum	Minimum
UE Power (Peak)	26.07 dBm	26.11 dBm	26.37 dBm	
UE Power (RMS)	22.92 dBm	22.87 dBm	22.99 dBm	21.82 dBm

1000
 Statistic Count

100.00 %
 Out of Tolerance

Power
Modulation
Spectrum
Code Dom. Power
Receiver Quality

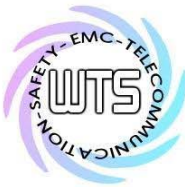

Worldwide Testing Services(Taiwan) Co., Ltd.

Report Number: W6M21308-13443-P-2224

FCC ID: GX9MX

7.92 V

WCDMA FDD Band **v** Power
CM OFF HSUPA HSDPA

Max.Level: Auto Low noise Freq.Offset: + 0.000 kHz Chan./Freq.: 4132 /826.4 MHz

	Current	Average	Maximum	Minimum
UE Power (Peak)	25.89 dBm	25.77 dBm	26.02 dBm	
UE Power (RMS)	22.45 dBm	22.39 dBm	22.50 dBm	21.34 dBm

1000
 Statistic Count

100.00 %
 Out of Tolerance

RF Channel
4132

RF Channel
RF Frequency
RF Freq.Offset
Release 5 Guard Per.

WCDMA FDD Band **v** Power
CM OFF HSUPA HSDPA

Max.Level: Auto Low noise Freq.Offset: + 0.000 kHz Chan./Freq.: 4183 /836.6 MHz

	Current	Average	Maximum	Minimum
UE Power (Peak)	25.55 dBm	25.40 dBm	25.69 dBm	
UE Power (RMS)	22.27 dBm	22.22 dBm	22.37 dBm	21.26 dBm

1000
 Statistic Count

100.00 %
 Out of Tolerance

RF Channel
4183

RF Channel
RF Frequency
RF Freq.Offset
Release 5 Guard Per.

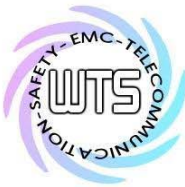

Report Number: W6M21308-13443-P-2224
 FCC ID: GX9MX

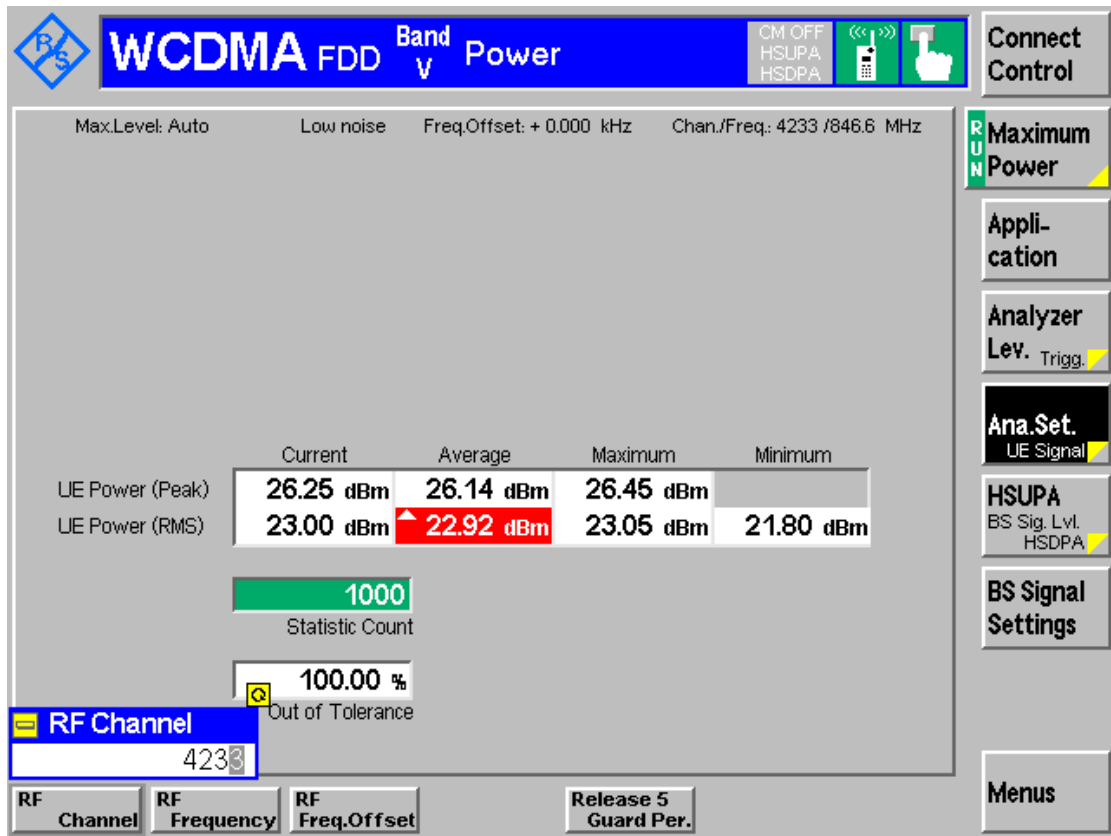

- Conducted Measurement
- Radiated Measurement

Band 850 MHz & 1900 MHz

7 V

Frequency (MHz)	ERP (dBm)	EIRP (dBm)	Limit (dBm)	Result
824.2671	28.42	30.57	38.45	Pass
836.2731	29.04	31.19	38.45	Pass
848.7328	28.03	30.18	38.45	Pass
1850.1350	29.93	32.08	33	Pass
1880.0610	29.75	31.90	33	Pass
1909.863	27.97	30.12	33	Pass

7.92 V

Frequency (MHz)	ERP (dBm)	EIRP (dBm)	Limit (dBm)	Result
824.1330	28.43	30.58	38.45	Pass
836.2671	29.07	31.22	38.45	Pass
848.7350	28.04	30.19	38.45	Pass
1850.129	29.68	31.83	33	Pass
1880.065	29.73	31.88	33	Pass
1909.861	27.80	29.95	33	Pass



Report Number: W6M21308-13443-P-2224
FCC ID: GX9MX

Band II & Band V

7 V

Frequency (MHz)	ERP (dBm)	EIRP (dBm)	Limit (dBm)	Result
1851.1220	23.14	25.29	33	Pass
1879.1730	20.68	22.83	33	Pass
1906.5630	18.53	20.68	33	Pass
825.6831	15.60	17.75	38.45	Pass
837.5168	16.00	18.15	38.45	Pass
845.5330	17.16	19.31	38.45	Pass

7.92 V

Frequency (MHz)	ERP (dBm)	EIRP (dBm)	Limit (dBm)	Result
1852.3850	23.35	25.50	33	Pass
1879.3840	20.60	22.75	33	Pass
1906.5330	18.47	20.62	33	Pass
826.5850	16.02	18.17	38.45	Pass
837.1261	15.91	18.06	38.45	Pass
845.4427	17.05	19.20	38.45	Pass

Note: ERP Value=EIRP-2.15

Test equipment: ETSTW-RE 004, ETSTW-RE 030, ETSTW-RE 111, ETSTW-GSM 02

Note: Please refer to appendix for plot data.

Report Number: W6M21308-13443-P-2224

FCC ID: GX9MX

4. Modulation Characteristics

4.1 Test procedure

- A curve or equivalent data showing the frequency response of the audio modulating circuit over a range of 100 to 5000 Hz shall be submitted.
The audio signal generator is connected to the audio input of the EUT with its full rating. The modulation response is measured at certain modulation frequencies, related to 1000Hz reference signal. Tests are performed for positive and negative modulation.

- Equipment which employs modulation Limiting: A curve or family of curves showing the percentage of modulation versus the modulation input voltage shall be supplied. The audio signal generator is connected to the audio input of the EUT with its full rating. The modulation limiting is measured at certain modulation frequencies from 100Hz to 15kHz.

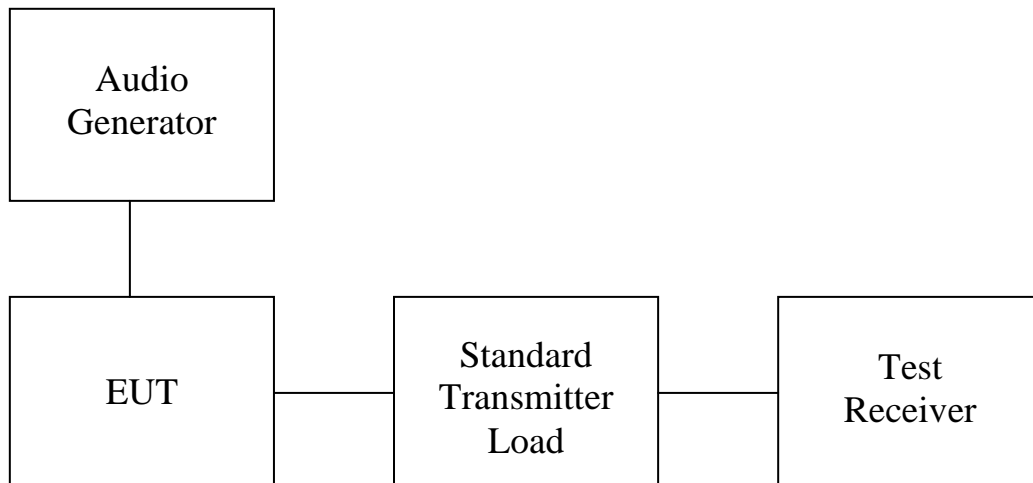

4.2 Test Results

For digital modulation employed, this test item is not applicable.

Report Number: W6M21308-13443-P-2224

FCC ID: GX9MX

5. Occupied Bandwidth

The occupied bandwidth, that is the frequency bandwidth such that, below its lower and above its upper frequency limits, the mean powers radiated are each equal to 0.5 percent of the total mean power. Near the carrier an Emission Mask is defined by the standard.

5.1 Test procedure

The RF output of the transceiver was connected as the following figure.

Occupied Bandwidth was measured with a occupied bandwidth function of the analyzer at 99% power was occupied. Then set the spectrum analyzer to cover the upper and lower band edges to measure emission mask.

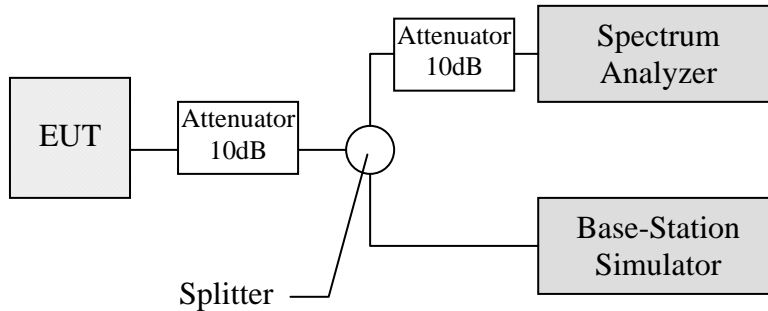

5.2 Test Results

Occupied Channel Bandwidth

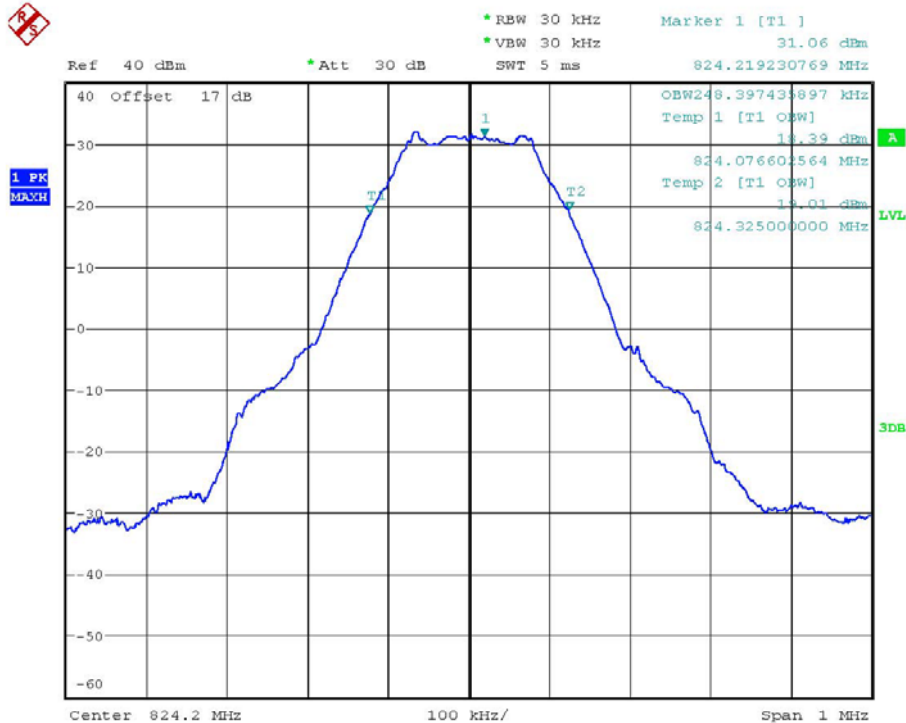

OCCUPIED BANDWIDTH GSM850 CH128

Date: 22.AUG.2013 17:26:13



Report Number: W6M21308-13443-P-2224
 FCC ID: GX9MX

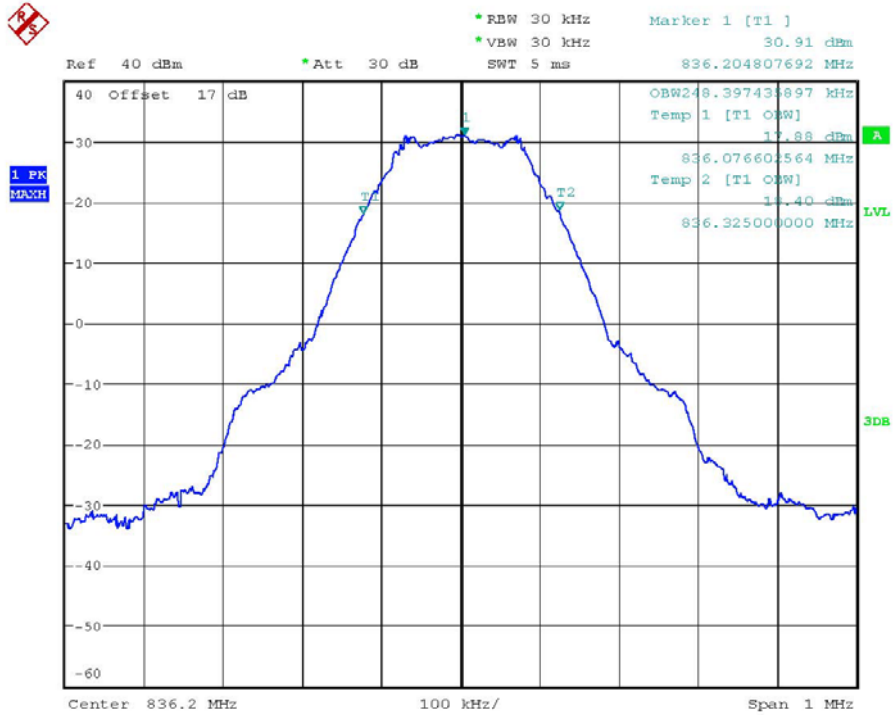

OCCUPIED BANDWIDTH GSM850 CH188
 Date: 22.AUG.2013 17:27:02

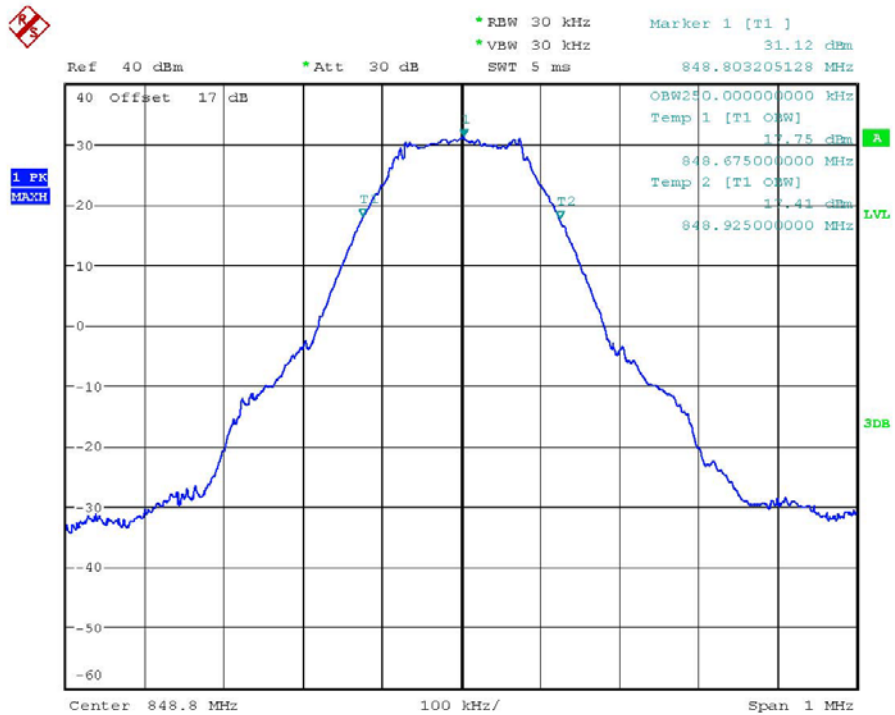

OCCUPIED BANDWIDTH GSM850 CH251
 Date: 22.AUG.2013 17:27:49



Report Number: W6M21308-13443-P-2224
 FCC ID: GX9MX

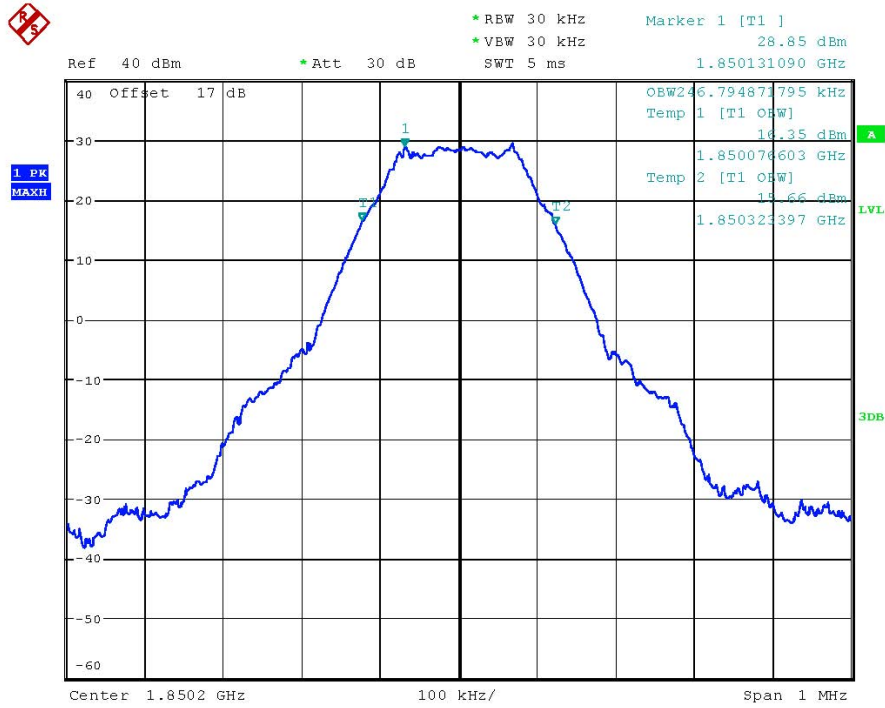

OCCUPIED BANDWIDTH PCS1900 CH512
 Date: 22.AUG.2013 17:10:27

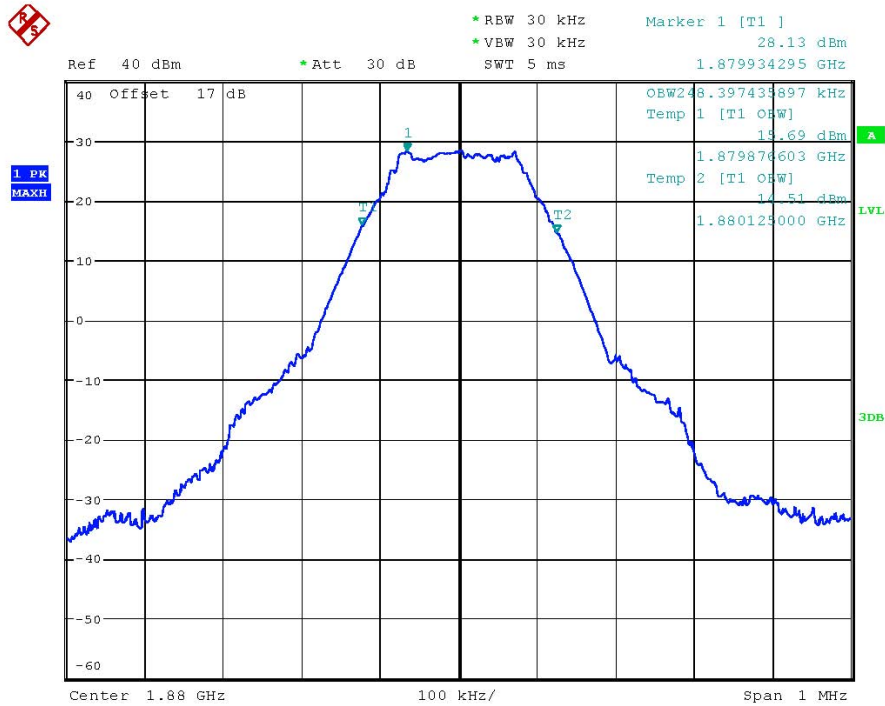

OCCUPIED BANDWIDTH PCS1900 CH661
 Date: 22.AUG.2013 17:09:49



Report Number: W6M21308-13443-P-2224
 FCC ID: GX9MX

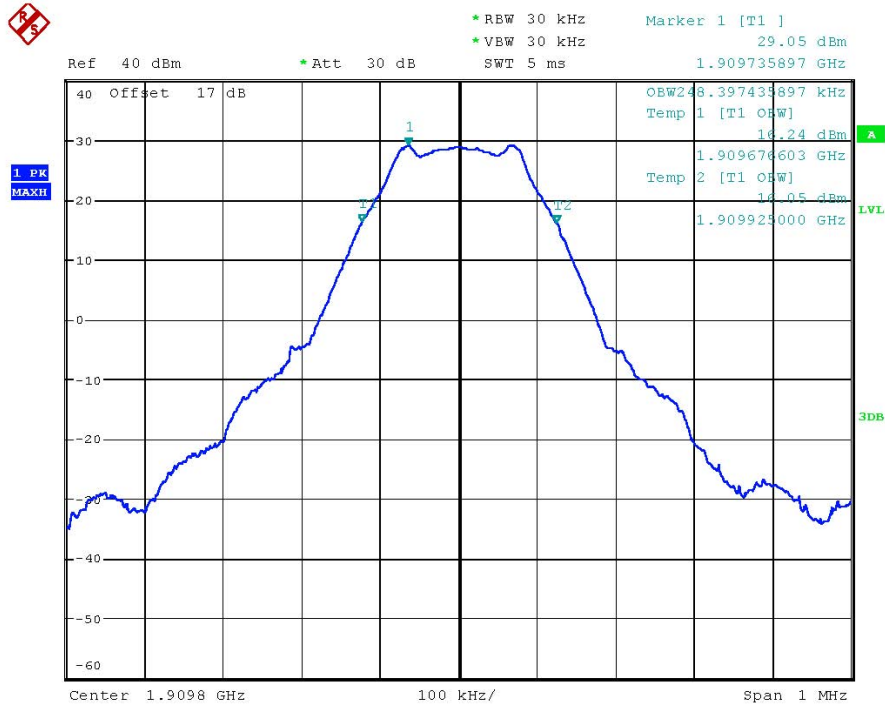

OCCUPIED BANDWIDTH PCS1900 CH810
 Date: 22.AUG.2013 17:08:47

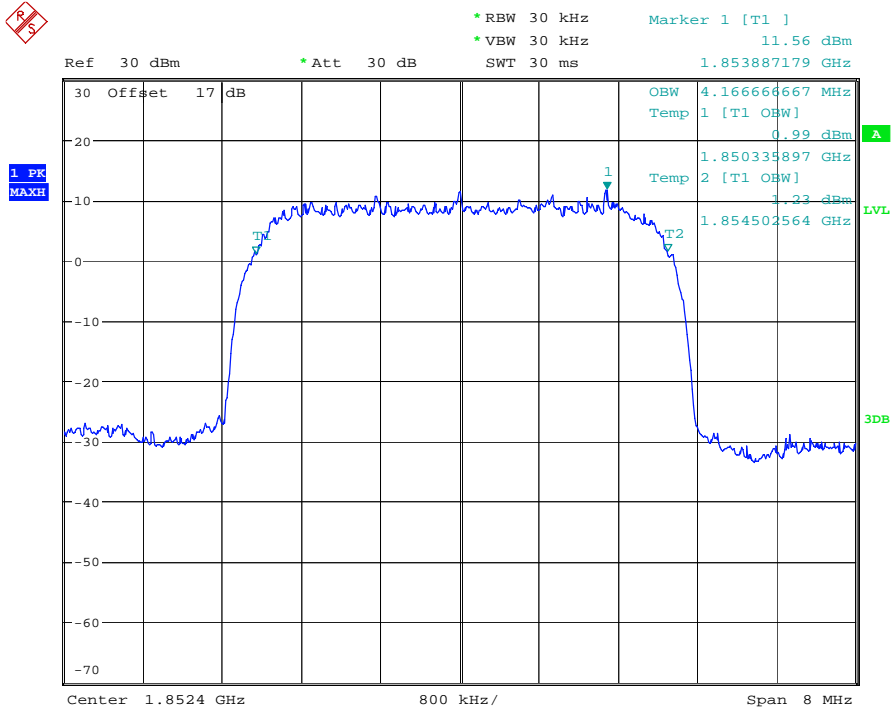

OCCUPIED BANDWIDTH WCDMA BAND II CH9262
 Date: 22.AUG.2013 17:30:35

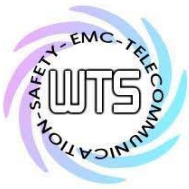

Report Number: W6M21308-13443-P-2224
 FCC ID: GX9MX

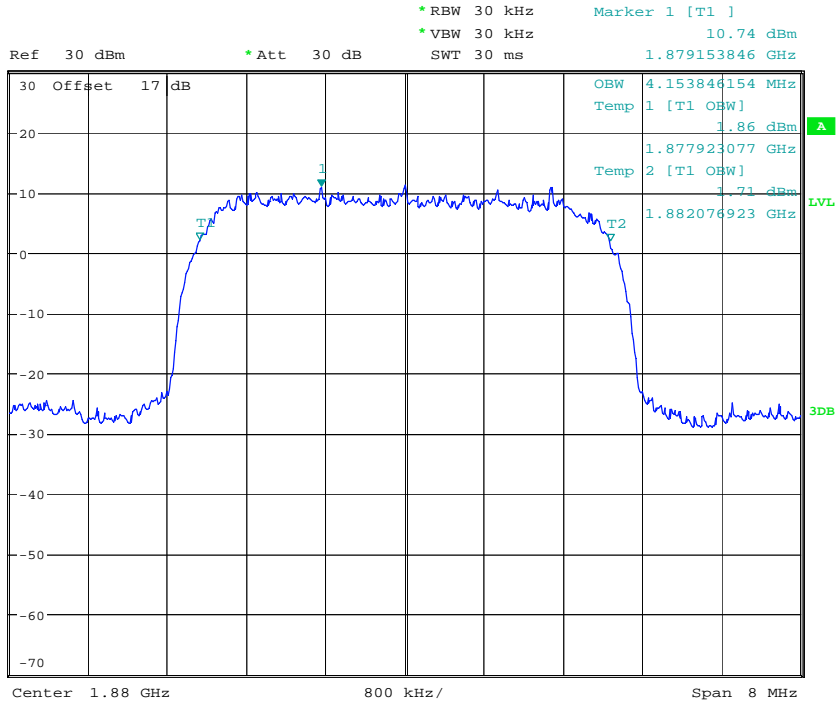

OCCUPIED BANDWIDTH WCDMA BAND II CH9400

Date: 22.AUG.2013 17:44:02

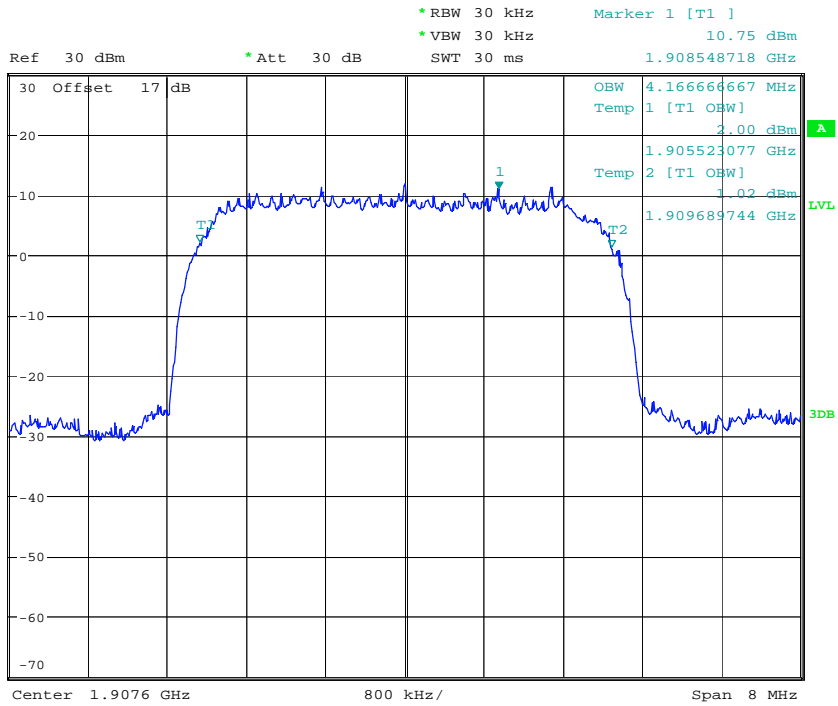

OCCUPIED BANDWIDTH WCDMA BAND II CH9538

Date: 22.AUG.2013 17:45:32

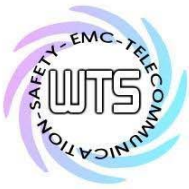

Report Number: W6M21308-13443-P-2224
FCC ID: GX9MX

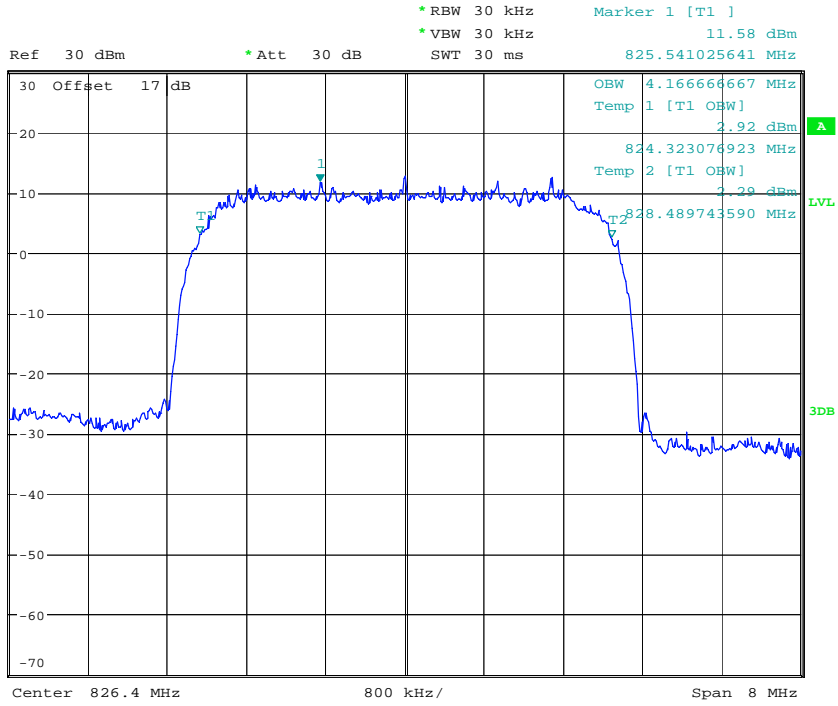

OCCUPIED BANDWIDTH WCDMA BAND V CH4132

Date: 22.AUG.2013 18:00:10

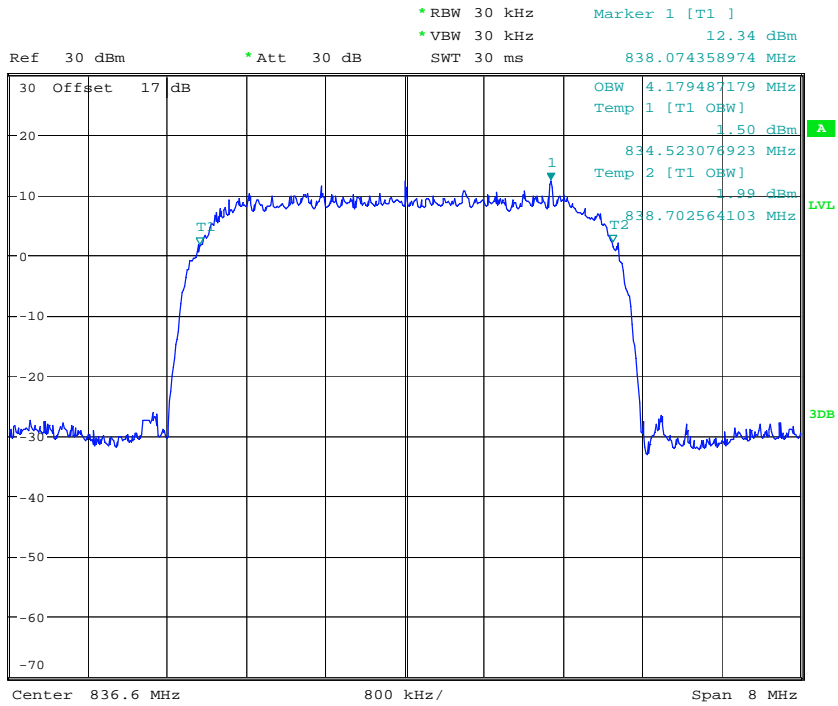

OCCUPIED BANDWIDTH WCDMA BAND V CH4183

Date: 22.AUG.2013 18:00:50



Report Number: W6M21308-13443-P-2224
 FCC ID: GX9MX

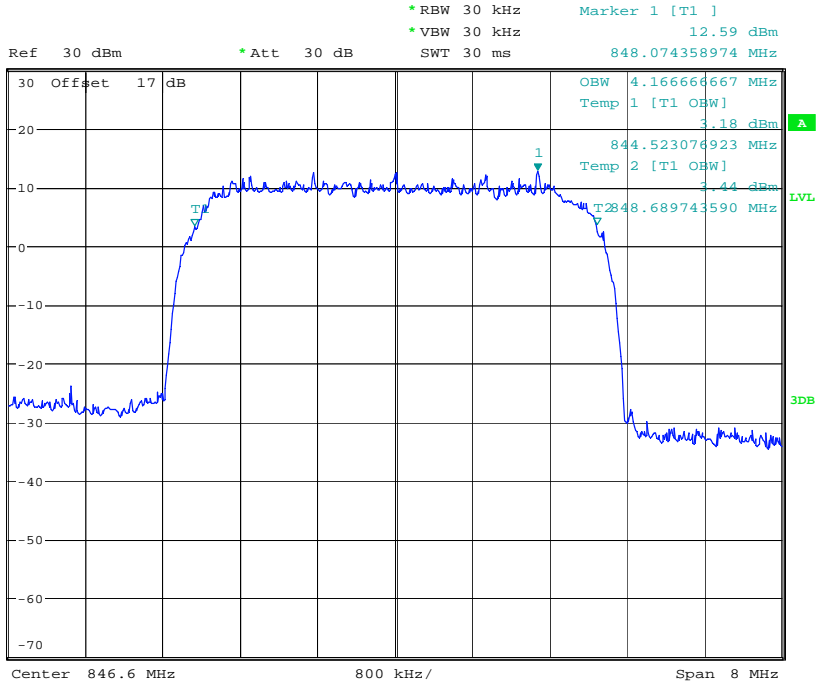

OCCUPIED BANDWIDTH WCDMA BAND V CH4233
 Date: 22.AUG.2013 17:58:17

26dB Channel Bandwidth

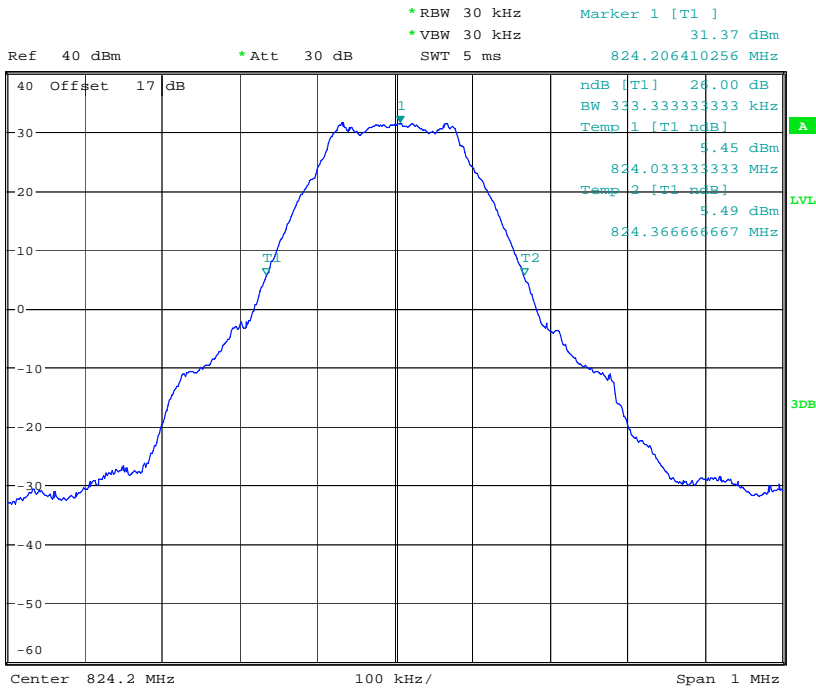

26DB BANDWIDTH GSM850 CH128
 Date: 22.AUG.2013 16:40:28

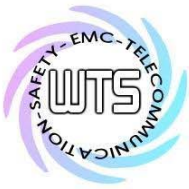

Report Number: W6M21308-13443-P-2224
 FCC ID: GX9MX

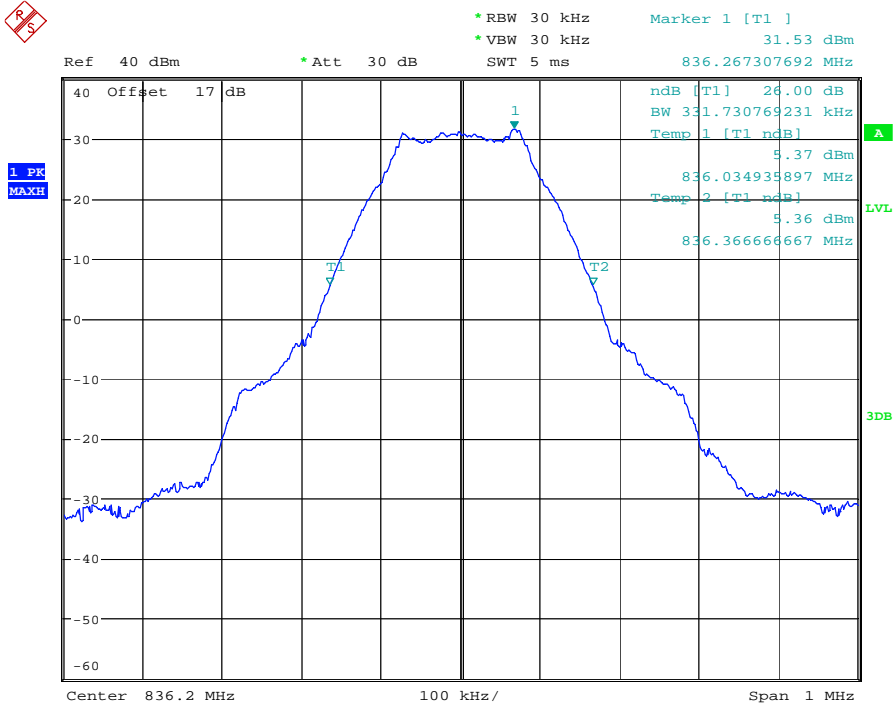

26DB BANDWIDTH GSM850 CH188
 Date: 22.AUG.2013 16:41:27

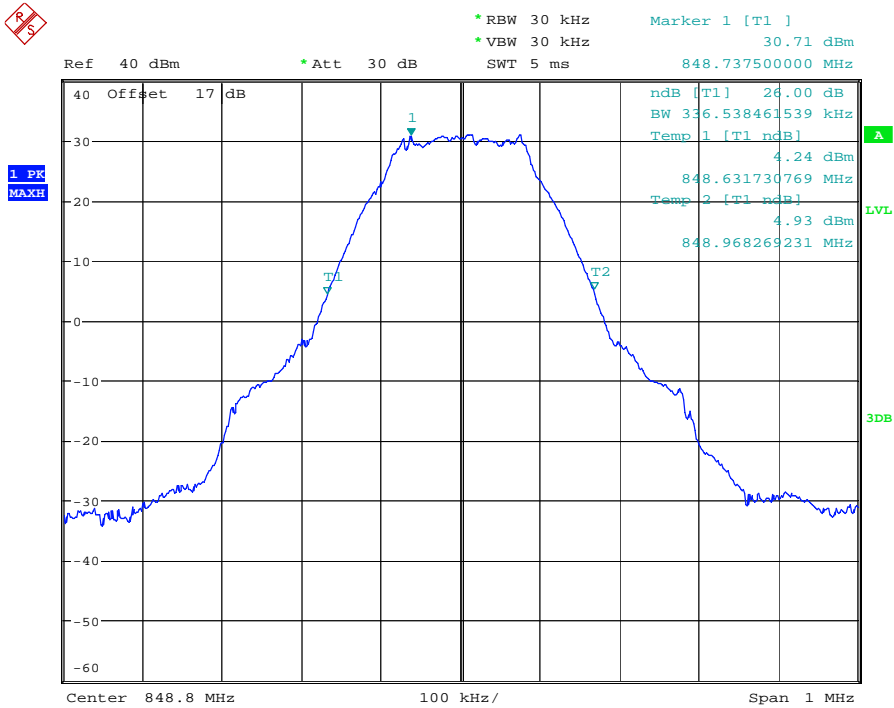

26DB BANDWIDTH GSM850 CH251
 Date: 22.AUG.2013 16:42:20



Worldwide Testing Services(Taiwan) Co., Ltd.

Report Number: W6M21308-13443-P-2224
 FCC ID: GX9MX

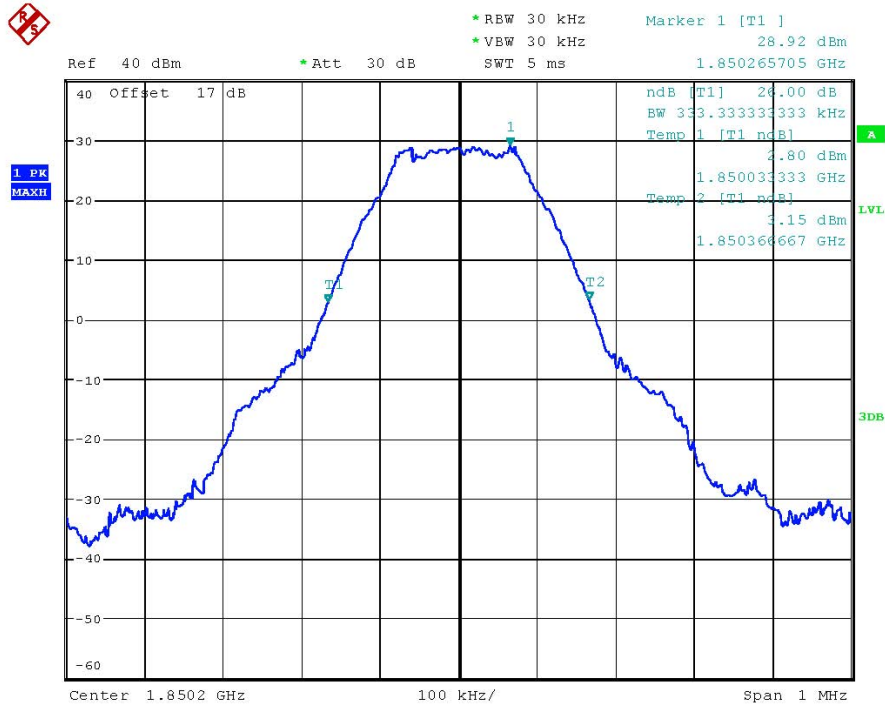

26DB BANDWIDTH PCS1900 CH512
 Date: 22.AUG.2013 16:46:04

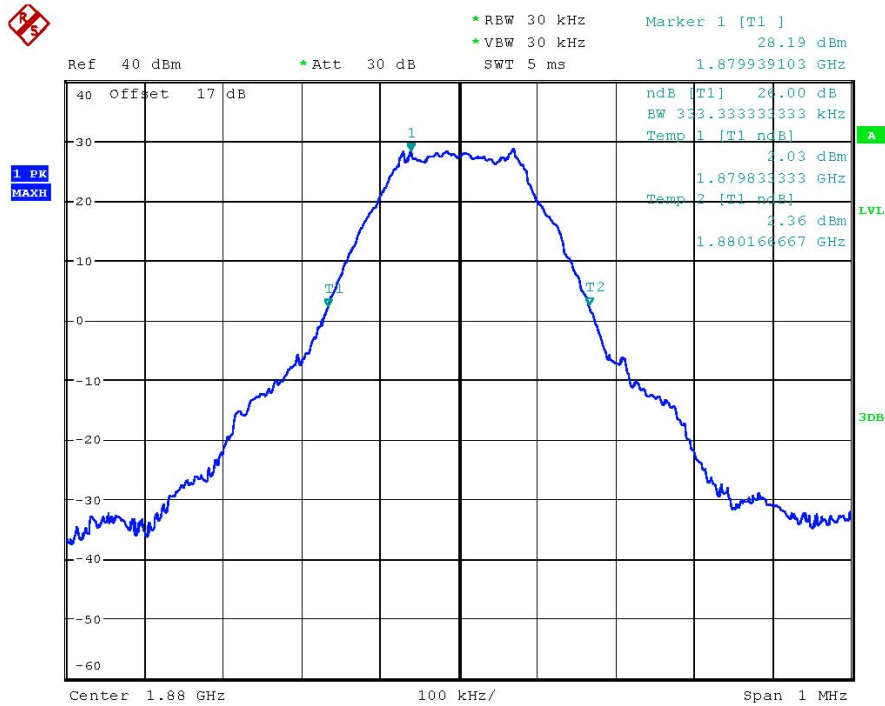

26DB BANDWIDTH PCS1900 CH661
 Date: 22.AUG.2013 16:47:05



Worldwide Testing Services(Taiwan) Co., Ltd.

Report Number: W6M21308-13443-P-2224
 FCC ID: GX9MX

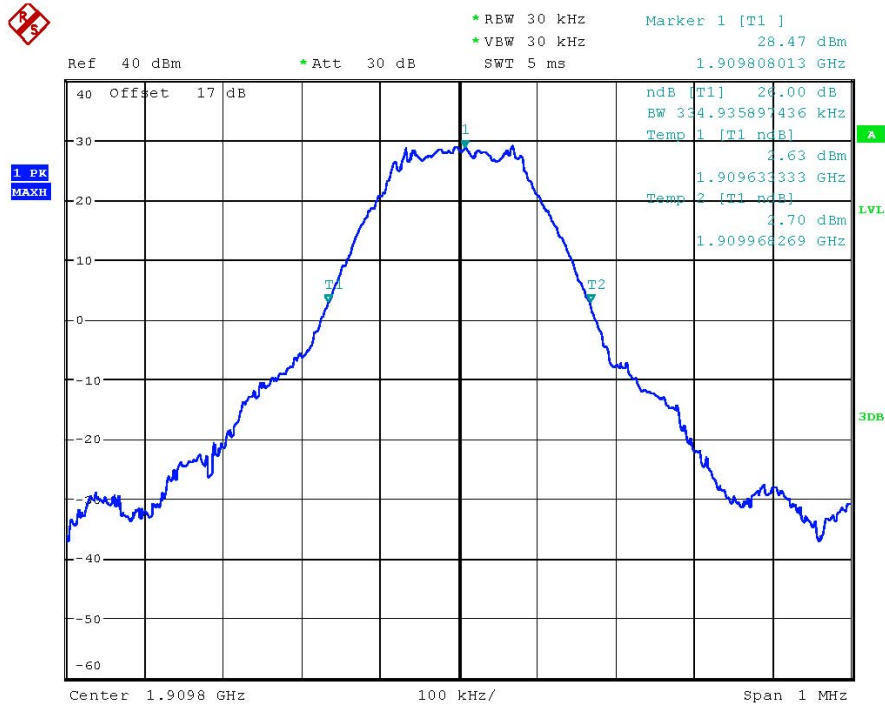

26DB BANDWIDTH PCS1900 CH810
 Date: 22.AUG.2013 16:47:57

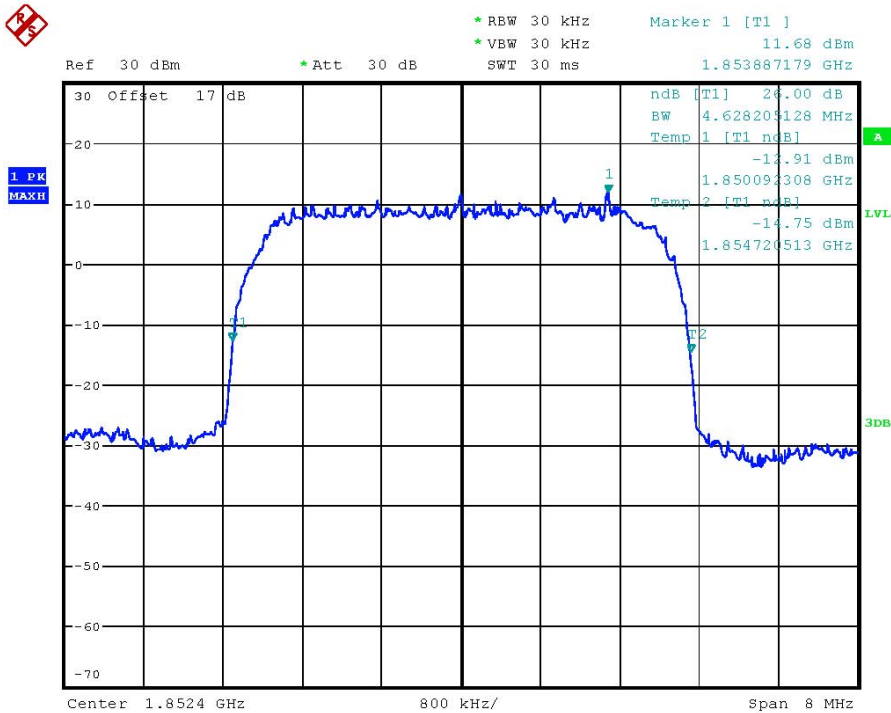

26DB BANDWIDTH WCDMA BAND II CH9262
 Date: 22.AUG.2013 16:32:51



Report Number: W6M21308-13443-P-2224
 FCC ID: GX9MX

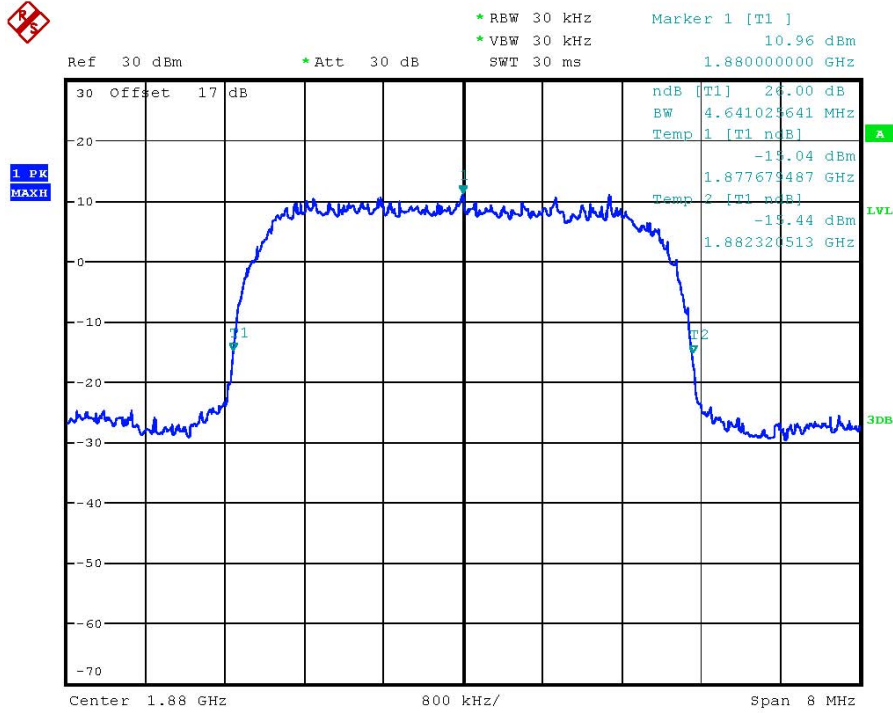

26DB BANDWIDTH WCDMA BAND II CH9400
 Date: 22.AUG.2013 16:33:42

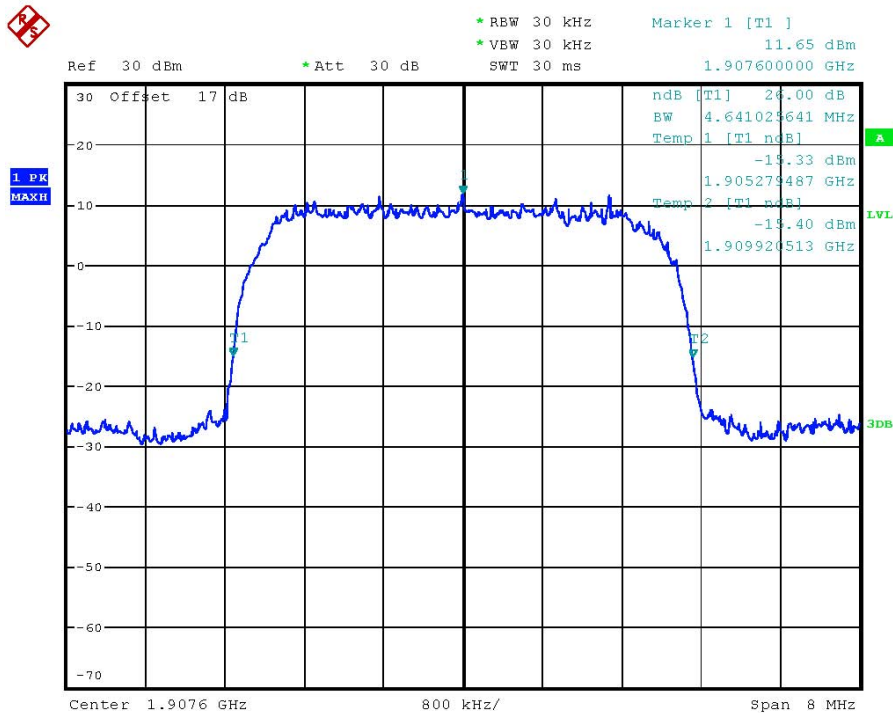

26DB BANDWIDTH WCDMA BAND II CH9538
 Date: 22.AUG.2013 16:34:35

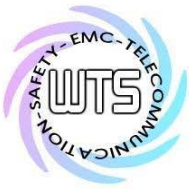

Worldwide Testing Services(Taiwan) Co., Ltd.

Report Number: W6M21308-13443-P-2224
 FCC ID: GX9MX

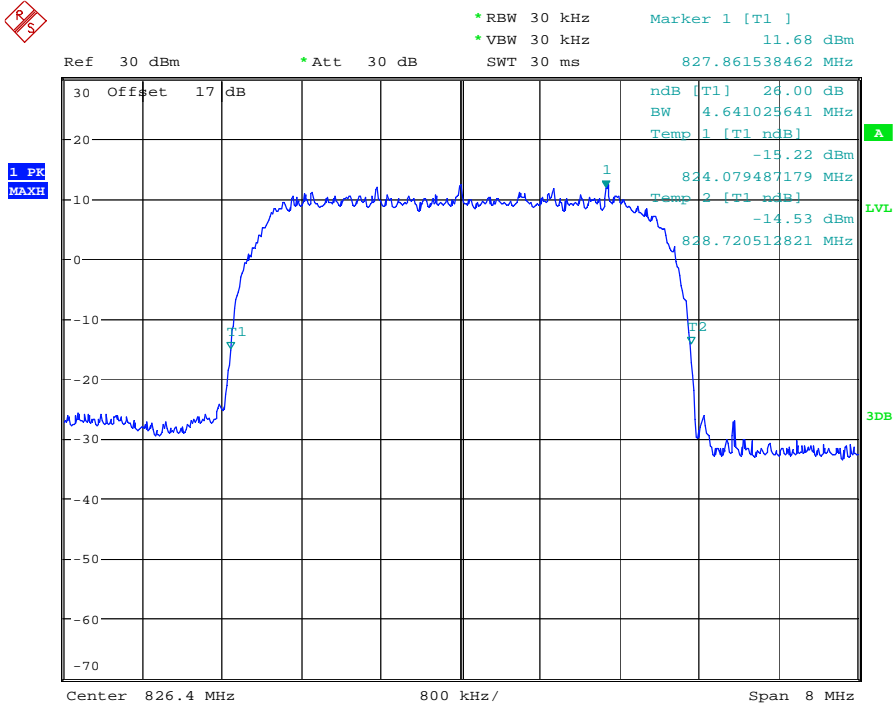

26DB BANDWIDTH WCDMA BAND V CH4132

Date: 22.AUG.2013 16:30:50

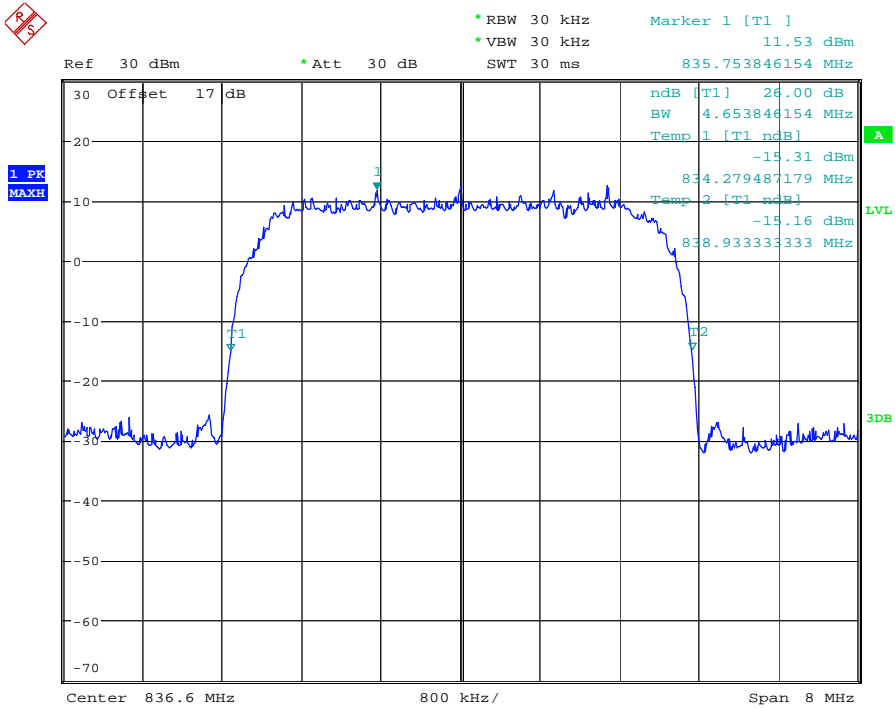

26DB BANDWIDTH WCDMA BAND V CH4183

Date: 22.AUG.2013 16:29:54

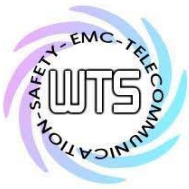

Report Number: W6M21308-13443-P-2224
FCC ID: GX9MX

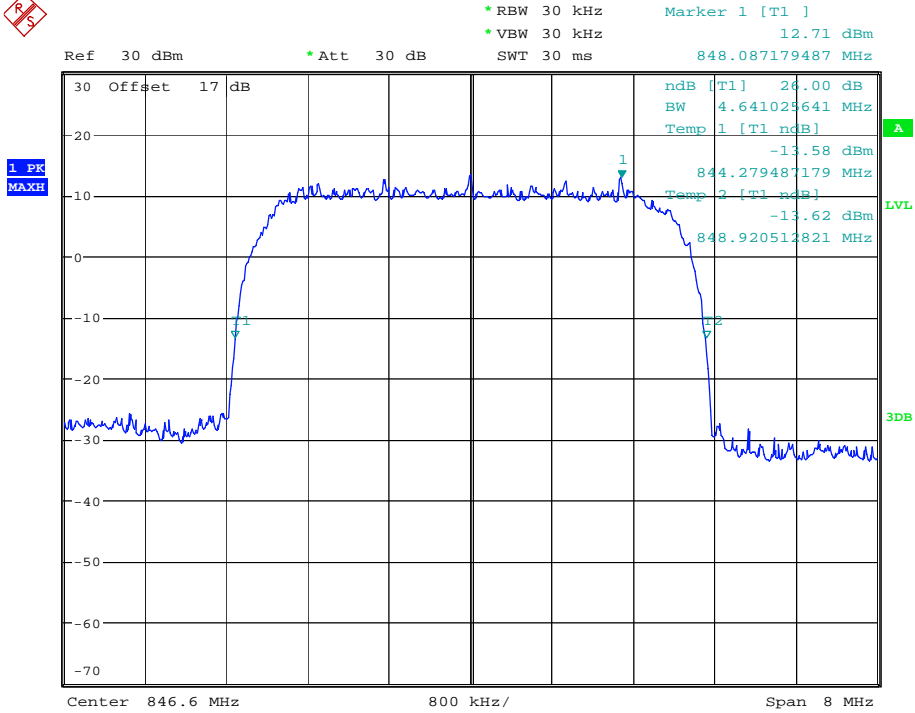

26DB BANDWIDTH WCDMA BAND V CH4233
Date: 22.AUG.2013 16:28:52

Test equipment: ETSTW-RE 055, ETSTW-GSM 02

Report Number: W6M21308-13443-P-2224

FCC ID: GX9MX

6. Spurious Emissions at Antenna Terminals

6.1 Test procedure

This transmitter output was connected to a calibrated coaxial attenuator, the other end of which was connected to a spectrum analyzer via a three-port splitter. Please refer to the following figure. Transmitter output was derived with the spectrum analyzer in dBm.

The Spurious Emissions at Antenna Terminals was measured by the spectrum analyzer with a suitable notch filter and/or Band-pass filter.

Tests were performed with an unmodulated carrier at three frequencies (low, middle and high channels) and on all power levels , which can be set-up on the transmitters.

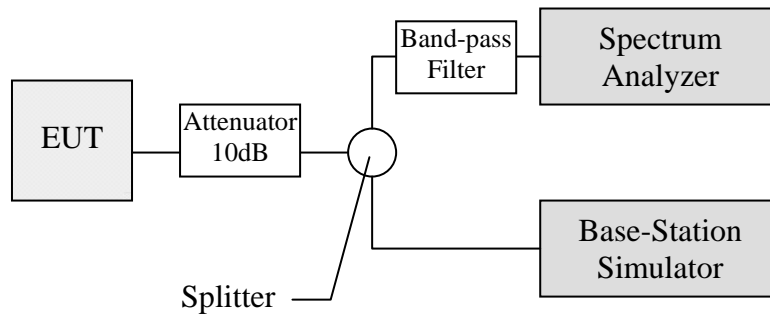

6.2 Test Results

CH128

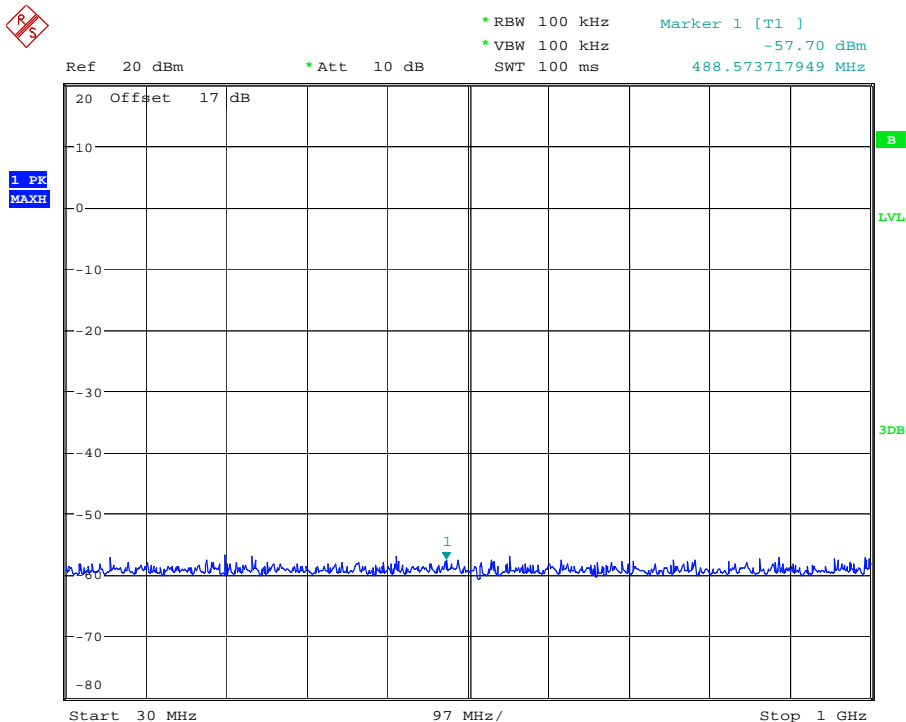

CONDUCTED SPURIOUS EMISSION GSM850 CH128

Date: 22.AUG.2013 22:14:55

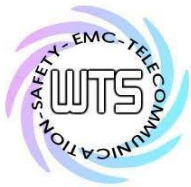

Report Number: W6M21308-13443-P-2224
FCC ID: GX9MX

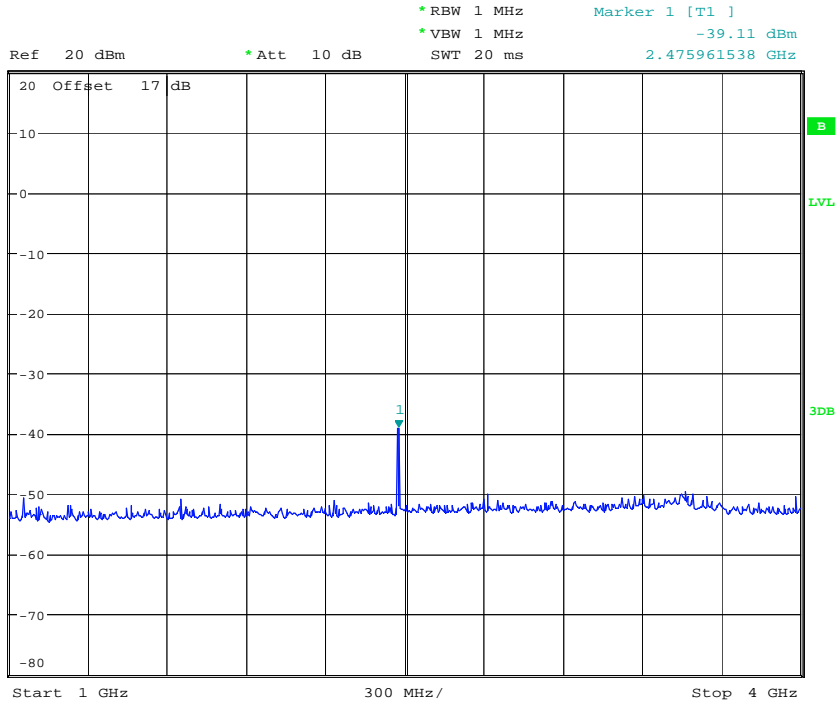

CONDUCTED SPURIOUS EMISSION GSM850 CH128

Date: 22.AUG.2013 22:16:54

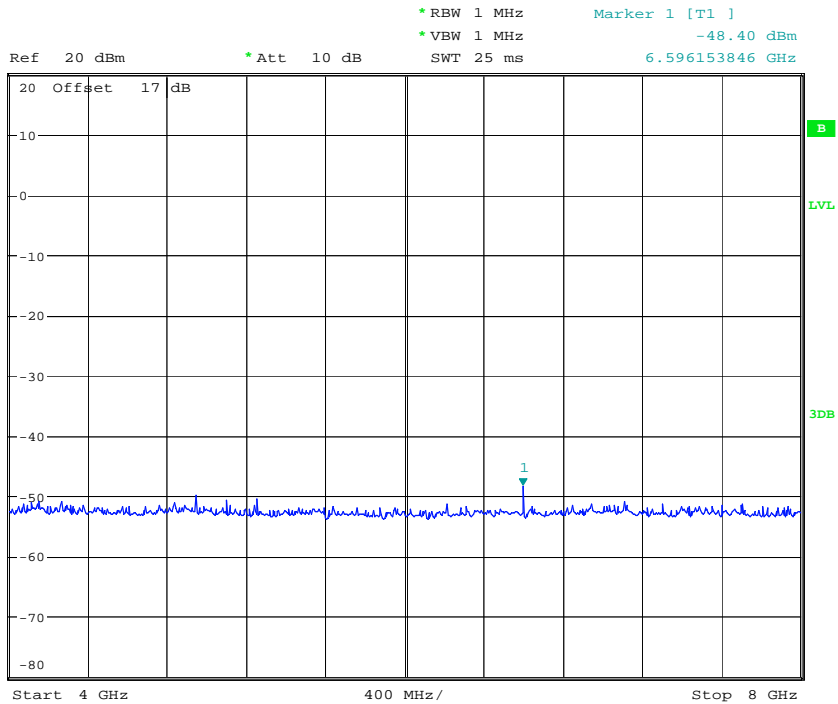

CONDUCTED SPURIOUS EMISSION GSM850 CH128

Date: 22.AUG.2013 22:19:40

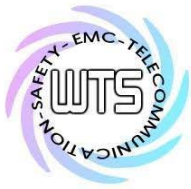

Report Number: W6M21308-13443-P-2224
FCC ID: GX9MX

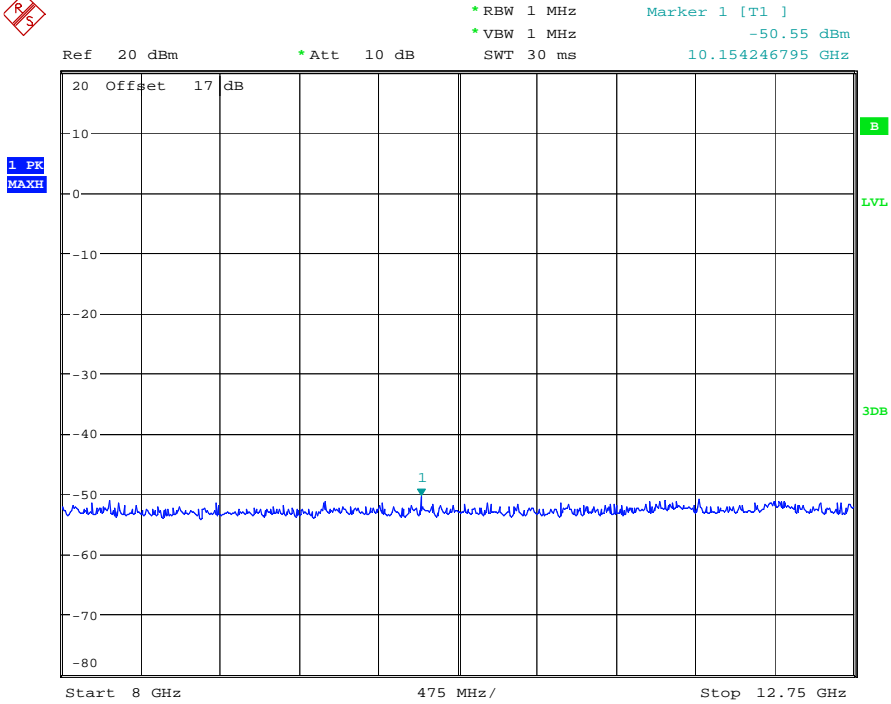

CONDUCTED SPURIOUS EMISSION GSM850 CH128

Date: 22.AUG.2013 22:21:19

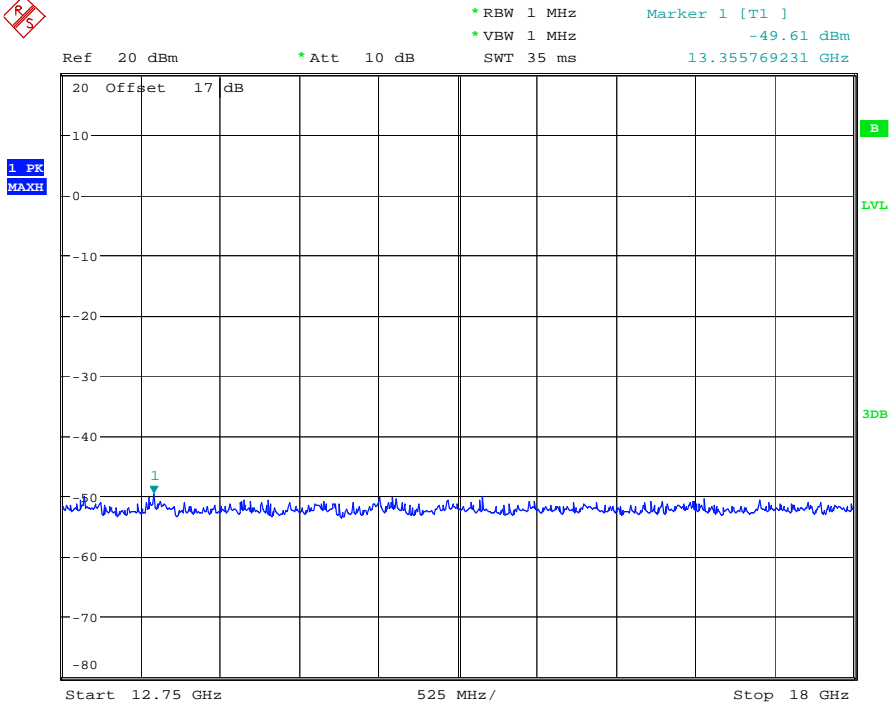

CONDUCTED SPURIOUS EMISSION GSM850 CH128

Date: 22.AUG.2013 22:22:18



Report Number: W6M21308-13443-P-2224
FCC ID: GX9MX



*RBW 1 MHz Marker 1 [T1]
*VBW 1 MHz -47.21 dBm
SWT 50 ms 26.472756410 GHz

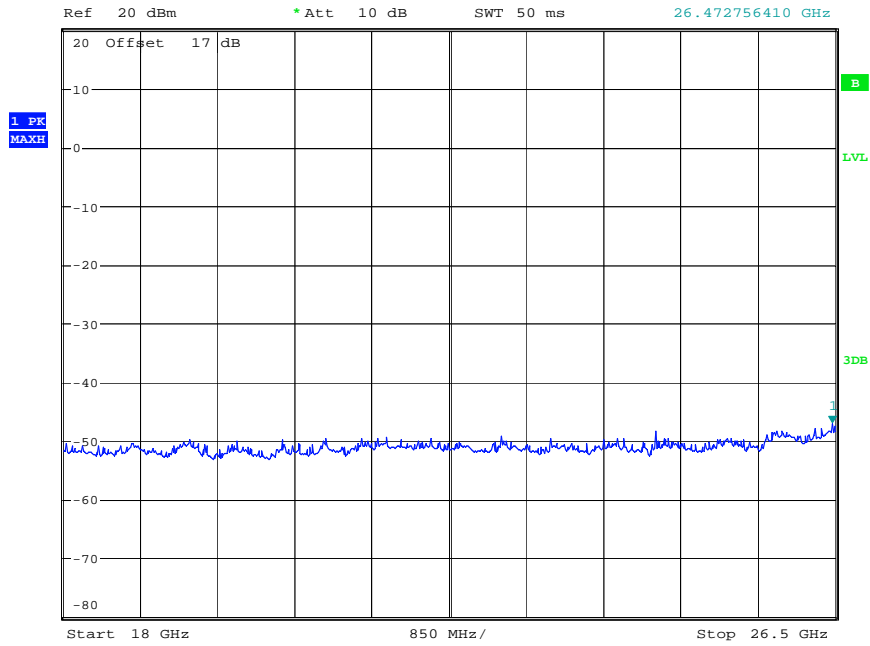

CONDUCTED SPURIOUS EMISSION GSM850 CH128
Date: 22.AUG.2013 22:23:58

CH188



*RBW 100 kHz Marker 1 [T1]
*VBW 100 kHz -57.33 dBm
SWT 100 ms 281.826923077 MHz

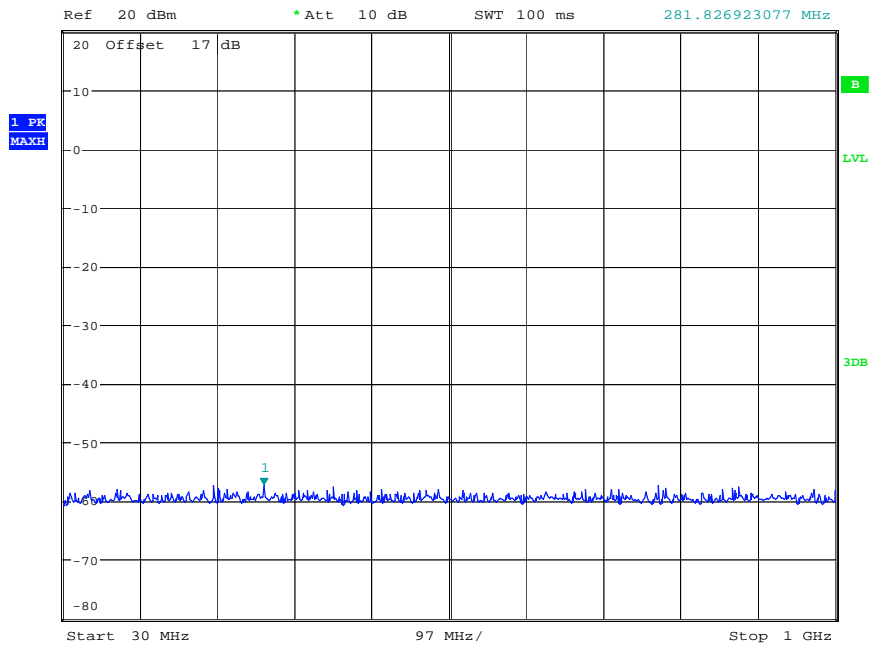

CONDUCTED SPURIOUS EMISSION GSM850 CH188
Date: 22.AUG.2013 22:15:20

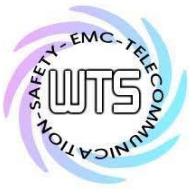

Report Number: W6M21308-13443-P-2224
FCC ID: GX9MX

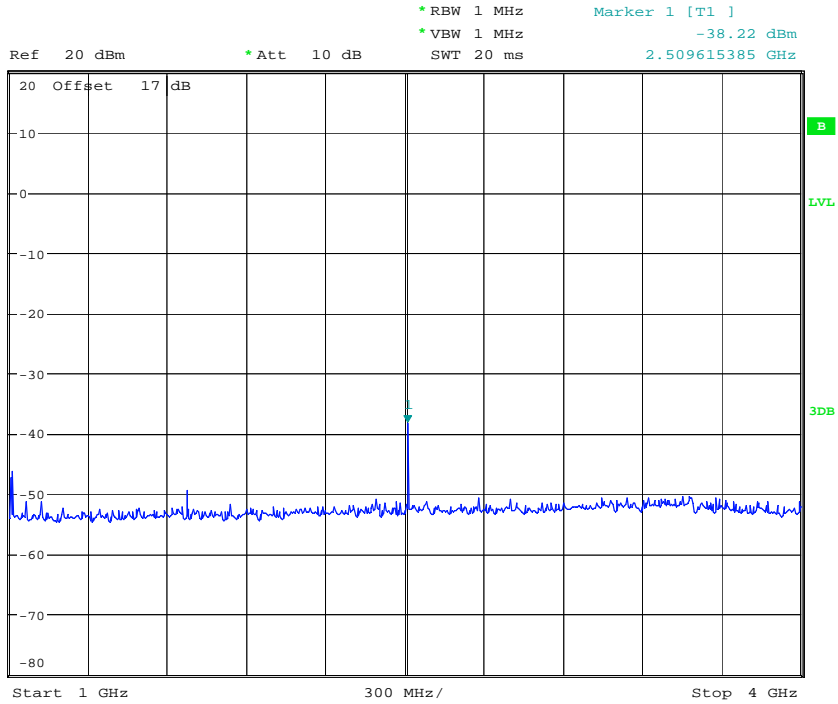

CONDUCTED SPURIOUS EMISSION GSM850 CH188

Date: 22.AUG.2013 22:17:22

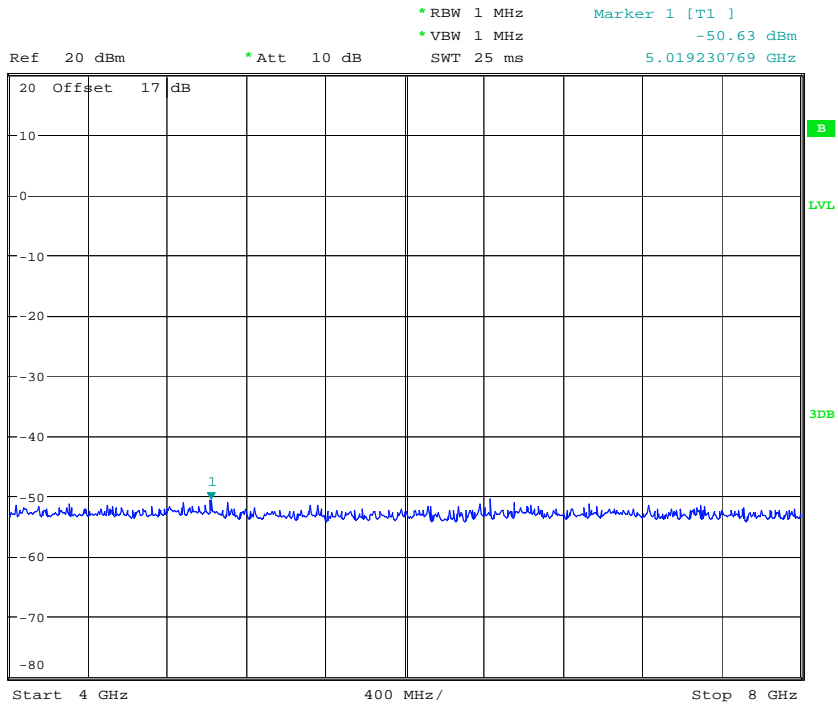

CONDUCTED SPURIOUS EMISSION GSM850 CH188

Date: 22.AUG.2013 22:20:01

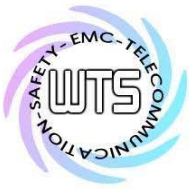

Report Number: W6M21308-13443-P-2224
FCC ID: GX9MX

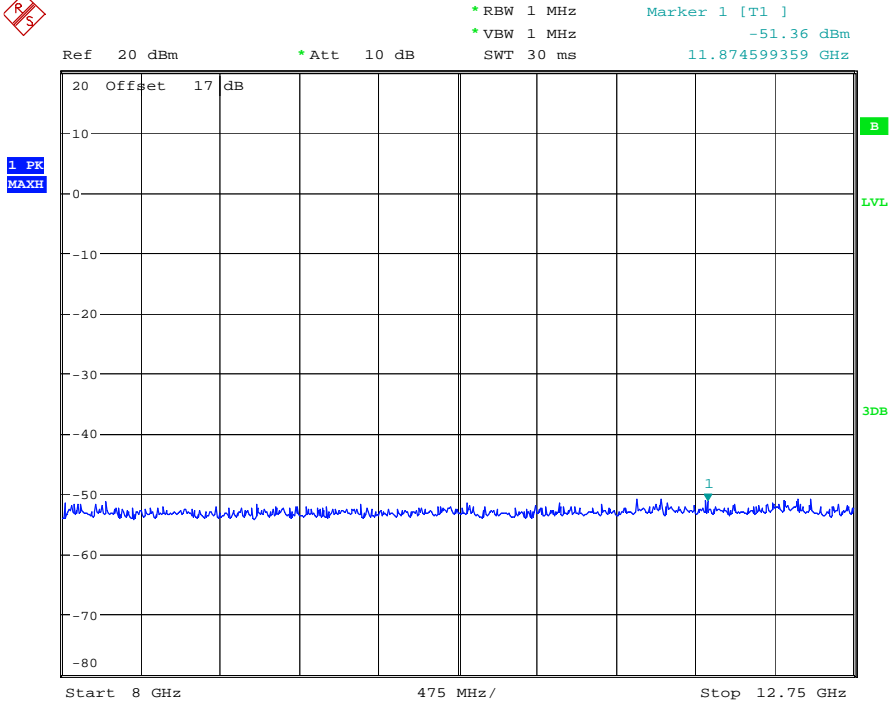

CONDUCTED SPURIOUS EMISSION GSM850 CH188

Date: 22.AUG.2013 22:21:02

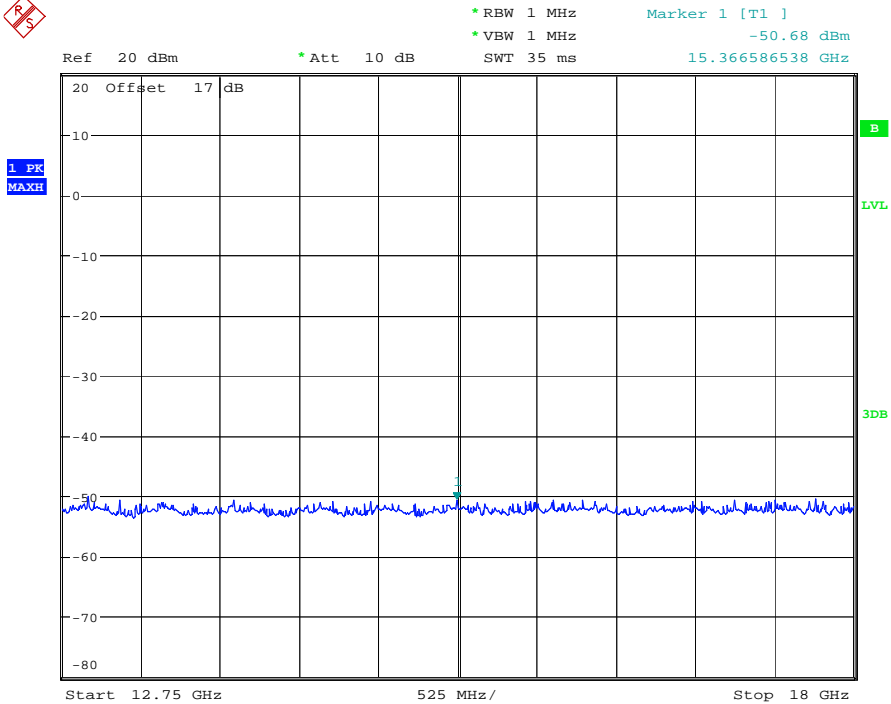

CONDUCTED SPURIOUS EMISSION GSM850 CH188

Date: 22.AUG.2013 22:22:34

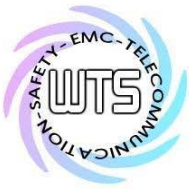

Report Number: W6M21308-13443-P-2224
FCC ID: GX9MX



* RBW 1 MHz Marker 1 [T1]
* VBW 1 MHz -48.03 dBm
SWT 50 ms 26.445512821 GHz

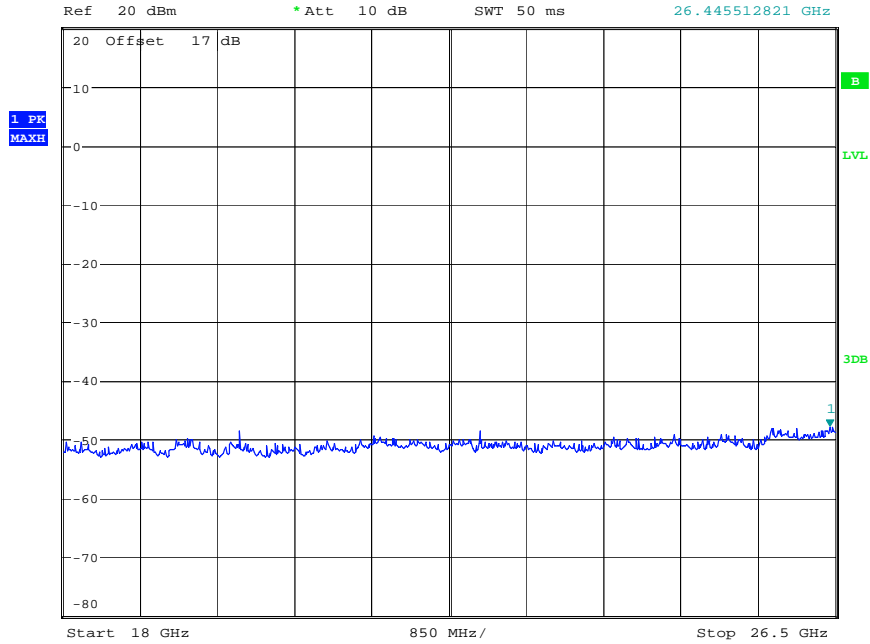

CONDUCTED SPURIOUS EMISSION GSM850 CH188
Date: 22.AUG.2013 22:23:42

CH251



* RBW 100 kHz Marker 1 [T1]
* VBW 100 kHz -56.44 dBm
SWT 100 ms 737.291666667 MHz

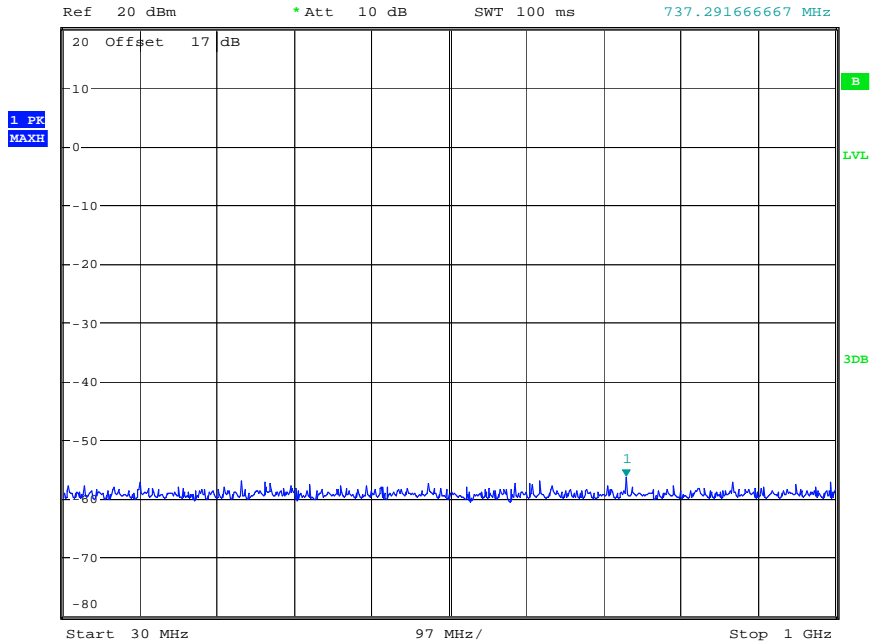

CONDUCTED SPURIOUS EMISSION GSM850 CH251
Date: 22.AUG.2013 22:15:45

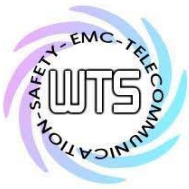

Report Number: W6M21308-13443-P-2224
FCC ID: GX9MX

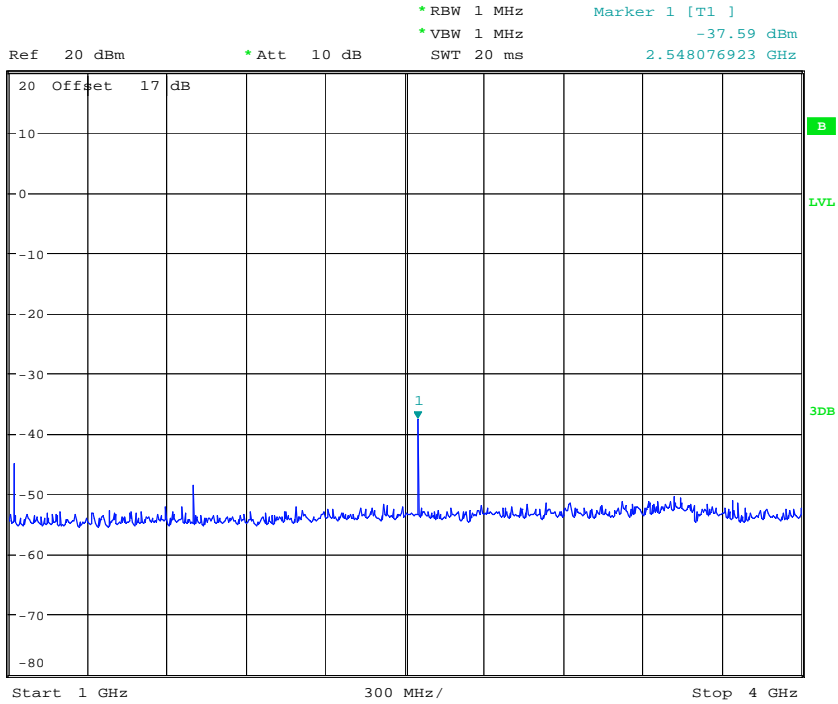

CONDUCTED SPURIOUS EMISSION GSM850 CH251

Date: 22.AUG.2013 22:18:00

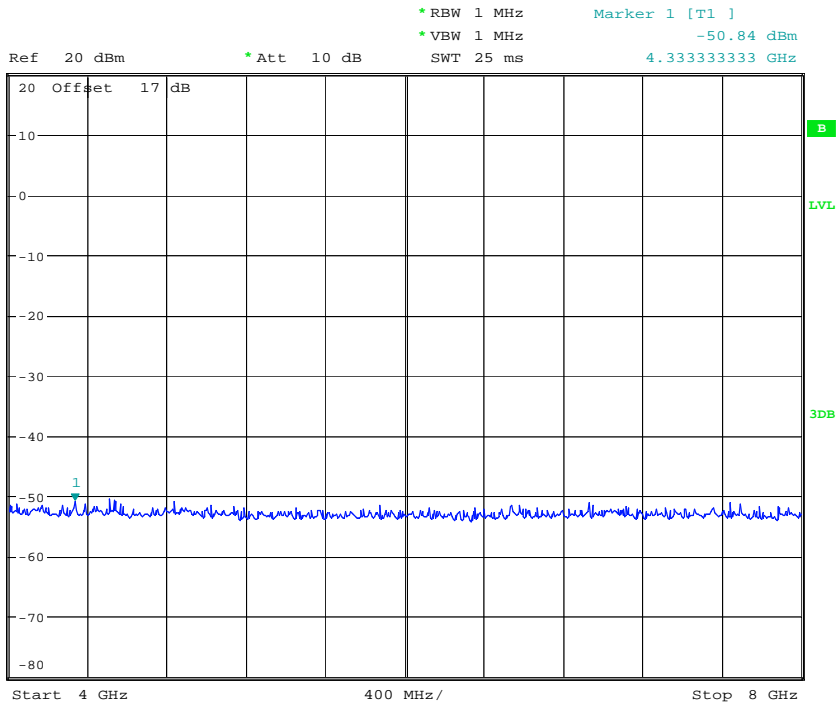

CONDUCTED SPURIOUS EMISSION GSM850 CH251

Date: 22.AUG.2013 22:20:27

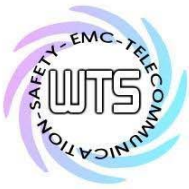

Report Number: W6M21308-13443-P-2224
FCC ID: GX9MX

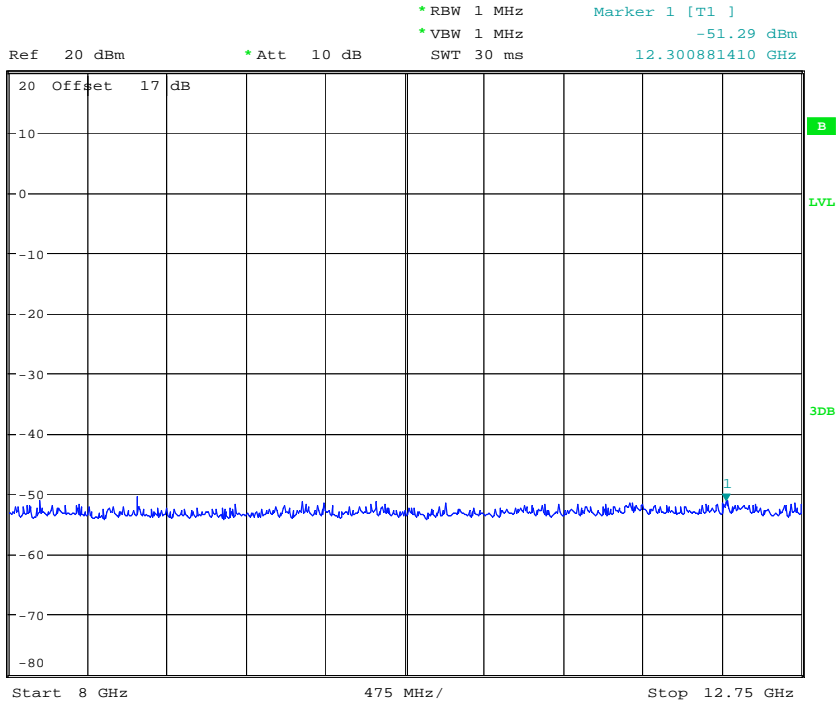

CONDUCTED SPURIOUS EMISSION GSM850 CH251

Date: 22.AUG.2013 22:20:44

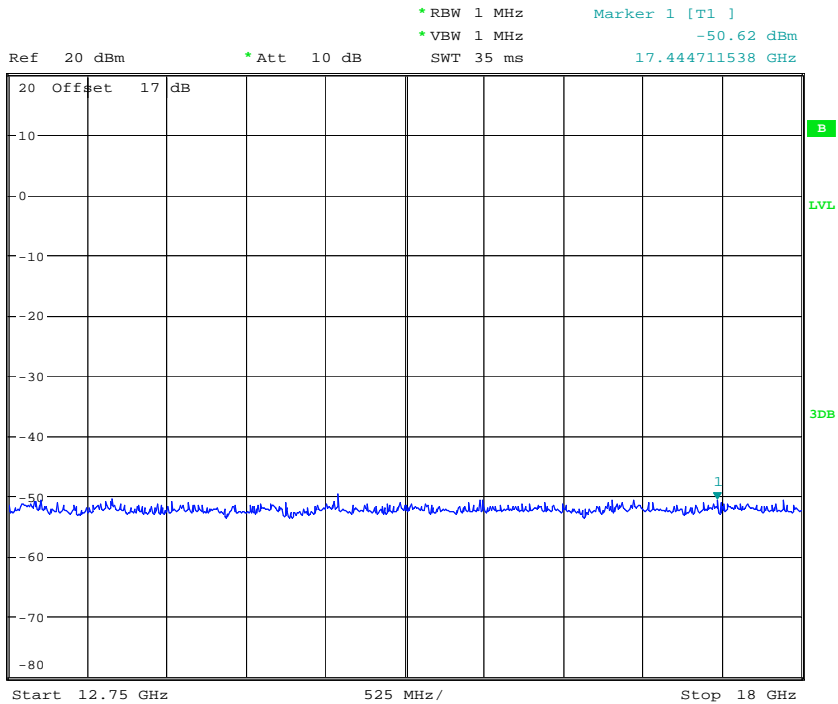

CONDUCTED SPURIOUS EMISSION GSM850 CH251

Date: 22.AUG.2013 22:22:54

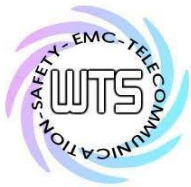

Report Number: W6M21308-13443-P-2224
FCC ID: GX9MX



*RBW 1 MHz Marker 1 [T1]
*VBW 1 MHz -48.25 dBm
SWT 50 ms 26.50000000 GHz

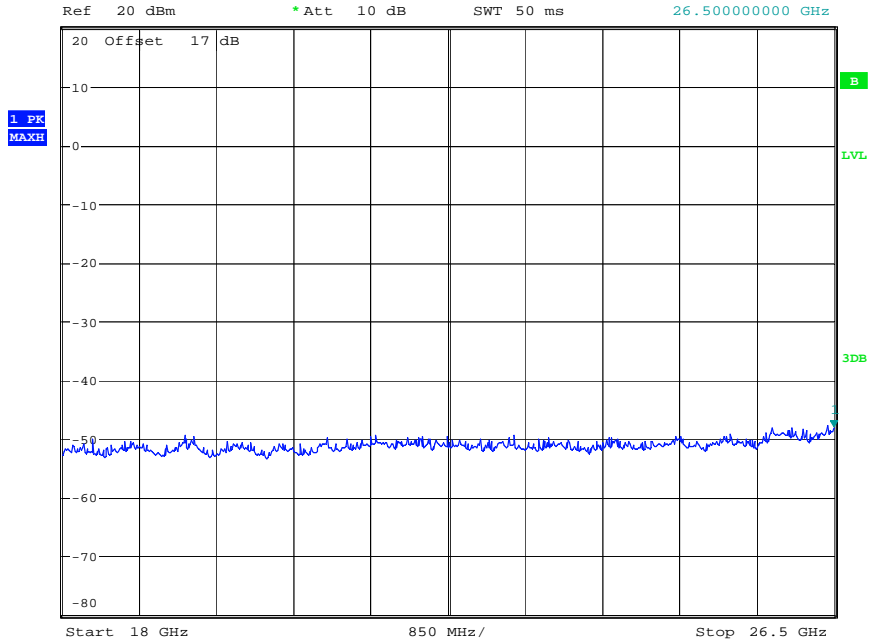

CONDUCTED SPURIOUS EMISSION GSM850 CH251
Date: 22.AUG.2013 22:23:18

850 Band Idle



*RBW 100 kHz Marker 1 [T1]
*VBW 100 kHz -57.46 dBm
SWT 100 ms 269.391025641 MHz

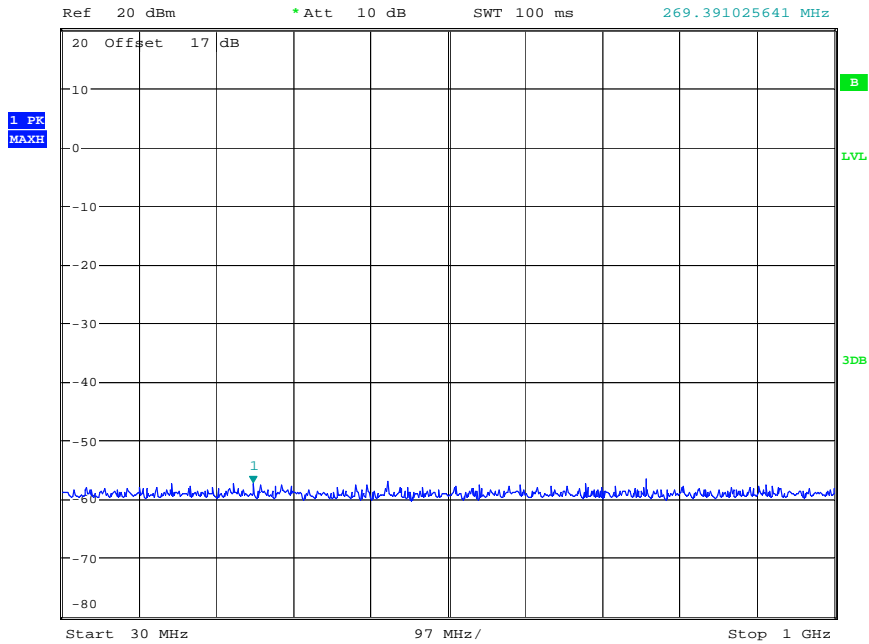

CONDUCTED SPURIOUS EMISSION GSM850 IDLE
Date: 22.AUG.2013 22:13:39

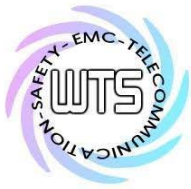

Report Number: W6M21308-13443-P-2224
FCC ID: GX9MX

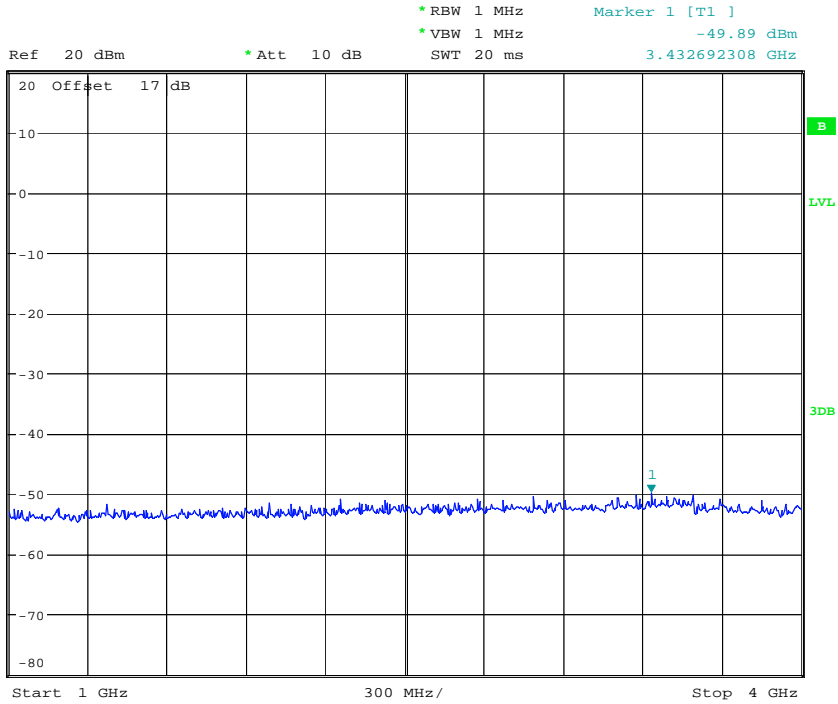

CONDUCTED SPURIOUS EMISSION GSM850 IDLE

Date: 22.AUG.2013 22:18:34

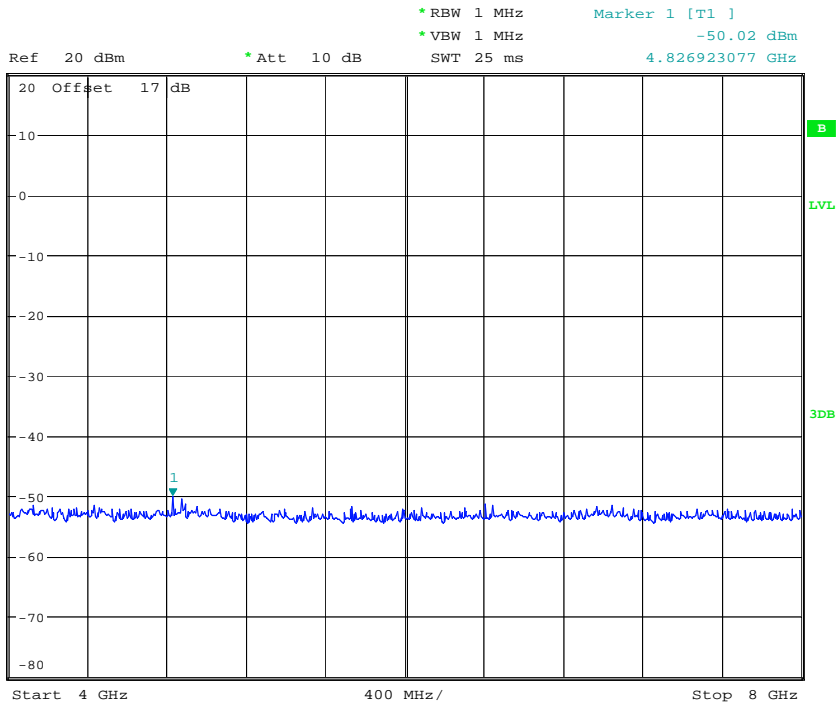

CONDUCTED SPURIOUS EMISSION GSM850 IDLE

Date: 22.AUG.2013 22:18:50

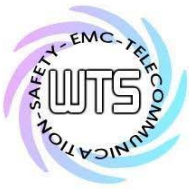

Report Number: W6M21308-13443-P-2224
FCC ID: GX9MX

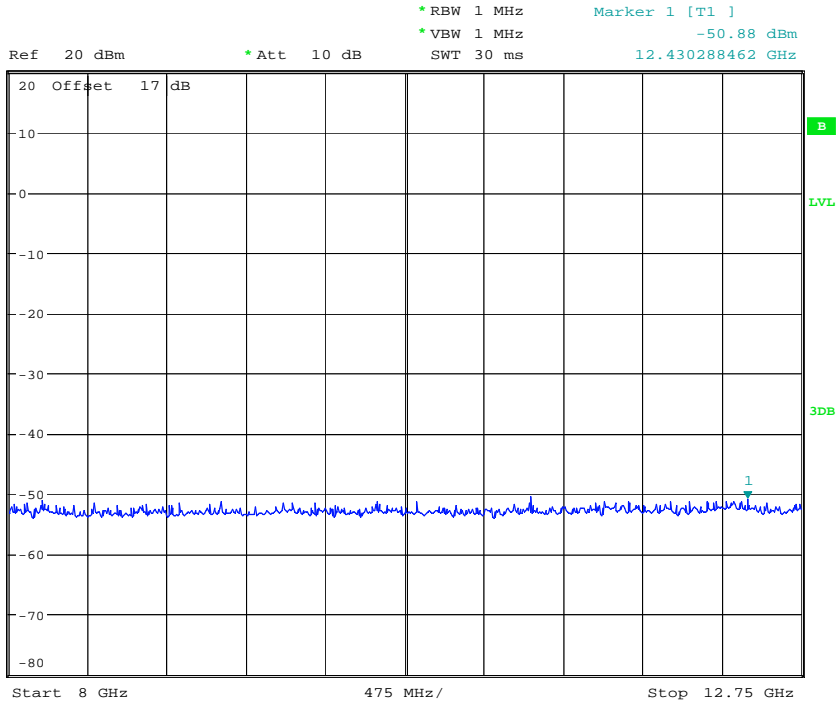

CONDUCTED SPURIOUS EMISSION GSM850 IDLE

Date: 22.AUG.2013 22:21:37

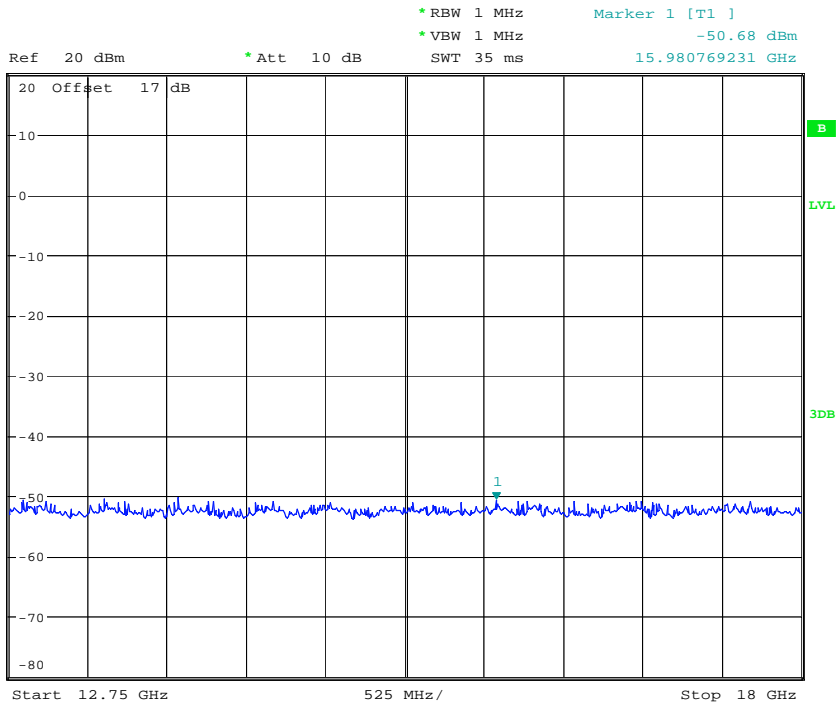

CONDUCTED SPURIOUS EMISSION GSM850 IDLE

Date: 22.AUG.2013 22:21:58

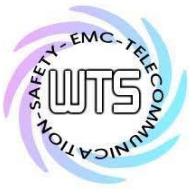

Report Number: W6M21308-13443-P-2224
FCC ID: GX9MX

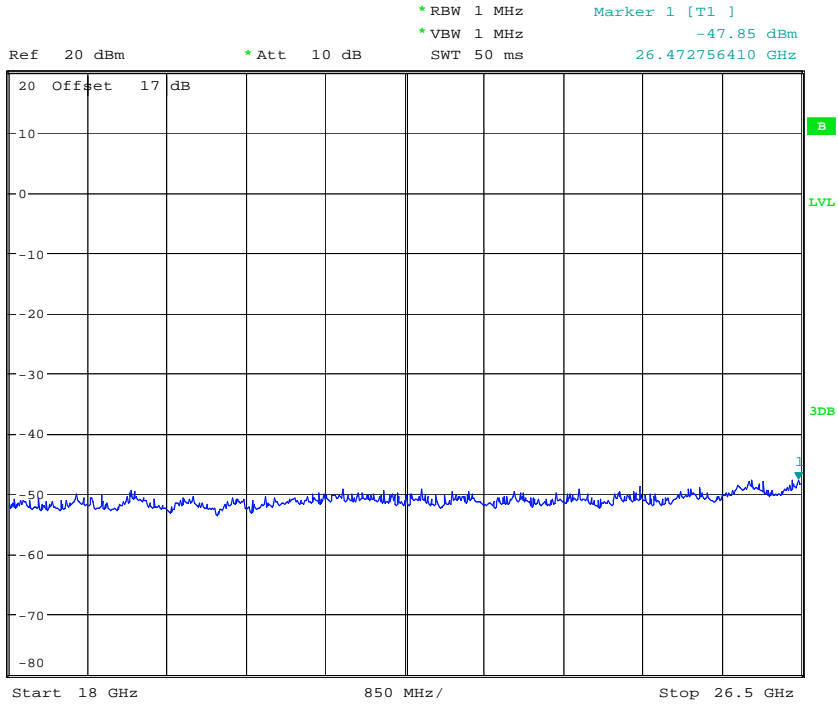

CONDUCTED SPURIOUS EMISSION GSM850 IDLE
Date: 22.AUG.2013 22:24:18

CH512

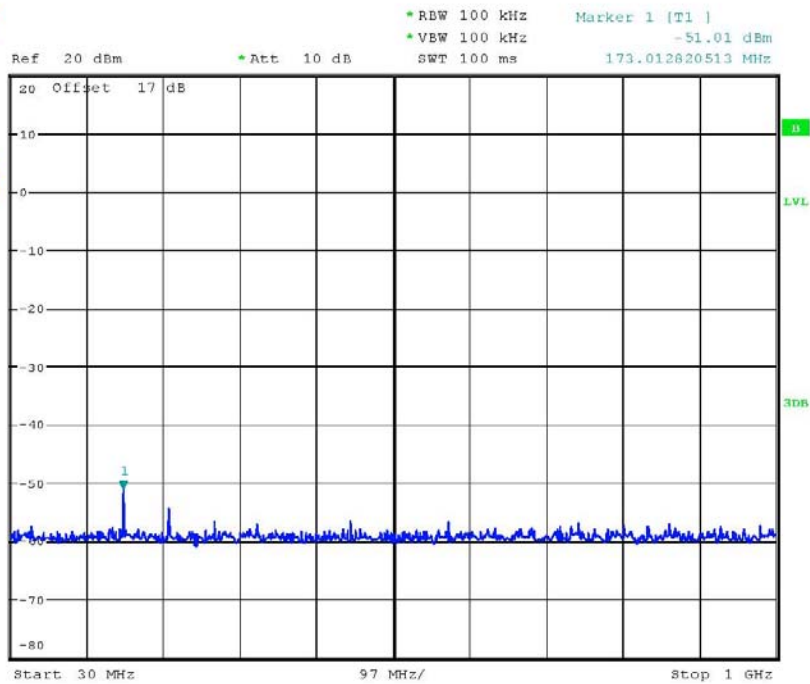

CONDUCTED SPURIOUS EMISSION PCS1900 CH512
Date: 22.AUG.2013 21:39:59

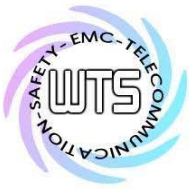

Report Number: W6M21308-13443-P-2224
FCC ID: GX9MX

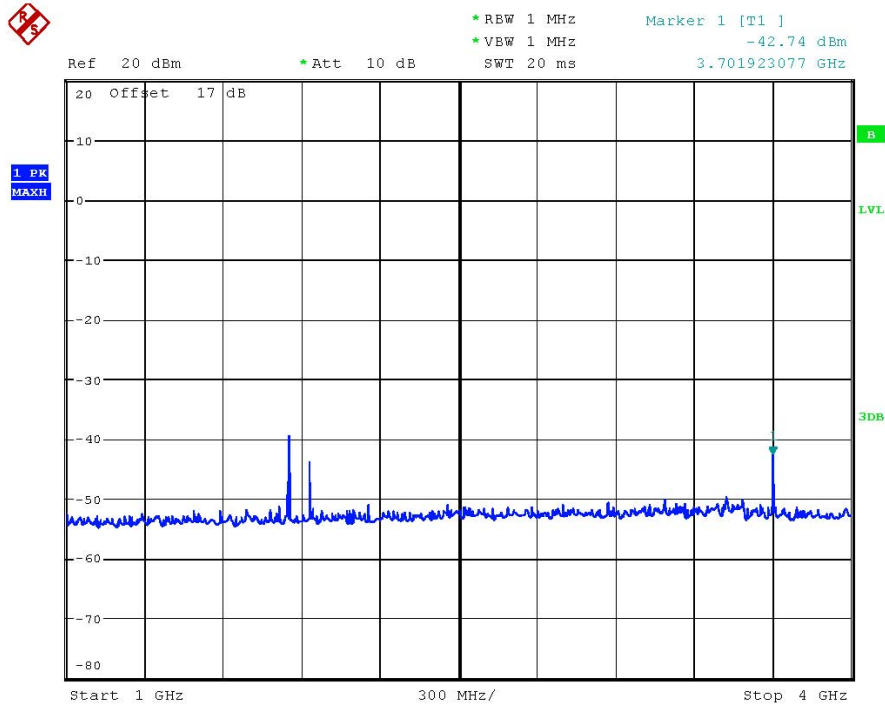

CONDUCTED SPURIOUS EMISSION PCS1900 CH512
Date: 22.AUG.2013 21:43:15

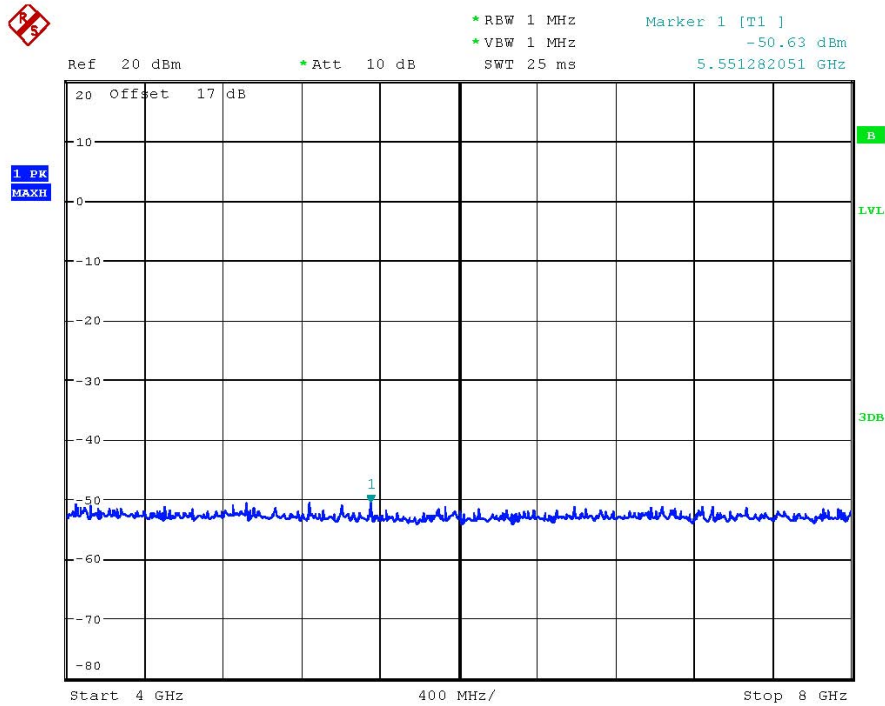

CONDUCTED SPURIOUS EMISSION PCS1900 CH512
Date: 22.AUG.2013 21:46:11

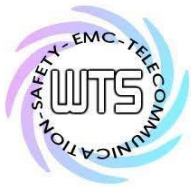

Report Number: W6M21308-13443-P-2224
FCC ID: GX9MX

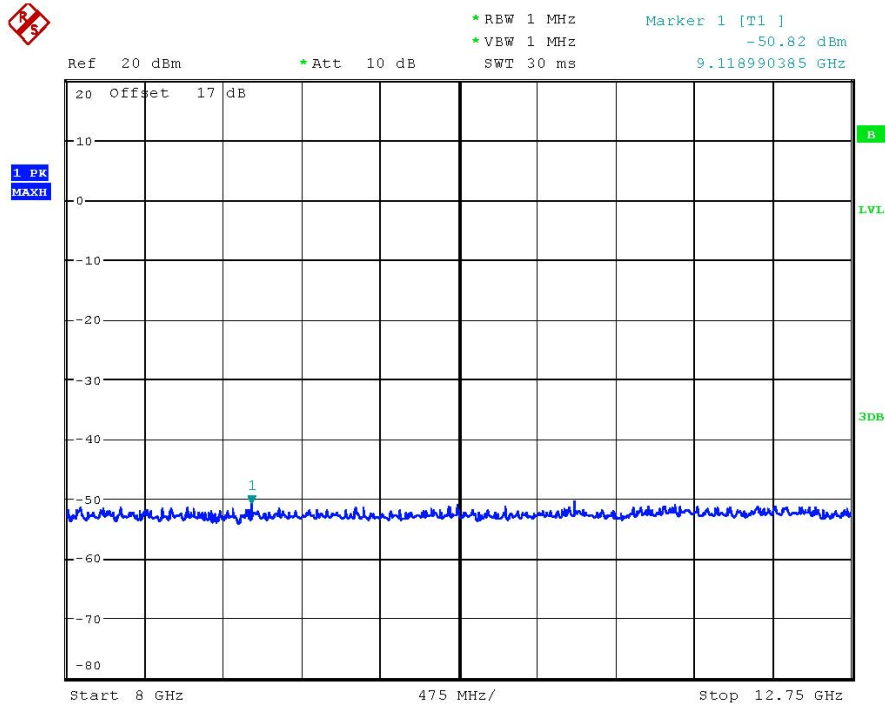

CONDUCTED SPURIOUS EMISSION PCS1900 CH512
Date: 22.AUG.2013 21:49:09

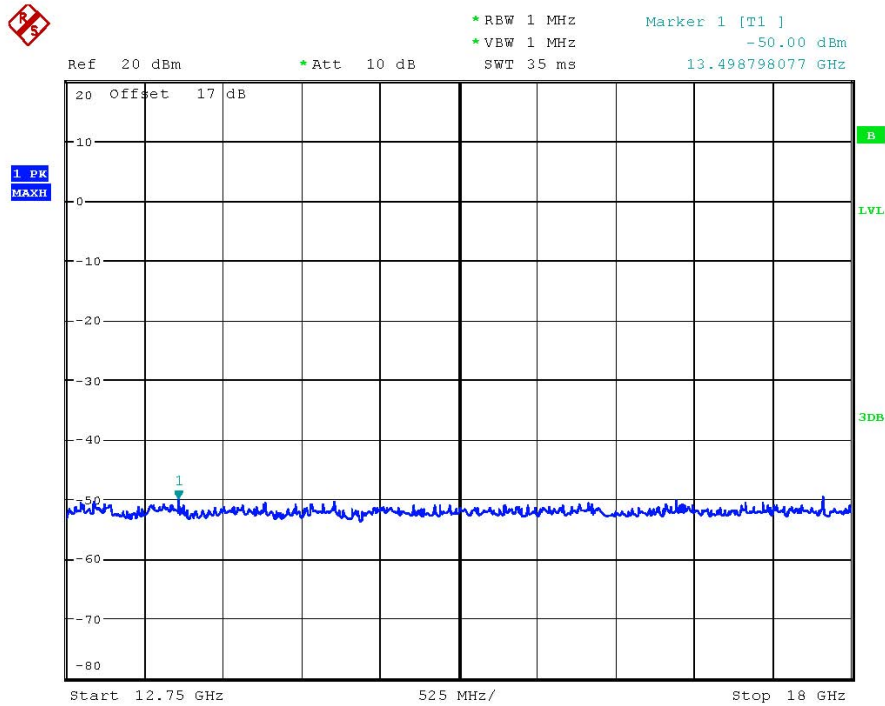

CONDUCTED SPURIOUS EMISSION PCS1900 CH512
Date: 22.AUG.2013 21:50:23



Report Number: W6M21308-13443-P-2224
FCC ID: GX9MX

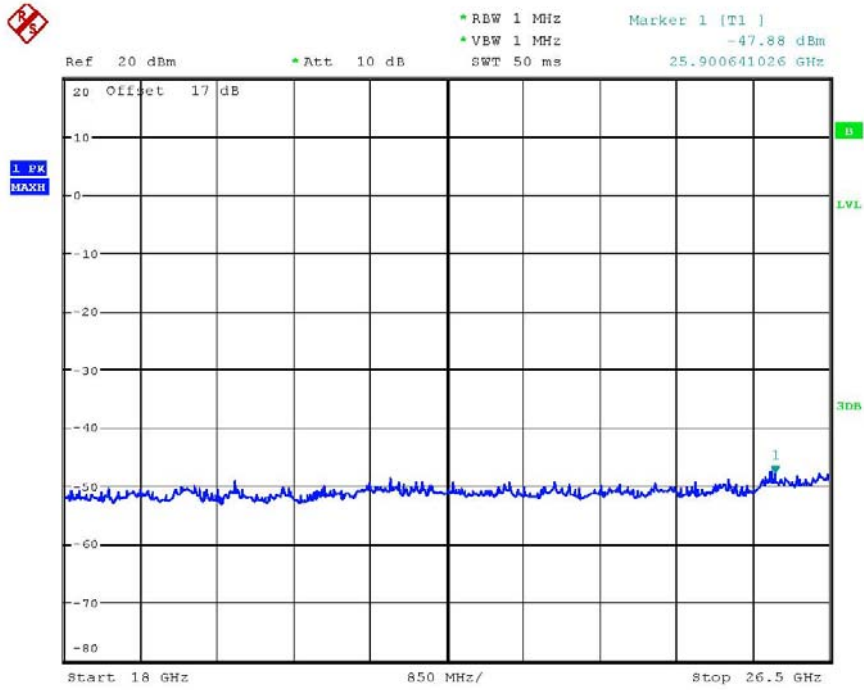

CONDUCTED SPURIOUS EMISSION PCS1900 CH512
Date: 22.AUG.2013 21:51:56

CH661

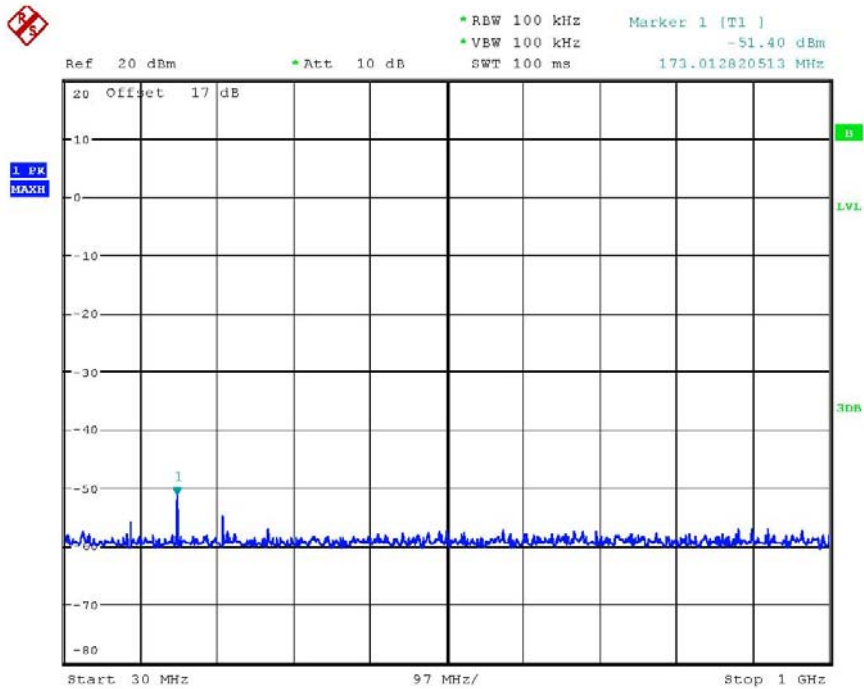

CONDUCTED SPURIOUS EMISSION PCS1900 CH661
Date: 22.AUG.2013 21:40:33



Report Number: W6M21308-13443-P-2224
FCC ID: GX9MX

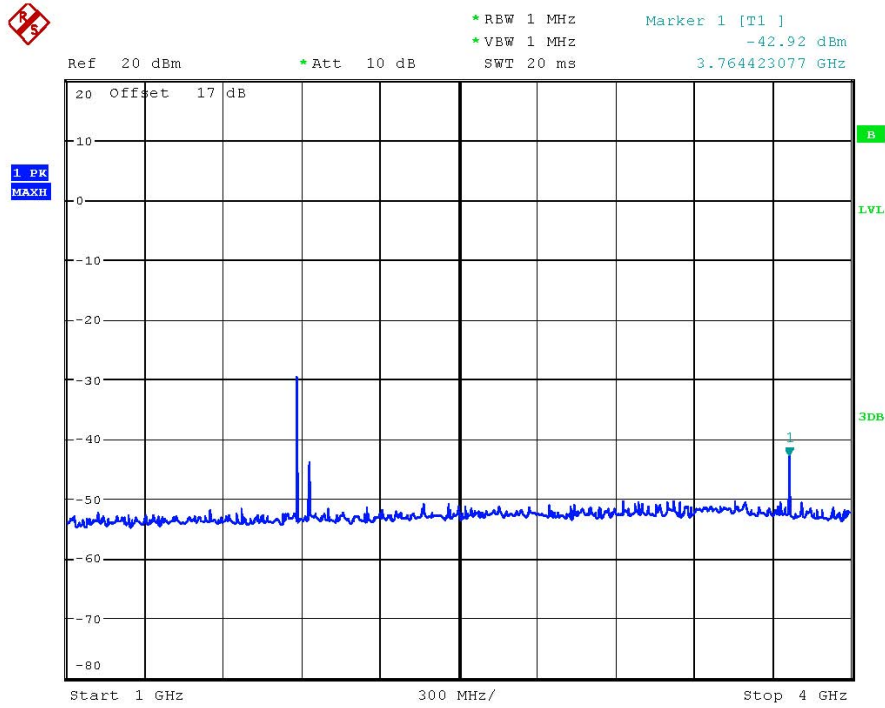

CONDUCTED SPURIOUS EMISSION PCS1900 CH661
Date: 22.AUG.2013 21:44:48

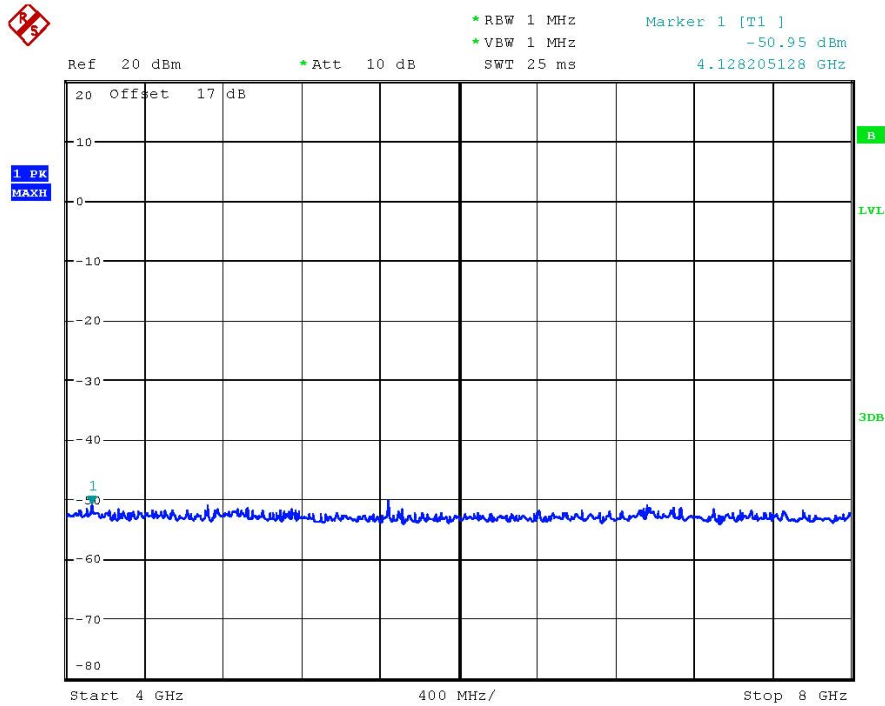

CONDUCTED SPURIOUS EMISSION PCS1900 CH661
Date: 22.AUG.2013 21:45:50

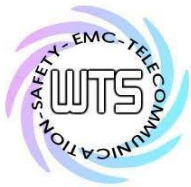

Worldwide Testing Services(Taiwan) Co., Ltd.

Report Number: W6M21308-13443-P-2224

FCC ID: GX9MX

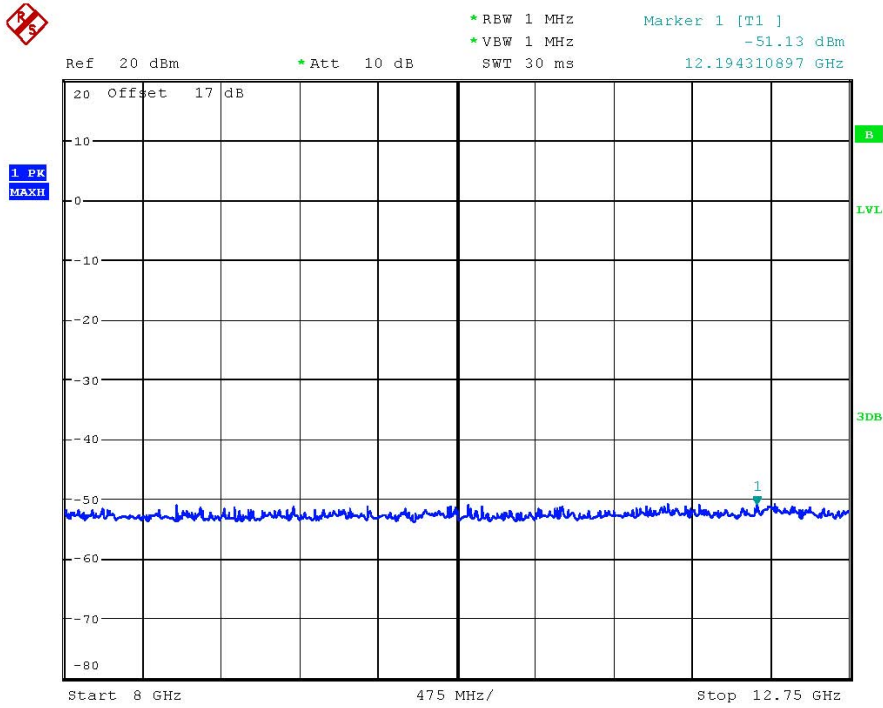

CONDUCTED SPURIOUS EMISSION PCS1900 CH661

Date: 22.AUG.2013 21:48:47

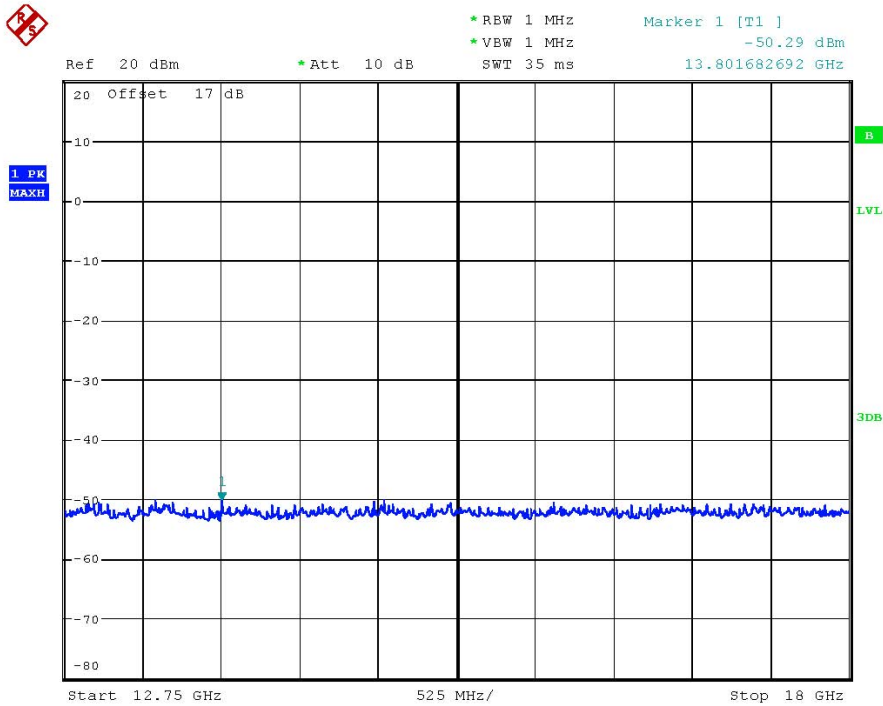

CONDUCTED SPURIOUS EMISSION PCS1900 CH661

Date: 22.AUG.2013 21:50:37



Report Number: W6M21308-13443-P-2224
FCC ID: GX9MX

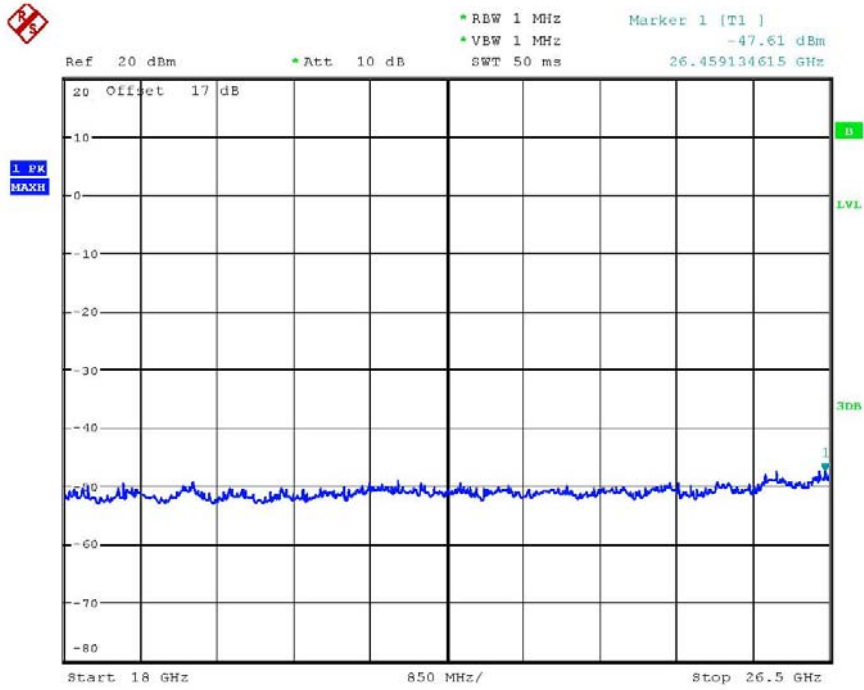

CONDUCTED SPURIOUS EMISSION PCS1900 CH661
Date: 22.AUG.2013 21:51:41

CH810

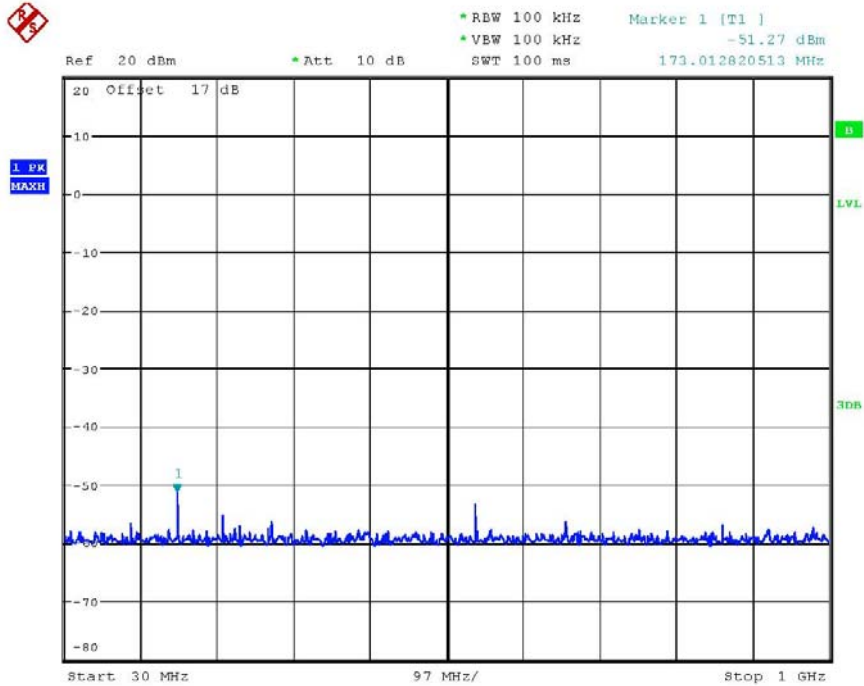

CONDUCTED SPURIOUS EMISSION PCS1900 CH810
Date: 22.AUG.2013 21:40:59

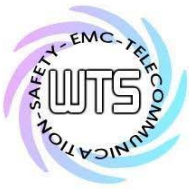

Report Number: W6M21308-13443-P-2224
FCC ID: GX9MX

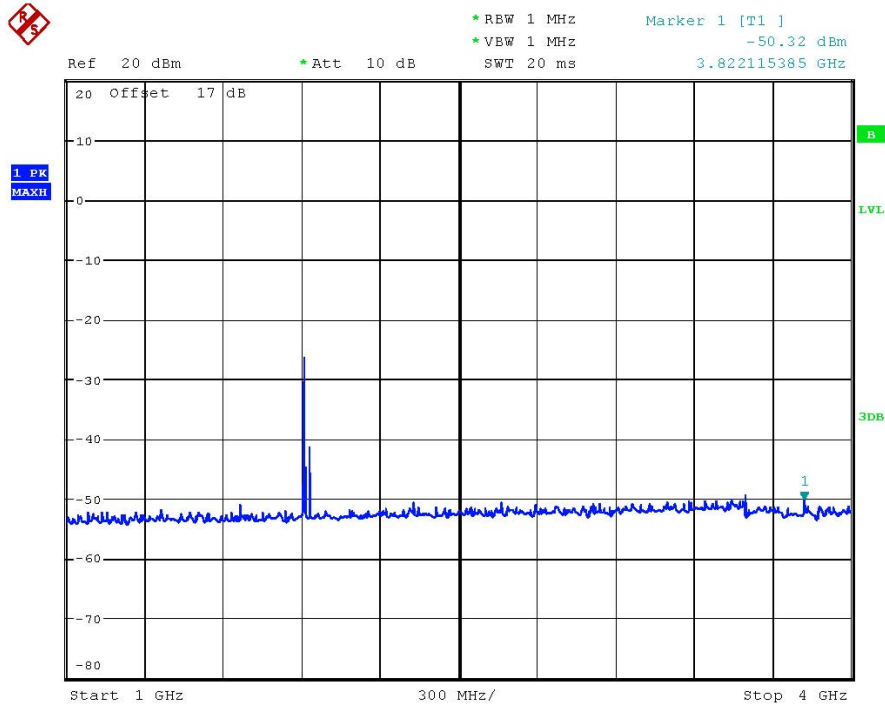

CONDUCTED SPURIOUS EMISSION PCS1900 CH810
Date: 22.AUG.2013 21:55:12

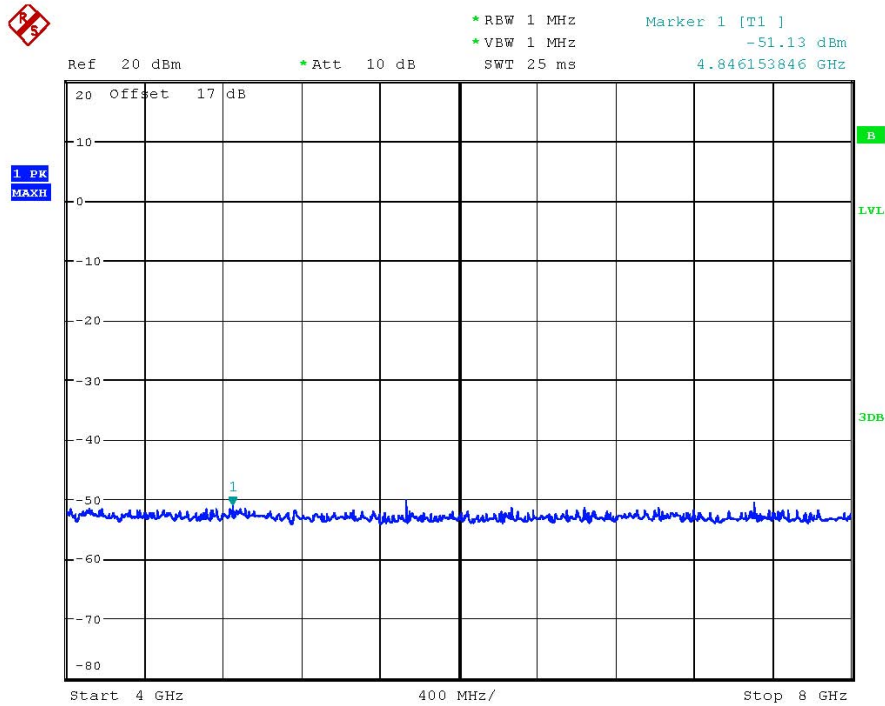

CONDUCTED SPURIOUS EMISSION PCS1900 CH810
Date: 22.AUG.2013 21:45:30



Report Number: W6M21308-13443-P-2224
FCC ID: GX9MX

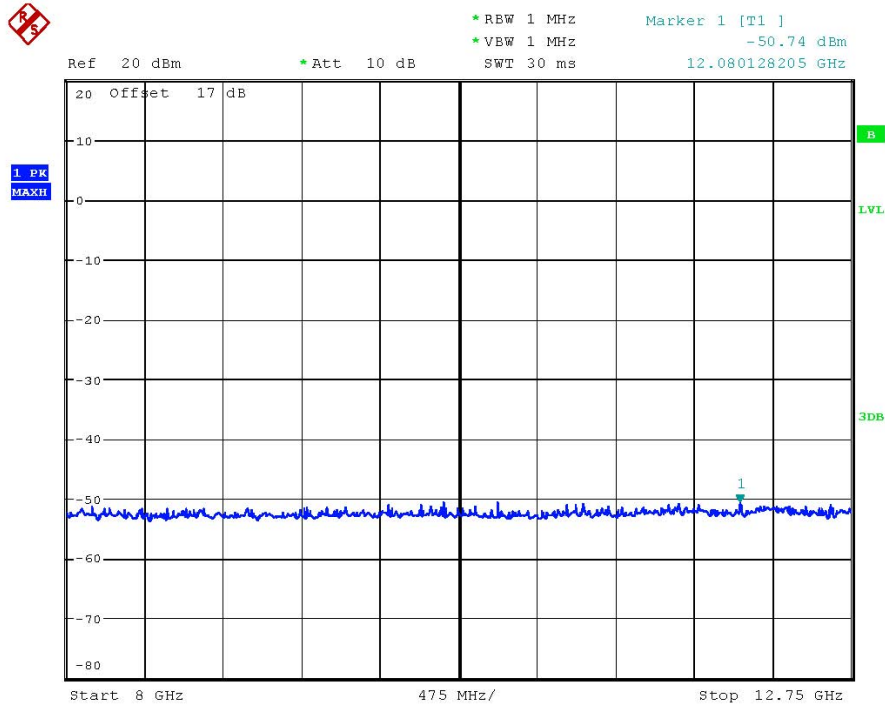

CONDUCTED SPURIOUS EMISSION PCS1900 CH810
Date: 22.AUG.2013 21:48:28

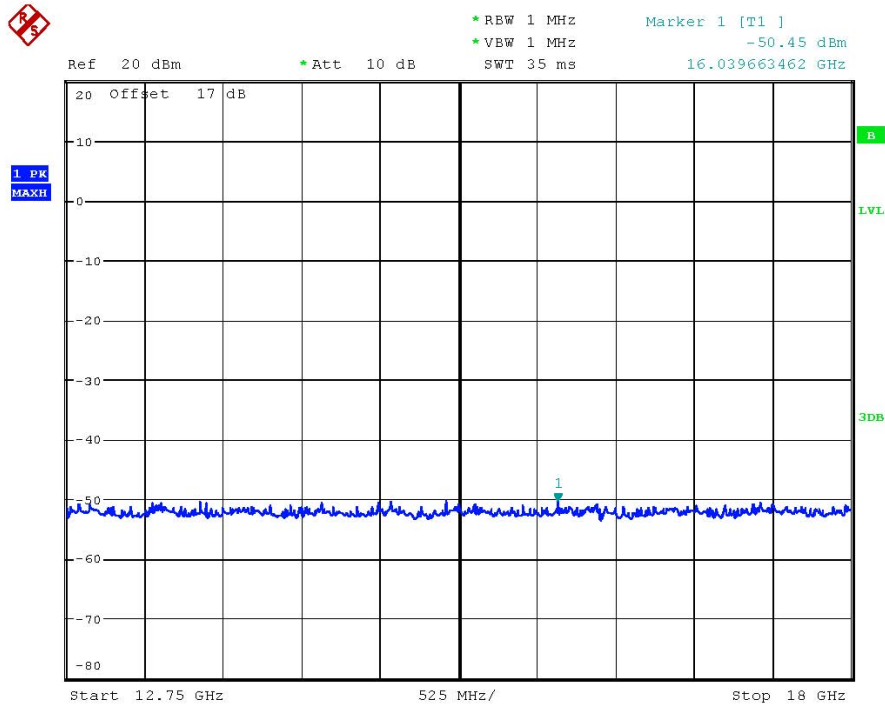

CONDUCTED SPURIOUS EMISSION PCS1900 CH810
Date: 22.AUG.2013 21:50:54



Report Number: W6M21308-13443-P-2224
FCC ID: GX9MX

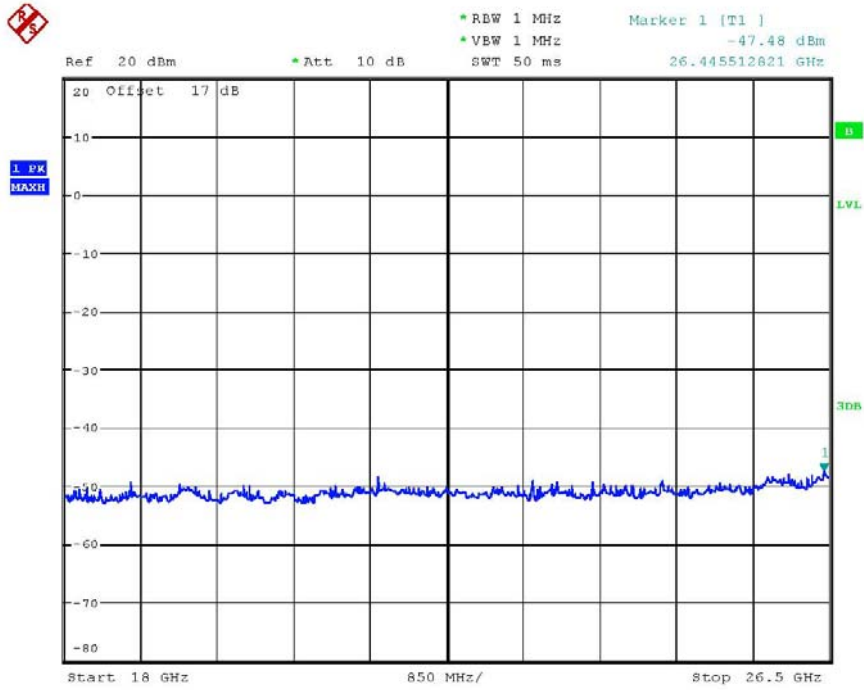

CONDUCTED SPURIOUS EMISSION PCS1900 CH810
Date: 22.AUG.2013 21:51:27

1900 Band Idle

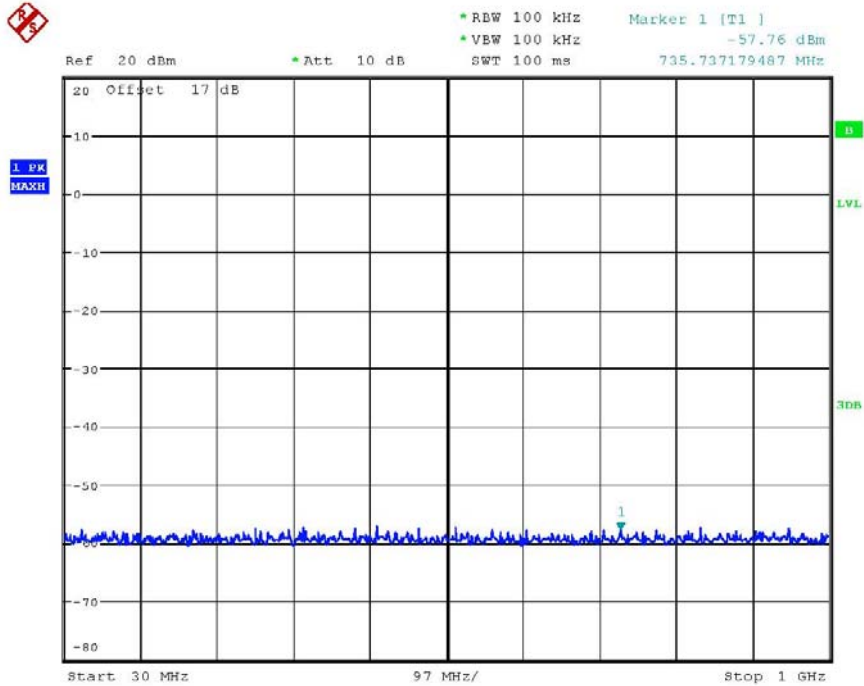

CONDUCTED SPURIOUS EMISSION PCS1900 IDLE
Date: 22.AUG.2013 21:42:17

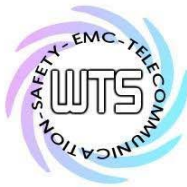

Worldwide Testing Services(Taiwan) Co., Ltd.

Report Number: W6M21308-13443-P-2224
 FCC ID: GX9MX

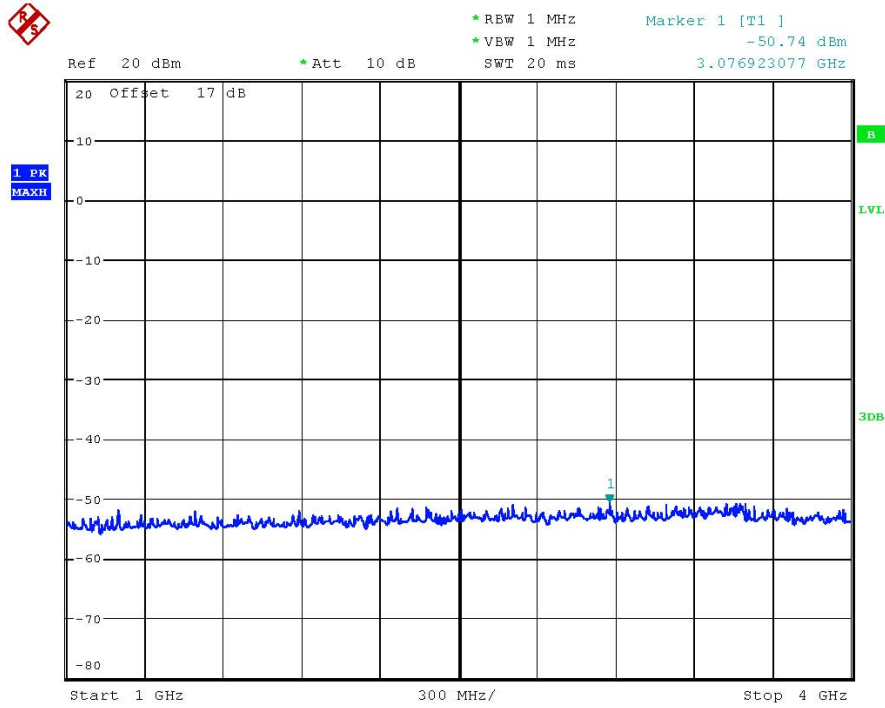

CONDUCTED SPURIOUS EMISSION PCS1900 IDLE
 Date: 22.AUG.2013 21:56:13

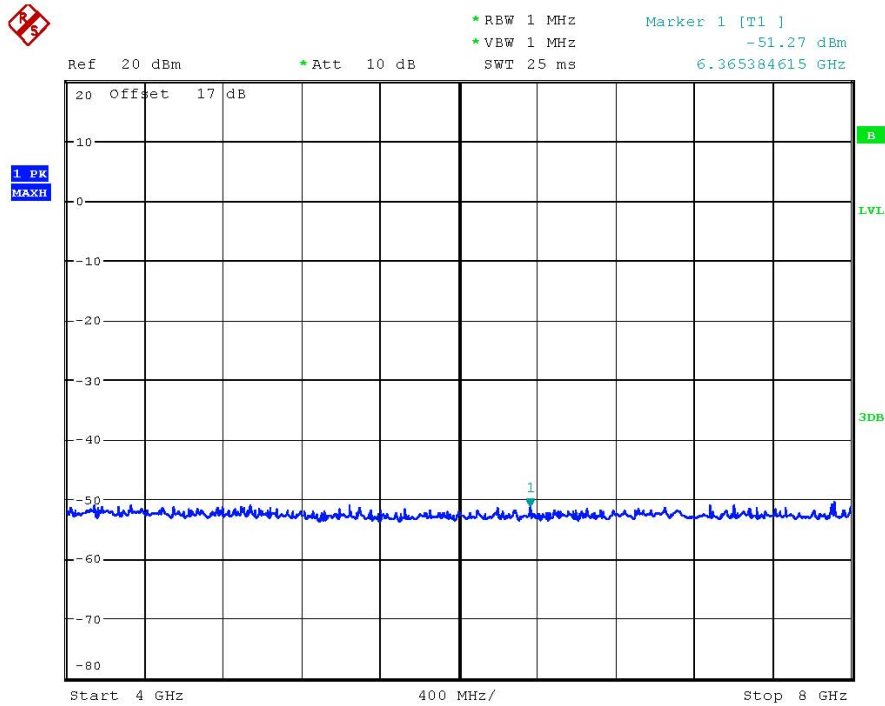

CONDUCTED SPURIOUS EMISSION PCS1900 IDLE
 Date: 22.AUG.2013 21:46:45



Report Number: W6M21308-13443-P-2224
FCC ID: GX9MX

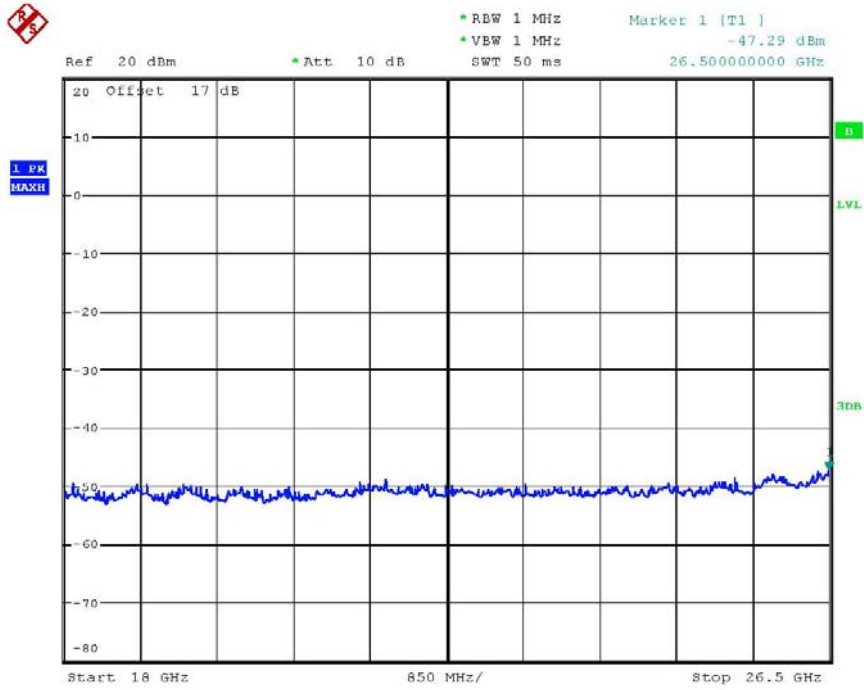

CONDUCTED SPURIOUS EMISSION PCS1900 IDLE
Date: 22.AUG.2013 21:52:14

CH9262

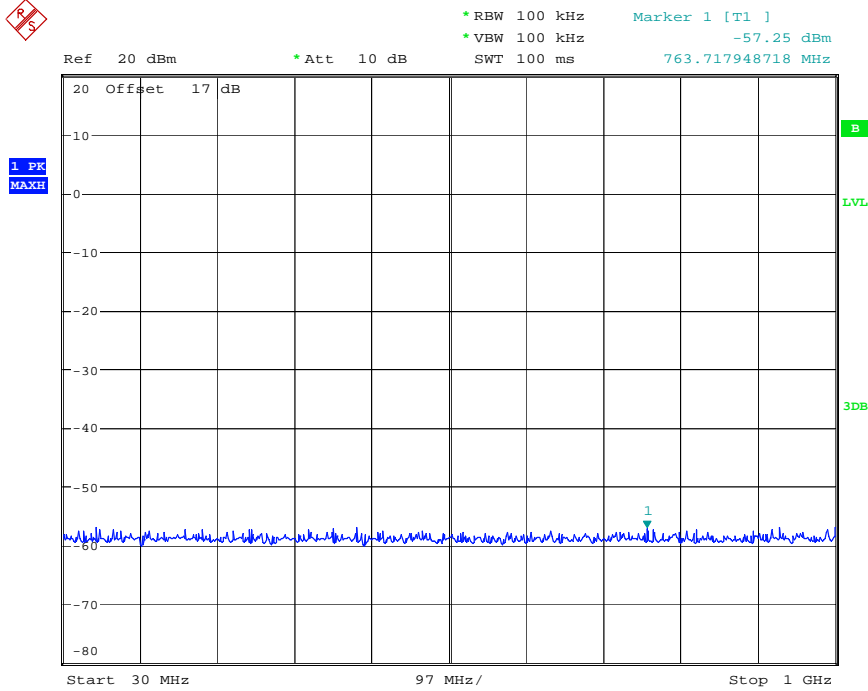

CONDUCTED SPURIOUS EMISSION WCDMA BAND II CH9262
Date: 22.AUG.2013 21:19:20

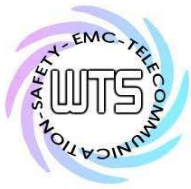

Report Number: W6M21308-13443-P-2224
FCC ID: GX9MX

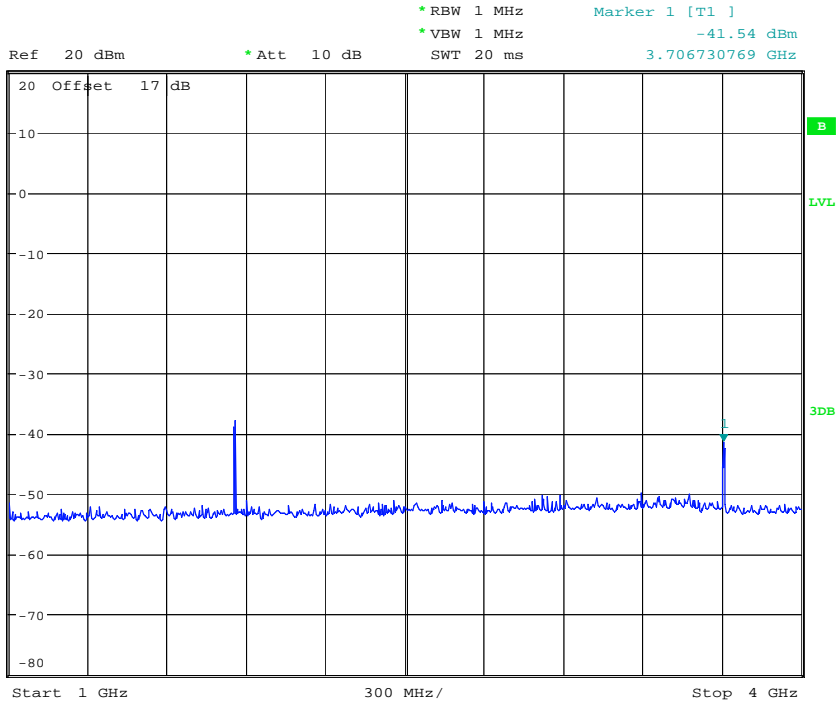

CONDUCTED SPURIOUS EMISSION WCDMA BAND II CH9262

Date: 22.AUG.2013 21:23:08

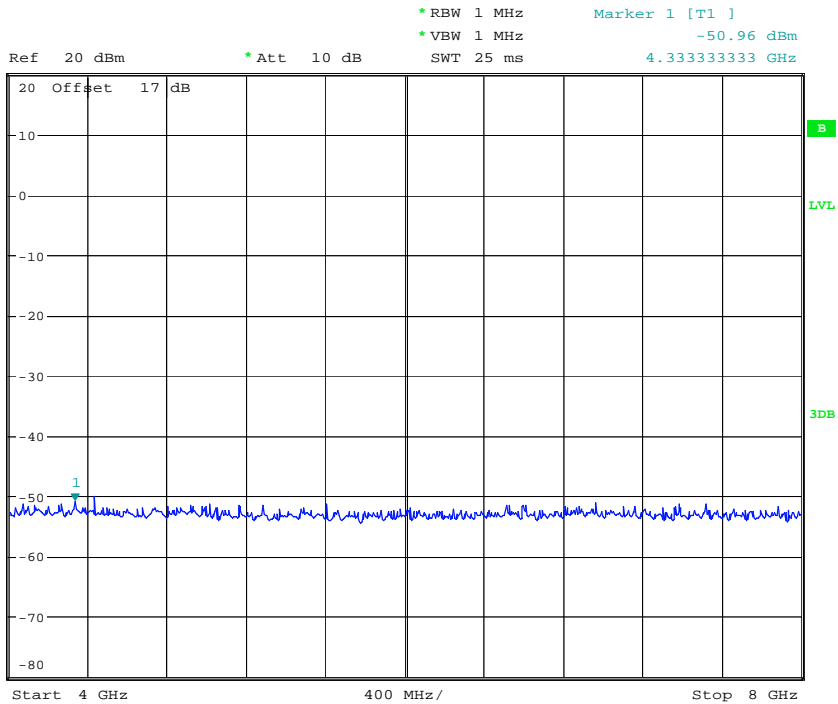

CONDUCTED SPURIOUS EMISSION WCDMA BAND II CH9262

Date: 22.AUG.2013 21:27:15

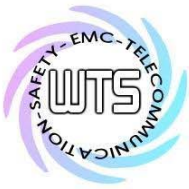

Report Number: W6M21308-13443-P-2224
FCC ID: GX9MX

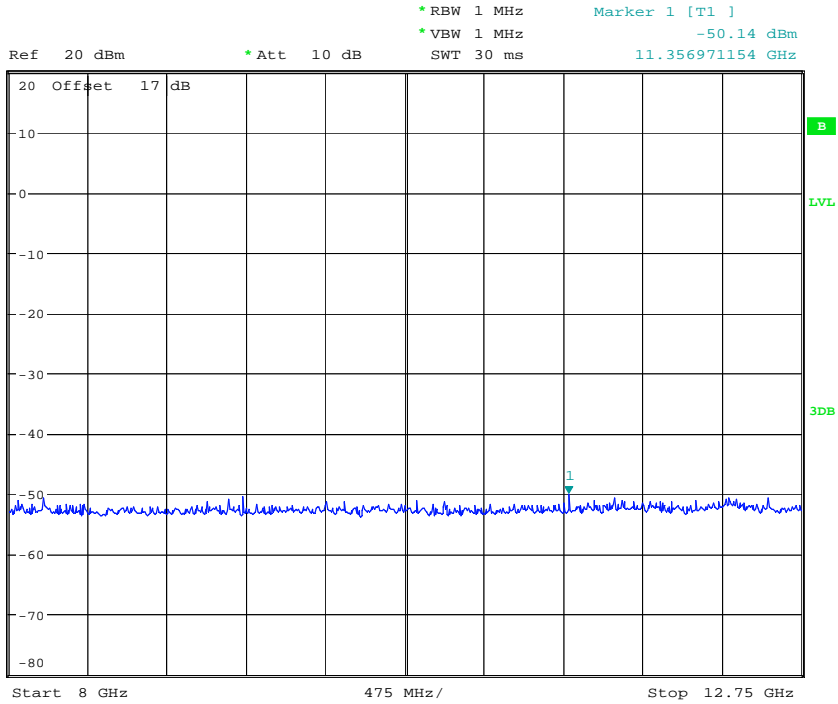

CONDUCTED SPURIOUS EMISSION WCDMA BAND II CH9262

Date: 22.AUG.2013 21:28:23

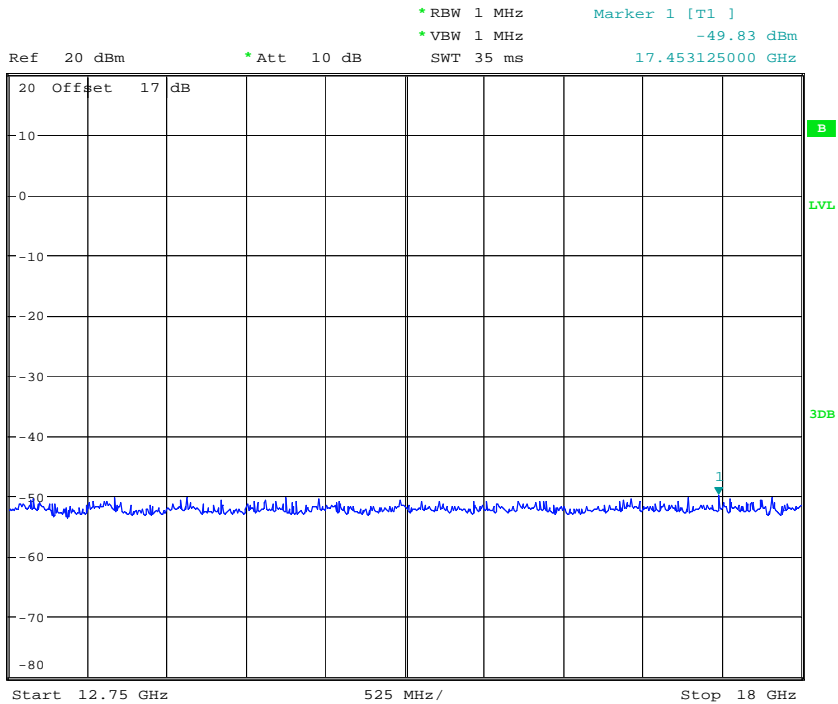

CONDUCTED SPURIOUS EMISSION WCDMA BAND II CH9262

Date: 22.AUG.2013 21:30:03

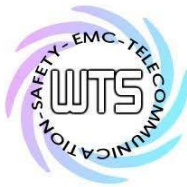

Report Number: W6M21308-13443-P-2224
FCC ID: GX9MX

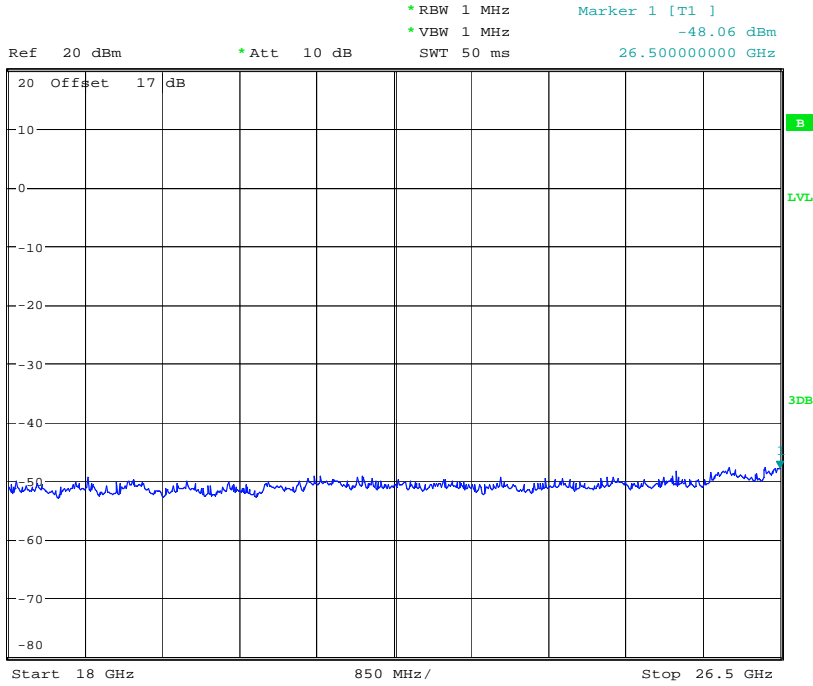

CONDUCTED SPURIOUS EMISSION WCDMA BAND II CH9262
Date: 22.AUG.2013 21:32:01

CH9400

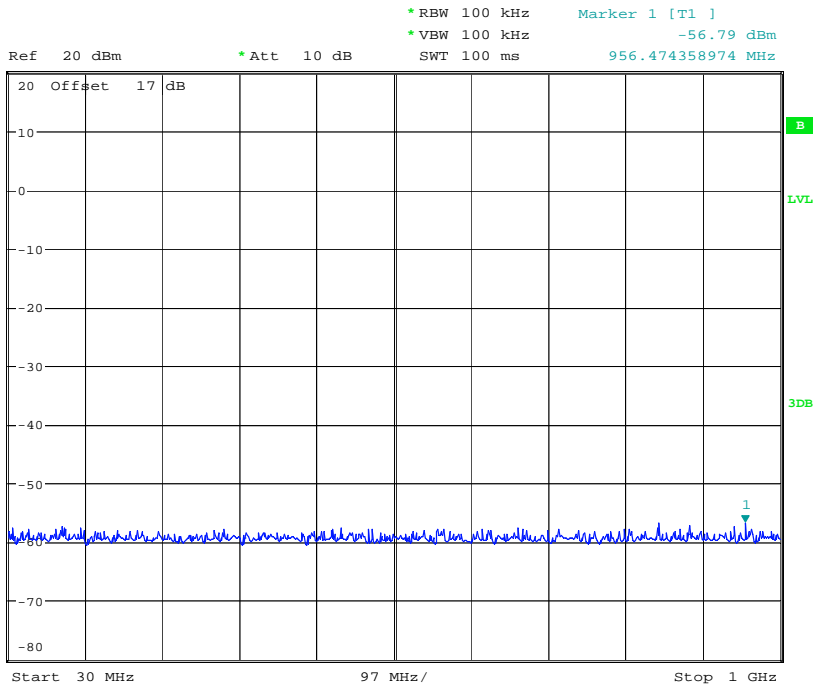

CONDUCTED SPURIOUS EMISSION WCDMA BAND II CH9400
Date: 22.AUG.2013 21:19:48

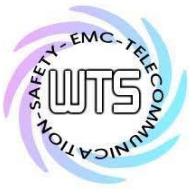

Report Number: W6M21308-13443-P-2224
FCC ID: GX9MX

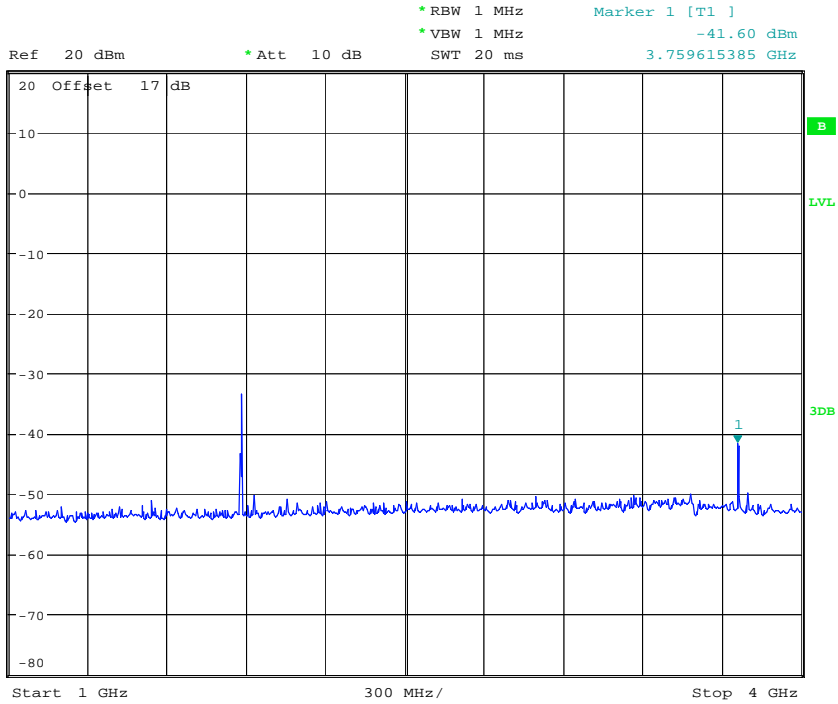

CONDUCTED SPURIOUS EMISSION WCDMA BAND II CH9400

Date: 22.AUG.2013 21:23:48

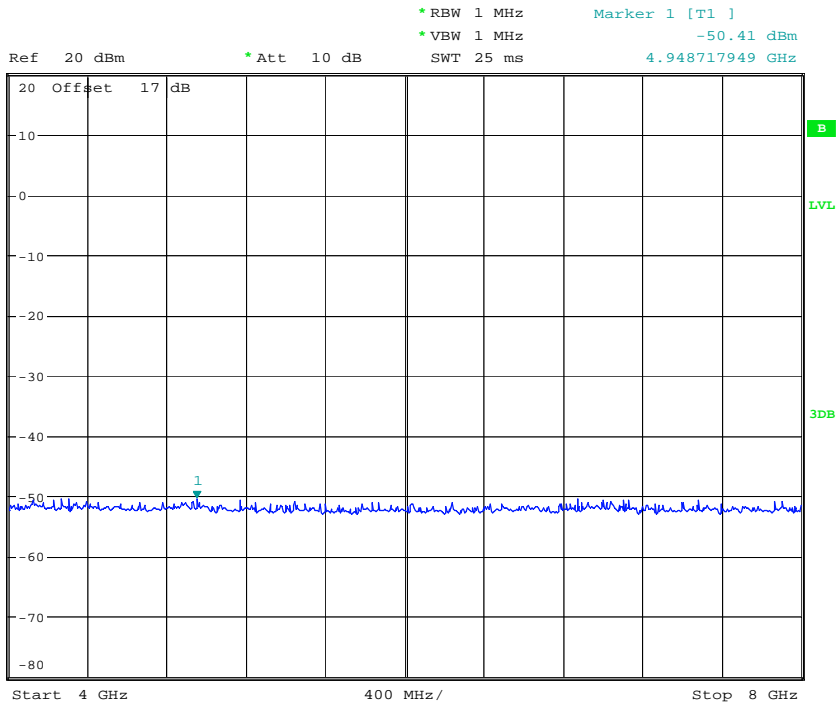

CONDUCTED SPURIOUS EMISSION WCDMA BAND II CH9400

Date: 22.AUG.2013 21:26:51

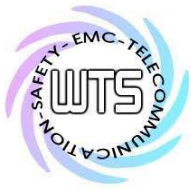

Report Number: W6M21308-13443-P-2224
FCC ID: GX9MX

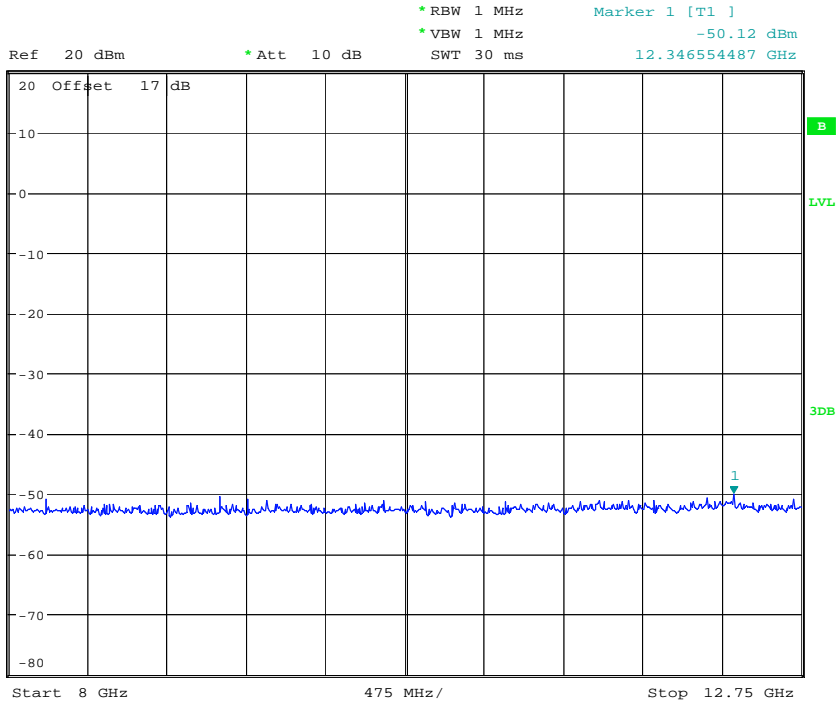

CONDUCTED SPURIOUS EMISSION WCDMA BAND II CH9400

Date: 22.AUG.2013 21:28:53

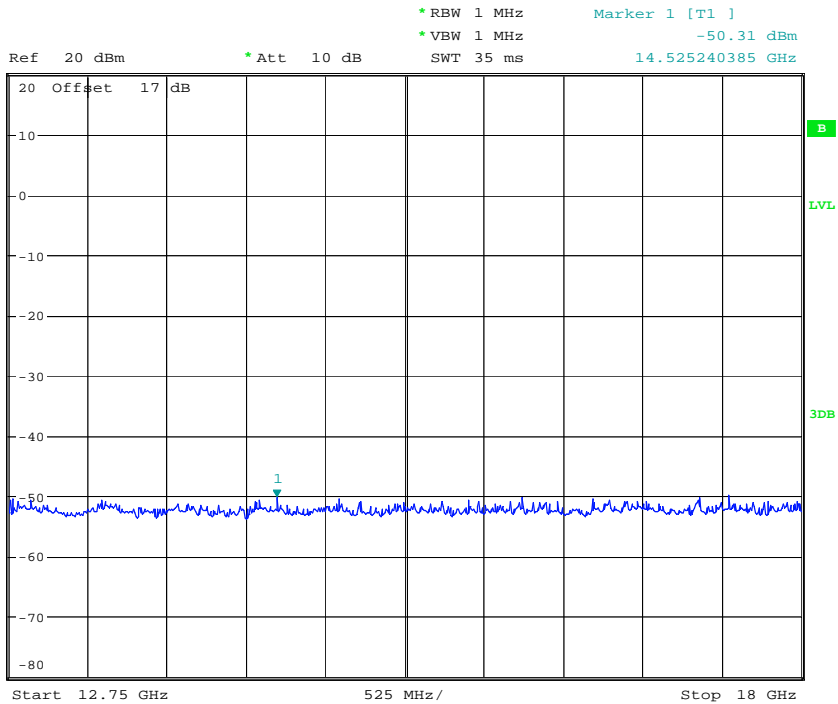

CONDUCTED SPURIOUS EMISSION WCDMA BAND II CH9400

Date: 22.AUG.2013 21:30:18

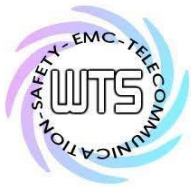

Report Number: W6M21308-13443-P-2224
FCC ID: GX9MX

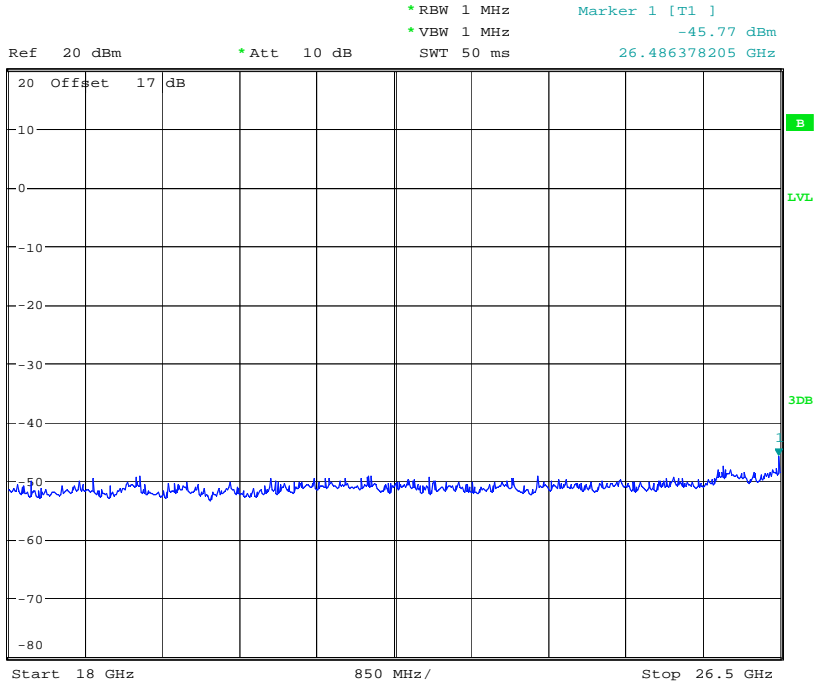

CONDUCTED SPURIOUS EMISSION WCDMA BAND II CH9400

Date: 22.AUG.2013 21:31:31

CH9538

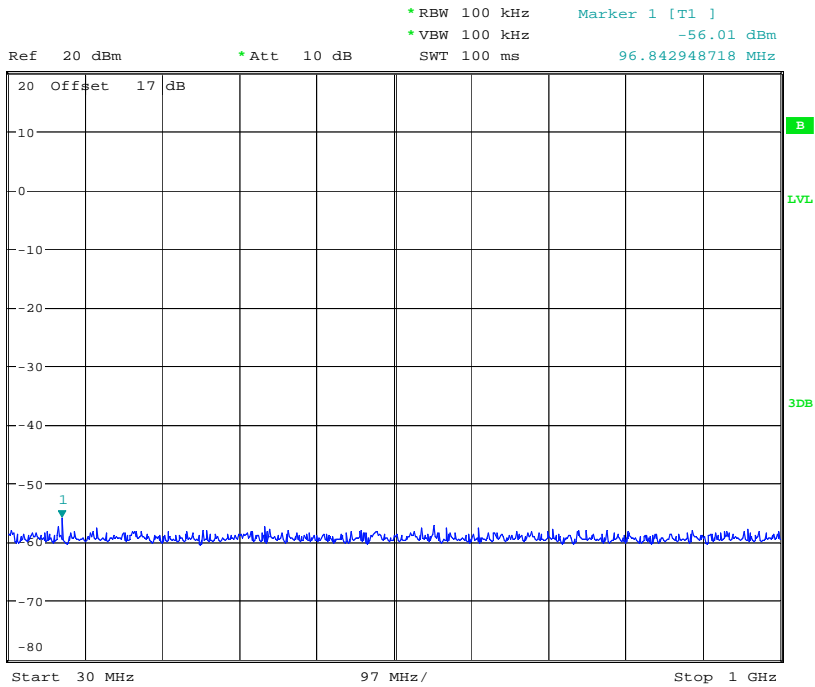

CONDUCTED SPURIOUS EMISSION WCDMA BAND II CH9538

Date: 22.AUG.2013 21:20:12

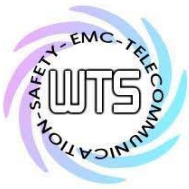

Report Number: W6M21308-13443-P-2224
FCC ID: GX9MX

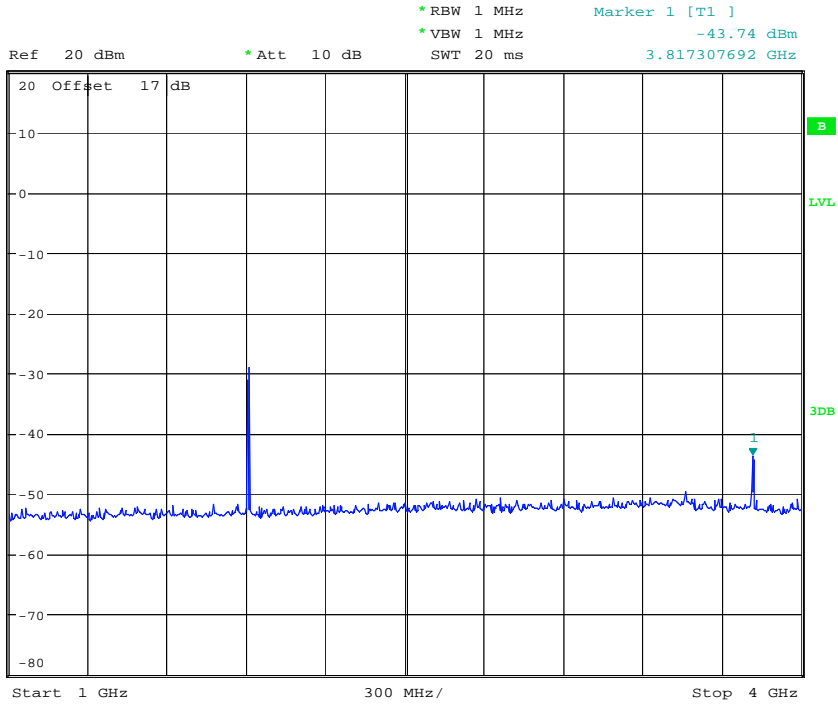

CONDUCTED SPURIOUS EMISSION WCDMA BAND II CH9538

Date: 22.AUG.2013 21:22:32

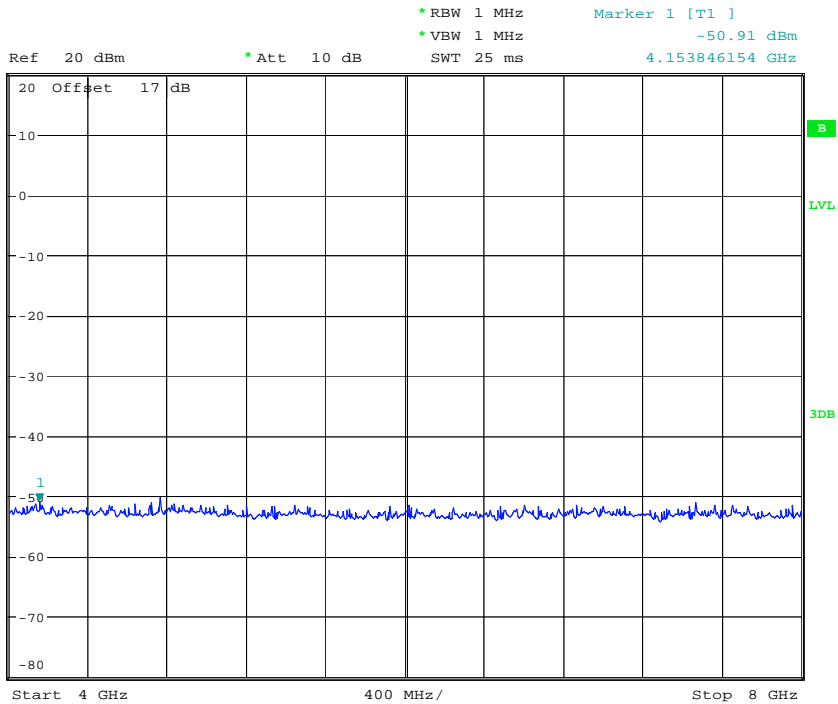

CONDUCTED SPURIOUS EMISSION WCDMA BAND II CH9538

Date: 22.AUG.2013 21:27:36

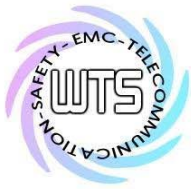

Report Number: W6M21308-13443-P-2224
FCC ID: GX9MX

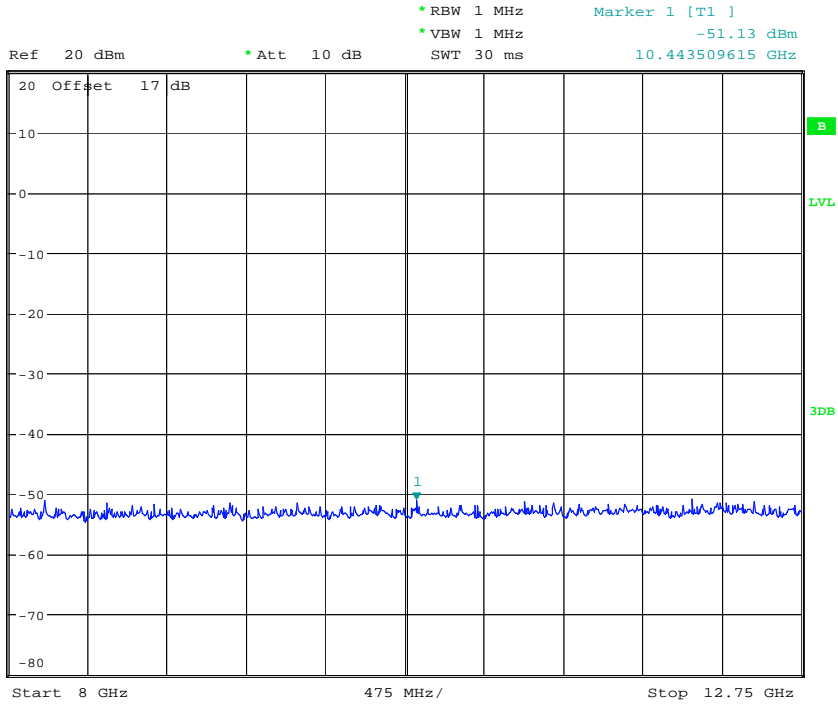

CONDUCTED SPURIOUS EMISSION WCDMA BAND II CH9538

Date: 22.AUG.2013 21:27:55

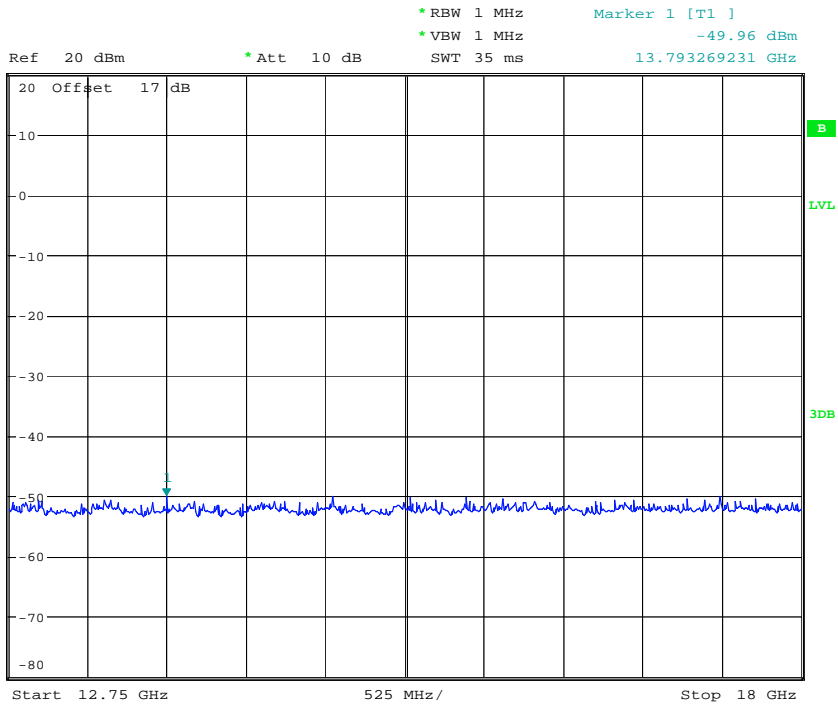

CONDUCTED SPURIOUS EMISSION WCDMA BAND II CH9538

Date: 22.AUG.2013 21:30:38

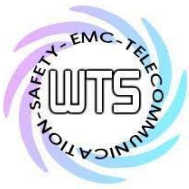

Report Number: W6M21308-13443-P-2224
FCC ID: GX9MX

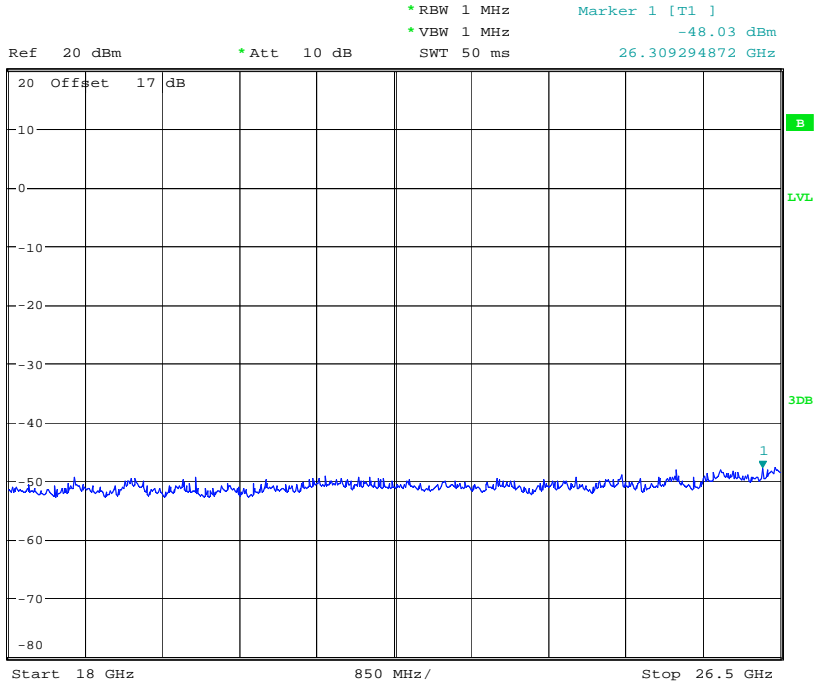

CONDUCTED SPURIOUS EMISSION WCDMA BAND II CH9538
Date: 22.AUG.2013 21:31:13

Band II Idle

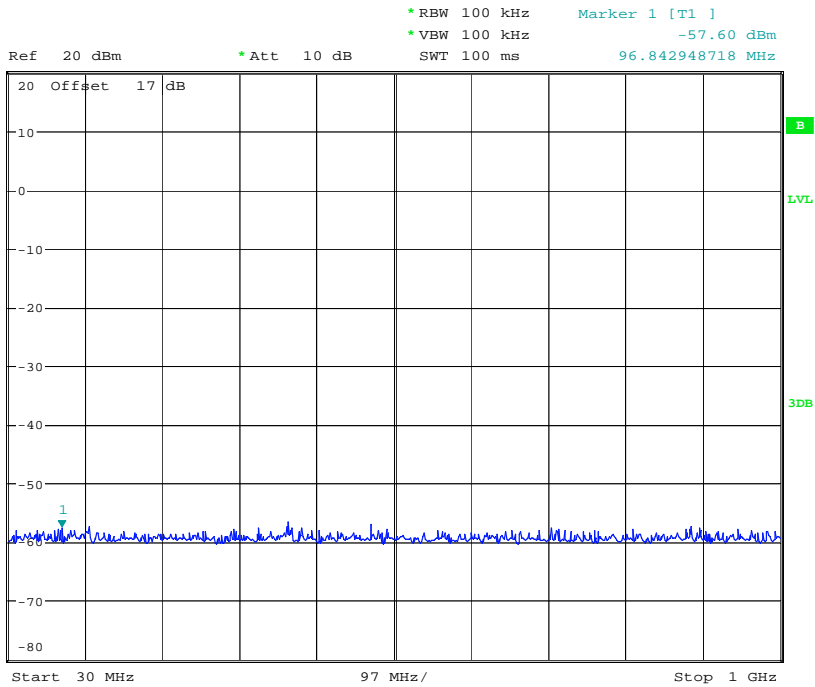

CONDUCTED SPURIOUS EMISSION WCDMA BAND II IDLE
Date: 22.AUG.2013 21:20:34

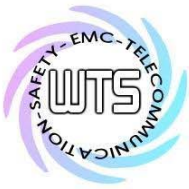

Report Number: W6M21308-13443-P-2224
FCC ID: GX9MX

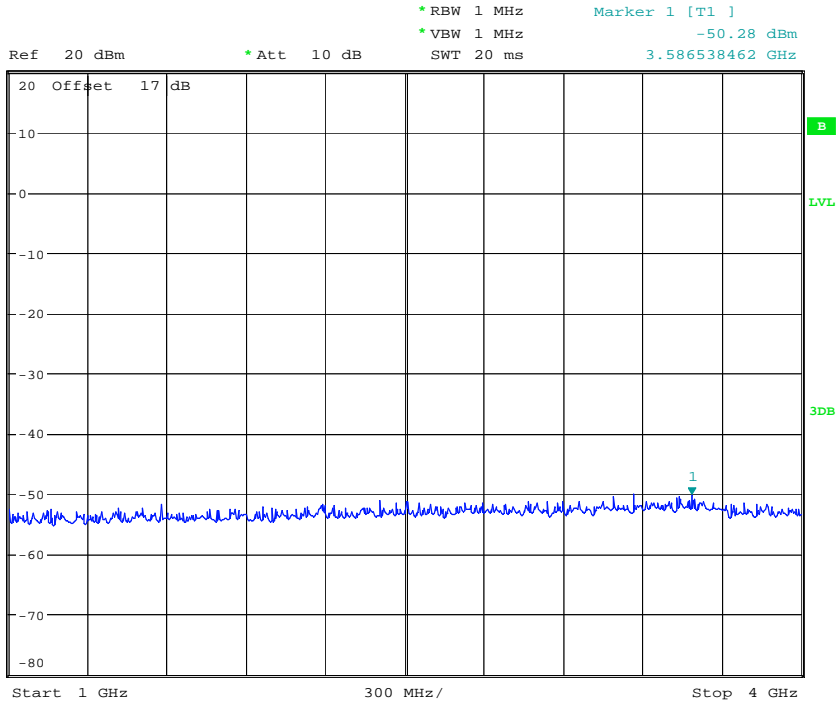

CONDUCTED SPURIOUS EMISSION WCDMA BAND II IDLE

Date: 22.AUG.2013 21:24:29

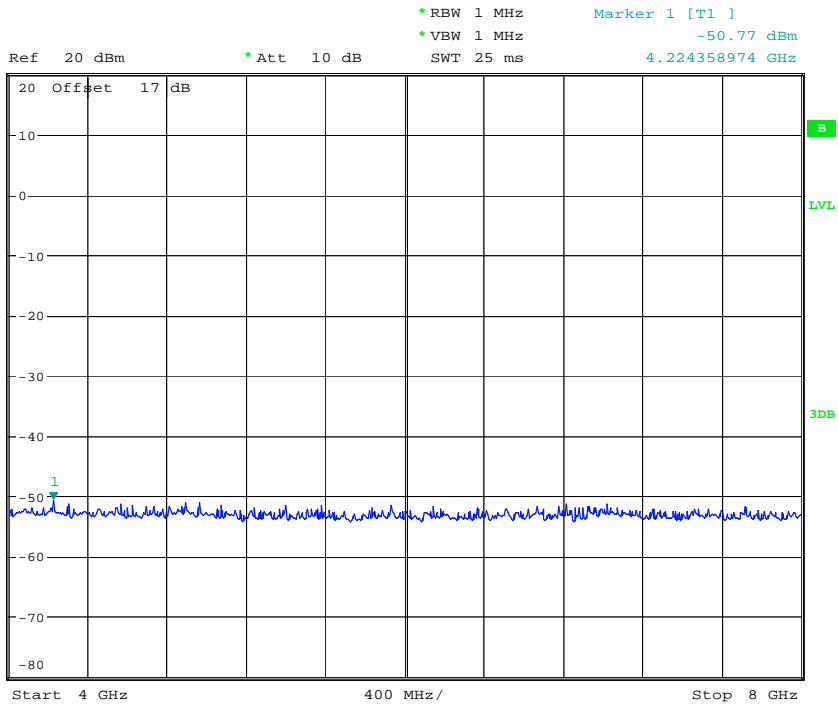

CONDUCTED SPURIOUS EMISSION WCDMA BAND II IDLE

Date: 22.AUG.2013 21:24:50

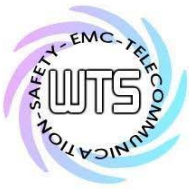

Report Number: W6M21308-13443-P-2224
FCC ID: GX9MX

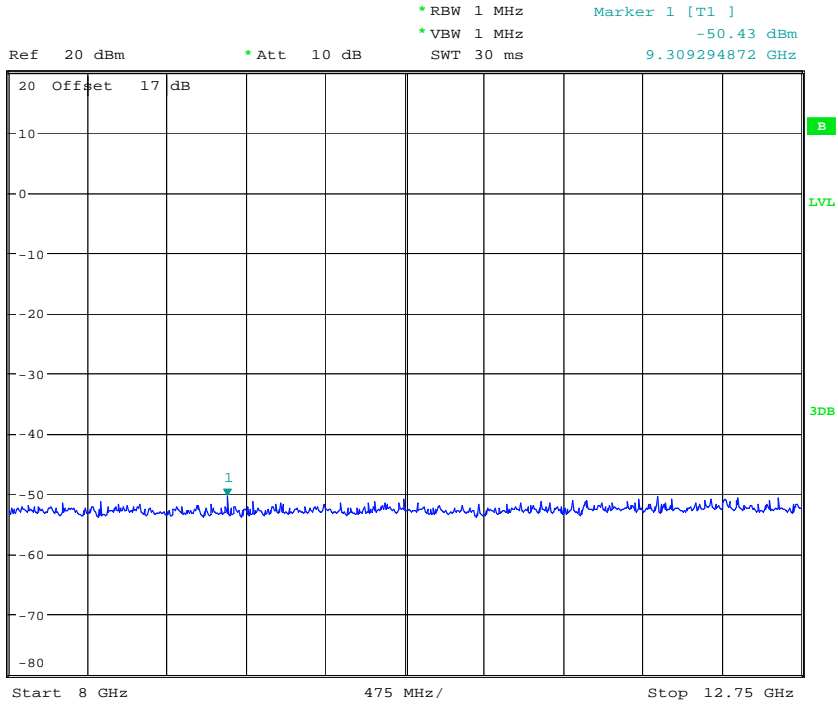

CONDUCTED SPURIOUS EMISSION WCDMA BAND II IDLE

Date: 22.AUG.2013 21:29:16

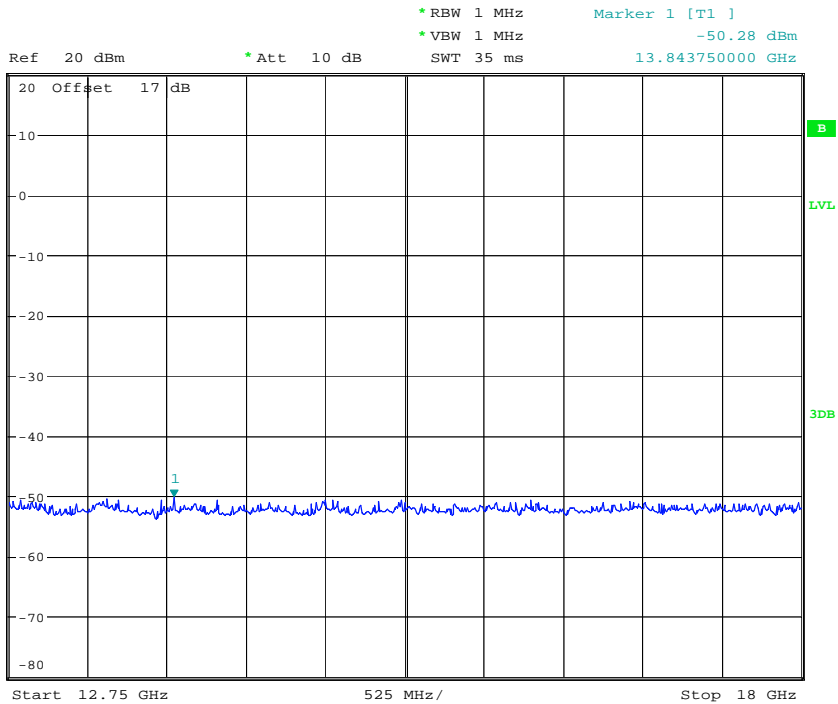

CONDUCTED SPURIOUS EMISSION WCDMA BAND II IDLE

Date: 22.AUG.2013 21:29:41

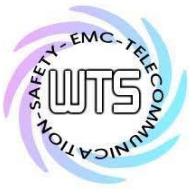

Report Number: W6M21308-13443-P-2224
FCC ID: GX9MX

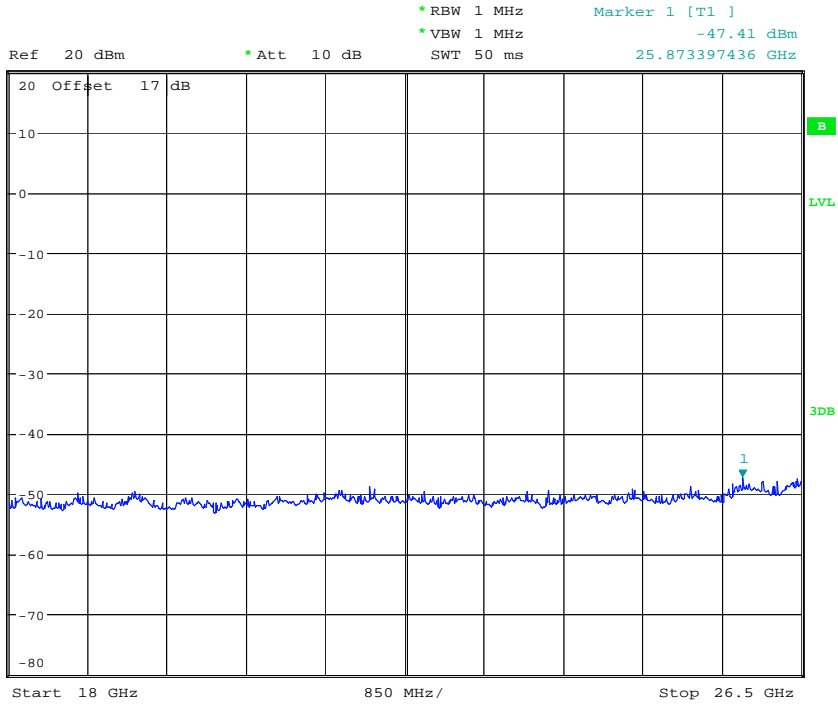

CONDUCTED SPURIOUS EMISSION WCDMA BAND II IDLE

Date: 22.AUG.2013 21:32:21

CH4132

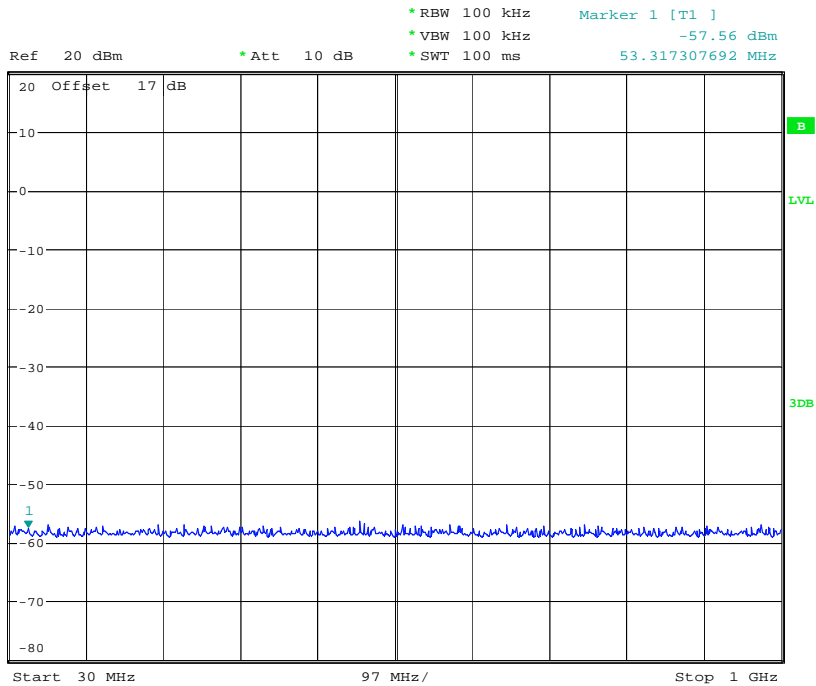

CONDUCTED SPURIOUS EMISSION WCDMA BAND V CH4132

Date: 22.AUG.2013 19:52:35

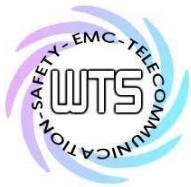

Report Number: W6M21308-13443-P-2224
FCC ID: GX9MX

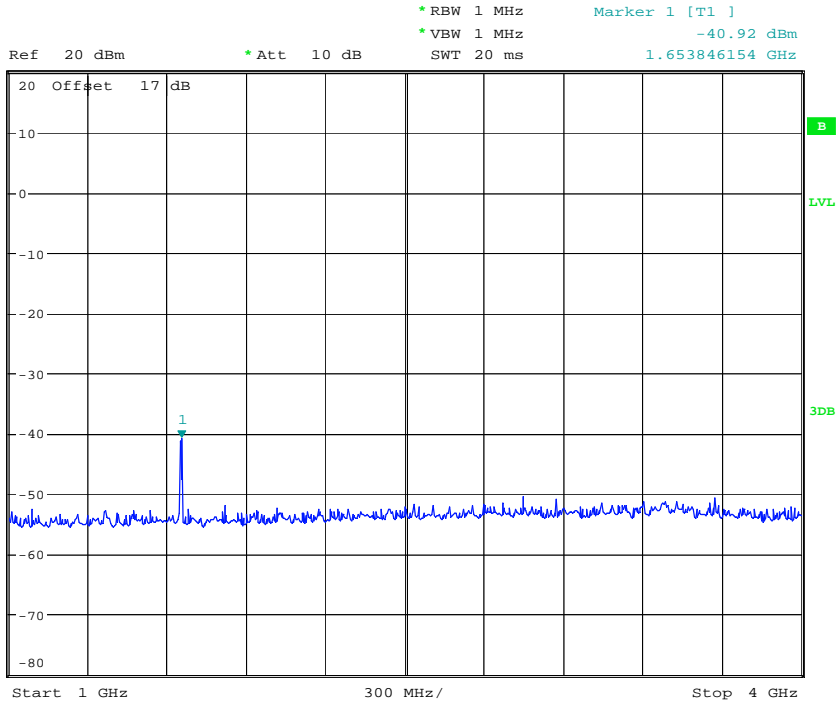

CONDUCTED SPURIOUS EMISSION WCDMA BAND V CH4132

Date: 22.AUG.2013 21:16:31

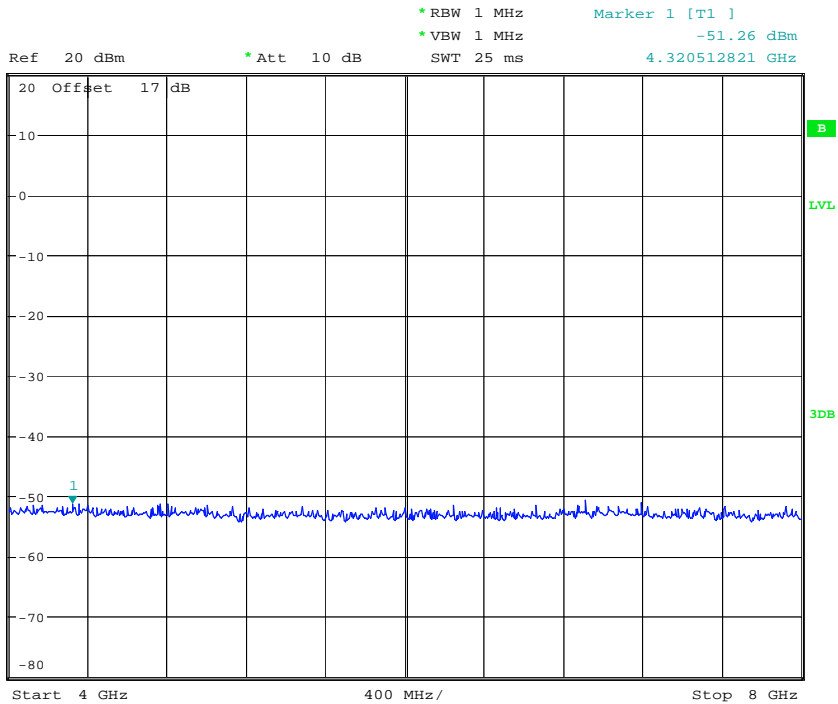

CONDUCTED SPURIOUS EMISSION WCDMA BAND V CH4132

Date: 22.AUG.2013 20:01:33

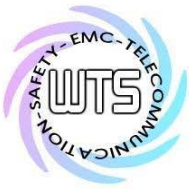

Report Number: W6M21308-13443-P-2224
FCC ID: GX9MX

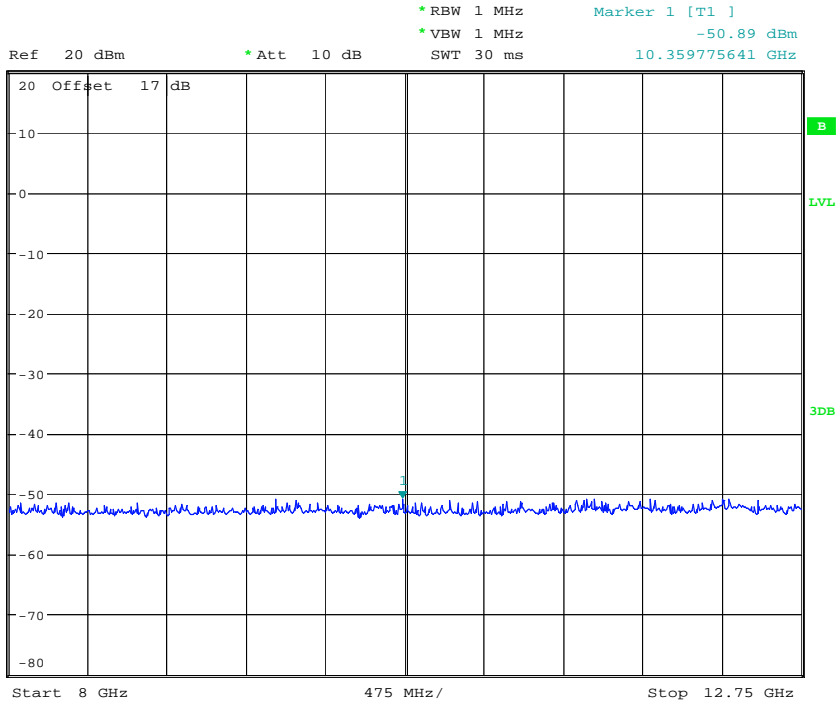

CONDUCTED SPURIOUS EMISSION WCDMA BAND V CH4132

Date: 22.AUG.2013 20:02:51

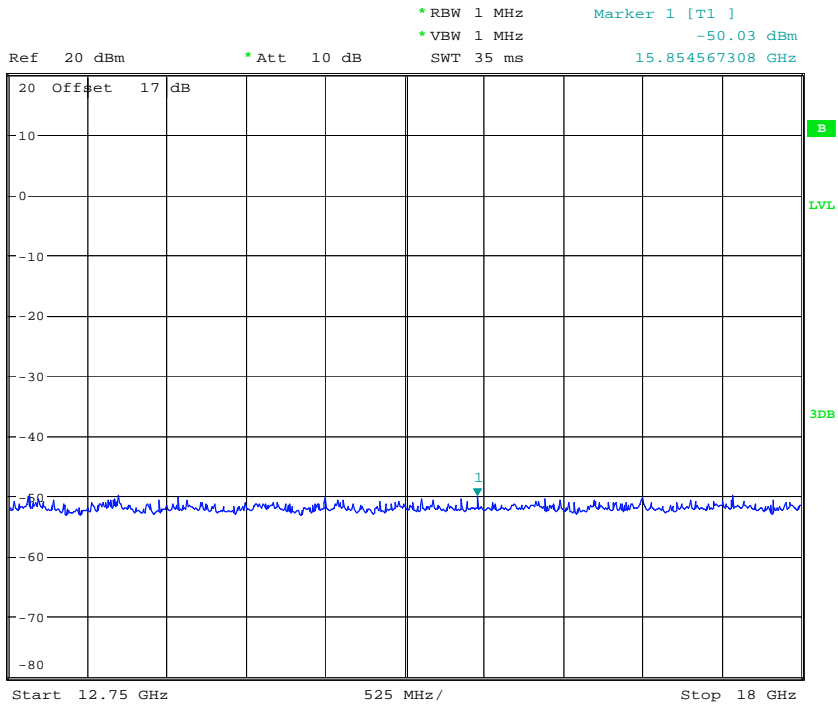

CONDUCTED SPURIOUS EMISSION WCDMA BAND V CH4132

Date: 22.AUG.2013 20:45:40