

**47 CFR PART 15 SUBPART C TEST REPORT**

**for**

**Hybrid Security Alarm System**

**Model No.: HYBx-xxxxx-xxxxx Series**

**(x=0~9, A~Z or blank)**

**FCC ID: GX9HYBLI**

of

Applicant: CLIMAX TECHNOLOGY CO., LTD.

Address: No. 258, Sinhu 2nd Rd., Neihu District, Taipei City 114,  
Taiwan ( R.O.C.)

Tested and Prepared

by

**Worldwide Testing Services (Taiwan) Co., Ltd.**

**FCC Registration No.: TW1072, TW1140, TW1146, TW1477, TW0037**

**Industry Canada filed test laboratory Reg. No.: 20037, 31634**



**Report No.: W6M22410-23833-C-247**

6F, NO. 58, LANE 188, RUEY-KUANG RD., NEIHU TAIPEI 114, TAIWAN, R.O.C.  
TEL: 886-2-66068877 FAX: 886-2-66068879 E-mail: [wts@wts-lab.com](mailto:wts@wts-lab.com)



# Worldwide Testing Services(Taiwan) Co., Ltd.

Registration number: W6M22410-23833-C-247

FCC ID: GX9HYBLI

## Certification of Test Report

Applicant : CLIMAX TECHNOLOGY CO., LTD.  
No. 258, Sinhu 2nd Rd., Neihu District,  
Taipei City 114, Taiwan ( R.O.C.)

Manufacturer : CLIMAX TECHNOLOGY CO., LTD.  
No. 258, Sinhu 2nd Rd., Neihu District,  
Taipei City 114, Taiwan ( R.O.C.)

Tested equipment :

Type description : Hybrid Security Alarm System  
Model number : HYBx-xxxxx-xxxxx Series(x=0~9, A~Z or blank)  
Brand name : ./.  
Operation frequency : Please see chapter 2.3.  
RF output power : Band 2: 24.79dBm (EIRP)  
Band 4 26.19dBm (EIRP)  
Band 5: 21.66dBm (ERP)  
Band 7: 26.49dBm (EIRP)  
Band 40: 25.74dBm (EIRP)  
Power supply : 100-240Va.c.

Regulation applied : 47CFR Part 22 (2023-10), Part 24 (2023-10),  
Part 27 (2023-10)

Test method : 47CFR Part 2 (2023), TIA/EIA-603E (2016) and  
ANSI C63.26 (2015)

I HEREBY CERTIFY THAT: The test results written in this report were derived conscientiously in accordance with the requirements and procedures of 47CFR Part 2 (2023), TIA/EIA-603E (2016), and it was found that the device described above is in compliance with the applicable limits specified in 47CFR Part 22/24/27.

Laboratory disclaimer:

1. The result of this test report is valid only in connection to the sample has been tested at the laboratory of Worldwide Testing Services (Taiwan) Co. Ltd.
2. This test report shall always be duplicated in full pages unless the written approval of the testing laboratory is obtained.
3. Antenna gain is provided by applicant and laboratory issue relevant data and results.



# Worldwide Testing Services(Taiwan) Co., Ltd.

Registration number: W6M22410-23833-C-247

FCC ID: GX9HYBLI

Test engineer:

October 26, 2024

Rick Chen

*Sora*

Date

WTS-Lab.

Name

Signature

Technical responsibility for area of testing:

October 26, 2024

Kevin Wang

*Kevin Wang*

Date

WTS

Name

Signature

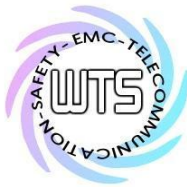

Registration number: W6M22410-23833-C-247

FCC ID: GX9HYBLI

**TABLE OF CONTENTS**

**1. SUMMARY .....3**

1.1 DESCRIPTION OF TESTED EQUIPMENT .....3

1.2 DATE OF TESTING PROCESSING .....3

1.3 MODIFICATION INFORMATION .....3

1.4 TEST STANDARDS .....3

1.5 SUMMARY OF TEST RESULT .....4

**2. GENERAL INFORMATION .....5**

2.1 TESTING LABORATORY .....5

2.2 DETAILS OF APPROVAL HOLDER .....5

2.3 DESCRIPTION OF TESTED SYSTEM .....6

2.4 TEST ENVIRONMENT .....8

2.5 GENERAL TEST REQUIREMENT .....9

2.6 TEST EQUIPMENT LIST .....10

**3. RF POWER OUTPUT .....12**

3.1 TEST PROCEDURE .....12

3.2 TEST RESULTS .....13

**4. MODULATION CHARACTERISTICS .....20**

4.1 TEST PROCEDURE .....20

4.2 TEST RESULTS .....20

**5. PEAK-TO-AVERAGE RATIO .....21**

5.1 TEST PROCEDURE .....21

5.2 TEST SET UP .....21

5.3 TEST RESULTS .....22

**6. OCCUPIED BANDWIDTH .....30**

6.1 TEST PROCEDURE .....30

6.2 TEST RESULTS .....31

**7. SPURIOUS EMISSIONS AT ANTENNA TERMINALS .....52**

7.1 TEST PROCEDURE .....56

7.2 TEST RESULTS .....56

7.3 EXPLANATION OF TEST RESULT .....128

7.4 CALCULATION OF LIMIT FOR SPURIOUS AT ANTENNA TERMINALS .....128

**8. FIELD STRENGTH OF SPURIOUS RADIATION .....129**

8.1 TEST PROCEDURE .....129

8.2 TEST RESULTS .....129

8.3 EXPLANATION OF TEST RESULT .....129

8.4 CALCULATION OF LIMIT FOR FIELD STRENGTH OF SPURIOUS .....129

8.5 TEST RESULT OF BAND EDGE EMISSIONS .....130



# Worldwide Testing Services(Taiwan) Co., Ltd.

Registration number: W6M22410-23833-C-247

FCC ID: GX9HYBLI

<b>9. FREQUENCY STABILITY .....</b>	<b>196</b>
9.1 TEST PROCEDURE.....	203
9.2 TEST RESULTS .....	204
<b>APPENDIX.....</b>	<b>207</b>

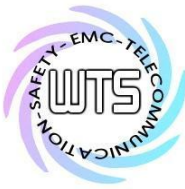

Registration number: W6M22410-23833-C-247

FCC ID: GX9HYBLI

**1 Summary**

**1.1 Description of tested equipment**

This equipment under tested, HYBx-xxxxx-xxxxx Series(x=0~9, A~Z or blank) is a Hybrid Security Alarm System.

This test report only contains test requirements specified in 47CFR Part 22, Part 24, Part 27 for LTE function. For other functions; please refer to separate test report with respect to the relevant test standard and specification.

**1.2 Date of testing processing**

Date of receipt of test item: October 17, 2024

Date of test: from October 18, 2024 to October 25, 2024

Other Information: None

**1.3 Modification Information**

No modification was made during the all test items been performed.

**1.4 Test standards**

Technical standard: **47CFR Part 22 (2023-10), Part 24 (2023-10), Part 27 (2023-10)**

Test method: **47 CFR Part 2 (2021), TIA/EIA-603E (2016), ANSI C63.26 (2015)**

Deviation from test standard: None

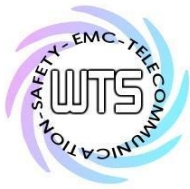

Registration number: W6M22410-23833-C-247

FCC ID: GX9HYBLI

**1.5 Summary of test result**

Harmonized Standard Requirements and Conformance Test Specifications				
Item	Clause	Test Content	Limit	Test Result
3.2	§22.913 §24.232 §27.50	Effective Radiated Power and Equivalent Isotropic Radiated Power Measurement	ERP < 7 Watts (Band 5) EIRP < 2 Watts (Band 2) EIRP < 1 Watts (Band 4)	Pass
5.3	§24.232 §27.50	Peak-to-Average Ratio	< 13 dB	Pass
6.2	§2.1049	Occupied Bandwidth	OBW : No Limit	Pass
7.2	§22.917 §24.238 §27.53	Conducted Spurious Emission Measurement	< 43+10log10(P[Watts])	Pass
8.2	§22.917 §24.238 §27.53	Radiated Spurious Emission Measurement	< 43+10log10(P[Watts])	Pass
8.5	§22.917 §24.238 §27.53	Conducted Band Edge Measurement	< 43+10log10(P[Watts])	Pass
9.2	§2.1055 §22.355 §24.235 §27.54	Frequency stability / Temperature variation Measurement	< 2.5 ppm	Pass

Test item Name	Measurement Uncertainty
Estimation Result of Uncertainty of Radiated Emission(3M-966A)	Expanded Uncertainty : 0.009-30 MHz : 1.88 dB 30-1000 MHz : 3.20 dB 1-18 GHz : 3.56 dB 18-40 GHz : 2.94 dB
Estimation Result of Uncertainty of Conducted Output Power Measurement	Expanded Uncertainty : 1.64 dB
Estimation Result of Uncertainty of Bandwidth Measurement	Expanded Uncertainty : 0.45 kHz
Estimation Result of Uncertainty of Frequency Drift Measurement	Expanded Uncertainty : 6.11 Hz
Estimation Result of Uncertainty of Band Edge Measurement	Expanded Uncertainty : 0.67 dBc

The decision rule is: Measurement uncertainty is not included in the calculation of test results.



Registration number: W6M22410-23833-C-247

FCC ID: GX9HYBLI

## **2 General Information**

### **2.1 Testing laboratory**

#### **2.1.1 Location**

10m OATS

No.5-1, Lishui, Shuang Sing Village, Wanli Dist.,  
New Taipei City 207, Taiwan (R.O.C.)

3 meter semi-anechoic chamber

No. 99, Sec. 1, Balian Rd., Xizhi Dist.,  
New Taipei City 221032, Taiwan (R.O.C.)

Worldwide Testing Services (Taiwan) Co., Ltd.  
6F., No. 58, Ln. 188, Ruiguang Rd., Neihu Dist.,  
Taipei City 114, Taiwan (R.O.C.)  
Tel: 886-2-6606-8877

#### **2.1.2 Details of accreditation status**

Accredited testing laboratory

FCC filed test laboratory Reg. No.: TW1072, TW1140, TW1146, TW1477, TW0037

Industry Canada filed test laboratory Reg. No.: 20037, 31634

#### **2.1.3 Test location, where different from Worldwide Testing Services (Taiwan) Co., Ltd.**

Name: ./.  
Accredited number: ./.  
Street: ./.  
Town: ./.  
Country: ./.

### **2.2 Details of approval holder**

Name: CLIMAX TECHNOLOGY CO., LTD.  
Street: No. 258, Sinhu 2nd Rd., Neihu District,  
Town: Taipei City 114,  
Country: Taiwan ( R.O.C.)

**Manufacturer:** (if different from applicant)

Name: ./.  
Street: ./.  
Town: ./.  
Country: ./.





Registration number: W6M22410-23833-C-247

FCC ID: GX9HYBLI

**2.3 Description of Tested System**

The EUT was tested alone without the Accessories or Peripherals.

Equipment	Model No.	Series No.	Software	Cable information	Note
No accessories were used with this EUT.					

Frequencies Selected to be investigated:

**Band 2**

Test Frequency ID	Bandwidth [MHz]	N <sub>UL</sub>	Frequency of Uplink [MHz]	N <sub>DL</sub>	Frequency of Downlink [MHz]
Low Range	1.4	18607	1850.7	607	1930.7
	3	18615	1851.5	615	1931.5
	5	18625	1852.5	625	1932.5
	10	18650	1855	650	1935
	15 [1]	18675	1857.5	675	1937.5
	20 [1]	18700	1860	700	1940
Mid Range	1.4/3/5/10 15 [1]/20 [1]	18900	1880	900	1960
High Range	1.4	19193	1909.3	1193	1989.3
	3	19185	1908.5	1185	1988.5
	5	19175	1907.5	1175	1987.5
	10	19150	1905	1150	1985
	15 [1]	19125	1902.5	1125	1982.5
	20 [1]	19100	1900	1100	1980
NOTE 1: Bandwidth for which a relaxation of the specified UE receiver sensitivity requirement (TS 36.101 [27] Clause 7.3) is allowed.					

**Band 4**

Test Frequency ID	Bandwidth [MHz]	N <sub>UL</sub>	Frequency of Uplink [MHz]	N <sub>DL</sub>	Frequency of Downlink [MHz]
Low Range	1.4	19957	1710.7	1957	2110.7
	3	19965	1711.5	1965	2111.5
	5	19975	1712.5	1975	2112.5
	10	20000	1715	2000	2115
	15	20025	1717.5	2025	2117.5
	20	20050	1720	2050	2120
Mid Range	1.4/3/5/10/15/20	20175	1732.5	2175	2132.5
High Range	1.4	20393	1754.3	2393	2154.3
	3	20385	1753.5	2385	2153.5
	5	20375	1752.5	2375	2152.5
	10	20350	1750	2350	2150
	15	20325	1747.5	2325	2147.5
	20	20300	1745	2300	2145

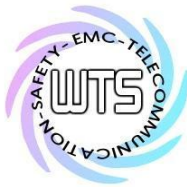

# Worldwide Testing Services(Taiwan) Co., Ltd.

Registration number: W6M22410-23833-C-247

FCC ID: GX9HYBLI

## Band 5

Test Frequency ID	Bandwidth [MHz]	N <sub>UL</sub>	Frequency of Uplink [MHz]	N <sub>DL</sub>	Frequency of Downlink [MHz]
Low Range	1.4	20407	824.7	2407	869.7
	3	20415	825.5	2415	870.5
	5	20425	826.5	2425	871.5
	10 [1]	20450	829	2450	874
Mid Range	1.4/3/5 10 [1]	20525	836.5	2525	881.5
High Range	1.4	20643	848.3	2643	893.3
	3	20635	847.5	2635	892.5
	5	20625	846.5	2625	891.5
	10 [1]	20600	844	2600	889

NOTE 1: Bandwidth for which a relaxation of the specified UE receiver sensitivity requirement (TS 36.101 [27] Clause 7.3) is allowed.

## Band 7

Test Frequency ID	Bandwidth [MHz]	N <sub>UL</sub>	Frequency of Uplink [MHz]	N <sub>DL</sub>	Frequency of Downlink [MHz]
Low Range	5	20775	2502.5	2775	2622.5
	10	20800	2505	2800	2625
	15	20825	2507.5	2825	2627.5
	20 [1]	20850	2510	2850	2630
Mid Range	5/10/15 20 [1]	21100	2535	3100	2655
High Range	5	21425	2567.5	3425	2687.5
	10	21400	2565	3400	2685
	15	21375	2562.5	3375	2682.5
	20 [1]	21350	2560	3350	2680

NOTE 1: Bandwidth for which a relaxation of the specified UE receiver sensitivity requirement (TS 36.101 [27] Clause 7.3) is allowed.

## Band 40

Test Frequency ID	Bandwidth [MHz]	EARFCN	Frequency (UL and DL) [MHz]
Low Range	5	38675	2302.5
	10	38700	2305
	15	38725	2307.5
	20	38750	2310
Mid Range	5/10/15/20	39150	2350
High Range	5	39625	2397.5
	10	39600	2395
	15	39575	2392.5
	20	39550	2390



Registration number: W6M22410-23833-C-247

FCC ID: GX9HYBLI

Antenna type:	Monopole antenna
Antenna gain:	Band 2: 1.37dBi 、 Band 4: 2.61dBi 、 Band 5: -0.61dBi 、 Band 7: 4.55dBi 、 Band 40: 3.23dBi
Power supply:	100-240V a.c.
Sample no.:	#01

## 2.4 Test environment

Temperature:	27 °C
Relative humidity content:	54 %
Air pressure:	86-103 Kpa

### Special statement:

1. This test report is valid in connection to the model has been tested, any modification to the product which is different from the test model will avoid the certification of the test report.
2. This test report shall always be duplicated in full pages unless the written approval of the testing.
3. The x in model number is representing different case shape, case colors, led mask color, and control ID.
4. The model number of EUT is HYB-LITE. This model does not contain logo.

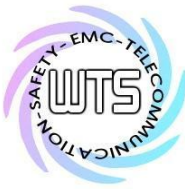

Registration number: W6M22410-23833-C-247

FCC ID: GX9HYBLI

## **2.5 General Test Requirement**

**Radiated Emission:** For investigated frequency is equal to or below 1GHz, the RBW and VBW of the spectrum analyzer was 100 kHz and 100 kHz respectively with an appropriate sweep speed.

For investigated frequency is above 1GHz, both of RBW and VBW of the spectrum analyzer were 1 MHz with an appropriate sweep speed. The analyzer was calibrated in dB above a microvolt at the output of the antenna.

The table used for radiated measurements is capable of continuous rotation. The spectrum was scanned from 30 MHz to the frequency specified as follows:

- (1) If the intentional radiator operates below 10 GHz: to the tenth harmonic of the highest fundamental frequency or to 40 GHz, whichever is lower.
- (2) If the intentional radiator operates at or above 10 GHz and below 30 GHz: to the fifth harmonic of the highest fundamental frequency or to 100 GHz, whichever is lower.
- (3) If the intentional radiator operates at or above 30 GHz: to the fifth harmonic of the highest fundamental frequency or to 200 GHz, whichever is lower, unless specified otherwise elsewhere in the rules.

For hand-held devices, a exploratory test was performed with three (3) orthogonal planes to determine the highest emissions.

When an emission was found, the table was rotated to produce the maximum signal strength. At this point, the antenna was raised and lowered from 1m to 4m. The antenna was placed in both the horizontal and vertical planes.

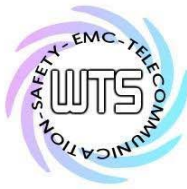

Registration number: W6M22410-23833-C-247

FCC ID: GX9HYBLI

**2.6 Test Equipment List**

**Power**

Code No.	Test equipment	Mode No.	Serial No.	Brand	Cal. Date	Next Cal. Date
ETSTW-RE 050	Attenuator 10dB	50HF-010-1	None	JFW	2024/2/16	2025/2/15
ETSTW-RE 099	DC Block	50DB-007-1	None	JFW	2024/2/16	2025/2/15
ETSTW-GSM 003	Radio Communication Analyzer	MT8820C	6201342073	Anritsu	2024/5/8	2025/5/7
ETSTW-Cable 030	Microwave Cable	SUCOFLEX 104 (S_Cable 9)	279067	HUBER+SUHNER	2024/8/26	2025/8/25

**Frequency stability**

Code No.	Test equipment	Mode No.	Serial No.	Brand	Cal. Date	Next Cal. Date
ETSTW-CE 009	TEMP.& HUMIDITY CHAMBER	GTH-225-40-1P-U	MAA0305-009	GIANT FORCE	2024/7/23	2025/7/22
ETSTW-RE 050	Attenuator 10dB	50HF-010-1	None	JFW	2024/2/16	2025/2/15
ETSTW-RE 099	DC Block	50DB-007-1	None	JFW	2024/2/16	2025/2/15
ETSTW-GSM 003	Radio Communication Analyzer	MT8820C	6201342073	Anritsu	2024/5/8	2025/5/7
ETSTW-Cable 030	Microwave Cable	SUCOFLEX 104 (S_Cable 9)	279067	HUBER+SUHNER	2024/2/16	2025/2/15

**Peak to Average Ratio & Conducted Spurious emission, band edge, Occupied Bandwidth, 26DB Bandwidth**

Code No.	Test equipment	Mode No.	Serial No.	Brand	Cal. Date	Next Cal. Date
ETSTW-RE 050	Attenuator 10dB	50HF-010-1	None	JFW	2024/2/16	2025/2/15
ETSTW-RE 055	SPECTRUM ANALYZER	FSU 26	200074	R&S	2024/3/7	2025/3/6
ETSTW-RE 099	DC Block	50DB-007-1	None	JFW	2024/2/16	2025/2/15
ETSTW-GSM 023	Power Divider	4901.19.A	None	SUHNER	2024/8/26	2025/8/25
ETSTW-GSM 003	Radio Communication Analyzer	MT8820C	6201342073	Anritsu	2024/5/8	2025/5/7
ETSTW-Cable 030	Microwave Cable	SUCOFLEX 104 (S_Cable 9)	279067	HUBER+SUHNER	2024/2/16	2025/2/15

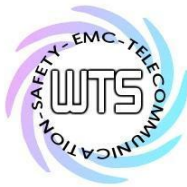

# Worldwide Testing Services(Taiwan) Co., Ltd.

Registration number: W6M22410-23833-C-247

FCC ID: GX9HYBLI

## Spurious Emission (966A)

Code No.	Test equipment	Mode No.	Serial No.	Brand	Cal. Date	Next Cal. Date
ETSTW-RE 153	Signal Analyzer	FSV40	101929	R&S	2024/9/11	2025/9/10
ETSTW-RE 154	EMI Test Receiver	ESR3	102829	R&S	2024/4/10	2025/4/9
ETSTW-RE 160	Amplifier Module	CHC 3	None	WTS	2024/7/12	2025/7/11
ETSTW-RE 177	TRILOG Broadband Antenna	VULB 9168&EMCI-N-6-06	01380&AT-06007	SCHWARZBECK &EMC	2024/3/4	2025/3/3
ETSTW-RE 178	Double Ridged Guide Horn Antenna	DRH18-E	210505A18ES	RFSPIN	2024/2/29	2025/2/28
ETSTW-Cable 077	SMA type cable (10m)	EMC104-SM-SM-10000	230511	EMCI	2024/7/12	2025/7/11
ETSTW-Cable 084	SMA type cable (1m)	SF104-11SMA-1000	816477/4	HONOVA	2024/7/12	2025/7/11
ETSTW-Cable 089	SMA type cable (2m)	SF104-11SMA-2000	SN 811889/4	HUBER+SUHNER	2024/7/12	2025/7/11
WTSTW-SW 002	EMI TEST SOFTWARE	EZ_EMC	None	Farad	Version ETS-03A1 Version EMEC-3A1+	
ETSTW-GSM 024	Radio Communication Analyzer	MT8821C	None	Anritsu	2024/4/23	2025/4/22

Registration number: W6M22410-23833-C-247

FCC ID: GX9HYBLI

### 3. RF Power Output

#### 3.1 Test procedure

##### 3.1.1 Conducted Method

Per 47CFR Part 2.1046, the RF power output shall be measured at the RF output terminals and following procedure is employed:

The transmitter output was connected as the following figure:

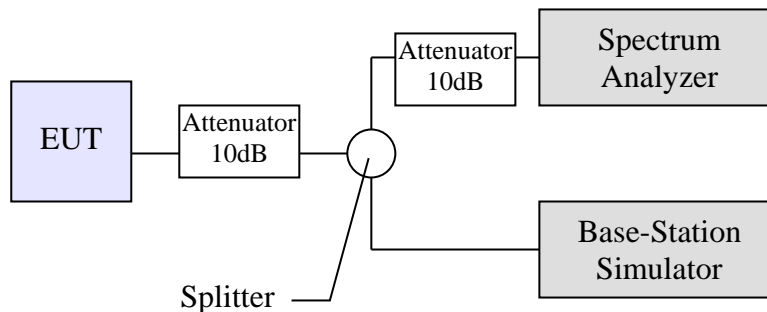

The whole connection system is calibrated with a standard signal generator. Power on and make a link form simulator to EUT and then set the EUT to maximum output power.

Measure the RF power with the spectrum analyzer in accordance the following settings:

RBW: 300 kHz for Frequency below 1GHz and 1MHz for Frequency equal to and above 1GHz.

VBW: 300 kHz for Frequency below 1GHz and 1MHz for Frequency equal to and above 1GHz.

Span: 2MHz

Sweep: 3s

The power output at the transmitter antenna terminal is then determined by assign the value of the corrected factor to the spectrum analyzer reading.

Tests were performed at three frequencies (low, middle and high channels) and operation mode selected.



# Worldwide Testing Services(Taiwan) Co., Ltd.

Registration number: W6M22410-23833-C-247

FCC ID: GX9HYBLI

## 3.2 Test Results

Test date: October 20, 2024

Temperature: 25.5 °C

Humidity: 58.9 %

Tester: Sora

### Band 2

BW(MHz)	Modulation	RB Size	RB offset	POWER(dBm)	POWER(dBm)	POWER(dBm)	EIRP	EIRP	EIRP
				Low Ch18607/1850.7MHz	Mid Ch18900/1880MHz	High Ch19193/1909.3MHz	Low Ch18607/1850.7MHz	Mid Ch18900/1880MHz	High Ch19193/1909.3MHz
1.4	QPSK	1	0	22.59	22.67	22.53	23.96204	24.04204	23.90204
1.4	QPSK	1	3	23.14	22.87	22.68	24.51204	24.24204	24.05204
1.4	QPSK	1	5	22.71	22.73	22.48	24.08204	24.10204	23.85204
1.4	QPSK	3	0	23.04	23.01	22.86	24.41204	24.38204	24.23204
1.4	QPSK	3	1	22.98	23	22.84	24.35204	24.37204	24.21204
1.4	QPSK	3	3	22.94	22.81	22.74	24.31204	24.18204	24.11204
1.4	QPSK	6	0	21.79	21.97	21.76	23.16204	23.34204	23.13204
1.4	16QAM	1	0	21.29	21.79	21.22	22.66204	23.16204	22.59204
1.4	16QAM	1	3	22.23	21.76	21.73	23.60204	23.13204	23.10204
1.4	16QAM	1	5	22.02	21.97	21.54	23.39204	23.34204	22.91204
BW(MHz)	Modulation	RB Size	RB offset	POWER(dBm)	POWER(dBm)	POWER(dBm)	EIRP	EIRP	EIRP
				Low Ch18615/1851.5MHz	Mid Ch18900/1880MHz	High Ch19185/1908.5MHz	Low Ch18615/1851.5MHz	Mid Ch18900/1880MHz	High Ch19185/1908.5MHz
3	QPSK	1	0	22.83	23.03	22.85	24.20204	24.40204	24.22204
3	QPSK	1	7	22.82	22.85	22.78	24.19204	24.22204	24.15204
3	QPSK	1	14	22.74	22.88	22.61	24.11204	24.25204	23.98204
3	QPSK	8	0	21.89	21.95	21.89	23.26204	23.32204	23.26204
3	QPSK	8	3	21.87	21.96	21.77	23.24204	23.33204	23.14204
3	QPSK	8	7	21.87	21.92	21.68	23.24204	23.29204	23.05204
3	QPSK	15	0	21.89	22.07	21.91	23.26204	23.44204	23.28204
3	16QAM	1	0	21.84	21.76	21.74	23.21204	23.13204	23.11204
3	16QAM	1	7	22.33	22.3	21.64	23.70204	23.67204	23.01204
3	16QAM	1	14	21.66	21.87	21.69	23.03204	23.24204	23.06204
BW(MHz)	Modulation	RB Size	RB offset	POWER(dBm)	POWER(dBm)	POWER(dBm)	EIRP	EIRP	EIRP
				Low Ch18625/1852.5MHz	Mid Ch18900/1880MHz	High Ch19175/1907.5MHz	Low Ch18625/1852.5MHz	Mid Ch18900/1880MHz	High Ch19175/1907.5MHz
5	QPSK	1	0	22.64	22.74	22.73	24.01204	24.11204	24.10204
5	QPSK	1	12	22.74	22.91	22.8	24.11204	24.28204	24.17204
5	QPSK	1	24	22.86	22.91	22.66	24.23204	24.28204	24.03204
5	QPSK	12	0	21.66	21.77	21.54	23.03204	23.14204	22.91204
5	QPSK	12	6	21.71	21.82	21.54	23.08204	23.19204	22.91204
5	QPSK	12	13	21.97	21.72	21.55	23.34204	23.09204	22.92204
5	QPSK	25	0	21.79	21.84	21.64	23.16204	23.21204	23.01204
5	16QAM	1	0	21.22	21.66	21.64	22.59204	23.03204	23.01204
5	16QAM	1	12	22.38	22.27	21.16	23.75204	23.64204	22.53204
5	16QAM	1	24	21.47	21.55	21.38	22.84204	22.92204	22.75204





# Worldwide Testing Services(Taiwan) Co., Ltd.

Registration number: W6M22410-23833-C-247

FCC ID: GX9HYBLI

BW(MHz)	Modulation	RB Size	RB offset	POWER(dBm)	POWER(dBm)	POWER(dBm)	EIRP	EIRP	EIRP
				Low Ch18650/1855MHz	Mid Ch18900/1880MHz	High Ch19150/1905MHz	Low Ch18650/1855MHz	Mid Ch18900/1880MHz	High Ch19150/1905MHz
10	QPSK	1	0	22.72	22.77	22.84	24.09204	24.14204	24.21204
10	QPSK	1	24	22.99	22.82	23.16	24.36204	24.19204	24.53204
10	QPSK	1	49	22.72	22.67	22.62	24.09204	24.04204	23.99204
10	QPSK	25	0	21.91	21.97	22.03	23.28204	23.34204	23.40204
10	QPSK	25	12	21.96	21.89	22.04	23.33204	23.26204	23.41204
10	QPSK	25	25	21.93	21.818	21.77	23.30204	23.19004	23.14204
10	QPSK	50	0	22.01	22.07	21.97	23.38204	23.44204	23.34204
10	16QAM	1	0	21.35	21.48	21.83	22.72204	22.85204	23.20204
10	16QAM	1	24	21.55	22.19	22.01	22.92204	23.56204	23.38204
10	16QAM	1	49	22.13	21.91	21.57	23.50204	23.28204	22.94204
BW(MHz)	Modulation	RB Size	RB offset	POWER(dBm)	POWER(dBm)	POWER(dBm)	EIRP	EIRP	EIRP
				Low Ch18675/1857.5MHz	Mid Ch18900/1880MHz	High Ch19125/1902.5MHz	Low Ch18675/1857.5MHz	Mid Ch18900/1880MHz	High Ch19125/1902.5MHz
15	QPSK	1	0	23.05	23.13	22.84	24.42204	24.50204	24.21204
15	QPSK	1	37	23.26	23.21	23.42	24.63204	24.58204	24.79204
15	QPSK	1	74	23.35	22.99	22.68	24.72204	24.36204	24.05204
15	QPSK	36	0	22.04	22.22	22.01	23.41204	23.59204	23.38204
15	QPSK	36	19	22.33	22.13	22.23	23.70204	23.50204	23.60204
15	QPSK	36	39	22.2	22.11	22.04	23.57204	23.48204	23.41204
15	QPSK	75	0	22.09	22.01	22.02	23.46204	23.38204	23.39204
15	16QAM	1	0	22.13	22.43	22.14	23.50204	23.80204	23.51204
15	16QAM	1	37	22.58	22.62	22.53	23.95204	23.99204	23.90204
15	16QAM	1	74	22.03	22.11	21.77	23.40204	23.48204	23.14204
BW(MHz)	Modulation	RB Size	RB offset	POWER(dBm)	POWER(dBm)	POWER(dBm)	EIRP	EIRP	EIRP
				Low Ch18700/1860MHz	Mid Ch18900/1880MHz	High Ch19100/1900MHz	Low Ch18675/1857.5MHz	Mid Ch18900/1880MHz	High Ch19125/1902.5MHz
20	QPSK	1	0	22.67	22.78	22.49	24.04204	24.15204	23.86204
20	QPSK	1	49	22.84	23.05	23.07	24.21204	24.42204	24.44204
20	QPSK	1	99	23.05	22.65	22.55	24.42204	24.02204	23.92204
20	QPSK	50	0	21.84	21.8	21.72	23.21204	23.17204	23.09204
20	QPSK	50	25	21.81	21.87	21.76	23.18204	23.24204	23.13204
20	QPSK	50	50	21.77	21.79	21.53	23.14204	23.16204	22.90204
20	QPSK	100	0	21.95	22.02	21.69	23.32204	23.39204	23.06204
20	16QAM	1	0	22.16	22.22	21.65	23.53204	23.59204	23.02204
20	16QAM	1	49	22.31	22.29	22.11	23.68204	23.66204	23.48204
20	16QAM	1	99	21.84	22.1	21.74	23.21204	23.47204	23.11204

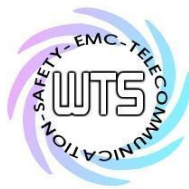

# Worldwide Testing Services(Taiwan) Co., Ltd.

Registration number: W6M22410-23833-C-247

FCC ID: GX9HYBLI

## Band 4

BW(MHz)	Modulation	RB Size	RB offset	POWER(dBm)	POWER(dBm)	POWER(dBm)	EIRP	EIRP	EIRP
				Low Ch19957/1710.7MHz	Mid Ch20175/1732.5MHz	High Ch20393/1754.3MHz	Low Ch19957/1710.7MHz	Mid Ch20175/1732.5MHz	High Ch20393/1754.3MHz
1.4	QPSK	1	0	23	23.01	23.09	25.61054	25.62054	25.70054
1.4	QPSK	1	3	23.15	23.24	23.21	25.76054	25.85054	25.82054
1.4	QPSK	1	5	23.01	23.08	22.99	25.62054	25.69054	25.60054
1.4	QPSK	3	0	23.16	23.37	22.98	25.77054	25.98054	25.59054
1.4	QPSK	3	1	23.13	23.26	23.22	25.74054	25.87054	25.83054
1.4	QPSK	3	3	23.11	23.33	23.12	25.72054	25.94054	25.73054
1.4	QPSK	6	0	22.02	22.15	22.21	24.63054	24.76054	24.82054
1.4	16QAM	1	0	21.47	21.61	21.88	24.08054	24.22054	24.49054
1.4	16QAM	1	3	22.26	22.16	22.31	24.87054	24.77054	24.92054
1.4	16QAM	1	5	22.16	22.12	22.11	24.77054	24.73054	24.72054
BW(MHz)	Modulation	RB Size	RB offset	POWER(dBm)	POWER(dBm)	POWER(dBm)	EIRP	EIRP	EIRP
				Low Ch19965/1711.5MHz	Mid Ch20175/1732.5MHz	High Ch20385/1753.5MHz	Low Ch19965/1711.5MHz	Mid Ch20175/1732.5MHz	High Ch20385/1753.5MHz
3	QPSK	1	0	22.84	23.01	23.05	25.45054	25.62054	25.66054
3	QPSK	1	7	23.34	23.51	23.26	25.95054	26.12054	25.87054
3	QPSK	1	14	23.27	23.05	23.01	25.88054	25.66054	25.62054
3	QPSK	8	0	22.15	22.36	21.91	24.76054	24.97054	24.52054
3	QPSK	8	3	22.11	22.19	21.79	24.72054	24.80054	24.40054
3	QPSK	8	7	22.15	22.18	21.92	24.76054	24.79054	24.53054
3	QPSK	15	0	21.87	22.04	21.65	24.48054	24.65054	24.26054
3	16QAM	1	0	21.81	21.93	21.76	24.42054	24.54054	24.37054
3	16QAM	1	7	21.91	22.03	22.06	24.52054	24.64054	24.67054
3	16QAM	1	14	21.93	21.91	21.59	24.54054	24.52054	24.20054
BW(MHz)	Modulation	RB Size	RB offset	POWER(dBm)	POWER(dBm)	POWER(dBm)	EIRP	EIRP	EIRP
				Low Ch19975/1712.5MHz	Mid Ch20175/1732.5MHz	High Ch20375/1752.5MHz	Low Ch19975/1712.5MHz	Mid Ch20175/1732.5MHz	High Ch20375/1752.5MHz
5	QPSK	1	0	23.12	23.18	23.21	25.73054	25.79054	25.82054
5	QPSK	1	12	23.58	23.28	23.07	26.19054	25.89054	25.68054
5	QPSK	1	24	23.08	23.27	23.01	25.69054	25.88054	25.62054
5	QPSK	12	0	21.99	22.18	21.84	24.60054	24.79054	24.45054
5	QPSK	12	6	22.04	22.13	21.76	24.65054	24.74054	24.37054
5	QPSK	12	13	22.08	22.08	21.75	24.69054	24.69054	24.36054
5	QPSK	25	0	22.27	22.37	22.11	24.88054	24.98054	24.72054
5	16QAM	1	0	21.92	21.96	21.57	24.53054	24.57054	24.18054
5	16QAM	1	12	22.17	22.01	22.33	24.78054	24.62054	24.94054
5	16QAM	1	24	21.84	21.84	22.08	24.45054	24.45054	24.69054

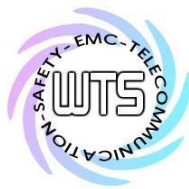

# Worldwide Testing Services(Taiwan) Co., Ltd.

Registration number: W6M22410-23833-C-247

FCC ID: GX9HYBLI

BW(MHz)	Modulation	RB Size	RB offset	POWER(dBm) Low Ch20000/1715MHz	POWER(dBm) Mid Ch20175/1732.5MHz	POWER(dBm) High Ch20350/1750MHz	EIRP Low Ch20000/1715MHz	EIRP Mid Ch20175/1732.5MHz	EIRP High Ch20350/1750MHz
10	QPSK	1	0	23.02	23.19	23.02	25.63054	25.80054	25.63054
10	QPSK	1	24	23.18	23.11	23.17	25.79054	25.72054	25.78054
10	QPSK	1	49	22.94	22.83	22.89	25.55054	25.44054	25.50054
10	QPSK	25	0	22.02	22.16	22.11	24.63054	24.77054	24.72054
10	QPSK	25	12	21.99	22.06	21.96	24.60054	24.67054	24.57054
10	QPSK	25	25	21.95	22.12	21.74	24.56054	24.73054	24.35054
10	QPSK	50	0	22.05	22.11	22.12	24.66054	24.72054	24.73054
10	16QAM	1	0	21.44	21.56	21.87	24.05054	24.17054	24.48054
10	16QAM	1	24	21.68	21.74	21.93	24.29054	24.35054	24.54054
10	16QAM	1	49	21.91	21.53	21.51	24.52054	24.14054	24.12054
BW(MHz)	Modulation	RB Size	RB offset	POWER(dBm) Low Ch20025/1717.5MHz	POWER(dBm) Mid Ch20175/1732.5MHz	POWER(dBm) High Ch20325/1747.5MHz	EIRP Low Ch20025/1717.5MHz	EIRP Mid Ch20175/1732.5MHz	EIRP High Ch20325/1747.5MHz
15	QPSK	1	0	22.94	22.98	23.09	25.55054	25.59054	25.70054
15	QPSK	1	37	23.44	23.36	23.38	26.05054	25.97054	25.99054
15	QPSK	1	74	23.03	23.12	23.12	25.64054	25.73054	25.73054
15	QPSK	36	0	22.16	22.29	22.09	24.77054	24.90054	24.70054
15	QPSK	36	19	22.09	22.19	22.12	24.70054	24.80054	24.73054
15	QPSK	36	39	22.13	22.27	22.09	24.74054	24.88054	24.70054
15	QPSK	75	0	22.26	22.31	22.14	24.87054	24.92054	24.75054
15	16QAM	1	0	22.11	22.27	22.37	24.72054	24.88054	24.98054
15	16QAM	1	37	22.51	22.27	22.55	25.12054	24.88054	25.16054
15	16QAM	1	74	22.23	22.22	22.37	24.84054	24.83054	24.98054
BW(MHz)	Modulation	RB Size	RB offset	POWER(dBm) Low Ch20050/1720MHz	POWER(dBm) Mid Ch20175/1732.5MHz	POWER(dBm) High Ch20300/1745MHz	EIRP Low Ch20050/1720MHz	EIRP Mid Ch20175/1732.5MHz	EIRP High Ch20300/1745MHz
20	QPSK	1	0	23.11	23.55	23.34	25.72054	26.16054	25.95054
20	QPSK	1	49	23.26	23.26	23.42	25.87054	25.87054	26.03054
20	QPSK	1	99	23.16	23.11	22.92	25.77054	25.72054	25.53054
20	QPSK	50	0	22.29	22.36	22.42	24.90054	24.97054	25.03054
20	QPSK	50	25	22.55	22.39	22.34	25.16054	25.00054	24.95054
20	QPSK	50	50	22.16	22.26	22.29	24.77054	24.87054	24.90054
20	QPSK	100	0	22.25	22.25	22.22	24.86054	24.86054	24.83054
20	16QAM	1	0	21.88	22.34	22.15	24.49054	24.95054	24.76054
20	16QAM	1	49	22.54	21.94	22.11	25.15054	24.55054	24.72054
20	16QAM	1	99	21.84	22.08	22.1	24.45054	24.69054	24.71054

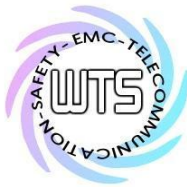

# Worldwide Testing Services(Taiwan) Co., Ltd.

Registration number: W6M22410-23833-C-247

FCC ID: GX9HYBLI

## Band 5

BW(MHz)	Modulation	RB Size	RB offset	POWER(dBm)	POWER(dBm)	POWER(dBm)	ERP	ERP	ERP
				Low Ch20407/824.7MHz	Mid Ch20525/836.5MHz	High Ch20643/848.3MHz	Low Ch20407/824.7MHz	Mid Ch20525/836.5MHz	High Ch20643/848.3MHz
1.4	QPSK	1	0	23.67	23.81	24.16	20.91476	21.05476	21.40476
1.4	QPSK	1	3	23.79	23.98	24.24	21.03476	21.22476	21.48476
1.4	QPSK	1	5	23.76	24.05	23.96	21.00476	21.29476	21.20476
1.4	QPSK	3	0	23.95	24.09	24.11	21.19476	21.33476	21.35476
1.4	QPSK	3	1	24.16	24.14	24.28	21.40476	21.38476	21.52476
1.4	QPSK	3	3	23.79	23.86	24.11	21.03476	21.10476	21.35476
1.4	QPSK	6	0	22.81	22.65	22.93	20.05476	19.89476	20.17476
1.4	16QAM	1	0	22.62	22.86	22.56	19.86476	20.10476	19.80476
1.4	16QAM	1	3	22.92	22.77	23.03	20.16476	20.01476	20.27476
1.4	16QAM	1	5	22.75	22.58	22.86	19.99476	19.82476	20.10476
BW(MHz)	Modulation	RB Size	RB offset	POWER(dBm)	POWER(dBm)	POWER(dBm)	ERP	ERP	ERP
				Low Ch20415/825.5MHz	Mid Ch20525/836.5MHz	High Ch20635/847.5MHz	Low Ch20415/825.5MHz	Mid Ch20525/836.5MHz	High Ch20635/847.5MHz
3	QPSK	1	0	24.16	24.18	24.22	21.40476	21.42476	21.46476
3	QPSK	1	7	24.13	24.13	24.26	21.37476	21.37476	21.50476
3	QPSK	1	14	24.18	24.16	24.21	21.42476	21.40476	21.45476
3	QPSK	8	0	23.06	23.22	23.16	20.30476	20.46476	20.40476
3	QPSK	8	3	23.09	23.09	23.15	20.33476	20.33476	20.39476
3	QPSK	8	7	23.05	23.12	23.26	20.29476	20.36476	20.50476
3	QPSK	15	0	23.04	22.75	23.01	20.28476	19.99476	20.25476
3	16QAM	1	0	22.72	22.69	22.71	19.96476	19.93476	19.95476
3	16QAM	1	7	23.41	23.36	23.02	20.65476	20.60476	20.26476
3	16QAM	1	14	23.19	22.98	23.01	20.43476	20.22476	20.25476
BW(MHz)	Modulation	RB Size	RB offset	POWER(dBm)	POWER(dBm)	POWER(dBm)	ERP	ERP	ERP
				Low Ch20425/826.5MHz	Mid Ch20525/836.5MHz	High Ch20625/846.5MHz	Low Ch20425/826.5MHz	Mid Ch20525/836.5MHz	High Ch20625/846.5MHz
5	QPSK	1	0	23.98	24.05	23.89	21.22476	21.29476	21.13476
5	QPSK	1	12	24.25	24.11	24.38	21.49476	21.35476	21.62476
5	QPSK	1	24	24.25	23.96	24.19	21.49476	21.20476	21.43476
5	QPSK	12	0	23.01	23.07	23.02	20.25476	20.31476	20.26476
5	QPSK	12	6	23.03	23.09	23.11	20.27476	20.33476	20.35476
5	QPSK	12	13	23.01	23.16	23.17	20.25476	20.40476	20.41476
5	QPSK	25	0	22.97	23.01	22.97	20.21476	20.25476	20.21476
5	16QAM	1	0	22.86	22.37	22.82	20.10476	19.61476	20.06476
5	16QAM	1	12	23.6	23.17	22.84	20.84476	20.41476	20.08476
5	16QAM	1	24	22.97	22.95	22.97	20.21476	20.19476	20.21476
BW(MHz)	Modulation	RB Size	RB offset	POWER(dBm)	POWER(dBm)	POWER(dBm)	ERP	ERP	ERP
				Low Ch20450/829MHz	Mid Ch20525/836.5MHz	High Ch20600/844MHz	Low Ch20450/829MHz	Mid Ch20525/836.5MHz	High Ch20600/844MHz
10	QPSK	1	0	23.75	24.11	23.85	20.99476	21.35476	21.09476
10	QPSK	1	24	24.42	24.16	24.24	21.66476	21.40476	21.48476
10	QPSK	1	49	24.08	24.01	24.17	21.32476	21.25476	21.41476
10	QPSK	25	0	23.11	23.11	23.06	20.35476	20.35476	20.30476
10	QPSK	25	12	23.17	23.11	23.05	20.41476	20.35476	20.29476
10	QPSK	25	25	23.22	23.07	23.11	20.46476	20.31476	20.35476
10	QPSK	50	0	23.02	23.12	23	20.26476	20.36476	20.24476
10	16QAM	1	0	22.54	22.96	22.98	19.78476	20.20476	20.22476
10	16QAM	1	24	22.99	22.91	22.97	20.23476	20.15476	20.21476
10	16QAM	1	49	22.66	22.93	22.76	19.90476	20.17476	20.00476



# Worldwide Testing Services(Taiwan) Co., Ltd.

Registration number: W6M22410-23833-C-247

FCC ID: GX9HYBLI

Band 7

BW(MHz)	Modulation	RB Size	RB offset	POWER(dBm)	POWER(dBm)	POWER(dBm)	EIRP	EIRP	EIRP
				Low Ch20775/2502.5MHz	Mid Ch21100/2535MHz	High Ch21425/2567.5MHz	Low Ch20775/2502.5MHz	Mid Ch21100/2535MHz	High Ch21425/2567.5MHz
5	QPSK	1	0	21.74	21.15	21.05	26.28746	25.69746	25.59746
5	QPSK	1	12	21.55	21.43	21.25	26.09746	25.97746	25.79746
5	QPSK	1	24	21.42	21.42	21.08	25.96746	25.96746	25.62746
5	QPSK	12	0	20.55	20.22	20.03	25.09746	24.76746	24.57746
5	QPSK	12	6	20.51	20.38	20.12	25.05746	24.92746	24.66746
5	QPSK	12	13	20.48	20.32	20.16	25.02746	24.86746	24.70746
5	QPSK	25	0	20.59	20.37	20.01	25.13746	24.91746	24.55746
5	16QAM	1	0	20.73	20.04	20.15	25.27746	24.58746	24.69746
5	16QAM	1	12	21.04	20.84	20.35	25.58746	25.38746	24.89746
5	16QAM	1	24	20.61	20.19	20.01	25.15746	24.73746	24.55746
BW(MHz)	Modulation	RB Size	RB offset	POWER(dBm)	POWER(dBm)	POWER(dBm)	EIRP	EIRP	EIRP
				Low Ch20800/2505MHz	Mid Ch21100/2535MHz	High Ch21400/2565MHz	Low Ch20800/2505MHz	Mid Ch21100/2535MHz	High Ch21400/2565MHz
10	QPSK	1	0	21.55	21.16	21.28	26.09746	25.70746	25.82746
10	QPSK	1	24	21.43	21.41	21.55	25.97746	25.95746	26.09746
10	QPSK	1	49	21.33	21.17	21.15	25.87746	25.71746	25.69746
10	QPSK	25	0	20.55	20.17	20.25	25.09746	24.71746	24.79746
10	QPSK	25	12	20.55	20.36	20.07	25.09746	24.90746	24.61746
10	QPSK	25	25	20.33	20.36	20.01	24.87746	24.90746	24.55746
10	QPSK	50	0	20.58	20.32	20.18	25.12746	24.86746	24.72746
10	16QAM	1	0	20.77	20.24	20.01	25.31746	24.78746	24.55746
10	16QAM	1	24	20.55	20.32	20.04	25.09746	24.86746	24.58746
10	16QAM	1	49	20.00	20.25	20.25	24.54746	24.79746	24.79746
BW(MHz)	Modulation	RB Size	RB offset	POWER(dBm)	POWER(dBm)	POWER(dBm)	EIRP	EIRP	EIRP
				Low Ch20825/2507.5MHz	Mid Ch21100/2535MHz	High Ch21375/2562.5MHz	Low Ch20825/2507.5MHz	Mid Ch21100/2535MHz	High Ch21375/2562.5MHz
15	QPSK	1	0	21.65	21.05	21.33	26.19746	25.59746	25.87746
15	QPSK	1	37	21.69	21.52	21.47	26.23746	26.06746	26.01746
15	QPSK	1	74	20.93	21.44	21.19	25.47746	25.98746	25.73746
15	QPSK	36	0	20.55	20.05	20.39	25.09746	24.59746	24.93746
15	QPSK	36	19	20.31	20.23	20.49	24.85746	24.77746	25.03746
15	QPSK	36	39	20.07	20.09	20.05	24.61746	24.63746	24.59746
15	QPSK	75	0	20.19	20.31	20.23	24.73746	24.85746	24.77746
15	16QAM	1	0	20.85	20.24	20.11	25.39746	24.78746	24.65746
15	16QAM	1	37	20.54	20.84	20.46	25.08746	25.38746	25.00746
15	16QAM	1	74	20.17	20.47	20.26	24.71746	25.01746	24.80746
BW(MHz)	Modulation	RB Size	RB offset	POWER(dBm)	POWER(dBm)	POWER(dBm)	EIRP	EIRP	EIRP
				Low Ch20850/2510MHz	Mid Ch21100/2535MHz	High Ch21350/2560MHz	Low Ch20850/2510MHz	Mid Ch21100/2535MHz	High Ch21350/2560MHz
20	QPSK	1	0	21.89	20.97	21.53	26.43746	25.51746	26.07746
20	QPSK	1	49	21.22	21.69	21.48	25.76746	26.23746	26.02746
20	QPSK	1	99	21.05	21.94	21.58	25.59746	26.48746	26.12746
20	QPSK	50	0	20.35	20.04	20.35	24.89746	24.58746	24.89746
20	QPSK	50	25	20.18	20.21	20.27	24.72746	24.75746	24.81746
20	QPSK	50	50	20.07	20.39	20.23	24.61746	24.93746	24.77746
20	QPSK	100	0	20.27	20.31	20.42	24.81746	24.85746	24.96746
20	16QAM	1	0	20.77	20.02	20.44	25.31746	24.56746	24.98746
20	16QAM	1	49	20.35	20.40	20.36	24.89746	24.94746	24.90746
20	16QAM	1	99	20.01	20.59	20.36	24.55746	25.13746	24.90746

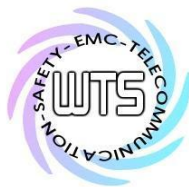

# Worldwide Testing Services(Taiwan) Co., Ltd.

Registration number: W6M22410-23833-C-247

FCC ID: GX9HYBLI

Band 40

BW(MHz)	Modulation	RB Size	RB offset	POWER(dBm)	POWER(dBm)	POWER(dBm)	EIRP	EIRP	EIRP
				Low Ch38675/2302.5MHz	Mid Ch39150/2350MHz	High Ch39625/2397.5MHz	Low Ch38675/2302.5MHz	Mid Ch39150/2350MHz	High Ch39625/2397.5MHz
5	QPSK	1	0	21.89	21.53	21.39	25.11756	24.75756	24.61756
5	QPSK	1	12	22.02	21.68	21.86	25.24756	24.90756	25.08756
5	QPSK	1	24	21.63	21.36	21.69	24.85756	24.58756	24.91756
5	QPSK	12	0	20.91	20.55	20.48	24.13756	23.77756	23.70756
5	QPSK	12	6	20.92	20.61	20.75	24.14756	23.83756	23.97756
5	QPSK	12	13	21.02	20.47	20.73	24.24756	23.69756	23.95756
5	QPSK	25	0	20.79	20.46	20.55	24.01756	23.68756	23.77756
5	16QAM	1	0	20.66	20.05	20.03	23.88756	23.27756	23.25756
5	16QAM	1	12	20.46	20.24	20.49	23.68756	23.46756	23.71756
5	16QAM	1	24	20.11	20.08	20.28	23.33756	23.30756	23.50756
BW(MHz)	Modulation	RB Size	RB offset	POWER(dBm)	POWER(dBm)	POWER(dBm)	EIRP	EIRP	EIRP
				Low Ch38700/2305MHz	Mid Ch39150/2350MHz	High Ch39600/2395MHz	Low Ch38700/2305MHz	Mid Ch39150/2350MHz	High Ch39600/2395MHz
10	QPSK	1	0	21.92	21.47	21.58	25.14756	24.69756	24.80756
10	QPSK	1	24	21.80	21.41	21.59	25.02756	24.63756	24.81756
10	QPSK	1	49	21.61	21.39	21.51	24.83756	24.61756	24.73756
10	QPSK	25	0	21.02	20.56	20.71	24.24756	23.78756	23.93756
10	QPSK	25	12	20.88	20.55	20.77	24.10756	23.77756	23.99756
10	QPSK	25	25	20.97	20.45	20.67	24.19756	23.67756	23.89756
10	QPSK	50	0	20.97	20.61	20.64	24.19756	23.83756	23.86756
10	16QAM	1	0	20.13	20.03	20.06	23.35756	23.25756	23.28756
10	16QAM	1	24	20.01	20.02	20.05	23.23756	23.24756	23.27756
10	16QAM	1	49	20.07	20.04	20.03	23.29756	23.26756	23.25756
BW(MHz)	Modulation	RB Size	RB offset	POWER(dBm)	POWER(dBm)	POWER(dBm)	EIRP	EIRP	EIRP
				Low Ch38725/2307.5MHz	Mid Ch39150/2350MHz	High Ch39575/2392.5MHz	Low Ch38725/2307.5MHz	Mid Ch39150/2350MHz	High Ch39575/2392.5MHz
15	QPSK	1	0	22.29	21.86	22.15	25.51756	25.08756	25.37756
15	QPSK	1	37	22.51	22.17	22.46	25.73756	25.39756	25.68756
15	QPSK	1	74	21.90	21.73	21.85	25.12756	24.95756	25.07756
15	QPSK	36	0	21.02	20.64	20.77	24.24756	23.86756	23.99756
15	QPSK	36	19	20.76	20.61	20.77	23.98756	23.83756	23.99756
15	QPSK	36	39	20.87	20.41	20.57	24.09756	23.63756	23.79756
15	QPSK	75	0	20.83	20.54	20.74	24.05756	23.76756	23.96756
15	16QAM	1	0	20.61	20.37	20.49	23.83756	23.59756	23.71756
15	16QAM	1	37	20.80	20.19	20.53	24.02756	23.41756	23.75756
15	16QAM	1	74	20.16	20.00	20.67	23.38756	23.22756	23.89756
BW(MHz)	Modulation	RB Size	RB offset	POWER(dBm)	POWER(dBm)	POWER(dBm)	EIRP	EIRP	EIRP
				Low Ch38750/2310MHz	Mid Ch39150/2350MHz	High Ch39550/2390MHz	Low Ch38750/2310MHz	Mid Ch39150/2350MHz	High Ch39550/2390MHz
20	QPSK	1	0	21.93	21.72	21.62	25.15756	24.94756	24.84756
20	QPSK	1	49	22.10	21.78	21.93	25.32756	25.00756	25.15756
20	QPSK	1	99	21.57	21.31	21.41	24.79756	24.53756	24.63756
20	QPSK	50	0	20.92	20.76	20.85	24.14756	23.98756	24.07756
20	QPSK	50	25	20.92	20.61	20.66	24.14756	23.83756	23.88756
20	QPSK	50	50	20.82	20.41	20.71	24.04756	23.63756	23.93756
20	QPSK	100	0	20.83	20.52	20.74	24.05756	23.74756	23.96756
20	16QAM	1	0	20.57	20.33	20.35	23.79756	23.55756	23.57756
20	16QAM	1	49	20.68	20.30	20.33	23.90756	23.52756	23.55756
20	16QAM	1	99	20.31	20.02	20.31	23.53756	23.24756	23.53756

Note:

EIRP = Conducted power + antenna gain

ERP = EIRP -2.15

Registration number: W6M22410-23833-C-247

FCC ID: GX9HYBLI

## 4 Modulation Characteristics

### 4.1 Test procedure

- A curve or equivalent data showing the frequency response of the audio modulating circuit over a range of 100 to 5000 Hz shall be submitted.  
The audio signal generator is connected to the audio input of the EUT with its full rating. The modulation response is measured at certain modulation frequencies, related to 1000Hz reference signal. Tests are performed for positive and negative modulation.
- Equipment which employs modulation Limiting: A curve or family of curves showing the percentage of modulation versus the modulation input voltage shall be supplied. The audio signal generator is connected to the audio input of the EUT with its full rating. The modulation limiting is measured at certain modulation frequencies from 100Hz to 15kHz.

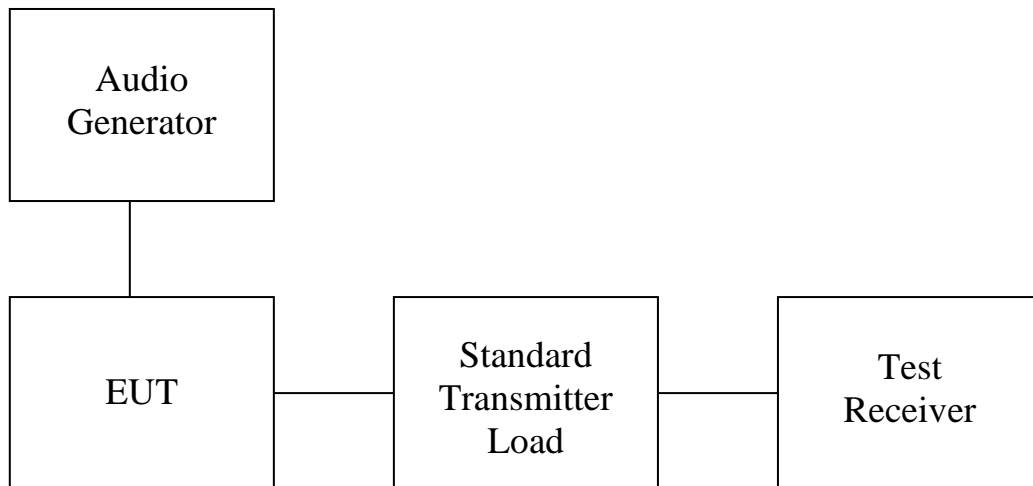

### 4.2 Test Results

For digital modulation employed, this test item is not applicable.



Registration number: W6M22410-23833-C-247

FCC ID: GX9HYBLI

## 5 Peak-to-Average Ratio

The peak-to-average power ratio (PAPR) of the transmitter output power must not exceed 13 dB. The PAPR measurements should be made using either an instrument with complementary cumulative distribution function (CCDF) capabilities to determine that PAPR will not exceed 13 dB for more than 0.1 percent of the time or other Commission approved procedure. The measurement must be performed using a signal corresponding to the highest PAPR expected during periods of continuous transmission.

### 5.1 Test procedure

1. The EUT main port was connected to the LTE emulator and spectrum analyzer via power divider
2. For Spectrum Analyzer setting :
3. Set the CCDF function in spectrum analyzer.
4. Set  $RBW \geq$  signal's occupied bandwidth.
5. Set the number of counts to a value that stabilizes the measured CCDF curve.
6. Set the measurement interval (sweep time) to 1ms.
7. The highest RF powers were measured and recorded the maximum PAPR level associated with a probability of 0.1%
8. Record the deviation as Peak to Average Ratio.

### 5.2 Test Set up

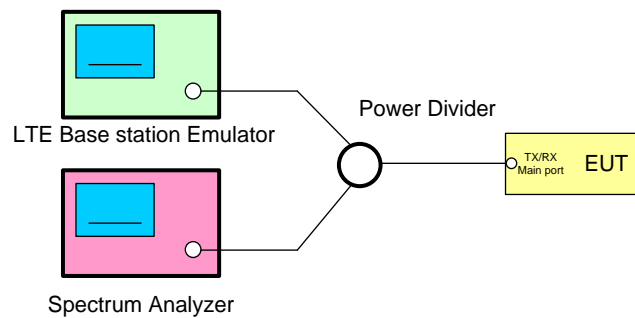





Registration number: W6M22410-23833-C-247

FCC ID: GX9HYBLI

**5.3 Test Results**

Test date: October 22, 2024

Temperature: 24.8 °C

Humidity: 55.3 %

Tester: Sora

Band 2  
20 MHz  
16QAM  
1RB

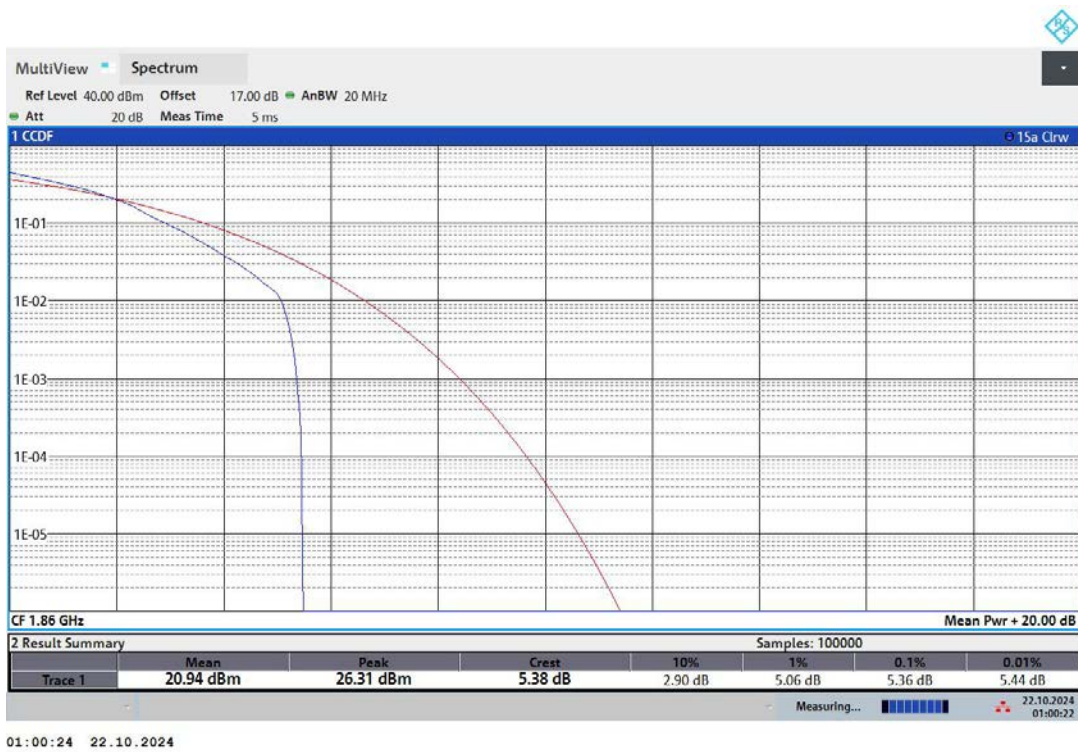

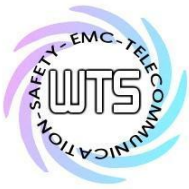

Registration number: W6M22410-23833-C-247  
 FCC ID: GX9HYBLI

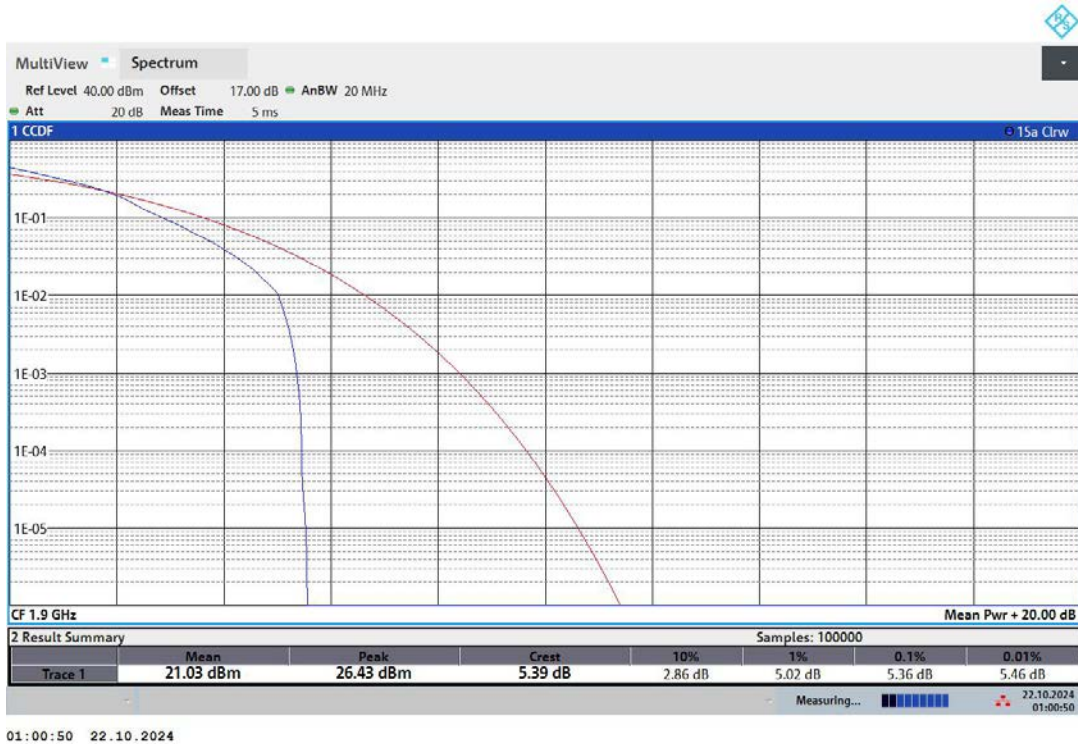
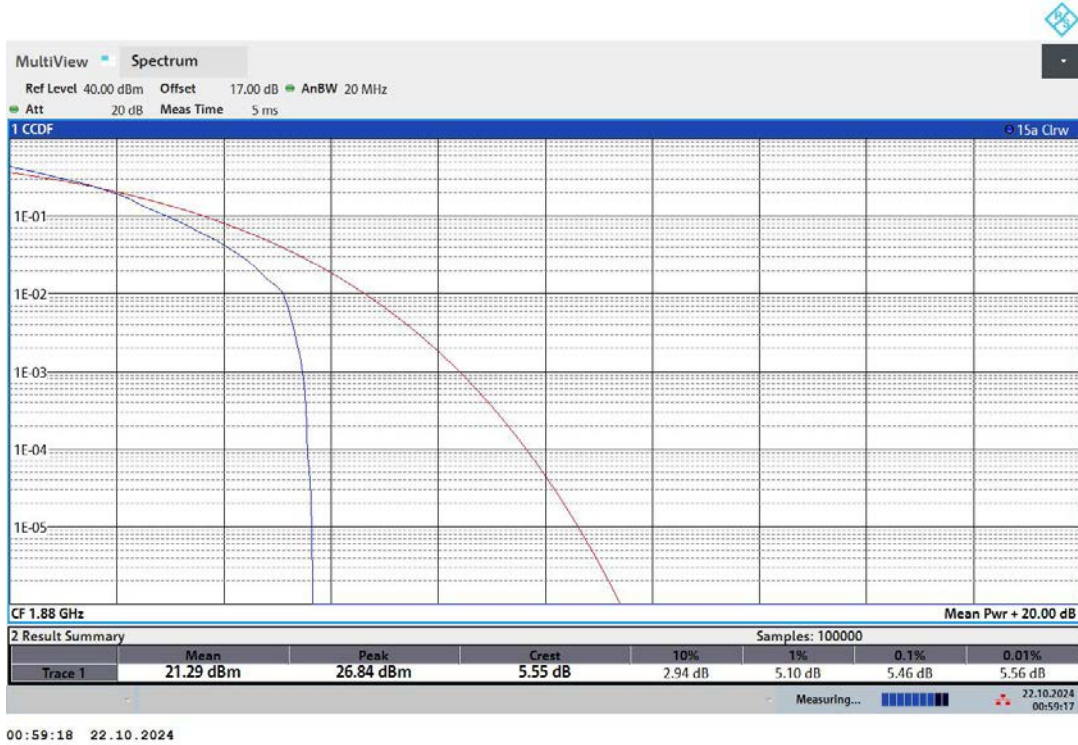



Registration number: W6M22410-23833-C-247

FCC ID: GX9HYBLI

Band 4

20 MHz

16QAM

1RB

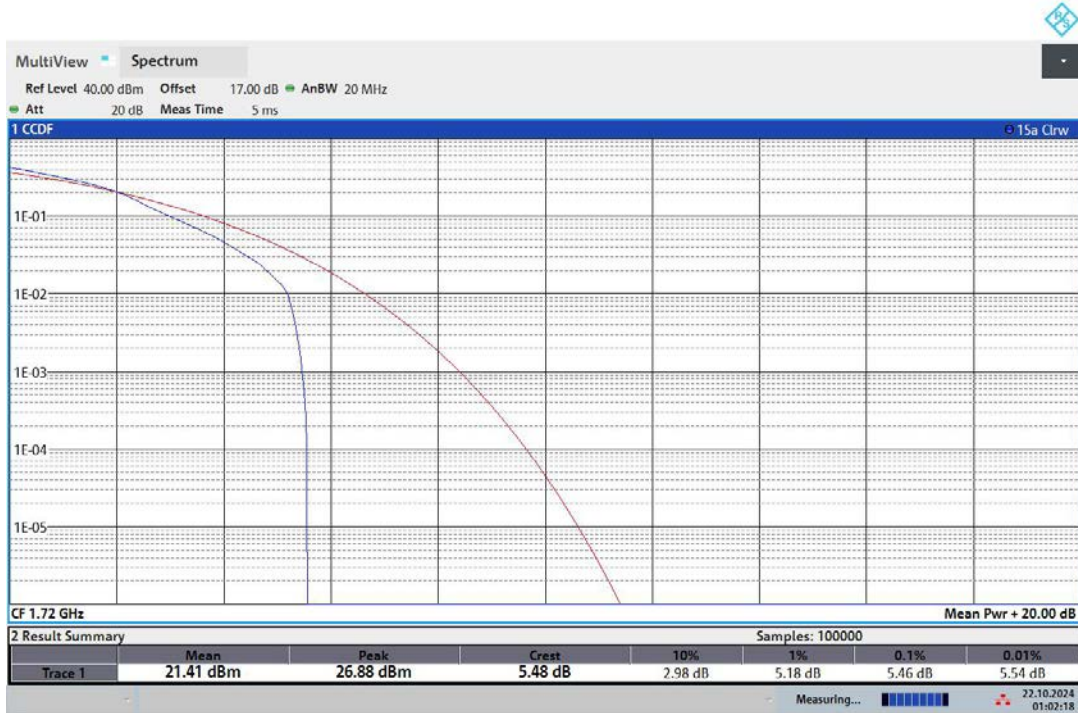

01:02:19 22.10.2024

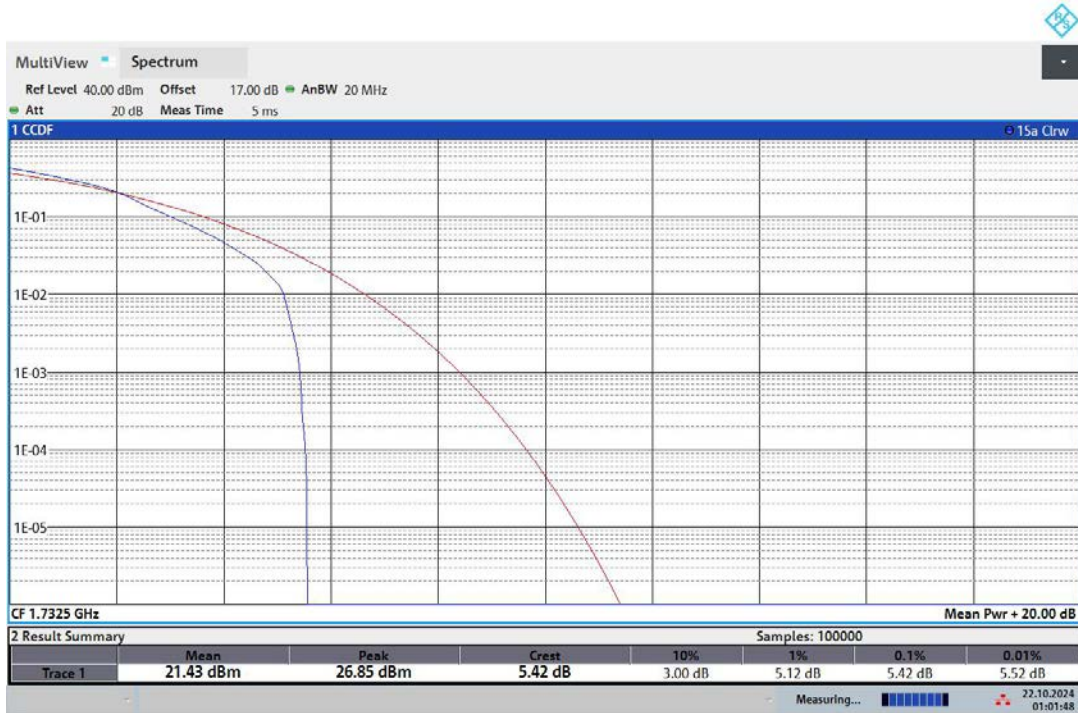

01:01:48 22.10.2024



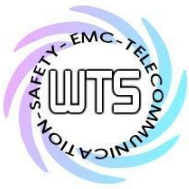

Registration number: W6M22410-23833-C-247  
 FCC ID: GX9HYBLI

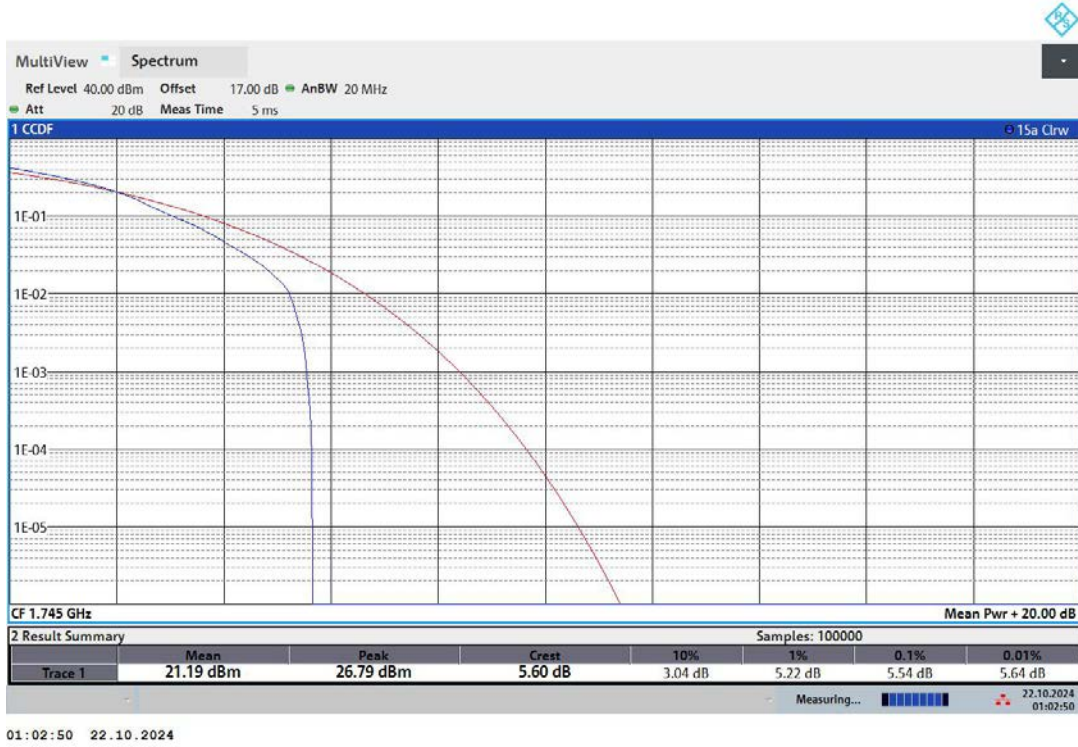

Band 5  
 10 MHz  
 16QAM  
 1RB

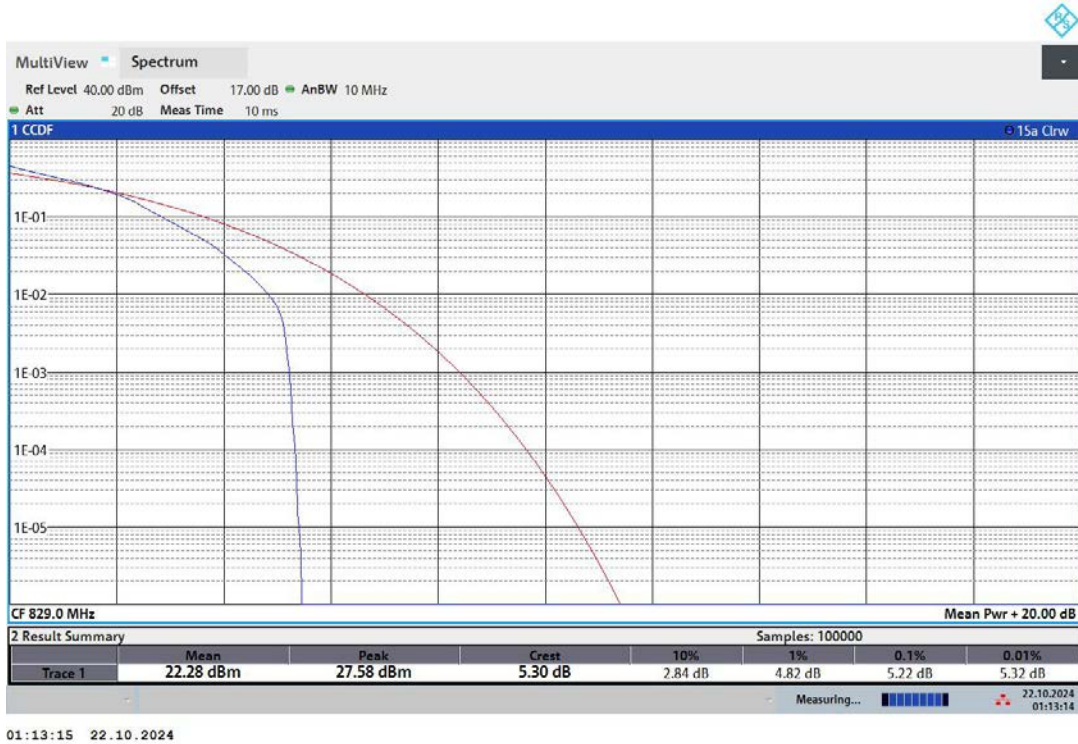

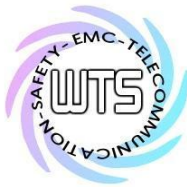

Registration number: W6M22410-23833-C-247  
 FCC ID: GX9HYBLI

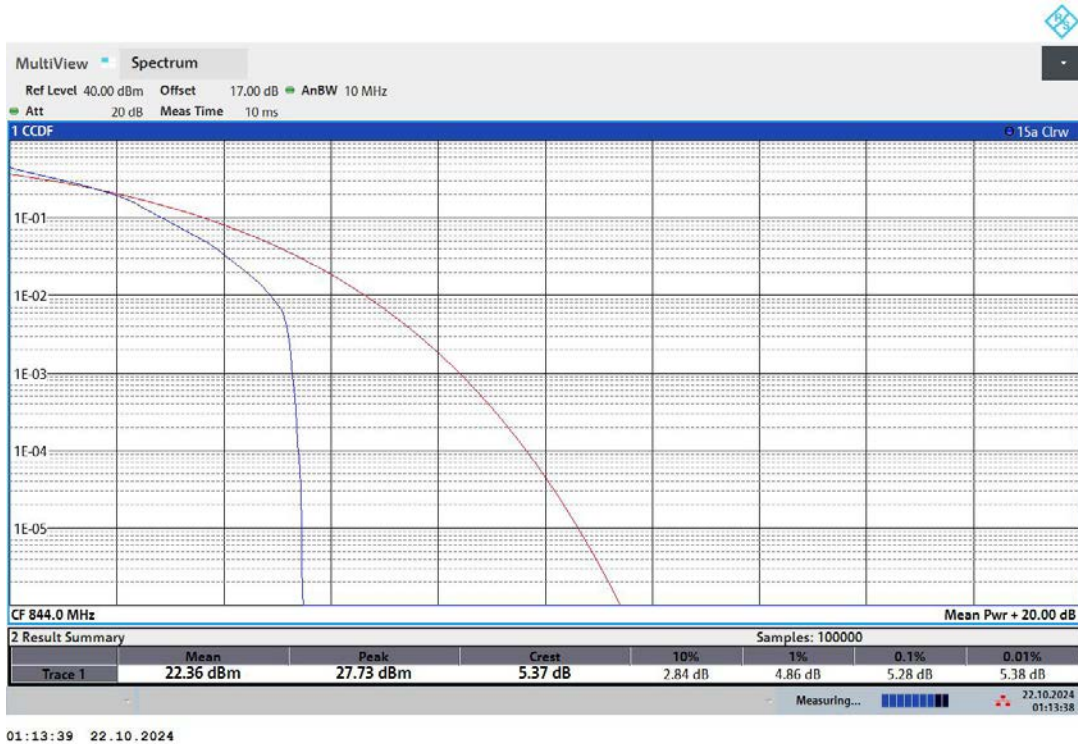





Registration number: W6M22410-23833-C-247

FCC ID: GX9HYBLI

Band 7

20 MHz

16QAM

1RB

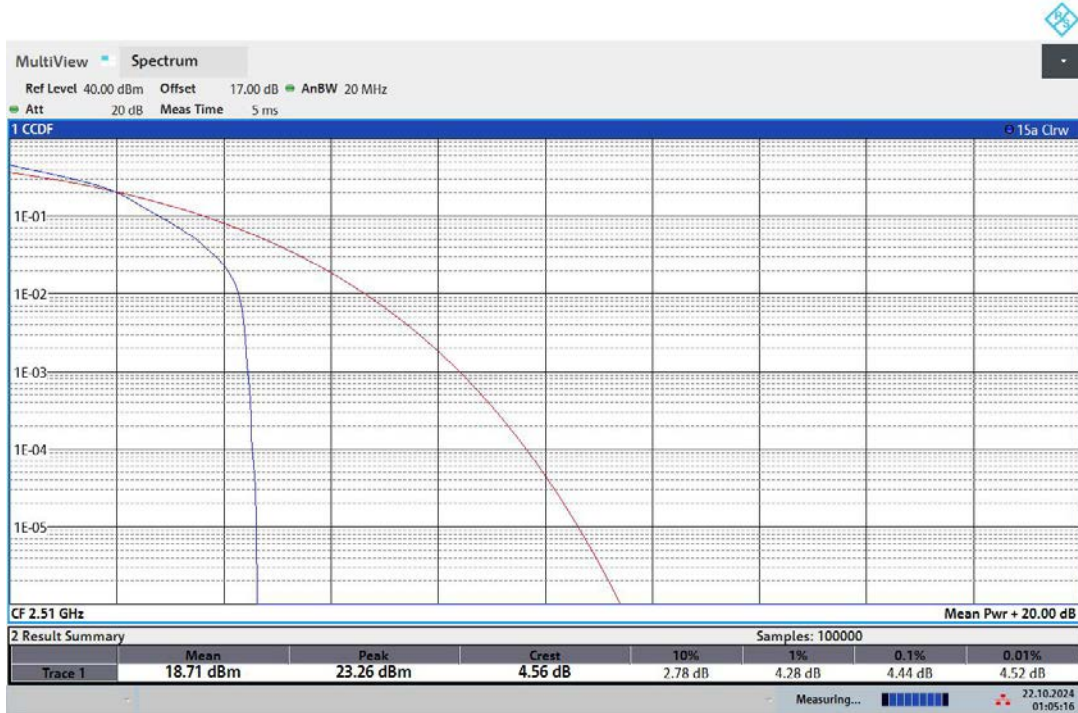

01:05:16 22.10.2024

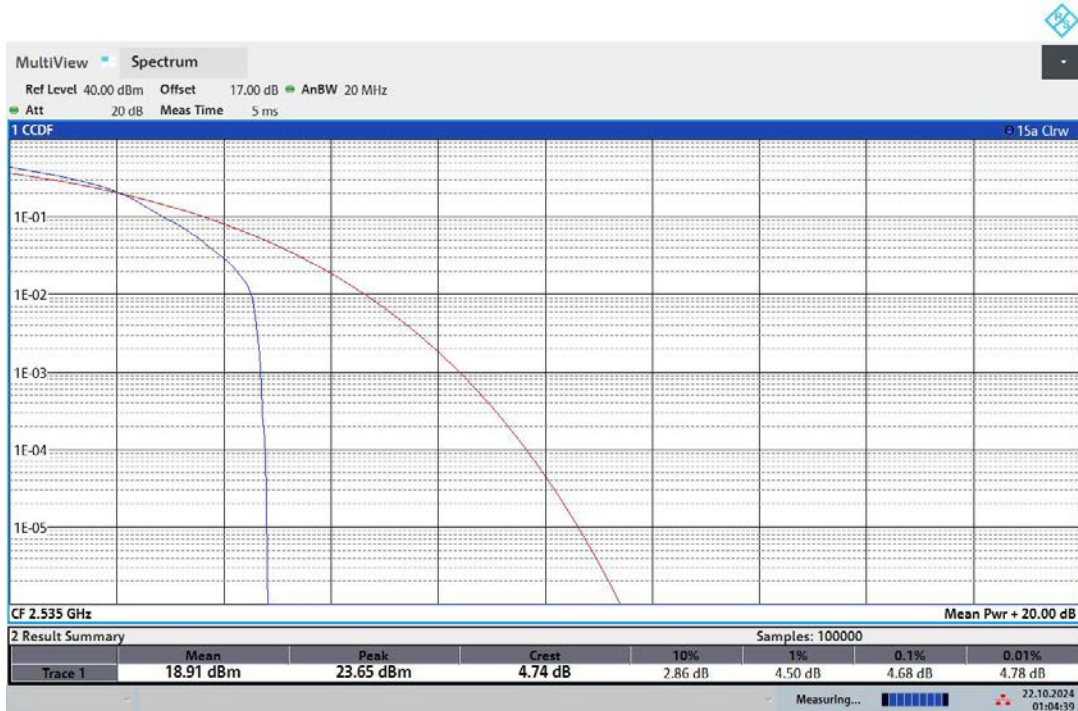

01:04:40 22.10.2024



Registration number: W6M22410-23833-C-247  
 FCC ID: GX9HYBLI



Band 40  
 20 MHz  
 16QAM  
 1RB

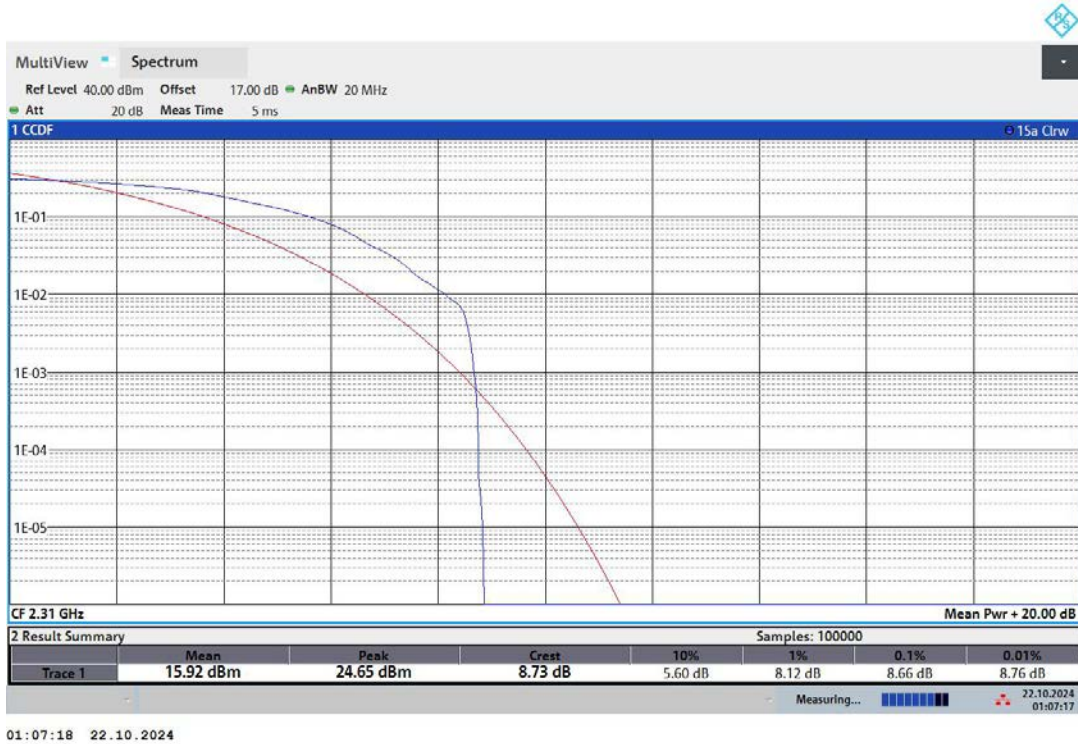





Registration number: W6M22410-23833-C-247  
 FCC ID: GX9HYBLI

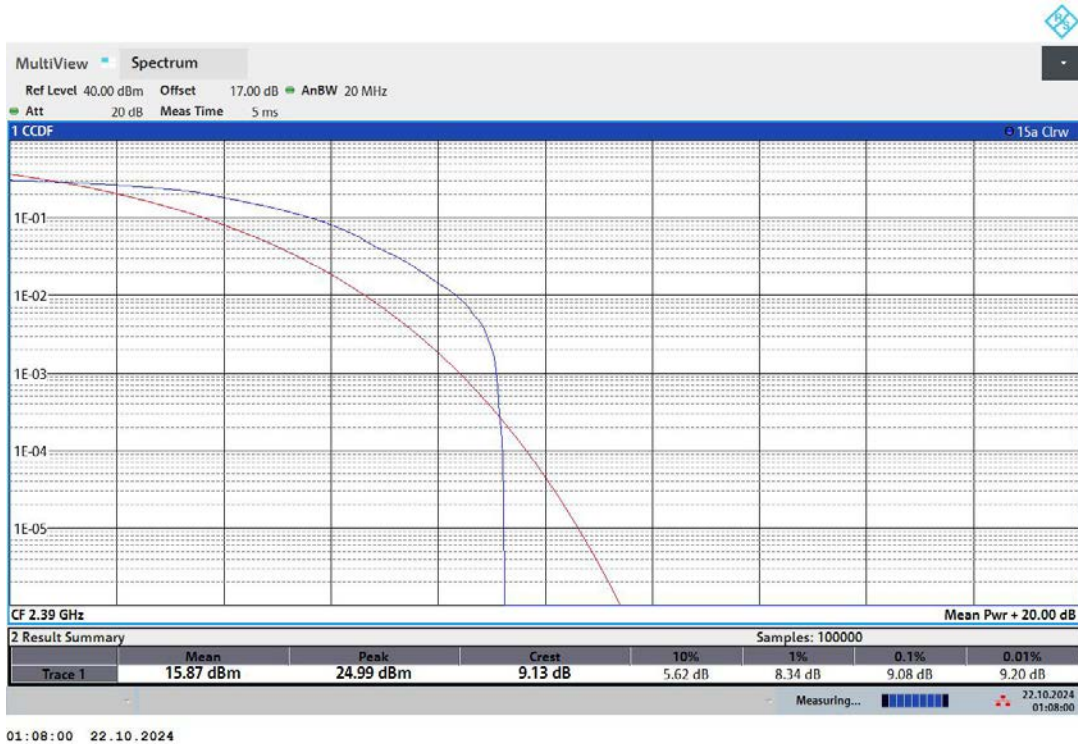

Limit according to FCC §24.232 and §27.50, The peak-to-average ratio(PAR) of the transmission may not exceed 13dB.



Registration number: W6M22410-23833-C-247

FCC ID: GX9HYBLI

**6 Occupied Bandwidth**

The occupied bandwidth (OBW) is the frequency bandwidth such that, below its lower and above its upper frequency limits, the mean powers radiated are each equal to a specified percentage 0.5% of the total mean transmitted power.

The 26 dB occupied bandwidth is the width of a frequency band such that, below its lower and above its upper frequency limits, the mean powers radiated are each equal 26 dB.

The 26 dB emission bandwidth is defined as the frequency range between two points, one above and one below the carrier frequency, at which the spectral density of the emission is attenuated 26 dB below the maximum in-band spectral density of the modulated signal. Spectral density (power per unit bandwidth) is to be measured with a detector of resolution bandwidth equal to approximately 1.0% of the emission bandwidth.

**6.1 Test procedure**

The RF output of the transceiver was connected as the following figure.

Occupied Bandwidth was measured with a occupied bandwidth function of the analyzer at 99% power was occupied. Then set the spectrum analyzer to cover the upper and lower band edges to measure emission mask.

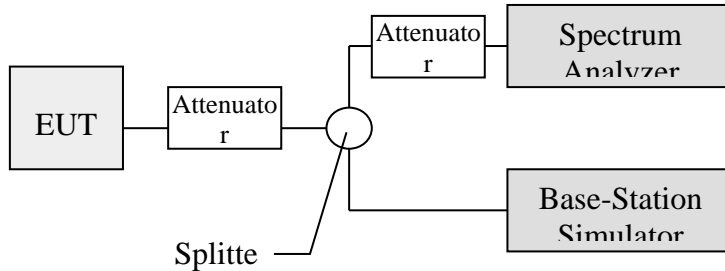



Registration number: W6M22410-23833-C-247

FCC ID: GX9HYBLI

## 6.2 Test Results

Test date: October 21, 2024

Temperature: 24.5 °C

Humidity: 58.7 %

Tester: Sora

Band 2

1.4 MHz

QPSK

FRB

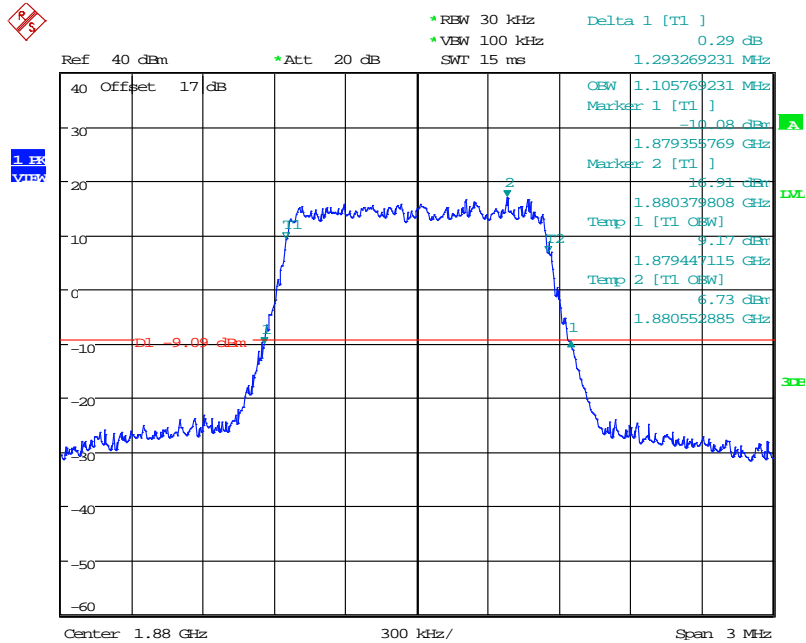

Date: 21.OCT.2024 16:43:04



Registration number: W6M22410-23833-C-247  
 FCC ID: GX9HYBLI  
 16QAM  
 FRB

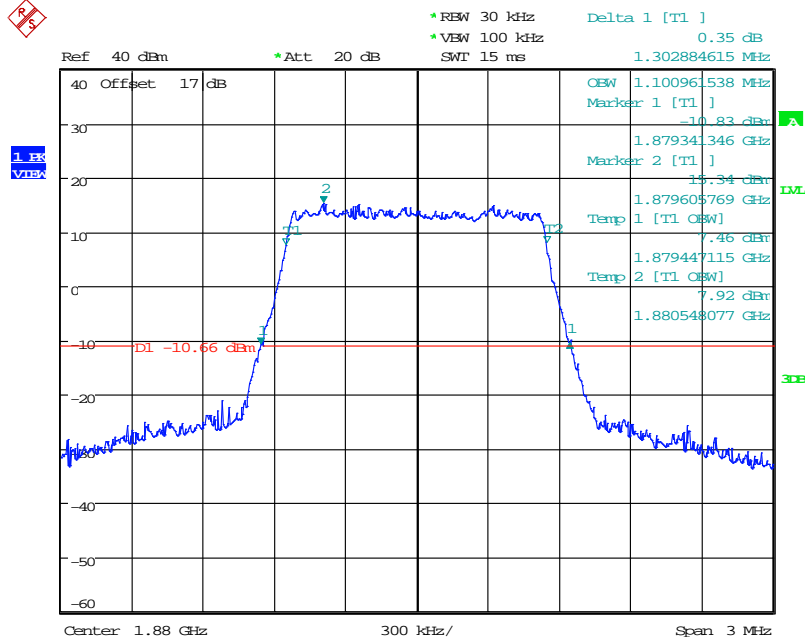

Date: 21.OCT.2024 16:43:51

3 MHz  
 QPSK  
 FRB

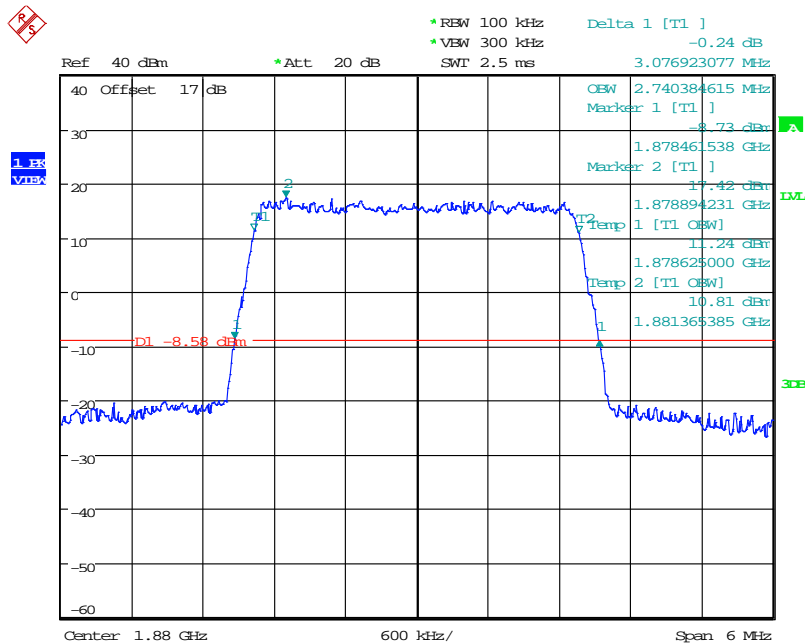

Date: 21.OCT.2024 16:56:20



Registration number: W6M22410-23833-C-247  
 FCC ID: GX9HYBLI  
 16QAM  
 12RB

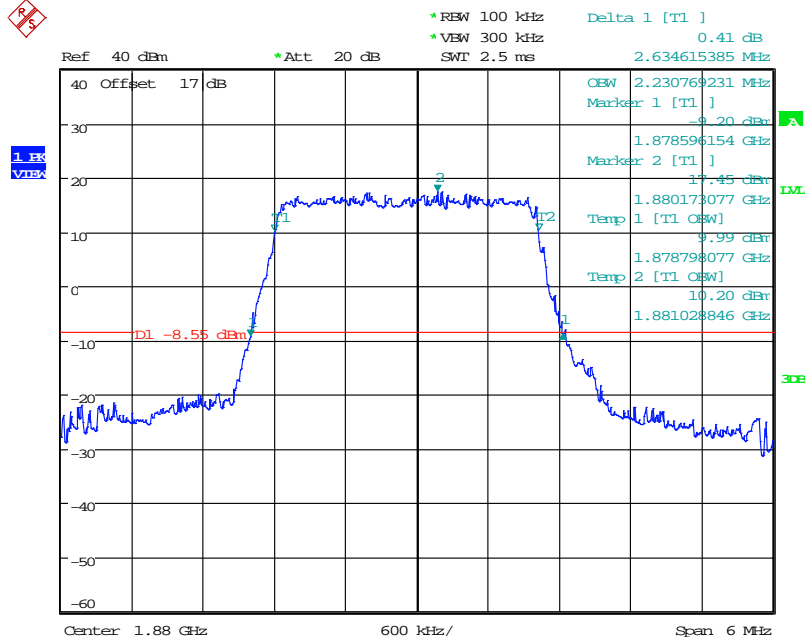

Date: 21.OCT.2024 16:58:54

5 MHz  
 QPSK  
 FRB

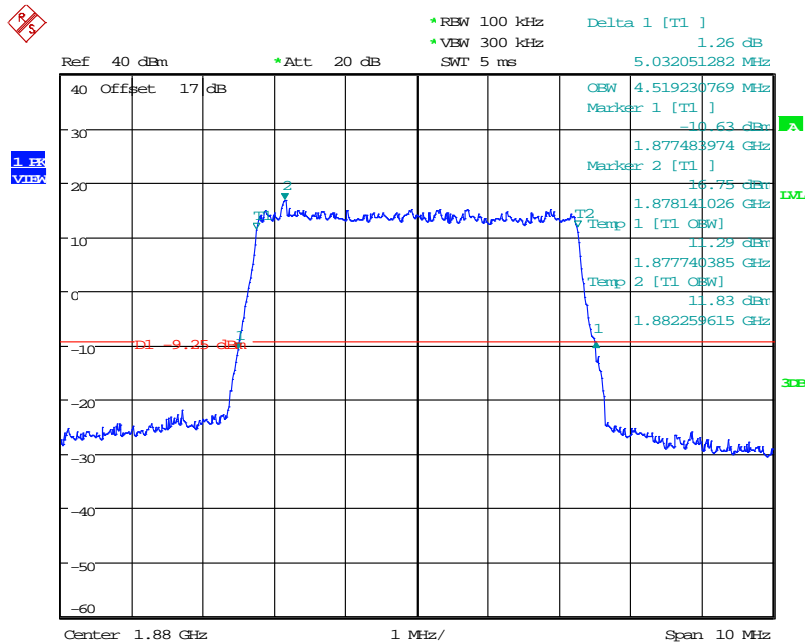

Date: 21.OCT.2024 17:15:39



Registration number: W6M22410-23833-C-247  
 FCC ID: GX9HYBLI  
 16QAM  
 12RB

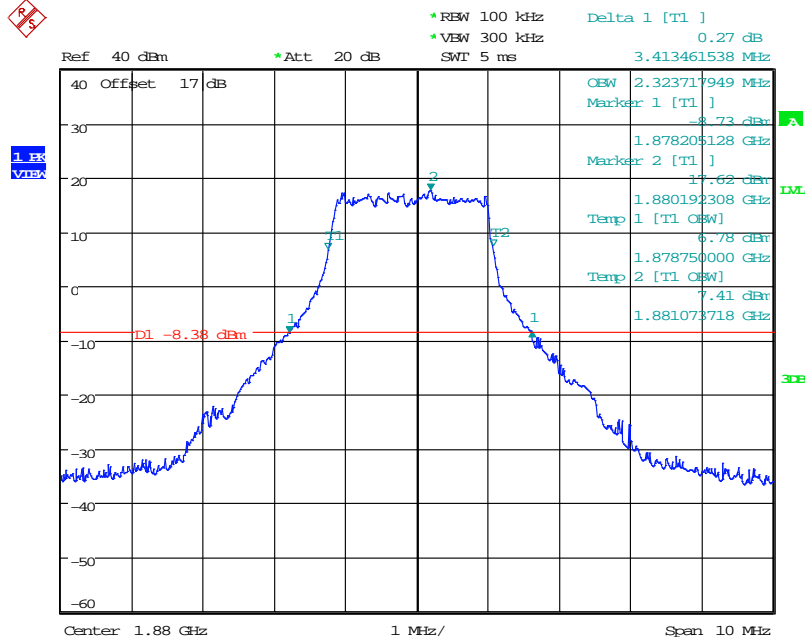

Date: 21.OCT.2024 17:14:21

10 MHz  
 QPSK  
 FRB

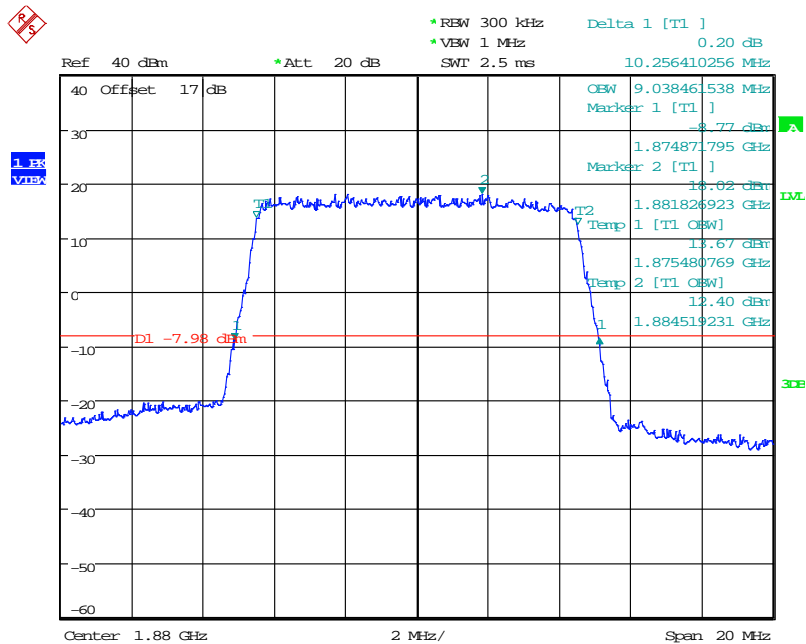

Date: 21.OCT.2024 17:51:51



Registration number: W6M22410-23833-C-247  
 FCC ID: GX9HYBLI  
 16QAM  
 12RB

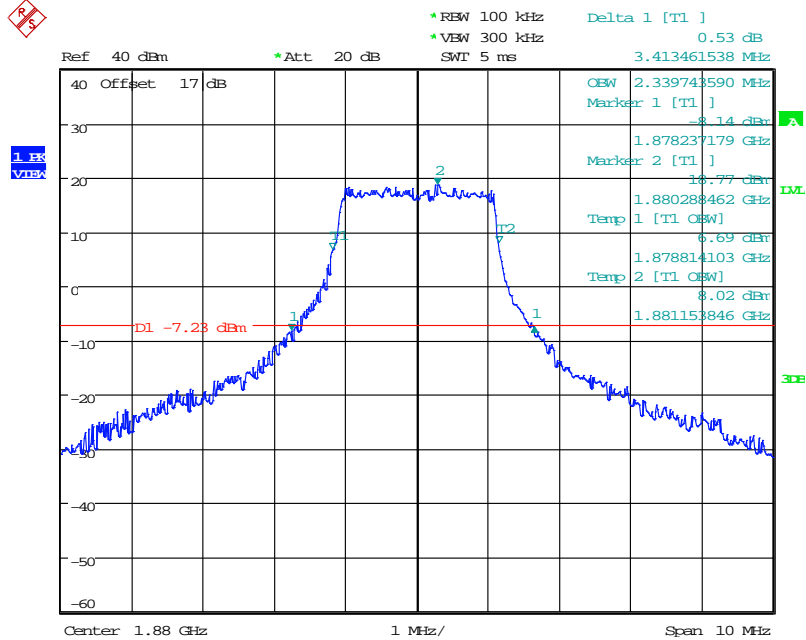

Date: 21.OCT.2024 17:39:35

15 MHz  
 QPSK  
 FRB

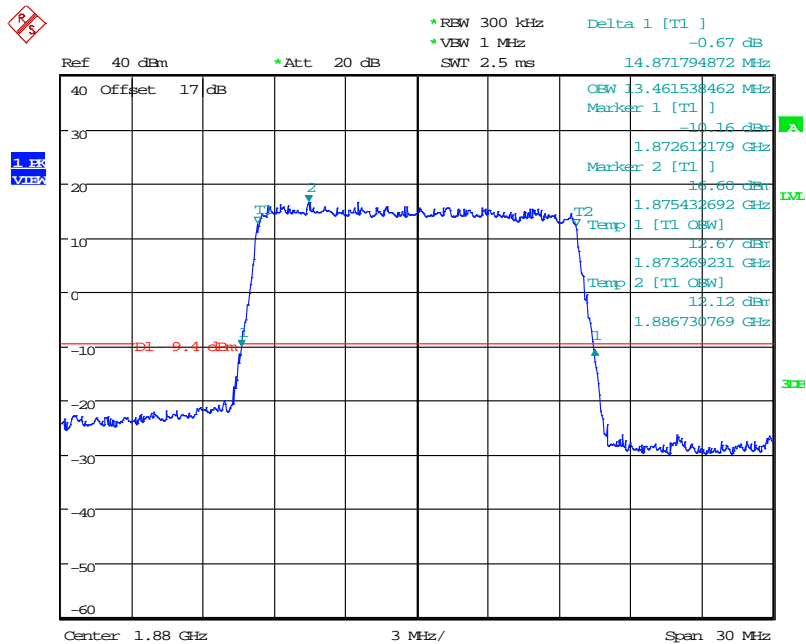

Date: 21.OCT.2024 17:53:02

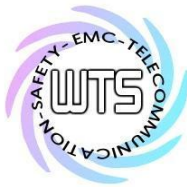

Registration number: W6M22410-23833-C-247  
 FCC ID: GX9HYBLI  
 16QAM  
 18RB

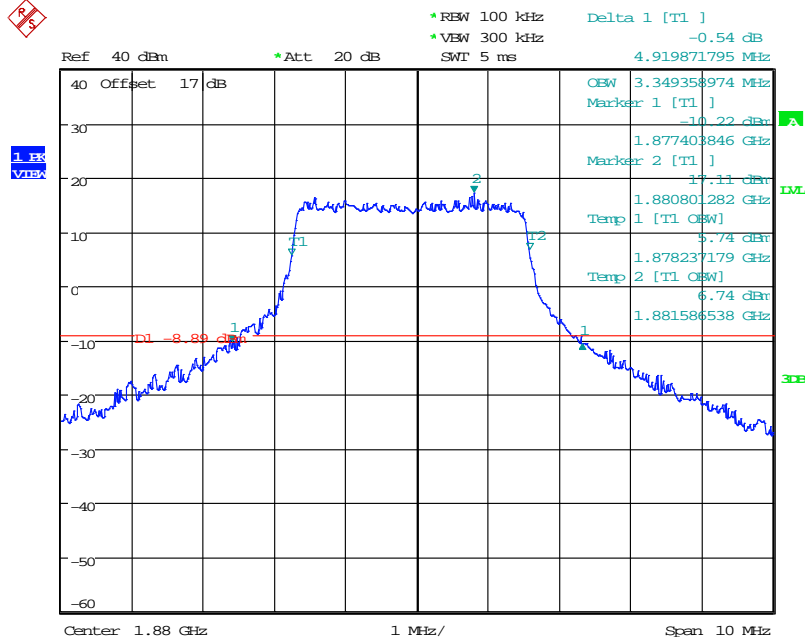

Date: 21.OCT.2024 18:11:30

20 MHz  
 QPSK  
 FRB

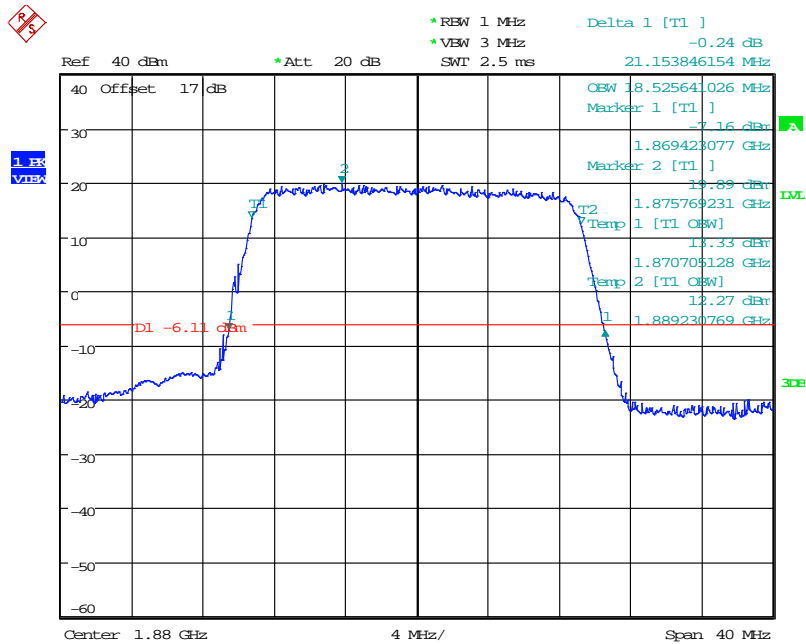

Date: 21.OCT.2024 18:26:58



Registration number: W6M22410-23833-C-247  
 FCC ID: GX9HYBLI  
 16QAM  
 18RB

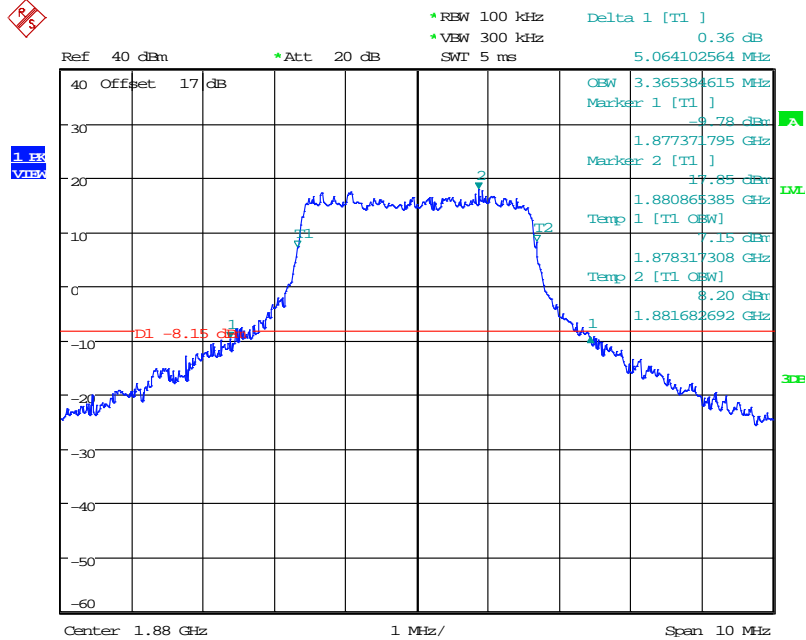

Date: 21.OCT.2024 18:12:55

Band 4  
 1.4 MHz  
 QPSK  
 FRB

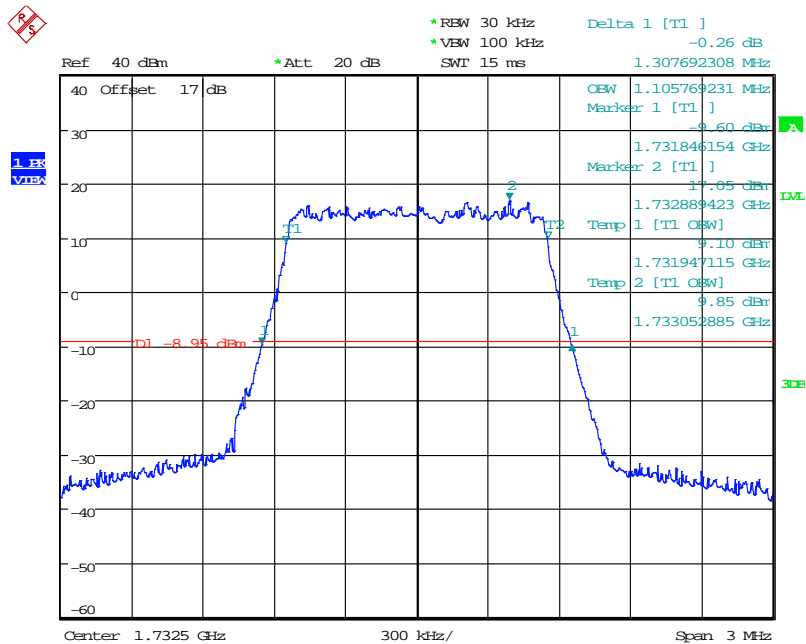

Date: 21.OCT.2024 16:46:30





Registration number: W6M22410-23833-C-247  
 FCC ID: GX9HYBLI  
 16QAM  
 FRB

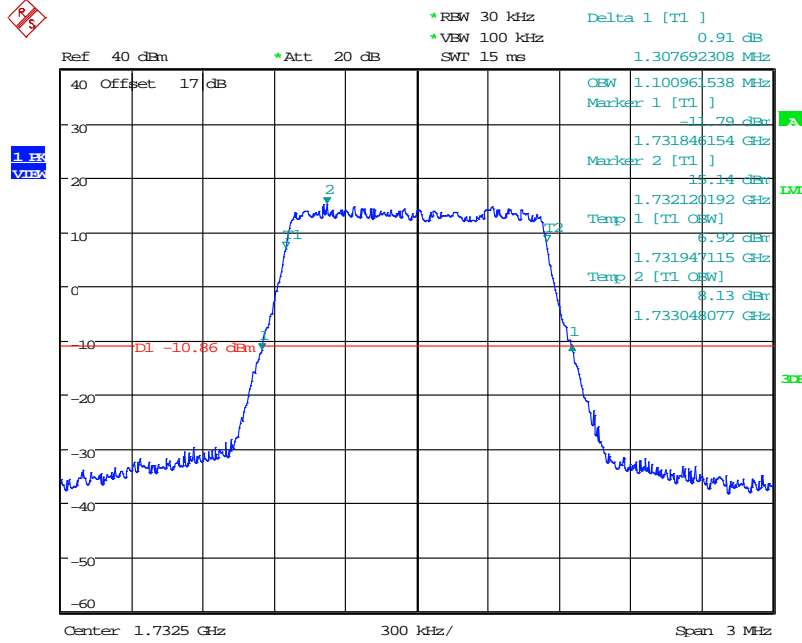

Date: 21.OCT.2024 16:44:43

3 MHz  
 QPSK  
 FRB

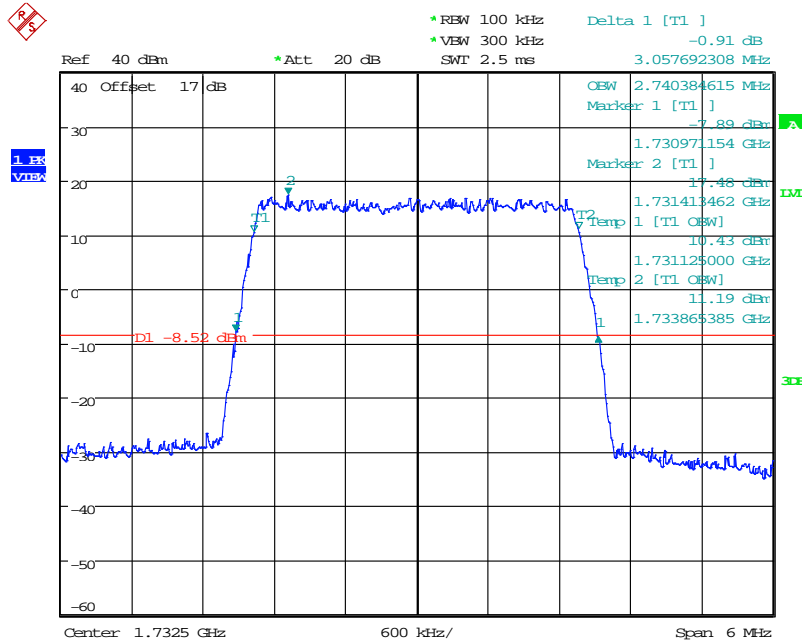

Date: 21.OCT.2024 16:55:16



Registration number: W6M22410-23833-C-247  
 FCC ID: GX9HYBLI  
 16QAM  
 12RB

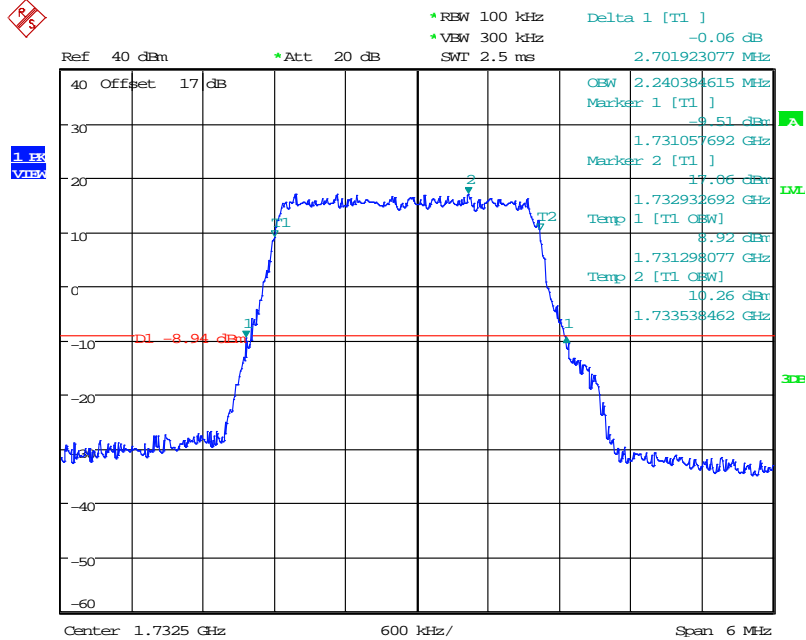

Date: 21.OCT.2024 16:54:22

5 MHz  
 QPSK  
 FRB

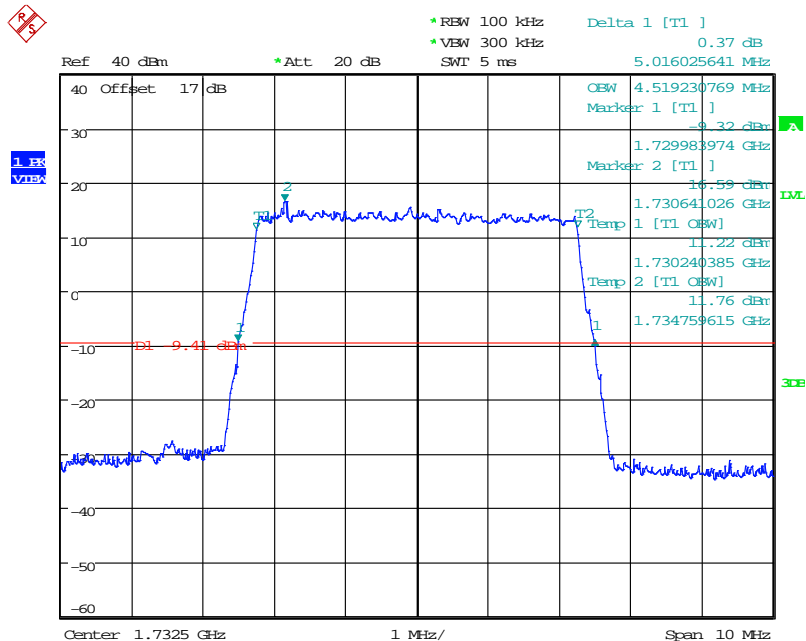

Date: 21.OCT.2024 17:16:49



Registration number: W6M22410-23833-C-247  
 FCC ID: GX9HYBLI  
 16QAM  
 12RB

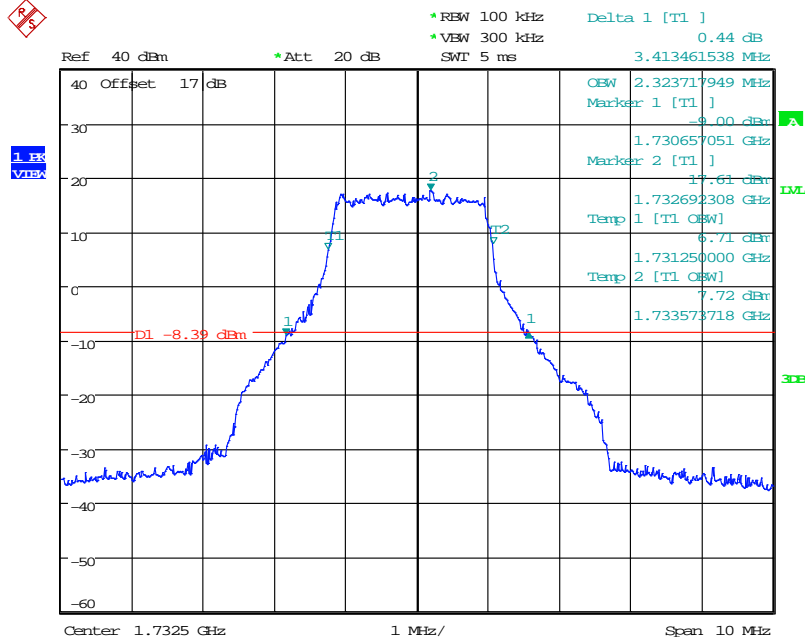

Date: 21.OCT.2024 17:13:10

10 MHz  
 QPSK  
 FRB

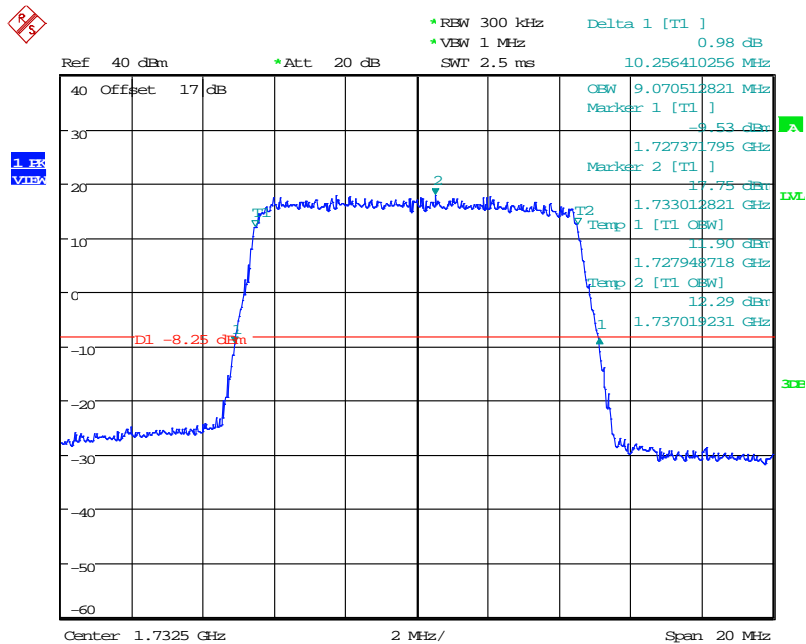

Date: 21.OCT.2024 17:50:52



Registration number: W6M22410-23833-C-247  
 FCC ID: GX9HYBLI  
 16QAM  
 12RB

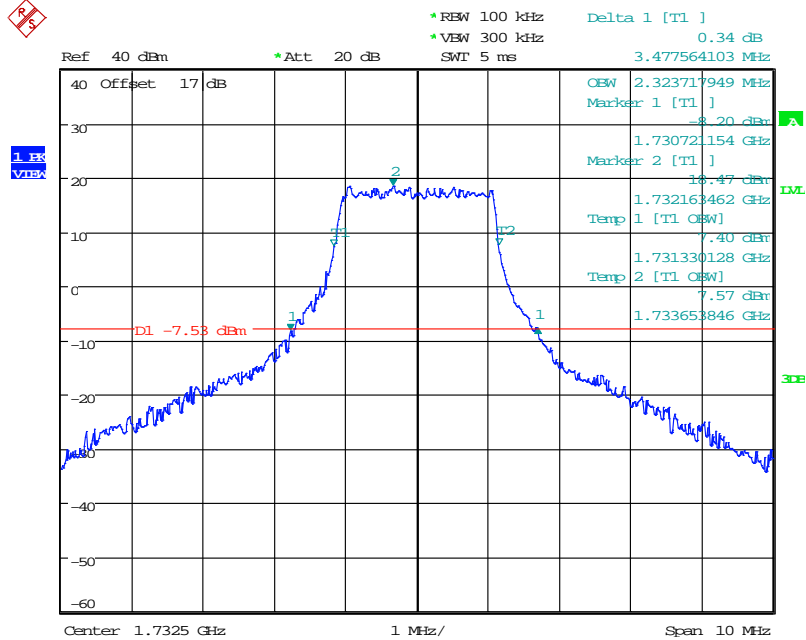

Date: 21.OCT.2024 17:40:40

15 MHz  
 QPSK  
 FRB

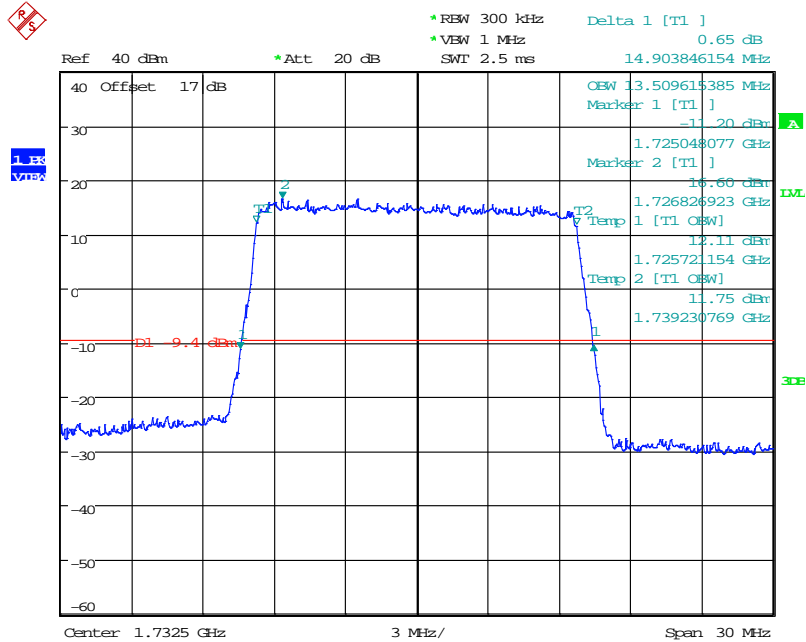

Date: 21.OCT.2024 17:54:09



Registration number: W6M22410-23833-C-247  
 FCC ID: GX9HYBLI  
 16QAM  
 18RB

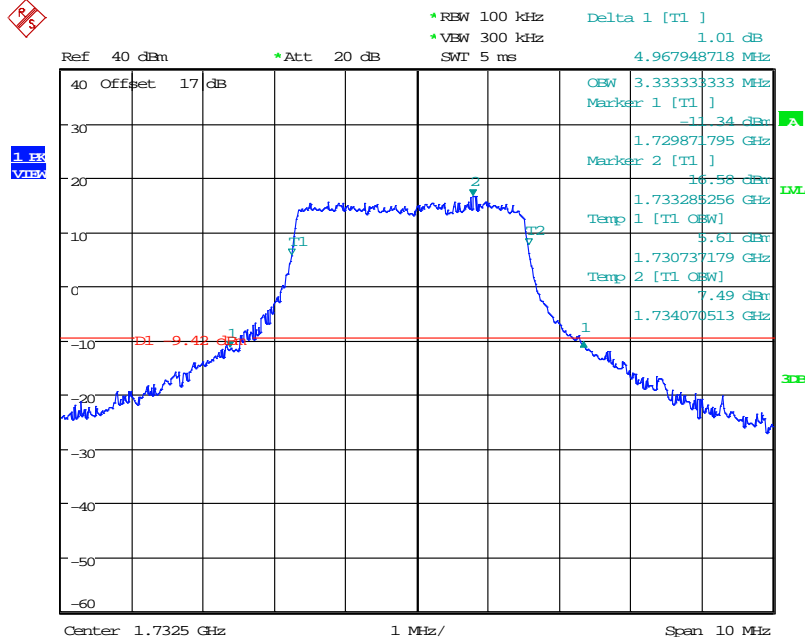

Date: 21.OCT.2024 18:10:31

20 MHz  
 QPSK  
 FRB

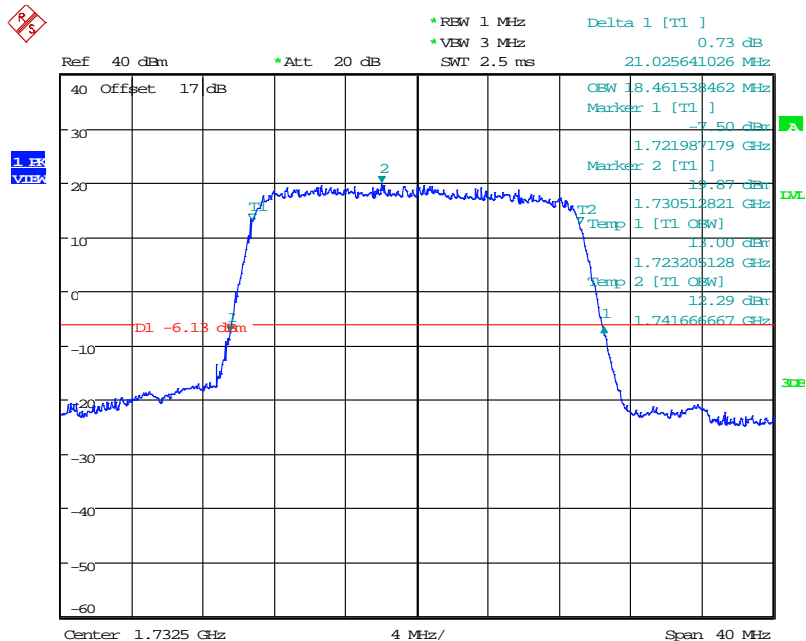

Date: 21.OCT.2024 18:26:11





Registration number: W6M22410-23833-C-247  
 FCC ID: GX9HYBLI  
 16QAM  
 18RB

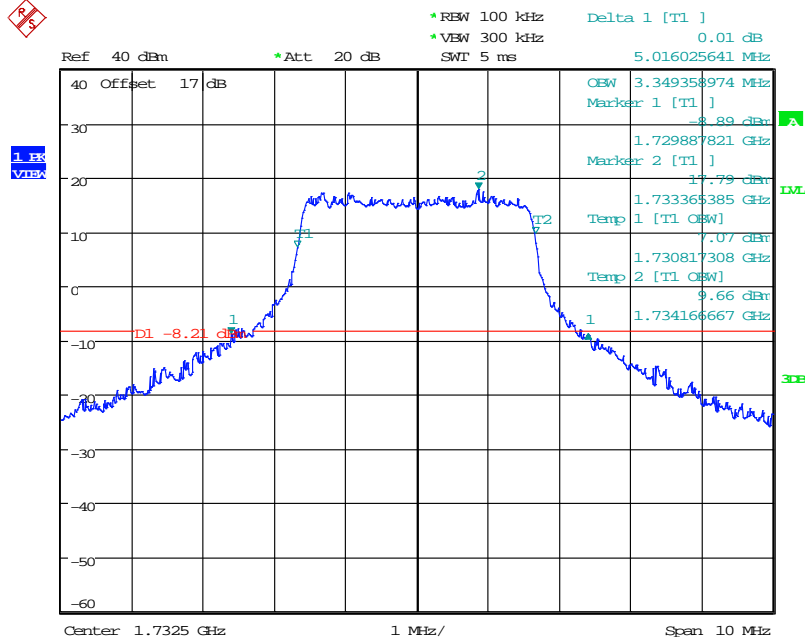

Date: 21.OCT.2024 18:14:02

Band 5  
 1.4 MHz  
 QPSK  
 FRB

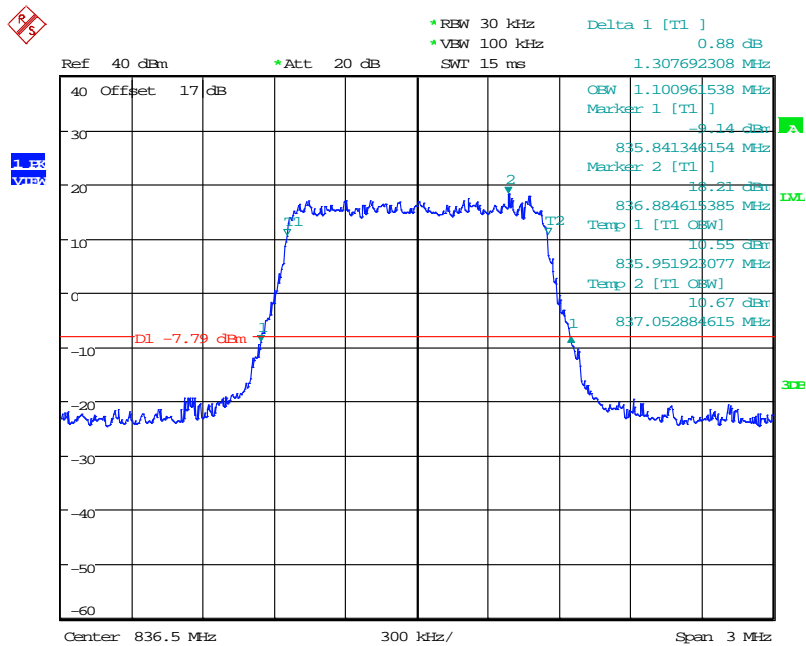

Date: 21.OCT.2024 16:47:26



Registration number: W6M22410-23833-C-247  
 FCC ID: GX9HYBLI  
 16QAM  
 FRB

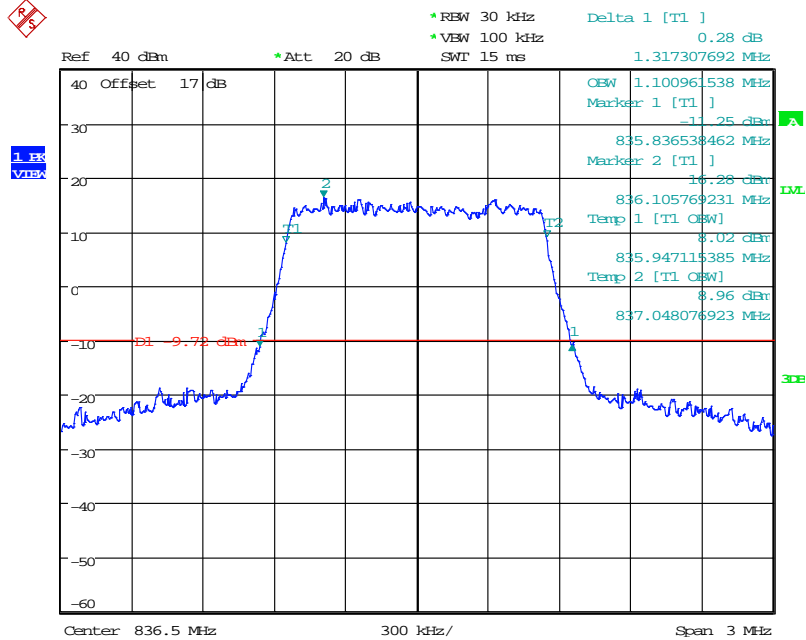

Date: 21.OCT.2024 16:48:21

3 MHz  
 QPSK  
 FRB

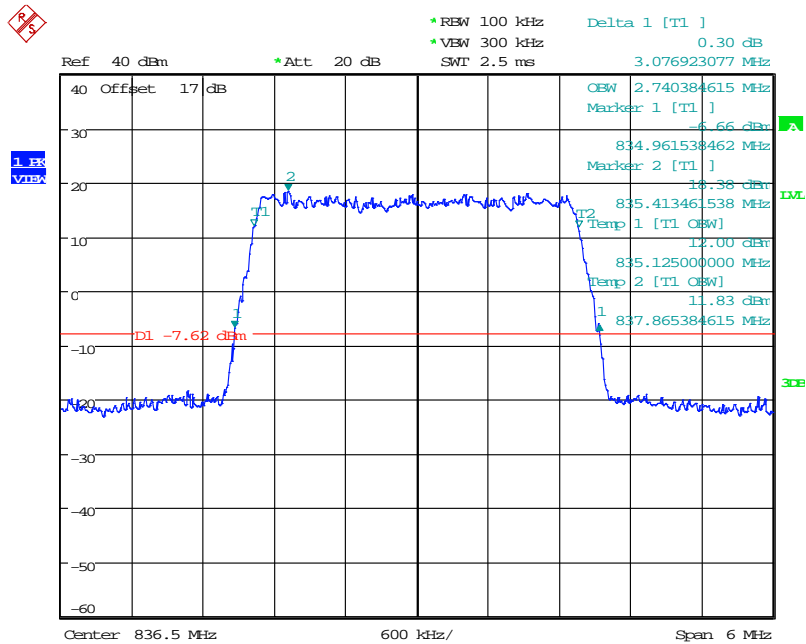

Date: 21.OCT.2024 16:51:13



Registration number: W6M22410-23833-C-247  
 FCC ID: GX9HYBLI  
 16QAM  
 12RB

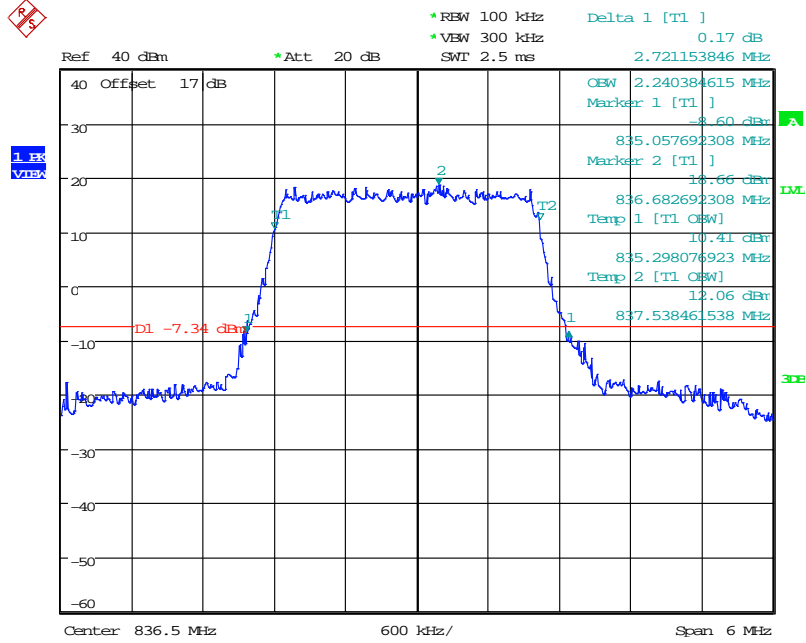

Date: 21.OCT.2024 16:52:53

5 MHz  
 QPSK  
 FRB

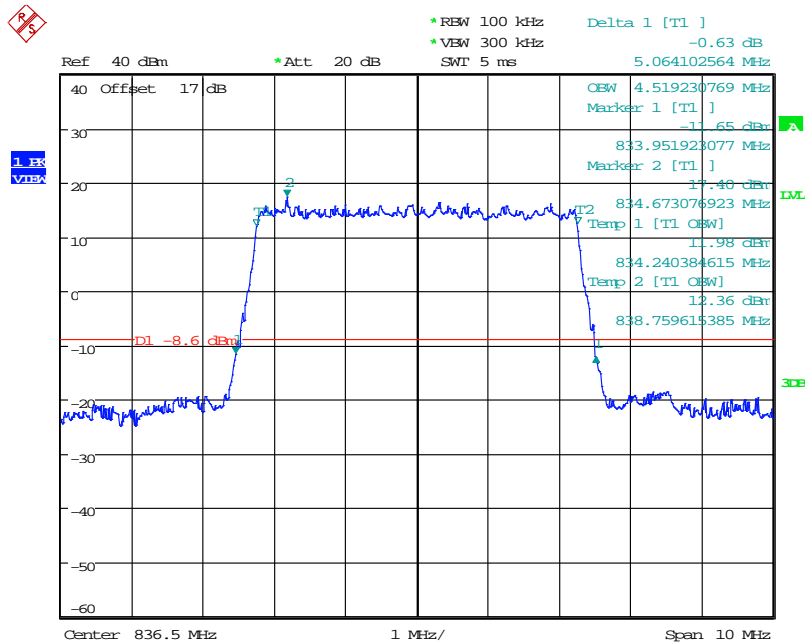

Date: 21.OCT.2024 17:18:10



Registration number: W6M22410-23833-C-247  
 FCC ID: GX9HYBLI  
 16QAM  
 12RB

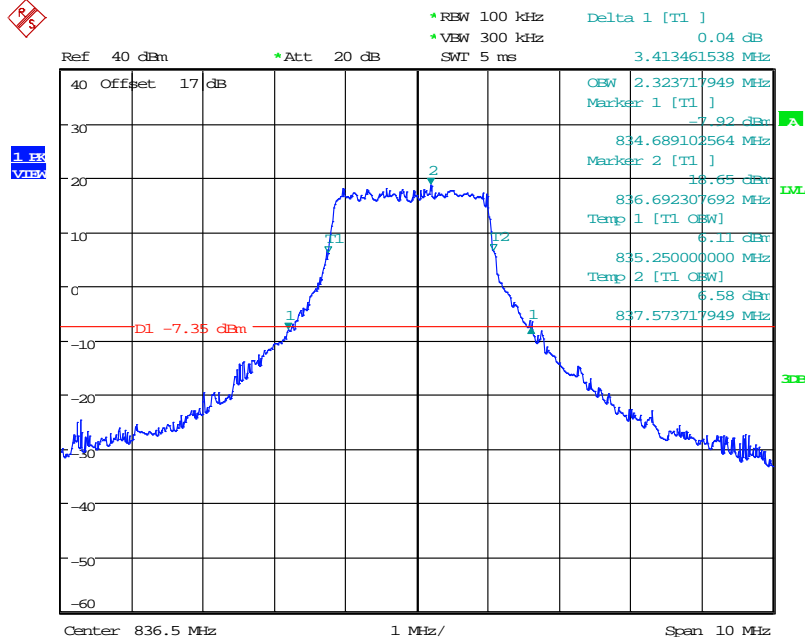

Date: 21.OCT.2024 17:12:01

10 MHz  
 QPSK  
 FRB

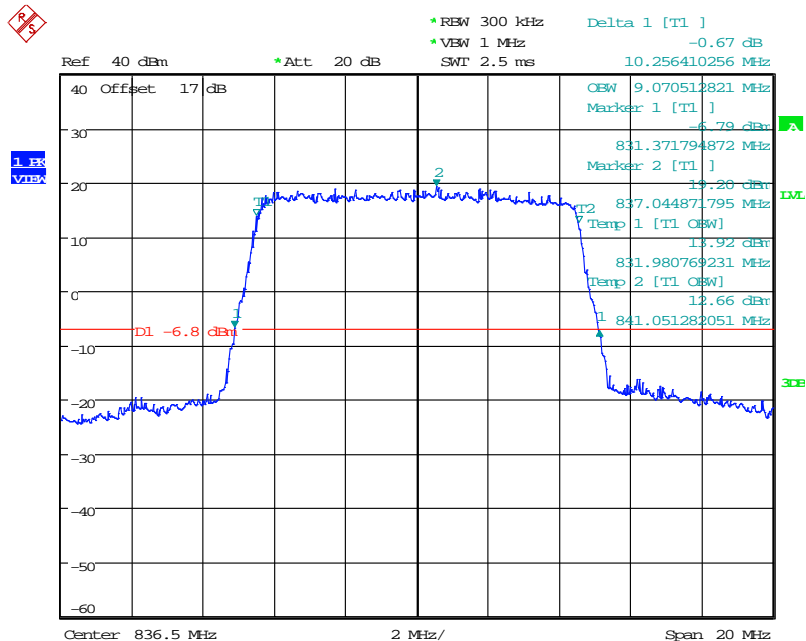

Date: 21.OCT.2024 17:49:58



Registration number: W6M22410-23833-C-247  
 FCC ID: GX9HYBLI  
 16QAM  
 12RB

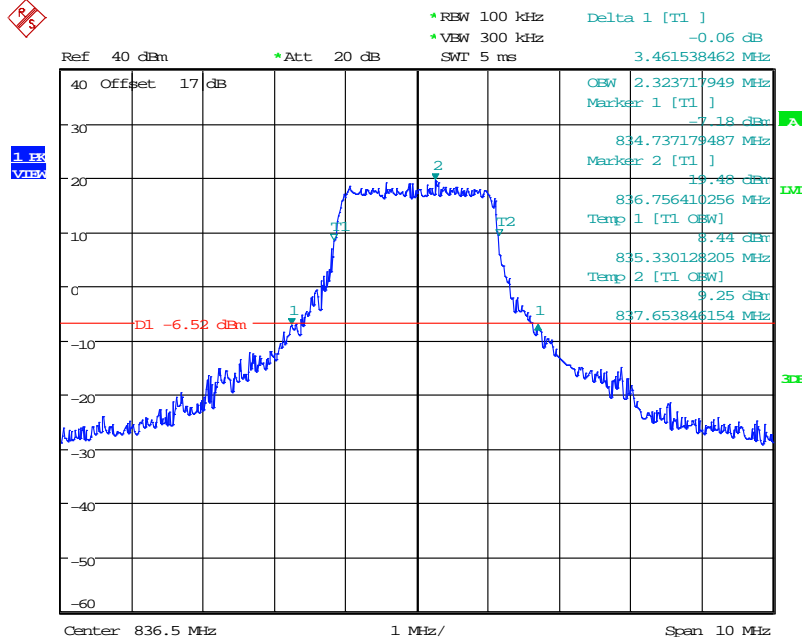

Date: 21.OCT.2024 17:41:50

Band 7  
 5 MHz  
 QPSK  
 FRB

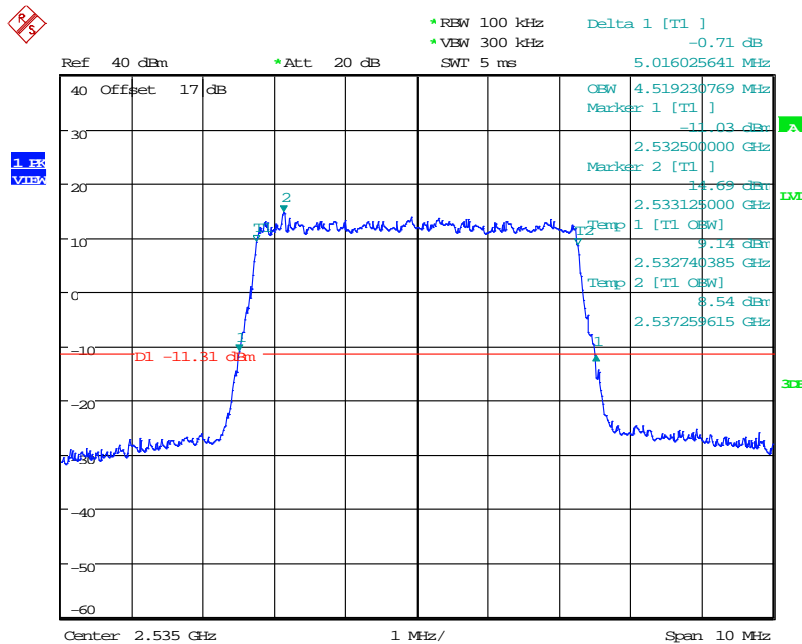

Date: 21.OCT.2024 17:19:44



Registration number: W6M22410-23833-C-247  
 FCC ID: GX9HYBLI  
 16QAM  
 12RB

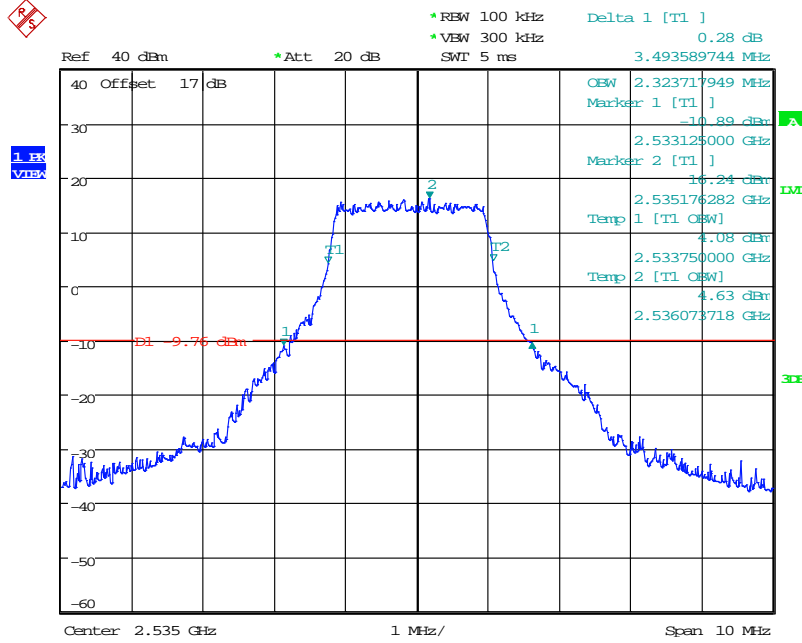

Date: 21.OCT.2024 17:10:28

10 MHz  
 QPSK  
 FRB

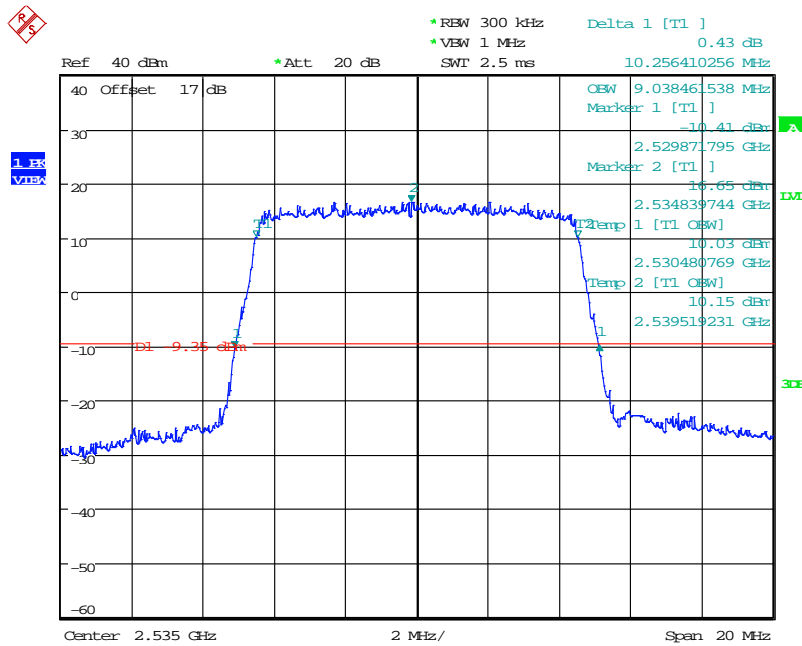

Date: 21.OCT.2024 17:47:56





Registration number: W6M22410-23833-C-247  
 FCC ID: GX9HYBLI  
 16QAM  
 12RB

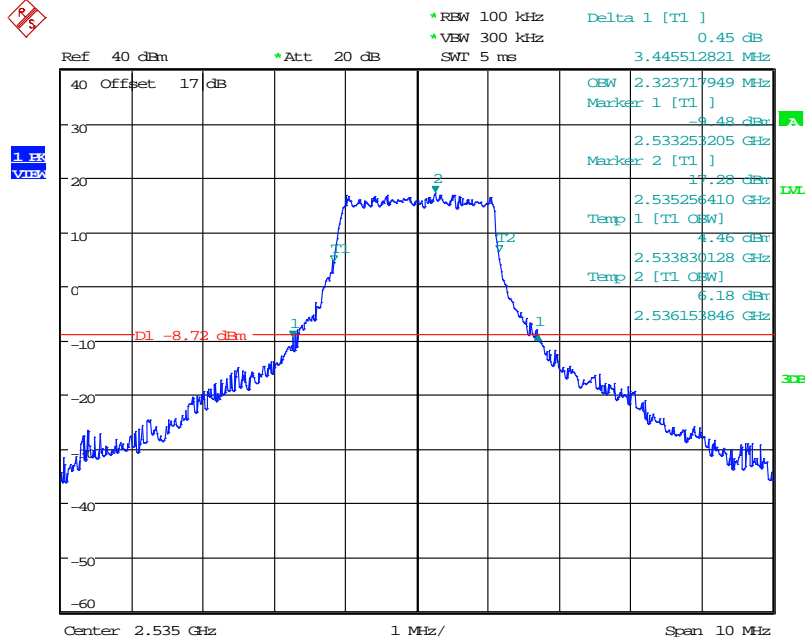

Date: 21.OCT.2024 17:36:01

15 MHz  
 QPSK  
 FRB

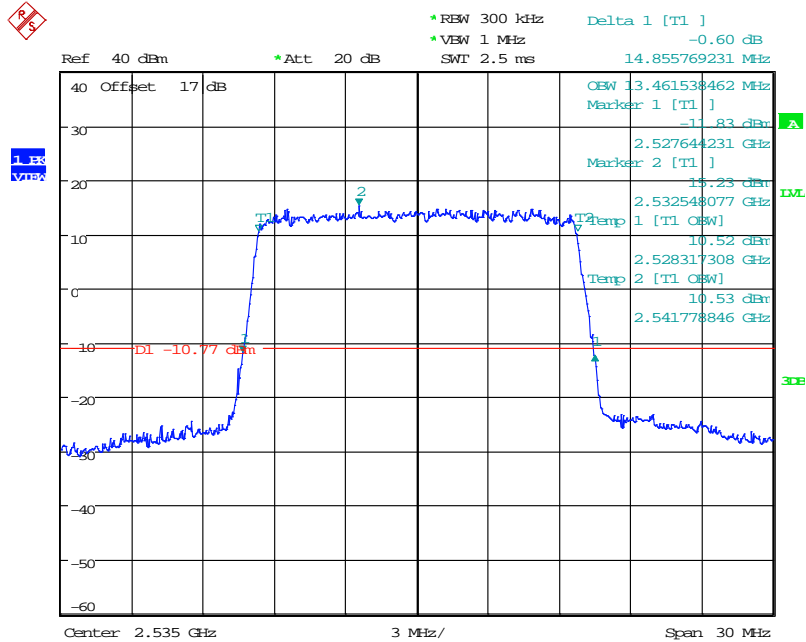

Date: 21.OCT.2024 18:02:16



Registration number: W6M22410-23833-C-247  
 FCC ID: GX9HYBLI  
 16QAM  
 18RB

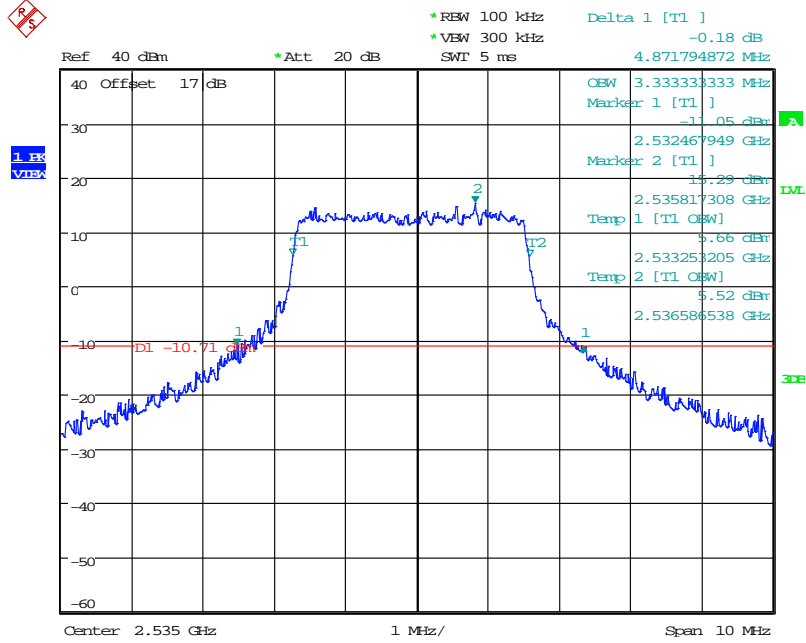

Date: 21.OCT.2024 18:08:02

20 MHz  
 QPSK  
 FRB

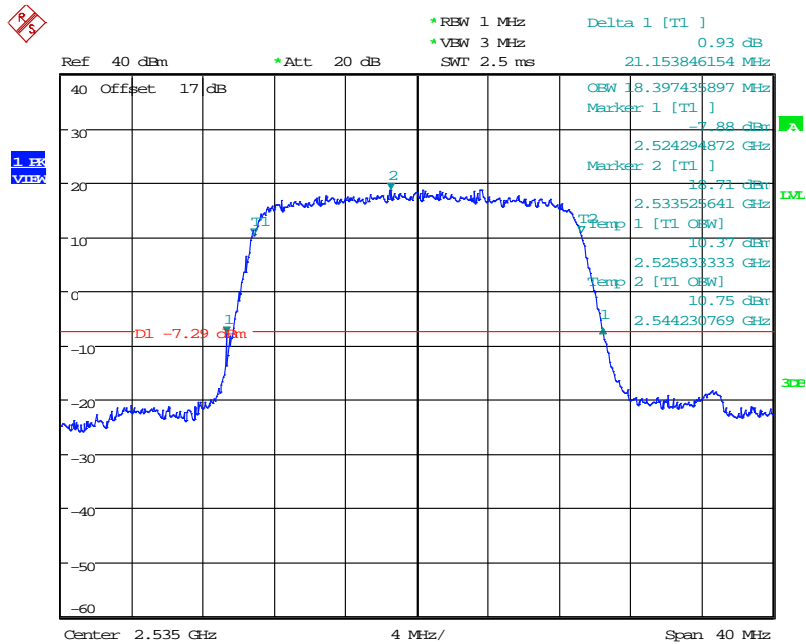

Date: 21.OCT.2024 18:24:19



Registration number: W6M22410-23833-C-247  
 FCC ID: GX9HYBLI  
 16QAM  
 18RB

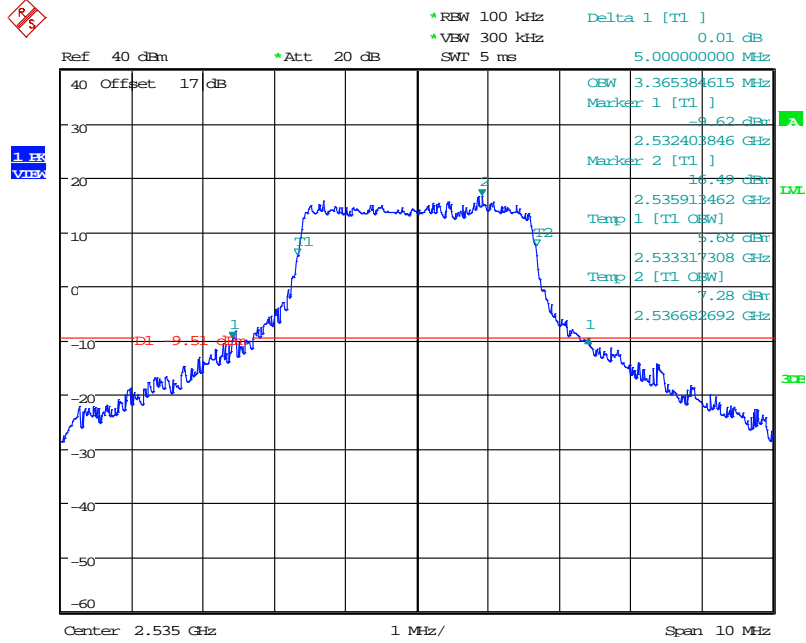

Date: 21.OCT.2024 18:17:06

Band 40  
 5 MHz  
 QPSK  
 FRB

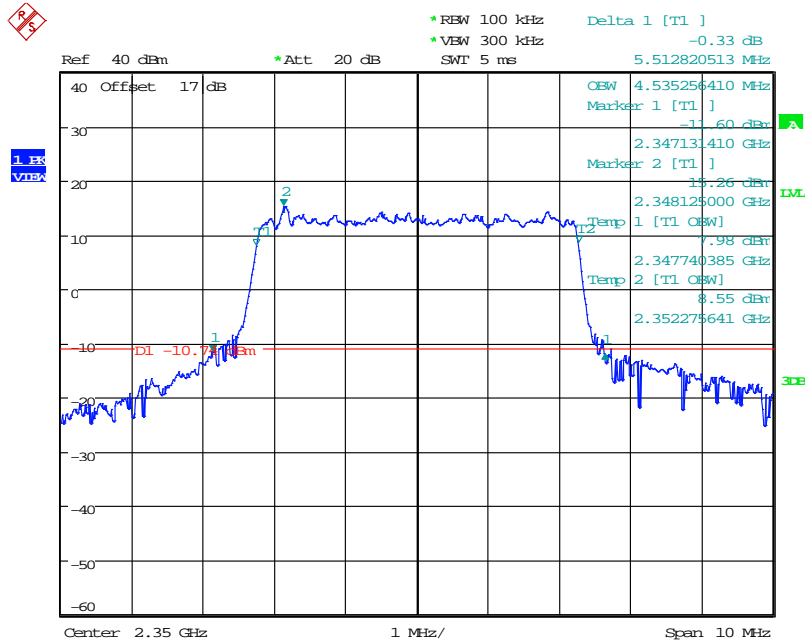

Date: 21.OCT.2024 17:21:54



Registration number: W6M22410-23833-C-247  
FCC ID: GX9HYBLI  
16QAM  
12RB

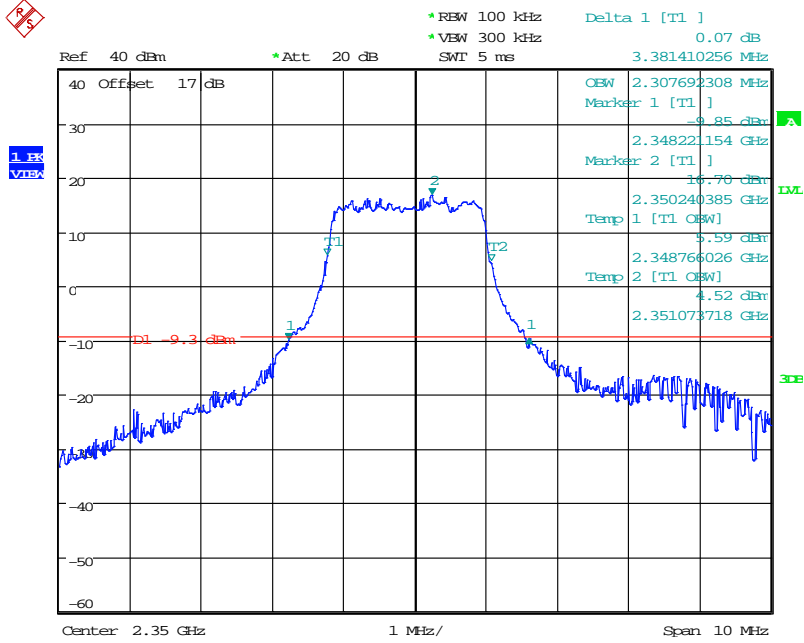

Date: 21.OCT.2024 17:08:45

10 MHz  
QPSK  
FRB

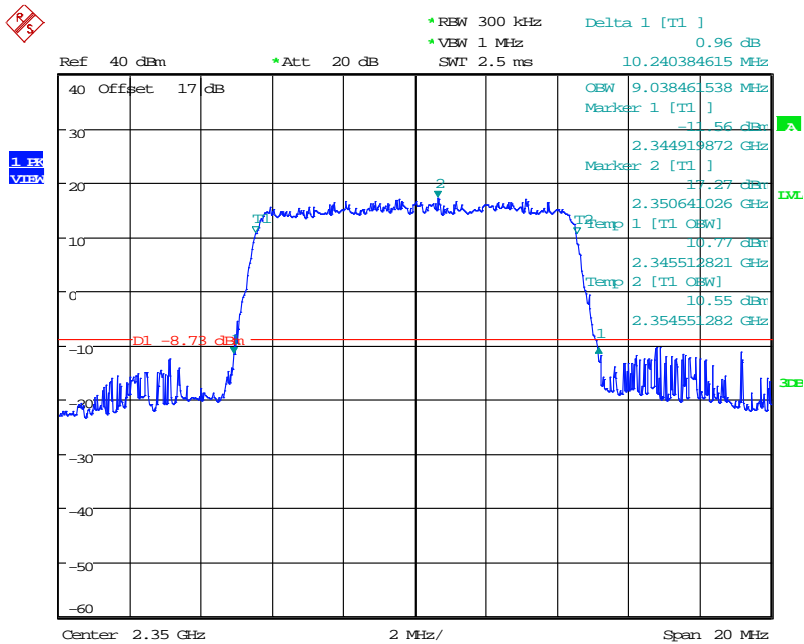

Date: 21.OCT.2024 17:46:50



Registration number: W6M22410-23833-C-247  
 FCC ID: GX9HYBLI  
 16QAM  
 12RB

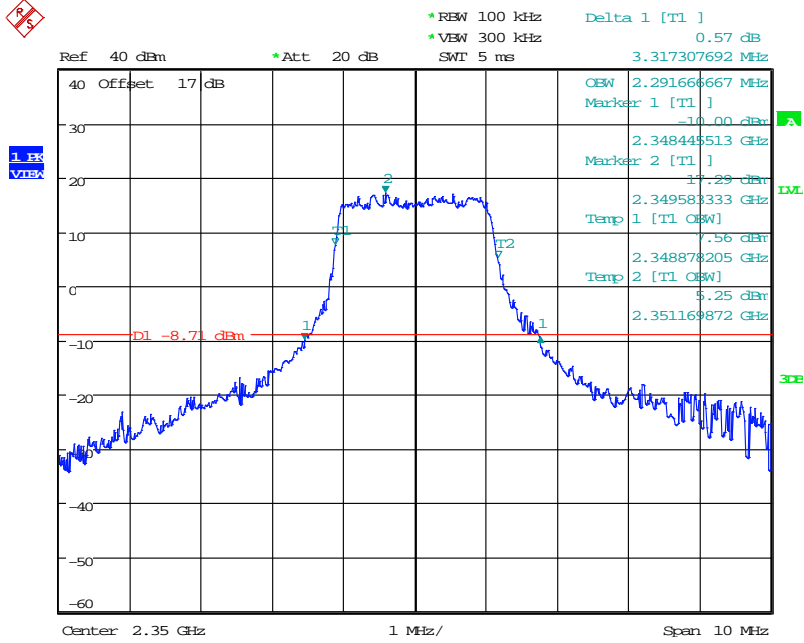

Date: 21.OCT.2024 17:45:24

15 MHz  
 QPSK  
 FRB

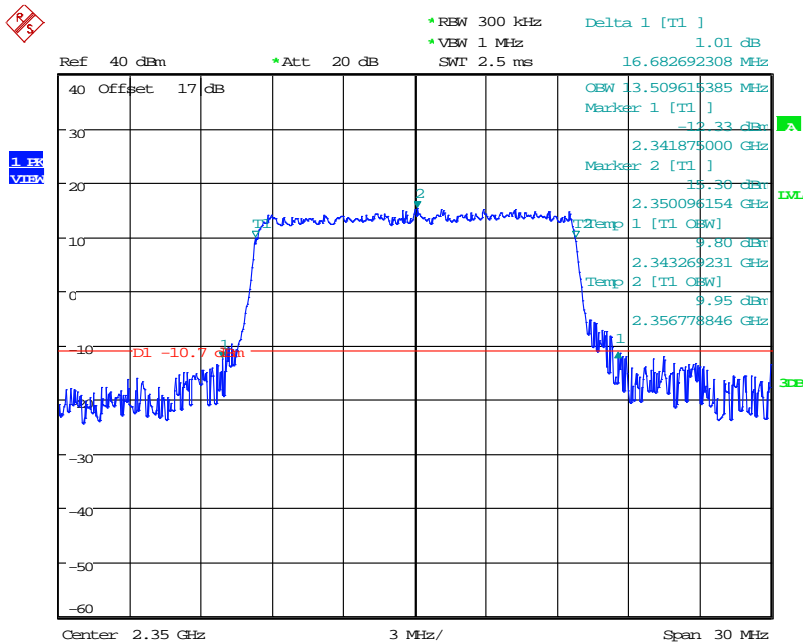

Date: 21.OCT.2024 18:04:55



Registration number: W6M22410-23833-C-247  
 FCC ID: GX9HYBLI  
 16QAM  
 18RB

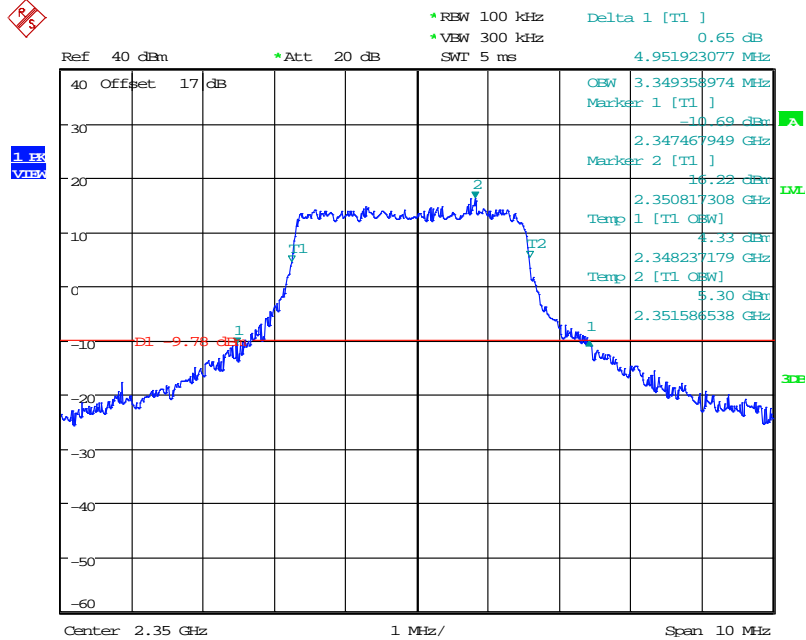

Date: 21.OCT.2024 18:06:50

20 MHz  
 QPSK  
 FRB

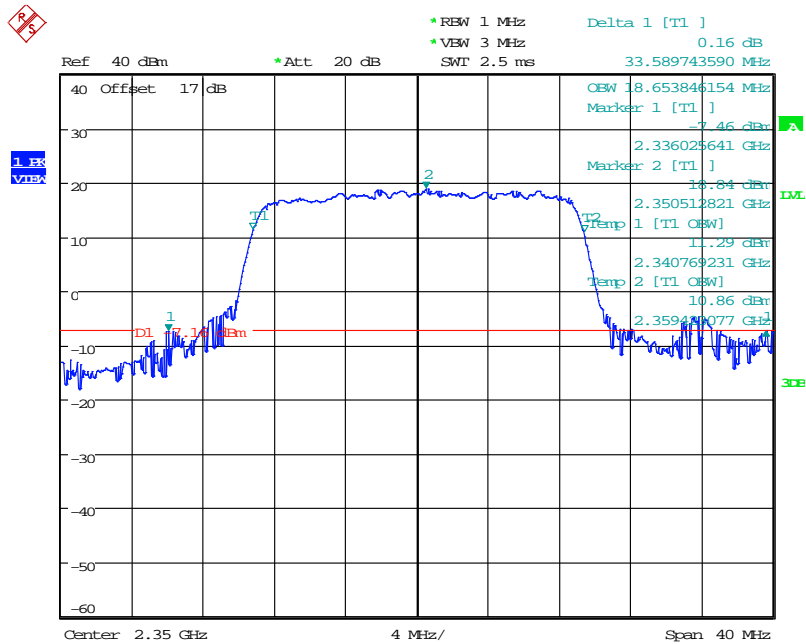

Date: 22.OCT.2024 08:02:12



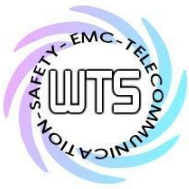

# Worldwide Testing Services(Taiwan) Co., Ltd.

Registration number: W6M22410-23833-C-247

FCC ID: GX9HYBLI

16QAM

18RB

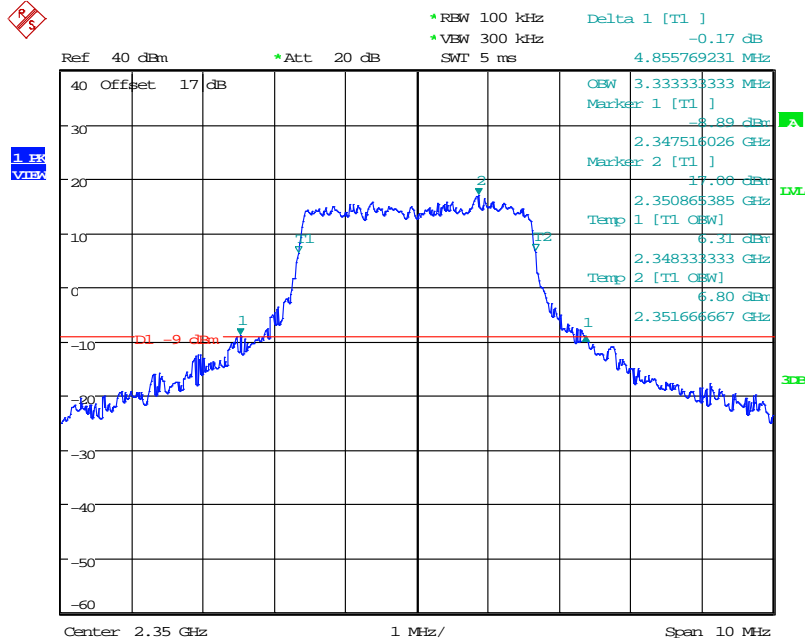

Date: 21.OCT.2024 18:21:07

Registration number: W6M22410-23833-C-247

FCC ID: GX9HYBLI

**7 Spurious Emissions at Antenna Terminals**

**7.1 Test procedure**

This transmitter output was connected to a calibrated coaxial attenuator, the other end of which was connected to a spectrum analyzer via a three-port splitter. Please refer to the following figure. Transmitter output was derived with the spectrum analyzer in dBm.

The Spurious Emissions at Antenna Terminals was measured by the spectrum analyzer with a suitable notch filter and/or Band-pass filter.

Tests were performed with an unmodulated carrier at three frequencies (low, middle and high channels ) and on all power levels , which can be set-up on the transmitters.

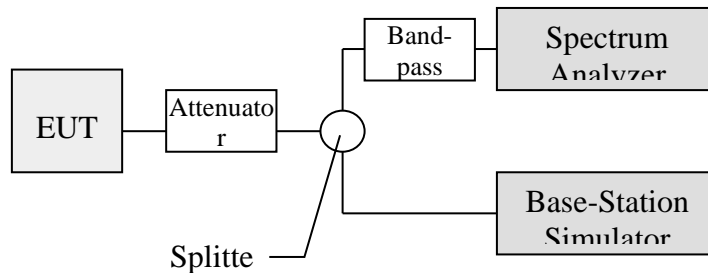

**7.2 Test Results**

Test date: October 21, 2024

Temperature: 24.5 °C

Humidity: 58.7 %

Tester: Sora

Band 2

1.4 MHz

QPSK

1RB

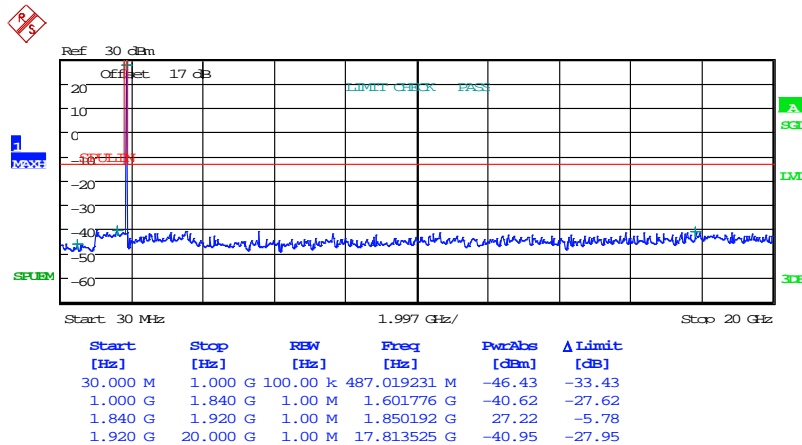



# Worldwide Testing Services(Taiwan) Co., Ltd.

Registration number: W6M22410-23833-C-247

FCC ID: GX9HYBLI

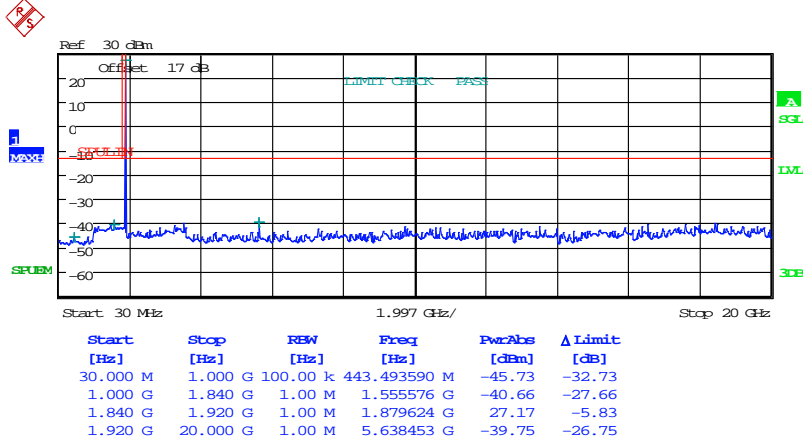

Date: 21.OCT.2024 14:15:38

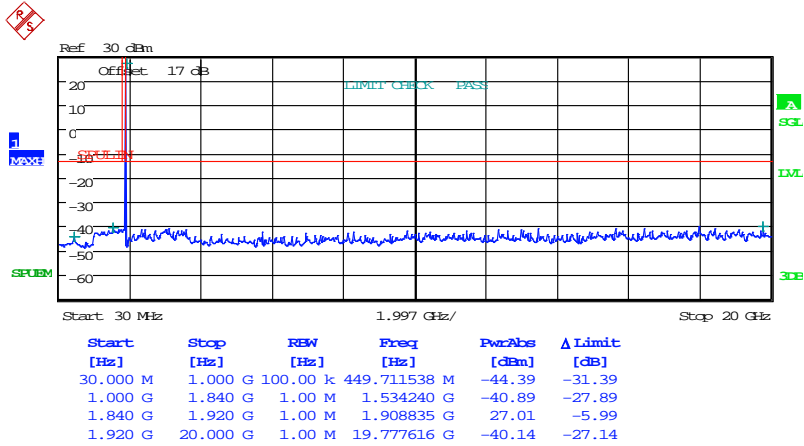

Date: 21.OCT.2024 14:16:11

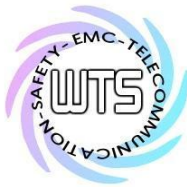

# Worldwide Testing Services(Taiwan) Co., Ltd.

Registration number: W6M22410-23833-C-247  
 FCC ID: GX9HYBLI  
 16QAM  
 1RB

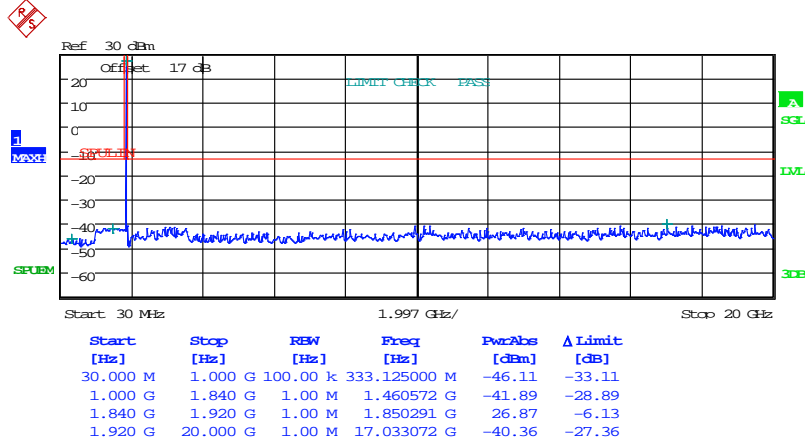

Date: 21.OCT.2024 14:17:12

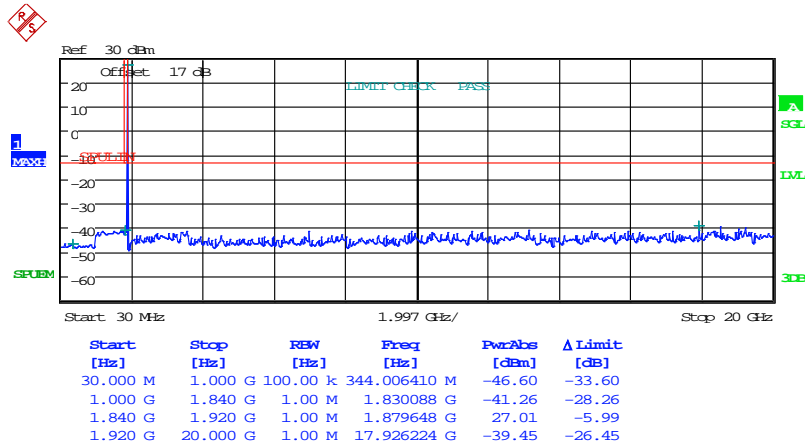

Date: 21.OCT.2024 14:17:26



Registration number: W6M22410-23833-C-247  
 FCC ID: GX9HYBLI

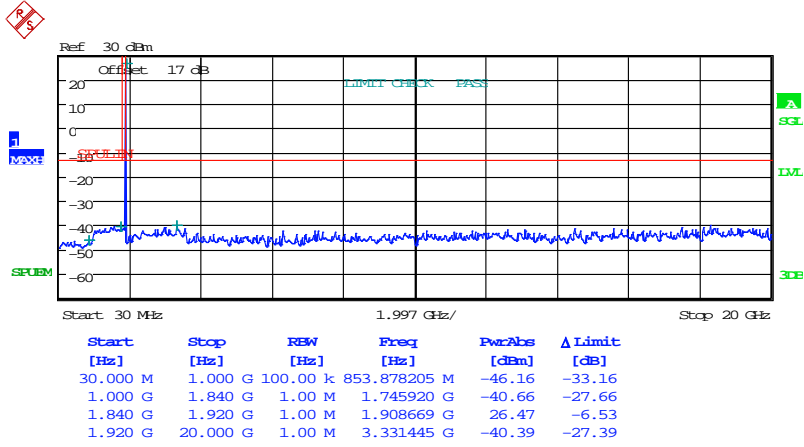

Date: 21.OCT.2024 14:16:55

3MHz  
 QPSK  
 1RB

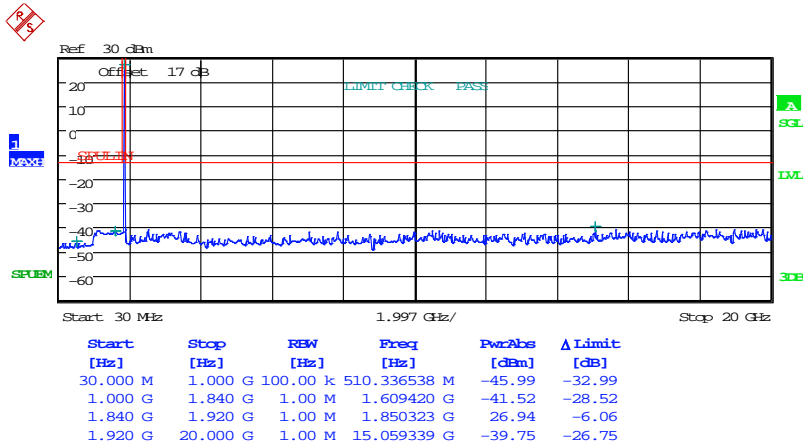

Date: 21.OCT.2024 14:20:21



Registration number: W6M22410-23833-C-247  
 FCC ID: GX9HYBLI

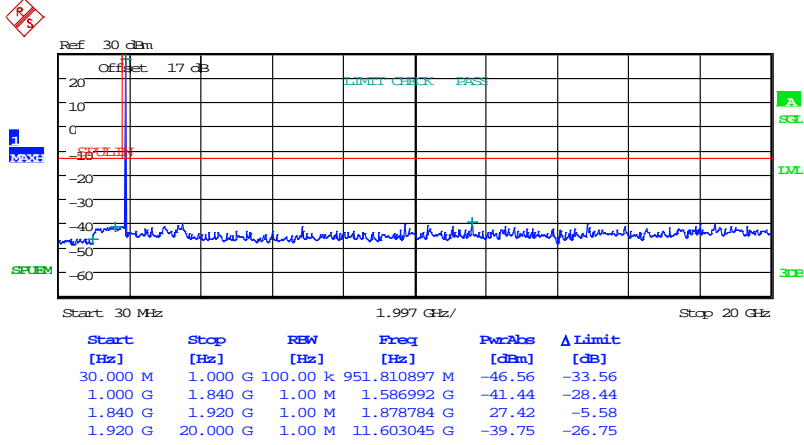

Date: 21.OCT.2024 14:20:34

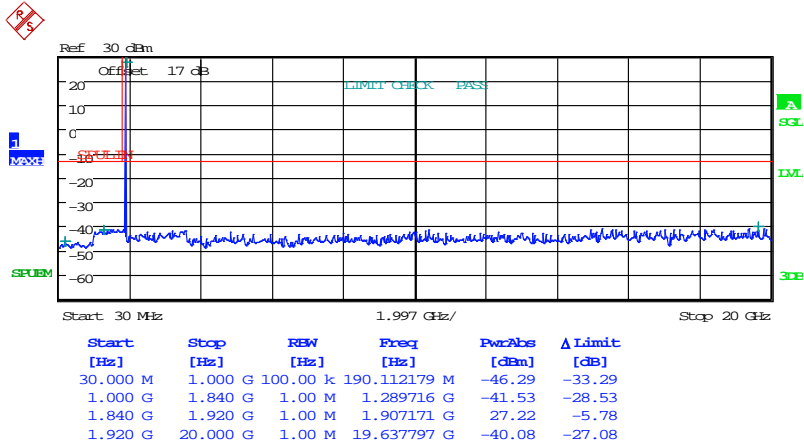

Date: 21.OCT.2024 14:19:58





# Worldwide Testing Services(Taiwan) Co., Ltd.

Registration number: W6M22410-23833-C-247

FCC ID: GX9HYBLI

16QAM

1RB

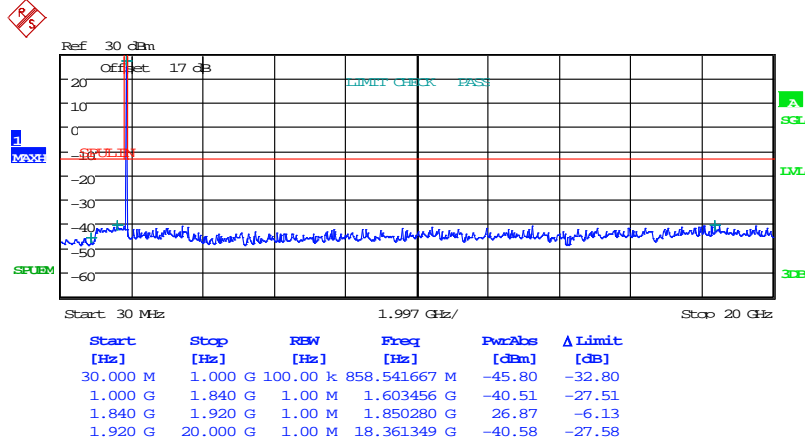

Date: 21.OCT.2024 14:19:18

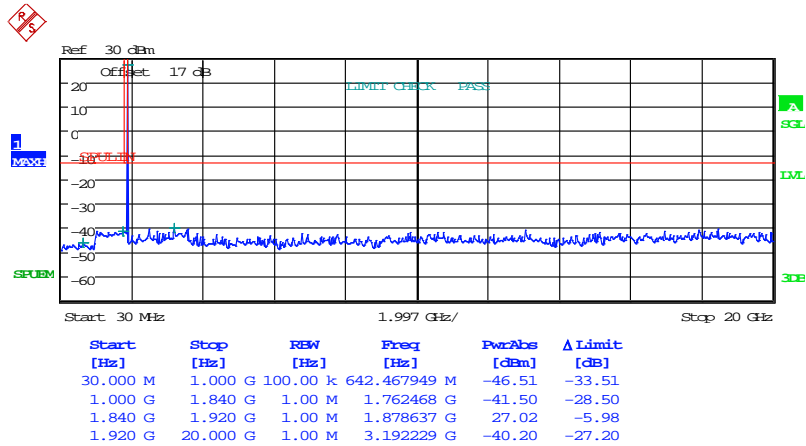

Date: 21.OCT.2024 14:18:59



# Worldwide Testing Services(Taiwan) Co., Ltd.

Registration number: W6M22410-23833-C-247  
 FCC ID: GX9HYBLI

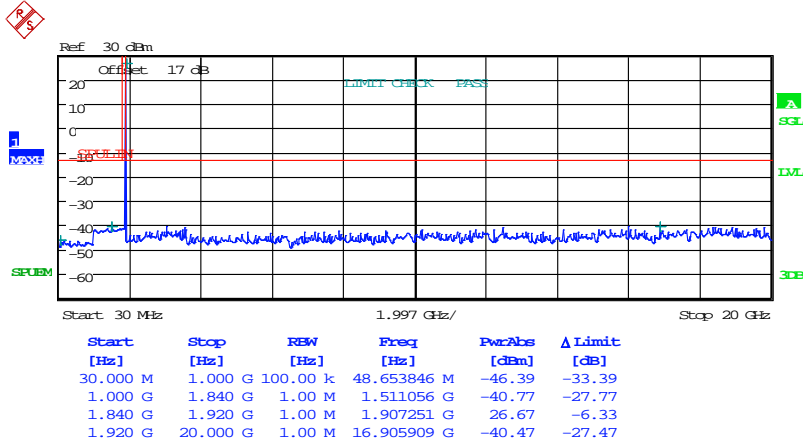

Date: 21.OCT.2024 14:19:36

5MHz  
 QPSK  
 1RB

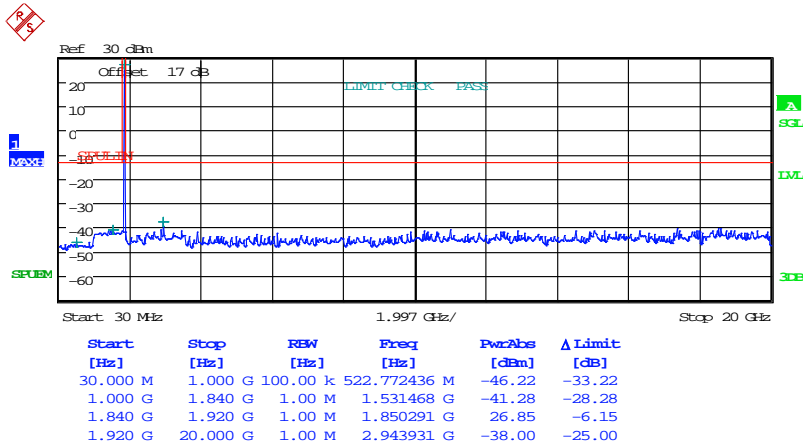

Date: 21.OCT.2024 14:21:22

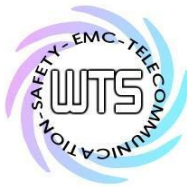

# Worldwide Testing Services(Taiwan) Co., Ltd.

Registration number: W6M22410-23833-C-247

FCC ID: GX9HYBLI

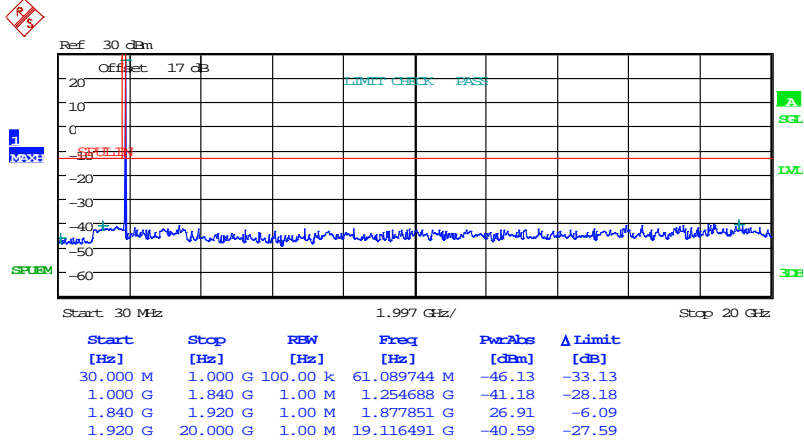

Date: 21.OCT.2024 14:21:01

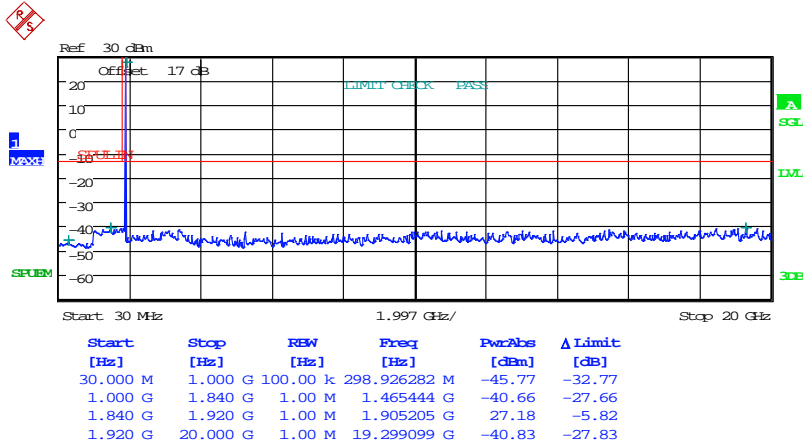

Date: 21.OCT.2024 14:22:16

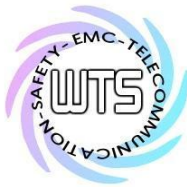

# Worldwide Testing Services(Taiwan) Co., Ltd.

Registration number: W6M22410-23833-C-247

FCC ID: GX9HYBLI

16QAM

1RB

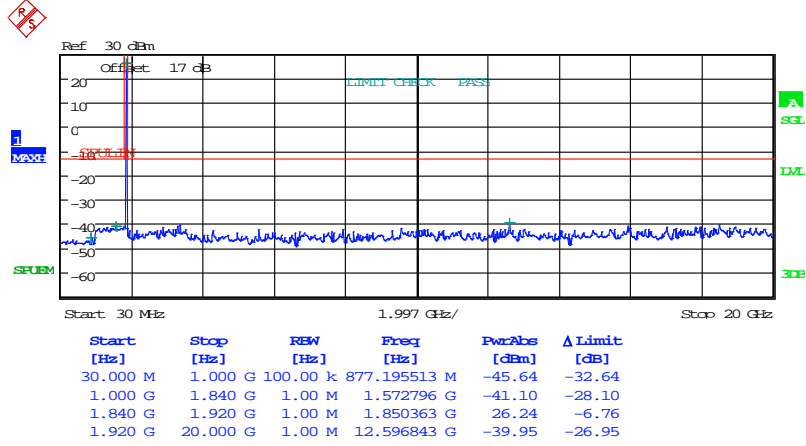

Date: 21.OCT.2024 14:23:18

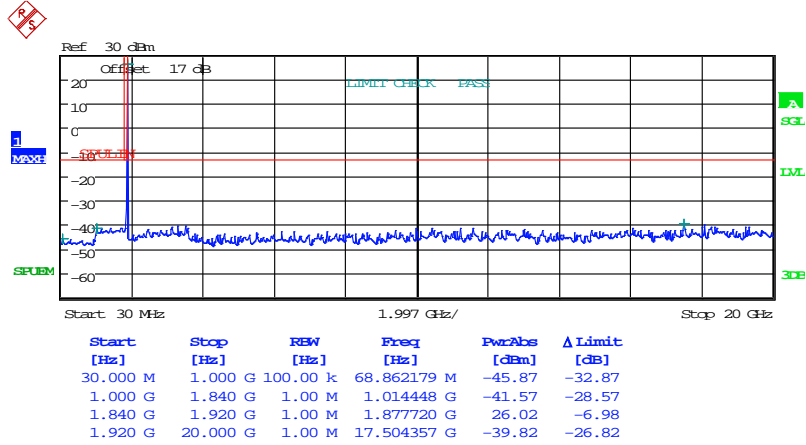

Date: 21.OCT.2024 14:23:36



# Worldwide Testing Services(Taiwan) Co., Ltd.

Registration number: W6M22410-23833-C-247

FCC ID: GX9HYBLI

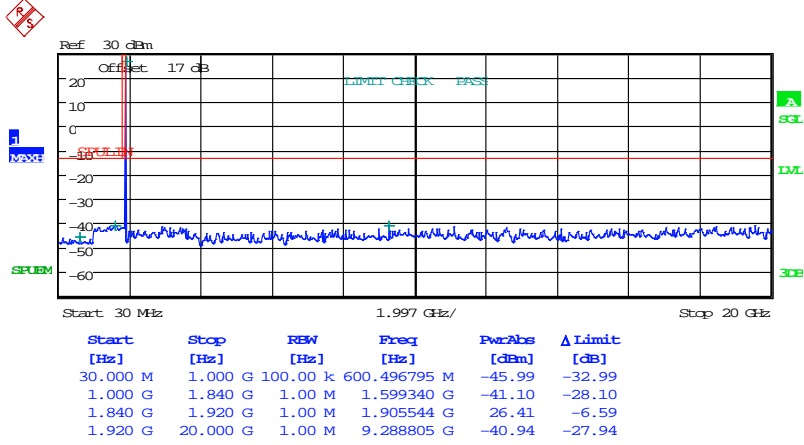

Date: 21.OCT.2024 14:22:45

10MHz  
QPSK  
1RB

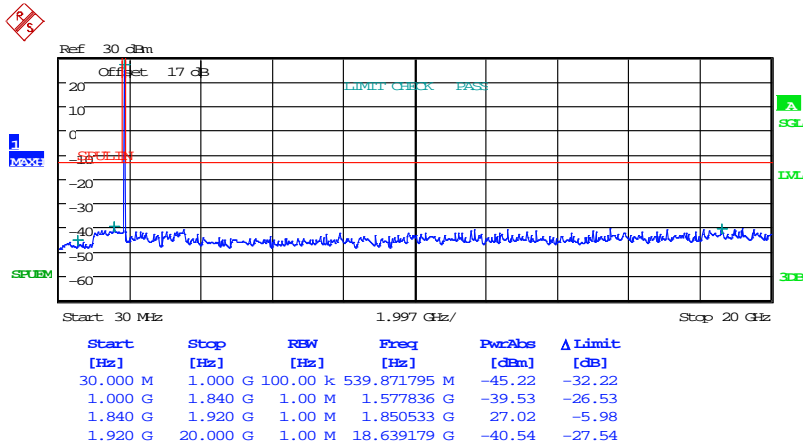

Date: 21.OCT.2024 14:25:26

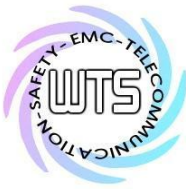

# Worldwide Testing Services(Taiwan) Co., Ltd.

Registration number: W6M22410-23833-C-247  
 FCC ID: GX9HYBLI

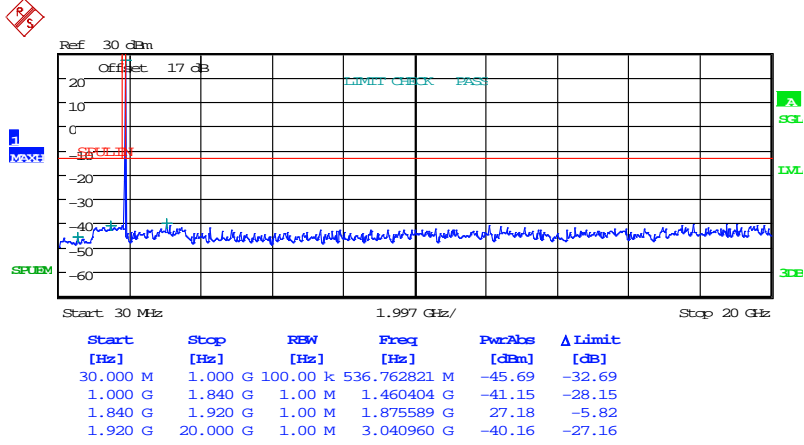

Date: 21.OCT.2024 14:25:59

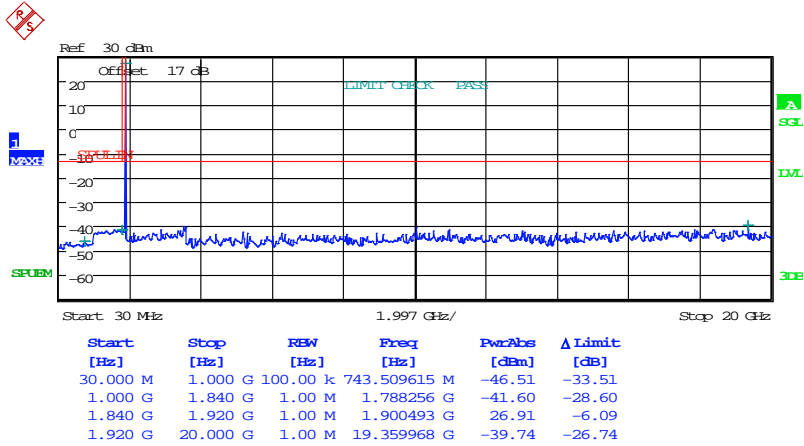

Date: 21.OCT.2024 14:25:07





# Worldwide Testing Services(Taiwan) Co., Ltd.

Registration number: W6M22410-23833-C-247  
 FCC ID: GX9HYBLI  
 16QAM  
 1RB

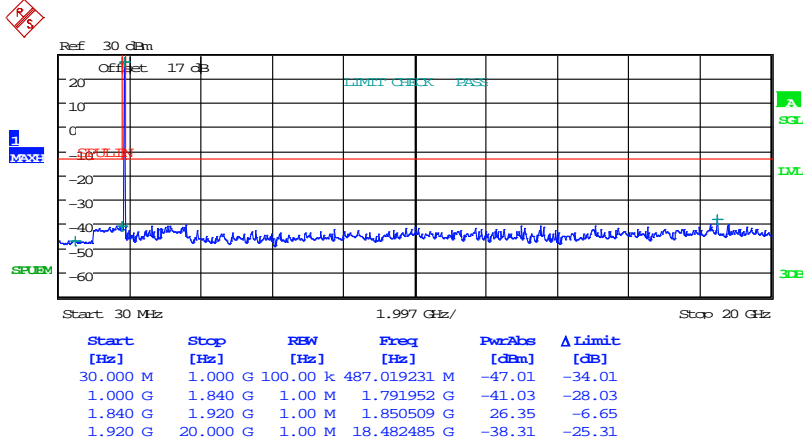

Date: 21.OCT.2024 14:24:20

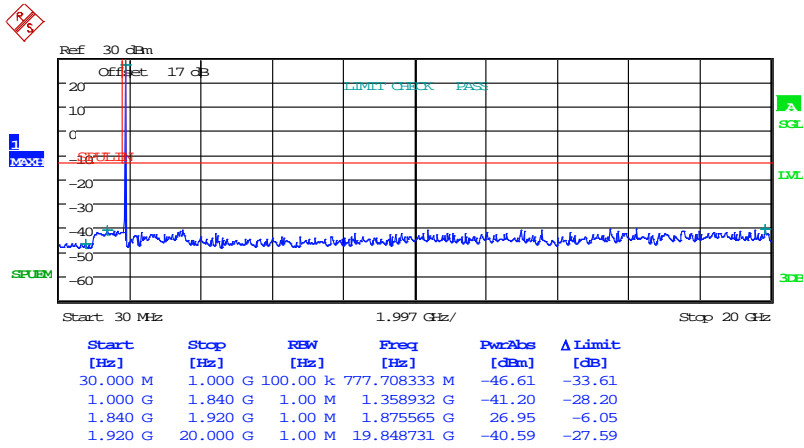

Date: 21.OCT.2024 14:24:05



Registration number: W6M22410-23833-C-247  
 FCC ID: GX9HYBLI

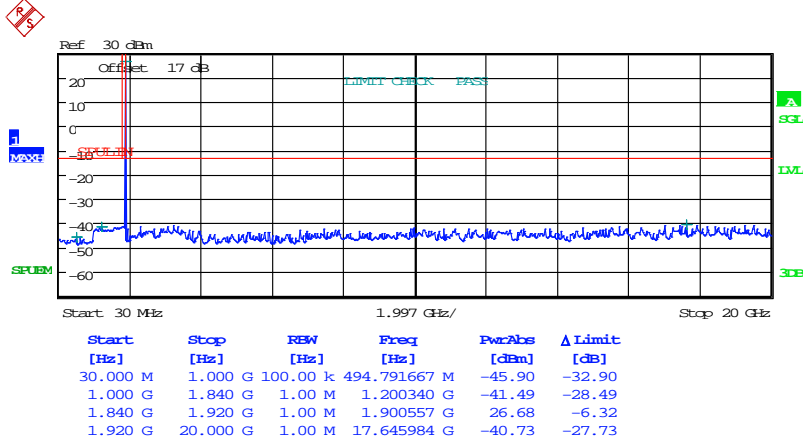

Date: 21.OCT.2024 14:24:39

15MHz  
 QPSK  
 1RB

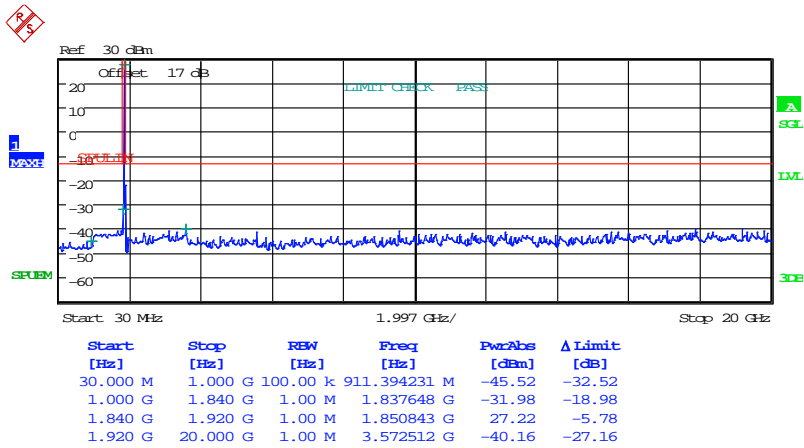

Date: 21.OCT.2024 14:27:00

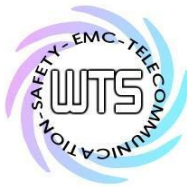

# Worldwide Testing Services(Taiwan) Co., Ltd.

Registration number: W6M22410-23833-C-247

FCC ID: GX9HYBLI

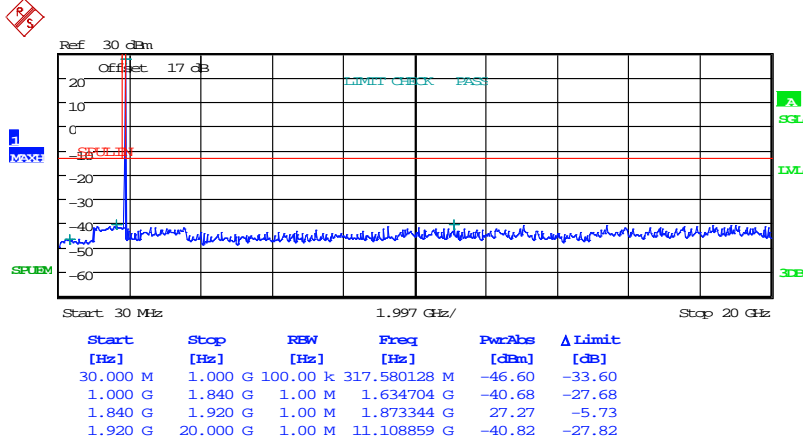

Date: 21.OCT.2024 14:26:27

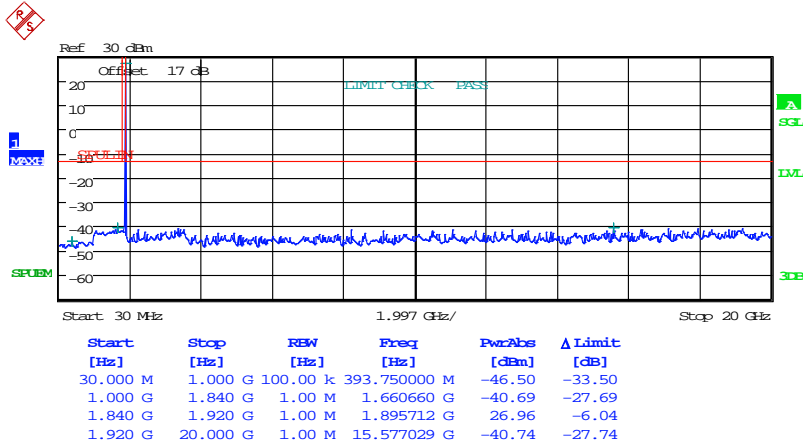

Date: 21.OCT.2024 14:27:26



# Worldwide Testing Services(Taiwan) Co., Ltd.

Registration number: W6M22410-23833-C-247  
 FCC ID: GX9HYBLI  
 16QAM  
 1RB

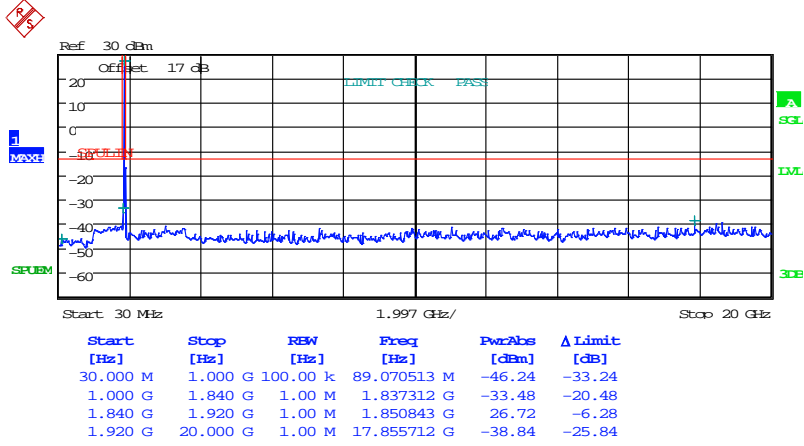

Date: 21.OCT.2024 13:55:47

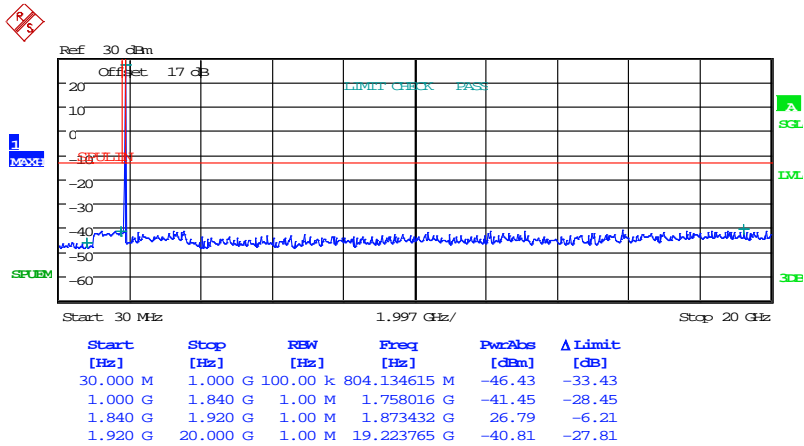

Date: 21.OCT.2024 13:55:25



# Worldwide Testing Services(Taiwan) Co., Ltd.

Registration number: W6M22410-23833-C-247

FCC ID: GX9HYBLI

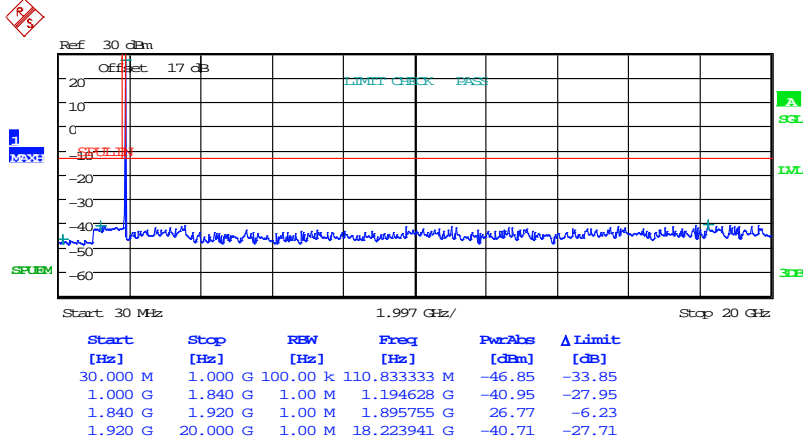

Date: 21.OCT.2024 13:57:13

20MHz  
QPSK  
1RB

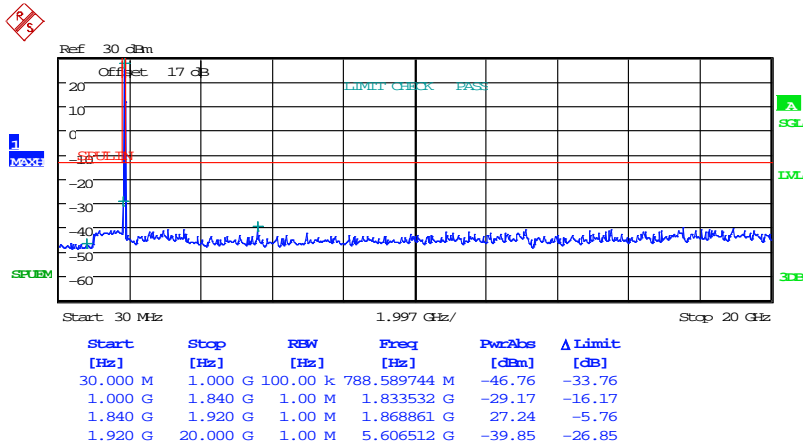

Date: 21.OCT.2024 13:50:18



# Worldwide Testing Services(Taiwan) Co., Ltd.

Registration number: W6M22410-23833-C-247  
 FCC ID: GX9HYBLI

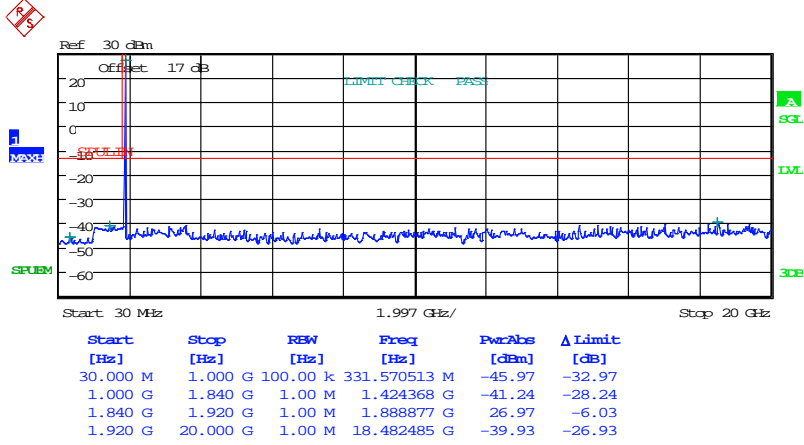

Date: 21.OCT.2024 13:50:42

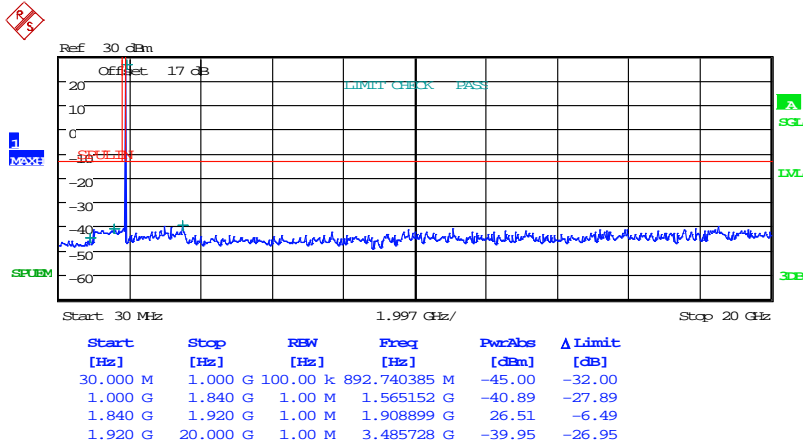

Date: 21.OCT.2024 13:51:14





# Worldwide Testing Services(Taiwan) Co., Ltd.

Registration number: W6M22410-23833-C-247

FCC ID: GX9HYBLI

16QAM

1RB

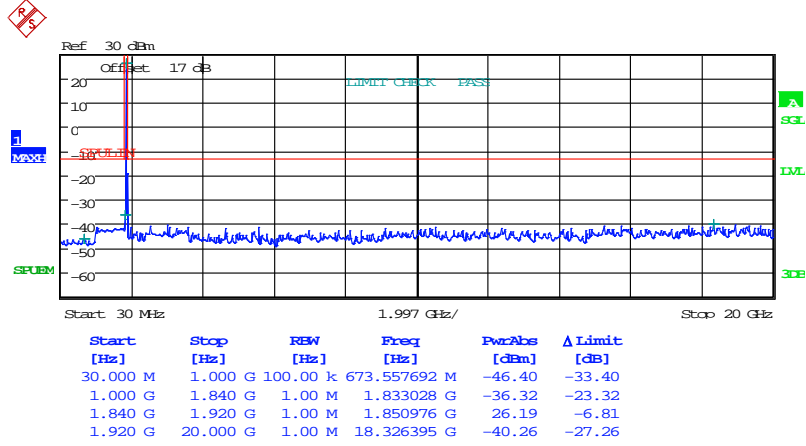

Date: 21.OCT.2024 13:54:52

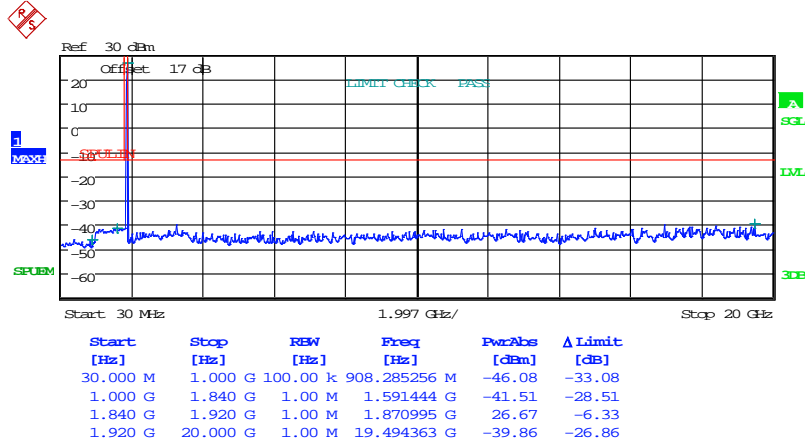

Date: 21.OCT.2024 13:51:54



Registration number: W6M22410-23833-C-247  
 FCC ID: GX9HYBLI

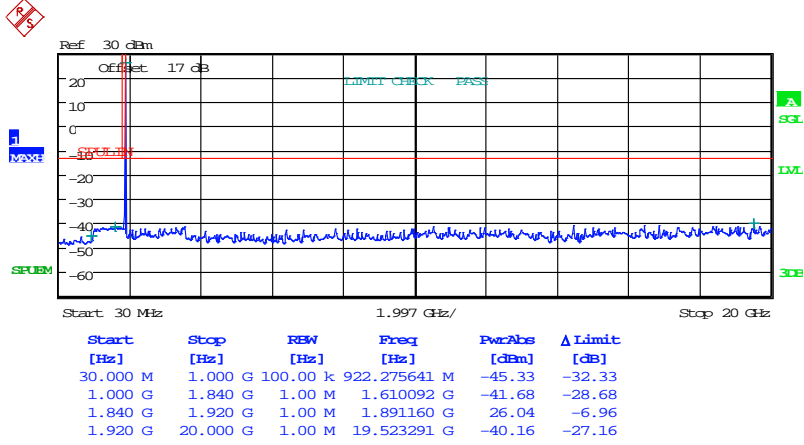

Date: 21.OCT.2024 13:51:38

Band 4  
 1.4MHz  
 QPSK  
 1RB

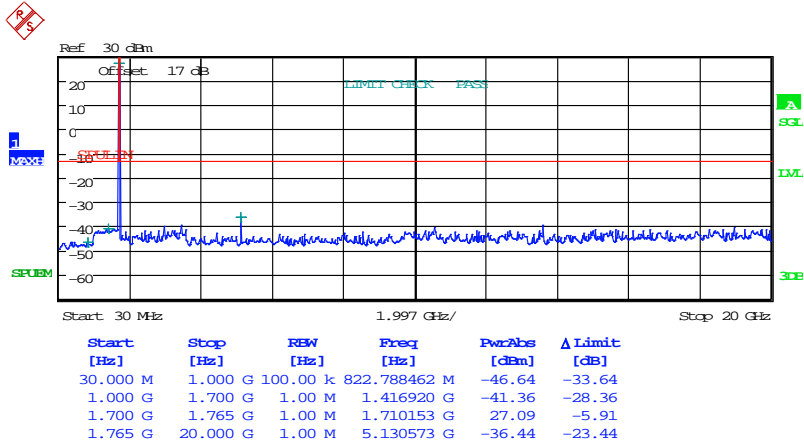

Date: 21.OCT.2024 14:38:48



# Worldwide Testing Services(Taiwan) Co., Ltd.

Registration number: W6M22410-23833-C-247  
 FCC ID: GX9HYBLI

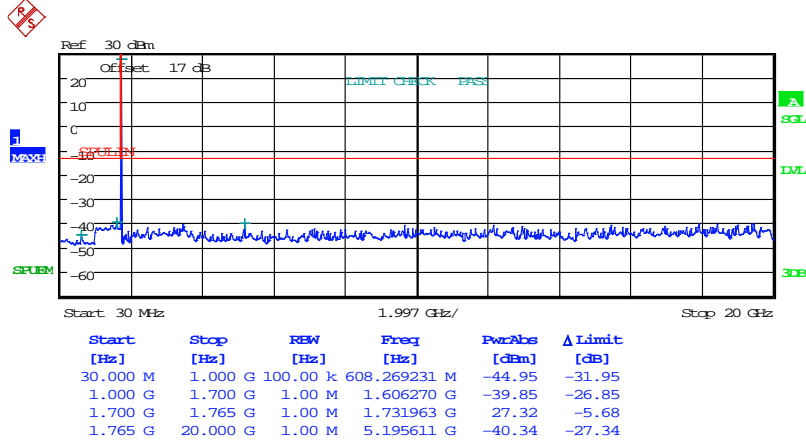

Date: 21.OCT.2024 14:38:31

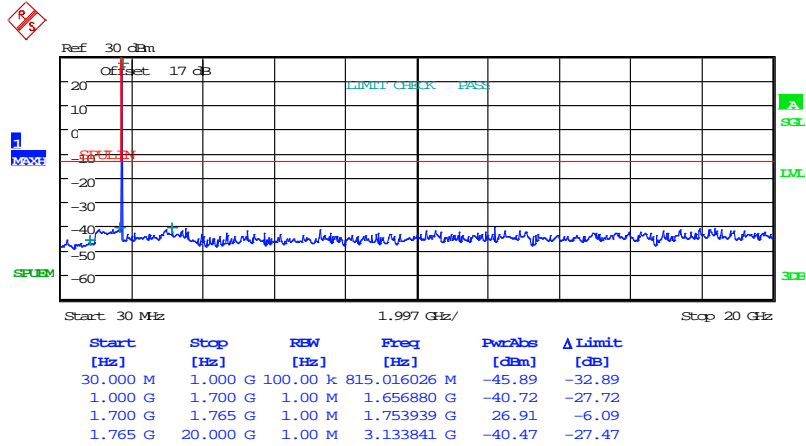

Date: 21.OCT.2024 14:39:10



# Worldwide Testing Services(Taiwan) Co., Ltd.

Registration number: W6M22410-23833-C-247  
 FCC ID: GX9HYBLI  
 16QAM  
 1RB

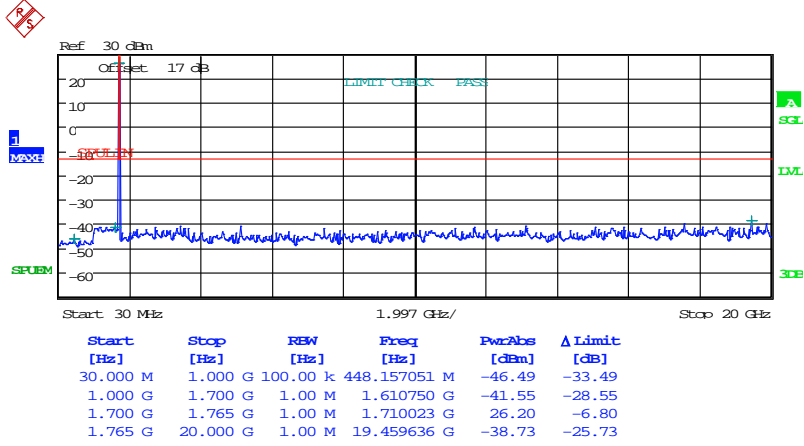

Date: 21.OCT.2024 14:39:50

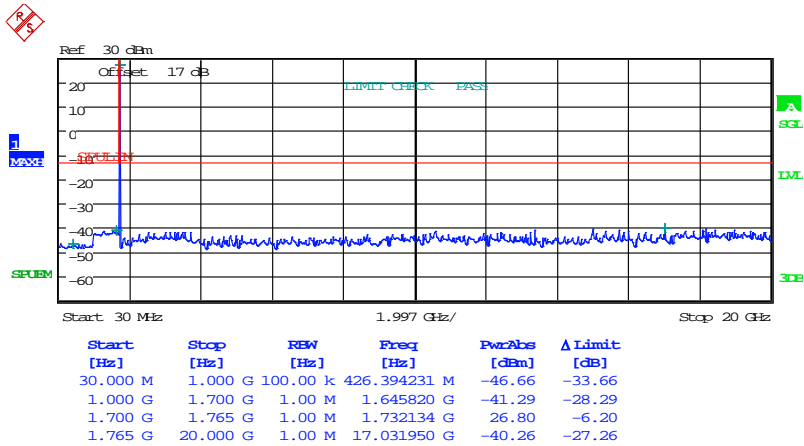

Date: 21.OCT.2024 14:40:05



Registration number: W6M22410-23833-C-247  
 FCC ID: GX9HYBLI

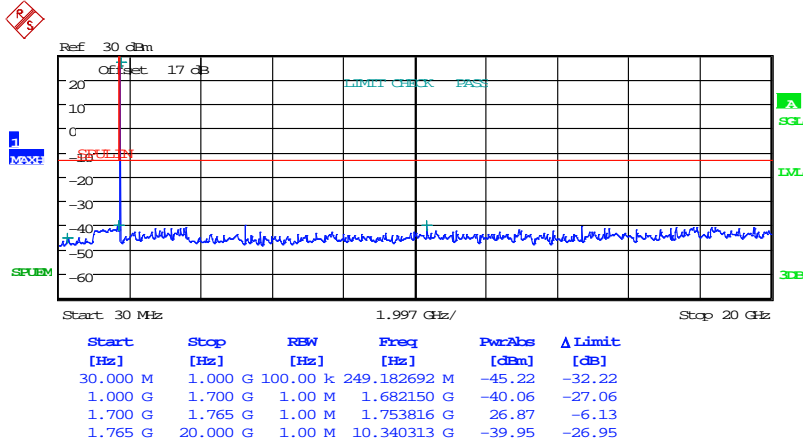

Date: 21.OCT.2024 14:39:33

3MHz  
 QPSK  
 1RB

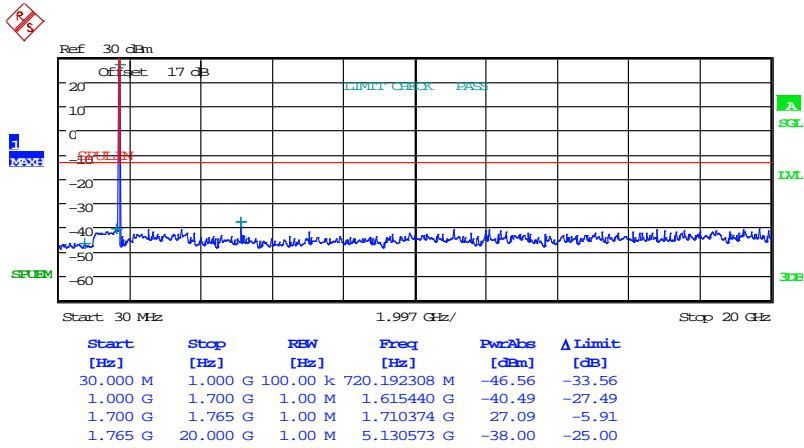

Date: 21.OCT.2024 14:45:10

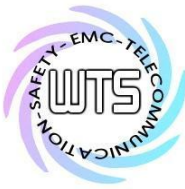

# Worldwide Testing Services(Taiwan) Co., Ltd.

Registration number: W6M22410-23833-C-247  
 FCC ID: GX9HYBLI

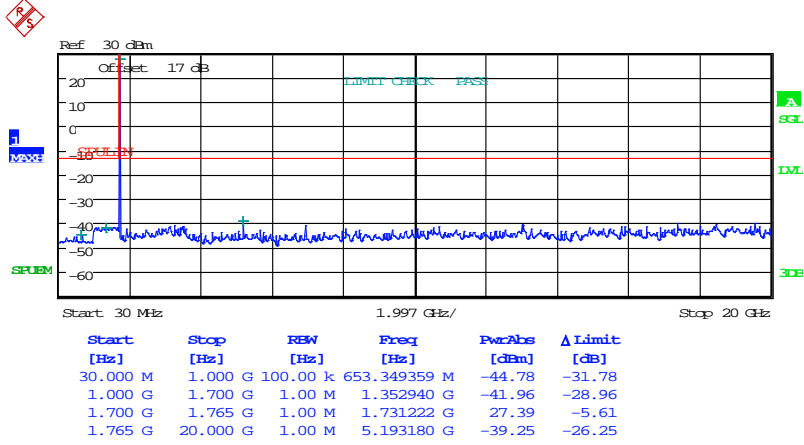

Date: 21.OCT.2024 14:45:41

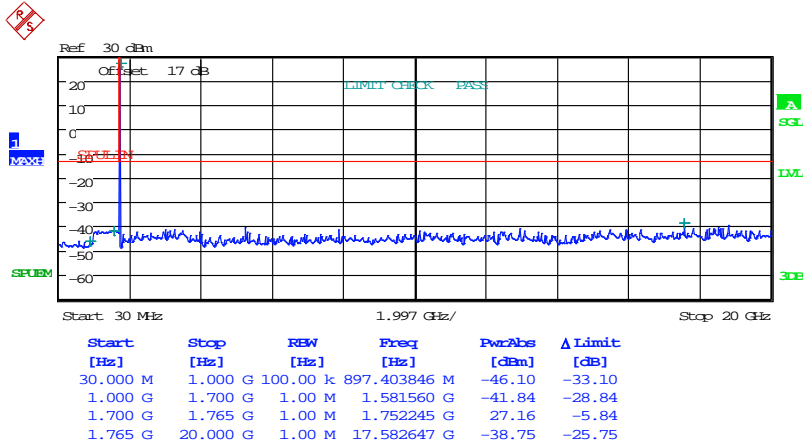

Date: 21.OCT.2024 14:44:49



# Worldwide Testing Services(Taiwan) Co., Ltd.

Registration number: W6M22410-23833-C-247  
 FCC ID: GX9HYBLI  
 16QAM  
 1RB

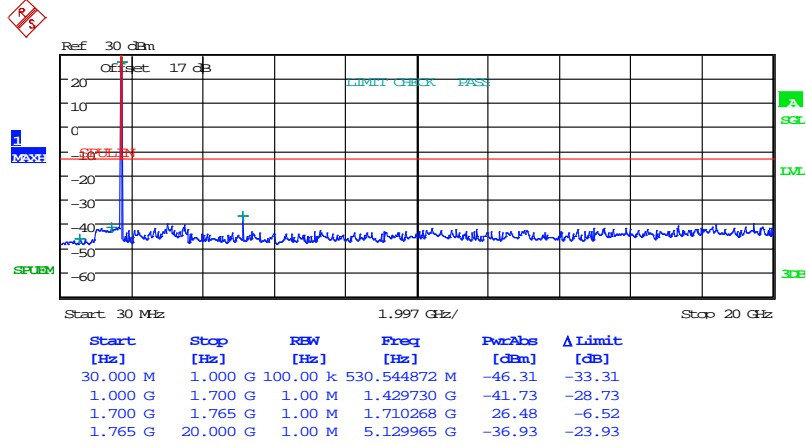

Date: 21.OCT.2024 14:44:00

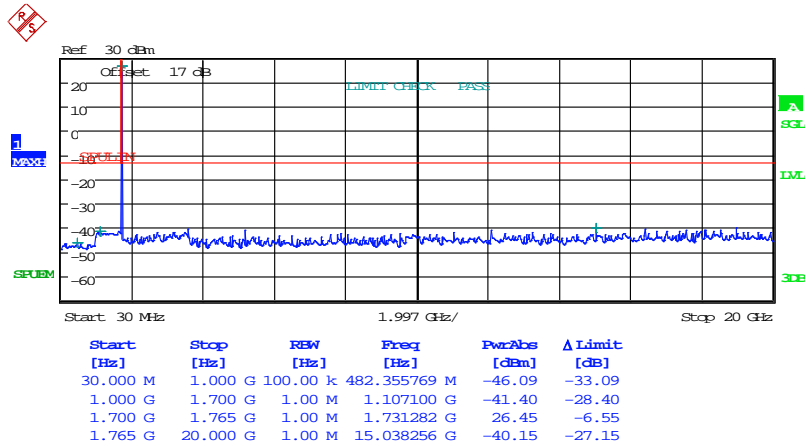

Date: 21.OCT.2024 14:43:32



# Worldwide Testing Services(Taiwan) Co., Ltd.

Registration number: W6M22410-23833-C-247  
 FCC ID: GX9HYBLI

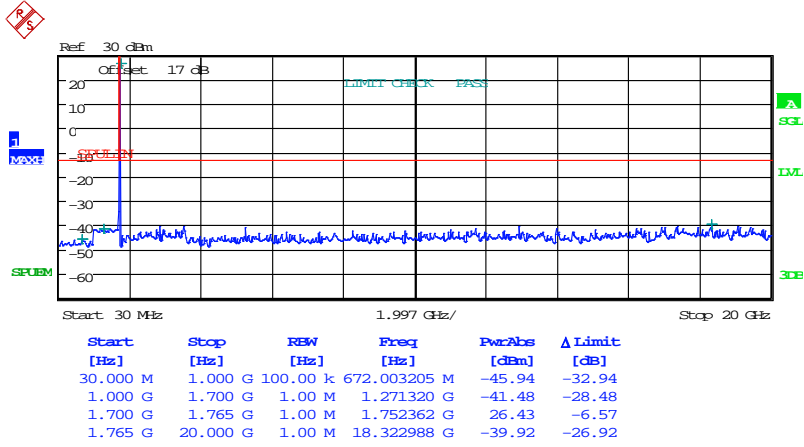

Date: 21.OCT.2024 14:44:29

5MHz  
 QPSK  
 1RB

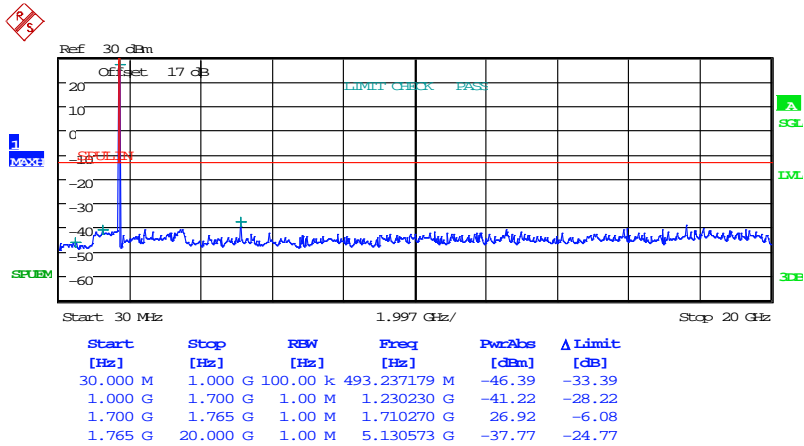

Date: 21.OCT.2024 14:46:59





# Worldwide Testing Services(Taiwan) Co., Ltd.

Registration number: W6M22410-23833-C-247  
 FCC ID: GX9HYBLI

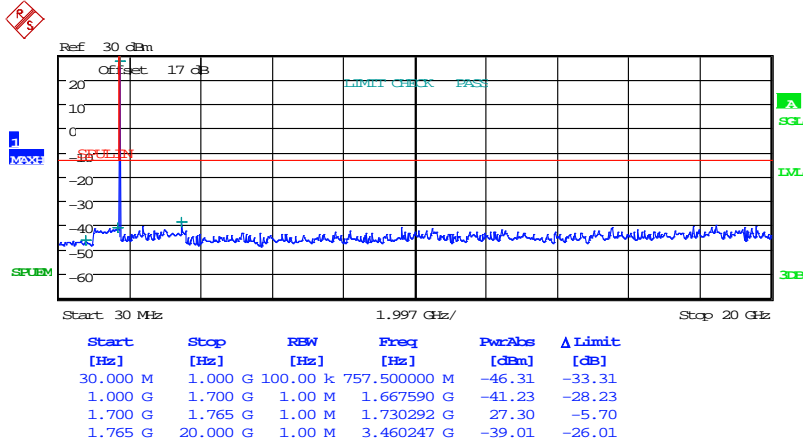

Date: 21.OCT.2024 14:46:06

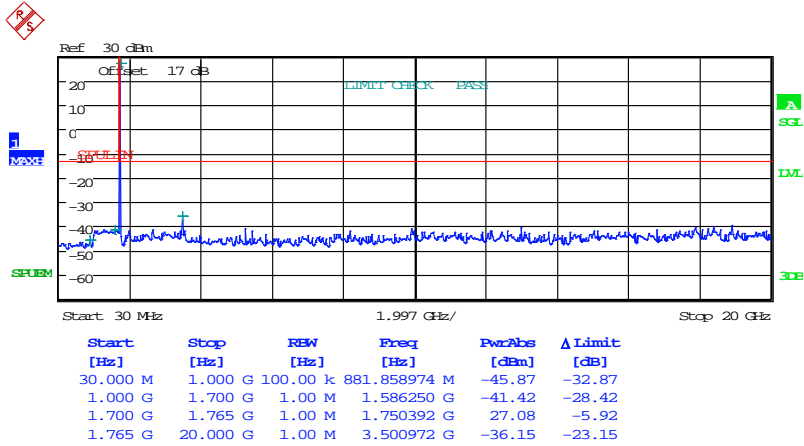

Date: 21.OCT.2024 14:47:22



# Worldwide Testing Services(Taiwan) Co., Ltd.

Registration number: W6M22410-23833-C-247  
 FCC ID: GX9HYBLI  
 16QAM  
 1RB

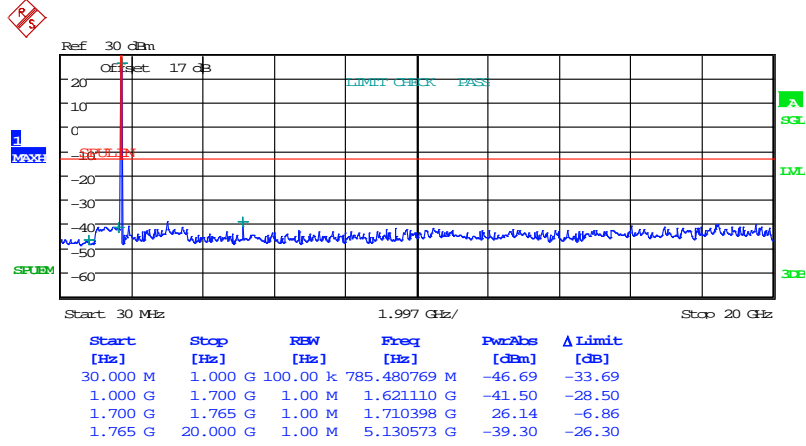

Date: 21.OCT.2024 14:48:30

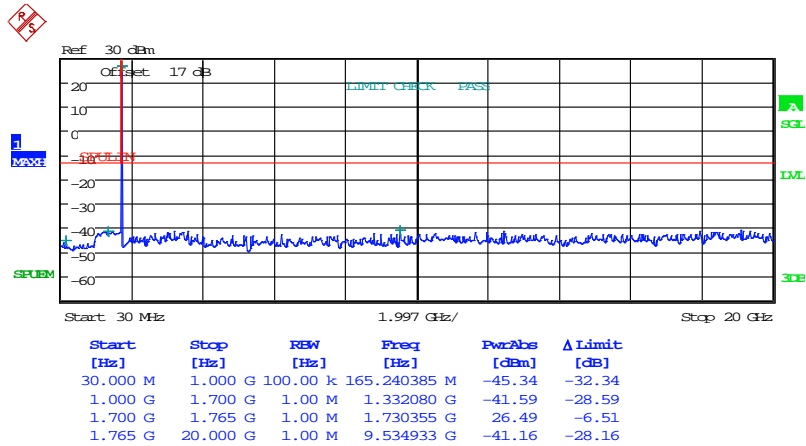

Date: 21.OCT.2024 14:48:59



Registration number: W6M22410-23833-C-247  
 FCC ID: GX9HYBLI

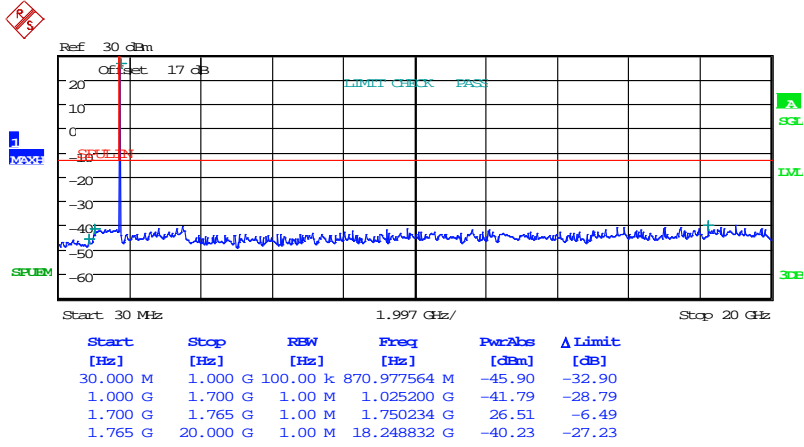

Date: 21.OCT.2024 14:48:10

10MHz  
 QPSK  
 1RB

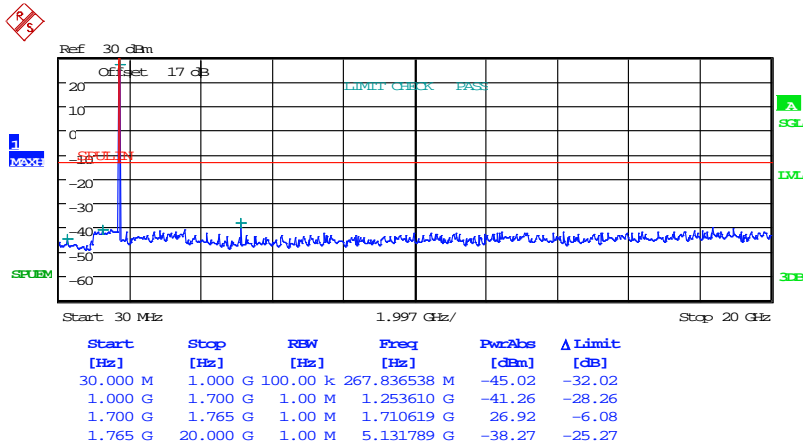

Date: 21.OCT.2024 14:51:20



# Worldwide Testing Services(Taiwan) Co., Ltd.

Registration number: W6M22410-23833-C-247

FCC ID: GX9HYBLI

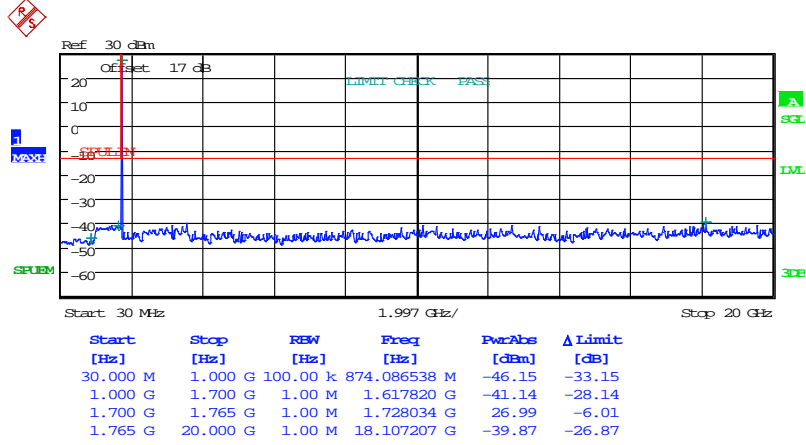

Date: 21.OCT.2024 14:51:42

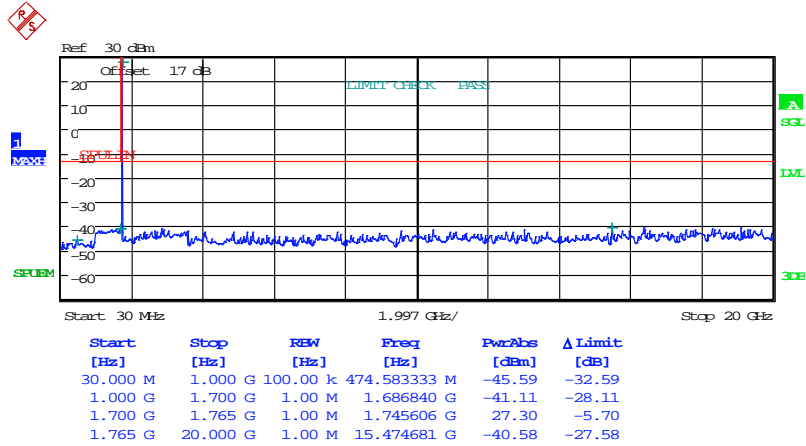

Date: 21.OCT.2024 14:50:55



# Worldwide Testing Services(Taiwan) Co., Ltd.

Registration number: W6M22410-23833-C-247

FCC ID: GX9HYBLI

16QAM

1RB

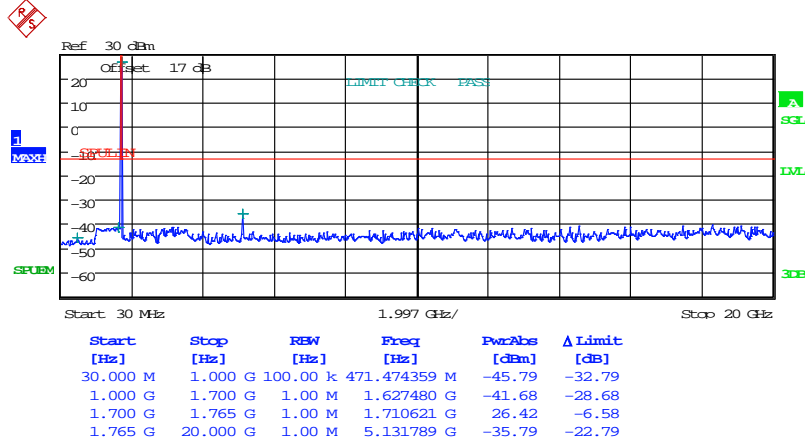

Date: 21.OCT.2024 14:50:05

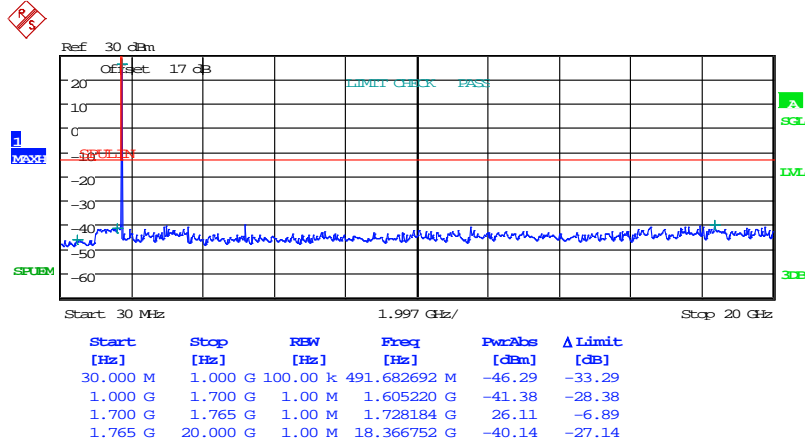

Date: 21.OCT.2024 14:49:35

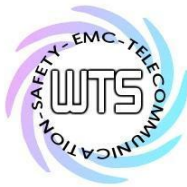

Registration number: W6M22410-23833-C-247  
 FCC ID: GX9HYBLI

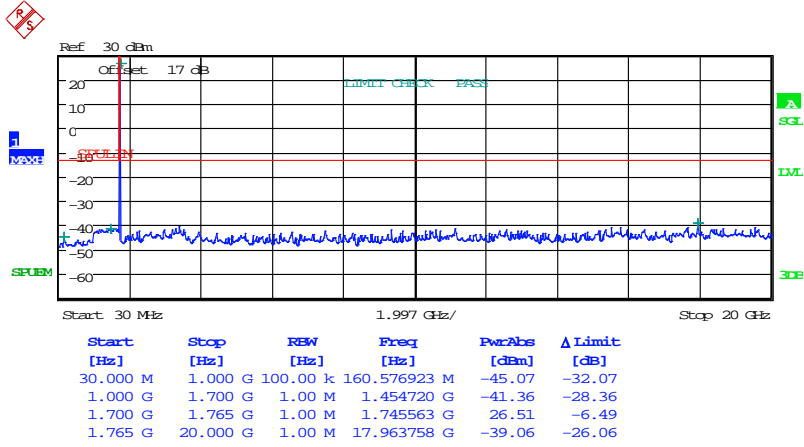

Date: 21.OCT.2024 14:50:32

15MHz  
 QPSK  
 1RB

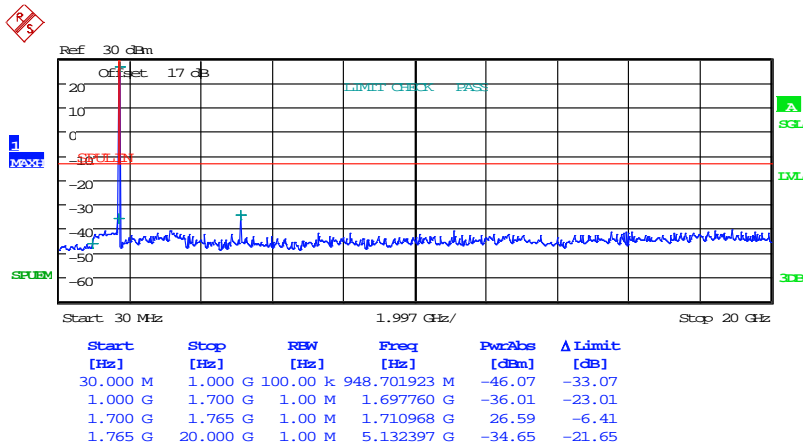

Date: 21.OCT.2024 14:52:33

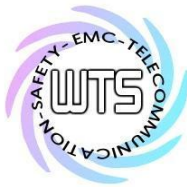

# Worldwide Testing Services(Taiwan) Co., Ltd.

Registration number: W6M22410-23833-C-247

FCC ID: GX9HYBLI

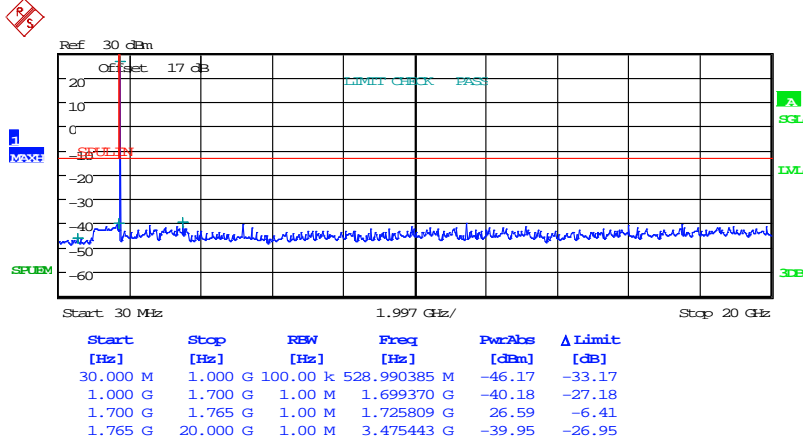

Date: 21.OCT.2024 14:52:12

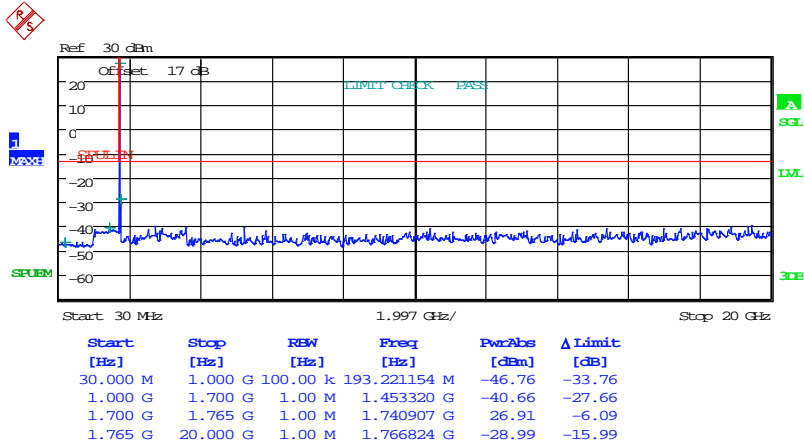

Date: 21.OCT.2024 14:53:03



# Worldwide Testing Services(Taiwan) Co., Ltd.

Registration number: W6M22410-23833-C-247  
 FCC ID: GX9HYBLI  
 16QAM  
 1RB

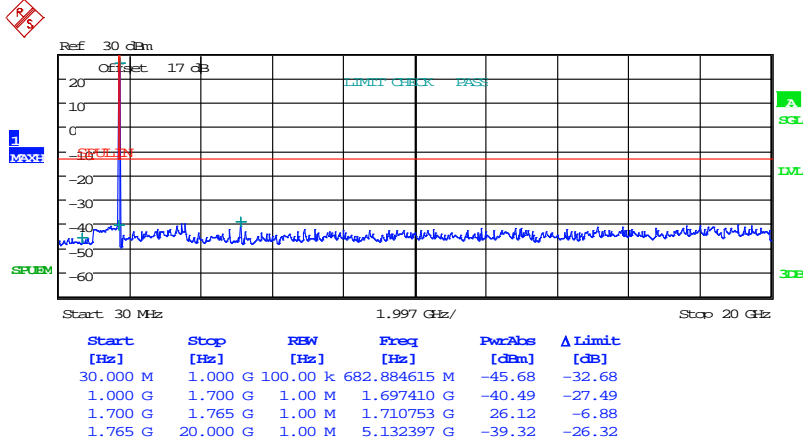

Date: 21.OCT.2024 14:53:42

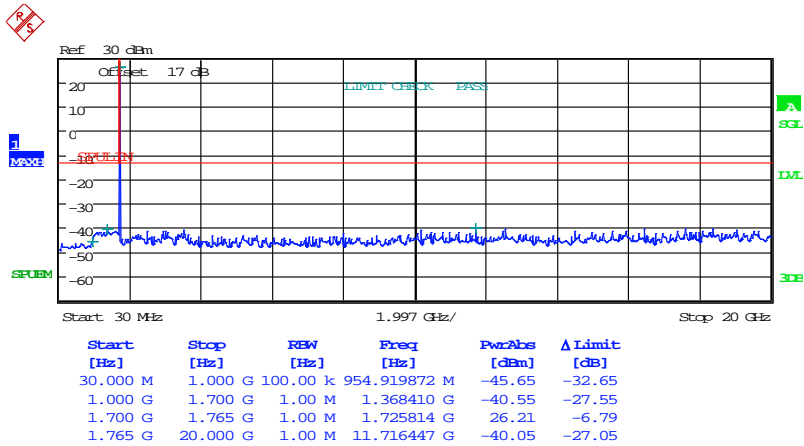

Date: 21.OCT.2024 14:54:02





# Worldwide Testing Services(Taiwan) Co., Ltd.

Registration number: W6M22410-23833-C-247  
 FCC ID: GX9HYBLI

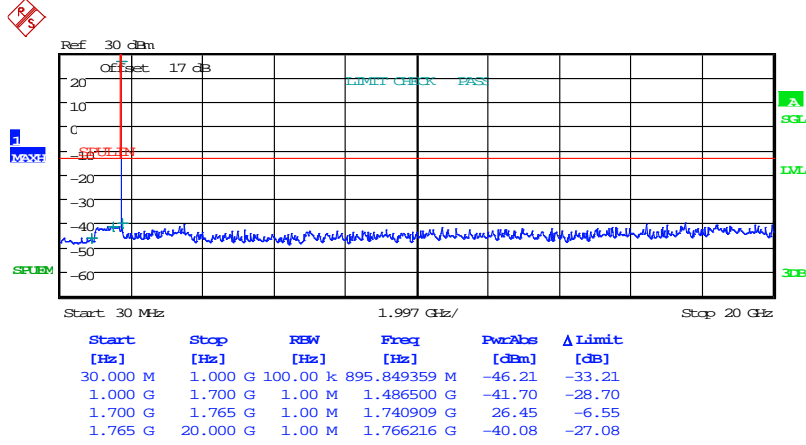

Date: 21.OCT.2024 14:53:27

20MHz  
 QPSK  
 1RB

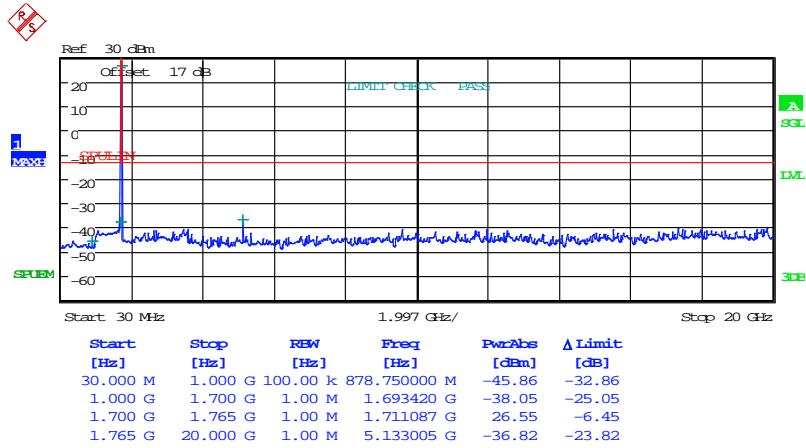

Date: 21.OCT.2024 14:55:54



# Worldwide Testing Services(Taiwan) Co., Ltd.

Registration number: W6M22410-23833-C-247  
 FCC ID: GX9HYBLI

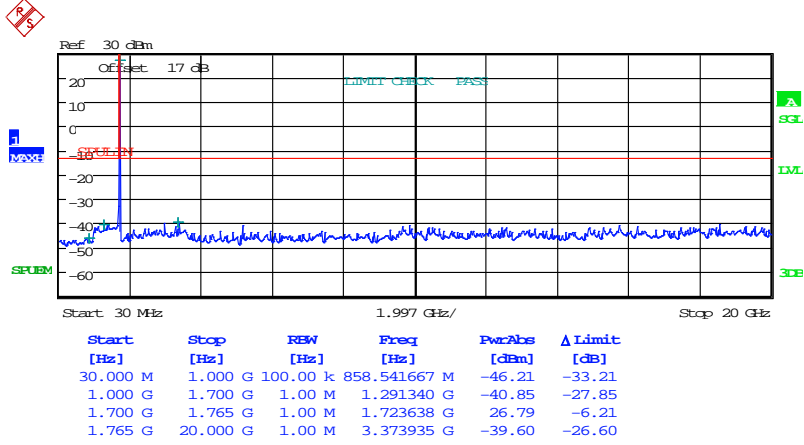

Date: 21.OCT.2024 14:56:27

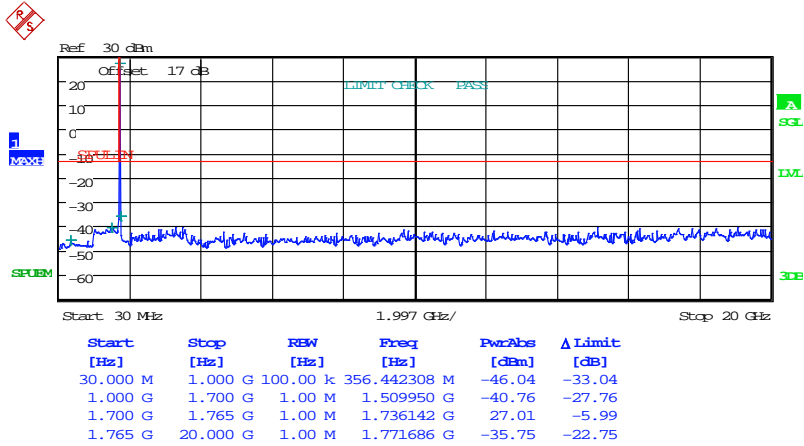

Date: 21.OCT.2024 14:55:40



# Worldwide Testing Services(Taiwan) Co., Ltd.

Registration number: W6M22410-23833-C-247  
 FCC ID: GX9HYBLI  
 16QAM  
 1RB

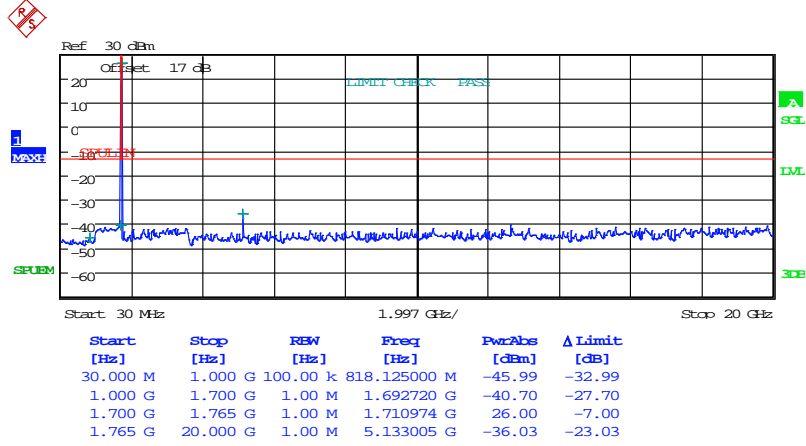

Date: 21.OCT.2024 14:54:53

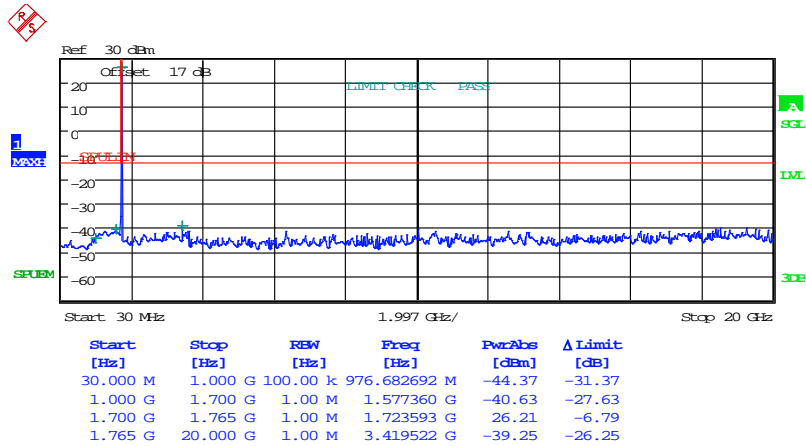

Date: 21.OCT.2024 14:54:37

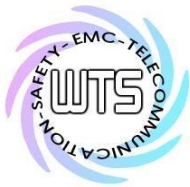

Registration number: W6M22410-23833-C-247  
 FCC ID: GX9HYBLI

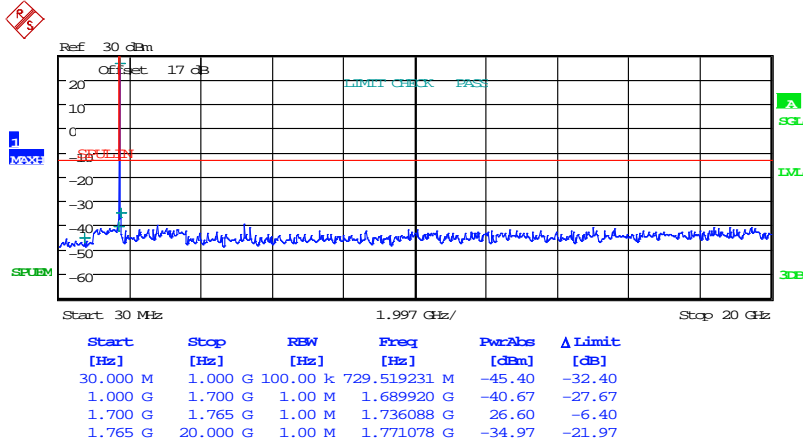

Date: 21.OCT.2024 14:55:12

Band 5  
 1.4MHz  
 QPSK  
 1RB

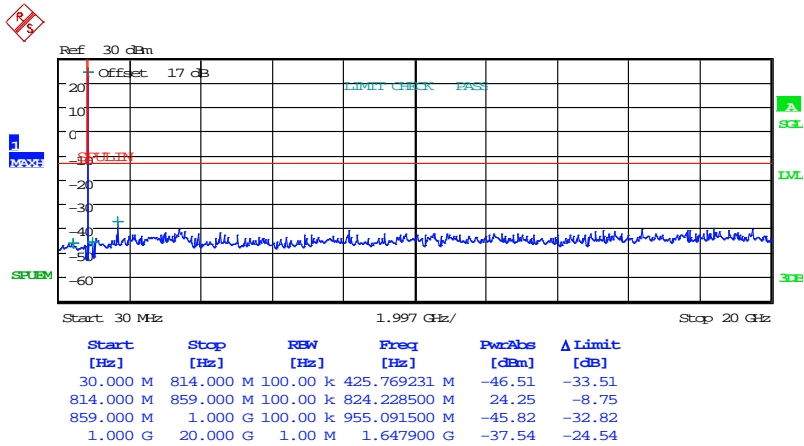

Date: 21.OCT.2024 15:03:43

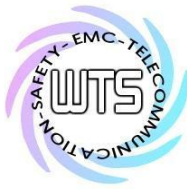

# Worldwide Testing Services(Taiwan) Co., Ltd.

Registration number: W6M22410-23833-C-247

FCC ID: GX9HYBLI

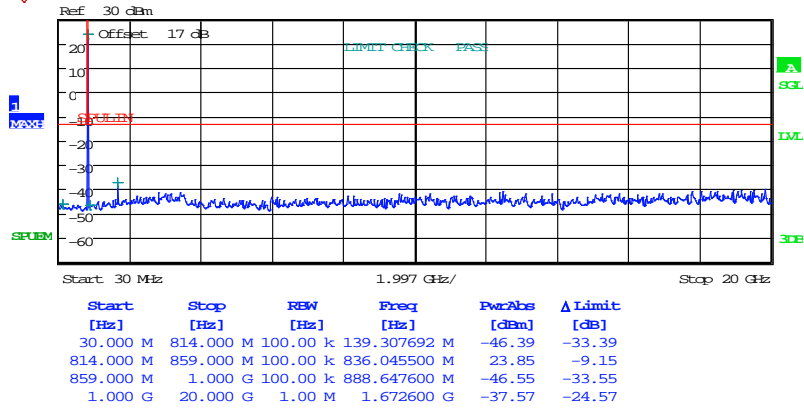

Date: 21.OCT.2024 15:03:24

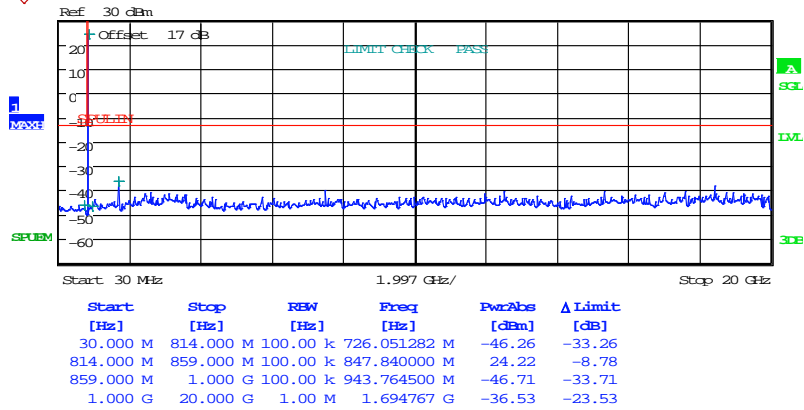

Date: 21.OCT.2024 15:03:58



# Worldwide Testing Services(Taiwan) Co., Ltd.

Registration number: W6M22410-23833-C-247  
 FCC ID: GX9HYBLI  
 16QAM  
 1RB

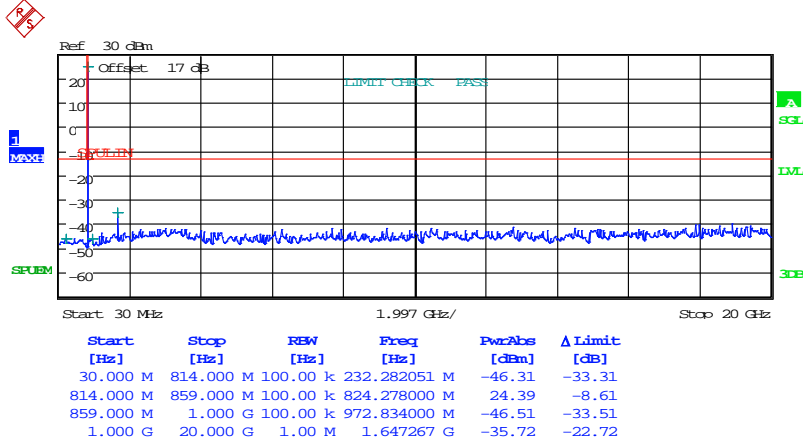

Date: 21.OCT.2024 15:04:36

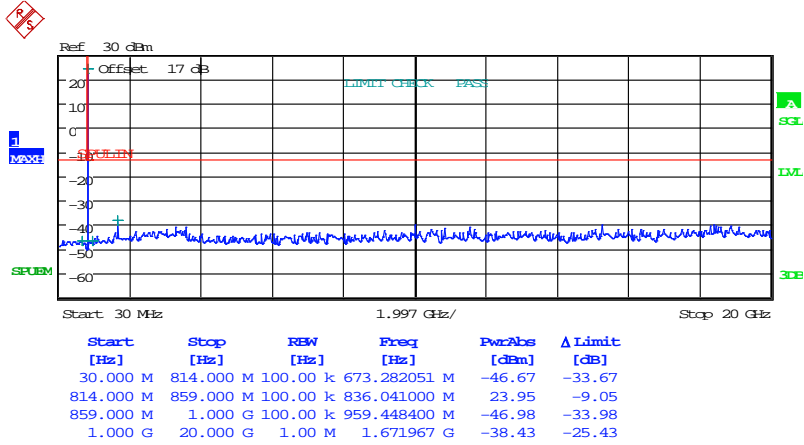

Date: 21.OCT.2024 15:05:02



Registration number: W6M22410-23833-C-247  
 FCC ID: GX9HYBLI

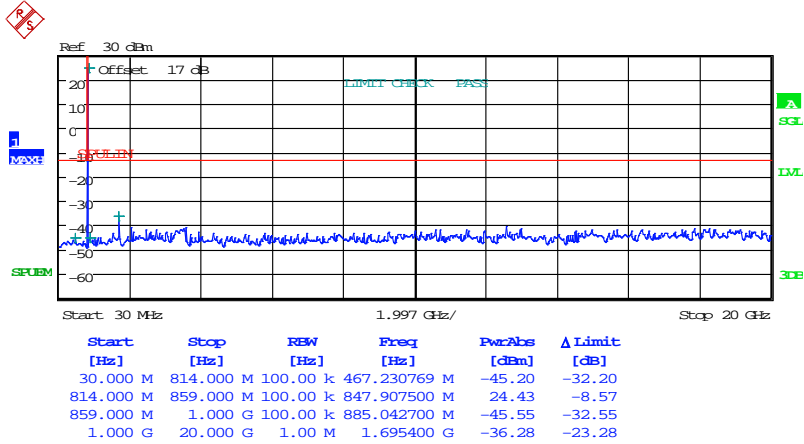

Date: 21.OCT.2024 15:04:20

3MHz  
 QPSK  
 1RB

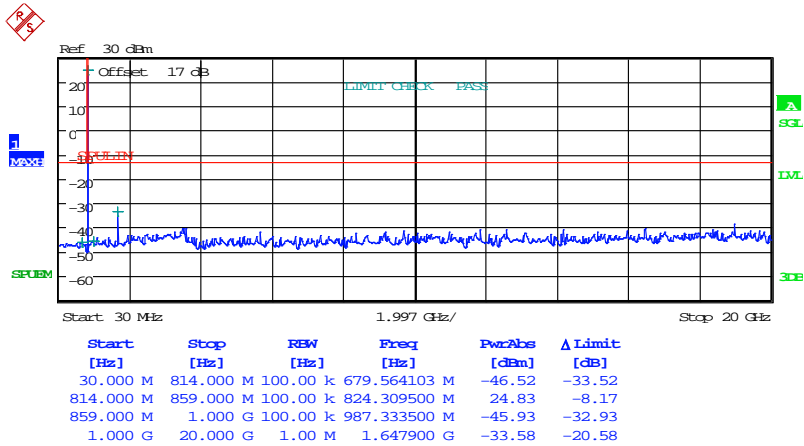

Date: 21.OCT.2024 15:08:04



# Worldwide Testing Services(Taiwan) Co., Ltd.

Registration number: W6M22410-23833-C-247  
 FCC ID: GX9HYBLI

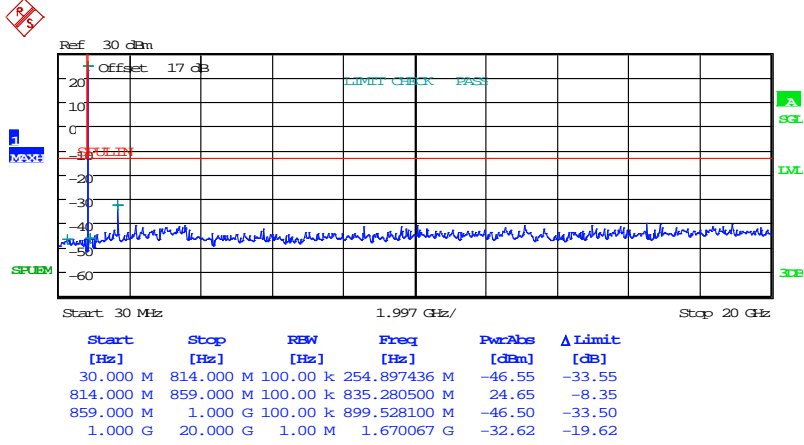

Date: 21.OCT.2024 15:08:21

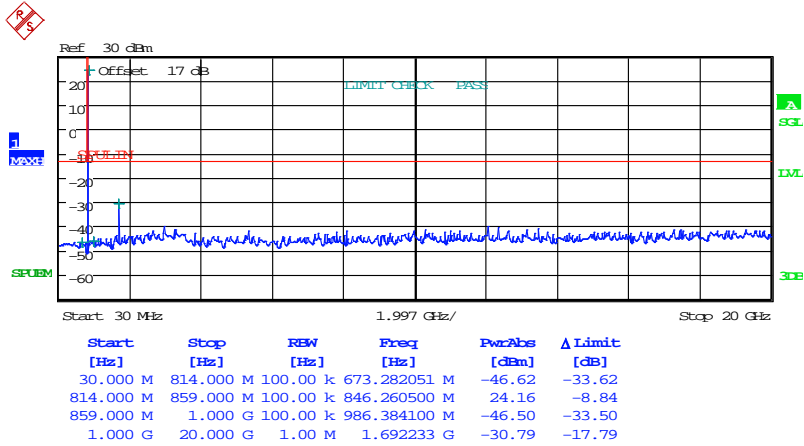

Date: 21.OCT.2024 15:07:47





# Worldwide Testing Services(Taiwan) Co., Ltd.

Registration number: W6M22410-23833-C-247  
 FCC ID: GX9HYBLI  
 16QAM  
 1RB

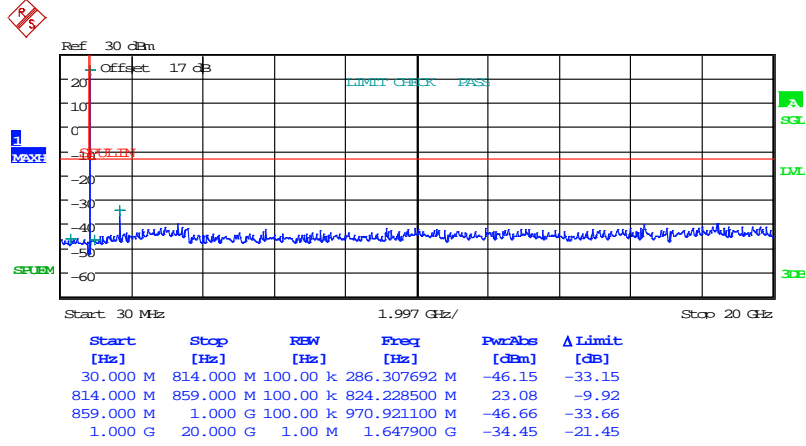

Date: 21.OCT.2024 15:07:05

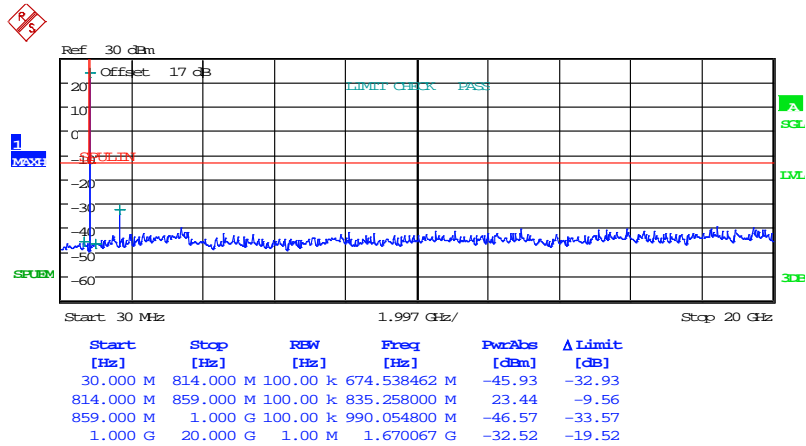

Date: 21.OCT.2024 15:05:37



# Worldwide Testing Services(Taiwan) Co., Ltd.

Registration number: W6M22410-23833-C-247  
 FCC ID: GX9HYBLI

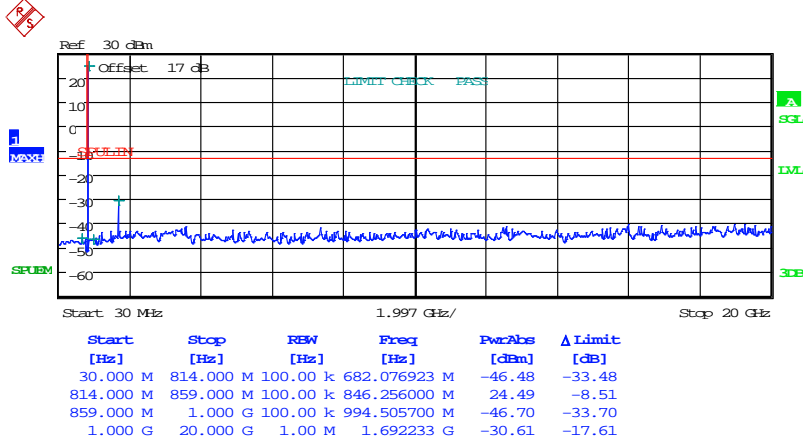

Date: 21.OCT.2024 15:07:19

5MHz  
 QPSK  
 1RB

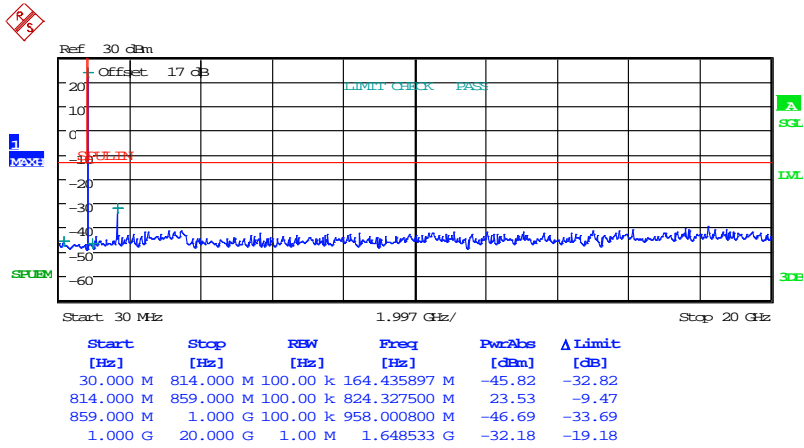

Date: 21.OCT.2024 15:09:12



# Worldwide Testing Services(Taiwan) Co., Ltd.

Registration number: W6M22410-23833-C-247  
 FCC ID: GX9HYBLI

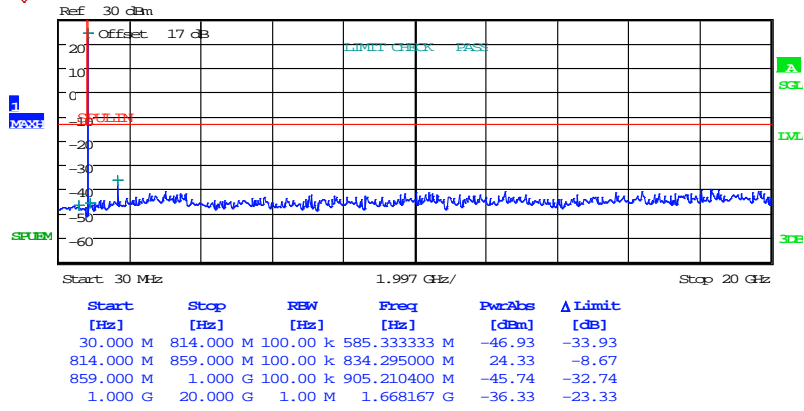

Date: 21.OCT.2024 15:08:53

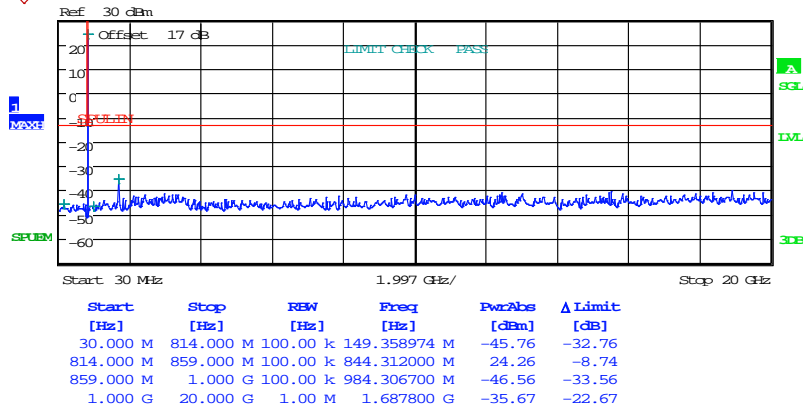

Date: 21.OCT.2024 15:09:32



# Worldwide Testing Services(Taiwan) Co., Ltd.

Registration number: W6M22410-23833-C-247  
 FCC ID: GX9HYBLI  
 16QAM  
 1RB

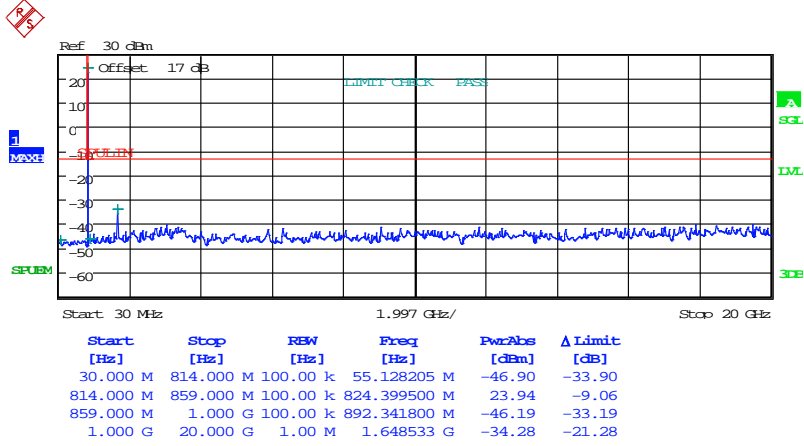

Date: 21.OCT.2024 15:12:07

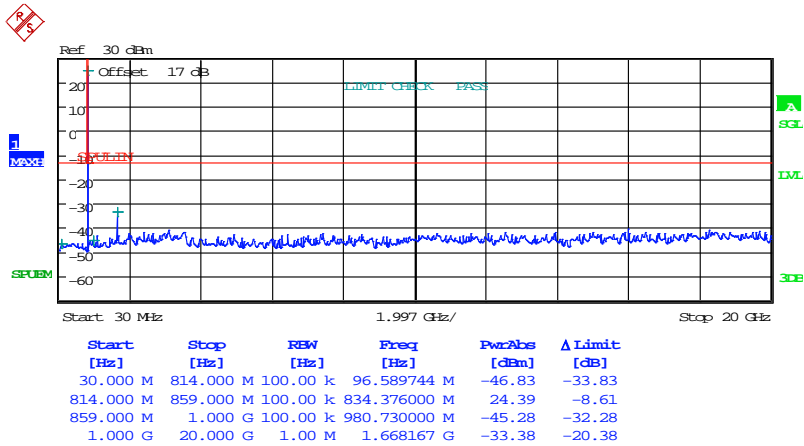

Date: 21.OCT.2024 15:12:24



Registration number: W6M22410-23833-C-247  
 FCC ID: GX9HYBLI

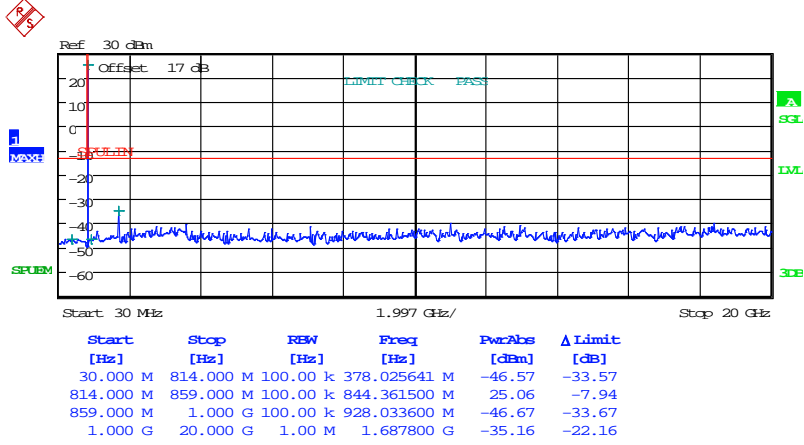

Date: 21.OCT.2024 15:09:55

10MHz  
 QPSK  
 1RB

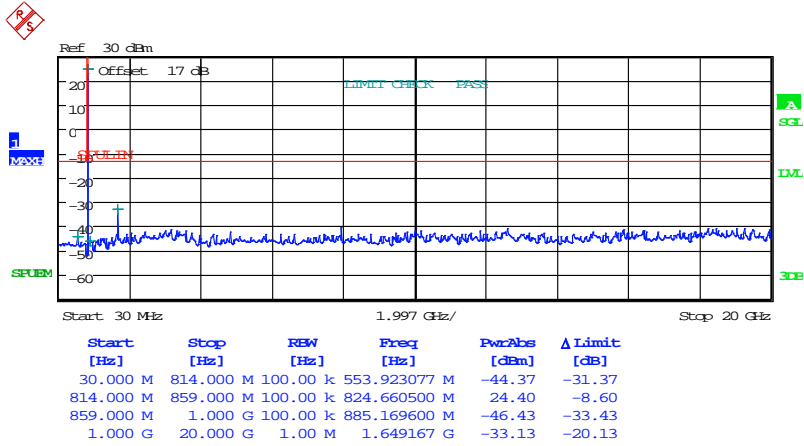

Date: 21.OCT.2024 15:15:09



# Worldwide Testing Services(Taiwan) Co., Ltd.

Registration number: W6M22410-23833-C-247  
 FCC ID: GX9HYBLI

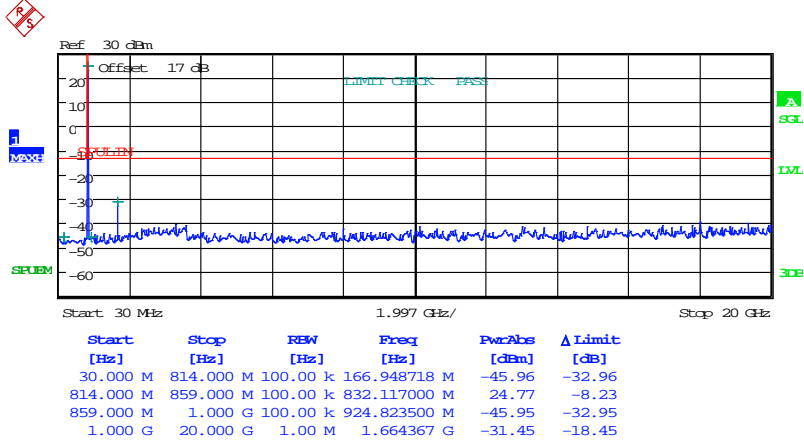

Date: 21.OCT.2024 15:15:27

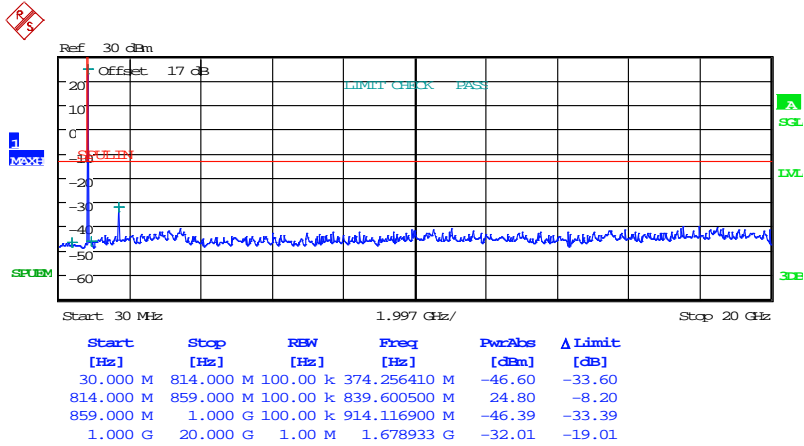

Date: 21.OCT.2024 15:14:37



# Worldwide Testing Services(Taiwan) Co., Ltd.

Registration number: W6M22410-23833-C-247  
 FCC ID: GX9HYBLI  
 16QAM  
 1RB

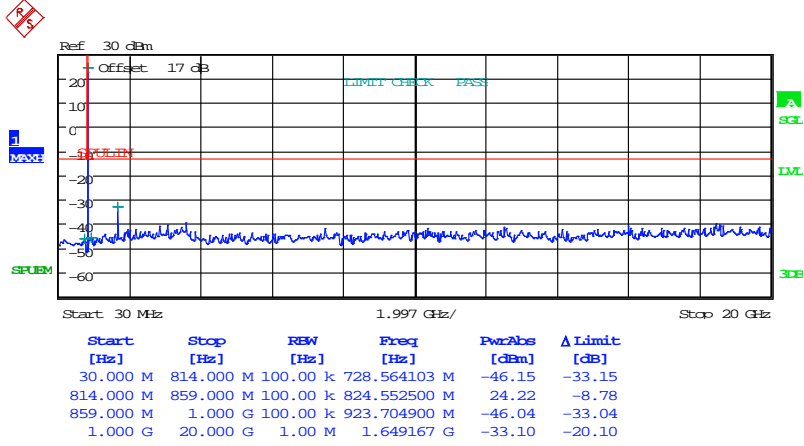

Date: 21.OCT.2024 15:13:26

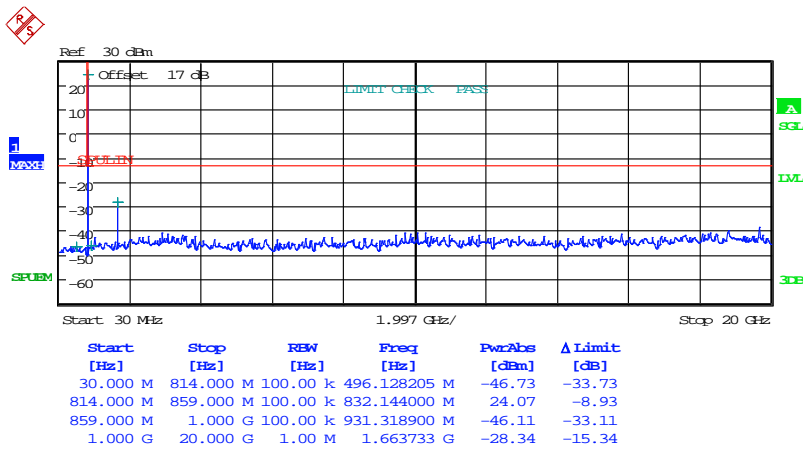

Date: 21.OCT.2024 15:13:10



Registration number: W6M22410-23833-C-247

FCC ID: GX9HYBLI

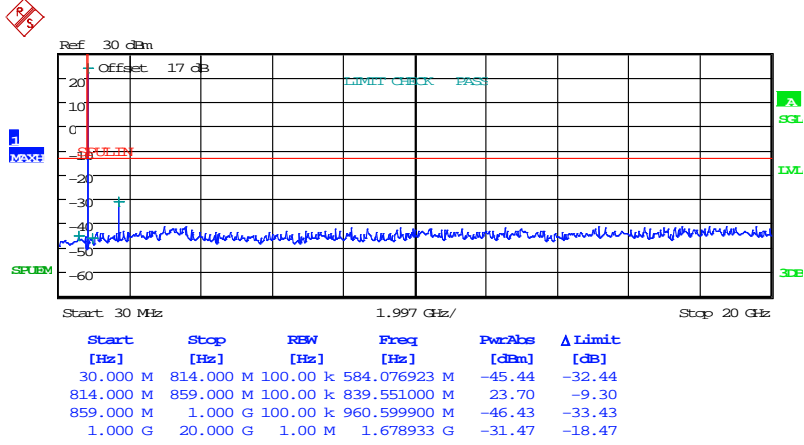

Date: 21.OCT.2024 15:14:13

Band 7  
5MHz  
QPSK  
1RB

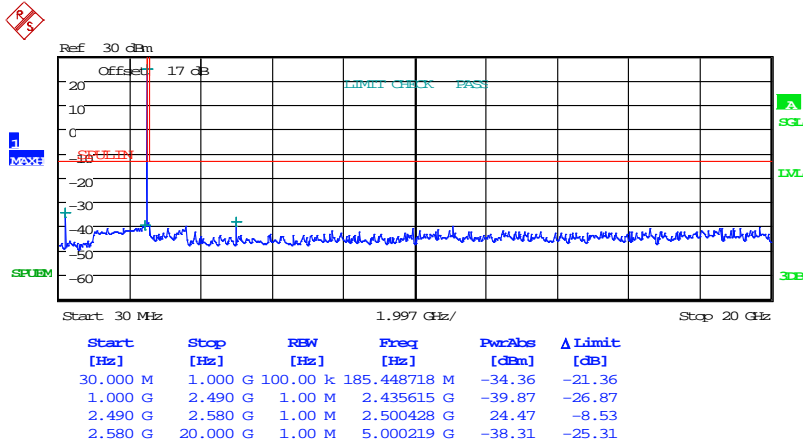

Date: 21.OCT.2024 15:58:28





# Worldwide Testing Services(Taiwan) Co., Ltd.

Registration number: W6M22410-23833-C-247

FCC ID: GX9HYBLI

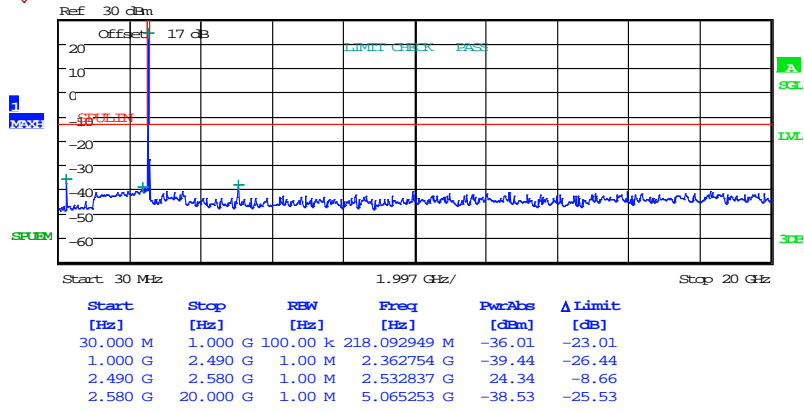

Date: 21.OCT.2024 16:00:33

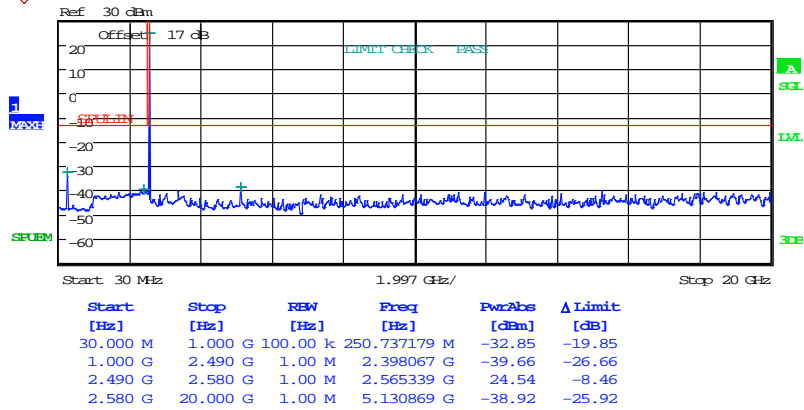

Date: 21.OCT.2024 15:58:09



# Worldwide Testing Services(Taiwan) Co., Ltd.

Registration number: W6M22410-23833-C-247  
 FCC ID: GX9HYBLI  
 16QAM  
 1RB

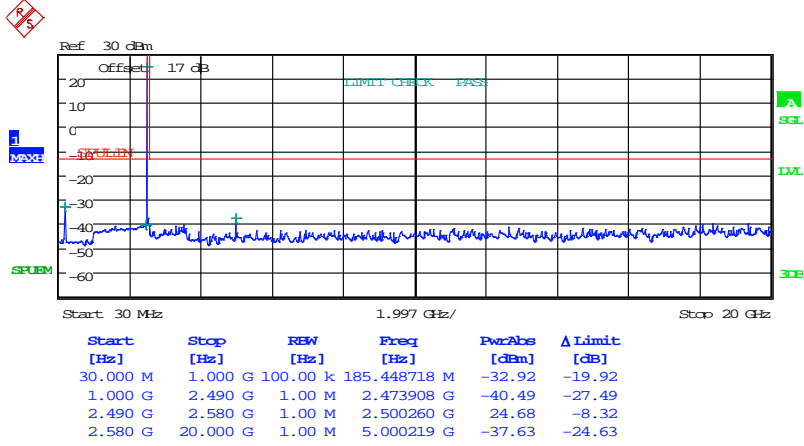

Date: 21.OCT.2024 15:57:07

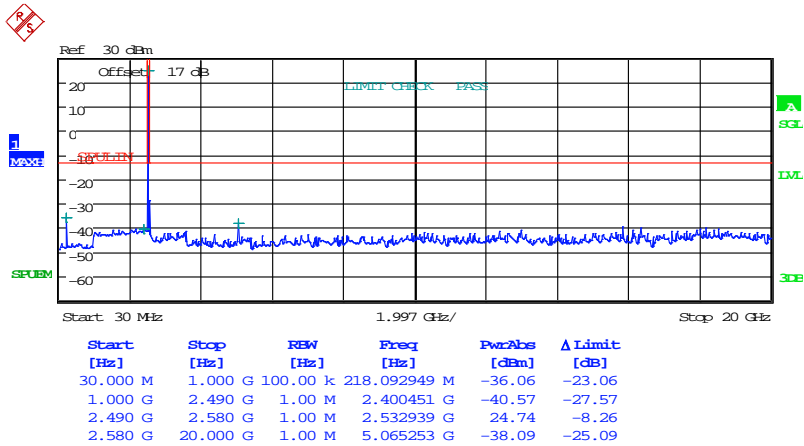

Date: 21.OCT.2024 15:56:45

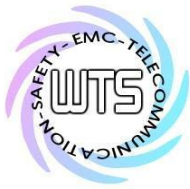

Registration number: W6M22410-23833-C-247  
 FCC ID: GX9HYBLI

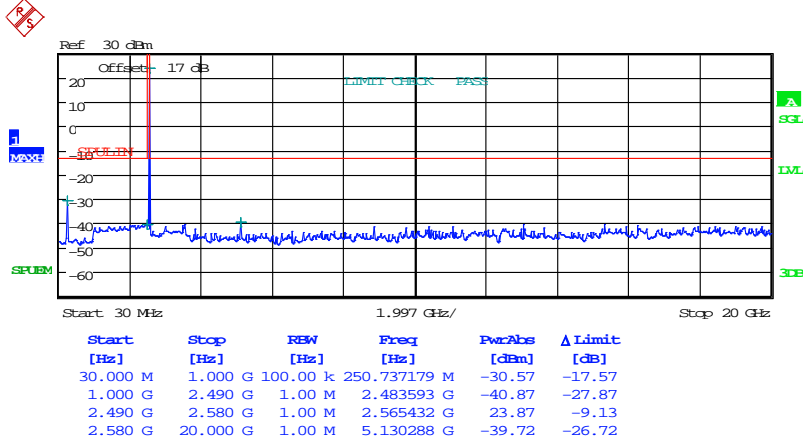

Date: 21.OCT.2024 15:57:48

10MHz  
 QPSK  
 1RB

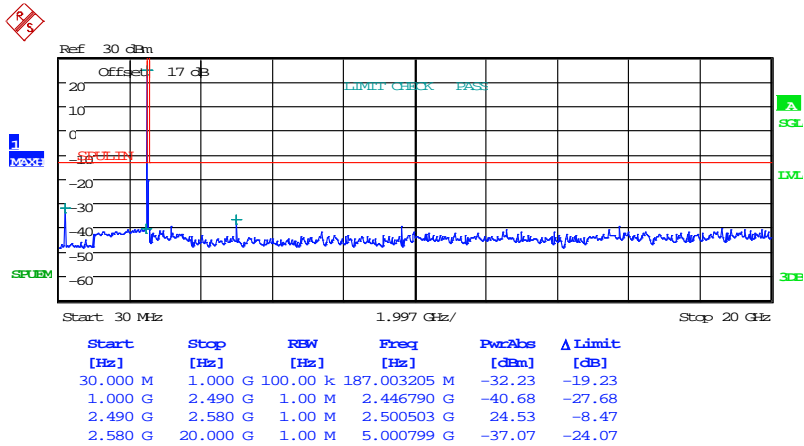

Date: 21.OCT.2024 16:01:23

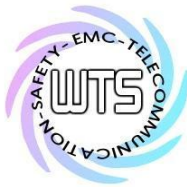

# Worldwide Testing Services(Taiwan) Co., Ltd.

Registration number: W6M22410-23833-C-247

FCC ID: GX9HYBLI

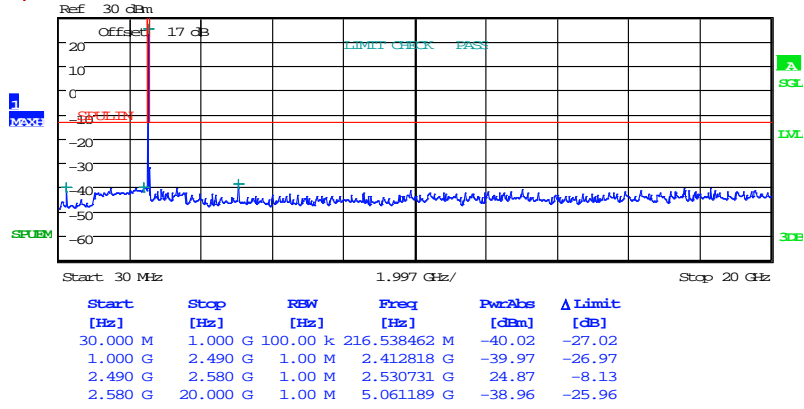

Date: 21.OCT.2024 16:01:10

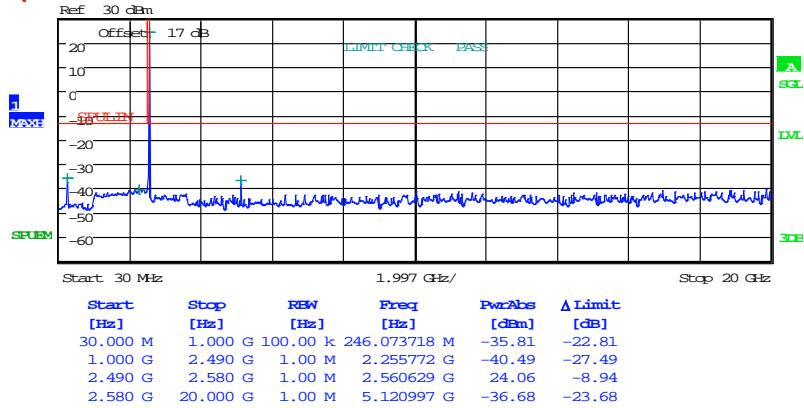

Date: 21.OCT.2024 16:01:50



# Worldwide Testing Services(Taiwan) Co., Ltd.

Registration number: W6M22410-23833-C-247  
 FCC ID: GX9HYBLI  
 16QAM  
 1RB

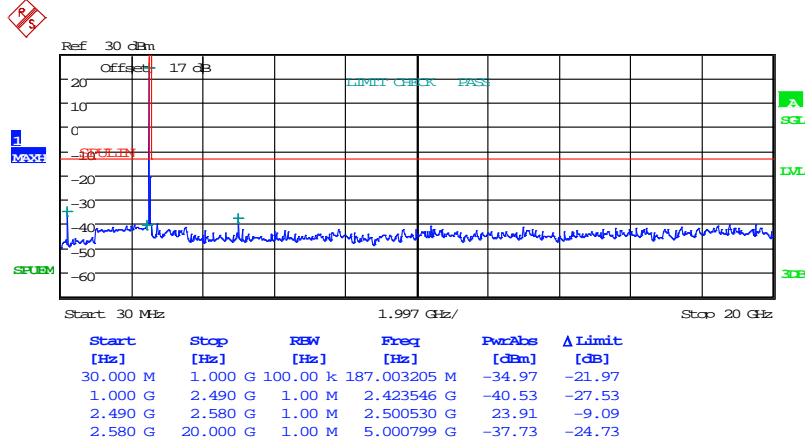

Date: 21.OCT.2024 16:02:55

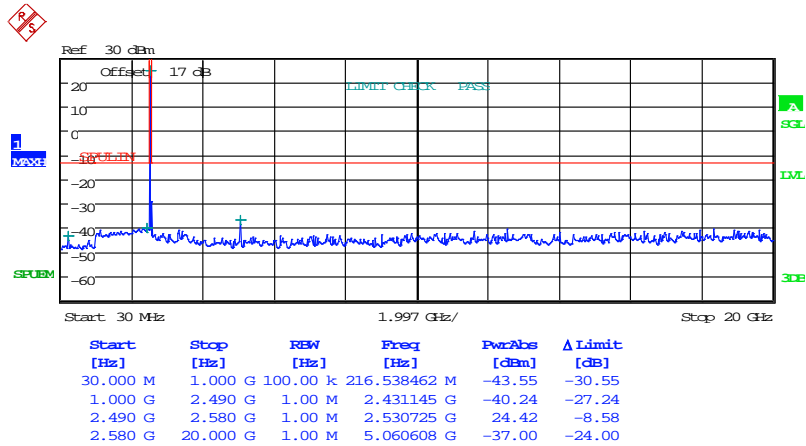

Date: 21.OCT.2024 16:03:22



Registration number: W6M22410-23833-C-247  
 FCC ID: GX9HYBLI

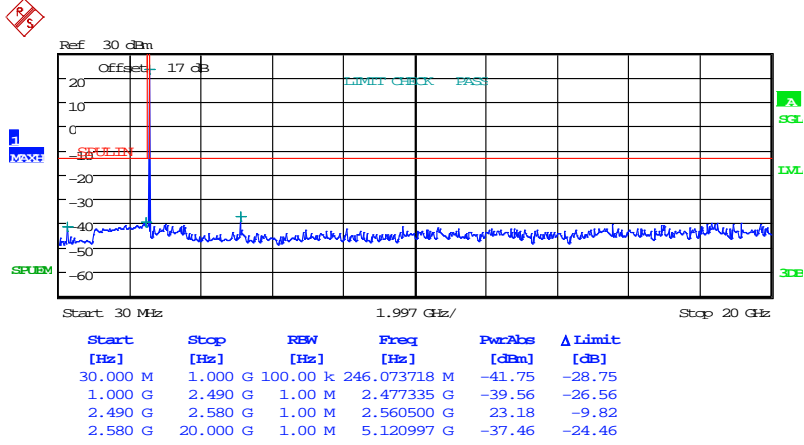

Date: 21.OCT.2024 16:02:23

15MHz  
 QPSK  
 1RB

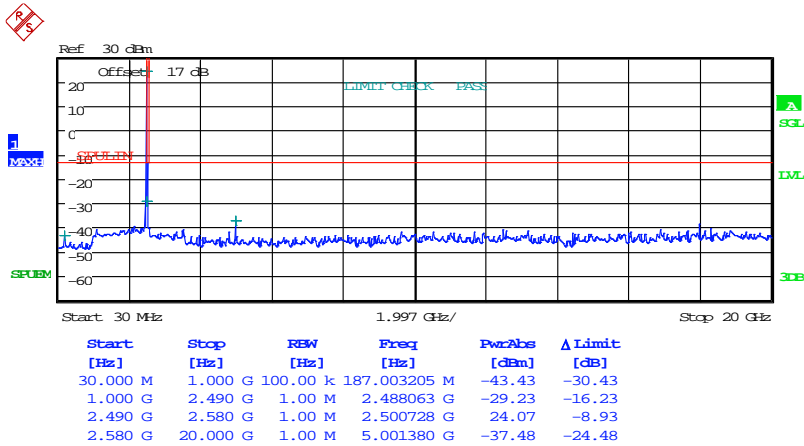

Date: 21.OCT.2024 16:07:57



# Worldwide Testing Services(Taiwan) Co., Ltd.

Registration number: W6M22410-23833-C-247  
 FCC ID: GX9HYBLI

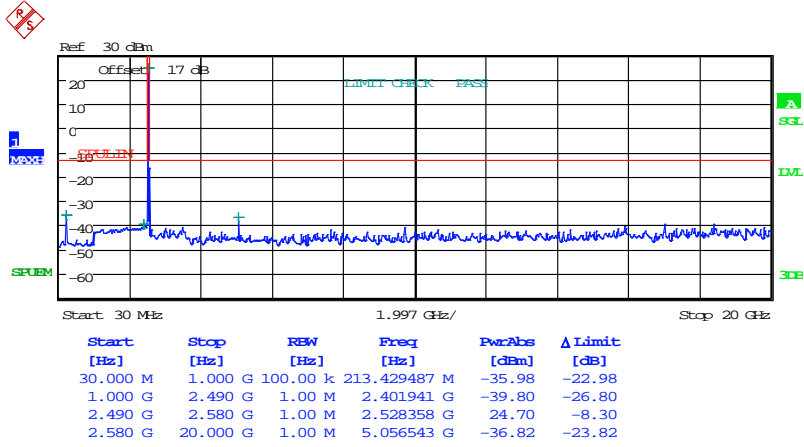

Date: 21.OCT.2024 16:08:31

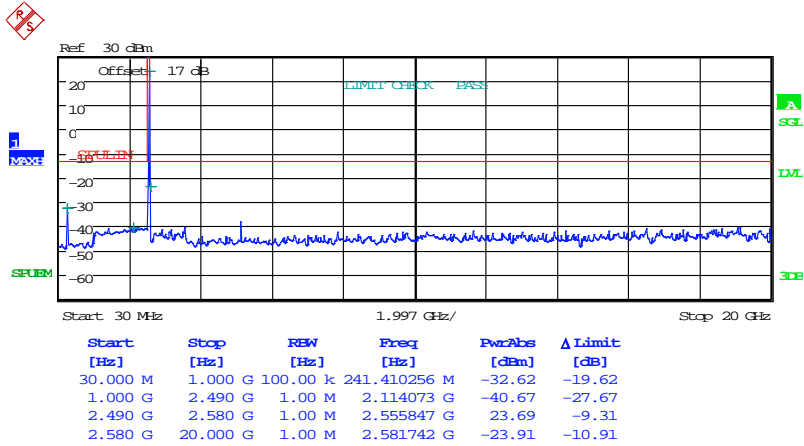

Date: 21.OCT.2024 16:07:06



# Worldwide Testing Services(Taiwan) Co., Ltd.

Registration number: W6M22410-23833-C-247  
 FCC ID: GX9HYBLI  
 16QAM  
 1RB

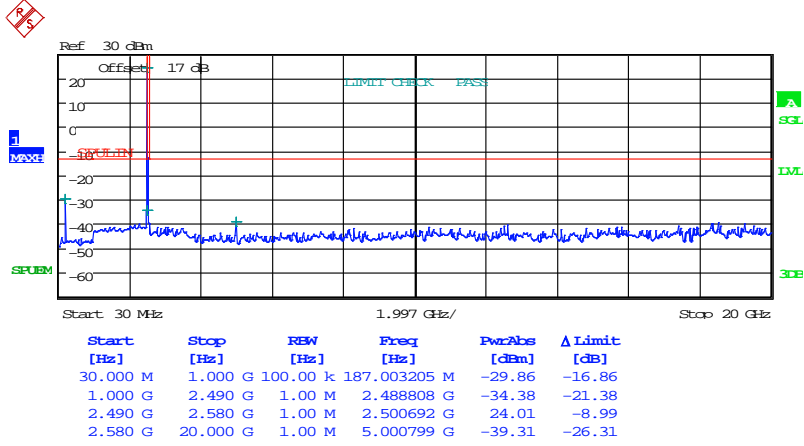

Date: 21.OCT.2024 16:05:35

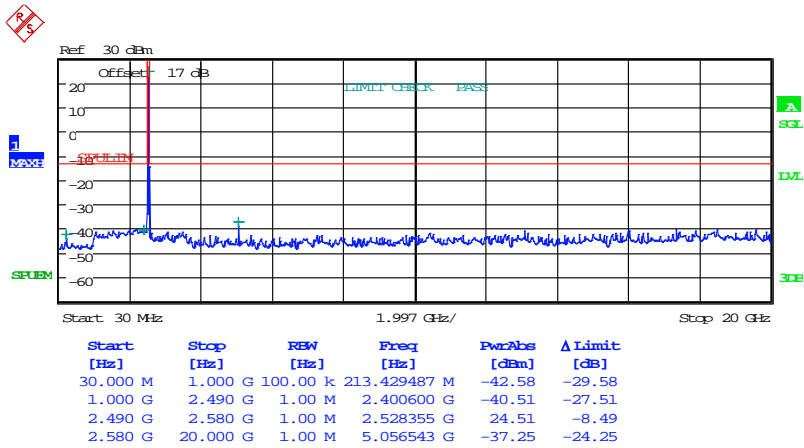

Date: 21.OCT.2024 16:05:06





# Worldwide Testing Services(Taiwan) Co., Ltd.

Registration number: W6M22410-23833-C-247

FCC ID: GX9HYBLI

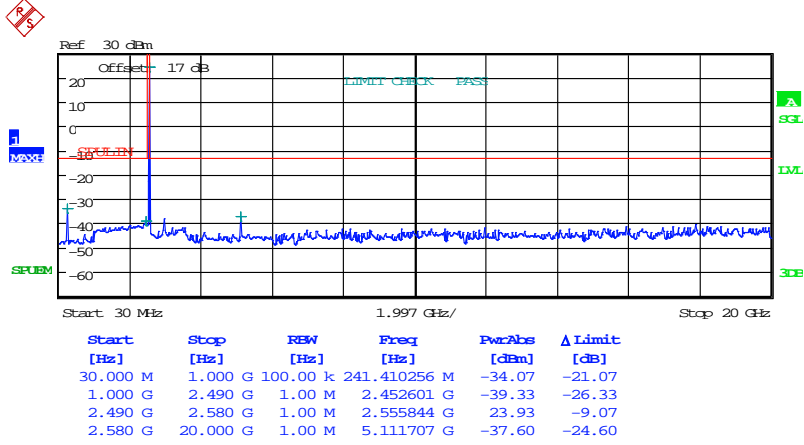

Date: 21.OCT.2024 16:06:11

20MHz  
QPSK  
1RB

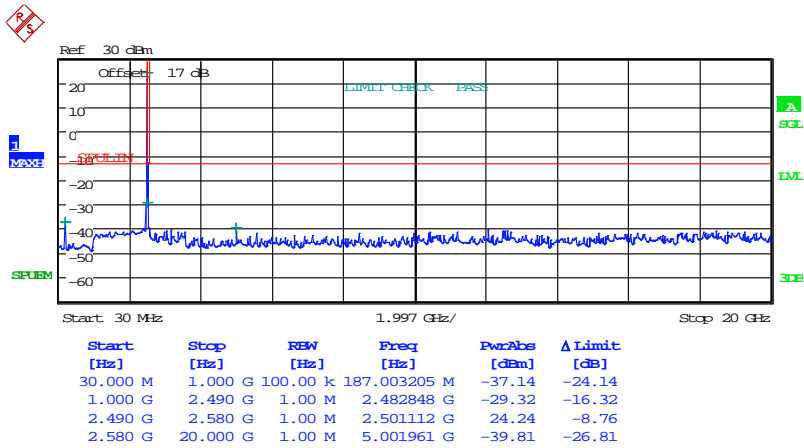

Date: 21.OCT.2024 16:10:08



Registration number: W6M22410-23833-C-247  
 FCC ID: GX9HYBLI

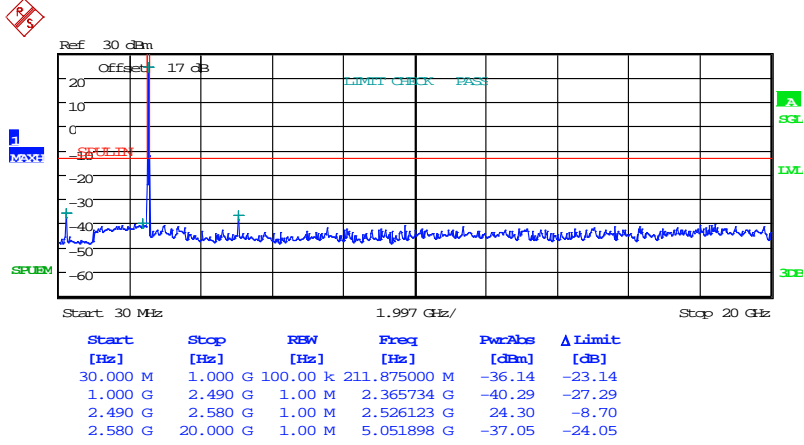

Date: 21.OCT.2024 16:09:03

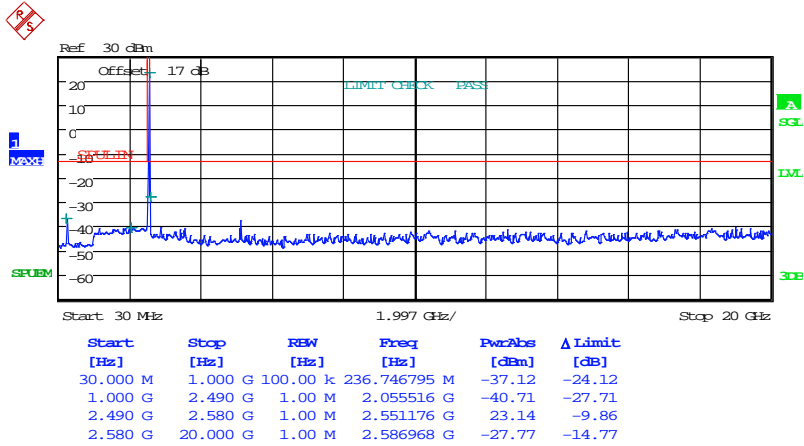

Date: 21.OCT.2024 16:12:40



# Worldwide Testing Services(Taiwan) Co., Ltd.

Registration number: W6M22410-23833-C-247  
 FCC ID: GX9HYBLI  
 16QAM  
 1RB

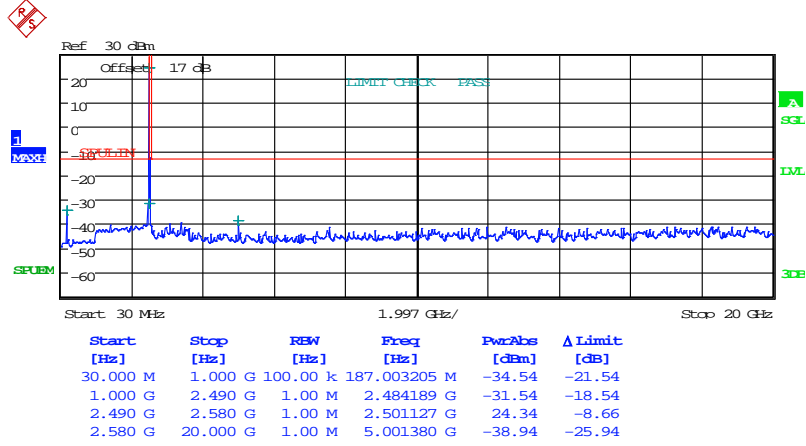

Date: 21.OCT.2024 16:15:05

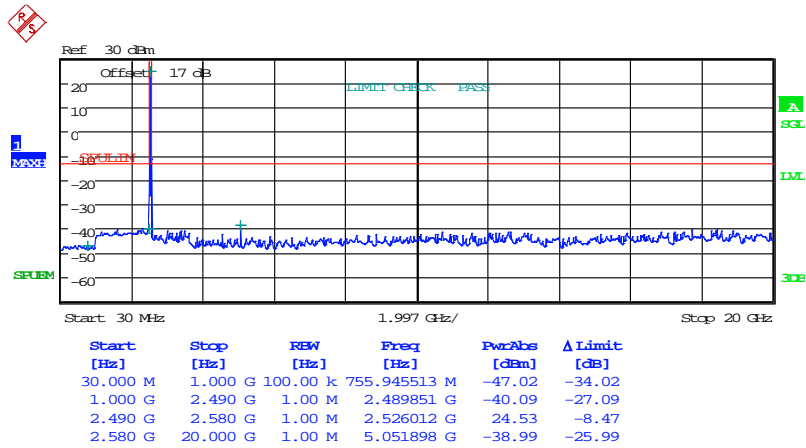

Date: 21.OCT.2024 16:15:29



Registration number: W6M22410-23833-C-247  
 FCC ID: GX9HYBLI

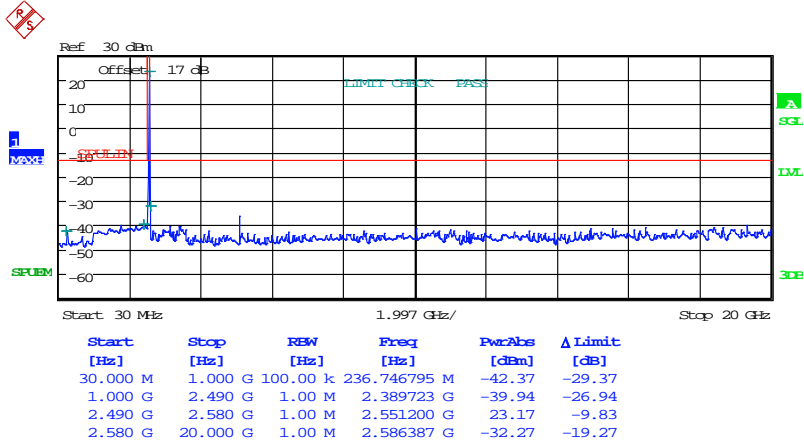

Date: 21.OCT.2024 16:13:12

Band 40  
 5MHz  
 QPSK  
 1RB

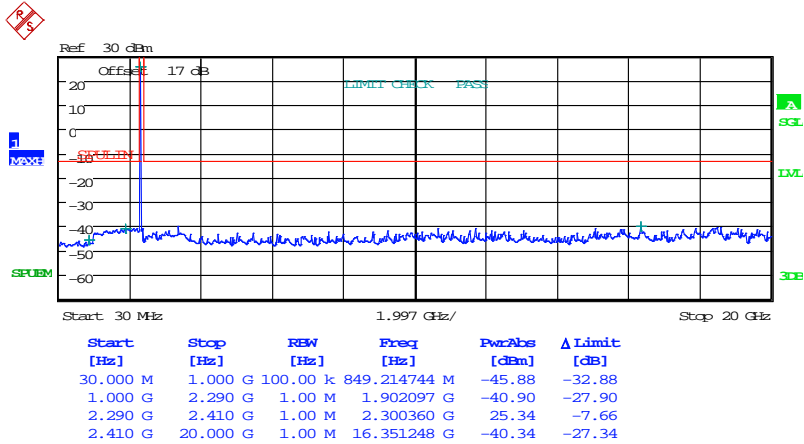

Date: 21.OCT.2024 16:22:24



# Worldwide Testing Services(Taiwan) Co., Ltd.

Registration number: W6M22410-23833-C-247  
 FCC ID: GX9HYBLI

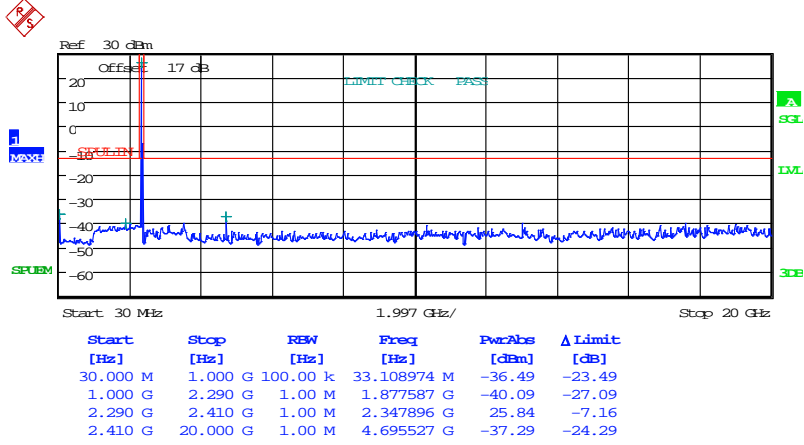

Date: 21.OCT.2024 16:22:43

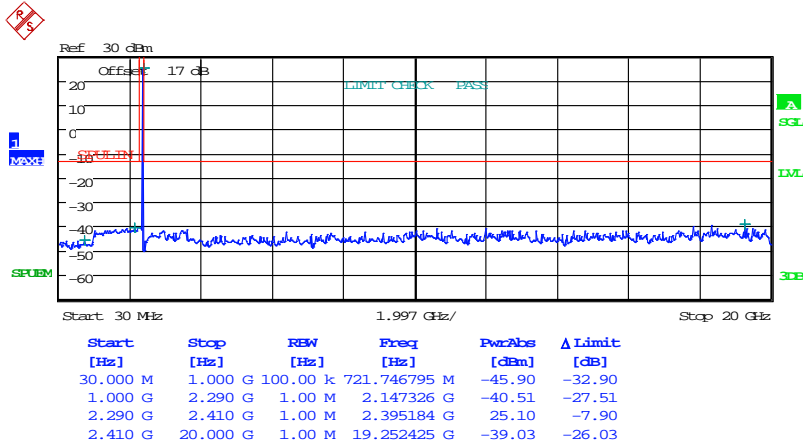

Date: 21.OCT.2024 16:22:05



# Worldwide Testing Services(Taiwan) Co., Ltd.

Registration number: W6M22410-23833-C-247  
 FCC ID: GX9HYBLI  
 16QAM  
 1RB

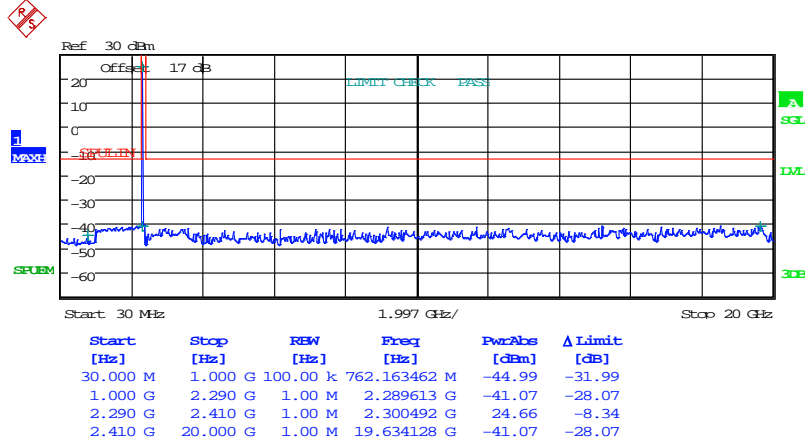

Date: 21.OCT.2024 16:21:07

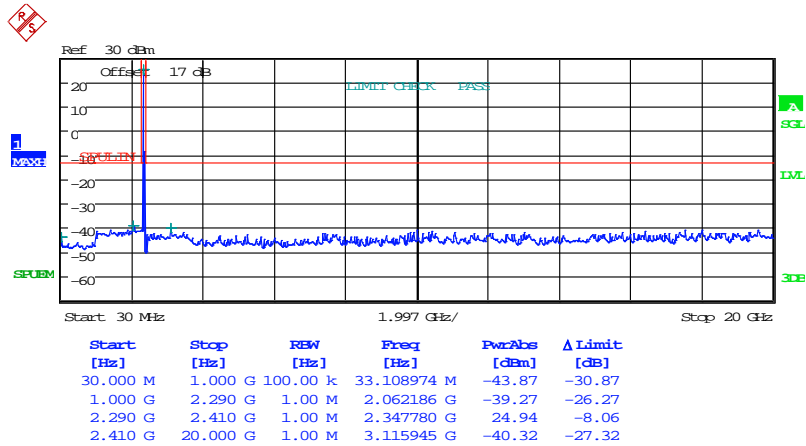

Date: 21.OCT.2024 16:20:51



# Worldwide Testing Services(Taiwan) Co., Ltd.

Registration number: W6M22410-23833-C-247

FCC ID: GX9HYBLI

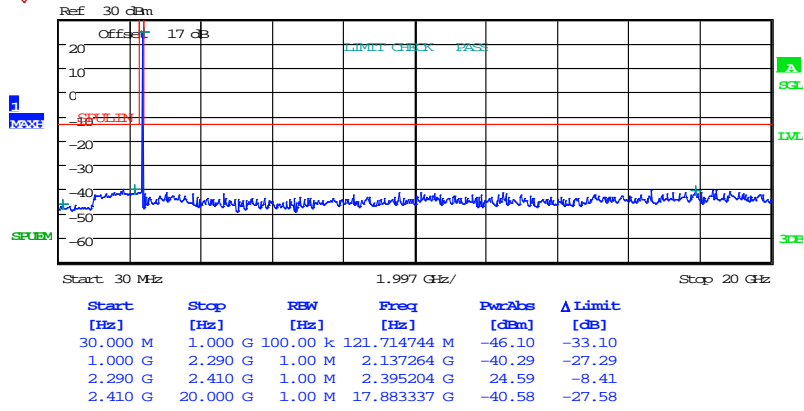

Date: 21.OCT.2024 16:21:22

10MHz  
QPSK  
1RB

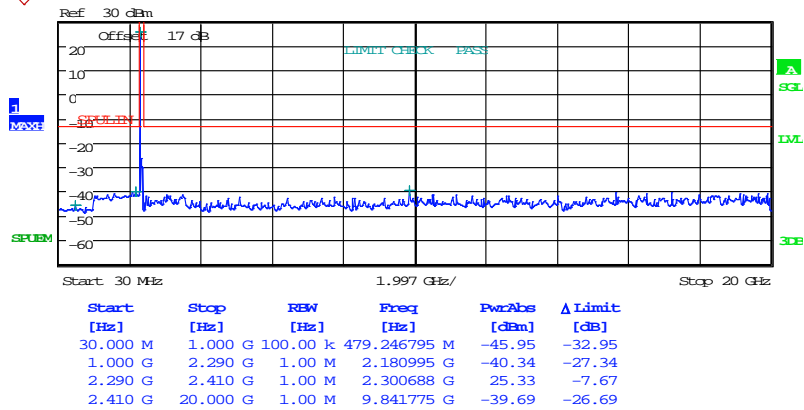

Date: 21.OCT.2024 16:24:53



# Worldwide Testing Services(Taiwan) Co., Ltd.

Registration number: W6M22410-23833-C-247  
 FCC ID: GX9HYBLI

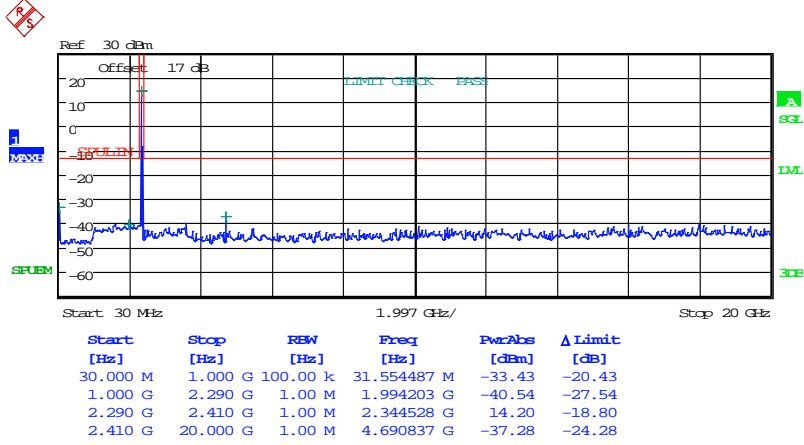

Date: 21.OCT.2024 16:24:26

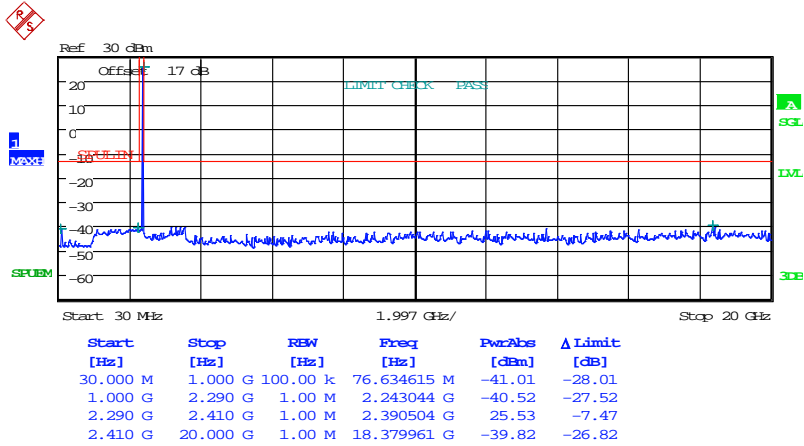

Date: 21.OCT.2024 16:25:20





# Worldwide Testing Services(Taiwan) Co., Ltd.

Registration number: W6M22410-23833-C-247  
 FCC ID: GX9HYBLI  
 16QAM  
 1RB

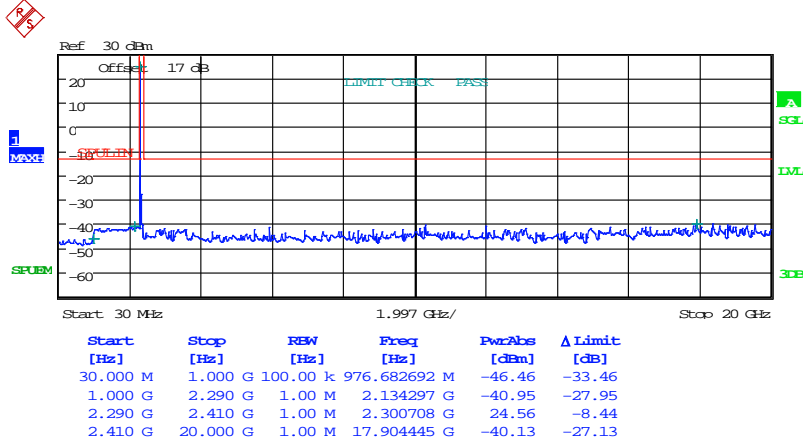

Date: 21.OCT.2024 16:26:40

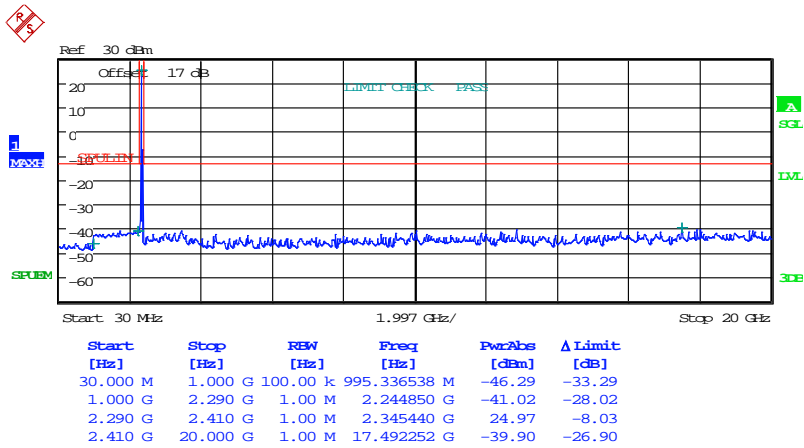

Date: 21.OCT.2024 16:26:58

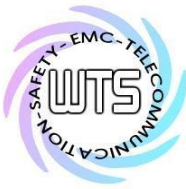

# Worldwide Testing Services(Taiwan) Co., Ltd.

Registration number: W6M22410-23833-C-247  
 FCC ID: GX9HYBLI

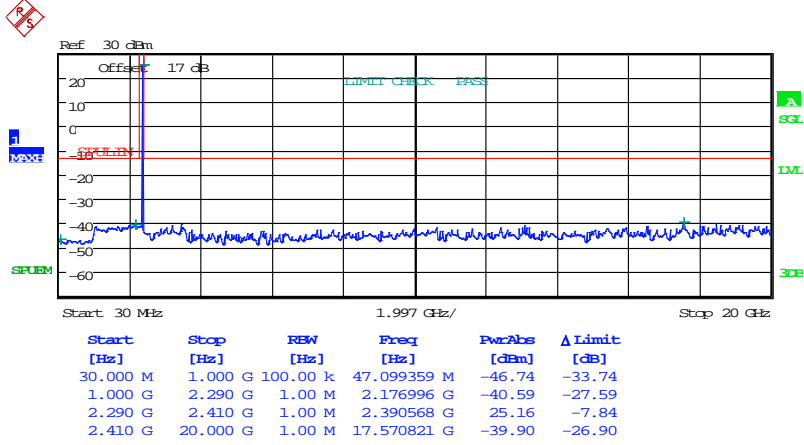

Date: 21.OCT.2024 16:26:11

15MHz  
 QPSK  
 1RB

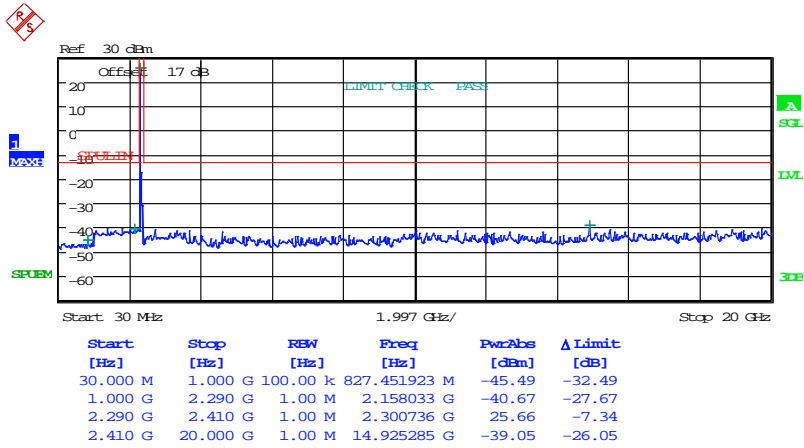

Date: 21.OCT.2024 16:30:41



# Worldwide Testing Services(Taiwan) Co., Ltd.

Registration number: W6M22410-23833-C-247

FCC ID: GX9HYBLI

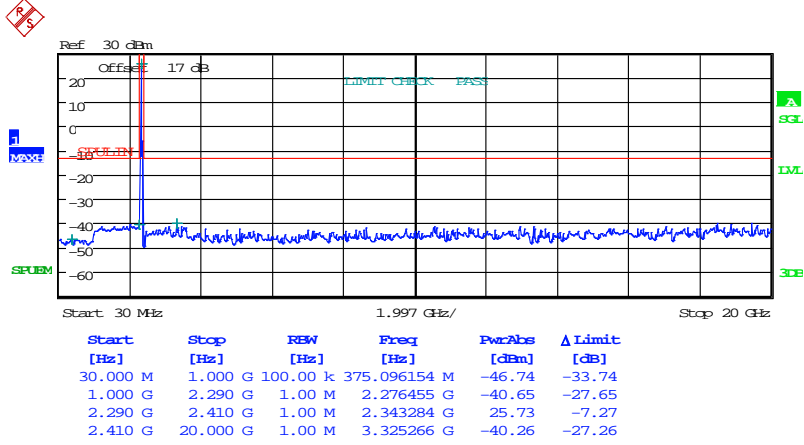

Date: 21.OCT.2024 16:31:08

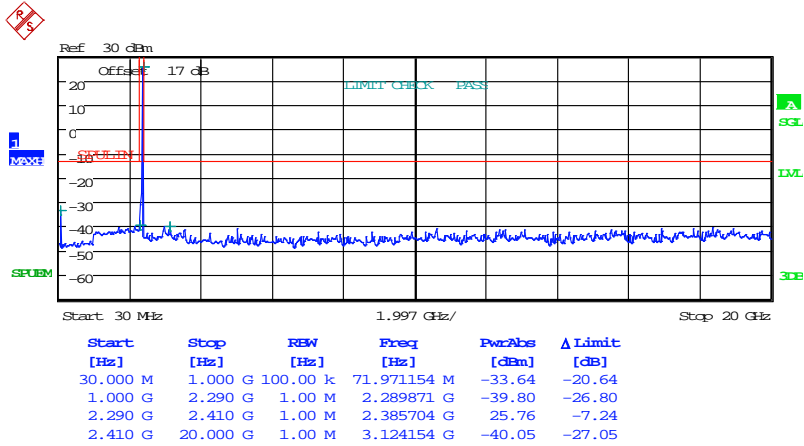

Date: 21.OCT.2024 16:30:26



# Worldwide Testing Services(Taiwan) Co., Ltd.

Registration number: W6M22410-23833-C-247  
 FCC ID: GX9HYBLI  
 16QAM  
 1RB

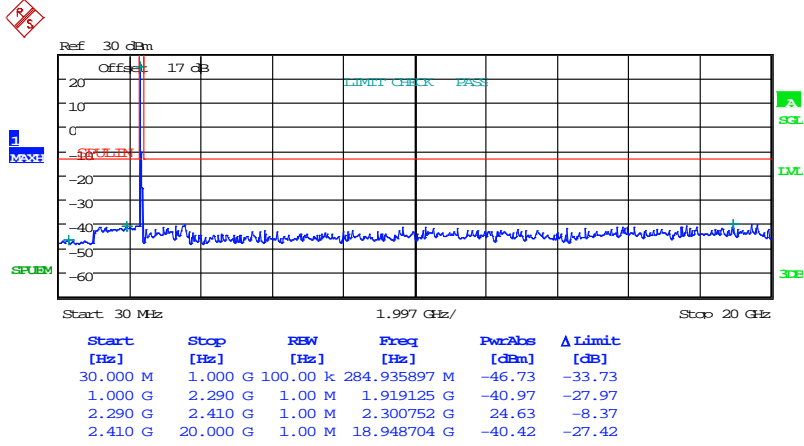

Date: 21.OCT.2024 16:29:44

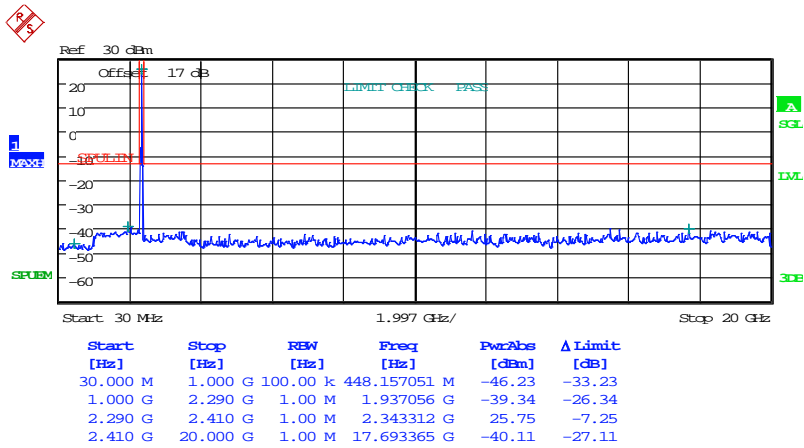

Date: 21.OCT.2024 16:29:29

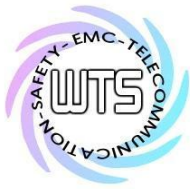

Registration number: W6M22410-23833-C-247  
 FCC ID: GX9HYBLI

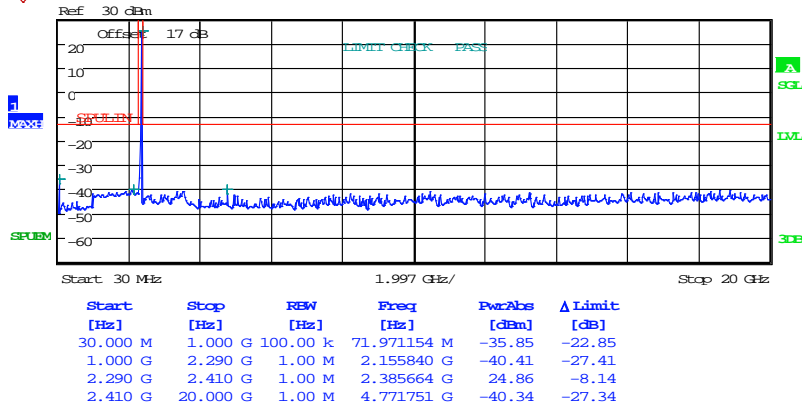

Date: 21.OCT.2024 16:30:02

20MHz  
 QPSK  
 1RB

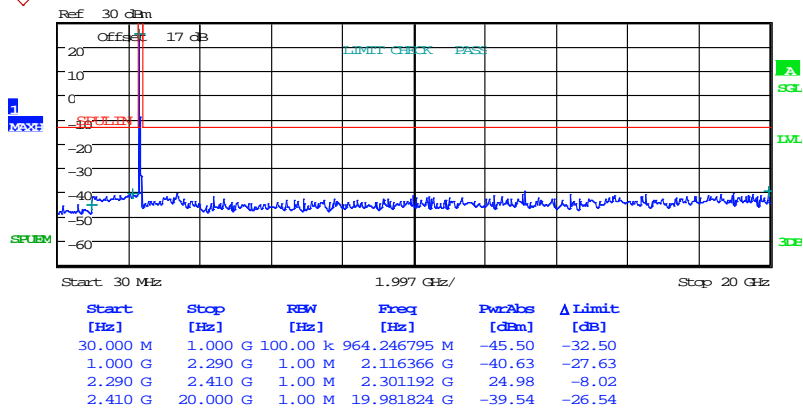

Date: 21.OCT.2024 16:32:16



# Worldwide Testing Services(Taiwan) Co., Ltd.

Registration number: W6M22410-23833-C-247  
 FCC ID: GX9HYBLI

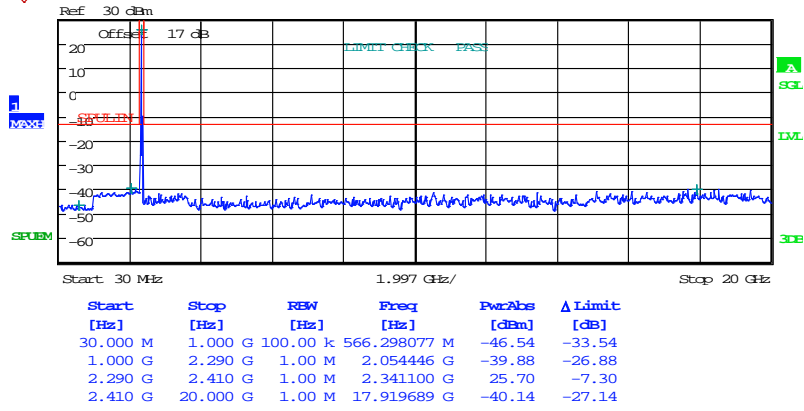

Date: 21.OCT.2024 16:31:38

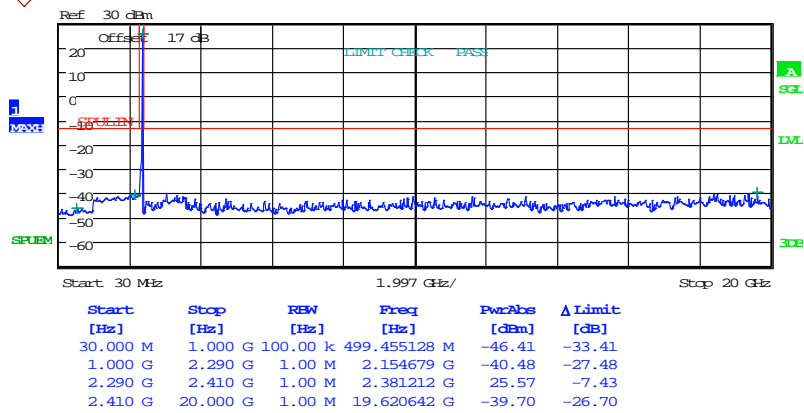

Date: 21.OCT.2024 16:32:43

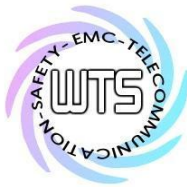

# Worldwide Testing Services(Taiwan) Co., Ltd.

Registration number: W6M22410-23833-C-247

FCC ID: GX9HYBLI

16QAM

1RB

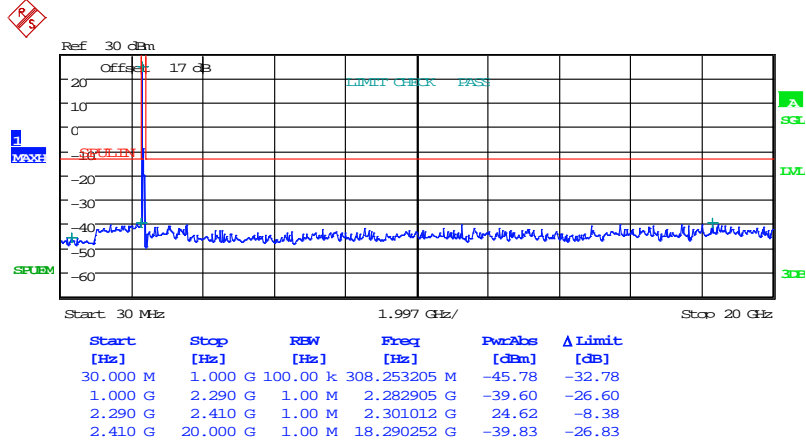

Date: 21.OCT.2024 16:33:35

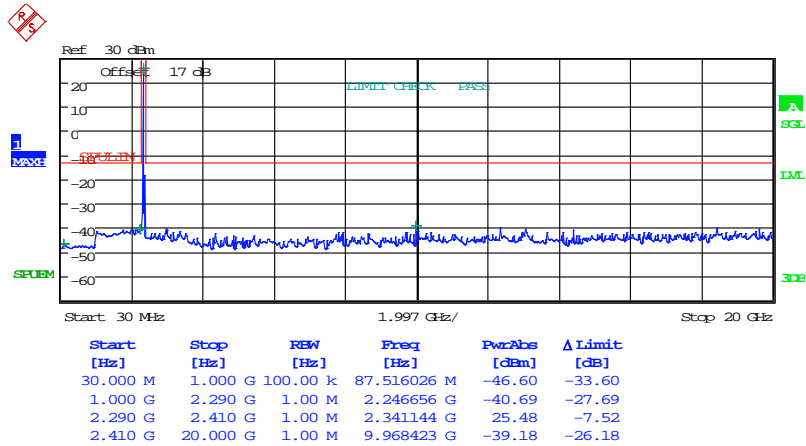

Date: 21.OCT.2024 16:33:49



Registration number: W6M22410-23833-C-247  
 FCC ID: GX9HYBLI

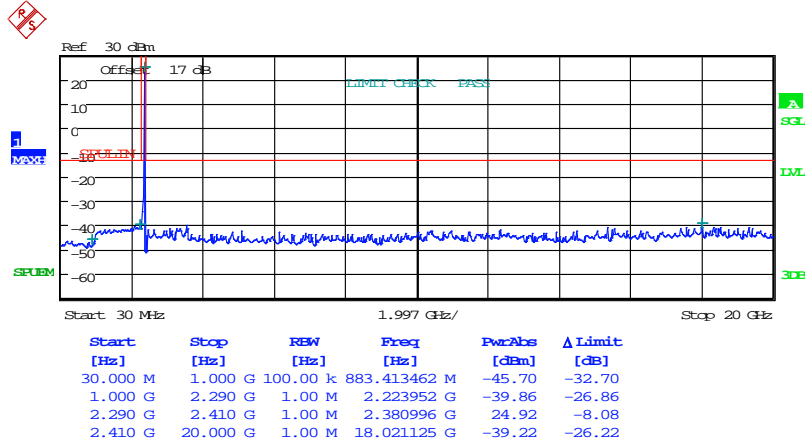

Date: 21.OCT.2024 16:33:14

### 7.3 Explanation of test result

All factors like cable loss and external attenuation etc. are already included in the provided measurement results. This is done by using validated test software and calibrated test system according the accreditation requirements.

### 7.4 Calculation of Limit for Spurious at Antenna Terminals

Compliance with § 22.917, §24.238, §27.53 requires that any emission be attenuated below the transmitter power at least  $43 + 10 \log P$  ( $P$  = transmitter power in Watts).

Limit for Spurious Emissions at Antenna Terminals:  $L=P-A=-13dBm$





Registration number: W6M22410-23833-C-247

FCC ID: GX9HYBLI

**8 Field Strength of Spurious Radiation**

**8.1 Test procedure**

The test procedure for filed strength measurement is same as radiated power except for a notch filter or band pass filter is used to avoid the influence of fundamental to the pre-amplifier. The measurements below 1GHz were performed with a measurement bandwidth of 100kHz, above 1GHz with a bandwidth of 1 MHz.

**8.2 Test Results**

The measurements of the spurious emission are at the upper, center and lower channel.

Model: HYBx-xxxxx-xxxxx Date: Series(x=0~9, A~Z or blank)  
 Mode: -- Temperature: -- °C Engineer: --  
 Polarization: Horizontal Humidity: -- %

Frequency (MHz)	Reading (dBm) Peak	Factor (dB) Corr.	Result (dBm)	Limit (dBm)	Margin (dB)	Table Degree (Deg.)	Ant. High (cm)
--	--	--	--	--	--	--	--
--	--	--	--	--	--	--	--

Polarization: Vertical

Frequency (MHz)	Reading (dBm) Peak	Factor (dB) Corr.	Result (dBm)	Limit (dBm)	Margin (dB)	Table Degree (Deg.)	Ant. High (cm)
--	--	--	--	--	--	--	--
--	--	--	--	--	--	--	--

- Note**
1. Correction Factor = Antenna factor + Cable loss - Preamplifier
  2. The formula of measured value as: Test Result = Reading + Correction Factor
  3. Detector function in the form: PK = Peak, QP = Quasi Peak, AV = Average
  4. All not in the table noted test results are more than 20 dB below the relevant limits.
  5. See attached diagrams in appendix.

**8.3 Explanation of test result**

Result Level = Reading Level + Corrected Factor  
 Corrected Factor = SG level – Received level-Cable loss + substitution antenna gain

**8.4 Calculation of Limit for Field Strength of Spurious**

Compliance with § 22.917, § 24.238, § 27.53 requires that any emission be attenuated below the transmitter power at least 43 + 10 log P (P = transmitter power in Watts).

Limit for Spurious Emissions at Antenna Terminals: L=P-A=-13dBm



Registration number: W6M22410-23833-C-247

FCC ID: GX9HYBLI

## 8.5 Test result of band edge emissions

Test date: October 21, 2024

Temperature: 24.5 °C

Humidity: 58.7 %

Tester: Sora

Band 2

1.4 MHz

QPSK

1RB

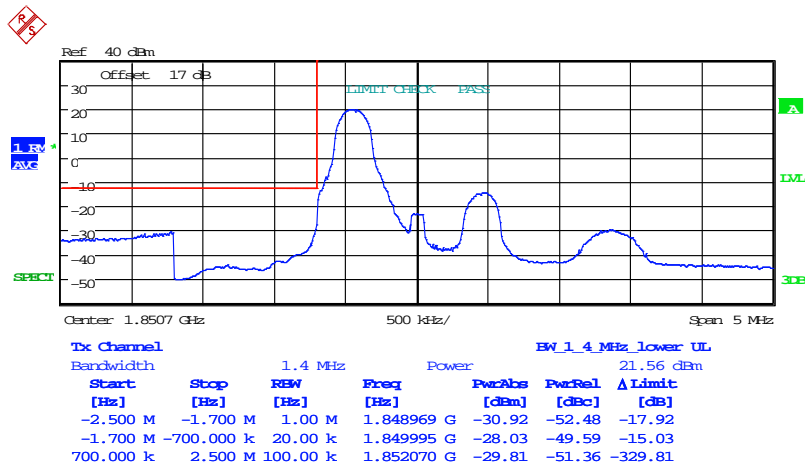

Date: 21.OCT.2024 10:49:16



Registration number: W6M22410-23833-C-247

FCC ID: GX9HYBLI

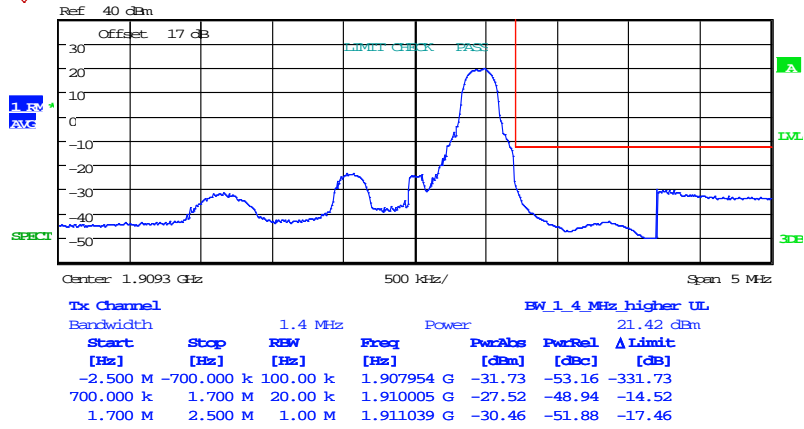

Date: 21.OCT.2024 10:46:40

FRB

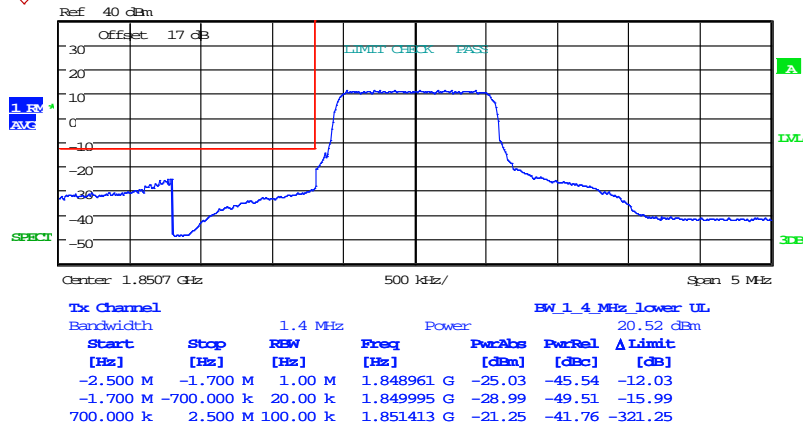

Date: 21.OCT.2024 10:48:46



Registration number: W6M22410-23833-C-247

FCC ID: GX9HYBLI

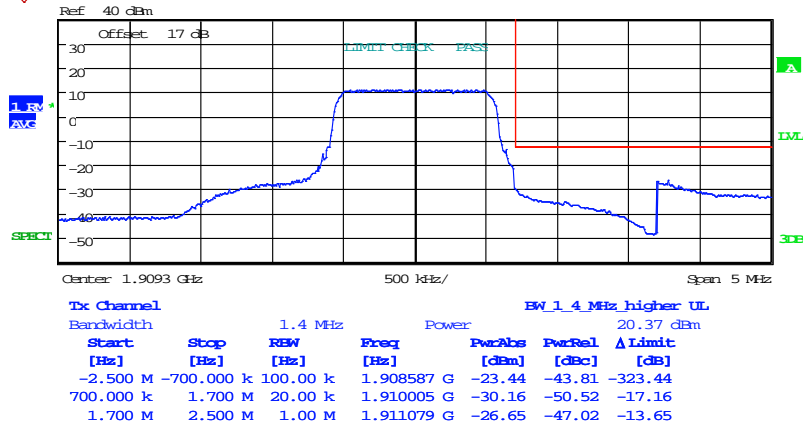

Date: 21.OCT.2024 10:47:04

16QAM  
1RB

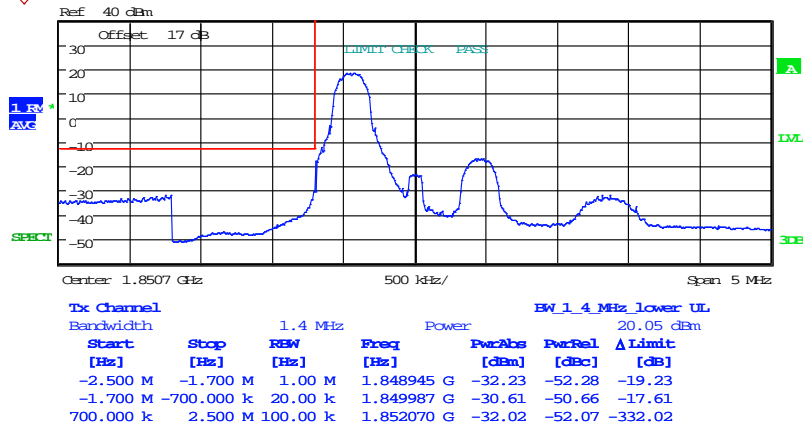

Date: 21.OCT.2024 10:48:16