

**ELECTROMAGNETIC EMISSIONS COMPLIANCE REPORT  
INTENTIONAL RADIATOR CERTIFICATION TO  
FCC PART 15 SUBPART C REQUIREMENT**

**OF**

**Pro Fit™ 2.4GHz Wireless Mid-size Mouse.**

**MODEL No.: M01092-D**

**BRAND NAME:**  **Kensington®**

**FCC ID: GV3M01092-D**

**REPORT NO: ED10040016-1**

**ISSUE DATE: April 08, 2010**

*Prepared for*  
**ACCO Brands, Inc.**  
**333 Twin Dolphin Drive, 6th Floor, Redwood Shores, CA, 94065, U.S.A**

*Prepared by*  
**DONGGUAN EMTEK CO., LTD**

**No.281, Guantai Road, Nancheng District,  
Dongguan, Guangdong, China  
TEL: 86-769-22807078  
FAX: 86-769-22807079**

**VERIFICATION OF COMPLIANCE**

Applicant:	ACCO Brands, Inc. 333 Twin Dolphin Drive, 6th Floor, Redwood Shores, CA, 94065, U.S.A
Product Description:	Pro Fit™ 2.4GHz Wireless Mid-size Mouse.
Brand Name:	 Kensington®
Model Number:	M01092-D
File Number:	ED10040016-1
Date of Test:	January 14, 2010 to March 30, 2010

**We hereby certify that:**

The above equipment was tested by DONGGUAN EMTEK CO., LTD. The test data, data evaluation, test procedures, and equipment configurations shown in this report were made in accordance with the procedures given in ANSI C63.4 (2003) and the energy emitted by the sample EUT tested as described in this report is in compliance with conducted and radiated emission limits of FCC Rules Part 15.249.

The test results of this report relate only to the tested sample identified in this report.

*Approved By*



---

*Nicol Lee / Q.A. Manager*  
**DONGGUAN EMTEK CO., LTD.**

## Table of Contents

<b>1. GENERAL INFORMATION .....</b>	<b>4</b>
1.1 PRODUCT DESCRIPTION.....	4
1.2 RELATED SUBMITTAL(S) / GRANT (S) .....	4
1.3 TEST METHODOLOGY.....	4
1.4 SPECIAL ACCESSORIES .....	4
1.5 EQUIPMENT MODIFICATIONS .....	5
1.6 TEST FACILITY .....	6
<b>2. SYSTEM TEST CONFIGURATION .....</b>	<b>7</b>
2.1 EUT CONFIGURATION .....	7
2.2 EUT EXERCISE .....	7
2.3 TEST PROCEDURE.....	7
2.4 LIMITATION .....	7
2.5 CONFIGURATION OF TESTED SYSTEM.....	9
<b>3. SUMMARY OF TEST RESULTS .....</b>	<b>10</b>
<b>4. DESCRIPTION OF TEST MODES .....</b>	<b>10</b>
<b>5. CONDUCTED EMISSIONS TEST .....</b>	<b>11</b>
5.1 MEASUREMENT PROCEDURE:.....	11
5.2 TEST SET-UP (BLOCK DIAGRAM OF CONFIGURATION) .....	11
5.3 MEASUREMENT EQUIPMENT USED: .....	11
5.4 CONDUCTED EMISSION LIMIT .....	12
5.5 MEASUREMENT RESULT:.....	12
5.6 CONDUCTED MEASUREMENT PHOTOS:.....	15
<b>6. RADIATED EMISSION TEST .....</b>	<b>16</b>
6.1 MEASUREMENT PROCEDURE.....	16
6.2 TEST SET-UP (BLOCK DIAGRAM OF CONFIGURATION) .....	17
6.3 MEASUREMENT EQUIPMENT USED: .....	18
6.4 OUT OF BAND RADIATED MEASUREMENT RESULT .....	18
6.5 RADIATED MEASUREMENT PHOTOS:.....	22
<b>7. BAND EDGE.....</b>	<b>23</b>
<b>8. ANTENNA APPLICATION.....</b>	<b>25</b>
8.1 ANTENNA REQUIREMENT .....	25

## 1. General Information

### 1.1 Product Description

The ACCO Brands, Inc. Model: M01092-D (referred to as the EUT in this report) The EUT is an short range, lower power, Pro Fit™ 2.4GHz Wireless USB Dongle. designed as an " Input Device. It is designed by way of utilizing the GFSK modulation achieves the system operating.

A major technical descriptions of EUT is described as following:

- A) Operation Frequency: 2418-2463MHz
- B) Modulation: GFSK
- C) Number of Channel: 16 channels
- D) Antenna Designation: Integral
- E) Power Supply: DC 5V

Channel frequency:

Channel	Frequency (MHz)	Channel	Frequency (MHz)	Channel	Frequency (MHz)
1	2418	7	2436	13	2454
2	2421	8	2439	14	2457
3	2424	9	2442	15	2460
4	2427	10	2445	16	2463
5	2430	11	2448		
6	2433	12	2451		

### 1.2 Related Submittal(s) / Grant (s)

This submittal(s) (test report) is intended for FCC ID: GV3M01092-D filing to comply with Section 15.249 of the FCC Part 15, Subpart B and Subpart C Rules, The composite system (receiver) is compliance with Subpart B is authorized under a DoC procedure.

### 1.3 Test Methodology

Both conducted and radiated testing were performed according to the procedures in ANSI C63.4 (2003). Radiated testing was performed at an antenna to EUT distance 3 meters.

### 1.4 Special Accessories

Not available for this EUT intended for grant.

## **1.5 Equipment Modifications**

Not available for this EUT intended for grant.

## 1.6 Test Facility

Site Description  
EMC Lab. : Accredited by CNAS, 2005.11.02  
The certificate is valid until 2010.11  
The Laboratory has been assessed and proved to be in compliance  
with CNAS/CL01:2006(identical to ISO/IEC17025:2005)  
The Certificate Registration Number is L2291

Accredited by TUV Rheinland Shenzhen, 2009,9  
The certificate is valid until 2011,3  
The Laboratory has been assessed according to the requirements  
ISO/IEC 17025

Accredited by FCC, Nov. 05, 2008  
The Certificate Registration Number is 247565.

Accredited by Industry Canada, May 24, 2008  
The Certificate Registration Number is 46405-4480

Name of Firm : DONGGUAN EMTEK CO., LTD  
Site Location : No.281, Guantai Road, Nancheng District,  
Dongguan, Guangdong, China

## 2. System Test Configuration

### 2.1 EUT Configuration

The EUT configuration for testing is installed on RF field strength measurement to meet the Commissions requirement and operating in a manner which intends to maximize its emission characteristics in a continuous normal application.

### 2.2 EUT Exercise

The Transmitter was operated in the normal operating mode. the Tx frequency was fixed which was for the purpose of the measurements.

### 2.3 Test Procedure

#### 2.3.1 Conducted Emissions

The EUT is a placed on as turn table which is 0.8 m above ground plane. According to the requirements in Section 13.1.4.1 of ANSI C63.4-2003. Conducted emissions from the EUT measured in the **frequency range between 0.15 MHz and 30MHz** using **CISPR Quasi-Peak and average detector mode**.

#### 2.3.2 Radiated Emissions

The EUT is a placed on as turn table which is 0.8 m above ground plane. The turn table shall rotate 360 degrees to determine the position of maximum emission level. EUT is set 3m away from the receiving antenna which varied from 1m to 4m to find out the highest emission. And also, each emission was to be maximized by changing the polarization of receiving antenna both horizontal and vertical. In order to find out the max. emission, the relative positions of this hand-held transmitter(EUT) was rotated through three orthogonal axes according to the requirements in Section 13.1.4.1 of ANSI C63.4-2003.

### 2.4 Limitation

#### (1) Conducted Emission

Frequency(MHz)	Quasi-peak	Average
0.15-0.5	66-56	56-46
0.5-5.0	56	46
5.0-30.0	60	50

**Note:**

1. The lower limit shall apply at the transition frequencies
2. The limit decreases in line with the logarithm of the frequency in the range of 0.15 to 0.50MHz.

**(2) Radiated Emissions FCC Rule: 15.249(a)**

FCC Part 15, Subpart C Section 15.249. The field strength of emissions from intentional radiators operated within these frequency bands shall comply with the following:

Frequency(MHz)	Filed Strength of Fundamental(at 3m)		Filed Strength of Harmonics(at 3m)	
	PEAK	AVERAGE	PEAK	AVERAGE
902-928	114	94	74.0	54.0
2400-2483.5	114	94	74.0	54.0
5725-5875	114	94	74.0	54.0
24000-24250	128	108	88.0	68.0

**Radiated Emissions**

**FCC Rule: 15.249(d)(e)**

FCC Part 15, Subpart C Section 15.209 limit of radiated emission for frequency below 1000GHz. The emissions from an intentional radiator shall not exceed the field strength level specified in the following table:

Frequency (MHz)	Field strength $\mu\text{V/m}$	Distance(m)	Field strength at 3m $\text{dB}\mu\text{V/m}$
30-88	100	3	40
88-216	150	3	43.5
216-960	200	3	46
Above 960	500	3	54

- Remark: 1. Emission level in  $\text{dB}\mu\text{V/m} = 20 \log(\text{uV/m})$   
 2. Measurement was performed at an antenna to the closed point of EUT distance of meters.

**FCC Part 15, Section 15.35(b) limit of radiated emission for frequency above 1000MHz**

Frequency(MHz)	Class A( $\text{dB}\mu\text{V/m}$ )(at 3m)		Class B( $\text{dB}\mu\text{V/m}$ )(at 3m)	
	PEAK	AVERAGE	PEAK	AVERAGE
Above 1000	80.0	60.0	74.0	54.0



## 2.5 Configuration of Tested System

**Fig. 2-1 Configuration of Tested System**



Table 2-1 Equipment Used in Tested System

Item	Equipment	Mfr/Brand	Model/Type No.	FCC ID	Series No.	Note
1.	Pro Fit™ 2.4GHz Wireless USB Dongle	N/A	M01092-D	GV3M01092-D	N/A	<b><i>EUT</i></b>

**Note:**

- (1) Unless otherwise denoted as EUT in 『Remark』 column , device(s) used in tested system is a support equipment.

### 3. Summary Of Test Results

<b>FCC Rules</b>	<b>Description Of Test</b>	<b>Result</b>
§15.207	Conducted Emission	Compliant
§15.249 (a),(b),(d),(e),§ 15.209	Radiated Emission	Compliant
§15.249	Band Edge	Compliant
§15.203	Antenna Requirement	Compliant

### 4. Description of test modes

The basic operation modes are:

1. Low Channel: TX 2418MHz
2. Middle Channel: TX 2442MHz
3. High Channel: TX 2463MHz

## 5. Conducted Emissions Test

### 5.1 Measurement Procedure:

1. The EUT was placed on a table, which is 0.8m above ground plane.
2. Maximum procedure was performed on the six highest emissions to ensure EUT compliance.
3. Repeat above procedures until all frequency measured was complete.

### 5.2 Test SET-UP (Block Diagram of Configuration)

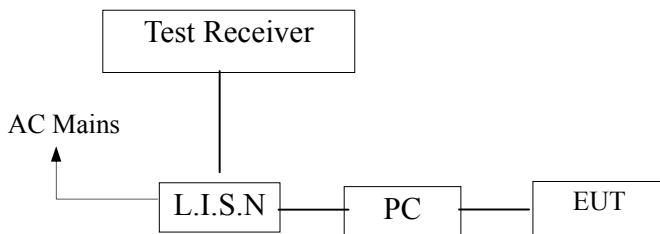

### 5.3 Measurement Equipment Used:

Conducted Emission Test Site # 4					
EQUIPMENT TYPE	MFR	MODEL NUMBER	SERIAL NUMBER	LAST CAL.	CAL DUE.
Test Receiver	Rohde & Schwarz	ESCS30	828985/018	05/29/2009	05/29/2010
L.I.S.N	Rohde & Schwarz	ESH2-Z5	834549/005	05/29/2009	05/29/2010
L.I.S.N	Rohde & Schwarz	ESH2-Z5	834549/005	05/29/2009	05/29/2010
50Ω Coaxial Switch	Anritsu	MP59B	M20531	005/29/2009	05/29/2010

#### 5.4 Conducted Emission Limit

##### (7) Conducted Emission

Frequency(MHz)	Quasi-peak	Average
0.15-0.5	66-56	56-46
0.5-5.0	56	46
5.0-30.0	60	50

**Note:**

1. The lower limit shall apply at the transition frequencies
2. The limit decreases in line with the logarithm of the frequency in the range of 0.15 to 0.50MHz.

#### 5.5 Measurement Result:

Dongguan EMTEK Co., Ltd.  
 No.281,Guantai Road, Nancheng District,Dongguan,Guangdong 523077 P.R. China  
 www.emtek.com.cn Tel:+86-769-2280 7078 Fax:+86-769-2280 7079



**Conducted Emission Measurement**

File :M01092-M Data :#1 Date: 2010/01/30 Time: 10:54:23

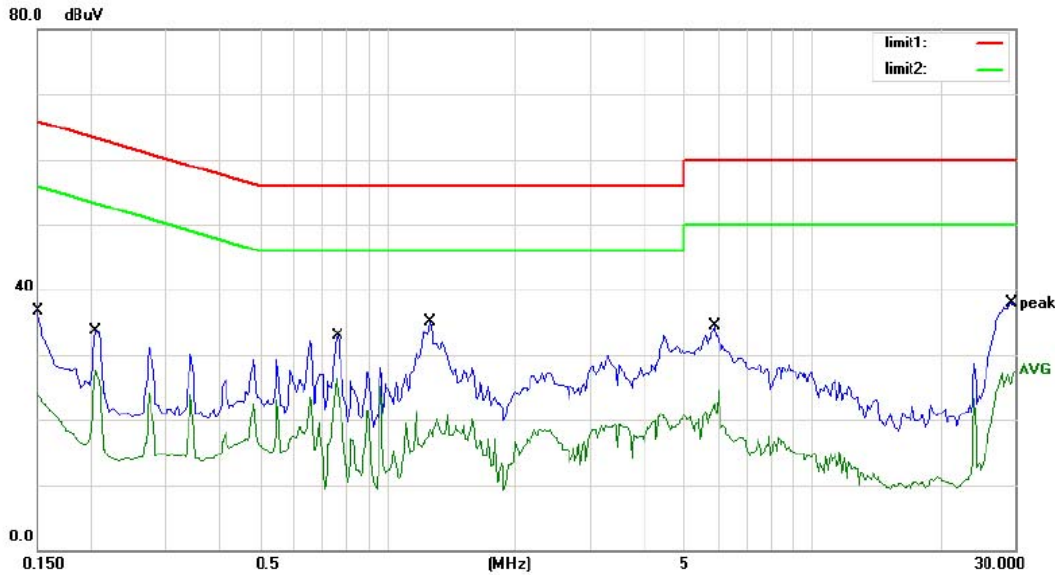

Site site #1 Phase: **L1** Temperature: 25  
 Limit: (CE)FCC PART 15 class B\_QP Power: AC 120V/60Hz Humidity: 50 %  
 EUT: Pro Fit™ 2.4GHz Wireless Mid-size Mouse.  
 M/N: M01092-D  
 Mode: Connect to PC  
 Note:

No.	Mk.	Freq. MHz	Reading Level dBuV	Correct Factor dB	Measure- ment dBuV	Limit dBuV	Over dB	Detector	Comment
1		0.1500	36.76	0.00	36.76	66.00	-29.24	QP	
2		0.1500	24.17	0.00	24.17	56.00	-31.83	AVG	
3		0.2050	33.79	0.00	33.79	63.41	-29.62	QP	
4		0.2050	27.79	0.00	27.79	53.41	-25.62	AVG	
5		0.7650	32.86	0.00	32.86	56.00	-23.14	QP	
6	*	0.7650	26.37	0.00	26.37	46.00	-19.63	AVG	
7		1.2650	35.02	0.00	35.02	56.00	-20.98	QP	
8		1.2650	18.43	0.00	18.43	46.00	-27.57	AVG	
9		5.8700	34.51	0.00	34.51	60.00	-25.49	QP	
10		5.8700	22.49	0.00	22.49	50.00	-27.51	AVG	
11		29.8500	37.88	0.00	37.88	60.00	-22.12	QP	
12		29.8500	27.52	0.00	27.52	50.00	-22.48	AVG	

Dongguan EMTEK Co., Ltd.  
 No.281,Guantai Road, Nancheng District,Dongguan,Guangdong 523077 P.R. China  
 www.emtek.com.cn Tel:+86-769-2280 7078 Fax:+86-769-2280 7079



**Conducted Emission Measurement**

File :M01092-M Data #2 Date: 2010/01/30 Time: 10:58:51

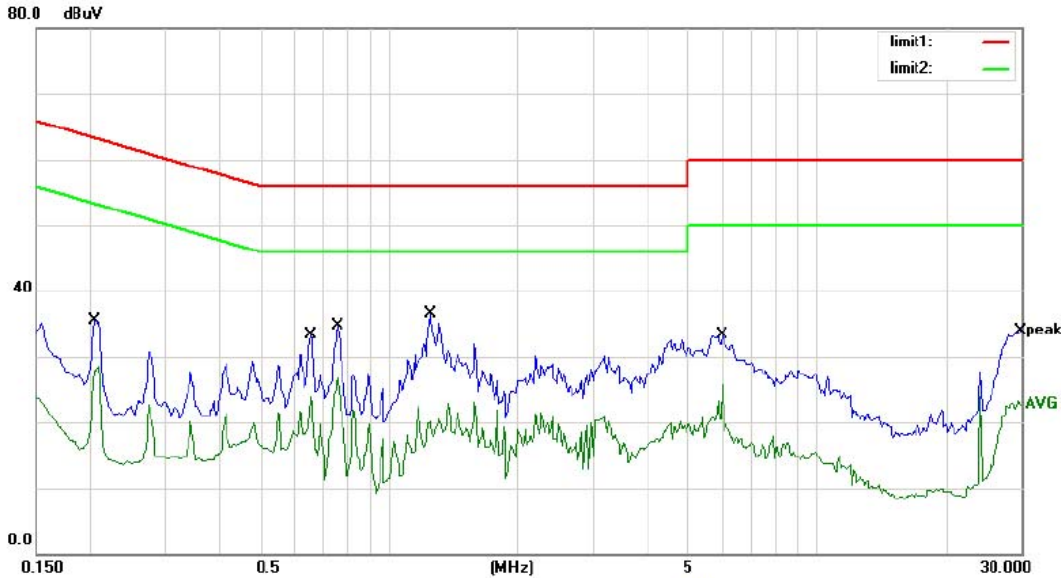

Site site #1 Phase: **N** Temperature: 25  
 Limit: (CE)FCC PART 15 class B\_QP Power: AC 120V/60Hz Humidity: 50 %  
 EUT: Pro FitTM 2.4GHz Wireless Mid-size Mouse.  
 M/N: M01092-D  
 Mode: Connect to PC  
 Note:

No.	Mk.	Freq. MHz	Reading Level dBuV	Correct Factor dB	Measure- ment dBuV	Limit dBuV	Over dB	Detector	Comment
1		0.2050	35.57	0.00	35.57	63.41	-27.84	QP	
2		0.2050	28.41	0.00	28.41	53.41	-25.00	AVG	
3		0.6600	33.28	0.00	33.28	56.00	-22.72	QP	
4		0.6600	23.89	0.00	23.89	46.00	-22.11	AVG	
5		0.7600	34.63	0.00	34.63	56.00	-21.37	QP	
6	*	0.7600	26.69	0.00	26.69	46.00	-19.31	AVG	
7		1.2500	36.52	0.00	36.52	56.00	-19.48	QP	
8		1.2500	20.11	0.00	20.11	46.00	-25.89	AVG	
9		6.0100	33.27	0.00	33.27	60.00	-26.73	QP	
10		6.0100	25.61	0.00	25.61	50.00	-24.39	AVG	
11		29.9250	33.94	0.00	33.94	60.00	-26.06	QP	
12		29.9250	23.29	0.00	23.29	50.00	-26.71	AVG	

**5.6 Conducted Measurement Photos:**



## **6. Radiated Emission Test**

### **6.1 Measurement Procedure**

1. The EUT was placed on a turn table which is 0.8m above ground plane.
2. Maximum procedure was performed on the six highest emissions to ensure EUT compliance.
3. And also, each emission was to be maximized by changing the polarization of receiving antenna both horizontal and vertical.
4. Repeat above procedures until all frequency measured were complete.



### 6.2 Test SET-UP (Block Diagram of Configuration)

(A) Radiated Emission Test Set-Up, Frequency Below 30MHz

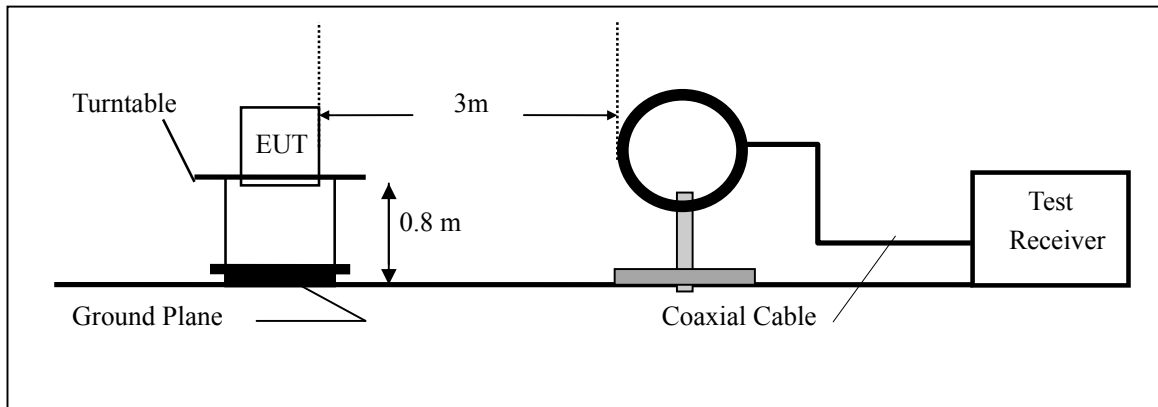

(B) Radiated Emission Test Set-Up, Frequency Below 1000MHz

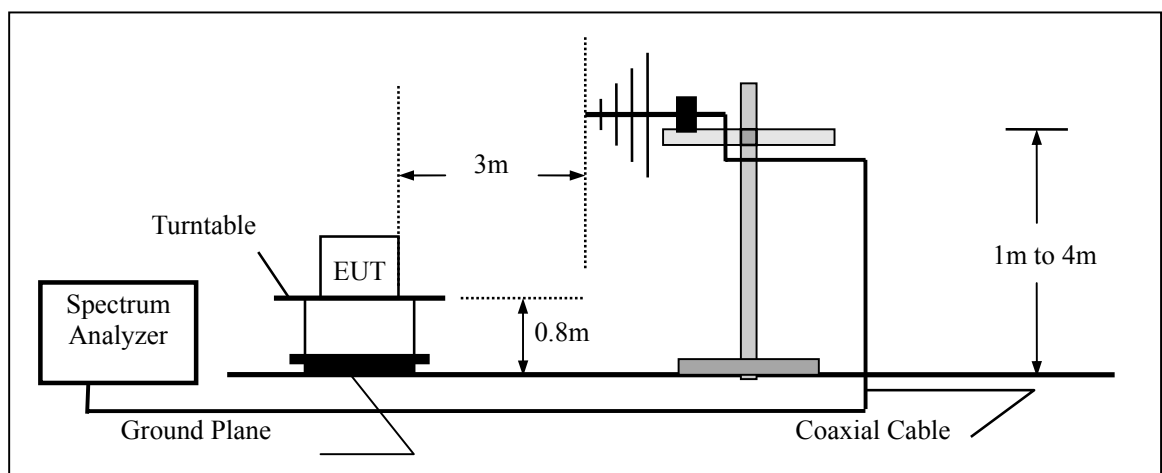

(C) Radiated Emission Test Set-Up, Frequency above 1000MHz

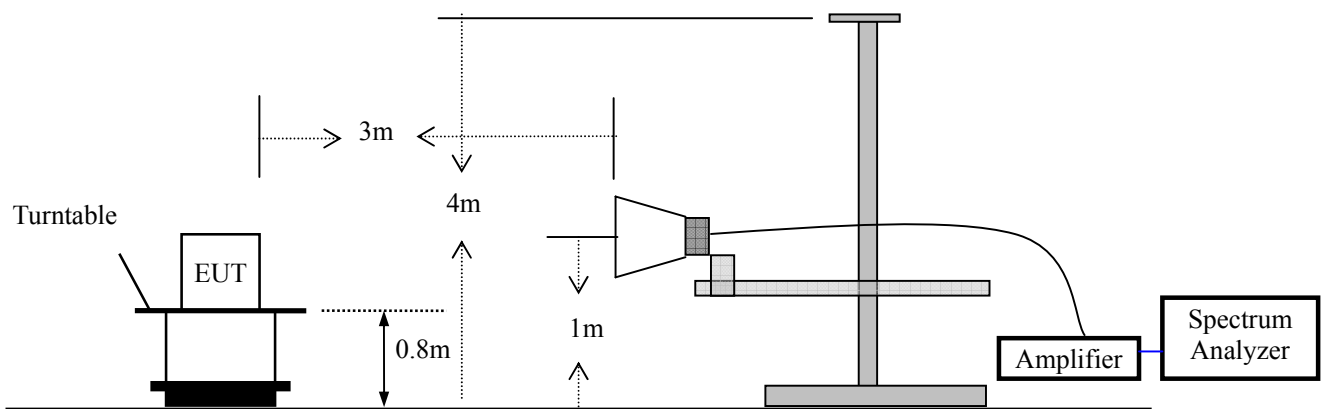

**6.3 Measurement Equipment Used:**

EQUIPMENT TYPE	MFR	MODEL NUMBER	SERIAL NUMBER	LAST CAL.	CAL DUE.
Spectrum Analyzer	Rohde & Schwarz	FSP7	839511/010	05/29/2009	05/29/2010
Spectrum Analyzer	HP	E4407B	839840481	05/29/2009	05/29/2010
EMI Test Receiver	Rohde & Schwarz	ESCS30	828985/018	05/29/2009	05/29/2010
Pre-Amplifier	HP	8447D	2944A07999	05/29/2009	05/29/2010
Bilog Antenna	Schwarzbeck	VULB9163	142	05/29/2009	05/29/2010
Loop Antenna	ARA	PLA-1030/B	1029	05/29/2009	05/29/2010
Horn Antenna	Electro-Metrics	EM-6961	103314	05/29/2009	05/29/2010
Horn Antenna	Schwarzbeck	BBHA 9120	D143	05/29/2009	05/29/2010

**6.4 Out of Band Radiated Measurement Result**

Operation Mode: TX Mode                      Test Date : March 30, 2010  
 Frequency Range: 30~1000MHz              Temperature : 23 °C  
 Test Result: PASS                              Humidity : 59 %  
 Measured Distance: 3m                        Test By: Andy

Freq. (MHz)	Ant.Pol. H/V	Emission Level (dBUV)	Limit 3m (dBUV/m)	Margin (dB)	Note
99.841	V	35.13	43.50	-8.37	QP
101.780	V	33.52	43.50	-9.98	QP
136.780	V	35.38	43.50	-8.12	QP
187.140	V	35.44	43.50	-8.06	QP
113.420	H	34.22	43.50	-9.28	QP
125.060	H	35.15	43.50	-8.35	QP
152.664	H	32.12	43.50	-11.38	QP
171.620	H	31.24	43.50	-12.26	QP

**Note:** (1) All Readings are QP Value.  
 (2) Emission Level= Reading Level+Probe Factor +Cable Loss  
 (3) The average measurement was not performed when the peak measured data under the limit of average detection.

**No others harmonics emissions are higher than 20dB below the limits of 47 CFR Part 15.209.**

Operation Mode: TX (2418MHz)      Test Date : March 30, 2010  
 Frequency Range: 1-25GHz      Temperature : 28 °C  
 Test Result: PASS      Humidity : 65 %  
 Measured Distance: 3m      Test By: Andy

Freq. (GHz)	Ant.Pol. H/V	Emission Level(dBuV)		Limit 3m(dBuV/m)		Margin(dB)	
		PK	AV	PK	AV	PK	AV
2.418(F)	V	78.96	69.54	114.00	94.00	-35.04	-24.46
4.836	V	52.42	40.26	74.00	54.00	-21.58	-13.74
7.254	V	50.24	41.74	74.00	54.00	-23.76	-12.26
9.672	V	51.38	42.20	74.00	54.00	-22.62	-11.80
12.090	V	55.26	41.78	74.00	54.00	-18.74	-12.22
2.418(F)	H	77.46	67.85	114.00	94.00	-36.54	-26.15
4.836	H	54.24	42.39	74.00	54.00	-19.76	-11.61
7.254	H	56.85	43.76	74.00	54.00	-17.15	-10.24
9.672	H	52.20	41.03	74.00	54.00	-21.80	-12.97
12.090	H	54.68	43.46	74.00	54.00	-19.32	-10.54

**No others harmonics emissions are higher than 20dB below the limits of 47 CFR Part 15.249.**

- Note:**
- (1) All Readings are Peak Value and AV.
  - (2) Emission Level= Reading Level+Probe Factor +Cable Loss
  - (3) The average measurement was not performed when the peak measured data under the limit of average detection.

Operation Mode: TX(2442MHz)      Test Date : March 30, 2010  
 Frequency Range: 1-25GHz      Temperature : 28 °C  
 Test Result: PASS      Humidity : 65 %  
 Measured Distance: 3m      Test By: Andy

Freq. (GHz)	Ant.Pol. H/V	Emission Level(dBuV)		Limit 3m(dBuV/m)		Margin(dB)	
		PK	AV	PK	AV	PK	AV
2.442(F)	V	77.43	68.38	114.00	94.00	-36.57	-25.62
4.884	V	49.51	41.68	74.00	54.00	-24.49	-12.32
7.326	V	47.95	40.88	74.00	54.00	-26.05	-13.12
9.768	V	46.51	39.51	74.00	54.00	-27.49	-14.49
12.210	V	45.97	38.82	74.00	54.00	-28.03	-15.18
2.442(F)	H	75.89	66.32	114.00	94.00	-38.11	-27.68
4.884	H	45.69	33.68	74.00	54.00	-28.31	-20.32
7.326	H	53.67	41.14	74.00	54.00	-20.33	-13.86
9.768	H	55.75	40.28	74.00	54.00	-18.25	-13.72
12.210	H	50.33	37.26	74.00	54.00	-23.67	-16.74

**No others harmonics emissions are higher than 20dB below the limits of 47 CFR Part 15.249.**

- Note:**
- (1) All Readings are Peak Value and AV.
  - (2) Emission Level= Reading Level+Probe Factor +Cable Loss
  - (3) The average measurement was not performed when the peak measured data under the limit of average detection.

Operation Mode: TX(2463MHz)                      Test Date : March 30, 2010  
 Frequency Range: 1-25GHz                      Temperature : 28 °C  
 Test Result: PASS                      Humidity : 65 %  
 Measured Distance: 3m                      Test By: Andy

Freq. (GHz)	Ant.Pol. H/V	Emission Level(dBuV)		Limit 3m(dBuV/m)		Margin(dB)	
		PK	AV	PK	AV	PK	AV
2.463(F)	V	77.52	68.91	114.00	94.00	-36.48	-25.09
4.926	V	62.15	47.28	74.00	54.00	-11.85	-6.72
7.389	V	53.45	42.15	74.00	54.00	-20.55	-11.85
9.852	V	45.72	34.26	74.00	54.00	-28.28	-19.74
12.315	V	53.44	46.20	74.00	54.00	-20.56	-7.80
2.463(F)	H	75.86	67.59	114.00	94.00	-38.14	-26.41
4.926	H	56.57	42.36	74.00	54.00	-17.43	-11.64
7.389	H	53.42	40.10	74.00	54.00	-20.58	-13.90
9.852	H	55.48	42.28	74.00	54.00	-18.52	-11.72
12.315	H	58.75	46.76	74.00	54.00	-15.25	-7.24

**No others harmonics emissions are higher than 20dB below the limits of 47 CFR Part 15.249.**

- Note:**
- (1) All Readings are Peak Value and AV.
  - (2) Emission Level= Reading Level+Probe Factor +Cable Loss
  - (3) The average measurement was not performed when the peak measured data under the limit of average detection.

**6.5 Radiated Measurement Photos:**

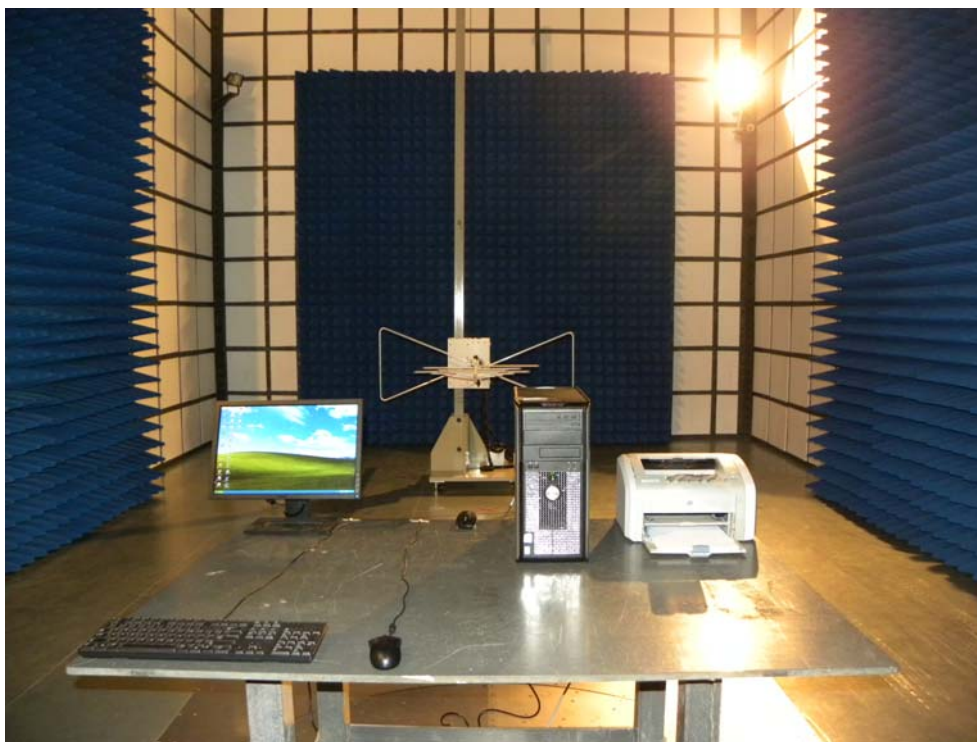

## **7. Band Edge**

### **7.1 Test limits**

Emissions radiated outside of the specified frequency bands, except for harmonics, shall be attenuated by at least 50 dB below the level of the fundamental or to the general radiated emission limits in Section 15.209, whichever is the lesser attenuation.

### **7.2 Measurement Procedure**

1. The EUT was placed on a turn table which is 0.8m above ground plane.
2. Set EUT as normal operation.
3. Set SPA Center Frequency=Fundamental frequency, RBW=100KHz, VBW=100KHz.
4. Set SPA Max hold. Mark peak.

### **7.3 Test SET-UP(Block Diagram of Configuration)**

Same as 6.2 Radiated Emission Measurement.

### **7.4 Measurement Equipment Used:**

Same as 6.3 Radiated Emission Measurement.

### **7.5 Measurement Results:**

PASS.

The test plots as following:

**Test Data:**

Low Channel

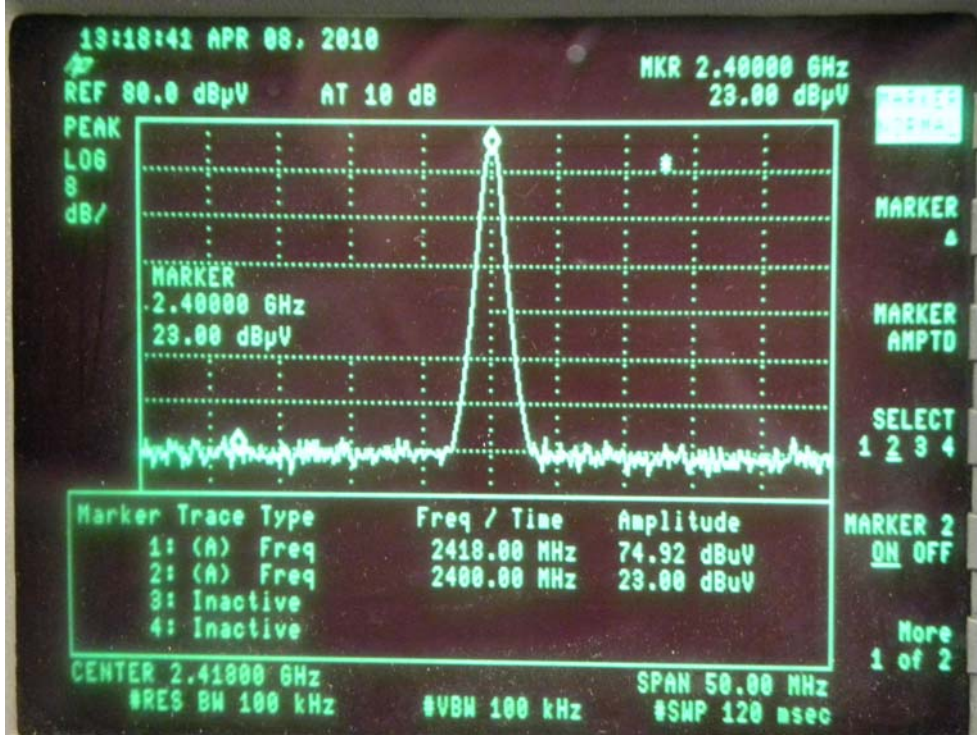

High Channel

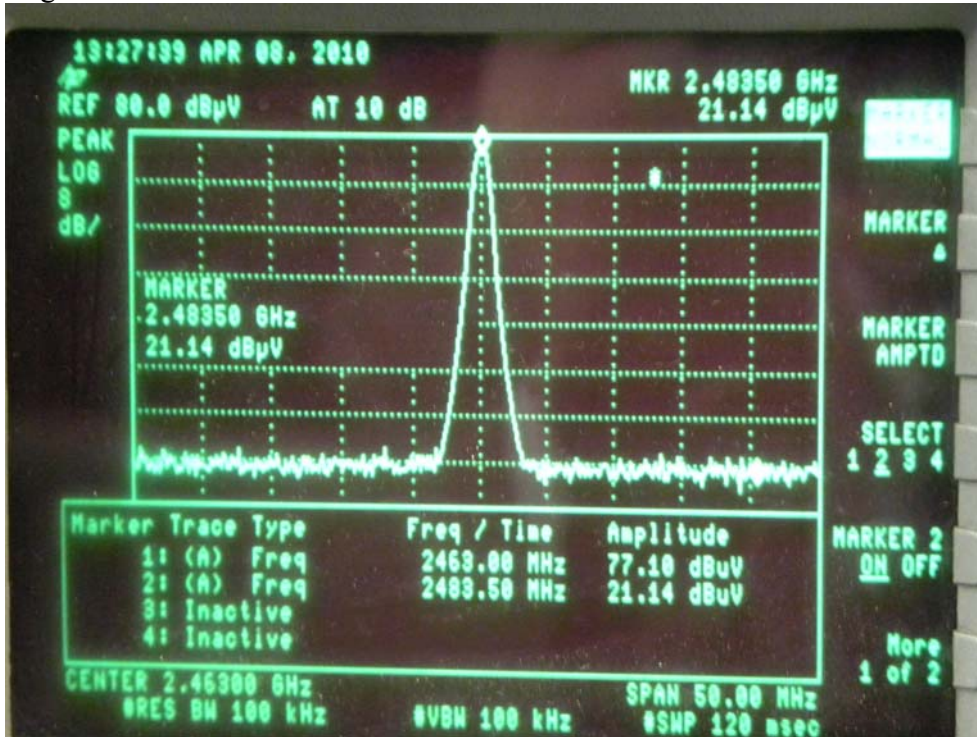



## **8. Antenna Application**

### **8.1 Antenna requirement**

The EUT'S antenna is met the requirement of FCC part 15C section 15.203 and 15.240.

According to Section 15.203, an intentional radiator shall be designed to ensure that no antenna other than that furnished by responsible party shall be used with the device.

The EUT's antenna used a chip antenna and integrated on PCB , this is permanently attached antenna and meets the requirements of this section.

### General Appearance of the EUT



