



Test Report

Product Name : LiquidAux Remote Controller
Model No. : M01013-R
FCC ID. : GV3M01013-R

Applicant : ACCO Brands, Inc.
Address : 333 Twin Dolphin Drive, 6th Floor ,Redwood
Shores,California,United States 94065

Date of Receipt : Jan. 28, 2008
Issued Date : Feb. 19, 2008
Report No. : 082006R-RFUSP07V01-A
Version : V1.0

The Test Results relate only to the samples tested.
The test report shall not be reproduced except in full without the written approval of Quietek Corporation.
This report must not be used to claim product endorsement by NVLAP any agency of the U.S. Government

Test Report Certification

Issued Date: Feb. 19, 2008

Report No. : 082006R-RFUSP07V01-A



Product Name : LiquidAux Remote Controller

Applicant : ACCO Brands, Inc.

Address : 333 Twin Dolphin Drive, 6th Floor ,Redwood Shores,California,United States 94065

Manufacturer : Darfon Electronics (Suzhou) Co., Ltd.

Model No. : M01013-R

FCC ID. : GV3M01013-R

Rated Voltage : DC 3V

Working Voltage : DC 3V

Trade Name : Kensington

Applicable Standard : FCC CFR Title 47 Part 15 Subpart C: 2007
ANSI C63.4: 2003

Test Result : Complied



The Test Results relate only to the samples tested.

The test report shall not be reproduced except in full without the written approval of Quietek Corporation.

This report must not be used to claim product endorsement by NVLAP any agency of the U.S. Government

Documented By : Leven Huang
(Adm. Specialist / Leven Huang)



Tested By : Molin Huang
(Engineer / Molin Huang)

Approved By : Vincent Lin
(Deputy Manager / Vincent Lin)



TABLE OF CONTENTS

Description	Page
1. GENERAL INFORMATION	4
1.1. EUT Description	4
1.2. Operation Description	5
1.3. Tested System Details	6
1.4. Configuration of Test System	6
1.5. EUT Exercise Software	6
1.6. Test Facility	7
2. Conducted Emission	8
2.1. Test Equipment	8
2.2. Test Setup	8
2.3. Limits	8
2.4. Test Procedure	9
2.5. Uncertainty	9
2.6. Test Result of Conducted Emission	10
3. Radiated Emission	11
3.1. Test Equipment	11
3.2. Test Setup	12
3.3. Limits	12
3.4. Test Procedure	13
3.5. Uncertainty	13
3.6. Test Result of Radiated Emission	14
4. Band Edge	17
4.1. Test Equipment	17
4.2. Test Setup	18
4.3. Limit	18
4.4. Test Procedure	19
4.5. Uncertainty	19
4.6. Test Result of Band Edge	20
5. EMI Reduction Method During Compliance Testing	22
Attachment 1: EUT Test Photographs	
Attachment 2: EUT Detailed Photographs	

1. GENERAL INFORMATION

1.1. EUT Description

Product Name : LiquidAux Remote Controller
Trade Name : Kensington
FCC ID. : GV3M01013-R
Model No. : M01013-R
Frequency Range : 2459MHz
Type of Modulation : GFSK
Number of Channels : 1
Channel Control : Auto
Antenna Type : Printed on PCB
Antenna Gain : -1.51 dBi

Frequency of Each Channel:

Channel	Frequency
Channel 1:	2459MHz

Note:

1. The EUT is a LiquidAux Remote Controller with a built-in 2.4GHz transceiver
2. These tests are conducted on a sample of the equipment for the purpose of demonstrating compliance with Part 15 Subpart C Paragraph 15.249.
3. Regarding to the operation frequency, the lowest, middle and highest frequency are selected to perform the test.
4. The radiation measurements are performed in X, Y, Z axis positioning. Only the worst case is shown in the report.

EMI Test Mode	Mode 1: Transmitter
---------------	---------------------

1.2. Operation Description

The EUT is LiquidAux Remote Controller with a built-in 2.4GHz transceiver. The EUT operation frequency is 2.459GHz. One channel is built in the EUT. The signals modulated by GFSK are transmitted from the printed antenna on the PCB of the EUT.

1.3. Tested System Details

The types for all equipment, plus descriptions of all cables used in the tested system (including inserted cards) are:

	Product	Manufacturer	Model No.	Serial No.	Power Cord
1.	Notebook P.C.	ASUS	L4000L	37NP067733	Shielded, 1.85m, with one core.
2.	Test Fixture	N/A	N/A	N/A	N/A
3.	Battery Box	N/A	N/A	N/A	N/A

	Signal Cable Type	Signal cable Description
A.	USB Cable	Shielded,1.2m
B.	Controller cable	Non-Shielded,0.3m
C.	Power cable	Shielded,0.5m

1.4. Configuration of Test System

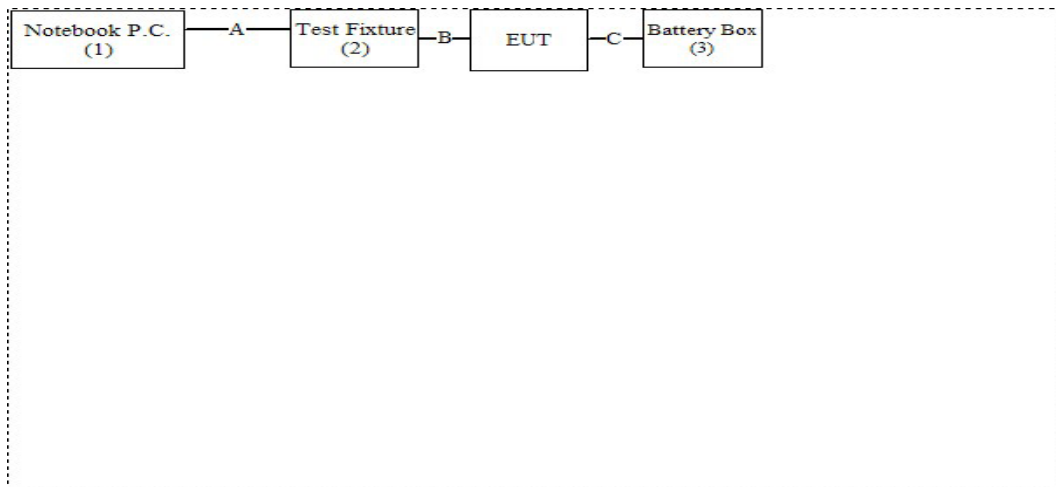

1.5. EUT Exercise Software

- (1) Connect the EUT to the notebook via a Test Fixture.
- (2) Provide DC 3V to the EUT.
- (3) Execute test software AVR Studio Ver.4.13 on the notebook.
- (4) Configure the test channel and the packet type.
- (5) Press OK to start the transmission.
- (6) Verify that the EUT works correctly.

1.6. Test Facility

Ambient conditions in the laboratory:

Items	Required (IEC 68-1)	Actual
Temperature (°C)	15-35	20-35
Humidity (%RH)	25-75	50-65
Barometric pressure (mbar)	860-1060	950-1000

Site Description: File on
 Federal Communications Commission
 FCC Engineering Laboratory
 7435 Oakland Mills Road
 Columbia, MD 21046
 Registration Number: 92195



Accreditation on NVLAP
 NVLAP Lab Code: 200533-0



Site Name: Quietek Corporation

Site Address: No. 5-22, Ruei-Shu Valley, Ruei-Ping Tsuen,
 Lin-Kou Shiang, Taipei,
 Taiwan, R.O.C.
 TEL: 886-2-8601-3788 / FAX : 886-2-8601-3789
 E-Mail : service@quietek.com

FCC Accreditation Number: TW1014



2. Conducted Emission

2.1. Test Equipment

The following test equipment are used during the conducted emission test:

Item	Instrument	Manufacturer	Type No./Serial No	Last Cal.	Remark
1	Test Receiver	R & S	ESCS 30/825442/17	May, 2007	
2	L.I.S.N.	R & S	ESH3-Z5/825016/6	May, 2007	EUT
3	L.I.S.N.	Kyoritsu	KNW-407/8-1420-3	May, 2007	Peripherals
4	Pulse Limiter	R & S	ESH3-Z2	May, 2007	
5	No.1 Shielded Room			N/A	

Note: All instruments are calibrated every one year.

2.2. Test Setup

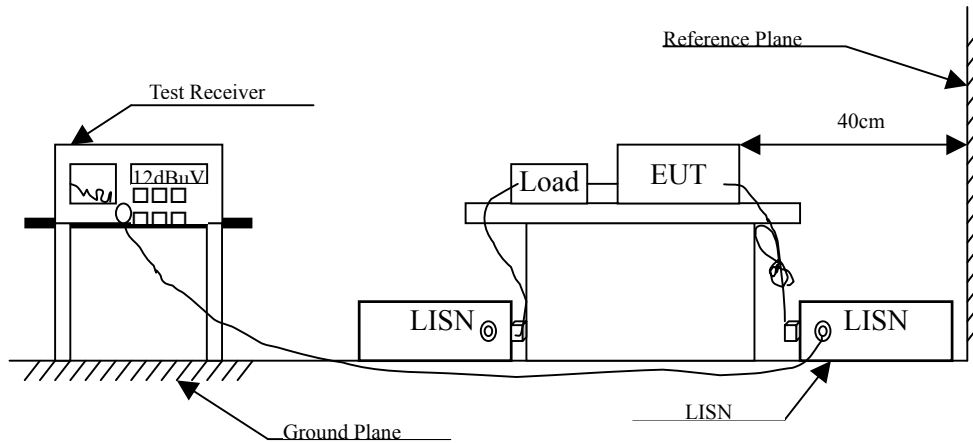

2.3. Limits

FCC Part 15 Subpart C Paragraph 15.207 (dBuV) Limit		
Frequency MHz	Limits	
	QP	AV
0.15 - 0.50	66-56	56-46
0.50-5.0	56	46
5.0 - 30	60	50

Remarks: In the above table, the tighter limit applies at the band edges.

2.4. Test Procedure

The EUT and simulators are connected to the main power through a line impedance stabilization network (L.I.S.N.). This provides a 50 ohm /50uH coupling impedance for the measuring equipment. The peripheral devices are also connected to the main power through a LISN that provides a 50ohm /50uH coupling impedance with 50ohm termination. (Please refers to the block diagram of the test setup and photographs.)

Both sides of A.C. line are checked for maximum conducted interference. In order to find the maximum emission, the relative positions of equipment and all of the interface cables must be changed according to ANSI C63.4: 2003 on conducted measurement.

Conducted emissions were investigated over the frequency range from 0.15MHz to 30MHz using a receiver bandwidth of 9kHz.

2.5. Uncertainty

± 2.26 dB

2.6. Test Result of Conducted Emission

The EUT is powered by batteries. This test item is not performed.

3. Radiated Emission

3.1. Test Equipment

The following test equipment are used during the radiated emission test:

Test Site		Equipment	Manufacturer	Model No./Serial No.	Last Cal.
<input type="checkbox"/> Site # 1		Test Receiver	R & S	ESVS 10 / 834468/003	May, 2007
		Spectrum Analyzer	Advantest	R3162/ 00803480	May, 2007
		Pre-Amplifier	Advantest	BB525C/ 3307A01812	May, 2007
		Bilog Antenna	SCHAFFNER	CBL6112B / 2697	Sep., 2007
<input type="checkbox"/> Site # 2		Test Receiver	R & S	ESCS 30 / 836858 / 022	May, 2007
		Spectrum Analyzer	Advantest	R3162 / 100803466	May, 2007
		Pre-Amplifier	Advantest	BB525C/3307A01814	May, 2007
		Bilog Antenna	SCHAFFNER	CBL6112B / 2705	May, 2007
		Horn Antenna	ETS	3115 / 0005-6160	Sep., 2007
		Pre-Amplifier	QTK	QTK-AMP-01/ 0001	May, 2007
<input checked="" type="checkbox"/> Site # 3	X	Test Receiver	R & S	ESI 26 / 838786/004	May, 2007
	X	Spectrum Analyzer	Agilent	E4407B / US39440758	May, 2007
	X	Bilog Antenna	SCHAFFNER	CBL6112B / 2697	May, 2007
	X	Horn Antenna	Schwarzbeck	BBHA9120D / 305, 306	July, 2007
	X	Horn Antenna	Schwarzbeck	BBHA9170 / 208, 209	July, 2007
	X	Pre-Amplifier	QTK	QTK-AMP-01 / 0001	July, 2007
	X	Pre-Amplifier	QTK	QTK-AMP-03 / 0003	May, 2007
	X	Pre-Amplifier	HP	8449B / 3008A01123	July, 2007

- Note:
1. All equipments are calibrated every one year.
 2. Test equipments marked by "X" are used to measure the final test results.

3.2. Test Setup

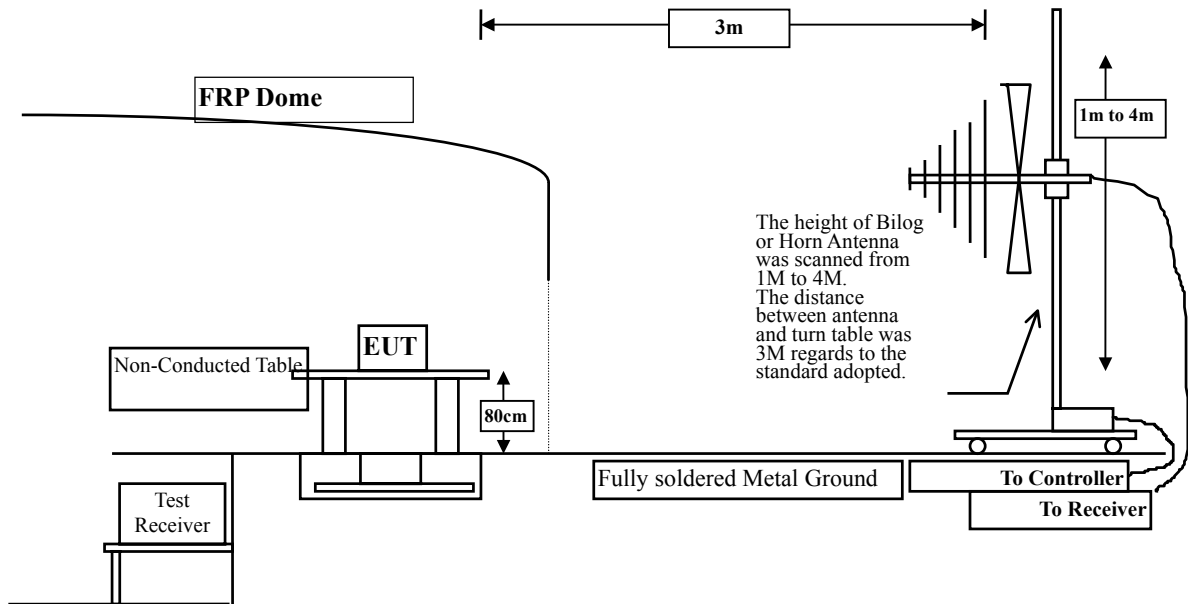

3.3. Limits

➤ Fundamental and Harmonics Emission Limits

FCC Part 15 Subpart C Paragraph 15.249 Limits				
Frequency MHz	Field Strength of Fundamental		Field Strength of Harmonics	
	(mV/m @3m)	(dBuV/m @3m)	(uV/m @3m)	(dBuV/m @3m)
902-928	50	94	500	54
2400-2483.5	50	94	500	54
5725-5875	50	94	500	54

- Remarks :
1. RF Voltage (dBuV/m) = 20 log RF Voltage (uV/m)
 2. Distance refers to the distance in meters between the measuring instrument antenna and the closed point of any part of the device or system.

➤ General Radiated Emission Limits

Emissions radiated outside of the specified frequency bands, except for harmonics, shall be attenuated by at least 50dB below the level of the fundamental or to the general radiated emission limits in paragraph 15.209, whichever is the lesser attenuation.

FCC Part 15 Subpart C Paragraph 15.209 Limits		
Frequency MHz	uV/m @3m	dBuV/m@3m
30-88	100	40
88-216	150	43.5
216-960	200	46
Above 960	500	54

- Remarks :
1. RF Voltage (dBuV/m) = 20 log RF Voltage (uV/m)
 2. In the Above Table, the tighter limit applies at the band edges.
 3. Distance refers to the distance in meters between the measuring instrument antenna and the closed point of any part of the device or system.

3.4. Test Procedure

The EUT and its simulators are placed on a turn table which is 0.8 meter above ground. The turn table can rotate 360 degrees to determine the position of the maximum emission level. The EUT was positioned such that the distance from antenna to the EUT was 3 meters.

The antenna can move up and down between 1 meter and 4 meters to find out the maximum emission level.

Both horizontal and vertical polarization of the antenna are set on measurement. In order to find the maximum emission, all of the interface cables must be manipulated according to ANSI C63.4: 2003 on radiated measurement.

Radiated emissions were investigated over the frequency range from 30MHz to 1GHz using a receiver bandwidth of 120kHz. Radiated was performed at an antenna to EUT distance of 3 meters.

The frequency range from 30MHz to 10th harmonics is checked.

3.5. Uncertainty

± 3.9 dB above 1GHz

± 3.8 dB below 1GHz

3.6. Test Result of Radiated Emission

Product : LiquidAux Remote Controller
 Test Item : Fundamental Radiated Emission
 Test Site : No.3OATS
 Test Mode : Mode 1: Transmitter

Frequency MHz	Correct Factor dB	Reading Level dBuV	Measurement Level dBuV/m	Margin dB	Limit dBuV/m
Horizontal					
Peak Detector:					
Channel 01					
2459.000	-2.047	78.510	76.463	-37.537	114.000
Average Detector					
--					
Vertical					
Peak Detector:					
Channel 01					
2459.000	-2.047	78.950	76.903	-37.097	114.000
Average Detector					
--					

Note:

1. Measurement Level = Reading Level + Correct Factor.
2. Correct Factor = Antenna Factor + Cable Loss – PreAMP.

Product : LiquidAux Remote Controller
 Test Item : Harmonic Radiated Emission Data
 Test Site : No.3 OATS
 Test Mode : Mode 1: Transmitter (2459 MHz)

Frequency MHz	Correct Factor dB	Reading Level dBuV	Measurement Level dBuV/m	Margin dB	Average Limit dBuV/m
Horizontal					
Peak Detector:					
4918.000	4.053	53.600	57.653	-16.317	74.000
7377.000	9.792	37.220	47.012	-26.958	74.000
9836.000	11.815	36.520	48.335	-25.635	74.000
Average Detector					
4918.000	4.053	32.710	36.763	-17.207	54.000
Vertical					
Peak Detector:					
4918.000	4.053	46.550	50.603	-23.367	74.000
7377.000	9.792	36.050	45.842	-28.128	74.000
9836.000	11.815	36.800	48.615	-25.355	74.000
Average Detector					
--					

Note:

1. All Readings below 1GHz are Quasi-Peak, above are performed with peak and/or average measurements as necessary.
2. Receiver setting (Peak Detector) : RBW:1MHz; VBW:1MHz; Span:100MHz ◦
3. Receiver setting (AVG Detector) : RBW:1MHz; VBW:30Hz; Span:20MHz ◦
4. Emission Level = Reading Level + Correct Factor.
5. The average measurement was not performed when the peak measured data under the limit of average detection. If the readings given are average, peak measurement should also be supplied.

Product : LiquidAux Remote Controller
 Test Item : General Radiated Emission Data
 Test Site : No.3 OATS
 Test Mode : Mode 1: Transmitter (2459 MHz)

Frequency	Correct	Reading	Measurement	Margin	Limit
	Factor	Level	Level		
MHz	dB	dBuV	dBuV/m	dB	dBuV/m
Horizontal					
249.220	13.141	15.592	28.733	-17.267	46.000
375.320	16.017	16.911	32.928	-13.072	46.000
549.920	20.181	9.935	30.116	-15.884	46.000
656.620	20.708	14.284	34.992	-11.008	46.000
749.740	21.030	9.892	30.922	-15.078	46.000
864.200	22.212	10.975	33.187	-12.813	46.000
Vertical					
249.220	13.116	18.397	31.513	-14.487	46.000
324.880	14.286	15.249	29.535	-16.465	46.000
454.860	18.669	9.521	28.190	-17.810	46.000
577.080	21.537	7.501	29.038	-16.962	46.000
747.800	23.164	4.014	27.178	-18.822	46.000
901.060	23.650	4.663	28.313	-17.687	46.000

Note:

1. All Readings below 1GHz are Quasi-Peak, above are performed with peak and/or average measurements as necessary.
2. "■" means the worst emission level.
3. Measurement Level = Reading Level + Correct Factor

4. Band Edge

4.1. Test Equipment

The following test equipments are used during the band edge tests:

	Equipment	Manufacturer	Model No./Serial No.	Last Cal.
X	Test Receiver	R & S	ESI 26 / 838786/004	May, 2007
X	Spectrum Analyzer	Agilent	E4407B / US39440758	May, 2007
X	Bilog Antenna	SCHAFFNER	CBL6112B / 2697	May, 2007
X	Horn Antenna	Schwarzbeck	BBHA9120D / 305, 306	July, 2007
X	Horn Antenna	Schwarzbeck	BBHA9170 / 208, 209	July, 2007
X	Pre-Amplifier	QTK	QTK-AMP-01 / 0001	July, 2007
X	Pre-Amplifier	QTK	QTK-AMP-03 / 0003	May, 2007
X	Pre-Amplifier	HP	8449B / 3008A01123	July, 2007

OATS No.3

- Note:
1. All equipments are calibrated every one year.
 2. The test equipments marked by "X" are used to measure the final test results.

4.2. Test Setup

RF Conducted Measurement:

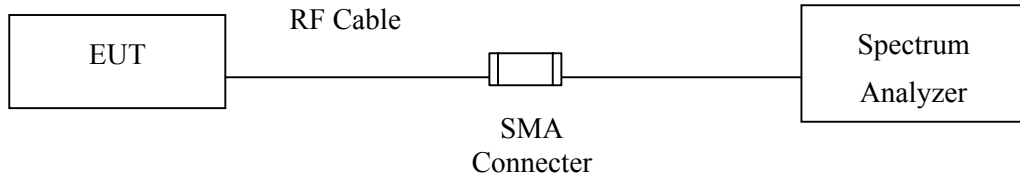

RF Radiated Measurement:

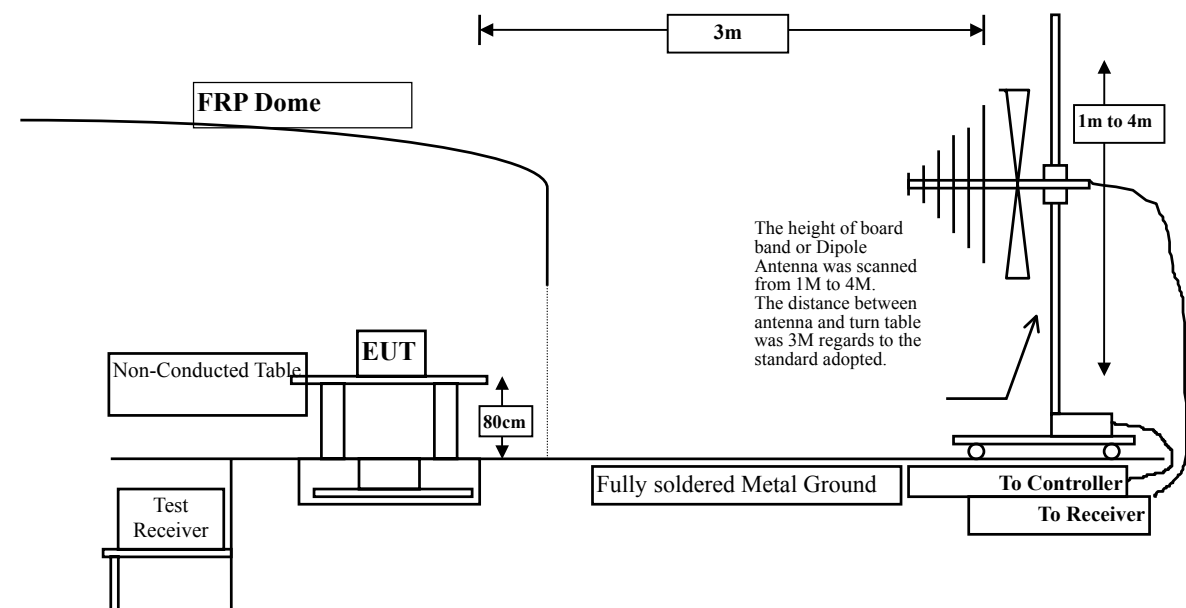

4.3. Limit

In any 100 kHz bandwidth outside the frequency band in which the spread spectrum intentional radiator is operating, the radio frequency power that is produced by the intentional radiator shall be at least 50 dB below that in the 100 kHz bandwidth within the band that contains the highest level of the desired power, based on either an RF conducted or a radiated measurement. Attenuation below the general limits specified in Section 15.209(a) is not required. In addition, radiated emissions which fall in the restricted bands, as defined in Section 15.205(a), must also comply with the radiated emission limits specified in Section 15.209(a) (see Section 15.205(c)).

4.4. Test Procedure

The EUT and its simulators are placed on a turn table which is 0.8 meter above ground. The turn table can rotate 360 degrees to determine the position of the maximum emission level. The EUT was positioned such that the distance from antenna to the EUT was 3 meters.

The antenna can move up and down between 1 meter and 4 meters to find out the maximum emission level.

Both horizontal and vertical polarization of the antenna are set on measurement. In order to find the maximum emission, all of the interface cables must be manipulated according to ANSI C63.4:2003 on radiated measurement.

The bandwidth below 1GHz setting on the field strength meter (R&S Test Receiver ESCS 30)is 120 kHz, above 1GHz are 1 MHz.

4.5. Uncertainty

Conducted is ± 1.27 dB

Radiated is ± 3.9 dB.

4.6. Test Result of Band Edge

Product : LiquidAux Remote Controller
 Test Item : Band Edge Data
 Test Site : No.3 OATS
 Test Mode : Mode 1: Transmitter (2459MHz)

RF Radiated Measurement (Horizontal):

Channel No.	Frequency (MHz)	Correct Factor (dB)	Reading Level (dBuV)	Emission Level (dBuV/m)	Peak Limit (dBuV/m)	Average Limit (dBuV/m)	Result
01(Peak)	2484.047	-1.935	39.737	37.802	74.000	54.000	Pass

Figure Channel 01: Horizontal

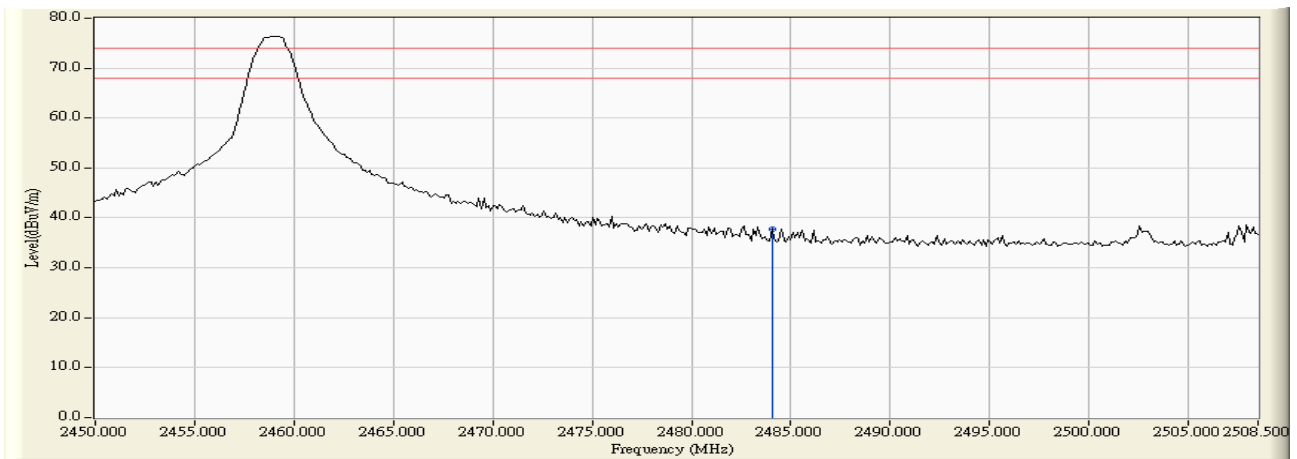

Note: RBW=1MHz, VBW=1MHz, Sweep Time=500ms

Product : LiquidAux Remote Controller
 Test Item : Band Edge Data
 Test Site : No.3 OATS
 Test Mode : Mode 1: Transmitter (2459MHz)

RF Radiated Measurement (Vertical):

Channel No.	Frequency (MHz)	Correct Factor (dB)	Reading Level (dBuV)	Emission Level (dBuV/m)	Peak Limit (dBuV/m)	Average Limit (dBuV/m)	Result
01(Peak)	2483.813	-1.936	40.235	38.299	74.000	54.000	Pass

Figure Channel 01: Vertical

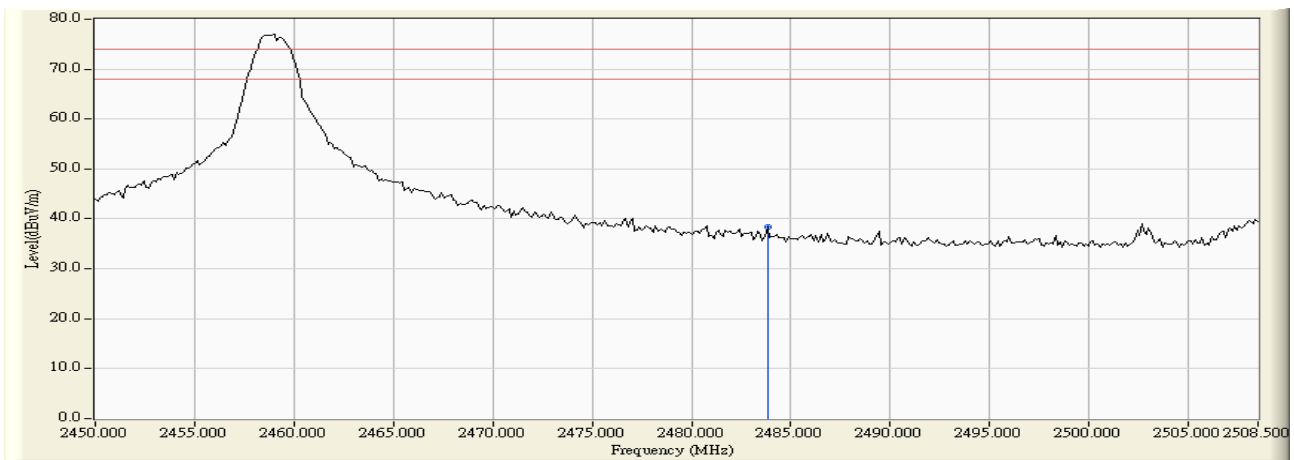

Note: RBW=1MHz, VBW=1MHz, Sweep Time=500ms

Note: The average measurement was not performed when the peak measured data under the limit of average detection. If the readings given are average, peak measurement should also be supplied.

5. EMI Reduction Method During Compliance Testing

No modification was made during testing.