

**ELECTROMAGNETIC EMISSIONS COMPLIANCE REPORT
INTENTIONAL RADIATOR CERTIFICATION TO
FCC PART 15 SUBPART C REQUIREMENT**

OF

RF MOUSE

MODEL No.: 72314

BRAND NAME: Kensington

FCC ID: GV372314

REPORT NO:SZ0411064

ISSUE DATE: December 11, 2004

Prepared for

**ACCO BRANDS,INC (KENSINGTON TECHNOLOGY GROUP)
2000 ALAMEDA DE LAS PULGAS 2nd FLOOR,SAN MATEO,CA 94403**

Prepared by

COMPLIANCE CERTIFICATION SERVICES (SHENZHEN) INC.

d.b.a.

**COMPLIANCE CERTIFICATION SERVICES (SHENZHEN) INC.
NO. 6, JINAO INDUSTRIAL PARK, NO. 35 JUKENG ROAD,
DASHUIKENG VILLAGE, GUANLAN TOWN, BAOAN
DISTRICT, SHENZHEN, CHINA**

TEL: 86-755-28055000

FAX: 86-755-28055221

VERIFICATION OF COMPLIANCE

Applicant:	ACCO BRANDS,INC (Kensington Technology Group) 2000 Alameda de las pulgas 2 nd Floor,San Mateo,CA 94403
Product Description:	RF Mouse
Brand Name:	Kensington
Model Number:	72314
Serial Number:	N/A
File Number:	SZE0411064
Date of Test:	November 29 ~ 30,2004

We hereby certify that:

The above equipment was tested by COMPLIANCE CERTIFICATION SERVICES (SHENZHEN) INC. The test data, data evaluation, test procedures, and equipment configurations shown in this report were made in accordance with the procedures given in ANSI C63.4 (2001) and the energy emitted by the sample EUT tested as described in this report is in compliance with conducted and radiated emission limits of FCC Rules Part 15.227.

The test results of this report relate only to the tested sample identified in this report.

Approved By

Clinton Kao / Q.A. Manager
**COMPLIANCE CERTIFICATION
SERVICES (SHENZHEN) INC.**

Reviewed By

Jimmy / Engineer
**COMPLIANCE CERTIFICATION
SERVICES (SHENZHEN) INC.**

Table of Contents

1. GENERAL INFORMATION 4

1.1 PRODUCT DESCRIPTION 4

1.2 RELATED SUBMITTAL(S) / GRANT (S)..... 4

1.3 TEST METHODOLOGY..... 4

1.4 TEST FACILITY 4

2. SYSTEM TEST CONFIGURATION 5

2.1 EUT CONFIGURATION..... 5

2.2 EUT EXERCISE..... 5

2.3 TEST PROCEDURE..... 5

2.4 LIMITATION..... 5

2.5 CONFIGURATION OF TESTED SYSTEM..... 7

3. SUMMARY OF TEST RESULTS 9

4. DESCRIPTION OF TEST MODES 9

5. CONDUCTED EMISSIONS TEST (NOT APPLICABLE IN THIS REPORT)..... 10

5.1 MEASUREMENT PROCEDURE: 10

5.2 TEST SET-UP (BLOCK DIAGRAM OF CONFIGURATION)..... 10

5.3 MEASUREMENT EQUIPMENT USED: 10

5.4 MEASUREMENT RESULT: 10

5.5 CONDUCTED MEASUREMENT PHOTOS:..... 10

6. RADIATED EMISSION TEST 11

6.1 MEASUREMENT PROCEDURE..... 11

6.2 TEST SET-UP (BLOCK DIAGRAM OF CONFIGURATION)..... 12

6.3 MEASUREMENT EQUIPMENT USED: 13

6.4 FIELD STRENGTH CALCULATION 13

6.5 MEASUREMENT RESULT..... 14

6.6 MEASUREMENT RESULT..... 15

7. OCCUPIED BANDWIDTH..... 16

7.1 MEASUREMENT PROCEDURE..... 16

7.2 TEST SET-UP (BLOCK DIAGRAM OF CONFIGURATION)..... 16

7.3 MEASUREMENT EQUIPMENT USED: 16

7.4 MEASUREMENT RESULTS:..... 16

APPENDIX 1

PHOTOGRAPHS OF SET UP 18

APPENDIX 2

PHOTOGRAPHS OF EUT..... 20

1. GENERAL INFORMATION

1.1 Product Description

The ACCO BRANDS, INC (Kensington Technology Group) Model: 72314 (referred to as the EUT in this report) The EUT is an short range, lower power, wireless mouse designed as an " Input Device. It is designed by way of utilizing the FSK modulation achieves the system operating.

A major technical descriptions of EUT is described as following:

- A). Operation Frequency: 27.04107 MHz, one channel.
- B). Modulation: Frequency Shifting Key (FSK) Modulation
- C). Antenna Designation: Non-User Replaceable (Fixed)
- D). Power Supply: 3 Vdc by AAA *2 battery.

1.2 Related Submittal(s) / Grant (s)

This submittal(s) (test report) is intended for FCC ID: GV372314 filing to comply with Section 15.227 of the FCC Part 15, Subpart C Rules. The composite system (receiver) is compliance with Subpart B is authorized under a DoC procedure.

1.3 Test Methodology

Both conducted and radiated testing were performed according to the procedures in ANSI C63.4 (2001). Radiated testing was performed at an antenna to EUT distance 3 meters.

1.4 Test Facility

The open area test site and conducted measurement facility used to collect the radiated data is located on the address of COMPLIANCE CERTIFICATION SERVICES (SHENZHEN) INC. No. 6, Jinao industrial park, No.35 Jukeng Road, Dashuikeng Village, Guanlan Town, Baoan District, Shenzhen, China. The Open Area Test Sites and the Line Conducted labs are constructed and calibrated to meet the FCC requirements in documents ANSI C63.4: 2001 and CISPR 22/EN 55022 requirements.

1.5 Special Accessories

Not available for this EUT intended for grant.

1.6 Equipment Modifications

Not available for this EUT intended for grant.

2. System Test Configuration

2.1 EUT Configuration

The EUT configuration for testing is installed on RF field strength measurement to meet the Commissions requirement and operating in a manner which intends to maximize its emission characteristics in a continuous normal application.

2.2 EUT Exercise

The Transmitter was operated in the normal operating mode. the Tx frequency was fixed which was for the purpose of the measurements.

2.3 Test Procedure

2.3.1 Conducted Emissions (Not apply in the report)

The EUT is a placed on as turn table which is 0.8 m above ground plane. According to the requirements in Section 13.1.4.1 of ANSI C63.4-2001. Conducted emissions from the EUT measured in the **frequency range between 0.15 MHz and 30MHz** using **CISPR Quasi-Peak and average detector mode**.

2.3.2 Radiated Emissions

The EUT is a placed on as turn table which is 0.8 m above ground plane. The turn table shall rotate 360 degrees to determine the position of maximum emission level. EUT is set 3m away from the receiving antenna which varied from 1m to 4m to find out the highest emission. And also, each emission was to be maximized by changing the polarization of receiving antenna both horizontal and vertical. In order to find out the max. emission, the relative positions of this hand-held transmitter(EUT) was rotated through three orthogonal axes according to the requirements in Section 13.1.4.1 of ANSI C63.4-2001.

2.4 Limitation

(1) Conducted Emission (Not applicable in this report)

According to section 15.207(a) Conducted Emission Limits is as following.

Frequency range MHz	Limits dB(uV)	
	Quasi-peak	Average
0.15 to 0.50	66 to 56	56 to 46
0.50 to 5	56	46
5 to 30	60	50
Note 1.The lower limit shall apply at the transition frequencies 2.The limit decreases linearly with the logarithm of the frequency in the range 0.15 MHz to 0.50 MHz.		

(2) Radiated Emission

- a. The field strength of any emission within this band (section 15.227 frequency between 26.96MHz -27.28MHz) shall not exceed 10000 micro volts/meter at 3 meters. (80dBµV at 3m) The emission limit in this paragraph is based on measurement instrumentation employing an average detector. The provisions in section 15.35 for limiting peak emissions apply.
- b. The field strength of any emissions which appear outside of this band shall not exceed the general radiated emission limits in section 15.209(Intentional Radiators general limit).as below.

Frequency (MHz)	Field strength µV/m	Distance(m)	Field strength at 3m dBµV/m
1.705-30	30	30	69.54
30-88	100	3	40
88-216	150	3	43.5
216-960	200	3	46
Above 960	500	3	54

- Remark:
- 1. Emission level in dBuV/m=20 log (uV/m)
 - 2. Measurement was performed at an antenna to the closed point of EUT distance of meters.
 - 3. Only spurious frequency is permitted to locate within the Restricted Bands specified in provision of § 15.205
 - 4. Emission spurious frequency which appearing within the Restricted Bands specified in provision of §15.205, then the general radiated emission limits in § 15.209 apply.

2.5 Configuration of Tested System

Fig. 2-1 Configuration of Tested System

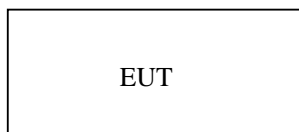

Table 2-1 Equipment Used in Tested System

Item	Equipment	Mfr/Brand	Model/Type No.	FCC ID	Series No.	Note
E-1	RF Mouse	Kensington	72314	GV372314	N/A	<i>EUT</i>

Note:

- (1) Unless otherwise denoted as EUT in 'Remark' column, device(s) used in tested system is a support equipment.

3. Summary Of Test Results

FCC Rules	Description Of Test	Result
§ 15.207	Conducted Emission	N/A
§ 15.227	Radiated Emission	Compliant
§ 15.227	26 dB Bandwidth	Compliant

4. Description of test modes

The EUT (RF MOUSE) has been tested under normal operating condition.

The EUT stay in continuous transmitting mode.

5. Conducted Emissions Test (Not applicable in this report)**5.1 Measurement Procedure:**

1. The EUT was placed on a table which is 0.8m above ground plane.
2. Maximum procedure was performed on the six highest emissions to ensure EUT compliance.
3. Repeat above procedures until all frequency measured were complete.

5.2 Test SET-UP (Block Diagram of Configuration)**5.3 Measurement Equipment Used:**

Conducted Emission Test Site # 4					
EQUIPMENT TYPE	MFR	MODEL NUMBER	SERIAL NUMBER	LAST CAL.	CAL DUE.
EMI TEST RECEIVER	HP	8546A	3448A00232	06/08/2004	06/07/2005
Spectrum Analyzer	ADVANTENT	R3132	N/A	06/08/2004	06/07/2005
LISN	EMCO	3825/2	1371	02/27/2004	02/26/2005
LISN	EMCO	3825/2	8901-1459	02/27/2004	02/26/2005

5.4 Measurement Result:**N/A****5.5 Conducted Measurement Photos:****N/A**

6. Radiated Emission Test

6.1 Measurement Procedure

1. The EUT was placed on a turn table which is 0.8m above ground plane.
2. Maximum procedure was performed on the six highest emissions to ensure EUT compliance.
3. And also, each emission was to be maximized by changing the polarization of receiving antenna both horizontal and vertical.
4. Repeat above procedures until all frequency measured were complete.

6.2 Test SET-UP (Block Diagram of Configuration)

(A) Radiated Emission Test Set-Up, Frequency Below 30MHz

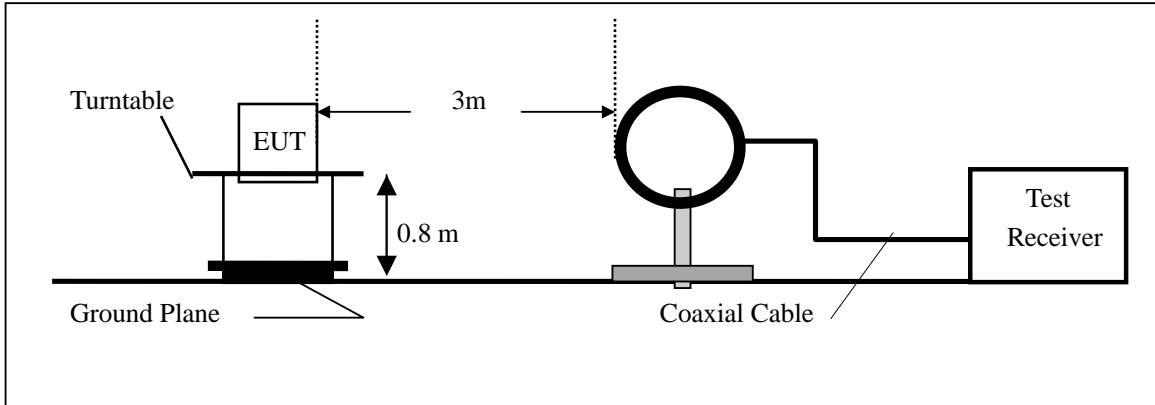

(B) Radiated Emission Test Set-Up, Frequency Below 1000MHz

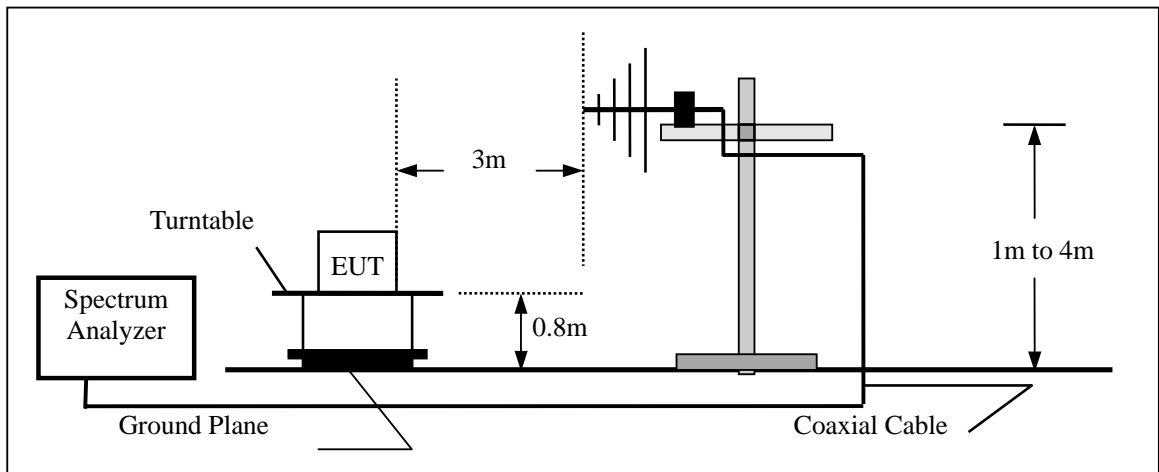

6.5 Measurement Result

Operation Mode: Transmitting Mode Test Date : November 29, 2004
Fundamental Frequency: 27.041 MHz Test By: Jimmy
Temperature : 23 Pol: Vertical
Humidity : 60 %
Judgement : Passed by -23.02 dB at 53.625 MHz Ant.Pol. Ver.

Freq. (MHz)	Ant.Pol. H/V	DetectorMode (PK/AV)	Reading (dBUV)	Ant./CL/ Amp. CF(dB)	Actual FS (dBUV/m)	Limit3m (dBUV/m)	Safe Margin (dB)	Note
27.041	V	Peak	45.64	23.27	68.91	80.00	-11.09	F
54.082	V	Peak	6.83	10.15	16.98	40.00	-23.02	H
81.123	V	Peak	7.28	7.69	14.97	40.00	-25.03	H
108.164	V	Peak	4.33	13.38	17.71	43.50	-25.79	H
135.205	V	Peak	4.14	11.70	15.84	43.50	-27.66	H
162.246	V	Peak	5.86	13.02	18.88	43.50	-24.62	H
189.287	V	Peak	3.65	14.93	18.58	43.50	-24.92	H
216.328	V	Peak	2.01	16.08	18.09	46.00	-27.91	H
243.369	V	Peak	3.14	18.02	21.16	46.00	-24.84	H
270.410	V	Peak	2.58	18.64	21.22	46.00	-24.78	H

Remark :

- (1) Measuring frequencies from 25 MHz to the 1GHz.
- (2) "F" denotes fundamental frequency; "H" denotes spurious frequency. "E" denotes band edge frequency.
- (3) * denotes emission frequency which appearing within the Restricted Bands specified in provision of 15.205, then the general radiated emission limits in 15.209 apply.
- (4) Datas of measurement within this frequency range shown " - " in the table above means the reading of emissions are attenuated more than 20dB below the permissible limits or the field strength is too small to be measured.
- (5) The IF bandwidth of SPA between 25MHz to 30MHz was 10KHz; 30MHz to 1GHz was 100KHz.

6.6 Measurement Result

Operation Mode: Transmitting Mode Test Date : November 29, 2004
 Fundamental Frequency: 27.041 MHz Test By: Jimmy
 Temperature : 23 Pol: Horizontal
 Humidity : 60 %
 Judgement: Passed by -20.50 dB at 54.082 MHz Ant.Pol. Hor.

(MHz)	H/V	(PK/AV)	(dBuV)	Amp. CF(dB)	(dBuV/m)	(dBuV/m)	(dB)	
27.041	H	Peak	37.46	23.27	60.73	80.00	-19.27	F
54.082	H	Peak	9.35	10.15	19.50	40.00	-20.50	H
81.123	H	Peak	8.26	7.69	15.95	40.00	-24.05	H
108.164	H	Peak	8.16	13.38	21.54	43.50	-21.96	H
135.205	H	Peak	10.33	11.70	22.03	43.50	-21.47	H
162.246	H	Peak	7.59	13.02	20.61	43.50	-22.89	H
189.287	H	Peak	5.29	14.93	20.22	43.50	-23.28	H
216.328	H	Peak	5.73	16.08	21.81	46.00	-24.19	H
243.369	H	Peak	3.45	18.02	21.47	46.00	-24.53	H
270.410	H	Peak	3.77	18.64	22.41	46.00	-23.59	H

Remark :

- (1) Measuring frequencies from 25 MHz to the 1GHz.
- (2) "F" denotes fundamental frequency; "H" denotes spurious frequency. "E" denotes band edge frequency.
- (3) * denotes emission frequency which appearing within the Restricted Bands specified in provision of 15.205, then the general radiated emission limits in 15.209 apply.
- (4) Datas of measurement within this frequency range shown " - " in the table above means the reading of emissions are attenuated more than 20dB below the permissible limits or the field strength is too small to be measured.
- (5) The IF bandwidth of SPA between 25MHz to 30MHz was 10KHz; 30MHz to 1GHz was 100KHz.

7. Occupied Bandwidth

7.1 Measurement Procedure

1. The EUT was placed on a turn table which is 0.8m above ground plane.
2. Set EUT as normal operation
3. Set SPA Center Frequency = fundamental frequency , RBW,VBW= 1KHz, Span =50KHz.
4. Set SPA Max hold. Mark peak, -26dB.

7.2 Test SET-UP (Block Diagram of Configuration)

Same as 4.2 Radiated Emission Measurement.

7.3 Measurement Equipment Used:

Same as 4.2 Radiated Emission Measurement.

7.4 Measurement Results:

26dB bandwidth = 4.5 KHz
Refer to attached data chart.

26dB Band Width Test Data

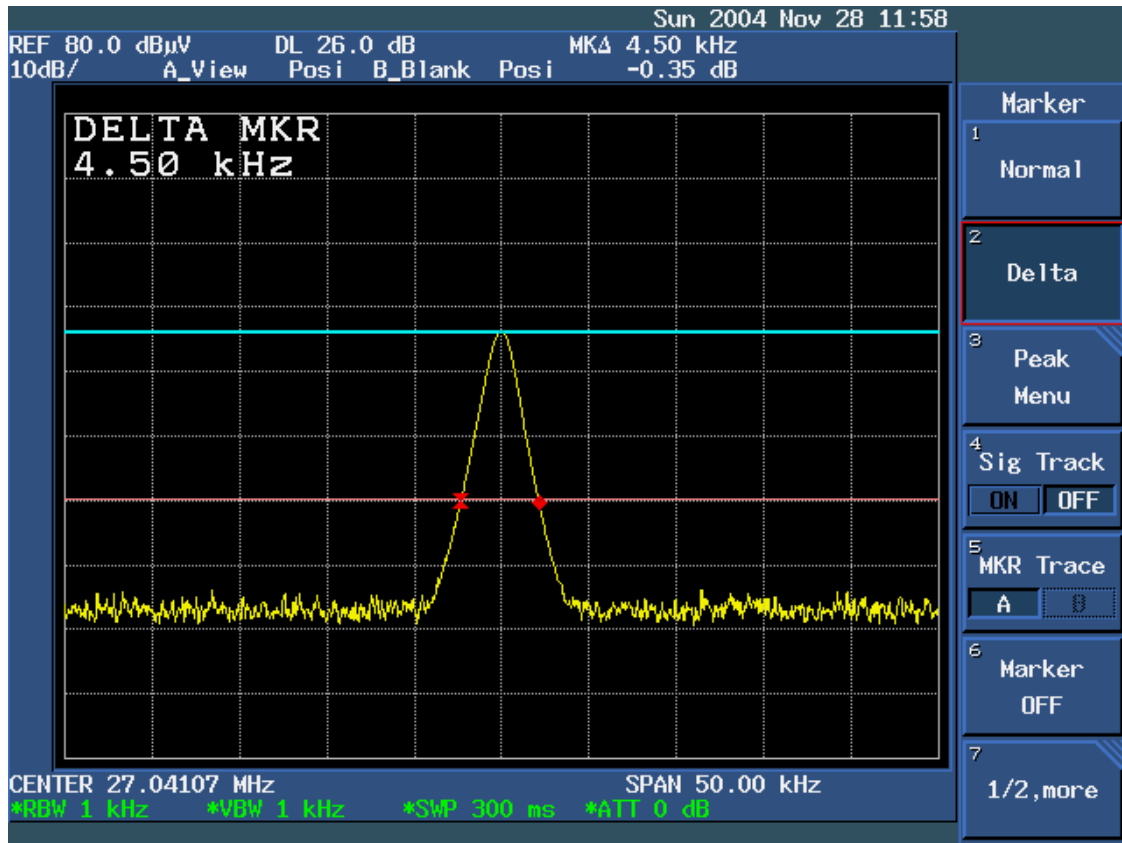

APPENDIX 1

PHOTOGRAPHS OF SET UP

Radiated Emission Setup Photos



APPENDIX 2

PHOTOGRAPHS OF EUT

Top View of TX



Bottom View of TX



Front View of TX



Back View of TX



Left View of TX



Right View of TX



Internal of TX-1



Internal of TX-2

