

ACCO Brands, Inc.

Air Purifier  
Z3000

In accordance with FCC Part 15 Subpart B

Prepared for: ACCO Brands, Inc.  
4 Corporate Drive Lake Zurich Illinois United States 60047



## COMMERCIAL-IN-CONFIDENCE

Report Number: 68.710.22.0166.01



China

Add value.  
Inspire trust.

RESPONSIBLE FOR	NAME	DATE	SIGNATURE
Approved by	John Zhi	2022/09/19	
Prepared by	Mark Chen	2022/09/19	

Signatures in this approval box have checked this document in line with the requirements of TÜV SÜD Product Service control rules.

### EXECUTIVE SUMMARY

A sample of this product was tested and found to be in compliance with FCC Part 15 Subpart B, 10-1-2021 — Information Technology Equipment (Including Digital Apparatus) — Limits and Methods of Measurement.

TÜV SÜD Certification and Testing  
(China) Co., Ltd. Shenzhen Branch

Building 12&13, Zhiheng  
Wisdomland Business Park,  
Nantou Checkpoint Road 2,  
Nanshan District, Shenzhen City,  
518052, P. R. China

Phone: +86 755 8828 6998  
Fax: +86 755 8828 5299  
[www.tuv-sud.cn](http://www.tuv-sud.cn)

TUV®

ID Number: GCN\_SR EMC\_TR\_001  
Revision:1.0  
Effective:2017-06-22

## Contents

<b>1</b>	<b>Report Summary .....</b>	<b>3</b>
1.1	Report Modification Record .....	3
1.2	Introduction .....	3
1.3	Brief Summary of Results .....	4
1.4	Product Information .....	5
1.5	Deviations from the Standard .....	5
1.6	Test Location .....	5
<b>2</b>	<b>Test Details.....</b>	<b>6</b>
2.1	Conducted Emission .....	6
2.2	Radiated Emission .....	10
<b>3</b>	<b>Test Equipment Information .....</b>	<b>16</b>
<b>4</b>	<b>Measurement Uncertainty.....</b>	<b>17</b>
<b>5</b>	<b>FCC Statements .....</b>	<b>18</b>

# 1 Report Summary

## 1.1 Report Modification Record

Alterations and additions to this report will be issued to the holders of each copy in the form of a complete document.

Issue	Description of Change	Date of Issue
1	First Issue	2022/09/19

## 1.2 Introduction

The information contained in this report is intended to show verification of the EMC Qualification Approval Testing of the requirements of the standards for the tests listed in Section 1.3.

Applicant	ACCO Brands, Inc.
Address	4 Corporate Drive Lake Zurich Illinois United States 60047
Manufacturer	ACCO Brands, Inc.
Address	4 Corporate Drive Lake Zurich Illinois United States 60047
Factory	Airplove (Xiamen) Electronic Co., Ltd.
Address	No.823, FangshanDong Er Road, Xiang'an District, Xiamen, China
Model Number(s)	Z3000
FCC ID:	GV3-22Z3000
Product Type	Air Purifier
Test Specification	FCC Part 15 Subpart B, 10-1-2021
Date of Receipt of EUT	2022-04-01
Start of Test	2022-07-20
Finish of Test	2022-07-20
Name of Engineer(s)	Mark Chen

### 1.3 Brief Summary of Results

A brief summary of the tests carried out in accordance with FCC Part 15 Subpart B is shown below.

Specification	Clause	Test Description	Result	Comments/Base Standard
FCC Part 15 Subpart B,10-1-2021 Edition	§15.107,	Conducted Emission	Pass	ANSI C63.4-2014
FCC Part 15 Subpart B,10-1-2021 Edition	§15.109,	Radiated Emission	Pass	ANSI C63.4-2014

**1.4 Product Information**

**1.4.1 Technical Description**

Ratings: : Air Purifier: 120VAC, 60Hz, 1.1A

**1.4.2 Test Configuration**

Configuration	Description
AC Powered	120VAC/60Hz

**1.4.3 Modes of Operation**

Mode	Description
Normal working(Max speed)	EUT is powered on and working in Normal working(Max)
Normal working(Min speed)	EUT is powered on and working in Normal working(Min)
Remark: The worst case was listed in this report.	

**1.5 Deviations from the Standard**

No deviations from the applicable test standard were made during testing.

**1.6 Test Location**

TÜV SÜD Certification and Testing (China) Co., Ltd. Shenzhen Branch

Address:

Building 12&13, Zhiheng Wisdomland Business Park,  
Nantou Checkpoint Road 2, Nantou, Nanshan District,  
Shenzhen Guangdong China 518052

Test Name	Name of Engineer(s)
Conducted Emission	Molly Mo
Radiated Emission	Felix Jiang

## 2 Test Details

### 2.1 Conducted Emission

#### 2.1.1 Specification Reference

FCC Part 15 Subpart B, 10-1-2021 Edition, Clause §15.107,

#### 2.1.2 Equipment Under Test

Z3000

#### 2.1.3 Date of Test

07/08/2022

#### 2.1.4 Test Method

The conducted emission shall be measured at the main terminals of the DECT Link equipment by means of the arrangement described in Figure 5 and 6 for the relevant type of equipment. The output terminals of the artificial mains network (V-network) and the terminals a-b shall be positioned  $0,8\text{m} \pm 20\%$  apart and shall be connected by the two power conductors of a flexible three-core cable of 0,8m length.

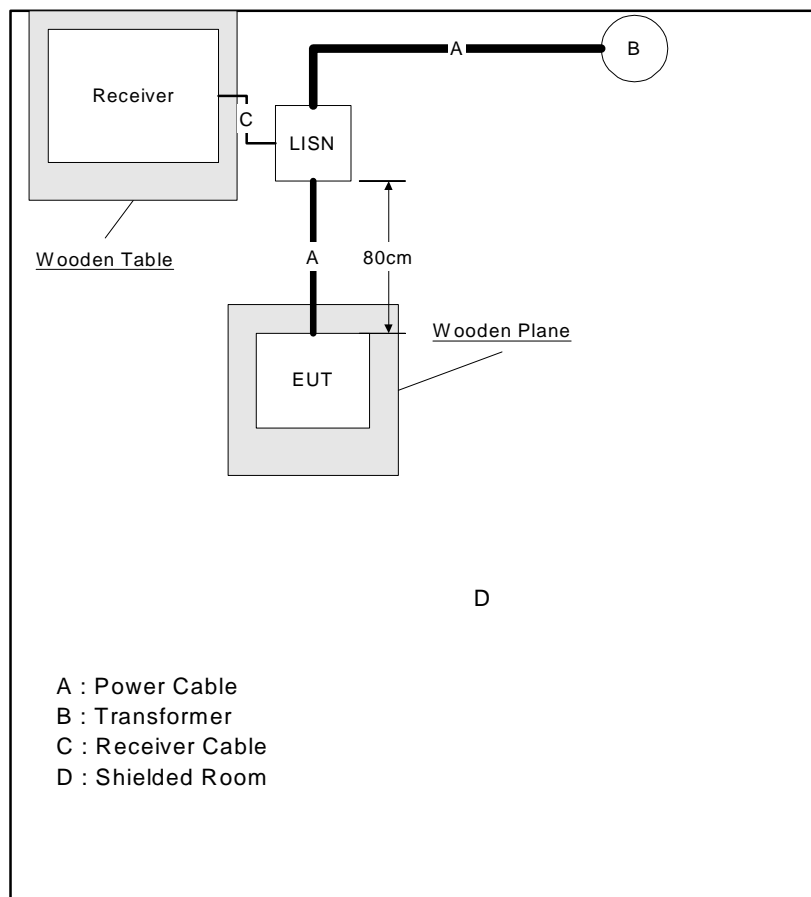

**2.1.5 Environmental Conditions**

Ambient Temperature	24.3°C
Relative Humidity	51.7%
Atmospheric Pressure	101.2mbar

**2.1.6 Specification Limits**

Conducted Emissions Limits		
Frequency range (MHz)	Limits dB(μV)	
	Quasi-peak	Average
0.15 – 0.5	66 to 56 (Note 2)	56 to 46 (Note 2)
0.5-5	56	46
5-30	60	50

Note 1: The more stringent limit applies at transition frequencies.  
 Note 2: The limit level in dBμV decreases linearly with the logarithm of frequency.

**2.1.7 Test Results**

M/N: Z3000  
 Op Cond.: Normal working(Max)  
 Comment: AC 120V/60Hz  
 Test Spec.: Power line, Live

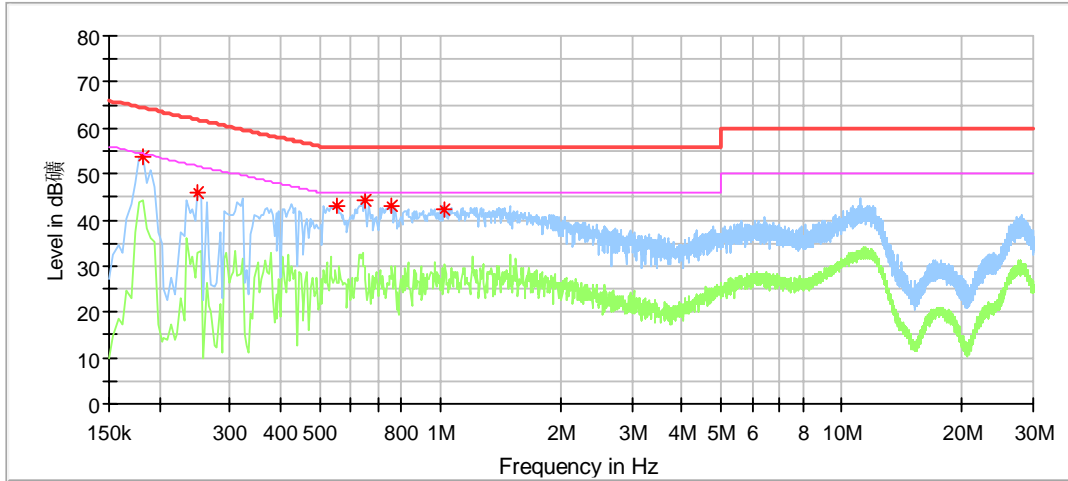

**Critical Freqs**

Frequency (MHz)	MaxPeak (dBµV)	Average (dBµV)	Limit (dBµV)	Margin (dB)	Line	Corr. (dB/m)
0.182000	53.74	---	64.39	10.65	L1	9.25
0.250000	45.82	---	61.76	15.94	L1	9.23
0.554000	42.89	---	56.00	13.11	L1	9.20
0.650000	44.13	---	56.00	11.87	L1	9.20
0.758000	43.19	---	56.00	12.81	L1	9.20
1.022000	42.30	---	56.00	13.70	L1	9.20

Remark:

Level=Reading Level + Correction Factor  
 Correction Factor=Cable Loss + LISN Factor  
 (The Reading Level is recorded by software which is not shown in the sheet)



M/N: Z3000  
 Op Cond.: Normal working(Max)  
 Comment: AC 120V/60Hz  
 Test Spec.: Power line, Neutral

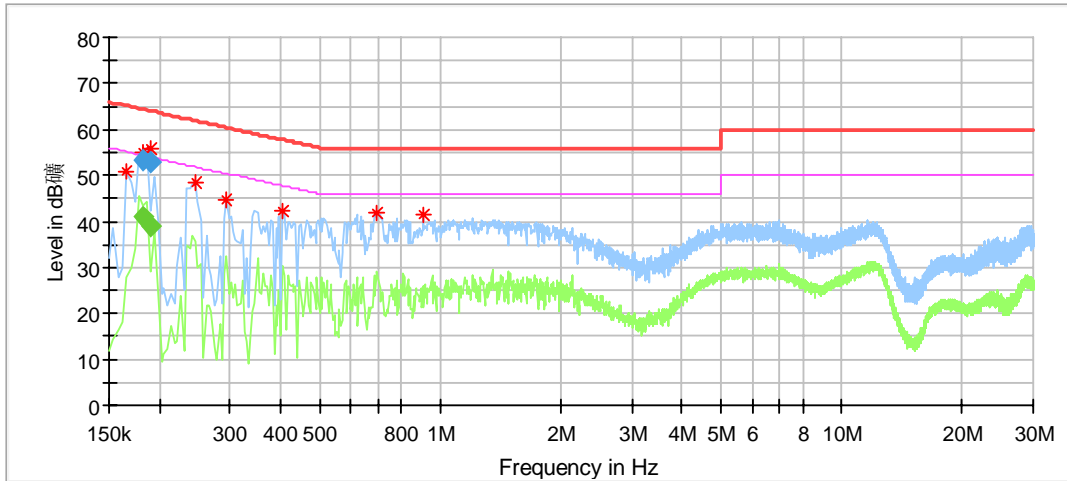

### Critical Freqs

Frequency (MHz)	MaxPeak (dBµV)	Average (dBµV)	Limit (dBµV)	Margin (dB)	Line	Corr. (dB/m)
0.166000	50.95	---	65.16	14.21	N	9.40
0.181500	55.07	---	64.58	9.51	N	9.40
0.190500	55.93	---	64.21	8.28	N	9.40
0.246000	48.33	---	61.89	13.56	N	9.39
0.294000	44.82	---	60.41	15.59	N	9.39
0.406000	42.16	---	57.73	15.57	N	9.38
0.698000	41.65	---	56.00	14.35	N	9.39
0.910000	41.55	---	56.00	14.45	N	9.39

### Final Result

Frequency (MHz)	QuasiPeak (dBµV)	Average (dBµV)	Limit (dBµV)	Margin (dB)	Line	Corr. (dB/m)
0.181500	---	41.08	54.42	13.34	N	9.40
0.181500	53.44	---	64.42	10.98	N	9.40
0.190500	---	38.99	54.02	15.02	N	9.40
0.190500	52.87	---	64.02	11.15	N	9.40

Remark:

Level=Reading Level + Correction Factor  
 Correction Factor=Cable Loss + LISN Factor  
 (The Reading Level is recorded by software which is not shown in the sheet)

**2.2 Radiated Emission**

**2.2.1 Specification Reference**

FCC Part 15 Subpart B, 10-1-2021 Edition, Clause §15.109,

**2.2.2 Equipment Under Test**

Z3000

**2.2.3 Date of Test**

08/12/2022

**2.2.4 Test Method**

The EUT was set up in a semi-anechoic chamber on a remotely controlled turntable and placed on a non-conductive table 0.8m above a reference ground plane. A pre-scan of the EUT emissions profile was made while varying the antenna-to-EUT azimuth and antenna-to-EUT polarization using a peak detector; measurements were taken at a 3m distance. Using the pre-scan list of the highest emissions detected, their bearing and associated antenna polarization, the EUT was then formally measured using a Quasi-Peak detector. The readings were maximized by adjusting the antenna height, polarization and turntable azimuth, in accordance with the specification.

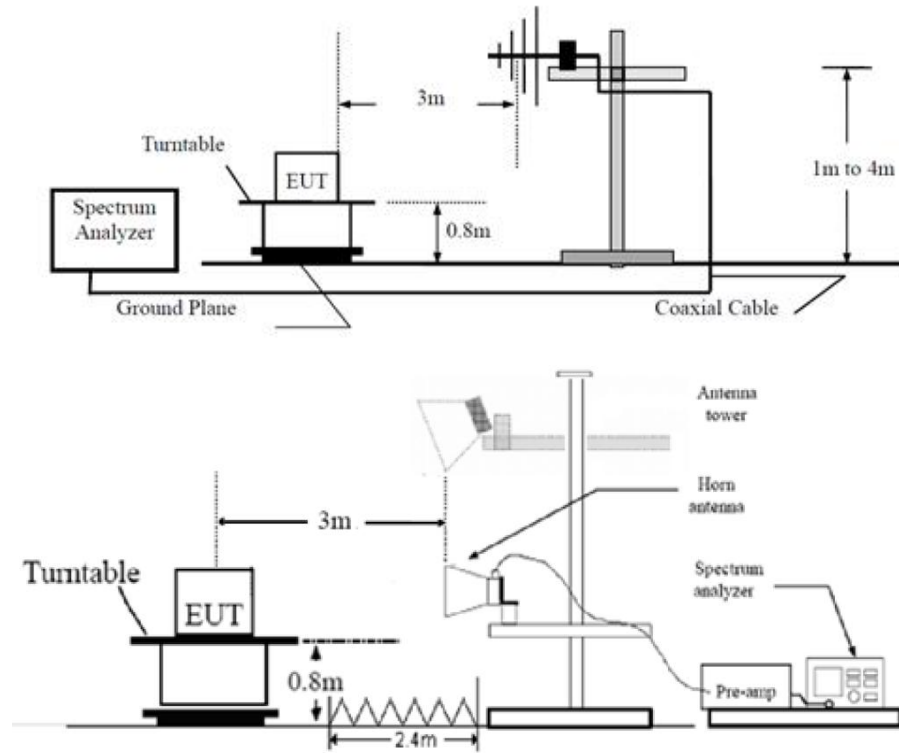

**2.2.5 Environmental Conditions**

Ambient Temperature	24.2°C
Relative Humidity	51.7%
Atmospheric Pressure	101.1 mbar

**2.2.6 Specification Limits**

Radiated emission limits in the frequency range 30MHz to 1000MHz at a measuring distance of 3 m	
Frequency range MHz	Quasi-peak limits dB(μV/m)
30-88	40
88-216	43.5
216-960	46
Above 960	54

Radiated emission limits in the frequency range 1000MHz to 6000MHz at a measuring distance of 3 m	
Frequency range MHz	Quasi-peak limits dB(μV/m)
1000-18000	74
Frequency range MHz	AV limits dB(μV/m)
1000-18000	54

### 2.2.7 Test Results

M/N: Z3000  
 Op Cond.: Normal working(Max)  
 Test Spec: Horizontal  
 Comment: 120VAC/60Hz

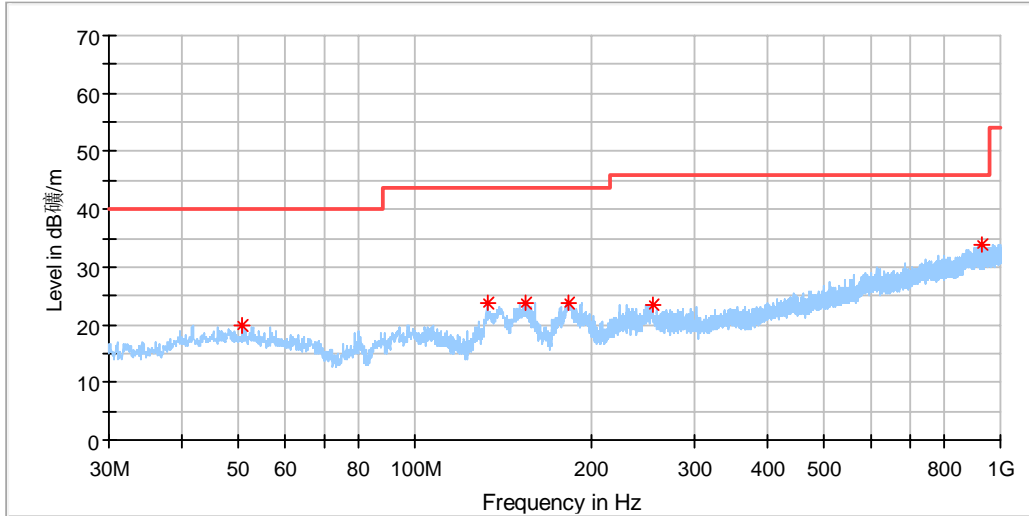

#### Critical Freqs

Frequency (MHz)	MaxPeak (dBµV/m)	Limit (dBµV/m)	Margin (dB)	Height (cm)	Pol	Azimuth (deg)	Corr. (dB/m)
50.855000	19.95	40.00	20.05	200.0	H	0.0	20.94
132.880625	23.67	43.50	19.83	200.0	H	67.0	15.62
154.038750	23.63	43.50	19.87	200.0	H	67.0	15.72
183.684375	23.81	43.50	19.69	100.0	H	177.0	17.44
255.464375	23.46	46.00	22.54	100.0	H	337.0	20.61
926.704375	33.73	46.00	12.27	200.0	H	330.0	32.69

Remark:

Level=Reading Level + Correction Factor

Correction Factor=Antenna Factor + Cable Loss

(The Reading Level is recorded by software which is not shown in the sheet)

M/N: Z3000  
 Op Cond.: Normal working(Max)  
 Test Spec: Vertical  
 Comment: 120VAC/60Hz

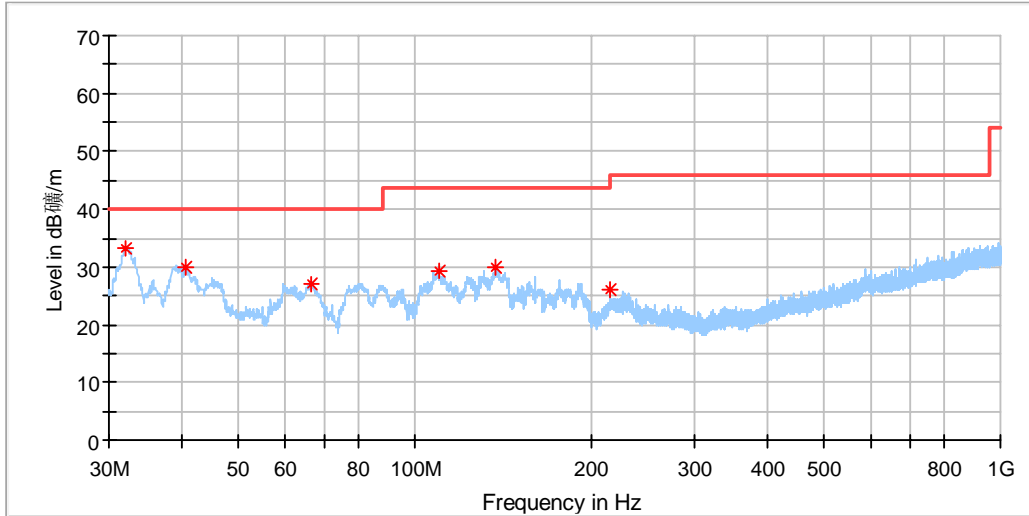

### Critical Freqs

Frequency (MHz)	MaxPeak (dBμV/m)	Limit (dBμV/m)	Margin (dB)	Height (cm)	Pol	Azimuth (deg)	Corr. (dB/m)
32.121875	33.37	40.00	6.63	100.0	V	209.0	17.16
40.670000	30.00	40.00	10.00	100.0	V	0.0	19.79
66.435625	27.09	40.00	12.91	100.0	V	0.0	18.47
109.903750	29.27	43.50	14.23	100.0	V	22.0	18.82
136.881875	29.89	43.50	13.61	100.0	V	22.0	15.55
215.694375	26.12	43.50	17.38	200.0	V	0.0	19.00

Remark:

Level=Reading Level + Correction Factor

Correction Factor=Antenna Factor + Cable Loss

(The Reading Level is recorded by software which is not shown in the sheet)

M/N: Z3000  
 Op Cond.: Normal working(Max)  
 Test Spec: Horizontal  
 Comment: 120VAC/60Hz

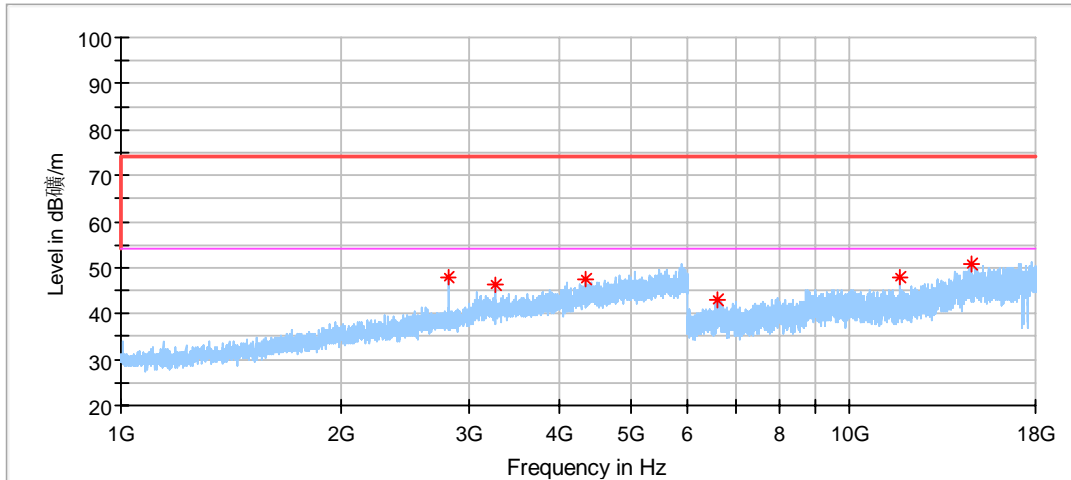

### Critical Freqs

Frequency (MHz)	MaxPeak (dBµV/m)	DET 2 (dBµV/m)	Limit (dBµV/m)	Margin (dB)	Height (cm)	Pol	Azimuth (deg)	Corr. (dB/m)
2816.000000	48.09	---	74.00	25.91	100.0	H	242.0	-4.28
3264.500000	46.35	---	74.00	27.65	100.0	H	95.0	-1.40
4357.000000	47.40	---	74.00	26.60	100.0	H	296.0	2.17
6606.000000	42.99	---	74.00	31.01	100.0	H	290.0	9.34
11740.500000	47.90	---	74.00	26.10	100.0	H	105.0	13.42
14661.500000	50.59	---	74.00	23.41	100.0	H	125.0	18.45

Remark:

Level=Reading Level + Correction Factor

Correction Factor=Antenna Factor + Cable Loss

(The Reading Level is recorded by software which is not shown in the sheet)

M/N: Z3000  
 Op Cond.: Normal working(Max)  
 Test Spec: Vertical  
 Comment: 120VAC/60Hz

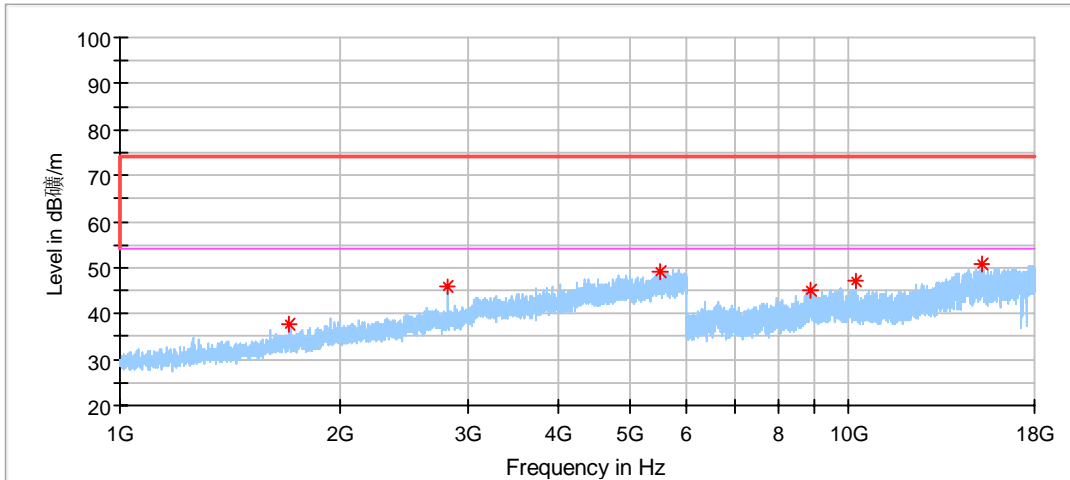

### Critical Freqs

Frequency (MHz)	MaxPeak (dBµV/m)	DET 2 (dBµV/m)	Limit (dBµV/m)	Margin (dB)	Height (cm)	Pol	Azimuth (deg)	Corr. (dB/m)
1710.500000	37.52	---	74.00	36.48	100.0	V	28.0	-9.51
2816.000000	45.87	---	74.00	28.13	100.0	V	289.0	-4.28
5510.500000	49.16	---	74.00	24.84	100.0	V	162.0	5.22
8861.500000	45.22	---	74.00	28.78	100.0	V	356.0	13.10
10245.500000	46.93	---	74.00	27.07	100.0	V	226.0	12.94
15231.500000	50.68	---	74.00	23.32	100.0	V	1.0	20.06

Remark:

Level=Reading Level + Correction Factor

Correction Factor=Antenna Factor + Cable Loss

(The Reading Level is recorded by software which is not shown in the sheet)

### 2.2.8 Test Location

This test was carried out in 3m anechoic chamber.

### 3 Test Equipment Information

#### Radiated Emission Test

Description	Manufacturer	Model no.	Equipment ID	Serial no.	cal interval (year)	cal. due date
EMI Test Receiver	Rohde & Schwarz	ESR 26	68-4-74-14-002	101269	1	2023-5-28
Trilog Super Broadband Test Antenna	Schwarzbeck	VULB 9162	68-4-80-19-003	284	1	2023-1-17
Wave Guide Antenna	ETS	3117	68-4-80-19-001	00218954	1	2023-5-9
Pre-amplifier	Rohde & Schwarz	SCU 18F	68-4-29-19-001	100745	1	2023-5-28
Pre-amplifier	Rohde & Schwarz	SCU 18F	68-4-29-19-002	100746	1	2023-5-28
Sideband Horn Antenna	Q-PAR	QWH-SL-18-40-K-SG	68-4-80-14-008	12827	1	2023-7-12
Pre-amplifier	Rohde & Schwarz	SCU 40A	68-4-29-14-002	100432	1	2023-7-27
Attenuator	Mini-circuits	UNAT-6+	68-4-81-21-002	15542	1	2023-5-27
3m Semi-anechoic chamber	TDK	SAC-3 #2	68-4-90-19-006	----	2	2023-5-28
Test software	Rohde & Schwarz	EMC32	68-4-90-19-006-A01	Version10.35.02	N/A	N/A

#### Conducted Emission Test

Description	Manufacturer	Model no.	Equipment ID	Serial no.	cal interval (year)	cal. due date
EMI Test Receiver	Rohde & Schwarz	ESR 3	68-4-74-14-001	101782	1	2023-5-27
LISN	Rohde & Schwarz	ENV4200	68-4-87-14-001	100249	1	2023-5-27
LISN	Rohde & Schwarz	ENV432	68-4-87-16-001	101318	1	2023-5-27
LISN	Rohde & Schwarz	ENV216	68-4-87-14-002	100326	1	2023-5-27
ISN	Rohde & Schwarz	ENY81	68-4-87-14-003	100177	1	2023-5-27
ISN	Rohde & Schwarz	ENY81-CA6	68-4-87-14-004	101664	1	2023-5-27
High Voltage Probe	Schwarzbeck	TK9420(VT9420)	68-4-27-14-001	9420-584	1	2023-5-27
RF Current Probe	Rohde & Schwarz	EZ-17	68-4-27-14-002	100816	1	2023-5-31
Attenuator	Shanghai Huaxiang	TS2-26-3	68-4-81-16-003	080928189	1	2023-5-27
Test software	Rohde & Schwarz	EMC32	68-4-90-14-003-A10	Version9.15.00	N/A	N/A
Shielding Room	TDK	CSR #1	68-4-90-19-004	----	1	2022-11-07



## 4 Measurement Uncertainty

For a 95% confidence level, the measurement uncertainties for defined systems are:

<b>System Measurement Uncertainty</b>	
Test Items	Extended Uncertainty
Uncertainty for Radiated Emission in 3m chamber 30MHz-1000MHz	Horizontal: 4.59dB; Vertical: 4.75dB;
Uncertainty for Radiated Emission in 3m chamber 1000MHz-18000MHz	Horizontal: 5.08dB; Vertical: 5.09dB;
Uncertainty for Conducted Emission 150kHz-30MHz (for test using AMN ENV432 or ENV4200)	3.15dB

## 5 FCC Statements

To whom it may concern,

We suggest you to put following statement in the label to the product, When the device is so small, or for such use that it is impracticable to label it with the required compliance statement in a font that is four-point or larger, and the device does not have a display that can show electronic labeling, then the information required shall be placed in the instruction manual, and on the device packaging or on a removable label attached to the device.

**This device complies with part 15 of the FCC Rules. Operation is subject to the following two conditions: (1) This device may not cause harmful interference, and (2) this device must accept any interference received, including interference that may cause undesired operation.**

The instruction manual shall include the following statement, placed in a prominent location in the text of the manual:

**For class B digital device:**

**NOTE: This equipment has been tested and found to comply with the limits for a Class B digital device, pursuant to part 15 of the FCC Rules. These limits are designed to provide reasonable protection against harmful interference in a residential installation. This equipment generates, uses and can radiate radio frequency energy and, if not installed and used in accordance with the instructions, may cause harmful interference to radio communications. However, there is no guarantee that interference will not occur in a particular installation. If this equipment does cause harmful interference to radio or television reception, which can be determined by turning the equipment off and on, the user is encouraged to try to correct the interference by one or more of the following measures:**

- Reorient or relocate the receiving antenna.
- Increase the separation between the equipment and receiver.
- Connect the equipment into an outlet on a circuit different from that to which the receiver is connected.
- Consult the dealer or an experienced radio/TV technician for help.

**MODIFICATION: Any changes or modifications not expressly approved by the grantee of this device could void the user's authority to operate the device.**

---THE END OF REPORT---