



### FCC - TEST REPORT

Report Number : **68.910.22.0012.01** Date of Issue: 2022-09-19

Model : SensorPod

Product Type : SensorPod

Applicant : ACCO Brands, Inc.

Address : 4 Corporate Drive Lake Zurich Illinois United States 60047

Manufacturer : ACCO Brands, Inc.

Address : 4 Corporate Drive Lake Zurich Illinois United States 60047

Test Result :  **Positive**     **Negative**

Total pages including Appendices : 22

Any use for advertising purposes must be granted in writing. This technical report may only be quoted in full. This report is the result of a single examination of the object in question and is not generally applicable evaluation of the quality of other products in regular production. For further details, please see testing and certification regulation chapter A-3.4.



# 1 Table of Contents

1 Table of Contents .....	2
2 Details about the Test Laboratory .....	3
3 Description of the Equipment Under Test .....	4
4 Summary of Test Standards .....	5
5 Summary of Test Results .....	6
6 General Remarks .....	7
7 Test setups .....	8
8 Technical Requirement .....	9
8.1 Conducted Emission .....	9
8.2 Field strength of emissions and Restricted bands .....	12
8.3 Out of Band Emissions .....	17
8.4 20dB Bandwidth & 99% Occupied Bandwidth .....	19
9 Test equipment lists .....	21
10 System Measurement Uncertainty .....	22



## 2 Details about the Test Laboratory

### Details about the Test Laboratory

#### Test Site 1

Company name: TÜV SÜD Certification and Testing (China) Co., Ltd. Shenzhen Branch  
Building 12&13, Zhiheng Wisdomland Business Park,  
Nantou Checkpoint Road 2, Nanshan District,  
Shenzhen City, 518052,  
P. R. China

FCC Registration Number: 514049

Telephone: 86 755 8828 6998  
Fax: 86 755 8828 5299



### 3 Description of the Equipment Under Test

#### Description of the Equipment Under Test

Product: SensorPod

Model no: SensorPod

FCC ID: GV3-22SP001

Options and accessories: NIL

Ratings: 9VDC, 0.5A (Supplied by AC/DC Adapter)

Adapter information  
 Model 1: IVP0900-0500W  
 Input: 100-240VAC, 50/60Hz, 0.5A  
 Output: 9VDC, 0.5A

Model 2: R062-0900500UC  
 Input: 100-240VAC, 50/60Hz, 0.3A  
 Output: 9VDC, 0.5A  
 The adaptors from two suppliers are with the same input and output parameters. Adaptor from same supplier share the same circuit and materials. Other differences are the model numbers and plug construction.

RF Transmission Frequency: 2462MHz

Antenna Type: PCB Antenna

Antenna Gain: 2.0dBi

Description of the EUT: The product is a SensorPod that operated at 2.4GHz, The TX and RX range is 2462MHz

#### Auxiliary Equipment Used during Test:

DESCRIPTION	MANUFACTURER	RATINGS	MODEL NO.
---	---	---	---



## 4 Summary of Test Standards

Test Standards	
FCC Part 15 Subpart C 10-1-2021 Edition	PART 15 - RADIO FREQUENCY DEVICES Subpart C - Intentional Radiators

All the test methods were according to ANSI C63.10-2013.



## 5 Summary of Test Results

Technical Requirements				
FCC Part 15 Subpart C 15.249				
Test Condition	Test Site	Test Result		
		Pass	Fail	N/A
15.207 Conducted emission AC power port	Site 1	<input checked="" type="checkbox"/>	<input type="checkbox"/>	<input type="checkbox"/>
§15.205(a), §15.209(a), §15.249(a), §15.249(c) & Field strength of emissions and Restricted bands	Site 1	<input checked="" type="checkbox"/>	<input type="checkbox"/>	<input type="checkbox"/>
§15.249(d) Out of band emissions	Site 1	<input checked="" type="checkbox"/>	<input type="checkbox"/>	<input type="checkbox"/>
FCC §15.215(c) 20dB bandwidth & 99% Occupied Bandwidth	Site 1	<input checked="" type="checkbox"/>	<input type="checkbox"/>	<input type="checkbox"/>
§15.203 Antenna requirement	See note 1	<input checked="" type="checkbox"/>	<input type="checkbox"/>	<input type="checkbox"/>

Remark 1: N/A- Not Applicable;

Note 1: The EUT used an integral PCB antenna, which gain is 2.0dBi. According to §15.203, it is considered sufficiently to comply with the provisions of this section.



## 6 General Remarks

### Remarks

This submittal(s) (test report) is intended for FCC ID: GV3-22SP001 complies with Section 15.207, 15.205, 15.209, 15.249 of the FCC Part 15, Subpart C Rules;

### SUMMARY:

All tests according to the regulations cited on page 5 were

n - Performed

o - **Not** Performed

The Equipment Under Test

n - **Fulfills** the general approval requirements.

o - **Does not** fulfill the general approval requirements.

Sample Received Date: 2022-04-01

Testing Start Date: 2022-04-01

Testing End Date: 2022-08-12

- TÜV SÜD Certification and Testing (China) Co., Ltd. Shenzhen Branch -

Reviewed by:

Prepared by:

Tested by:

John Zhi  
Project Manager

Mark Chen  
Project Engineer



Carry Cai  
Test Engineer

## 7 Test setups

### 7.1 AC Power Line Conducted Emission test setups

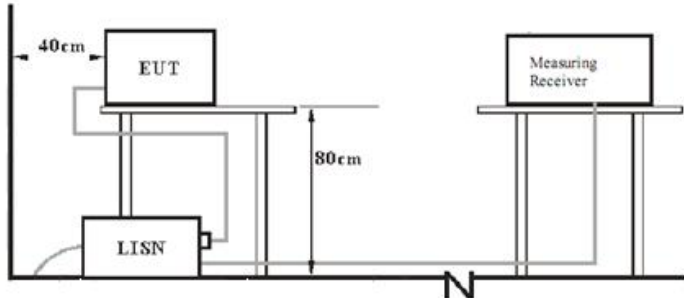

### 7.2 Radiated test setups

#### Below 1GHz

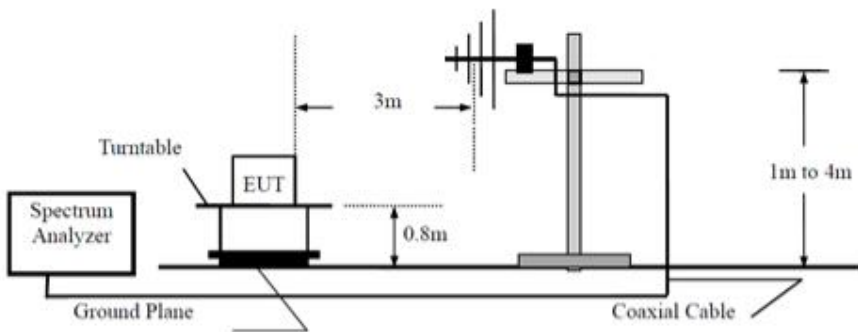

#### Above 1GHz

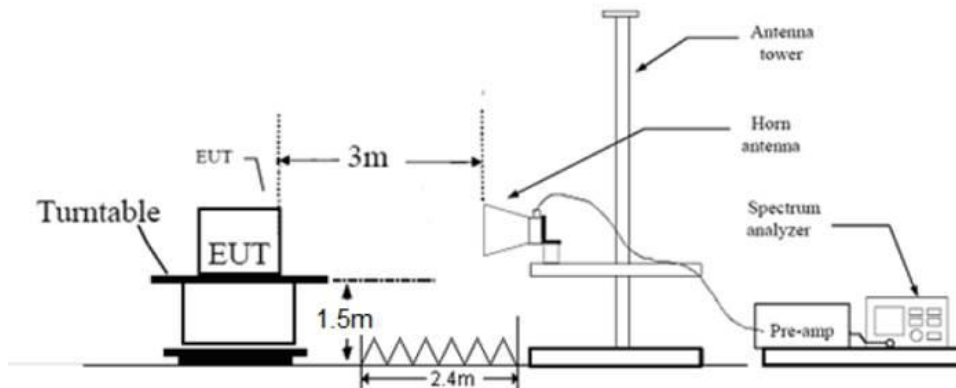





## 8 Technical Requirement

### 8.1 Conducted Emission

#### Test Method

1. The EUT was placed on a table, which is 0.8m above ground plane
2. The power line of the EUT is connected to the AC mains through a Artificial Mains Network (A.M.N.).
3. Maximum procedure was performed to ensure EUT compliance
4. A EMI test receiver is used to test the emissions from both sides of AC line

#### Limit

Frequency MHz	QP Limit dB $\mu$ V	AV Limit dB $\mu$ V
0.150-0.500	66-56*	56-46*
0.500-5	56	46
5-30	60	50

\*Decreasing linearly with logarithm of the frequency.



### Conducted Emission

Product Type : SensorPod  
 M/N : SensorPod  
 Operating Condition : Normal working with transmitting  
 Test specification : Live  
 Comment : AC 120V/60Hz

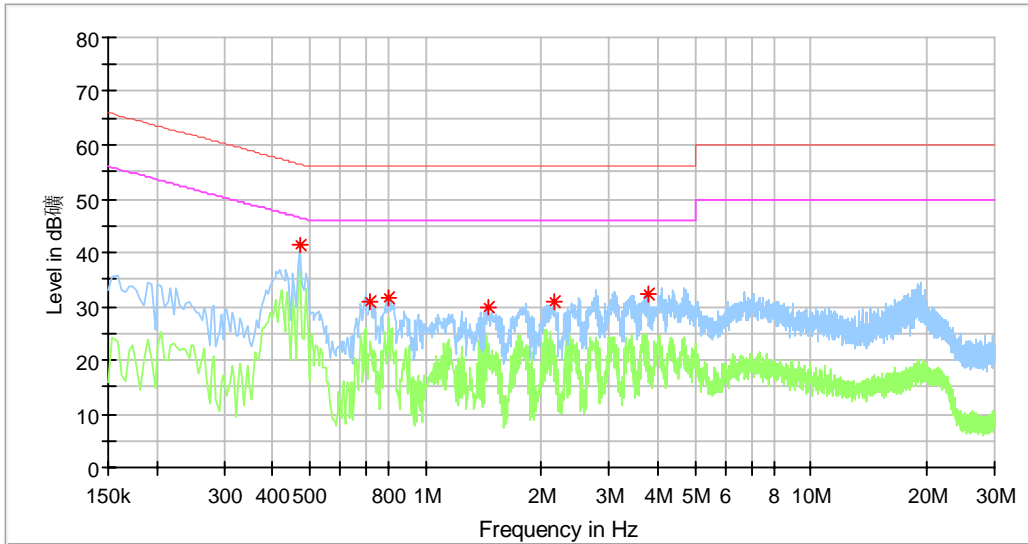

### Critical\_Freqs

Frequency (MHz)	MaxPeak (dBµV)	Average (dBµV)	Limit (dBµV)	Margin (dB)	Line	Corr. (dB/m)
0.470000	41.40	---	56.51	15.11	L1	9.65
0.714000	30.93	---	56.00	25.07	L1	9.65
0.798000	31.41	---	56.00	24.59	L1	9.66
1.450000	29.71	---	56.00	26.29	L1	9.67
2.166000	30.90	---	56.00	25.10	L1	9.69
3.766000	32.19	---	56.00	23.81	L1	9.76

Remark:

Level=Reading Level + Correction Factor

Correction Factor=Cable Loss + LISN Factor

(The Reading Level is recorded by software which is not shown in the sheet)



## Conducted Emission

Product Type : SensorPod  
 M/N : SensorPod  
 Operating Condition : Normal working with transmitting  
 Test specification : Neutral  
 Comment : AC 120V/60Hz

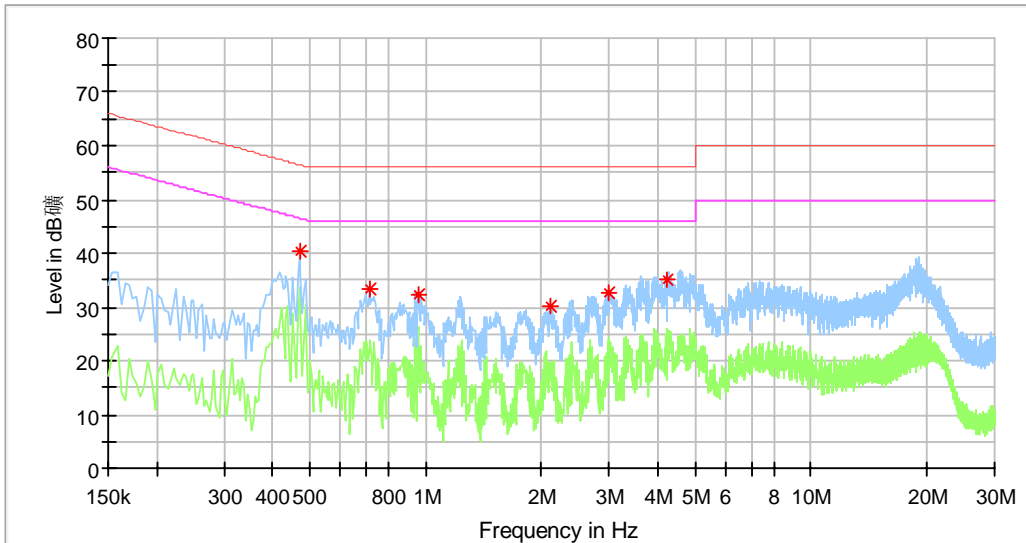

## Critical Freqs

Frequency (MHz)	MaxPeak (dBµV)	Average (dBµV)	Limit (dBµV)	Margin (dB)	Line	Corr. (dB/m)
0.470000	40.42	---	56.51	16.09	N	9.68
0.714000	33.27	---	56.00	22.73	N	9.68
0.958000	32.35	---	56.00	23.65	N	9.69
2.114000	30.10	---	56.00	25.90	N	9.74
2.978000	32.46	---	56.00	23.54	N	9.77
4.258000	34.93	---	56.00	21.07	N	9.83

### Remark:

Level=Reading Level + Correction Factor

Correction Factor=Cable Loss + LISN Factor

(The Reading Level is recorded by software which is not shown in the sheet)

## 8.2 Field strength of emissions and Restricted bands

### Test Method

- 1: The EUT was placed on a turn table which is 1.5m above ground plane for above 1GHz and 0.8m above ground for below 1GHz at 3-meter chamber room for test. The table was rotated 360 degrees to determine the position of the highest radiation.
- 2: The EUT was set 3 meters away from the interference – receiving antenna, which was mounted on the top of a variable – height antenna tower.
- 3: The height of antenna is varied from one meter to four meters above the ground to determine the maximum value of the field strength. Both horizontal and vertical polarizations of the antenna are set to make the measurement.
- 4: For each suspected emission, the EUT was arranged to its worst case and then the antenna was tuned to heights from 1 meter to 4 meters and the rotatable table was turned from 0 degrees to 360 degrees to find the maximum reading.
- 5: Use the following spectrum analyzer settings According to C63.10:

#### For Above 1GHz

Span = wide enough to capture the peak level of the in-band emission and all spurious  
RBW = 1MHz, VBW $\geq$ RBW for peak measurement and VBW = 10Hz for average measurement, Sweep = auto, Detector function = peak, Trace = max hold.

#### For Below 1GHz

Use the following spectrum analyzer settings:

Span = wide enough to capture the peak level of the in-band emission and all spurious  
RBW = 100 KHz, VBW $\geq$ RBW for peak measurement, Sweep = auto, Detector function = peak, Trace = max hold.

### Note:

- 1: The resolution bandwidth and video bandwidth of test receiver/spectrum analyzer is 120 KHz for Quasi-peak detection (QP) at frequency below 1GHz.
- 2: The resolution bandwidth of test receiver/spectrum analyzer is 1MHz and the video bandwidth is 3MHz for peak detection (PK) at frequency above 1GHz.
- 3: The resolution bandwidth of test receiver/spectrum analyzer is 1MHz and the video bandwidth is 3MHz for RMS Average ((duty cycle < 98%) for Average detection (AV) at frequency above 1GHz, then the measurement results was added to a correction factor (20log (1/duty cycle)).
- 4: The resolution bandwidth of test receiver/spectrum analyzer is 1MHz and the video bandwidth is 10Hz (duty cycle > 98%) for Average detection (AV) at frequency above 1GHz.



**Field strength of emissions and Restricted bands**

**Limits**

According to §15.249 (a) the field strength of emissions from intentional radiators operated within these frequency bands shall comply with the following:

Fundamental frequency	Field strength of fundamental (millivolts/meter)	Field strength of harmonics (microvolts/meter)
902–928 MHz	50	500
2400–2483.5 MHz	50	500
5725–5875 MHz	50	500
24.0–24.25 GHz	250	2500

According to §15.249 (c), Field strength limits are specified at a distance of 3 meters. According to §15.249 (d), Emissions radiated outside of the specified frequency bands, except for harmonics, shall be attenuated by at least 50 dB below the level of the fundamental or to the general radiated emission limits in §15.209, whichever is the lesser attenuation.

Frequency MHz	Field Strength $\mu\text{V/m}$	Field Strength $\text{dB}\mu\text{V/m}$	Detector
30-88	100	40	QP
88-216	150	43.5	QP
216-960	200	46	QP
960-1000	500	54	QP
Above 1000	500	54	AV
Above 1000	5000	74	PK



**Field strength of emissions and Restricted bands**

According to C63.10, if the peak (or quasi-peak) measured value complies with the average limit, it is unnecessary to perform an average measurement, so AV emission value did not show in below table if the peak value complies with average limit.

**Fundamental test result as below:**

2462MHz Test Result

Radiated Emission									
Value	Emissions Frequency MHz	E-Field Polarity	PK Emission dBµV/m	Corr.	Average Factor dB	AV Emission dBµV/m	Limit dBµV/m	Margin	Emission Type
PK	2462	H	80.50	-2.71	0.00	/	114.00	33.5	Fundamental
AV	2462	H	80.50	/	-7.16	73.34	94.00	20.66	Fundamental
PK	2462	V	80.90	-2.71	0.00	/	114.00	33.1	Fundamental
AV	2462	V	80.90	/	-7.16	73.74	94.00	20.26	Fundamental

**Transmitting spurious emission test result as below:**

2462MHz Test Result

Radiated Emission									
Value	Emissions Frequency MHz	E-Field Polarity	PK Emission dBµV/m	Corr.	Average Factor dB	AV Emission dBµV/m	Limit dBµV/m	Margin	Emission Type
Below 1GHz									
PK	923.37	H	34.21	32.96	0.00	/	46	11.79	Spurious
AV	923.37	H	34.21	/	-7.16	27.05	46	18.95	Spurious
PK	160.41	V	33.80	16.13	0.00	/	43.5	9.7	Spurious
AV	160.41	V	33.80	/	-7.16	24.64	43.5	18.86	Spurious
Above 1GHz									
PK	4792.5	H	50.27	4.36	0.00	/	74.00	23.73	Spurious
AV	4792.5	H	50.27	/	-7.16	43.11	54.00	10.89	Spurious
PK	4698	V	49.70	4.30	0.00	/	74.00	24.30	Spurious
AV	4698	V	49.70	/	-7.16	42.54	54.00	11.46	Spurious



Duty cycle= $0.5362 \times 16 / 19.565 \text{ms} = 0.4385$   
 Peak to average duty cycle correction factor =  $20 \log(\text{duty cycle}) = -7.16$

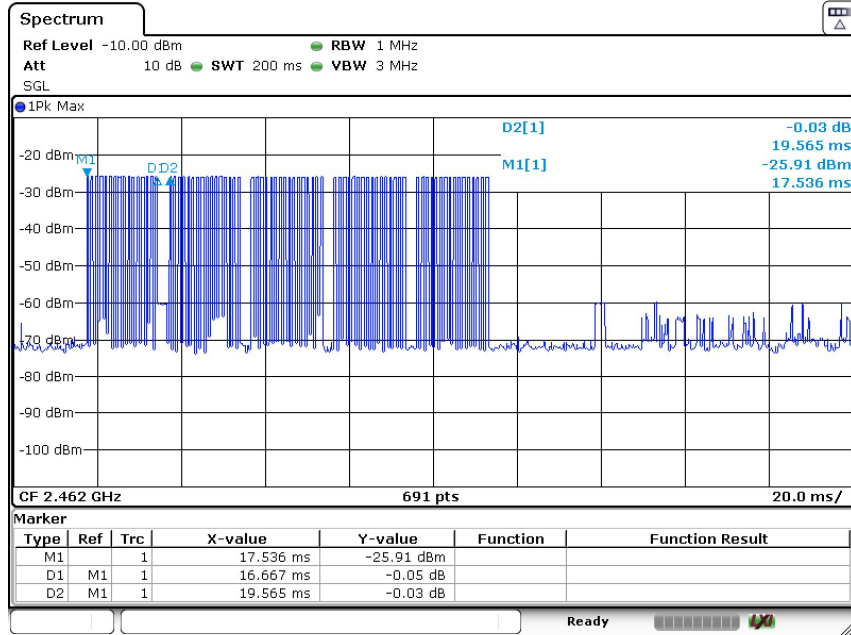

Date: 29 JUL 2022 17:14:12

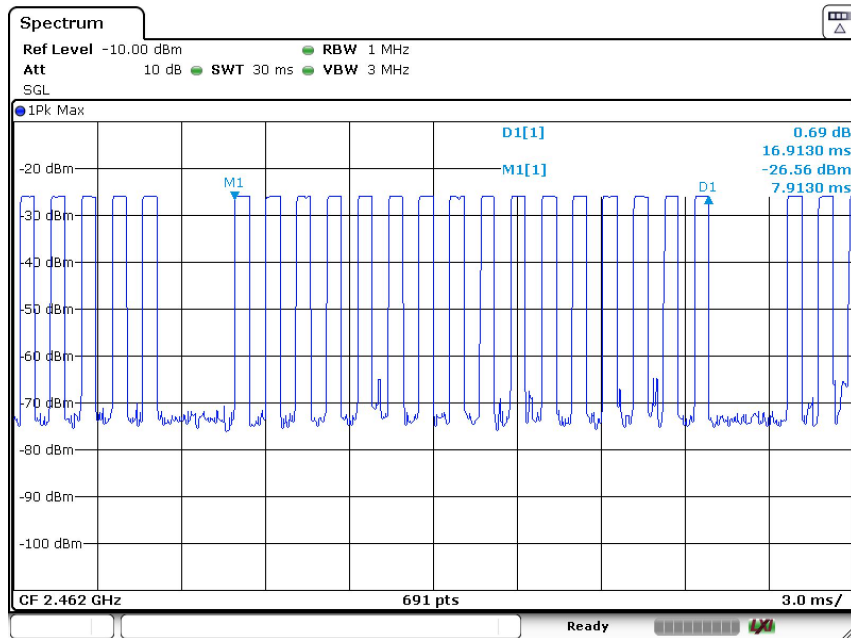

Date: 29 JUL 2022 17:16:47

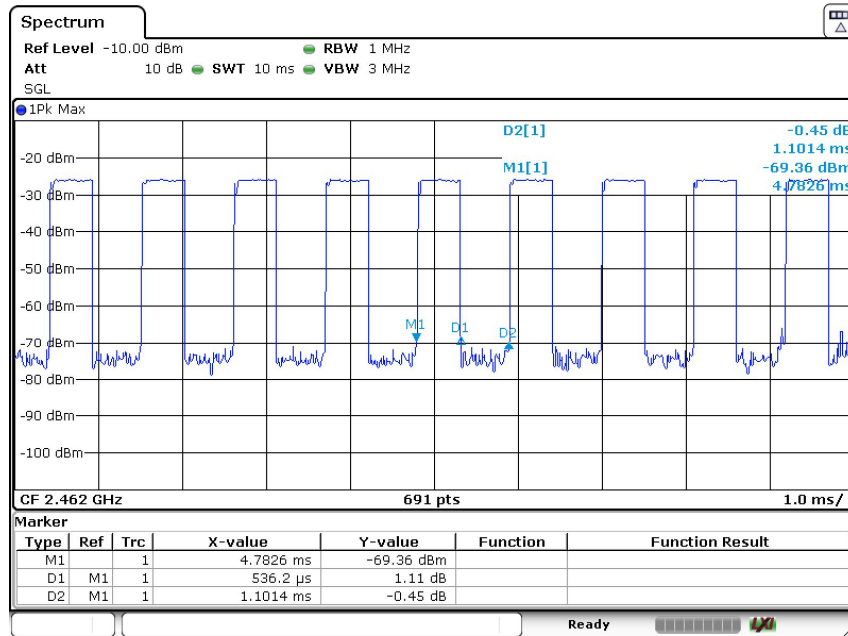

Date: 29.JUL.2022 17:16:06

Remark:

- (1) Data of measurement within this frequency range shown "--" in the table above means the reading of emissions are the noise floor or attenuated more than 10dB below the permissible limits or the field strength is too small to be measured.
- (2) Corrected Amplitude= Read level + Corrector factor  
 Above 1GHz: Corrector factor = Antenna Factor + Cable Loss- Pre-amplifier  
 Below 1GHz: Corrector factor = Antenna Factor + Cable Loss  
 (The Reading Level is recorded by software which is not shown in the sheet)
- (3) AV Emission = Average Reading Level + Correction Factor (for duty cycle ≤ 98%)





## 8.3 Out of Band Emissions

### Test Method

- 1 Use the following spectrum analyzer settings:  
Span = wide enough to capture the peak level of the in-band emission and all spurious  
RBW = 100 kHz, VBW $\geq$ RBW, Sweep = auto, Detector function = peak, Trace = max  
hold.
- 2 Allow the trace to stabilize, use the peak and delta measurement to record the result.
- 3 The level displayed must comply with the limit specified in this Section.

### Limits

According to §15.249(d) Emissions radiated outside of the specified frequency bands, except for harmonics, shall be attenuated by at least 50 dB below the level of the fundamental or to the general radiated emission limits in §15.209, whichever is the lesser attenuation.



## Out of Band Emissions

2462MHz

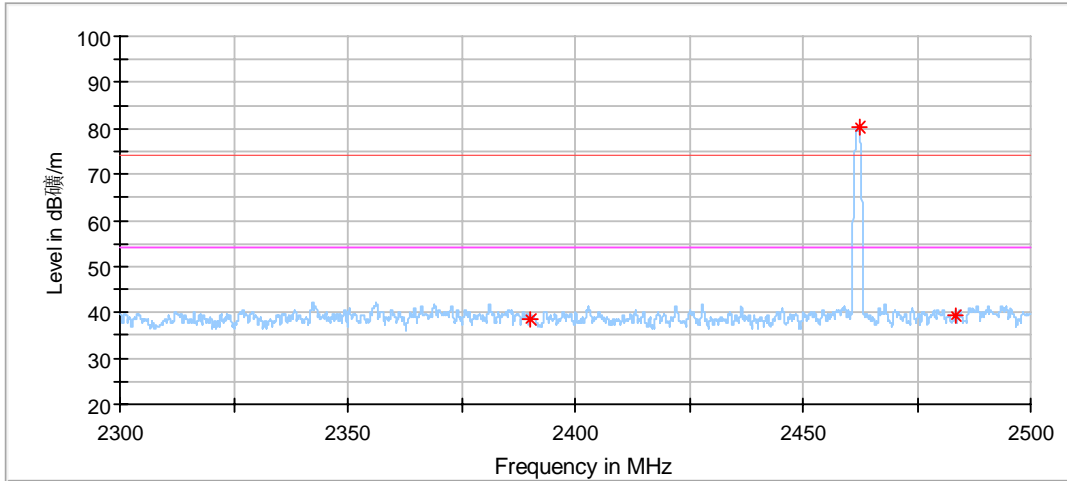

### Critical Freqs

Frequency (MHz)	MaxPeak (dBµV/m)	Limit (dBµV/m)	Margin (dB)	Height (cm)	Pol	Azimuth (deg)	Corr. (dB/m)
2390.000000	38.33	74.00	35.67	150.0	H	322.0	-2.93
2462.220000	80.50	74.00	-6.50	150.0	H	356.0	-2.71
2483.500000	39.40	74.00	34.60	150.0	H	231.0	-2.60

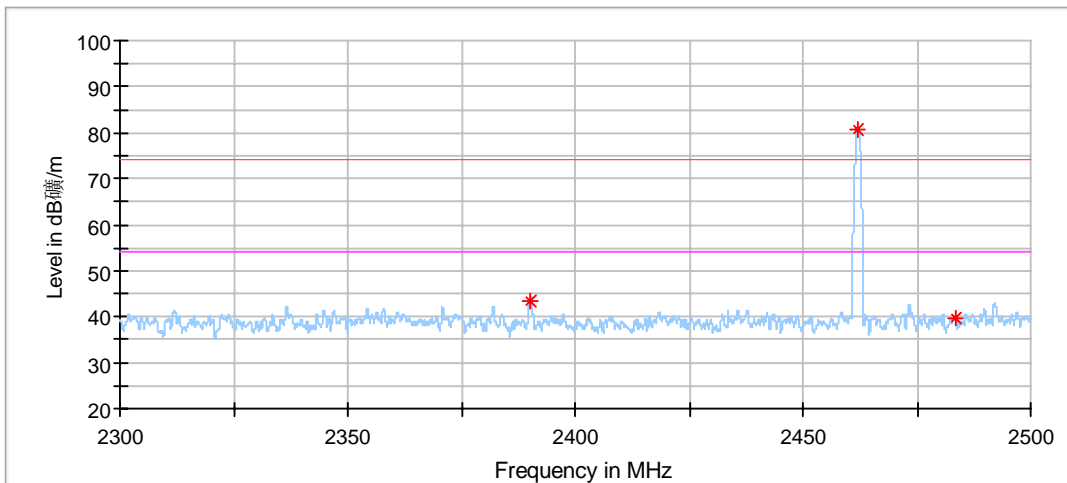

### Critical Freqs

Frequency (MHz)	MaxPeak (dBµV/m)	Limit (dBµV/m)	Margin (dB)	Height (cm)	Pol	Azimuth (deg)	Corr. (dB/m)
2390.000000	43.57	74.00	30.43	150.0	V	69.0	-2.93
2462.000000	80.90	74.00	-6.90	150.0	V	300.0	-2.71
2483.500000	39.50	74.00	34.50	150.0	V	354.0	-2.60



## 8.4 20dB Bandwidth & 99% Occupied Bandwidth

### Test Method

1. Check the calibration of the measuring instrument using either an internal calibrator or a known signal from an external generator.
2. Position the EUT without connection to spectrum analyser. Turn on the EUT and connect it to measurement instrument. Then set it to any one convenient frequency within its operating range. Set a reference level on the measuring instrument equal to the highest peak value.
3. Measure the frequency difference of two frequencies that were attenuated 20dB from the reference level. Record the frequency difference as the emission bandwidth.

### Limits:

According to 15.215 (c) Intentional radiators operating under the alternative provisions to the general emission limits, as contained in §§ 15.217 through 15.257 and in Subpart E of this part, must be designed to ensure that the 20 dB bandwidth of the emission, or whatever bandwidth may otherwise be specified in the specific rule section under which the equipment operates, is contained within the frequency band designated in the rule section under which the equipment is operated. The requirement to contain the designated bandwidth of the emission within the specified frequency band includes the effects from frequency sweeping, frequency hopping and other modulation techniques that may be employed as well as the frequency stability of the transmitter over expected variations in temperature and supply voltage. If a frequency stability is not specified in the regulations, it is recommended that the fundamental emission be kept within at least the central 80% of the permitted band in order to minimize the possibility of out-of-band operation.



### 20dB Bandwidth & 99% Occupied Bandwidth

Frequency	20dB Bandwidth	99% Bandwidth	Limit
MHz	MHz	MHz	MHz
2462	2.072	2.084	--

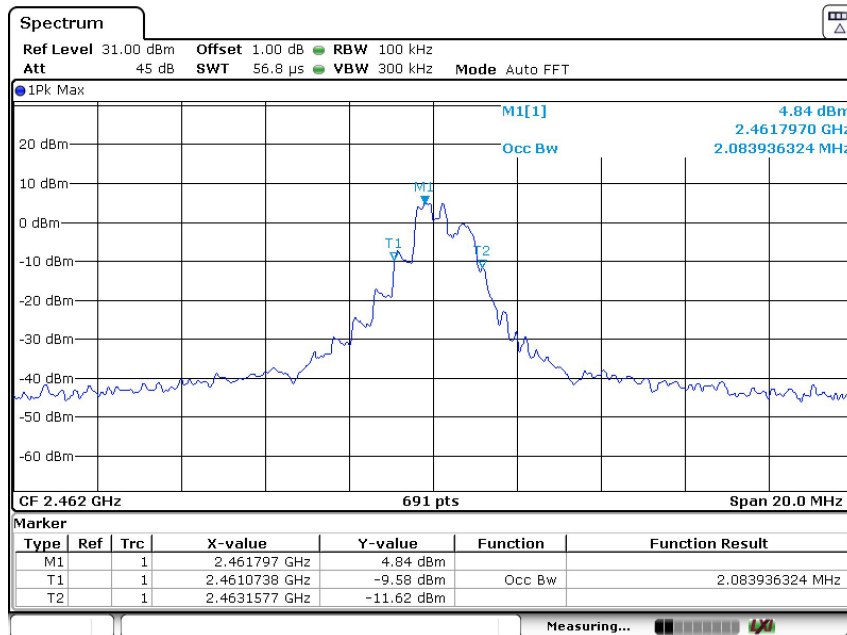
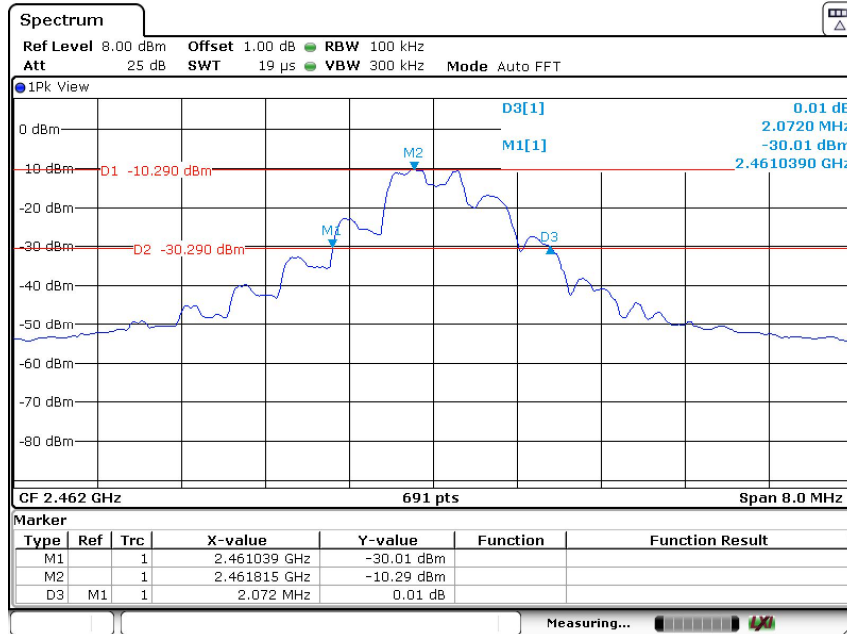

2462MHz



## 9 Test equipment lists

### Conducted Emission 1# Test

Description	Manufacturer	Model no.	Equipment ID	Serial no.	cal interval (year)	cal. due date
EMI Test Receiver	Rohde & Schwarz	ESR 3	68-4-74-14-001	101782	1	2023-5-27
LISN	Rohde & Schwarz	ENV4200	68-4-87-14-001	100249	1	2023-5-27
LISN	Rohde & Schwarz	ENV432	68-4-87-16-001	101318	1	2023-5-27
LISN	Rohde & Schwarz	ENV216	68-4-87-14-002	100326	1	2023-5-27
ISN	Rohde & Schwarz	ENY81	68-4-87-14-003	100177	1	2023-5-27
ISN	Rohde & Schwarz	ENY81-CA6	68-4-87-14-004	101664	1	2023-5-27
High Voltage Probe	Schwarzbeck	TK9420(VT9420)	68-4-27-14-001	9420-584	1	2023-5-27
RF Current Probe	Rohde & Schwarz	EZ-17	68-4-27-14-002	100816	1	2023-5-31
Attenuator	Shanghai Huaxiang	TS2-26-3	68-4-81-16-003	080928189	1	2023-5-27
Test software	Rohde & Schwarz	EMC32	68-4-90-14-003-A10	Version9.15.00	N/A	N/A
Shielding Room	TDK	CSR #1	68-4-90-19-004	----	3	2022-11-07

### Radiated Emission 2# Test

Description	Manufacturer	Model no.	Equipment ID	Serial no.	cal interval (year)	cal. due date
EMI Test Receiver	Rohde & Schwarz	ESR 26	68-4-74-14-002	101269	1	2023-5-28
Trilog Super Broadband Test Antenna	Schwarzbeck	VULB 9162	68-4-80-19-003	284	1	2023-1-17
Wave Guide Antenna	ETS	3117	68-4-80-19-001	00218954	1	2023-5-9
Pre-amplifier	Rohde & Schwarz	SCU 18F	68-4-29-19-001	100745	1	2023-5-28
Pre-amplifier	Rohde & Schwarz	SCU 18F	68-4-29-19-002	100746	1	2023-5-28
Sideband Horn Antenna	Q-PAR	QWH-SL-18-40-K-SG	68-4-80-14-008	12827	1	2023-7-12
Pre-amplifier	Rohde & Schwarz	SCU 40A	68-4-29-14-002	100432	1	2023-7-27
Attenuator	Mini-circuits	UNAT-6+	68-4-81-21-002	15542	1	2023-5-27
3m Semi-anechoic chamber	TDK	SAC-3 #2	68-4-90-19-006	----	2	2023-5-28
Test software	Rohde & Schwarz	EMC32	68-4-90-19-006-A01	Version10.35.02	N/A	N/A



## 10 System Measurement Uncertainty

For a 95% confidence level, the measurement expanded uncertainties for defined systems, in accordance with the recommendations of ISO 17025 were:

System Measurement Uncertainty	
Test Items	Extended Uncertainty
Uncertainty for Conducted Emission 150kHz-30MHz (for test using AMN ENV432 or ENV4200)	3.15dB
Uncertainty for Radiated Emission in 3m chamber 30MHz-1000MHz	Horizontal: 4.59dB; Vertical: 4.75dB;
Uncertainty for Radiated Spurious Emission 1000MHz-18000MHz	Horizontal: 5.08dB; Vertical: 5.09dB;
Uncertainty for Radiated Spurious Emission 18000MHz-40000MHz	Horizontal: 4.51dB; Vertical: 4.50dB;