

TEST REPORT CERTIFICATION

Applicant : Matsushita Electric Industrial Co., Ltd.
 Manufacturer : Matsushita Electric Industrial Co., Ltd.
 FCC ID : ACJ93312136
 EUT Description : 17" Color CRT Display Monitor
 (A) MODEL NO. : (1)TX-D7S36NM (2)TX-D7S36
 (3)TX-D7S36***** (4)VCDTS21406-2*
 (B) SERIAL NO. : FX8210010
 (C) POWER SUPPLY : AC 120V/60Hz

Measurement Procedure Used:

FCC RULES AND REGULATIONS PART 15 SUBPART B CLASS B OCTOBER 1996
 AND FCC / ANSI C63.4-1992

The device described above was tested by TAIWAN TOKIN EMC ENG. CORP. to determine the maximum emission levels emanating from the device. The maximum emission levels were compared to the FCC Part 15B Class B limits both radiated and conducted emissions.

The measurement results were contained in this test report and TAIWAN TOKIN EMC ENG. CORP. was assumed full responsibility for the accuracy and completeness of these measurements. Also, this report showed that the EUT to be technically compliant with the FCC official limits. TAIWAN TOKIN EMC ENG. CORP. recommend that this data was submitted for FCC certification purposes if a 6dB margin below FCC limits was obtained. This report applied to above tested sample only. This report shall not be reproduced in part without written approval of Taiwan Tokin EMC Eng. corp.

Date of Test : Apr. 01 / 02, 1998

Prepared by :

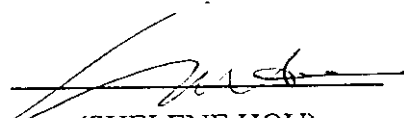
 (SHELENE HOU)

Test Engineer :

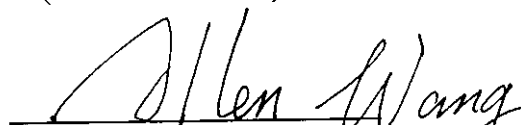
 (ALLEN WANG)

Approve & Authorized Signer :

 (JACKIE DENG)

1. GENERAL INFORMATION

1.1. Description of Device (EUT)

Description : 17" Color CRT Display Monitor

Model Number : (1)TX-D7S36NM (2)TX-D7S36
(3)TX-D7S36***** (4)VCDTS21406-2*

The model TX-D7S36NM is No Brand; the TX-D7S36 is for Panasonic Brand; the TX-D7S36***** means the future OEM brand model and "*" may be followed by some suffix numbers, alphabets, blanks and hyphens. Differences between TX-D7S36NM and TX-D7S36***** are only cosmetic change and power supply cord, the VCDTS21406-2* is for ViewSonic brand, and the "*" means one suffix such as 1 to 9 or alphabet A to Z will be added..

Serial Number : FX8210010

Applicant : Matsushita Electric Industrial Co., Ltd.
6-4-1, Tsujidomotomachi, Fujisai,
Kanagai, 251, Japan

Manufacturer : Matsushita Electric Industrial Co., Ltd.
6-4-1, Tsujidomotomachi, Fujisai,
Kanagai, 251, Japan

CRT : Panasonic, M/N M41LJV000X 7D G

Data Cable # 1 (D-Sub) : Shielded, Detachable, 1.5m
Bonded two ferrite cores

Data Cable # 2 (D-Sub) : Shielded, Detachable, 1.8m
Bonded two ferrite cores

Data Cable # 3 (D-Sub) : Shielded, Detachable, 3m
Bonded two ferrite cores

Power Cord : Unshielded, Detachable, 1.8m

Date of Test : Apr. 01 / 02 , 1998

1.2. Tested System Details

1.2.1. PERSONAL COMPUTER

Model Number	:	Vectra VL5/166 Series 5DT
Serial Number	:	SG71501857
FCC ID	:	By DoC
Manufacturer	:	Hewlett Packard
VGA Card	:	Dataexpert Corp
		M/N DSV3365E, FCC ID LUT-DSV3365
Power Cord	:	Nonshielded, Detachable, 1.8m

1.2.2. KEYBOARD

Model Number	:	SK-1000REW
Serial Number	:	M970440089
FCC ID	:	GYUR36SK
Manufacturer	:	Hewlett Packard
Data Cable	:	Shielded, Undetachable, 1.9m

1.2.3. PRINTER

Model Number	:	2225C
Serial Number	:	2526S40437
FCC ID	:	BS46XU2225C
Manufacturer	:	Hewlett Packard
Power Cord	:	Nonshielded, Undetachable, 1.8m
Data Cable	:	Shielded, Detachable, 1.2m

1.2.4. MODEM # 1

Model Number	:	1414
Serial Number	:	950110300
FCC ID	:	IFAXDM1414
Manufacturer	:	Aceex
Data Cable	:	Shielded, Detachable, 1.2m
Power Adapter	:	Amigo, Model AM-91000A
		Nonshielded, Undetachable, 1.8m

1.2.5. MODEM # 2

Model Number : 1414
 Serial Number : 970024518
 FCC ID : IFAXDM1414
 Manufacturer : Aceex
 Data Cable : Shielded, Detachable, 1.2m
 Power Adapter : Amigo, Model AM-91000A
 Nonshielded, Undetachable, 1.8m

1.2.6. MOUSE

Model Number : C3751B
 Serial Number : LZA71180116
 FCC ID : DZL211029
 Manufacturer : Hewlett Packard
 Data Cable : Shielded, Undetachable, 1.8m

1.2.7. USB GAMEPAD # 1

Model Number : INT-002
 Serial Number : N/A
 FCC ID : CWTEAK032
 Manufacturer : Alps
 Data Cable : Shielded, Undetachable, 1.6m
 Bonded a ferrite core

1.2.8. USB GAMEPAD # 2

Model Number : INT-003
 Serial Number : N/A
 FCC ID : CWTEAK032
 Manufacturer : Alps
 Data Cable : Shielded, Undetachable, 2.3m
 Bonded a ferrite core

1.3. Description of Test Facility

Site Description : Jul. 15, 1996 Re-file on
 (No. 2 Open Site) Federal Communication Commission
 FCC Engineering Laboratory
 7435 Oakland Mills Road
 Columbia, MD 21046, U.S.A.

Name of Firm : Taiwan Tokin EMC Eng. Corp.

Site Location : No. 53-11, Tin-Fu Tsun, Lin-Kou,
 Taipei Hsien, Taiwan, R.O.C.

NVLAP lab. Code : 200077-0

2. POWERLINE CONDUCTED TEST

2.1. Test Equipment

The following test equipments were used during the power line conducted tests :

Item	Type	Manufacturer	Model No.	Serial No.	Last Cal.	Cal. Interval
1.	Test Receiver	Rohde & Schwarz	ESH3	893044/015	Aug.01, 97'	1 Year
2.	L.I.S.N. # 1	Kyoritsu	KMW-407	8-855-9	May.01, 97'	1 Year
3.	L.I.S.N. # 2	Kyoritsu	KMW-407	8-881-13	May.01, 97'	1 Year

2.2. Block Diagram of Test Setup

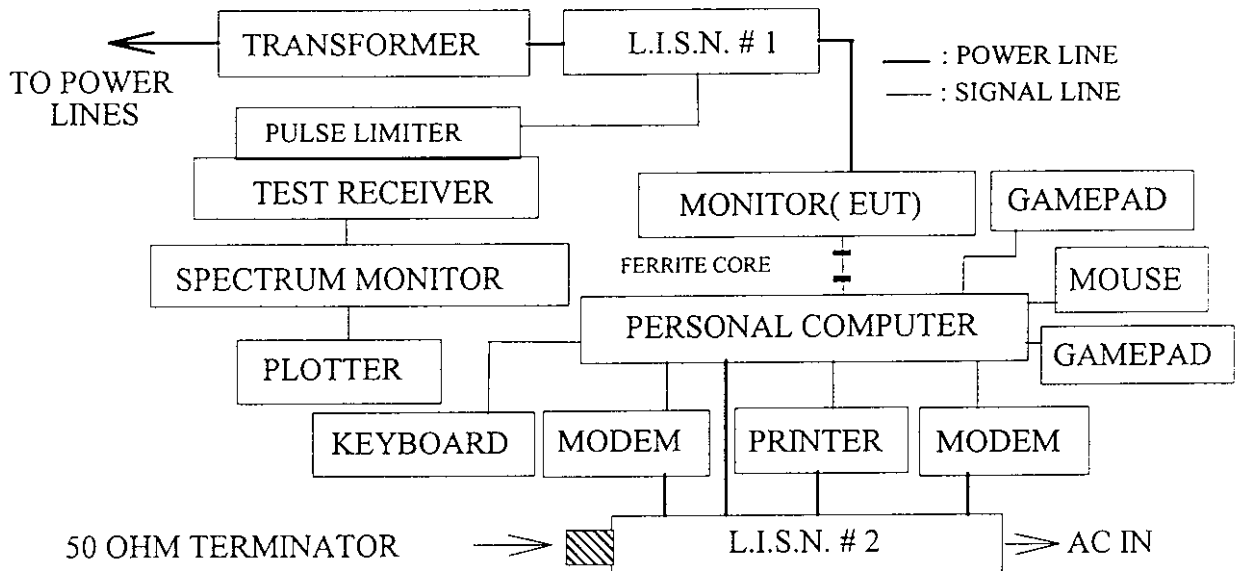

2.3. Conducted Powerline Emission Limit (CLASS B)

Frequency	Maximum RF Line Voltage	
	uV	dBuV
0.45MHz ~ 30Mhz	250	48

REMARKS : RF LINE VOLTAGE (dBuV) = 20 log RF LINE VOLTAGE (uV)

2.4. EUT Configuration on Measurement

The following equipments were installed on RF LINE VOLTAGE measurement to meet the Commission requirement and operating in a manner which tend to maximize its emission characteristics in a normal application.

2.4.1. 17" Color CRT Display Monitor (EUT)

Model Number	:	(1)TX-D7S36NM (2)TX-D7S36 (3)TX-D7S36***** (4)VCDTS21406-2*
Serial Number	:	FX8210010
Manufacturer	:	Matsushita Electric Industrial Co., Ltd.
CRT	:	Panasonic, M/N M41LJV000X 7D G
Data Cable # 1 (D-Sub)	:	Shielded, Detachable, 1.5m Bonded two ferrite cores
Data Cable # 2 (D-Sub)	:	Shielded, Detachable, 1.8m Bonded two ferrite cores
Data Cable # 3 (D-Sub)	:	Shielded, Detachable, 3m Bonded two ferrite cores
Power Cord	:	Unshielded, Detachable, 1.8m

2.4.2. Support Equipments : As in 1.2 Test System Details

2.5. Operating Condition of EUT

2.5.1. Setup the EUT and simulator as shown on 2.2.

2.5.2. Turn on the power of all equipments.

2.5.3. Personal Computer read data from disk.

2.5.4. Personal Computer sent "H" character to monitor (EUT) and the screen displayed and full with "H" pattern.

2.5.5. The other peripheral devices were drone and operated in turn during all testing.

2.6. Test Procedure

The EUT was connected to the power mains through a line impedance stabilization network (L.I.S.N.# 1). The other peripheral devices power cord connected to the power mains through a line impedance stabilization network (L.I.S.N. # 2). This provided a 50 ohm coupling impedance for the measuring equipment. (Please refer to the block diagram of the test setup and photographs.)

Both sides of A.C. line were checked for maximum conducted interference. In order to find the maximum emission, the relative positions of equipments and all of the interface cables were changed according to FCC ANSI C63.4-1992 on conducted measurement.

The bandwidth of the field strength meter (R & S Test Receiver ESH3) was set at 10KHz.

The frequency range from 450KHz to 30MHz was checked.

Two kinds of horizontal working frequency with three kinds of data cables were investigated during pre-scanning and reported the worst test mode (64KHz with 3m D-Sub Data Cable) in section 2.7., the others test data were attached within Appendix I. The detail of test modes are as follows :

Two kinds of display frequency :

	VGA480 (Hf : 31.5KHz)	1280 x 1024 (Hf : 64KHz)
(a) Dot Clock Frequency	25.17 MHz	108 MHz
(b) Vertical Frequency	60 Hz	60 Hz
(c) Horizontal Frequency	31.5 KHz	64 KHz

Three kinds of data cable :

- (1) 1.5m D-Sub data cable with two ferrite cores
- (2) 1.8m D-Sub data cable with two ferrite cores
- (3) 3.0m D-Sub data cable with two ferrite cores

2.7. Line Conducted RF Voltage Measurement Results

The frequency range 450KHz to 30 MHz was investigated.
 All emissions not reported below were too low against the prescribed limits.

Date of Test : Apr. 02, 1998 Temperature : 20 °C

EUT : 17" Color CRT Display Monitor Humidity : 65 %

Test Mode : 64KHz/1280*1024 With 3m D-Sub Data Cable

Frequency (MHz)	Factor dB	Measurement (dBuV)		Reading (dBuV)		Limits (dBuV)	Margin (dBuV)	
		VA	VB	VA	VB		VA	VB
0.4500	0.2	40.5	39.8	40.7	40.0	48.0	7.3	8.0
0.5131	0.2	35.8	*	36.0	*	48.0	12.0	*
0.5773	0.2	*	33.2	*	33.4	48.0	*	14.6
0.7056	0.2	29.8	30.4	30.0	30.4	48.0	18.0	17.6
1.2830	0.2	26.8	25.6	27.0	25.8	48.0	21.0	22.2
13.5369	0.6	33.6	33.2	34.2	33.8	48.0	13.8	14.2
27.0740	1.0	39.1	39.1	40.1	40.1	48.0	7.9	7.9

- Remark :
1. All reading were Quasi-Peak values.
 2. Factor = Insertion Loss + Cable Loss
 3. The worst emission was detected at 0.4500MHz with corrected signal level of 40.7dBuV (limit was 48dBuV) when the VA side of the EUT was connected to L.I.S.N.

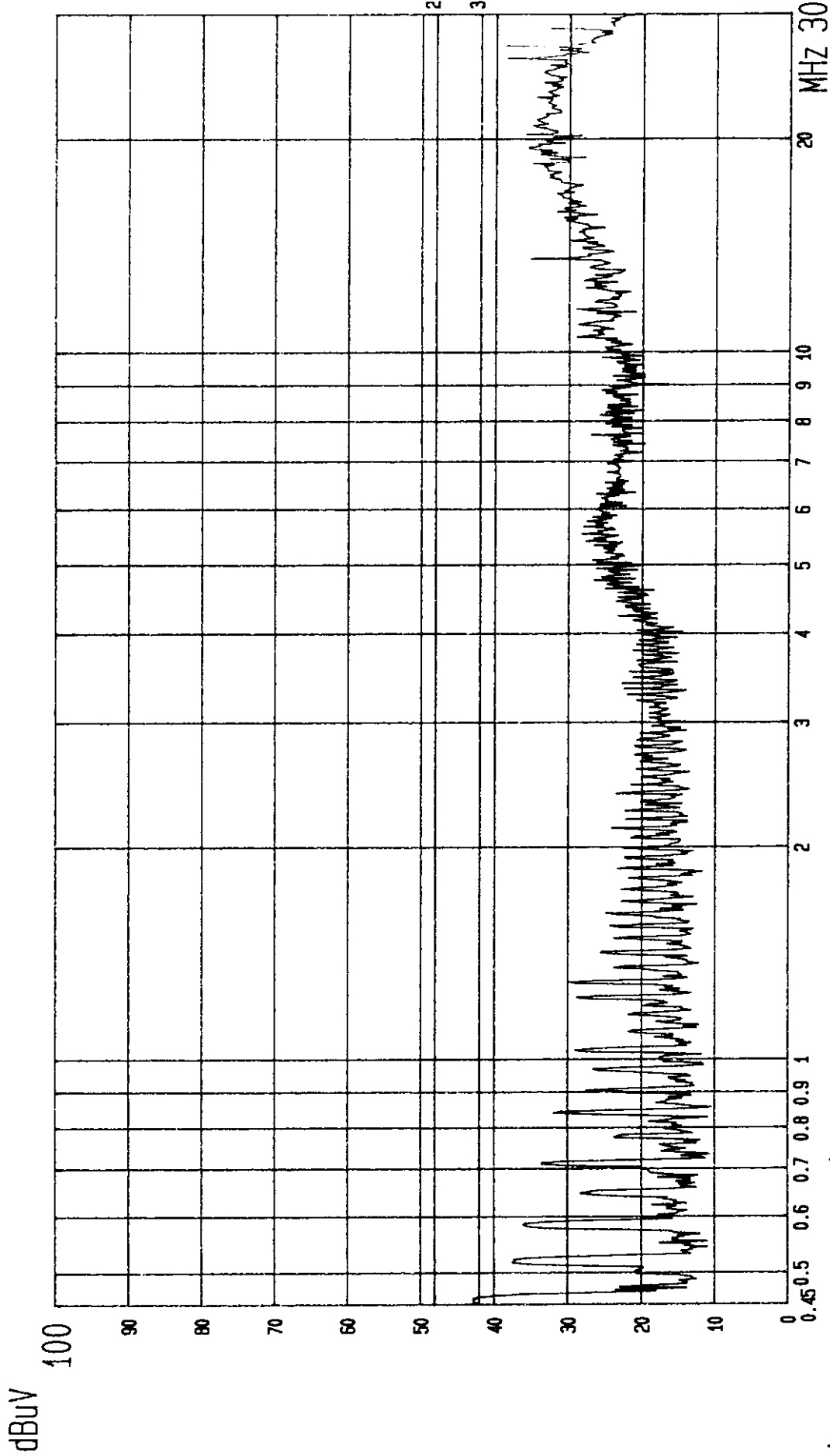

----- Date 02.APR.'98 Time 10:29:16

MATSUSHITA

EUT: MONITOR

M/N: TX-D7S36NM; VCDTS21406-2*

PAGE: 008.

LINE: VA.

MEMO: 64KHZ (1280X1024; 60HZ); 3.0m D-SUB

(PEAK VALUE)

TTEMC.

dBuV

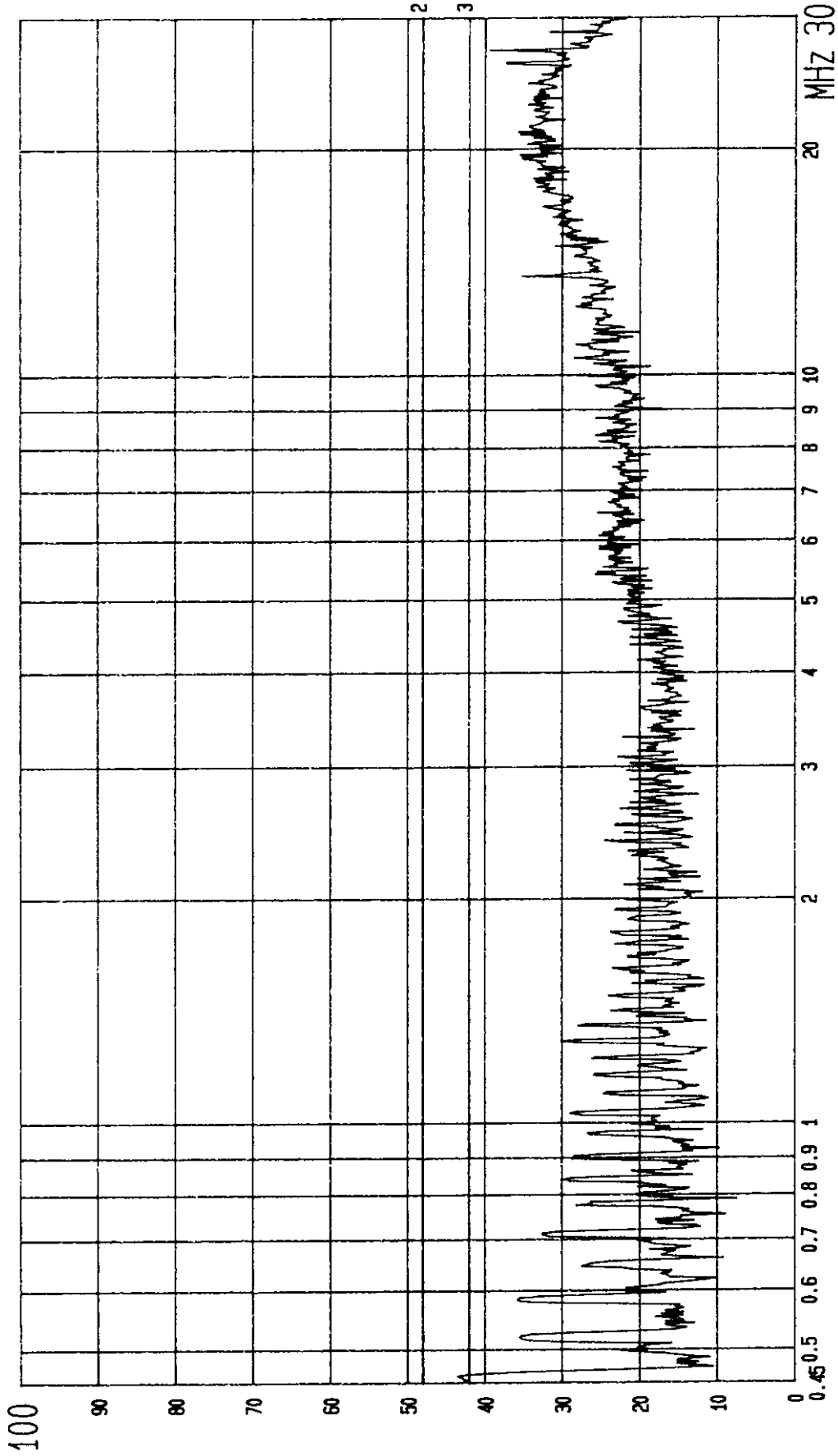

--- Date 02.APR.'98 Time 10:26:52

MATSUSHITA EUT: MONITOR

LINE: VB.

M/N: TX-D7S36NM; VCDTS21406-2*
(PEAK VALUE)

MEMO: 64KHZ (1280X1024; 60HZ); 3.0m D-SUB

PAGE: 007.
ITEMC.

3. RADIATED EMISSION TEST

3.1. Test Equipment

The following test equipments are used during the radiated emission tests :

3.1.1. For Anechoic Chamber :

Item	Type	Manufacturer	Model No.	Serial No.	Last Cal.	Cal. Interval
1.	Spectrum Analyzer	HP	8593A	3212A01727	Aug.02, 97'	1 Year
2.	Pre-Amplifier	HP	8447D	2944A06305	Jun.07, 97'	1 Year
3.	Broadband Antenna	Schwarzbeck	BBA 9106	A3L	Dec.24, 97'	1 Year
4.	Broadband Antenna	Schwarzbeck	UHALP 9107	A3H	Dec.24, 97'	1 Year

3.1.2. For No. 2 Open Site :

Item	Type	Manufacturer	Model No.	Serial No.	Last Cal.	Cal. Interval
1.	Test Receiver	Rohde&Schwarz	ESVP	893202/001	Aug.04, 97'	1 Year
2.	Broadband Antenna	Chase	VBA6106A	1240	Jan.14, 98'	1 Year
3.	Broadband Antenna	Schwarzbeck	UHALP 9108-A	0139	Jan.14, 98'	1 Year

3.2. Block Diagram of Test Setup

3.2.1. Block Diagram of connection between EUT and simulators

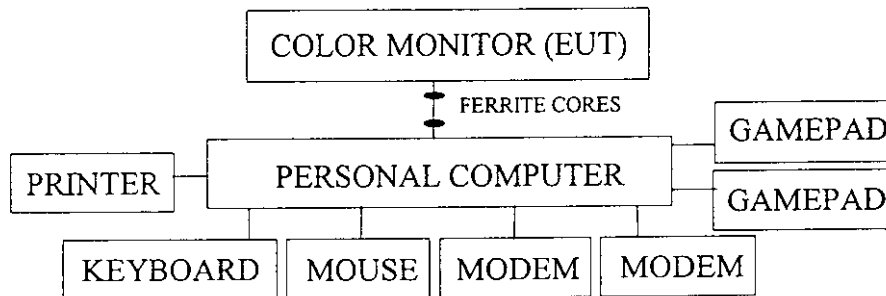

3.2.2. Open Field Test Site Setup Diagram

ANTENNA TOWER

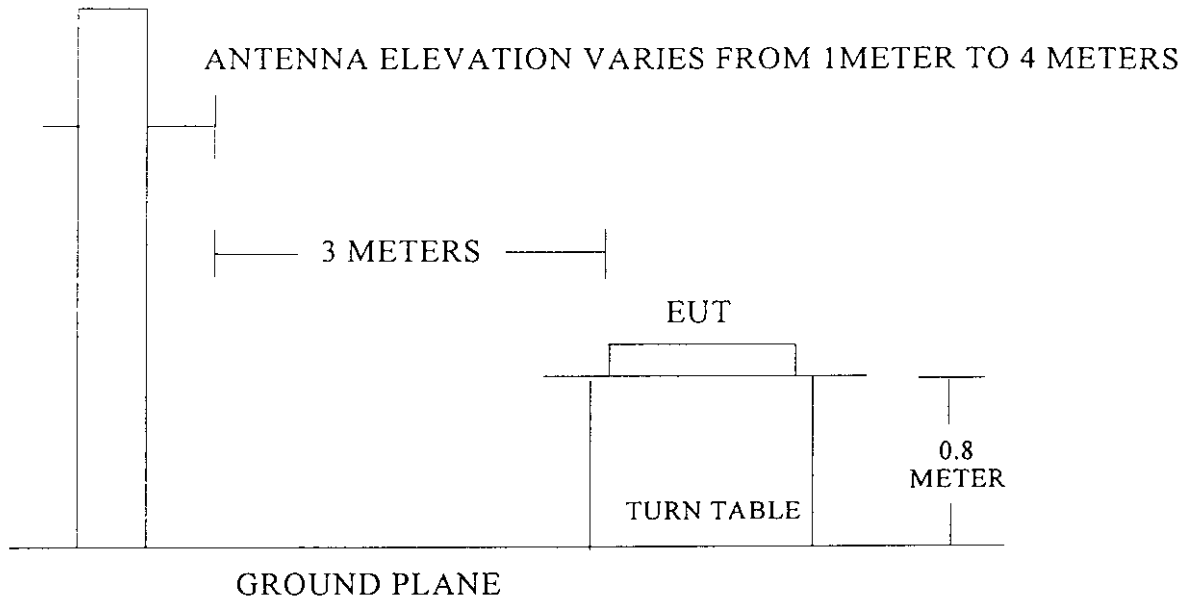

3.3. Radiation Limit (CLASS B)

FREQUENCY MHz	DISTANCE Meters	FIELD STRENGTHS LIMITS	
		uV/M	dBuV/M
30 ~ 88	3	100	40.0
88 ~ 216	3	150	43.5
216 ~ 960	3	200	46.0
960 ~ 1000	3	500	54.0

- Remark :
- (1) Emission level (dBuV/M) = 20 log Emission level (uV/M)
 - (2) The tighter limit applies at the edge between two frequency bands.
 - (3) Distance refers to the distance in meters between the measuring instrument antenna and the closed point of any part of the device or system.

3.4. EUT Configuration on Measurement

The configuration of EUT and its simulators were same as those used in conducted measurement. Please refer to 2.4.

3.5. Operating Condition of EUT

Same as conducted measurement which was listed in 2.5.

3.6. Test Procedure

The EUT and its simulators were placed on a turn table which was 0.8 meter above ground. The turn table rotate 360 degrees to determine the position of the maximum emission level. EUT was set 3 meters away from the receiving antenna which were mounted on a antenna tower. The antenna can move up and down between 1 meter and 4 meters to find out the maximum emission level. Broadband antenna (calibrated biconical and log periodical antenna) and dipole antenna were used as receiving antenna. Both horizontal and vertical polarization of the antenna were set on measurement. In order to find the maximum emission, all of the interface cables were manipulated according to ANSI C63.4-1992 on radiated measurement.

The bandwidth setting on the field strength meter (R&S TEST RECEIVER ESVP) was 120KHz.

The frequency range from 30MHz to 1000MHz was checked.

Two kinds of horizontal working frequency with three kinds of data cable were investigated separately within Anechoic Chamber and all the scanning waveform were attached in Appendix II.

Finally, re-measured the worst operating situation (64KHz with 3m D-Sub data cable) at No. 2 Open Field Test site and all the test results are listed in section 3.7.

Two kinds of display frequency :

	VGA480 (Hf : 31.5KHz)	1280 x 1024 (Hf : 64KHz)
(a) Dot Clock Frequency	25.17 MHz	108 MHz
(b) Vertical Frequency	60 Hz	60 Hz
(c) Horizontal Frequency	31.5 KHz	64 KHz

Three kinds of data cable :

- (1) 1.5m D-Sub data cable with two ferrite cores
- (2) 1.8m D-Sub data cable with two ferrite cores
- (3) 3.0m D-Sub data cable with two ferrite cores

3.7. Radiated Emission Noise Measurement Results

The frequency spectrum from 30 MHz to 1000MHz was investigated. All the emissions not reported below were too low against the FCC CLASS B limit.

Date of Test : Apr. 01, 1998 Temperature : 28 °C

EUT : 17" Color CRT Display Monitor Humidity : 55 %

Test Mode : 64KHz/1280*1024, 3m D-Sub Data Cable

Frequency MHz	Antenna Factor dB/m	Cable Loss dB	Meter Reading		Emission Level Horizontal dBuV/m	Limits dBuV/m	Margin dBuV/m
			Horizontal dBuV	Horizontal dBuV/m			
33.849	23.13	1.63	1.90	26.66	40.00	13.34	
40.621	19.91	1.83	- 2.30	19.44	40.00	20.56	
81.223	14.40	2.48	- 0.20	16.68	40.00	23.32	
108.302	18.33	2.87	5.80	27.00	43.50	16.50	
121.829	19.69	3.03	6.90	29.62	43.50	13.88	
135.360	20.61	3.26	6.70	30.57	43.50	12.93	
175.972	21.69	3.78	- 0.40	25.07	43.50	18.43	
182.739	21.89	3.84	1.80	27.53	43.50	15.97	
189.510	21.87	3.92	0.70	26.49	43.50	17.01	
203.048	22.27	4.08	0.20	26.55	43.50	16.95	
257.205	23.80	4.67	- 3.60	24.87	46.00	21.13	
291.032	25.57	4.98	1.00	31.55	46.00	14.45	
* 311.358	13.47	5.23	19.50	38.20	46.00	7.80	
324.895	13.76	5.42	16.50	35.68	46.00	10.32	
351.968	14.79	5.67	4.10	24.56	46.00	21.44	
460.252	17.32	6.74	- 1.50	22.56	46.00	23.44	
548.236	18.87	7.75	- 2.40	24.22	46.00	21.78	
622.684	19.54	7.88	- 1.00	26.42	46.00	19.58	
656.524	20.14	8.10	- 3.50	24.74	46.00	21.26	

- Remark :
1. All reading were Quasi-Peak values.
 2. The worst emission was detected at 311.358MHz with corrected signal level of 38.20dBuV/m (limit was 46dBuV/m) when the antenna was at horizontal polarization and was at 1.5m high and the turn table was at 200 ° .
 3. 0 ° is the table front facing the antenna. Degree was calculated from 0 ° clockwise facing the antenna.

Date of Test : Apr. 01, 1998 Temperature : 28 °C
 EUT : 17" Color CRT Display Monitor Humidity : 55 %
 Test Mode : 64KHz/1280*1024, 3m D-Sub Data Cable

Frequency MHz	Antenna Factor dB/m	Cable Loss dB	Meter Reading		Emission Level	
			Vertical dBuV	Vertical dBuV/m	Limits dBuV/m	Margin dBuV/m
33.806	22.23	1.63	- 0.80	23.06	40.00	16.94
40.615	18.74	1.83	- 0.80	19.77	40.00	20.23
54.152	14.70	2.04	4.10	20.84	40.00	19.16
81.239	15.69	2.48	- 1.00	17.17	40.00	22.83
94.786	17.77	2.69	6.00	26.46	43.50	17.04
108.305	17.06	2.87	9.60	29.53	43.50	13.97
121.837	18.20	3.03	5.50	26.73	43.50	16.77
135.364	19.14	3.26	5.10	27.50	43.50	16.00
148.898	19.91	3.40	- 1.10	22.21	43.50	21.29
175.970	22.16	3.78	- 3.10	22.84	43.50	20.66
270.720	25.37	4.81	- 1.70	28.48	46.00	17.52
304.552	14.17	5.19	10.90	30.26	46.00	15.74
* 311.379	13.99	5.23	20.40	39.62	46.00	6.38
324.889	14.23	5.42	18.20	37.85	46.00	8.15
338.434	14.55	5.57	11.20	31.32	46.00	14.68
392.577	15.91	6.06	4.70	26.67	46.00	19.33
446.723	16.70	6.57	1.80	25.07	46.00	20.93
541.475	19.23	7.70	1.40	28.33	46.00	17.67
663.299	19.96	8.20	- 0.10	28.06	46.00	17.94

- Remark :
1. All reading were Quasi-Peak values.
 2. The worst emission was detected at 311.379MHz with corrected signal level of 39.62dBuV/m (limit was 46dBuV/m) when the antenna was at vertical polarization and was at 1m high and the turn table was at 170 ° .
 3. 0 ° is the table front facing the antenna. Degree was calculated from 0 ° clockwise facing the antenna.

APPENDIX I

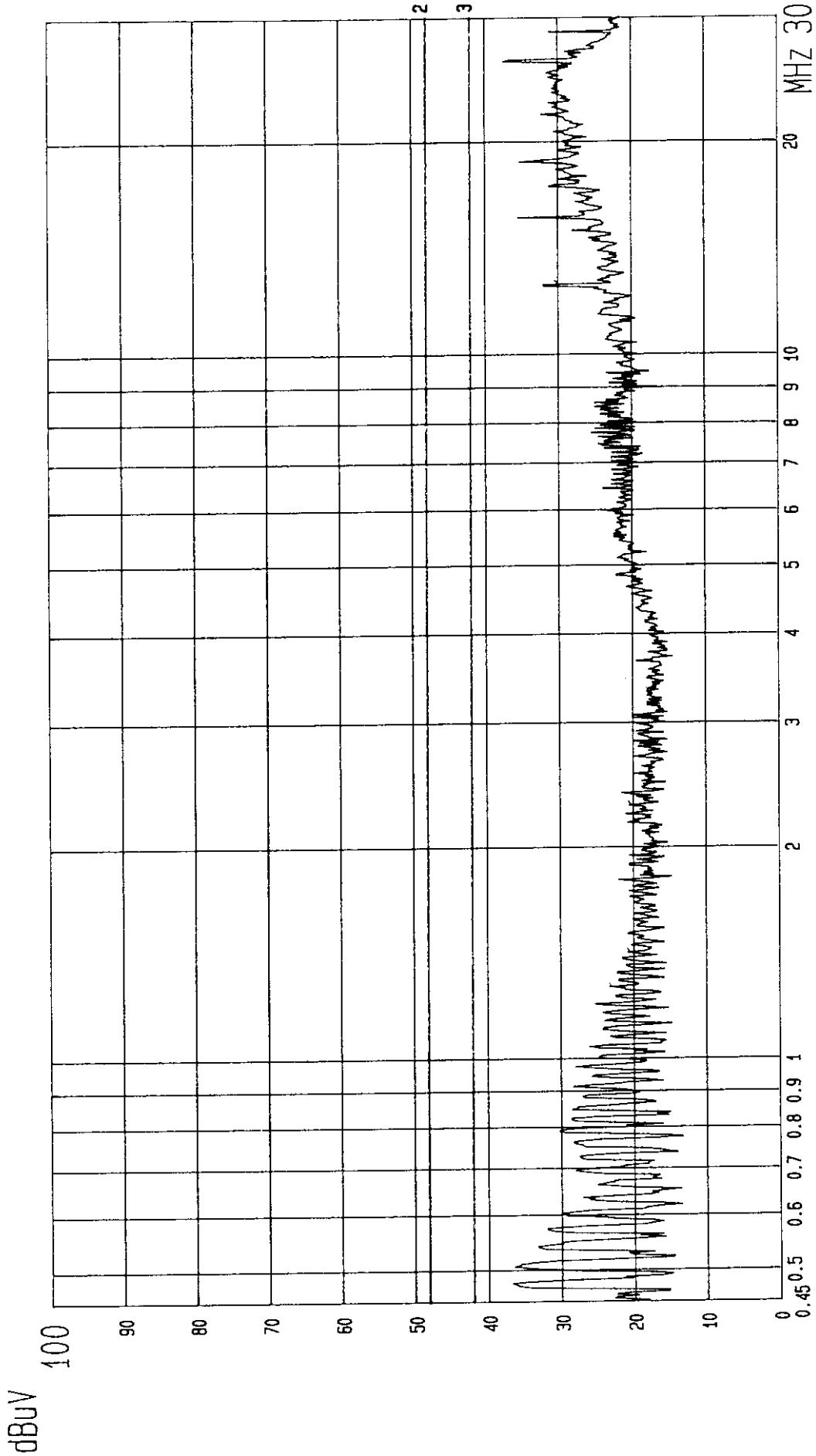

--- Date 02.APR.'98 Time 10:14:27
 MATSUSHITA EUT: MONITOR M/N: TX-D7S36NM; VCDTS21406-2* PAGE: 001.
 LINE: VA. MEMO: 31.5KHz (640X480; 60Hz); 1.5m D-SUB (PEAK VALUE) ITEM:

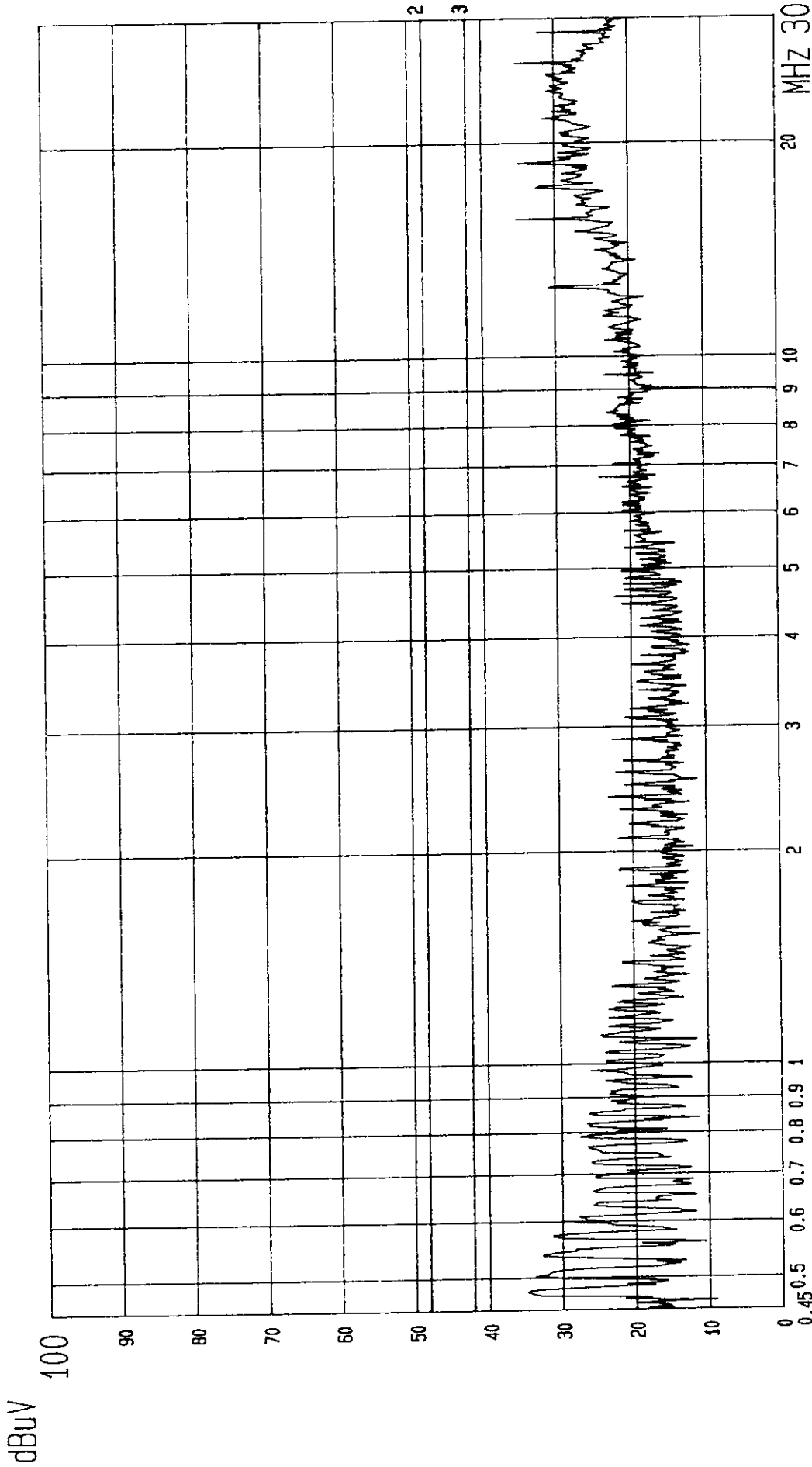

Date 02.APR.'98 Time 10:16:02
 MATSUSHITA EUT: MONITOR
 LINE: VB. MEMO: 31.5KHz (640X480; 60Hz); 1.5m D-SUB (PEAK VALUE)
 M/N: TX-D7S36NM; VCDTS21406-2X
 PAGE: 002. ITEM: C.

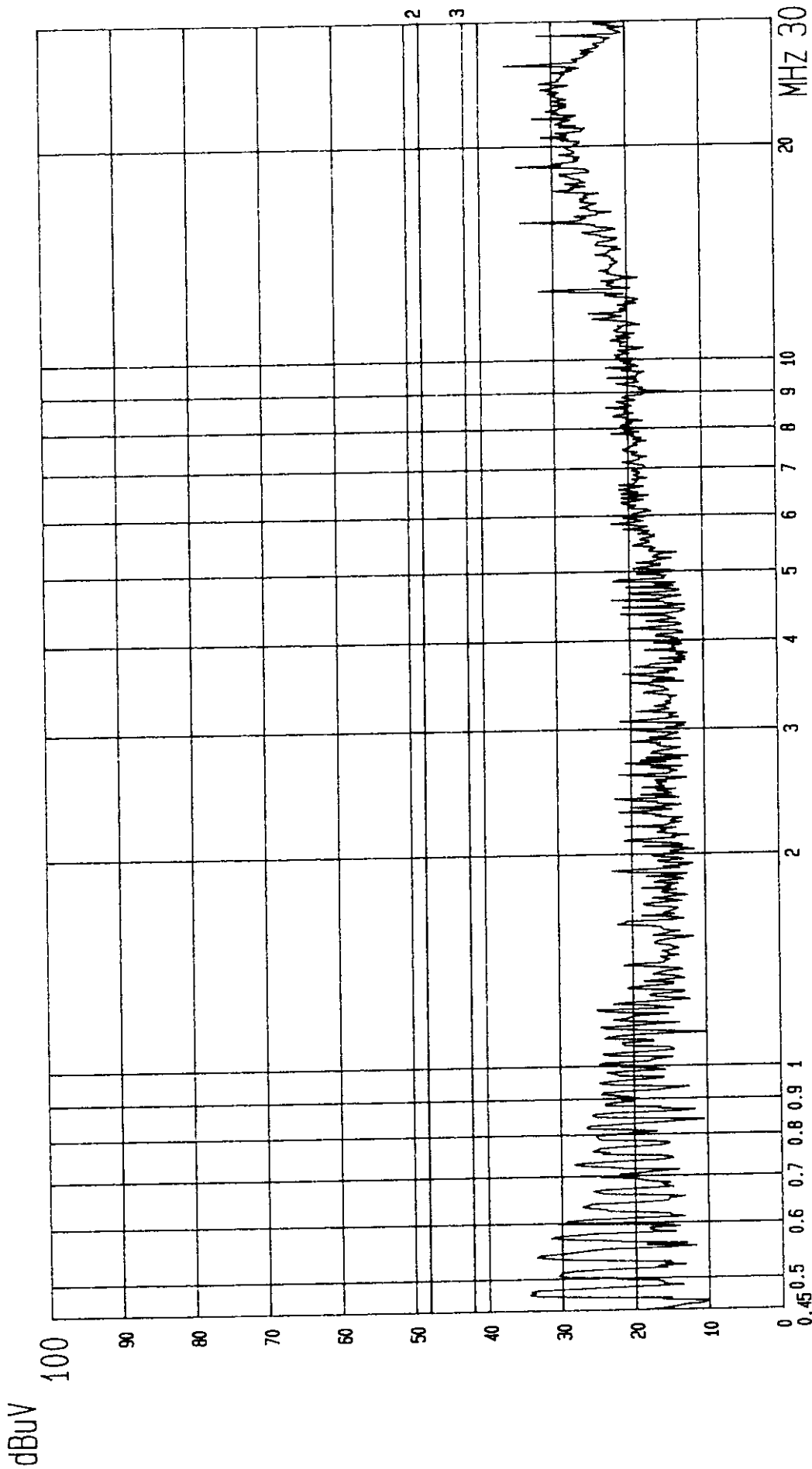

--- Date 02.APR.'98 Time 10:18:29
 MATSUSHITA EUT: MONITOR
 LINE: VB MEMO: 31.5KHz (640X480; 60Hz); 1.8m D-SUB (PEAK VALUE)
 M/N: TX-D7S36NM; VCDTS21406-2*
 PAGE: 003.
 ITEM: C.

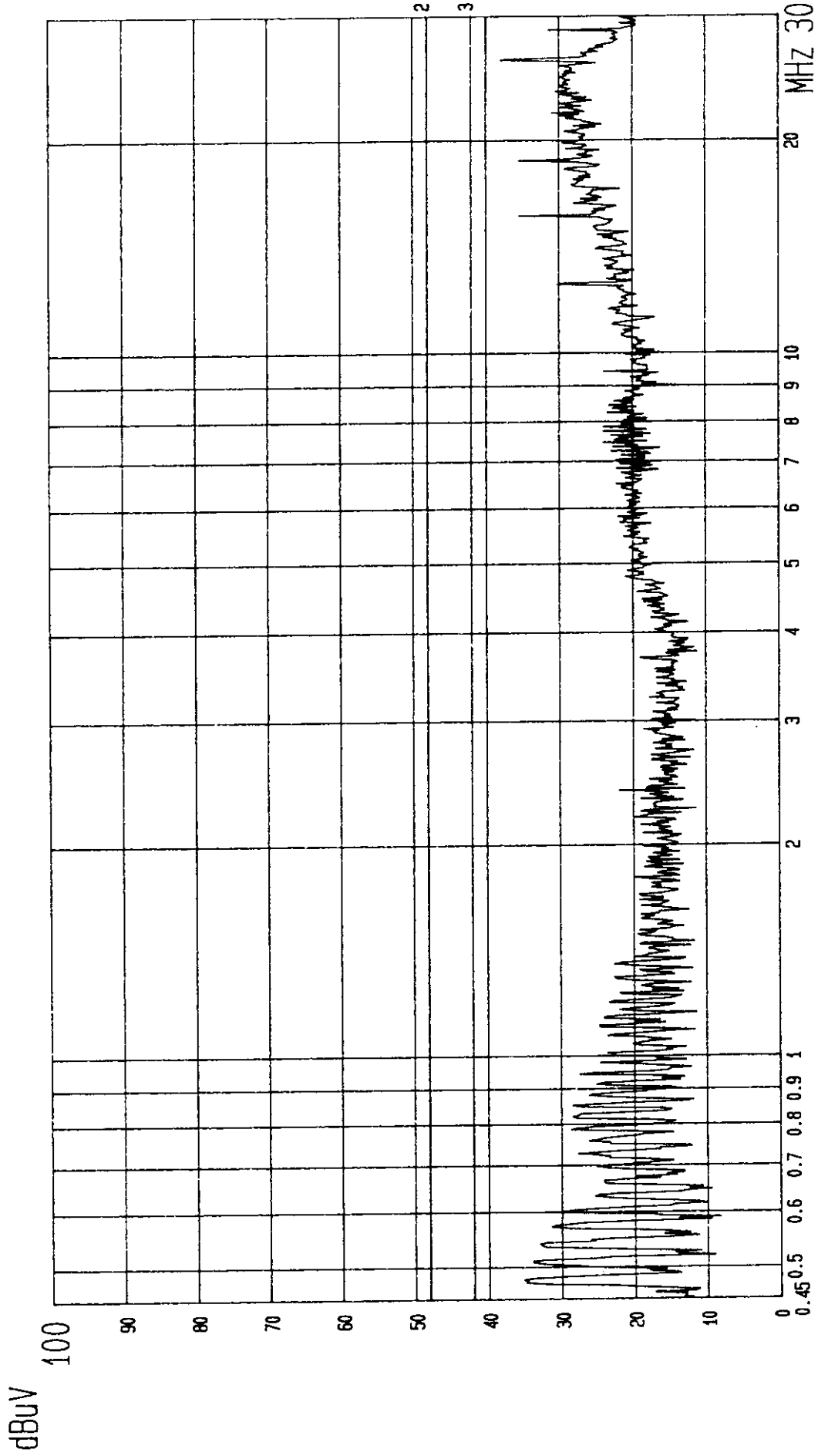

--- Date 02.APR '98 Time 10:20:13
 MATSUSHITA EUT: MONITOR
 LINE: VA. MEMO: 31.5KHZ (640X480; 60HZ); 1.8m D-SUB (PEAK VALUE)
 M/N: TX-D7S36NM; VCDTS21406-2*
 PAGE: 004. ITEM:

dBuV

100

90

80

70

60

50

40

30

20

10

0

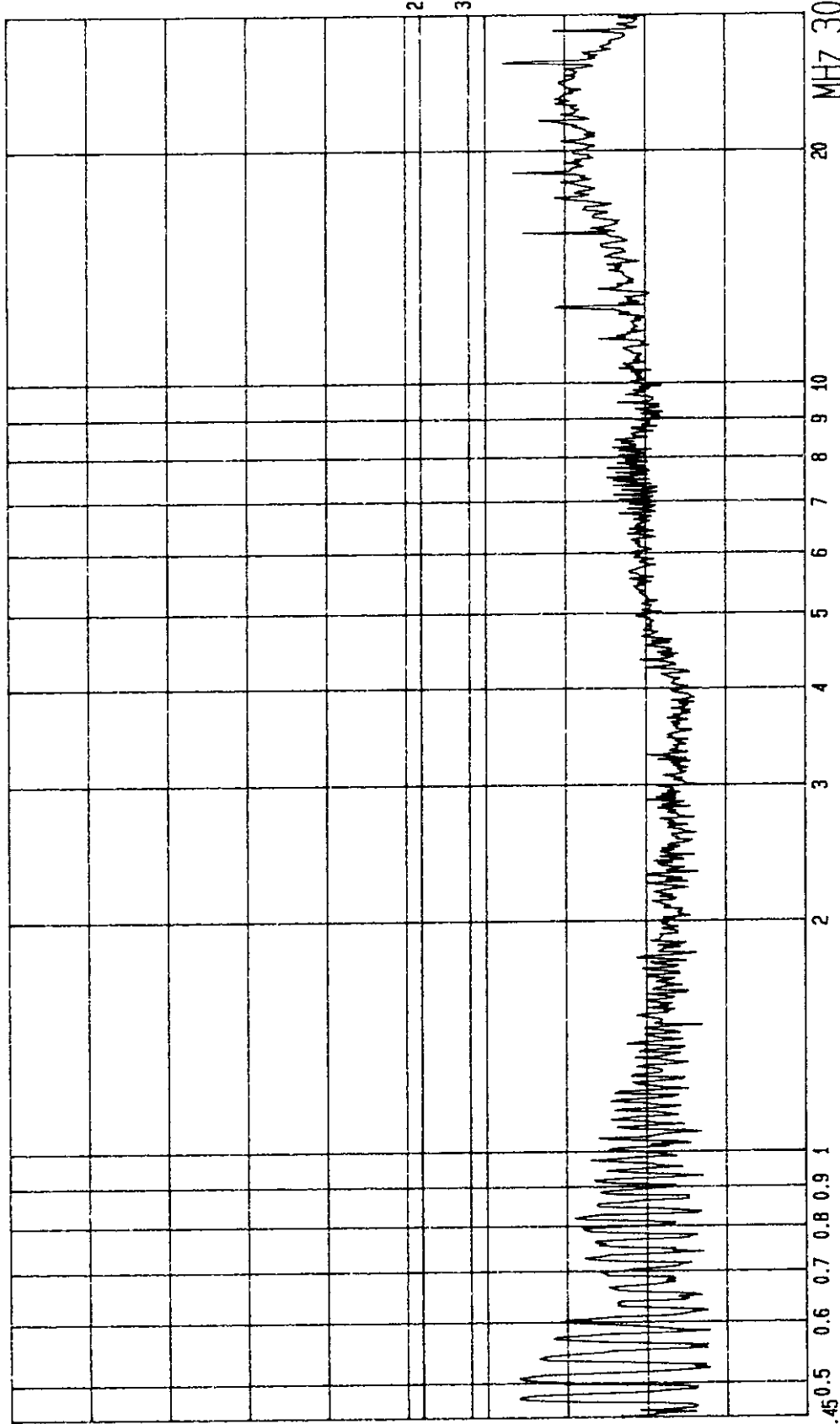

--- Date 02.APR.'98 Time 10:22:00

MATSUSHITA
LINE: VA.

EUT: MONITOR

MEMO: 31.5KHz (640X480; 60Hz); 3.0m D-SUB

M/N: TX-D7S36NM; VC DTS21406-2*
(PEAK VALUE)

PAGE: 005.
ITEMC.

MHZ 30

20

10

9

8

7

6

5

4

3

2

1

0.9

0.8

0.7

0.6

0.5

0.45

2

3

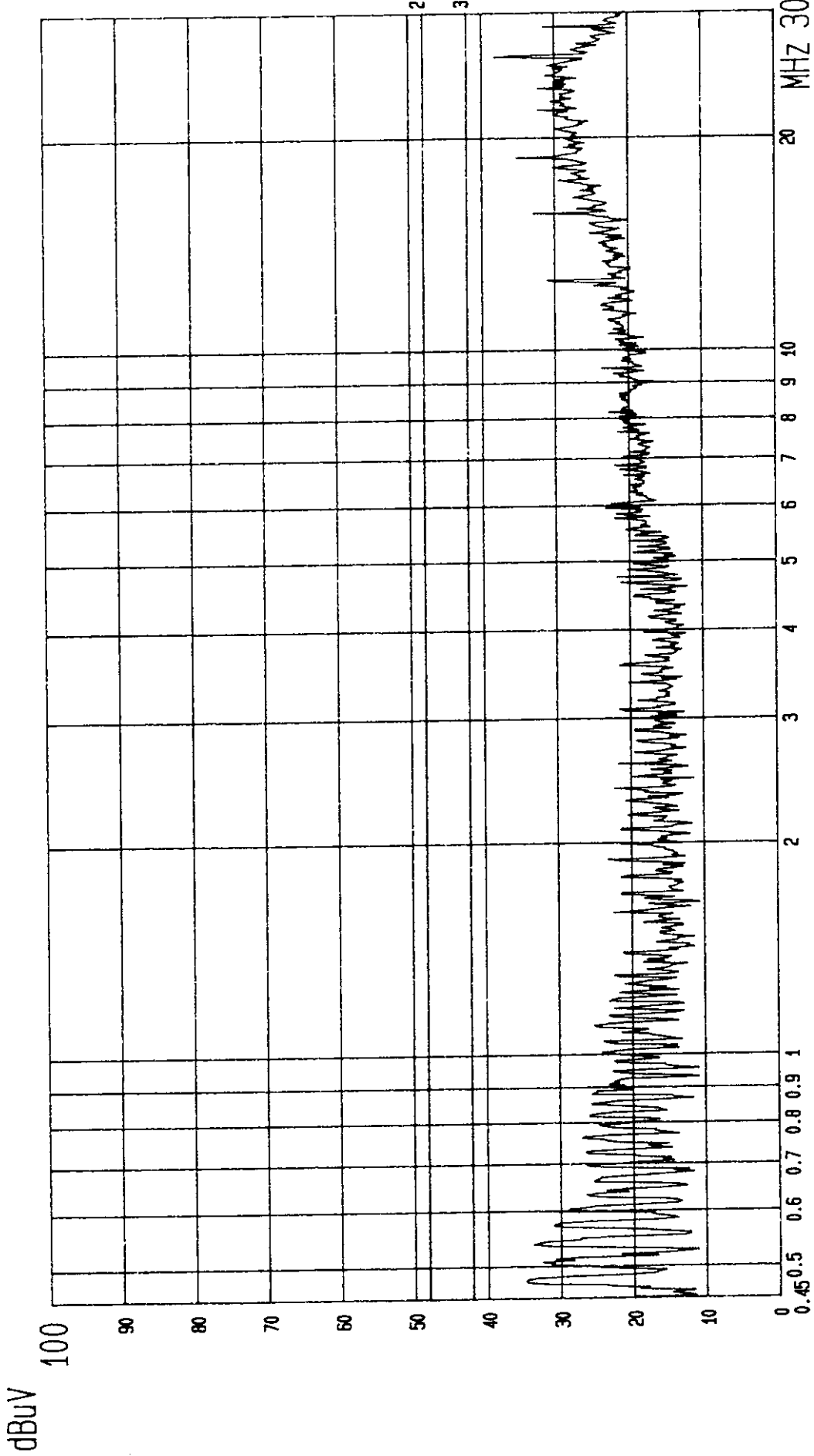

--- Date 02.APR.'98 Time 10:23:45

MATSUSHITA

EUT: MONITOR

MEMO: 31.5KHz (640X480; 60Hz); 3.0m D-SUB (PEAK VALUE)

M/N: TX-D7S36NM; VCDTS21406-2*
PAGE: 006.
ITEMC.

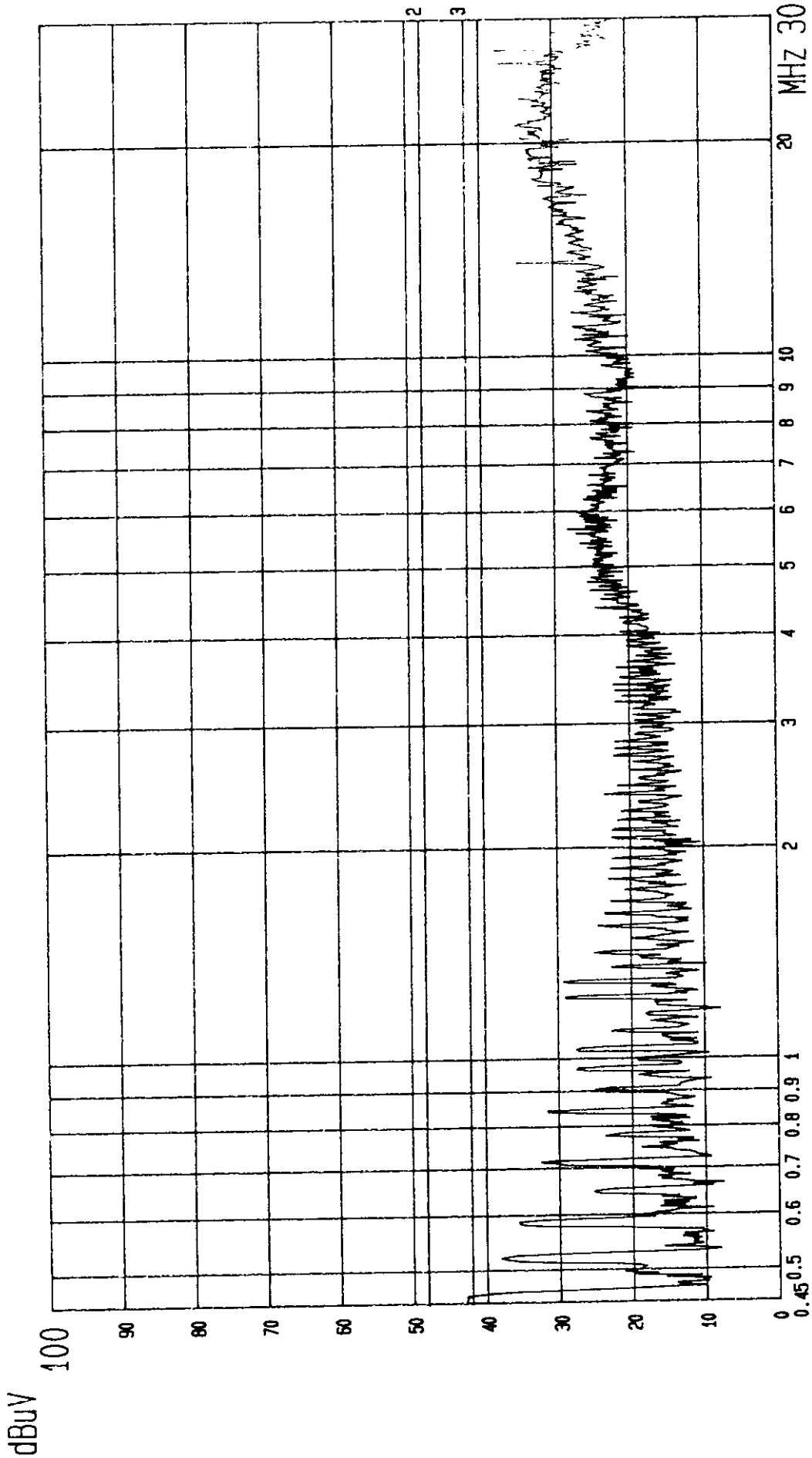

Date 02.APR.'98 Time 10:31:57
 MATSUSHITA EUT: MONITOR
 LINE: VA. MEMO: 64KHZ (1280X1024; 60HZ); 1.8m D-SUB (PEAK VALUE)
 M/N: TX-D7S36NM; VCDTS21406-2*
 PAGE: 009.
 ITEM: C.

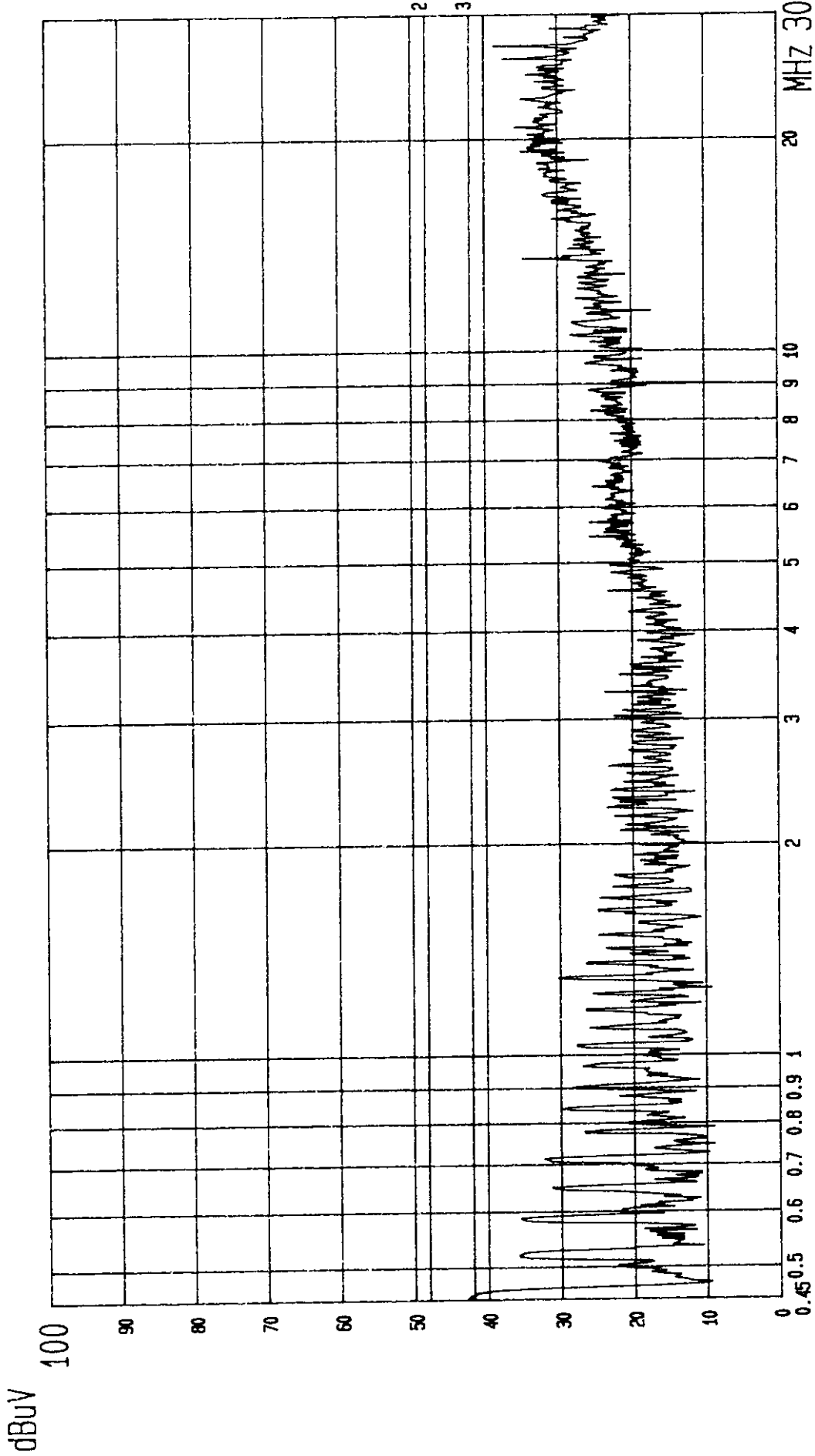

--- Date 02.APR.'98 Time 10:33:33
 MATSUSHITA EUT: MONITOR M/N: TX-D7S36NM; VCDTS21406-2*
 LINE: VB. MEMO: 64KHZ (1280X1024; 60Hz); 1.8m D-SUB (PEAK VALUE) PAGE: 010.
 ITEM: C

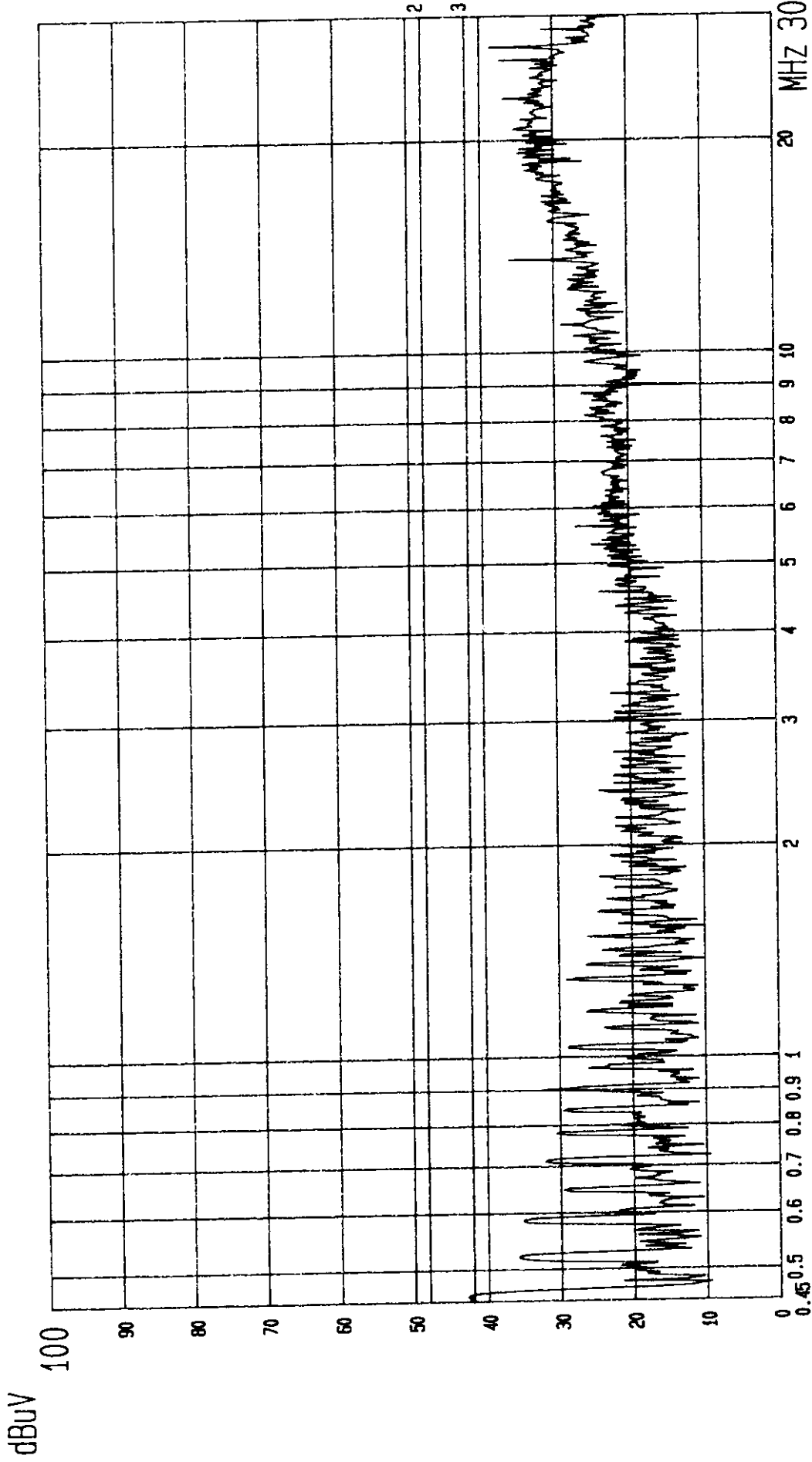

--- Date 02.APR.'98 Time 10:35:18

MATSUSHITA

EUT: MONITOR

MEMO: 64KHZ (1280X1024; 60HZ); 1.5m D-SUB

M/N: TX-D7S36NM; VCDTS21406-2*

(PEAK VALUE)

ITEMC.

PAGE: 011.

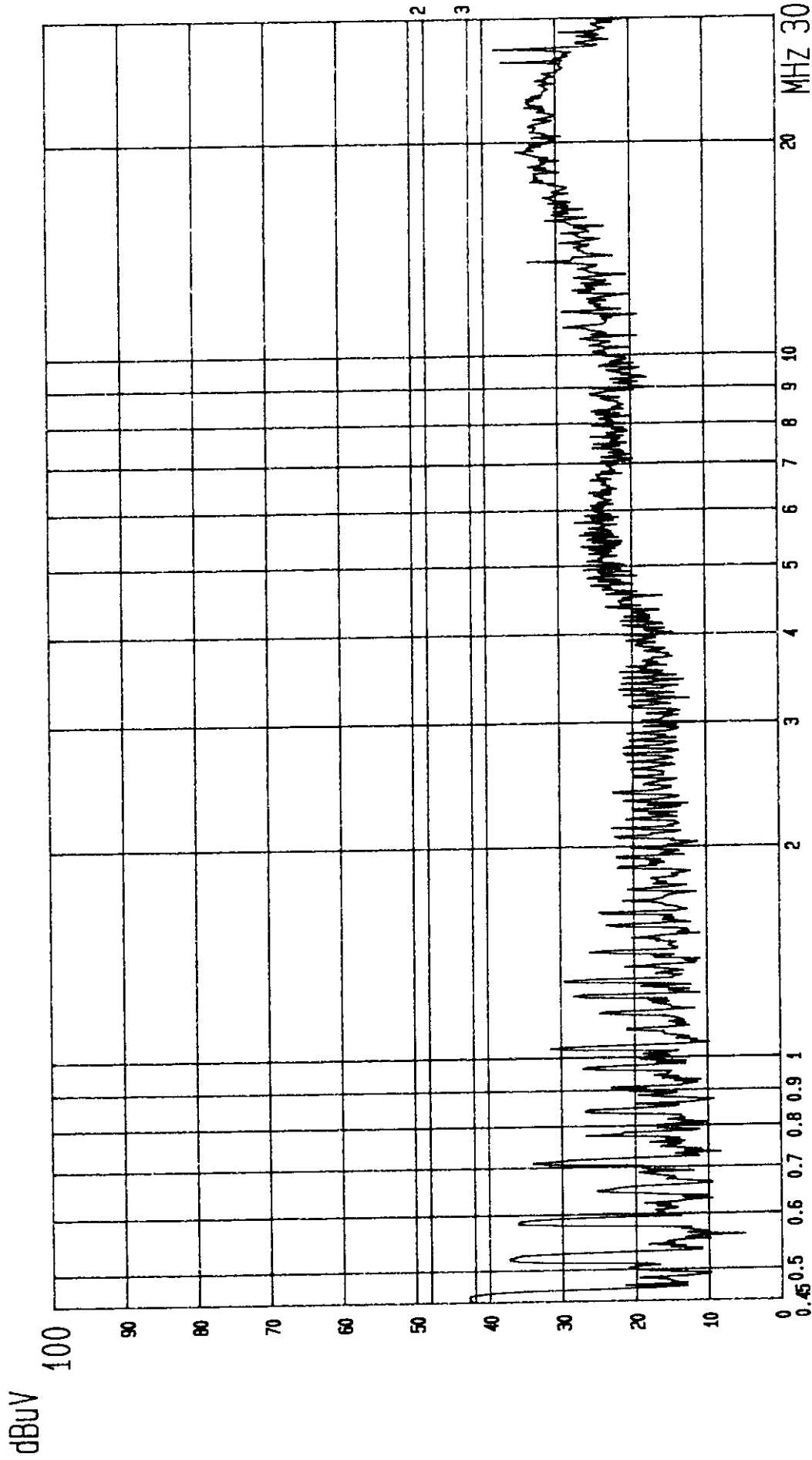

--- Date 02.APR.'98 Time 10:37:17

MATSUSHITA EUT: MONITOR

LINE: VA. MEMO: 64KHZ (1280X1024; 60HZ); 1.5m D-SUB

M/N: TX-D7S36NM; VC DTS21406-2*

(PEAK VALUE)

PAGE: 012.

TTEMC.

APPENDIX II

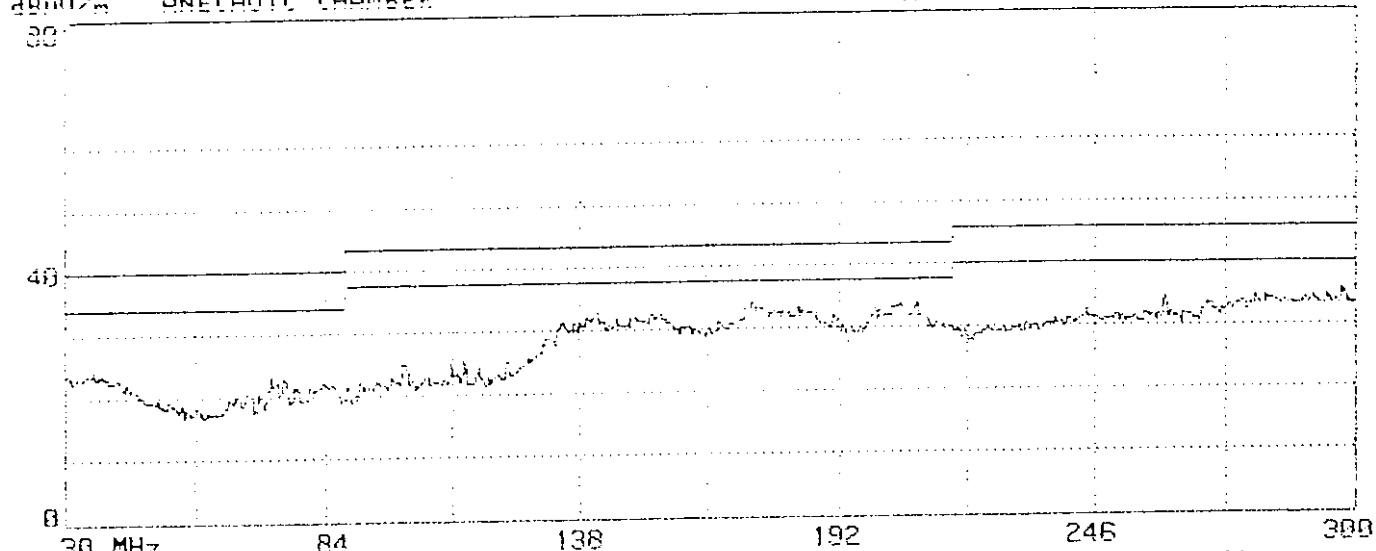

Limit : FCC CLASS-B 3m Probe: BB091050(A3)1223 HORIZONTAL
EUT : 17" MONITOR M/N:TX-D7S38NM Power: 120Vac/60Hz
Margin: 6dB Standard: 0 Trace: 2117, 0, 0, 0, 0
Memo : 31.5KHz(640X480;60Hz)1.5m0-SUB CABLE

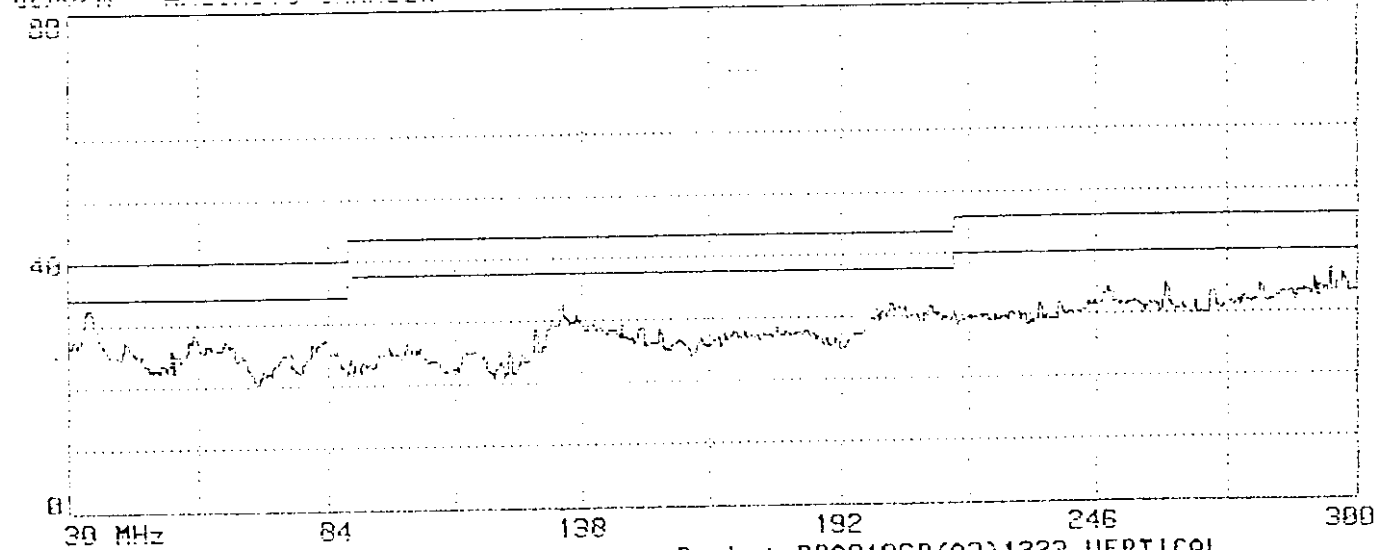

Limit : FCC CLASS-B 3m Probe: BB091050(A3)1223 VERTICAL
EUT : 17" MONITOR M/N:TX-D7S38NM Power: 120Vac/60Hz
Margin: 6dB Standard: 0 Trace: 2118, 0, 0, 0, 0
Memo : 31.5KHz(640X480;60Hz)1.5m0-SUB CABLE

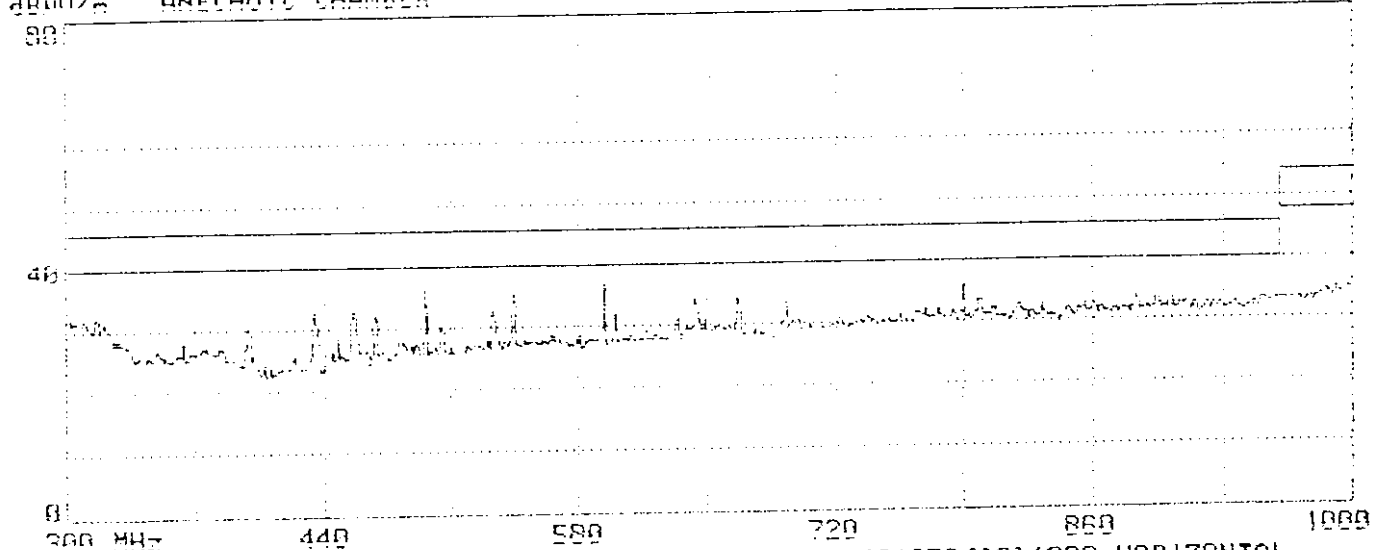

300 MHz 440 580 720 860 1000
 Limit : FCC CLASS-B 3m Probe: JUALP91079 (A3) 1223 HORIZONTAL
 EUT : 17" MONITOR M/N: TX-07336NH Power : 120Vac/60Hz
 Margin: 6dB Standard: 0 Trace: 2115, 0, 0, 0, 0
 Memo : 31.5KHz (640X480;60Hz) 1.5m0-SUB CABLE

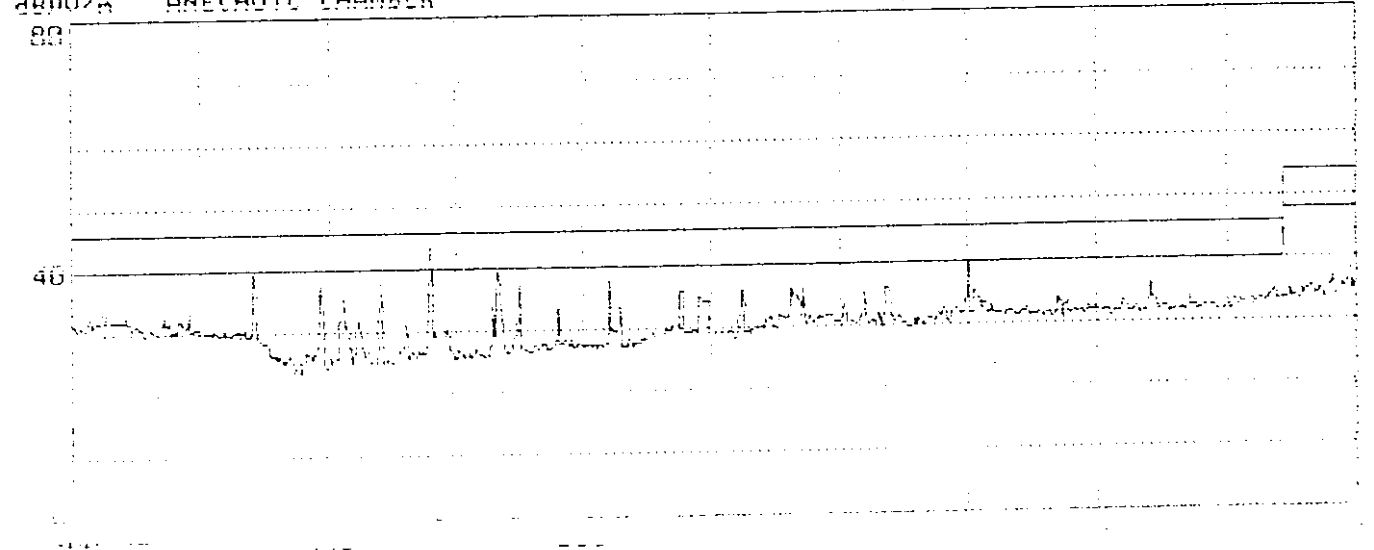

300 MHz 440 580 720 860 1000
 Limit : FCC CLASS-B 3m Probe: JUALP91079 (A3) 1223 VERTICAL
 EUT : 17" MONITOR M/N: TX-07336NH Power : 120Vac/60Hz
 Margin: 6dB Standard: 0 Trace: 2116, 0, 0, 0, 0
 Memo : 31.5KHz (640X480;60Hz) 1.5m0-SUR CABLE

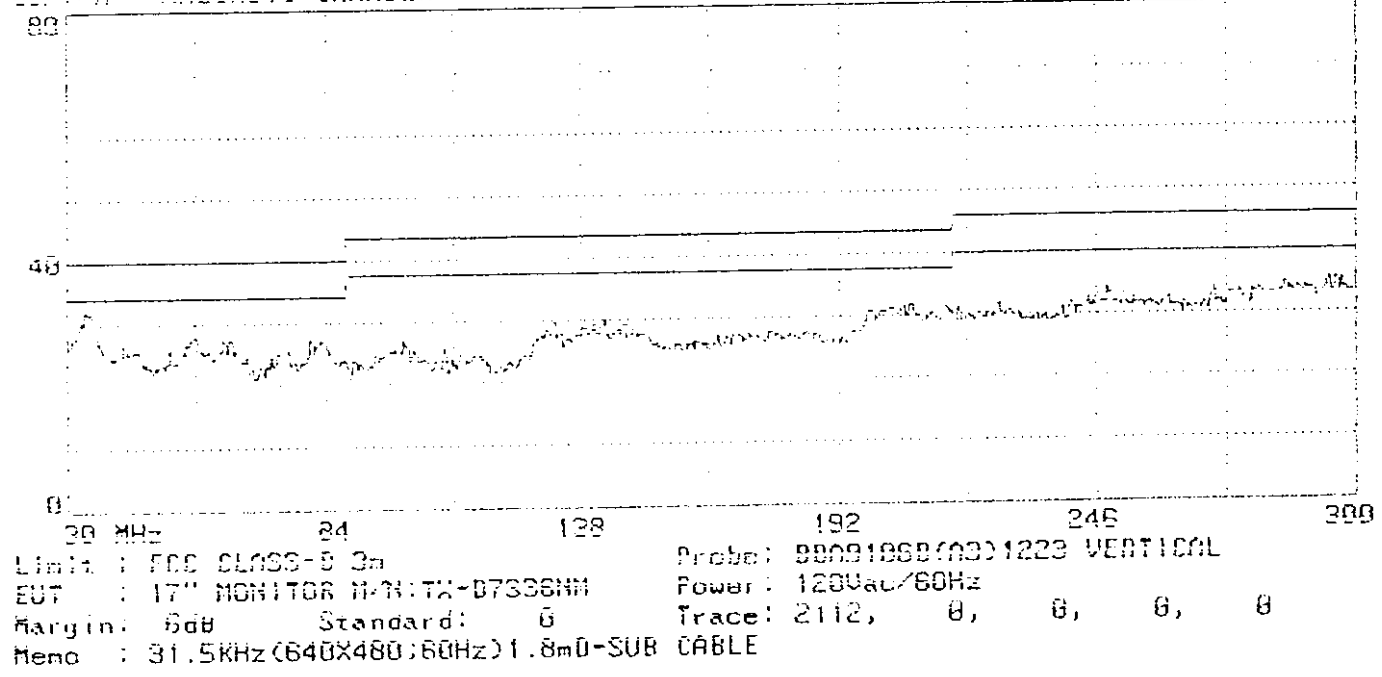
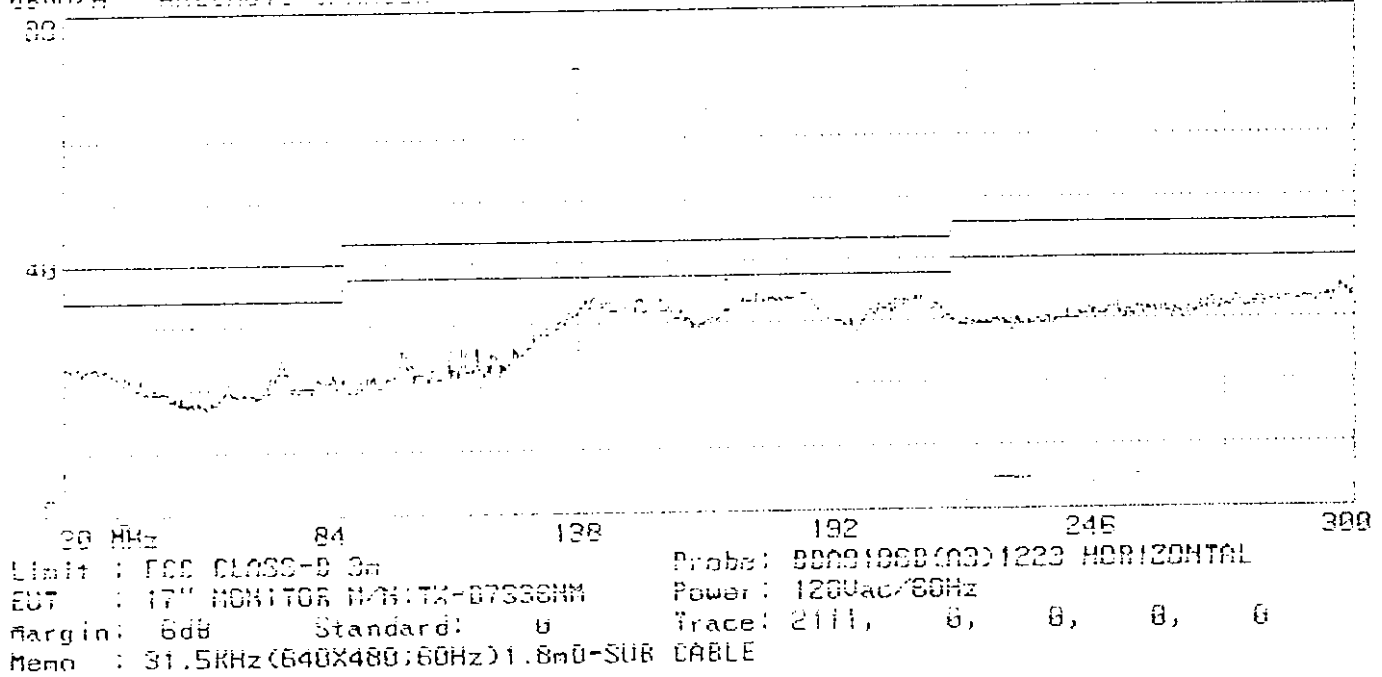

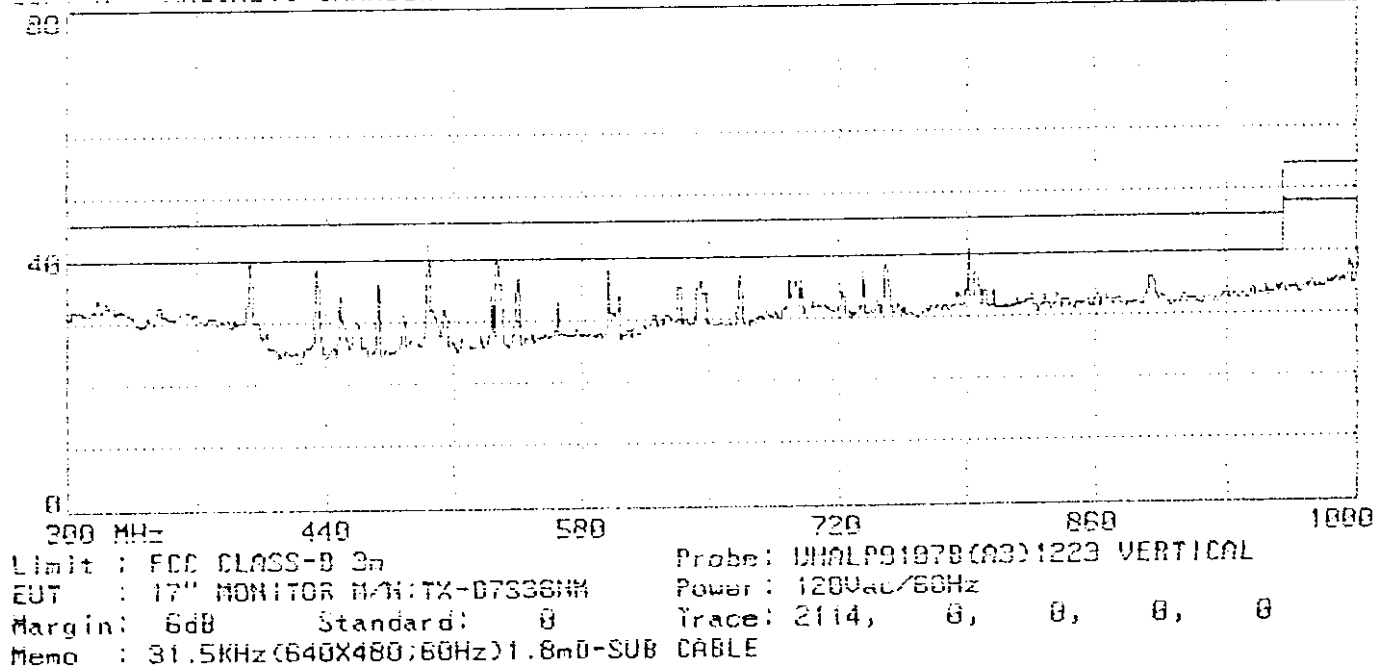
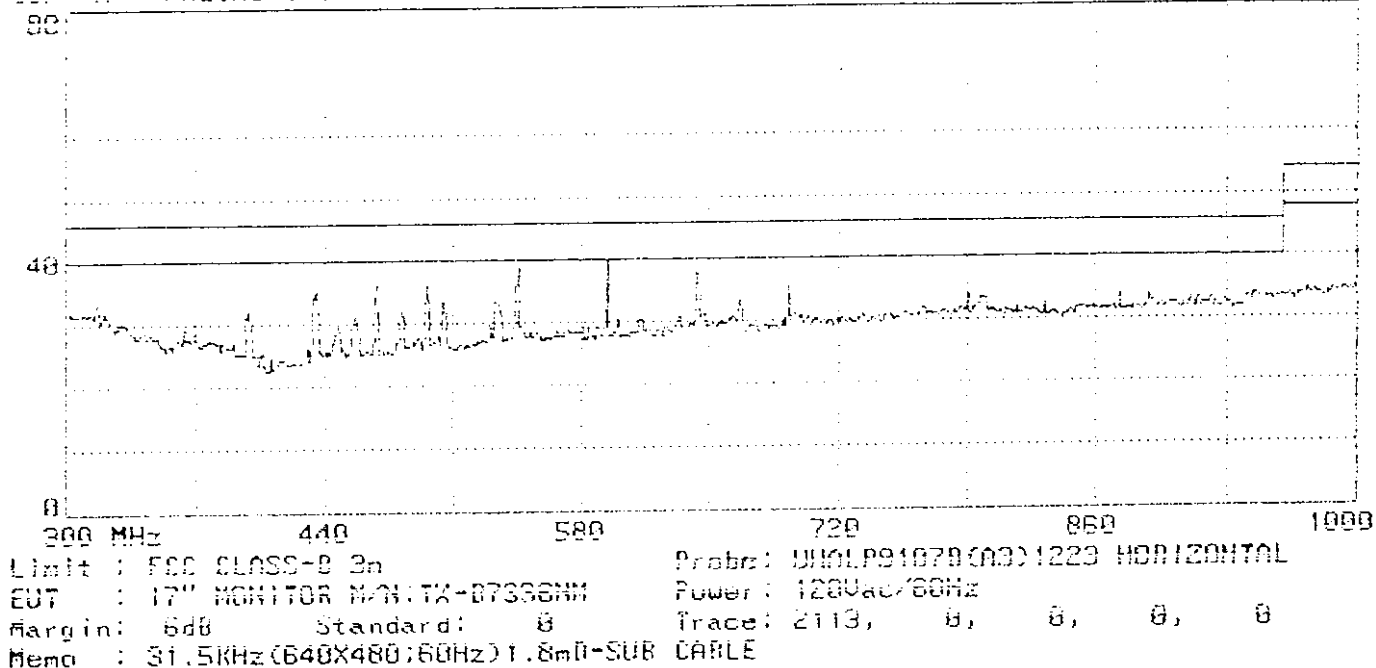

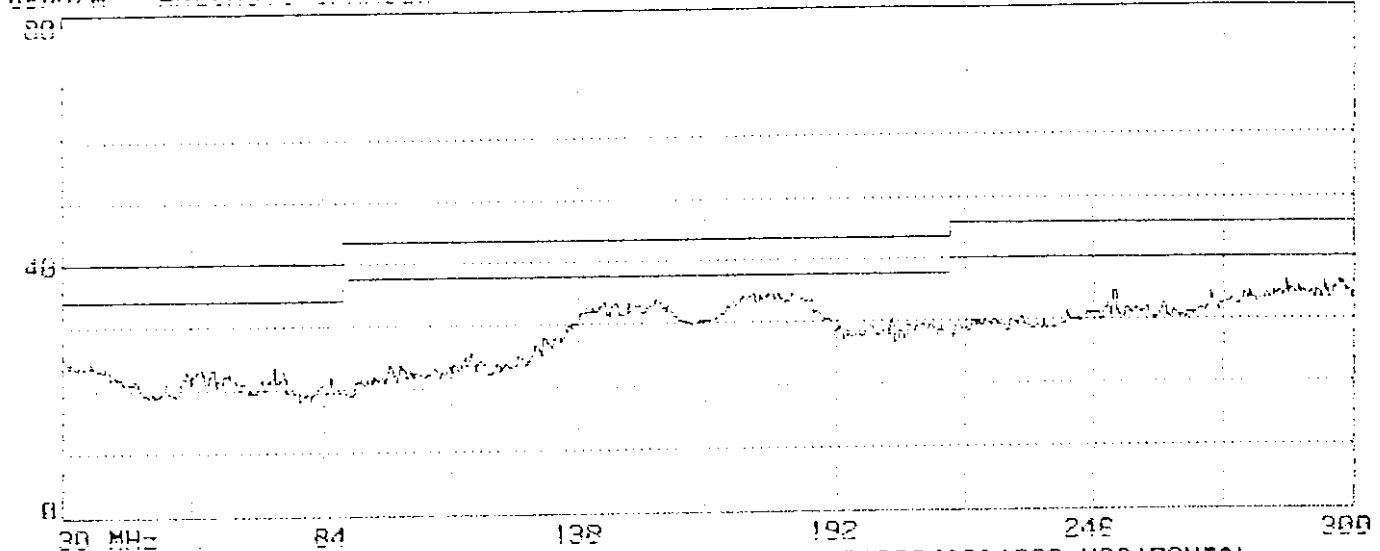

Limit : FCC CLASS-B 3m Probe: 99091869(03)1223 HORIZONTAL
EUT : 17" MONITOR M/N:TX-D7336NM Power: 120Vac/60Hz
Margin: 6dB Standard: 0 Trace: 2109, 0, 0, 0, 0
Memo : 31.5KHz(640X480:60Hz)3m0-SUB CABLE

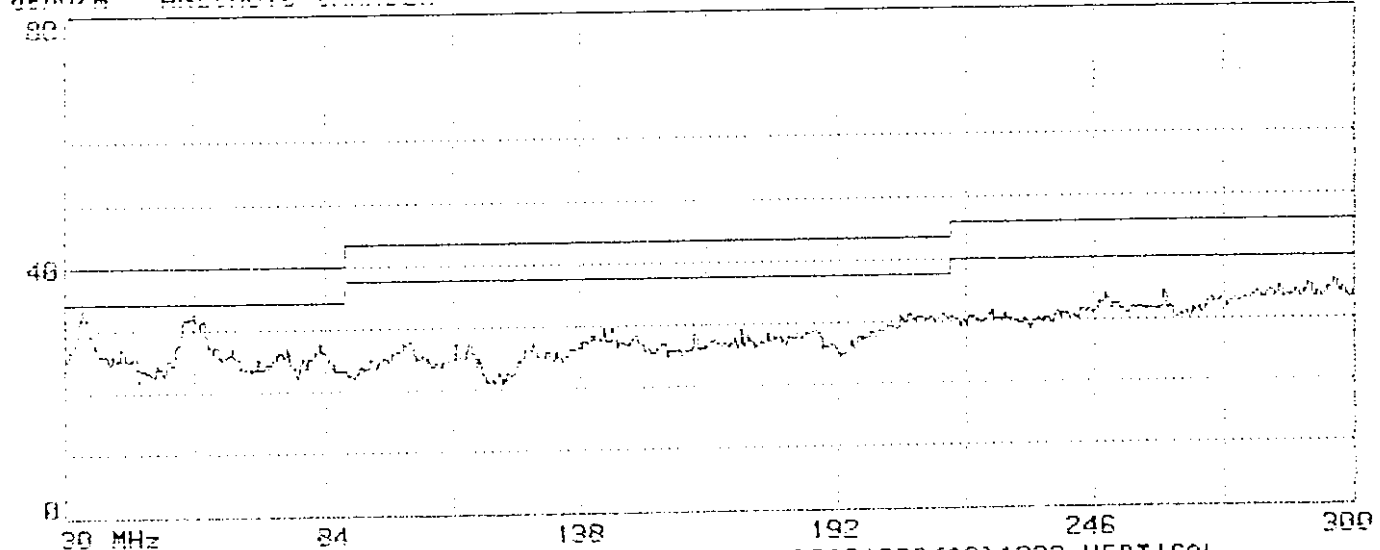

Limit : FCC CLASS-B 3m Probe: 99091869(03)1223 VERTICAL
EUT : 17" MONITOR M/N:TX-D7336NM Power: 120Vac/60Hz
Margin: 6dB Standard: 0 Trace: 2110, 0, 0, 0, 0
Memo : 31.5KHz(640X480:60Hz)3m0-SUB CABLE

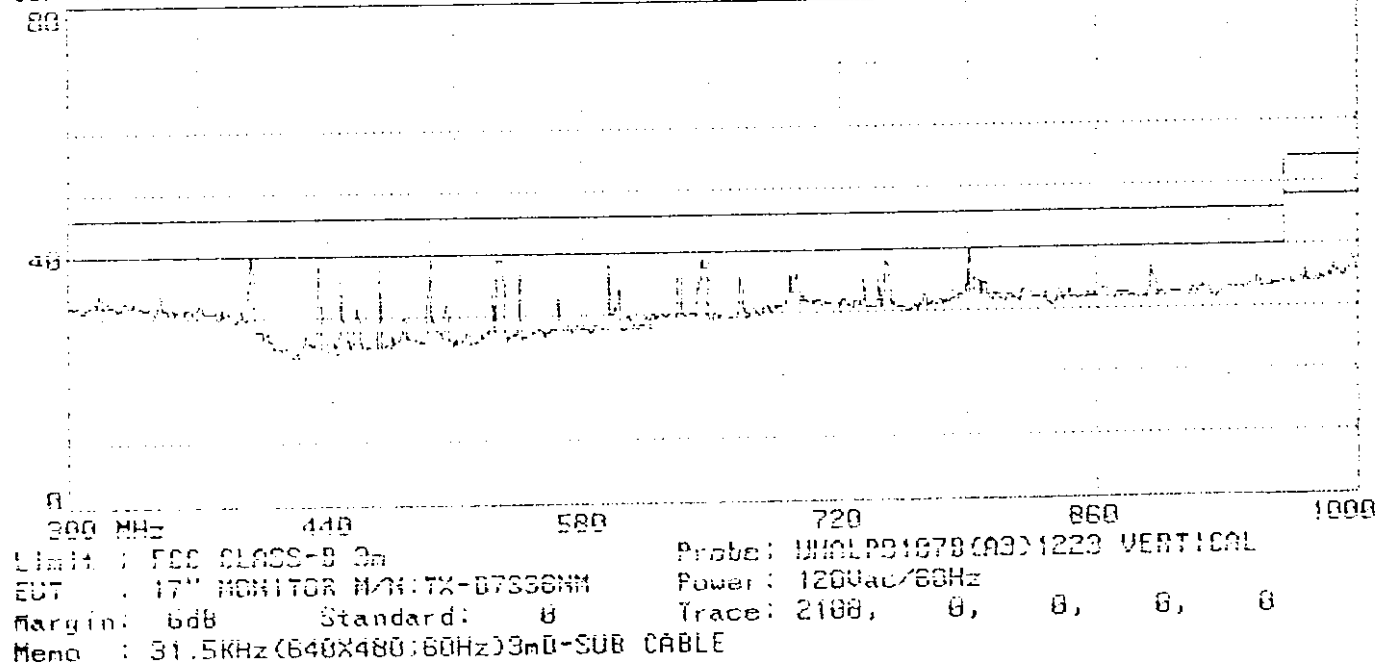
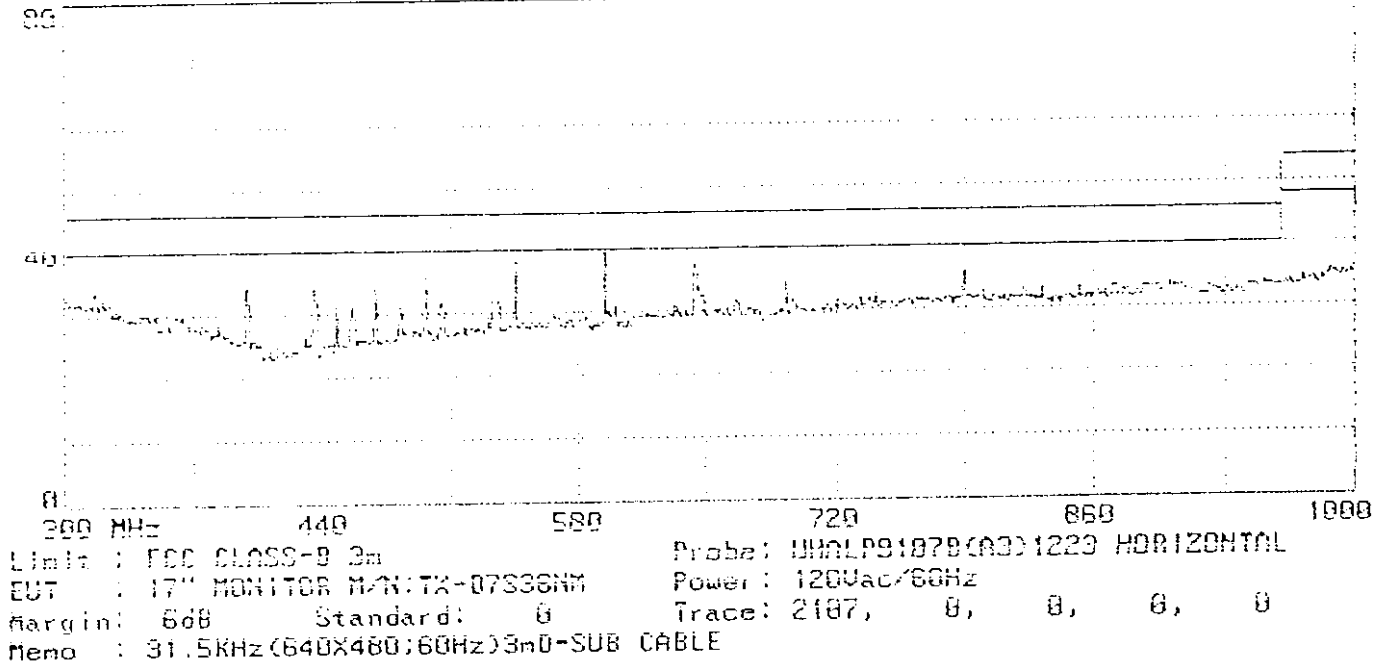

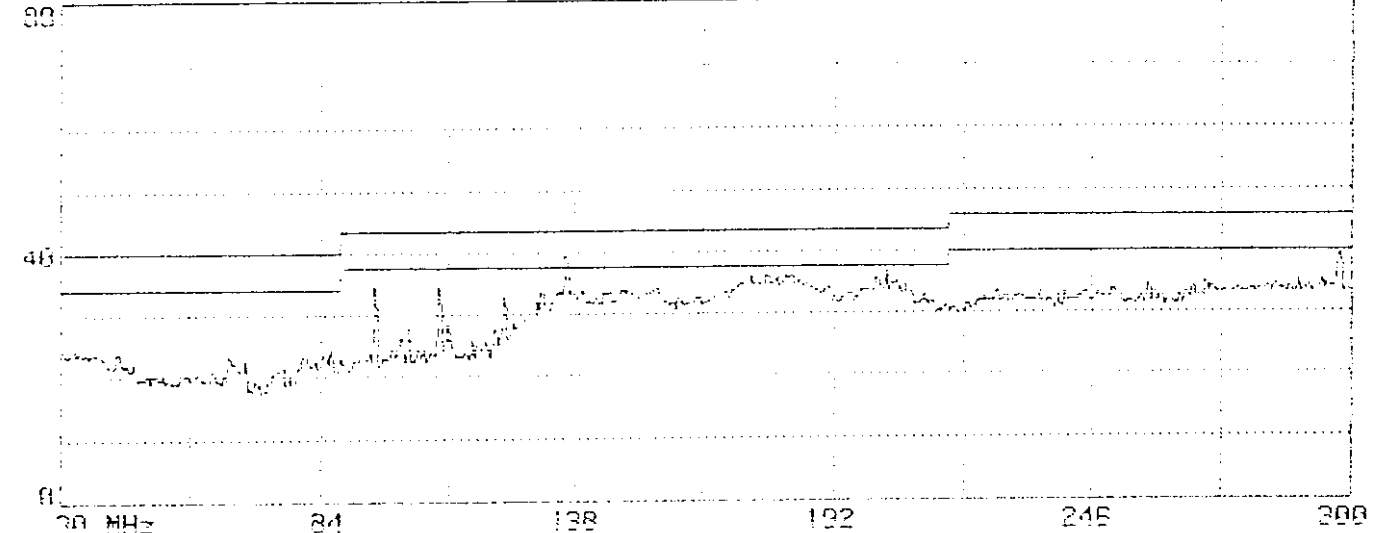

Limit : FCC CLASS-B 3m Probe: 00001000(03)1223 HORIZONTAL
EUT : 17" MONITOR N/N:TX-07336MM Power: 120Vac/60Hz
Margin: 6dB Standard: 0 Trace: 2119, 0, 0, 0, 0
Memo : 64KHz(1280X1024;60Hz)1.5m0-SUB CABLE

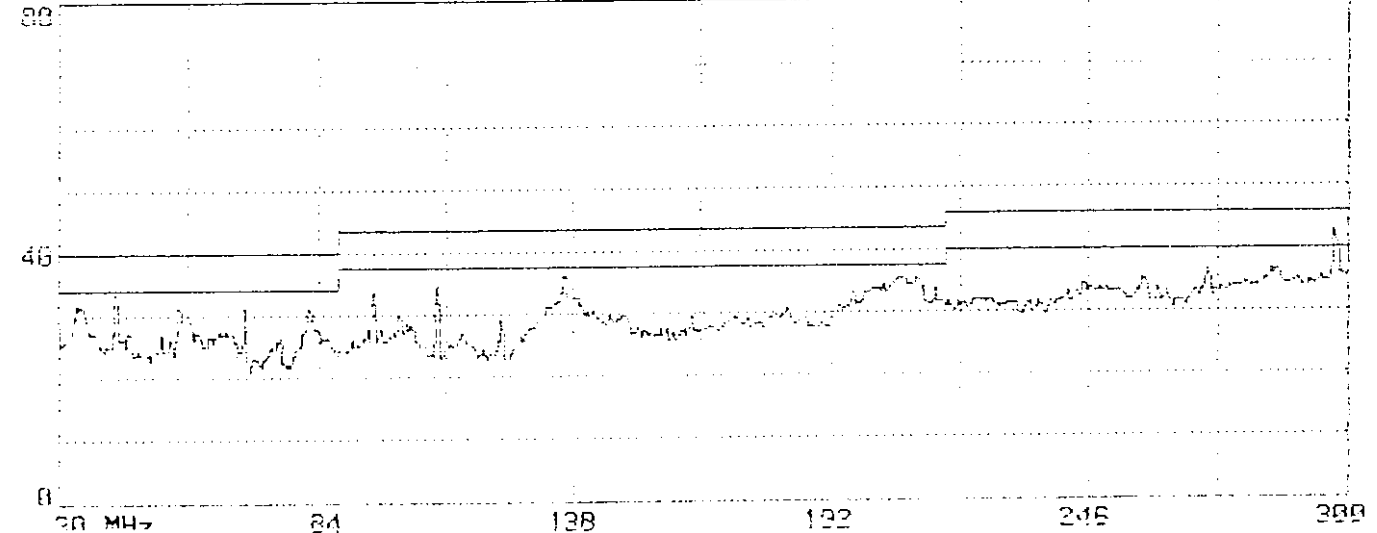

Limit : FCC CLASS-B 3m Probe: 00001000(03)1223 VERTICAL
EUT : 17" MONITOR N/N:TX-07336MM Power: 120Vac/60Hz
Margin: 6dB Standard: 0 Trace: 2120, 0, 0, 0, 0
Memo : 64KHz(1280X1024;60Hz)1.5m0-SUB CABLE

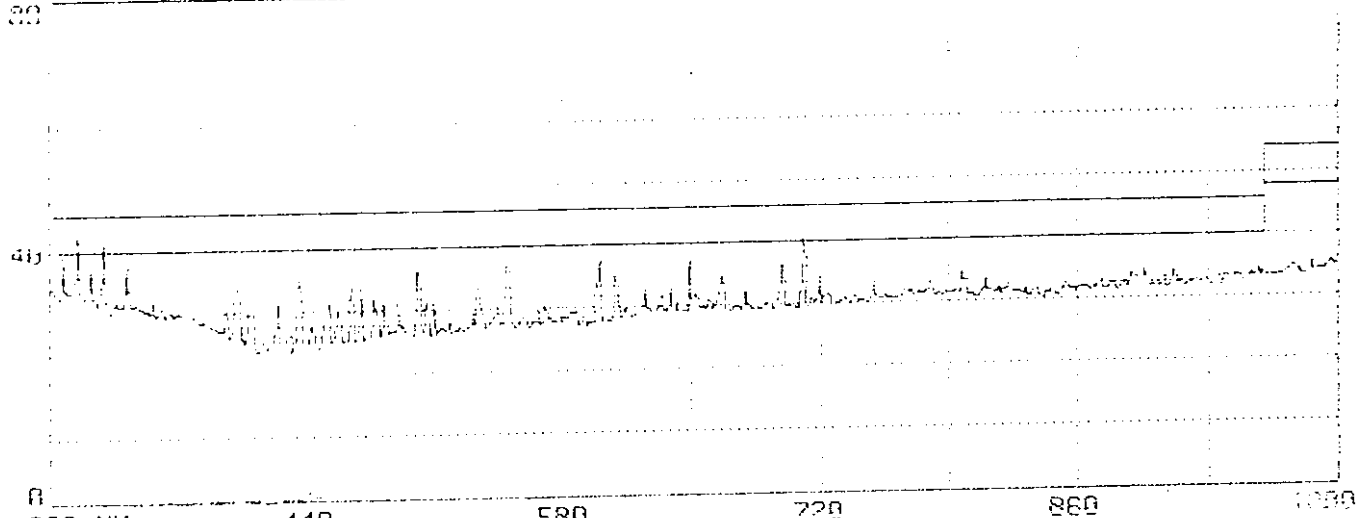

Limit : FCC CLASS-B 3m
 EUT : 17" MONITOR M/R:TX-D7336NM
 Margin: 6dB Standard: 0
 Memo : 64KHz (1280X1024;60Hz) 1.5mD-SUB CABLE
 Probe: UHALP9107B(A3)1223 HORIZONTAL
 Power: 120Vac/60Hz
 Trace: 2121, 0, 0, 0, 0

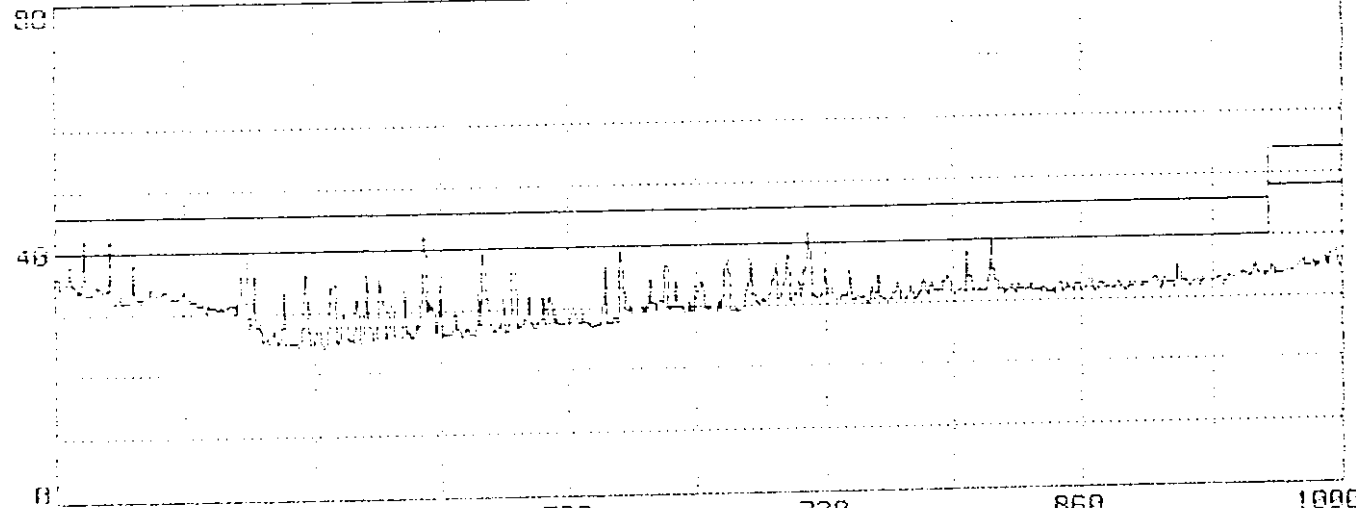

Limit : FCC CLASS-B 3m
 EUT : 17" MONITOR M/R:TX-D7336NM
 Margin: 6dB Standard: 0
 Memo : 64KHz (1280X1024;60Hz) 1.5mD-SUB CABLE
 Probe: UHALP9107B(A3)1223 VERTICAL
 Power: 120Vac/60Hz
 Trace: 2122, 0, 0, 0, 0

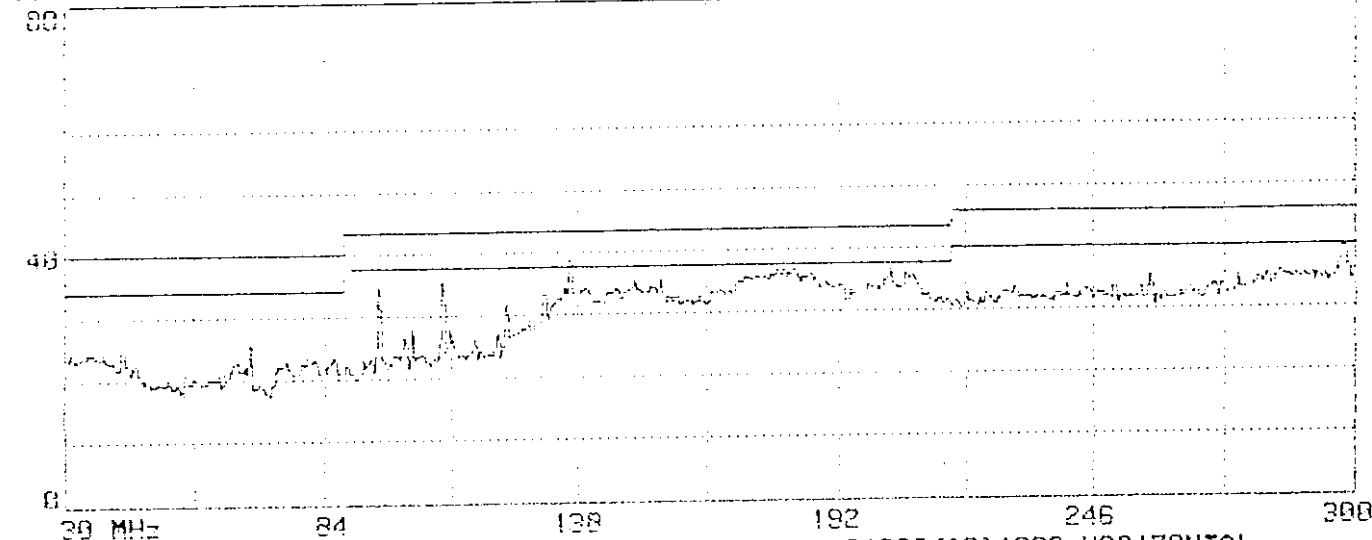

Limit : FCC CLASS-B 3m
 EUT : 17" MONITOR N/A:TX-D7S36NM
 Margin: 6dB Standard: 0
 Memo : 64KHz(1280X1024;60Hz)1.8m0-SUB CABLE
 Probe: 00A91050(A3)1223 HORIZONTAL
 Power: 120Vac/60Hz
 Trace: 2125, 0, 0, 0, 0

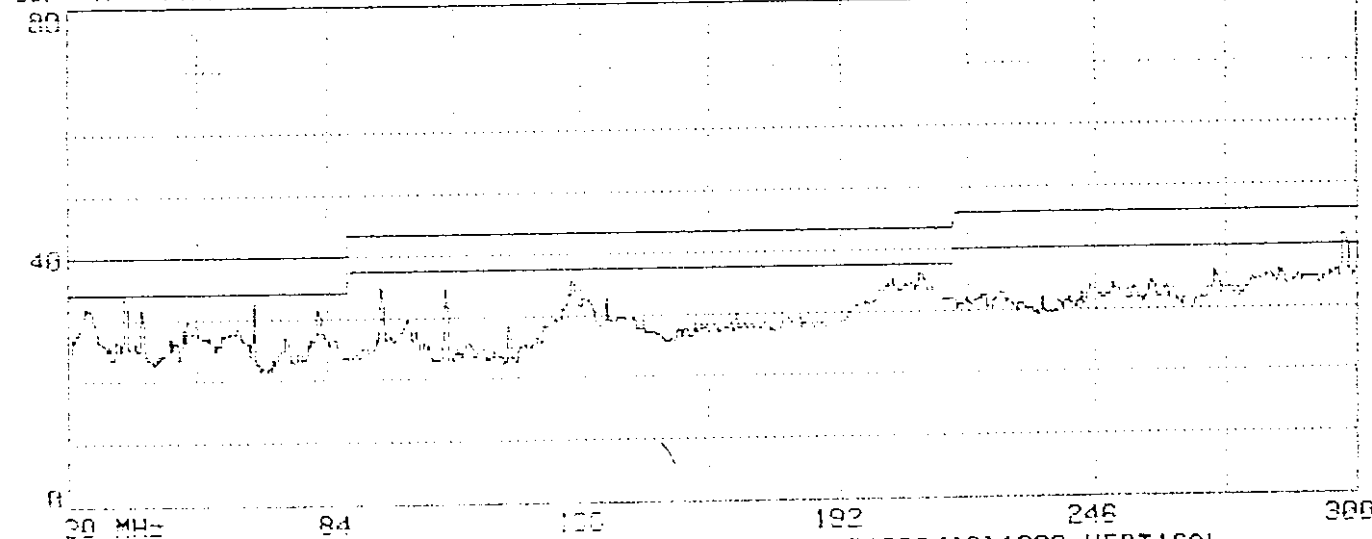

Limit : FCC CLASS-B 3m
 EUT : 17" MONITOR N/A:TX-D7S36NM
 Margin: 6dB Standard: 0
 Memo : 64KHz(1280X1024;60Hz)1.8m0-SUB CABLE
 Probe: 00A91050(A3)1223 VERTICAL
 Power: 120Vac/60Hz
 Trace: 2126, 0, 0, 0, 0

Page#: 2123 SP File#: MATSUSHI.E1
dBm/Hz ANECHOIC CHAMBER

Date: 84-01-1998 Time: 15:33:26
TAIWAN TOKIN EMC ENG. CORP.

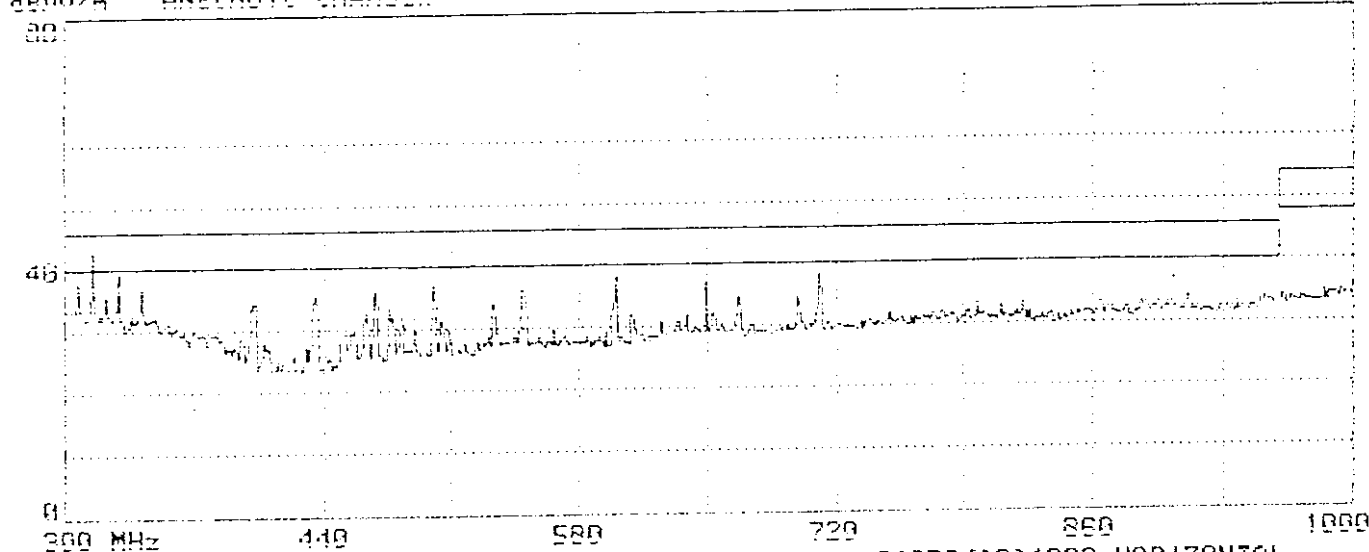

Limit : FCC CLASS-B 3m
EUT : 17" MONITOR N/N:TX-07336NM
Margin: 6dB Standard: 0
Memo : 64KHz (1280X1024;60Hz) 1.8mD-SUB CABLE
Probe: UHALP91079 (A3) 1223 HORIZONTAL
Power: 120Vac/60Hz
Trace: 2123, 0, 0, 0, 0

Page#: 2124 SP File#: MATSUSHI.E1
dBm/Hz ANECHOIC CHAMBER

Date: 84-01-1998 Time: 15:34:29
TAIWAN TOKIN EMC ENG. CORP.

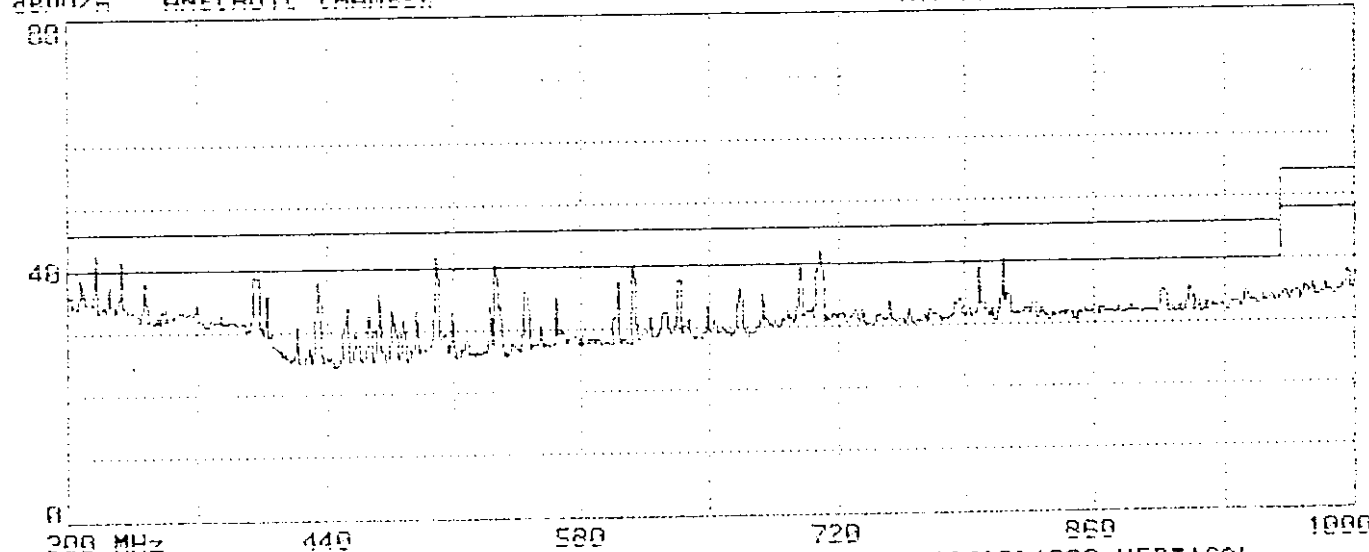

Limit : FCC CLASS-B 3m
EUT : 17" MONITOR N/N:TX-07336NM
Margin: 6dB Standard: 0
Memo : 64KHz (1280X1024;60Hz) 1.8mD-SUB CABLE
Probe: UHALP91079 (A3) 1223 VERTICAL
Power: 120Vac/60Hz
Trace: 2124, 0, 0, 0, 0

