



# FCC RADIO TEST REPORT

Applicant : ViewSonic Corporation  
Address : 10 Pointe Dr. Suite 200. Brea, CA 92821, USA  
Equipment : RF Module  
Model No. : VS17803  
Trade Name : ViewSonic  
FCC ID. : GSS-VS17337

**I HEREBY CERTIFY THAT :**

The sample was received on Apr. 24, 2019 and the testing was completed on June. 03, 2019 at CerpPASS Technology Corp. The test result refers exclusively to the test presented test model / sample. Without written approval of CerpPASS Technology Corp., the test report shall not be reproduced except in full.

Approved by:

Mark Liao / Supervisor

Laboratory Accreditation:

CerpPASS Technology Corporation Test Laboratory





Contents

- 1. **Summary of Test Procedure and Test Results**..... 5
  - 1.1 Applicable Standards ..... 5
- 2. **Test Configuration of Equipment under Test**..... 6
  - 2.1 Feature of Equipment..... 6
  - 2.2 Carrier Frequency of Channels ..... 7
  - 2.3 Test Mode and Test Software ..... 8
  - 2.4 Description of Test System..... 8
  - 2.5 General Information of Test..... 9
  - 2.6 Measurement Uncertainty ..... 10
- 3. **Test Equipment and Ancillaries Used for Tests** ..... 11
- 4. **Antenna Requirements**..... 12
  - 4.1 Antenna Construction and Directional Gain ..... 12
- 5. **Test of AC Power Line Conducted Emission** ..... 13
  - 5.1 Test Limit ..... 13
  - 5.2 Test Procedures ..... 13
  - 5.3 Typical Test Setup ..... 14
  - 5.4 Test Result and Data ..... 15
  - 5.5 Test Photographs ..... 17
- 6. **Test of Radiated Spurious Emission**..... 18
  - 6.1 Test Limit ..... 18
  - 6.2 Test Procedures ..... 18
  - 6.3 Typical Test Setup ..... 19
  - 6.4 Test Result and Data (9KHz ~ 30MHz) ..... 20
  - 6.5 Test Result and Data (30MHz ~ 1GHz)..... 20
  - 6.6 Test Result and Data (1GHz ~ 25GHz)..... 22
  - 6.7 Restricted Bands of Operation ..... 46
  - 6.8 Test Photographs (30MHz ~ 1GHz) ..... 47
  - 6.9 Test Photographs (1GHz ~ 25GHz) ..... 48
- 7. **Test of Conducted Spurious Emission** ..... 49
  - 7.1 Test Limit ..... 49
  - 7.2 Test Procedure ..... 49
  - 7.3 Test Setup Layout ..... 49
  - 7.4 Test Result and Data ..... 49
- 8. **On Time, Duty Cycle and Measurement methods** ..... 58
  - 8.1 Test Limit ..... 58
  - 8.2 Test Procedure ..... 58
  - 8.3 Test Setup Layout ..... 58
  - 8.4 Test Result and Data ..... 58
- 9. **6dB Bandwidth Measurement Data** ..... 60
  - 9.1 Test Limit ..... 60
  - 9.2 Test Procedures ..... 60
  - 9.3 Test Setup Layout ..... 60



9.4 Test Result and Data ..... 60

**10. Maximum Peak and Average Output Power ..... 63**

10.1 Test Limit ..... 63

10.2 Test Procedures ..... 63

10.3 Test Setup Layout ..... 63

10.4 Test Result and Data ..... 63

**11. Power Spectral Density ..... 65**

11.1 Test Limit ..... 65

11.2 Test Procedures ..... 65

11.3 Test Setup Layout ..... 65

11.4 Test Result and Data ..... 65

**12. Radio Frequency Exposure ..... 68**

12.1 Applicable Standards ..... 68

12.2 EUT Specification ..... 68

12.3 Test Results ..... 69

12.4 Calculation ..... 69

12.5 Maximum Permissible Exposure ..... 69



### History of this test report

Report No.	Issue Date	Description
TEF11904199	June. 06, 2019	Original



# 1. Summary of Test Procedure and Test Results

## 1.1 Applicable Standards

**ANSI C63.4:2014**

**ANSI C63.10:2013**

**FCC Rules and Regulations Part 15 Subpart C §15.247**

**KDB558074**

**KDB662911**

**KDB447498**

FCC Rule	Description of Test	Result
15.203	. Antenna Requirement	PASS
15.207	. AC Power Line Conducted Emission	PASS
15.209 15.205	. Radiated Spurious Emission	PASS
15.247(d)	. Conducted Spurious Emission	PASS
15.247(a)(2)	. 6dB Bandwidth	PASS
15.247(b)	. Maximum Peak and Average Output Power	PASS
15.247(e)	. Power Spectral Density	PASS
2.1091	. Radio Frequency Exposure	PASS

\*The principle of judgment is made according to the laboratory's reporting control and measurement uncertainty standard procedures.

\*This EUT has been also tested and compiled with the requirement of FCC Part 15, Subpart B, recorded in a separate test report(DEFD1801064).



## 2. Test Configuration of Equipment under Test

### 2.1 Feature of Equipment

Frequency Range	BT / BLE: 2400-2483.5MHz 802.11b/g/n/ac: 2400-2483.5MHz 802.11a/n/ac: 5150-5250MHz, 5725-5850MHz
Modulation Type	BT: GFSK, $\pi/4$ -DQPSK, 8DPSK BLE: GFSK 802.11b: CCK, DQPSK, DBPSK 802.11g/n/a: BPSK, QPSK, 16QAM, 64QAM 802.11ac: BPSK, QPSK, 16QAM, 64QAM, 256QAM
Modulation Technology	DSSS, OFDM, FHSS, DTS
Data Rate	BT: GFSK: 1Mbps, $\pi/4$ -DQPSK: 2Mbps, 8DPSK: 3Mbps BLE: GFSK: 1Mbps WLAN: 2.4GHz: 802.11b: 1, 2, 5.5, 11Mbps 802.11g: 6, 9, 12, 18, 24, 36, 48, 54Mbps 802.11n: MCS0 – MCS7, HT20/40 802.11ac: MCS0 – MCS9, VHT20/40 5GHz: 802.11a: 6, 9, 12, 18, 24, 36, 48, 54Mbps 802.11n: MCS0 – MCS7, HT20/40 802.11ac: MCS0 – MCS9, VHT20/40/80
Antenna Type	FPC Antenna
Antenna Gain	2400-2480MHz: 2.1dBi For BT/BLE For WLAN: 2400-2483.5MHz: 2.1dBi 5150-5250MHz: 2.2dBii 5725-5850MHz: 2.2dBi



### 2.2 Carrier Frequency of Channels

802.11b, 802.11g, 802.11n HT20, 802.11ac VHT20 (2412MHz~2462MHz)

Channel	Frequency(MHz)	Channel	Frequency(MHz)
<b>*01</b>	<b>2412</b>	07	2442
02	2417	08	2447
03	2422	09	2452
04	2427	10	2457
05	2432	<b>*11</b>	<b>2462</b>
<b>*06</b>	<b>2437</b>	---	---

802.11n HT40, 802.11ac VHT40 (2422MHz~2452MHz)

Channel	Frequency(MHz)	Channel	Frequency(MHz)
---	---	07	2442
---	---	08	2447
<b>*03</b>	<b>2422</b>	<b>*09</b>	<b>2452</b>
04	2427	---	---
05	2432	---	---
<b>*06</b>	<b>2437</b>	---	---

Note: Channels remarked \* are selected to perform test.



### 2.3 Test Mode and Test Software

- a. During testing, the interface cables and equipment positions were varied according to ANSI C63.10.
- b. The complete test system included Remote workstation and EUT for RF test. The Remote workstation included Notebook.
- c. An executive program, "RTL11ac\_8821CU\_USB:vw0.22\_20170519" under WIN 7 was executed to transmit and receive data via WLAN.
- d. The following test modes were performed for the test:

Conducted Emissions from the AC mains power ports	
Test Mode	Operating Description
1	802.11b (1Mbps)
2	802.11g (6Mbps)
3	VHT20 (6.5Mbps)
4	VHT40 (13.5Mbps)
caused "Test Mode 4" generated the worst case, it was reported as the final data.	
Radiation Emissions (30MHz ~ 1GHz)	
Test Mode	Operating Description
1	802.11b (1Mbps)
2	802.11g (6Mbps)
3	VHT20 (6.5Mbps)
4	VHT40 (13.5Mbps)
caused "Test Mode 4" generated the worst case, they were reported as the final data.	
Radiation Emissions (1GHz ~ 25GHz)	
Test Mode	Operating Description
1	802.11b (1Mbps)
2	802.11g (6Mbps)
3	VHT20 (6.5Mbps)
4	VHT40 (13.5Mbps)
caused "Test Mode 1~4" generated the worst case, they were reported as the final data.	

### 2.4 Description of Test System

RF Conducted				
Equipment	Brand	Model	Length/Type	Power cord/Length/Type
Notebook	ASUS	P2430U	N/A	Adapter / 1.8m / NS
Radiated Emissions				
Equipment	Brand	Model	Length/Type	Power cord/Length/Type
Notebook	ASUS	P2430U	N/A	Adapter / 1.8m / NS
AC Power Line Conducted Emission				
Equipment	Brand	Model	Length/Type	Power cord/Length/Type
Notebook	DELL	Latitude E5470	N/A	Adapter / 1.8m / NS



**2.5 General Information of Test**

Test Site	<b>CerpPASS Technology Corporation Test Laboratory</b> Address: No.10, Ln. 2, Lianfu St., Luzhu Dist., Taoyuan City 33848, Taiwan (R.O.C.) Tel:+886-3-3226-888 Fax:+886-3-3226-881 Address: No.68-1, Shihbachongsi, Shihding Township, New Taipei City 223, Taiwan, R.O.C. Tel: +886-2-2663-8582	
	FCC	TW1079, TW1061, TW1439
	IC	4934E-1, 4934E-2
	VCCI	T-2205 for Telecommunication test C-4663 for Conducted emission test R-4399, R-4218 for Radiated emission test G-10812, G-10813 for radiated disturbance above 1GHz
Frequency Range Investigated:	Conducted: from 150kHz to 30 MHz Radiation: from 30 MHz to 25,000MHz	
Test Distance:	The test distance of radiated emission from antenna to EUT is 3 M.	

Test Item	Test Site	Tested Date	Environmental Conditions	Tested By
RF Conducted	RFCON01-NK	2019/06/03	24°C / 61%	Vic Yeh
Radiated Emissions	3M02-NK	2019/05/29	22°C / 53%	Spree Yeh
RF Conduction	CON01-NK	2019/05/31	22°C / 43%	Spree Yeh



### 2.6 Measurement Uncertainty

Measurement Item	Uncertainty
Radiated Spurious Emission(9KHz~30MHz)	±3.405dB
Radiated Spurious Emission(30MHz~1GHz)	±5.326dB
Radiated Spurious Emission(1GHz~25GHz)	±5.918dB
Conducted Spurious Emission	±2.156dB
6dB Bandwidth	±4.401%
20dB Bandwidth	±4.40%
Occupied Bandwidth	±4.41%
Peak Output Power(Conducted Power Meter)	±1.31dB
Dwell Time	±0.11%
Power Spectral Density	±2.146dB
Duty Cycle	±0.17%



### 3. Test Equipment and Ancillaries Used for Tests

Test Item	Radiated Emissions				
Test Site	Semi Anechoic Room(3M02-NK)				
Instrument	Manufacturer	Model No	Serial No	Calibration Date	Valid Date
Bilog Antenna	Schwarzbeck	VULB9168	275	2018/09/17	2019/09/16
Active Loop Antenna	EMCO	6507	40855	2019/05/24	2020/05/23
Horn Antenna	EMCO	3115	31589	2019/04/01	2020/03/31
Horn Anrenna	EMCO	3116	31974	2018/09/07	2019/09/06
EMI Receiver	ROHDE & SCHWARZ	ESCI	101423	2018/06/11	2019/06/10
Spectrum Analyzer	ROHDE & SCHWARZ	FSP 40	100219	2018/07/03	2019/07/02
Preamplifier	EM Electronics corp.	EM330	60660	2019/03/11	2020/03/10
Preamplifier	EMC INSTRUMENTS	EMC051845SE	980333	2018/09/18	2019/09/17
Bluetooth Tester	ROHDE & SCHWARZ	CBT	101133	2019/04/07	2020/04/06
Cable-3in1(30M-1G)	HARBOUR INDUSTRIES	LL142	CCE1316	2018/09/12	2019/09/11
Cable-0.5m(1G-40G)	Rapidtek	40GHZ 50CM	38MS-38MS50314	2019/04/09	2020/04/08
Cable-3m(1G-40G)	Rapidtek	40GHZ 300CM	38MS-38MS300314	2019/04/09	2020/04/08
Cable-8m(1G-40G)	Rapidtek	40GHZ 800CM	38MS-38MS800314	2019/04/10	2020/04/09
E3	AUDIX	v8.2014-8-6	RK-000529	NA	NA

Test Item	RF Conducted				
Test Site	RFCON01-NK				
Instrument	Manufacturer	Model No	Serial No	Calibration Date	Valid Date
Spectrum Analyzer	ROHDE & SCHWARZ	FSP 40	100219	2018/07/03	2019/07/02
Bluetooth Tester	ROHDE & SCHWARZ	CBT	101133	2019/04/07	2020/04/06
Attenuator	KEYSIGHT	8491B	MY39250705	2018/09/04	2019/09/03
TEMP & HUMI CHAMBER	T-MACHINE	TMJ-9712	T-12-040111	2018/08/30	2019/08/29
Power Sensor	Anritsu	MA2411B	1207295	2019/04/11	2020/04/10

Test Item	AC Power Line Conducted Emission				
Test Site	CON01-NK				
Instrument	Manufacturer	Model No	Serial No	Calibration Date	Valid Date
EMI Receiver	ROHDE & SCHWARZ	ESCI	100821	2018/9/12	2019/09/11
Line Impedance Stabilization Network	Schwarzbeck	NSLK 8127	8127-740	2018/6/13	2019/06/12
Pulse Limiter	ROHDE & SCHWARZ	ESH3-Z2	101933	2018/9/4	2019/09/03
E3	AUDIX	v8.2014-8-6	RK-000531	NA	NA



## 4. Antenna Requirements

### 4.1 Antenna Construction and Directional Gain

Antenna Type	FPC Antenna
Antenna Gain	2400-2483.5MHz: 2.1dBi 5150MHz-5250MHz: 2.2dBi 5725MHz -5850MHz: 2.2dBi

2400-2483.5MHz
For Power directional gain= $G_{ant}= 2.1$ dBi For PSD directional gain = $G_{ant}= 2.1$ dBi
5150MHz -5250MHz
For Power directional gain= $G_{ant}= 2.2$ dBi For PSD directional gain = $G_{ant}= 2.2$ dBi
5725MHz -5850MHz
For Power directional gain= $G_{ant}= 2.2$ dBi For PSD directional gain = $G_{ant}= 2.2$ dBi



## 5. Test of AC Power Line Conducted Emission

### 5.1 Test Limit

Conducted Emissions were measured from 150 kHz to 30 MHz with a bandwidth of 9 KHz, according to the methods defined in ANSI C63.4-2014. The EUT was placed on a nonmetallic stand in a shielded room 0.8 meters above the ground plane. The interface cables and equipment positioning were varied within limits of reasonable applications to determine the position produced maximum conducted emissions.

Frequency (MHz)	Quasi Peak (dB $\mu$ V)	Average (dB $\mu$ V)
0.15 – 0.5	66-56*	56-46*
0.5 – 5.0	56	46
5.0 – 30.0	60	50

\*Decreases with the logarithm of the frequency.

### 5.2 Test Procedures

- a. The EUT was placed 0.4 meter from the conducting wall of the shielding room was kept at least 80 centimeters from any other grounded conducting surface.
- b. Connect EUT to the power mains through a line impedance stabilization network (LISN).
- c. All the support units are connecting to the other LISN.
- d. The LISN provides 50 ohm coupling impedance for the measuring instrument.
- e. The FCC states that a 50 ohm, 50 micro-Henry LISN should be used.
- f. Both sides of AC line were checked for maximum conducted interference.
- g. The frequency range from 150 kHz to 30 MHz was searched.
- h. Set the test-receiver system to Peak Detect Function and Specified Bandwidth with Maximum Hold Mode.



### 5.3 Typical Test Setup

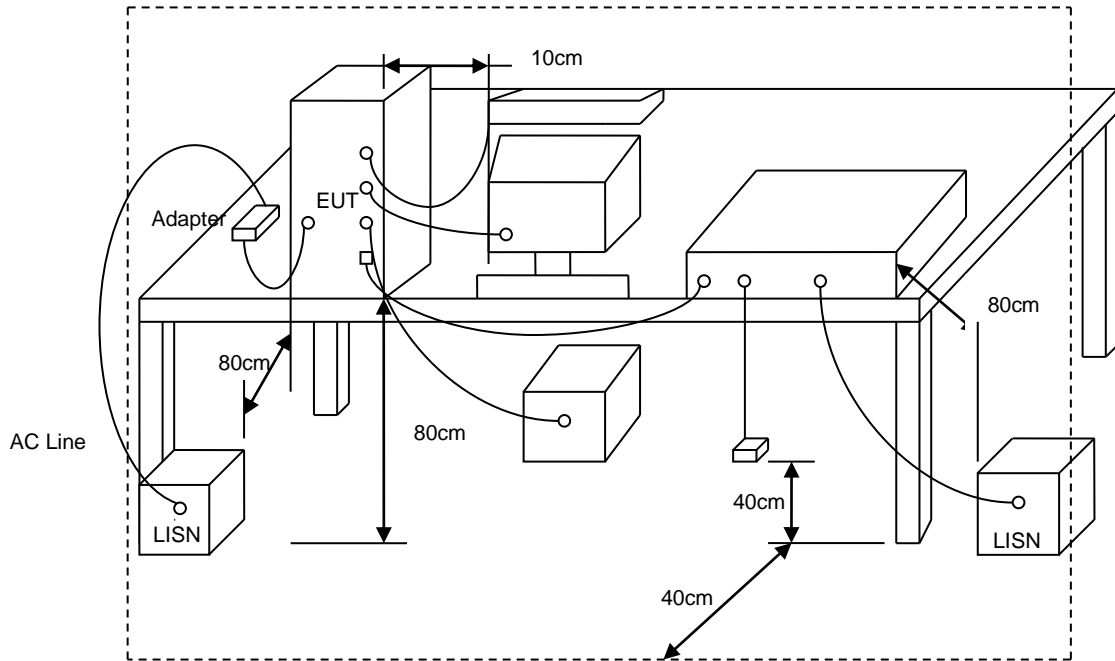



5.4 Test Result and Data

Power	: DC 5V from system	Pol/Phase	: LINE
Test Mode	: Mode 4		:

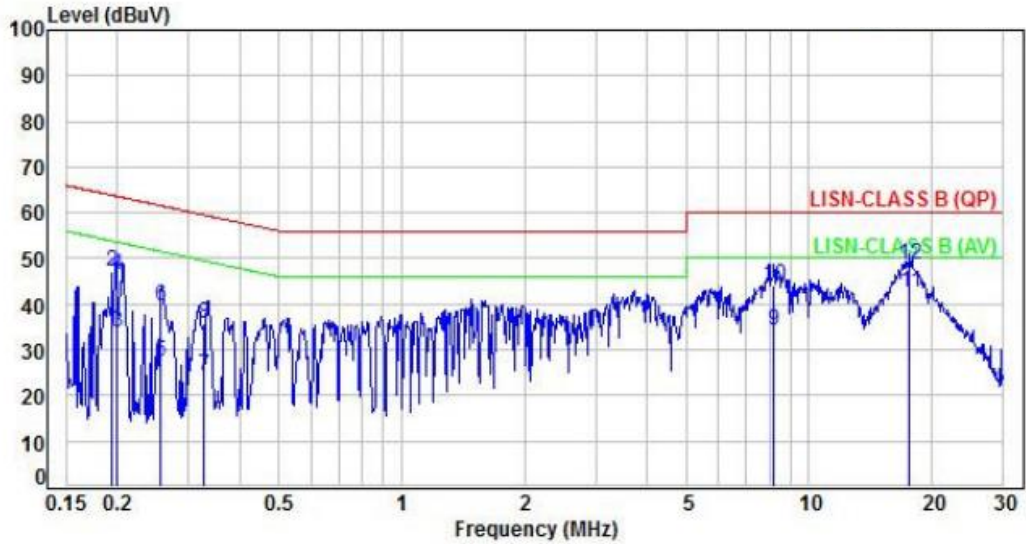

No.	Frequency (MHz)	Factor (dB)	Reading (dBuV)	Level (dBuV)	Limit (dBuV)	Margin (dB)	Detector	P/F
1	0.19	9.92	24.57	34.49	53.82	-19.33	Average	P
2	0.19	9.92	37.12	47.04	63.82	-16.78	QP	P
3	0.20	9.92	24.01	33.93	53.58	-19.65	Average	P
4	0.20	9.92	36.56	46.48	63.58	-17.10	QP	P
5	0.25	9.92	17.51	27.43	51.61	-24.18	Average	P
6	0.25	9.92	29.63	39.55	61.61	-22.06	QP	P
7	0.33	9.94	14.30	24.24	49.55	-25.31	Average	P
8	0.33	9.94	25.97	35.91	59.55	-23.64	QP	P
9	8.20	10.22	23.95	34.17	50.00	-15.83	Average	P
10	8.20	10.22	33.92	44.14	60.00	-15.86	QP	P
11	17.65	10.54	31.94	42.48	50.00	-7.52	Average	P
12	17.65	10.54	38.17	48.71	60.00	-11.29	QP	P

Note: Level=Reading+Factor  
 Margin=Level-Limit  
 Factor=(LISN or ISN or Current Probe)Factor + Cable Loss



Power	: DC 5V from system	Pol/Phase	: NEUTRAL
Test Mode	: Mode 4		

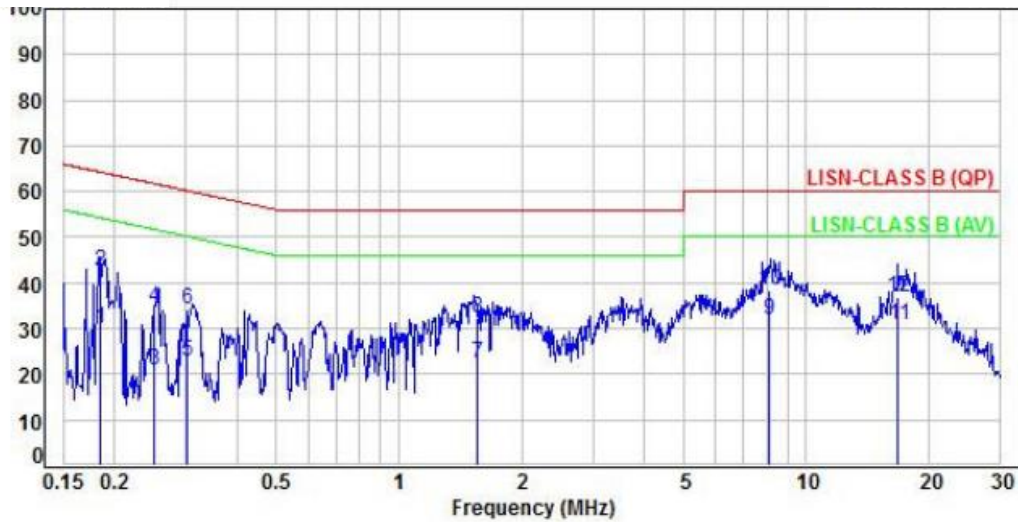

No.	Frequency (MHz)	Factor (dB)	Reading (dBuV)	Level (dBuV)	Limit (dBuV)	Margin (dB)	Detector	P/F
1	0.19	9.95	20.09	30.04	54.25	-24.21	Average	P
2	0.19	9.95	32.64	42.59	64.25	-21.66	QP	P
3	0.25	9.95	10.96	20.91	51.73	-30.82	Average	P
4	0.25	9.95	24.53	34.48	61.73	-27.25	QP	P
5	0.30	9.95	12.95	22.90	50.17	-27.27	Average	P
6	0.30	9.95	24.34	34.29	60.17	-25.88	QP	P
7	1.56	10.00	12.26	22.26	46.00	-23.74	Average	P
8	1.56	10.00	22.13	32.13	56.00	-23.87	QP	P
9	8.13	10.24	21.81	32.05	50.00	-17.95	Average	P
10	8.13	10.24	28.35	38.59	60.00	-21.41	QP	P
11	16.81	10.55	20.19	30.74	50.00	-19.26	Average	P
12	16.81	10.55	26.25	36.80	60.00	-23.20	QP	P

Note: Level=Reading+Factor  
 Margin=Level-Limit  
 Factor=(LISN or ISN or Current Probe)Factor + Cable Loss





## 6. Test of Radiated Spurious Emission

### 6.1 Test Limit

In any 100kHz bandwidth outside the frequency band in which the spread spectrum or digitally modulated intentional radiator is operating, the radio frequency power that is produced by the intentional radiator shall be at least 20dB below that in the 100kHz bandwidth within the band that contains the highest level of the desired power, based on either an RF conducted or a radiated measurement. If the transmitter measurement is based on the maximum conducted output power, the attenuation required under this paragraph shall be 30dB instead of 20dB. In addition, radiated emissions which fall in section 15.205(a) the restricted bands must also comply with the radiated emission limit specified in section 15.209(a).

Frequency (MHz)	Field Strength (microvolt/meter)	Measurement Distance (meters)
0.009 ~ 0.490	2400/F(kHz)	300
0.490 ~ 1.705	24000/F(kHz)	30
1.705 ~ 30.0	30	30
30 ~ 88	100	3
88 ~ 216	150	3
216 ~ 960	200	3
Above 960	500	3

### 6.2 Test Procedures

- The EUT was placed on a rotatable table top 0.8 meter above ground.
- The EUT was set 3 meters from the interference receiving antenna which was mounted on the top of a variable height antenna tower.
- The table was rotated 360 degrees to determine the position of the highest radiation.
- The antenna is a broadband antenna and its height is varied between one meter and four meters above ground to find the maximum value of the field strength both horizontal polarization and vertical polarization of the antenna are set to make the measurement.
- For each suspected emission the EUT was arranged to its worst case and then tune the antenna tower (from 1 M to 4 M) and turn table (from 0 degree to 360 degrees) to find the maximum reading.
- Set the test-receiver system to Peak or CISPR quasi-peak Detect Function and specified bandwidth with Maximum Hold Mode.
- If the emission level of the EUT in peak mode was 3 dB lower than the limit specified, then testing will be stopped and peak values of EUT will be reported, otherwise, the emissions which do not have 3 dB margin will be repeated one by one using the quasi-peak method and reported.
- For testing above 1GHz, the emission level of the EUT in peak mode was 20dB lower than average limit (that means the emission level in peak mode also complies with the limit in average mode), then testing will be stopped and peak values of EUT will be reported, otherwise, the emissions will be measured in average mode again and reported.
- "Cone of radiation" has been considered to be 3dB bandwidth of the measurement antenna.



### 6.3 Typical Test Setup

Below 30MHz test setup

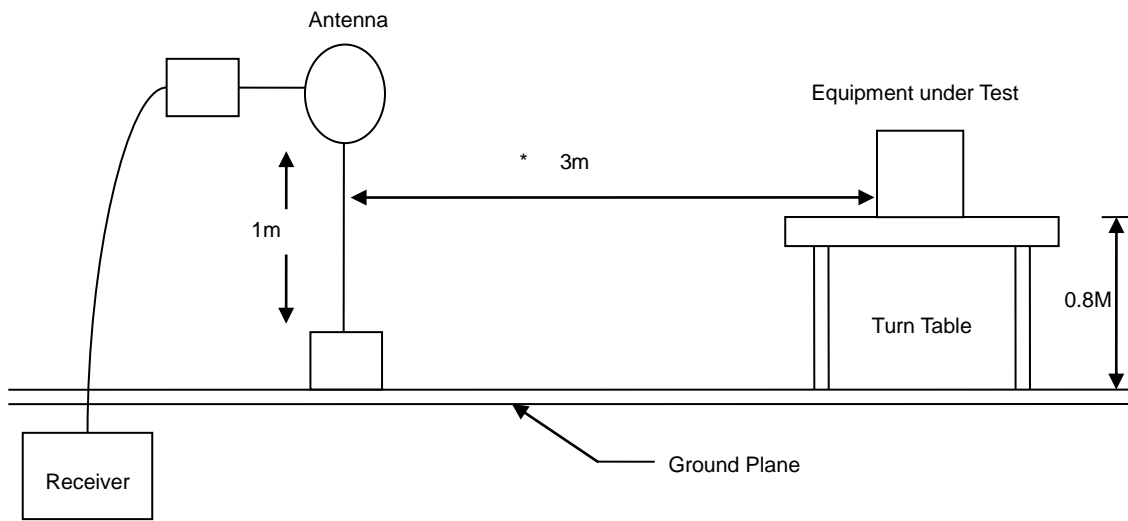

30MHz- 1GHz Test Setup

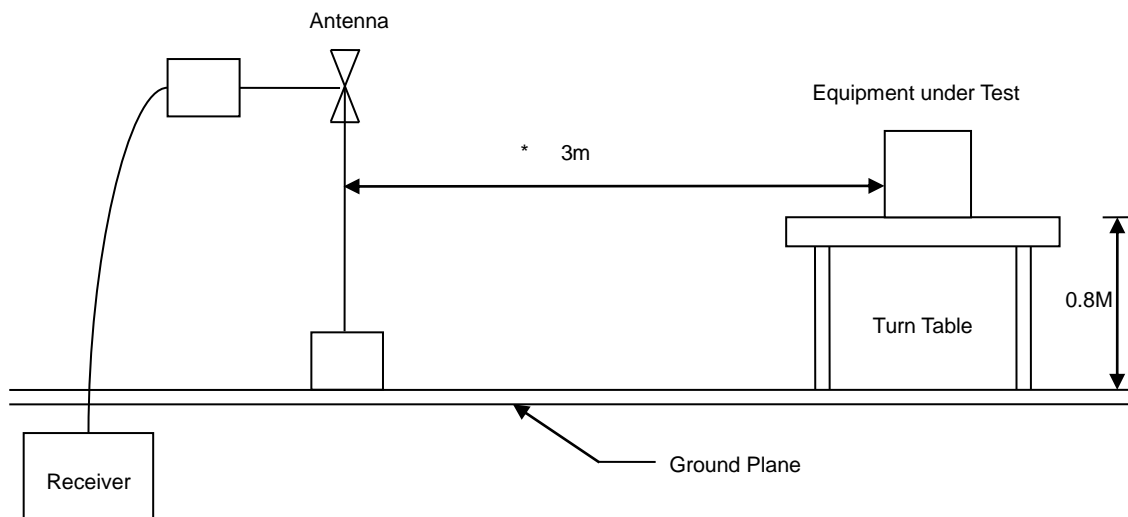

Above 1GHz Test Setup

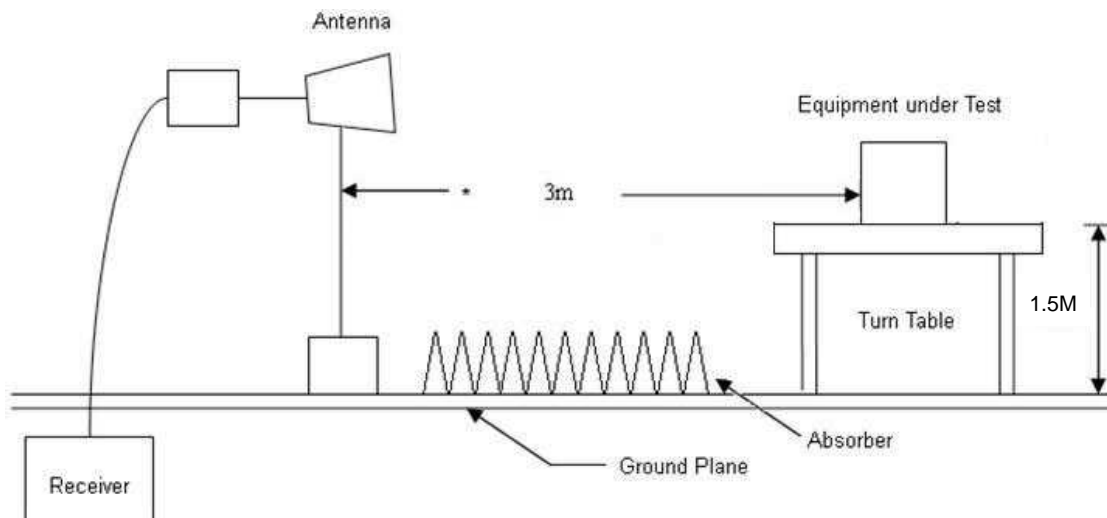



### 6.4 Test Result and Data (9KHz ~ 30MHz)

The 9kHz - 30MHz spurious emission is under limit 20dB more.

### 6.5 Test Result and Data (30MHz ~ 1GHz)

Power	: DC 5V from system	Pol/Phase	: VERTICAL
Test Mode	: Mode 4		:

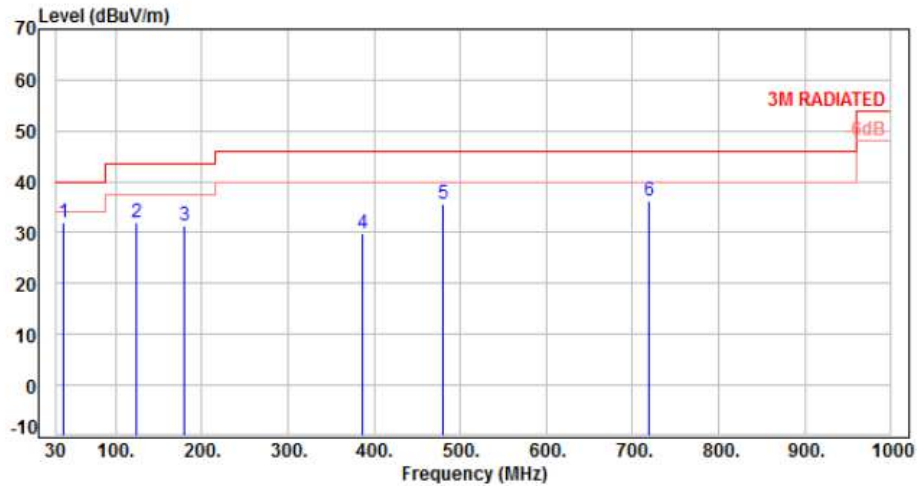

No.	Frequency (MHz)	Factor (dB)	Reading (dBuV)	Level (dBuV/m)	Limit (dBuV/m)	Margin (dB)	Detector	Height (cm)	Azimuth (deg)	P/F
1	38.73	-9.81	41.92	32.11	40.00	-7.89	Peak	400	0	P
2	123.12	-11.54	43.63	32.09	43.50	-11.41	Peak	400	0	P
3	179.38	-10.85	42.36	31.51	43.50	-11.99	Peak	400	0	P
4	386.96	-6.24	36.22	29.98	46.00	-16.02	Peak	400	0	P
5	480.08	-4.28	39.98	35.70	46.00	-10.30	Peak	400	0	P
6	719.67	0.00	36.37	36.37	46.00	-9.63	Peak	400	0	P

Note: Level=Reading+Factor  
Margin=Level-Limit  
Factor=Antenna Factor + cable loss - Amplifier Factor



Power	: DC 5V from system	Pol/Phase	: HORIZONTAL
Test Mode	: Mode 4		:

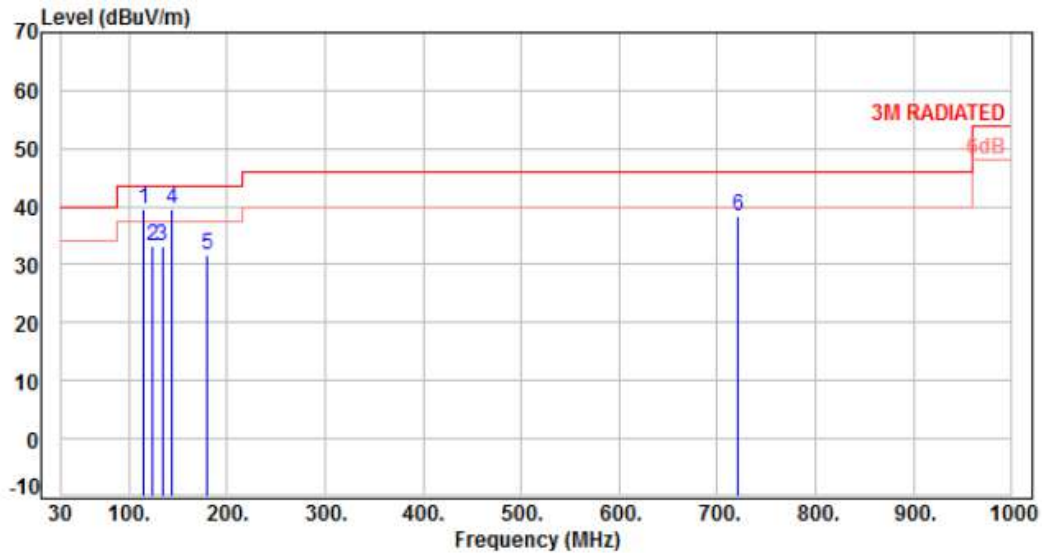

No.	Frequency (MHz)	Factor (dB)	Reading (dBuV)	Level (dBuV/m)	Limit (dBuV/m)	Margin (dB)	Detector	Height (cm)	Azimuth (deg)	P/F
1	115.36	-12.32	51.84	39.52	43.50	-3.98	Peak	100	0	P
2	123.12	-11.54	44.70	33.16	43.50	-10.34	QP	164	13	P
3	133.79	-10.46	43.60	33.14	43.50	-10.36	QP	171	20	P
4	144.46	-9.71	49.42	39.71	43.50	-3.79	Peak	100	0	P
5	179.38	-10.85	42.63	31.78	43.50	-11.72	QP	152	311	P
6	721.61	0.02	38.43	38.45	46.00	-7.55	Peak	100	0	P

Note: Level=Reading+Factor  
Margin=Level-Limit  
Factor=Antenna Factor + cable loss - Amplifier Factor



### 6.6 Test Result and Data (1GHz ~ 25GHz)

Power	: DC 5V from system	Pol/Phase	: VERTICAL
Test Mode	: Mode 1, CH01		:

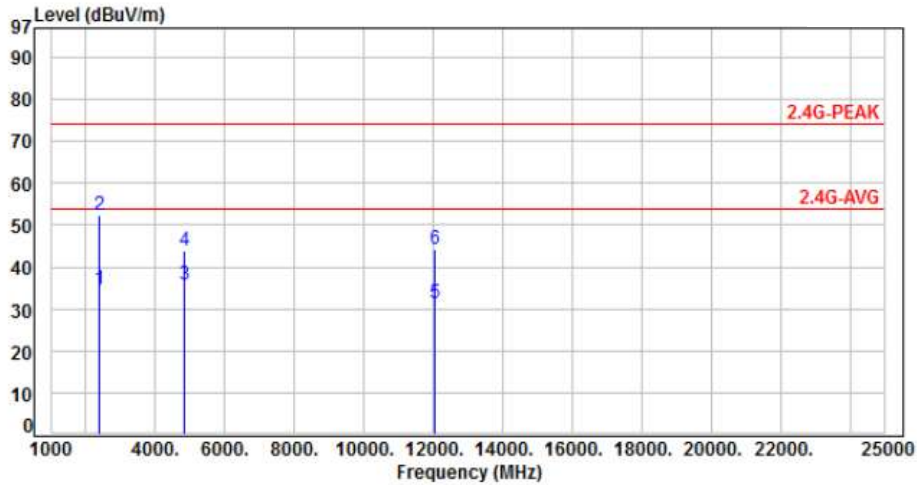

No.	Frequency (MHz)	Factor (dB)	Reading (dBuV)	Level (dBuV/m)	Limit (dBuV/m)	Margin (dB)	Detector	Height (cm)	Azimuth (deg)	P/F
1	2390.00	-14.61	49.10	34.49	54.00	-19.51	Average	130	145	P
2	2390.00	-14.61	66.80	52.19	74.00	-21.81	Peak	130	145	P
3	4824.00	-6.82	42.60	35.78	54.00	-18.22	Average	351	21	P
4	4824.00	-6.82	50.80	43.98	74.00	-30.02	Peak	351	21	P
5	12060.00	4.61	26.77	31.38	54.00	-22.62	Average	100	59	P
6	12060.00	4.61	39.58	44.19	74.00	-29.81	Peak	100	59	P

Note: Level=Reading+Factor  
Margin=Level-Limit  
Factor=Antenna Factor + cable loss - Amplifier Factor



Power	: DC 5V from system	Pol/Phase	: HORIZONTAL
Test Mode	: Mode 1, CH01		:

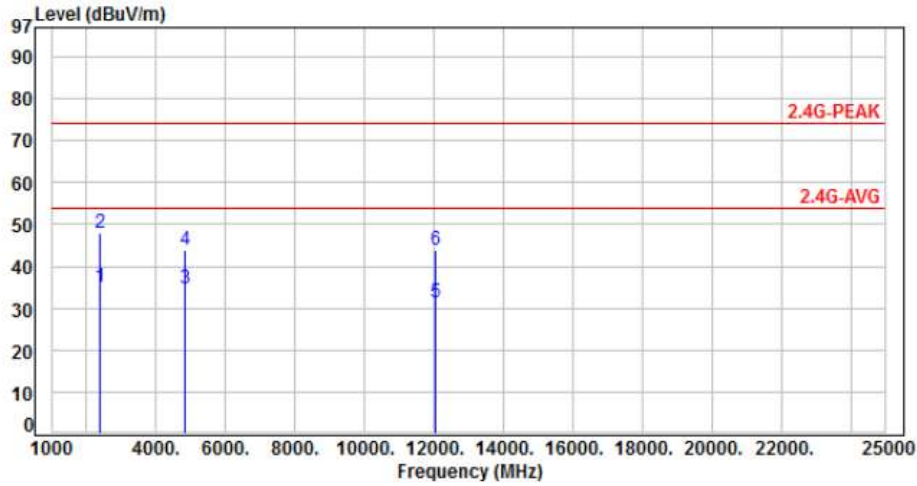

No.	Frequency (MHz)	Factor (dB)	Reading (dBuV)	Level (dBuV/m)	Limit (dBuV/m)	Margin (dB)	Detector	Height (cm)	Azimuth (deg)	P/F
1	2390.00	-14.61	49.51	34.90	54.00	-19.10	Average	386	12	P
2	2390.00	-14.61	62.71	48.10	74.00	-25.90	Peak	386	12	P
3	4824.00	-6.82	41.50	34.68	54.00	-19.32	Average	330	330	P
4	4824.00	-6.82	50.80	43.98	74.00	-30.02	Peak	330	330	P
5	12060.00	4.61	26.77	31.38	54.00	-22.62	Average	100	325	P
6	12060.00	4.61	39.45	44.06	74.00	-29.94	Peak	100	325	P

Note: Level=Reading+Factor  
 Margin=Level-Limit  
 Factor=Antenna Factor + cable loss - Amplifier Factor



Power	: DC 5V from system	Pol/Phase	: VERTICAL
Test Mode	: Mode 1, CH06		:

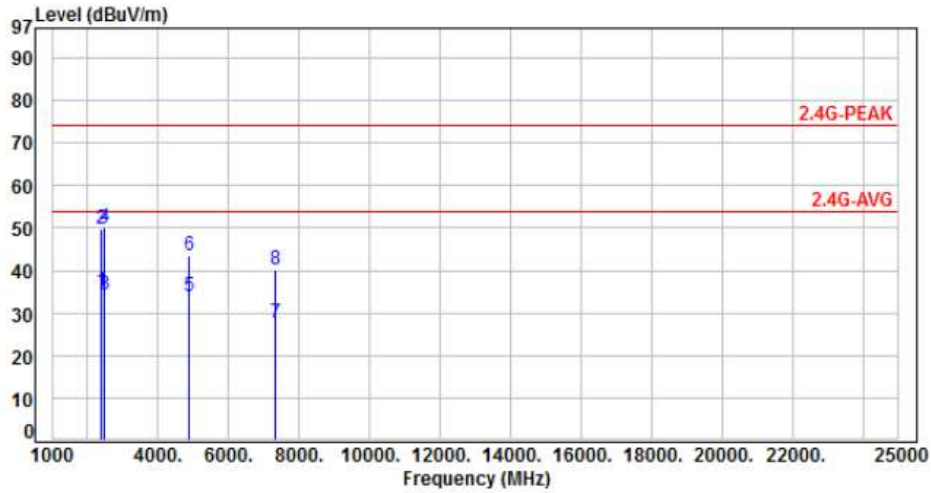

No.	Frequency (MHz)	Factor (dB)	Reading (dBuV)	Level (dBuV/m)	Limit (dBuV/m)	Margin (dB)	Detector	Height (cm)	Azimuth (deg)	P/F
1	2390.00	-14.61	49.71	35.10	54.00	-18.90	Average	145	163	P
2	2390.00	-14.61	64.23	49.62	74.00	-24.38	Peak	145	163	P
3	2483.50	-14.22	48.70	34.48	54.00	-19.52	Average	145	163	P
4	2483.50	-14.22	64.50	50.28	74.00	-23.72	Peak	145	163	P
5	4874.00	-6.63	40.50	33.87	54.00	-20.13	Average	347	25	P
6	4874.00	-6.63	50.10	43.47	74.00	-30.53	Peak	347	25	P
7	7311.00	-1.28	29.12	27.84	54.00	-26.16	Average	100	92	P
8	7311.00	-1.28	41.33	40.05	74.00	-33.95	Peak	100	92	P

Note: Level=Reading+Factor  
 Margin=Level-Limit  
 Factor=Antenna Factor + cable loss - Amplifier Factor





Power	: DC 5V from system	Pol/Phase	: HORIZONTAL
Test Mode	: Mode 1, CH06		:

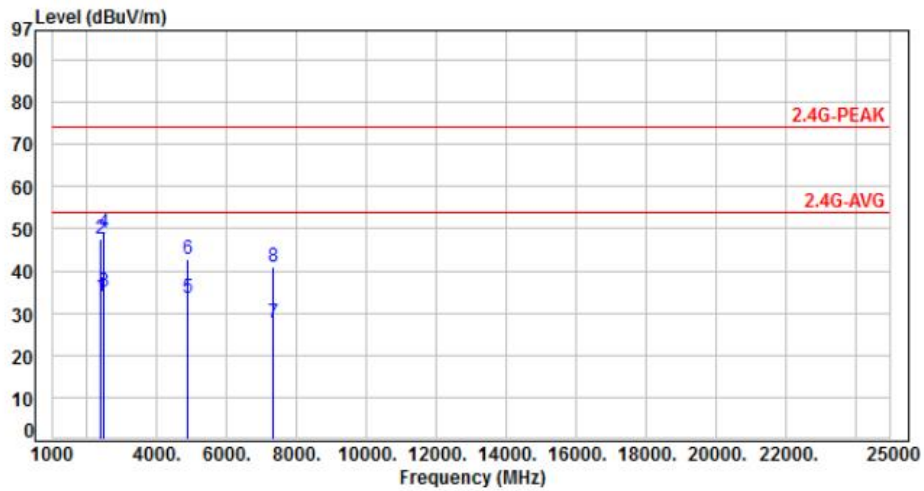

No.	Frequency (MHz)	Factor (dB)	Reading (dBuV)	Level (dBuV/m)	Limit (dBuV/m)	Margin (dB)	Detector	Height (cm)	Azimuth (deg)	P/F
1	2390.00	-14.61	48.67	34.06	54.00	-19.94	Average	335	341	P
2	2390.00	-14.61	62.30	47.69	74.00	-26.31	Peak	335	341	P
3	2483.50	-14.22	49.23	35.01	54.00	-18.99	Average	335	341	P
4	2483.50	-14.22	63.11	48.89	74.00	-25.11	Peak	335	341	P
5	4874.00	-6.63	40.30	33.67	54.00	-20.33	Average	347	329	P
6	4874.00	-6.63	49.60	42.97	74.00	-31.03	Peak	347	329	P
7	7311.00	-1.28	28.96	27.68	54.00	-26.32	Average	100	318	P
8	7311.00	-1.28	42.40	41.12	74.00	-32.88	Peak	100	318	P

Note: Level=Reading+Factor  
 Margin=Level-Limit  
 Factor=Antenna Factor + cable loss - Amplifier Factor





Power	: DC 5V from system	Pol/Phase	: VERTICAL
Test Mode	: Mode 1, CH11		:

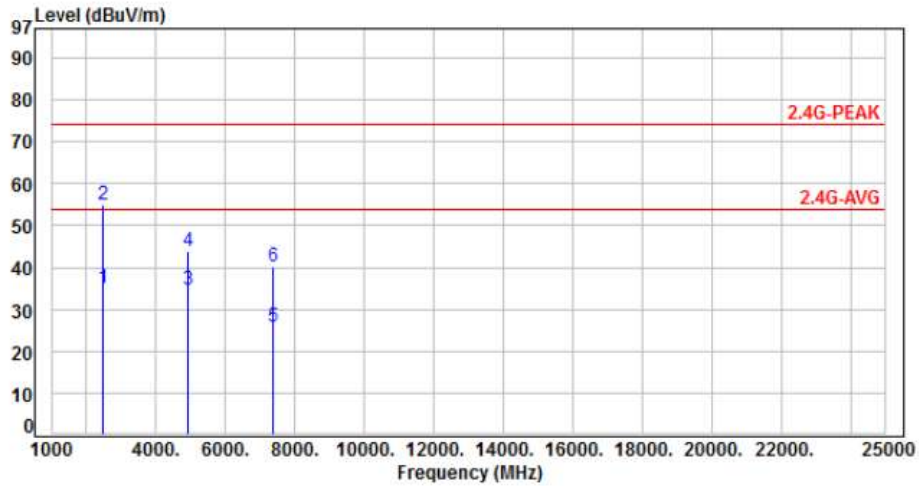

No.	Frequency (MHz)	Factor (dB)	Reading (dBuV)	Level (dBuV/m)	Limit (dBuV/m)	Margin (dB)	Detector	Height (cm)	Azimuth (deg)	P/F
1	2483.50	-14.22	49.36	35.14	54.00	-18.86	Average	115	144	P
2	2483.50	-14.22	69.20	54.98	74.00	-19.02	Peak	115	144	P
3	4924.00	-6.50	41.30	34.80	54.00	-19.20	Average	182	10	P
4	4924.00	-6.50	50.50	44.00	74.00	-30.00	Peak	182	10	P
5	7386.00	-1.19	27.12	25.93	54.00	-28.07	Average	100	95	P
6	7386.00	-1.19	41.51	40.32	74.00	-33.68	Peak	100	95	P

Note: Level=Reading+Factor  
Margin=Level-Limit  
Factor=Antenna Factor + cable loss - Amplifier Factor



Power	: DC 5V from system	Pol/Phase	: HORIZONTAL
Test Mode	: Mode 1, CH11		:

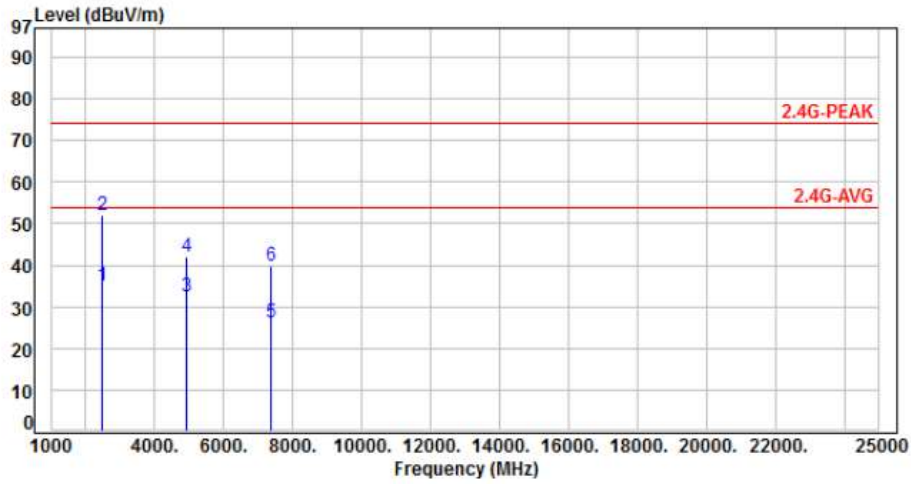

No.	Frequency (MHz)	Factor (dB)	Reading (dBUV)	Level (dBUV/m)	Limit (dBUV/m)	Margin (dB)	Detector	Height (cm)	Azimuth (deg)	P/F
1	2483.50	-14.22	49.10	34.88	54.00	-19.12	Average	364	360	P
2	2483.50	-14.22	66.35	52.13	74.00	-21.87	Peak	364	360	P
3	4924.00	-6.50	38.80	32.30	54.00	-21.70	Average	320	330	P
4	4924.00	-6.50	48.60	42.10	74.00	-31.90	Peak	320	330	P
5	7386.00	-1.19	27.24	26.05	54.00	-27.95	Average	100	321	P
6	7386.00	-1.19	40.86	39.67	74.00	-34.33	Peak	100	321	P

Note: Level=Reading+Factor  
 Margin=Level-Limit  
 Factor=Antenna Factor + cable loss - Amplifier Factor



Power	: DC 5V from system	Pol/Phase	: VERTICAL
Test Mode	: Mode 2, CH01		:

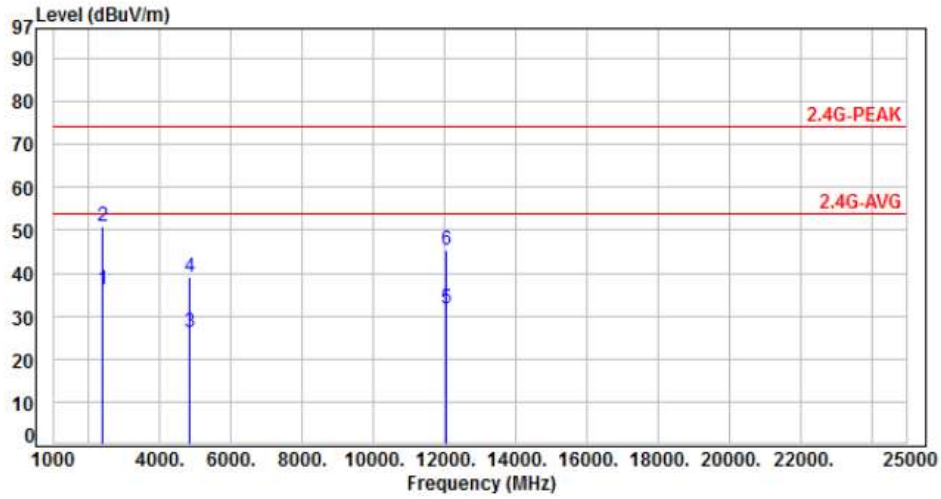

No.	Frequency (MHz)	Factor (dB)	Reading (dBuV)	Level (dBuV/m)	Limit (dBuV/m)	Margin (dB)	Detector	Height (cm)	Azimuth (deg)	P/F
1	2390.00	-14.61	50.91	36.30	54.00	-17.70	Average	133	145	P
2	2390.00	-14.61	65.60	50.99	74.00	-23.01	Peak	133	145	P
3	4824.00	-6.82	32.90	26.08	54.00	-27.92	Average	145	22	P
4	4824.00	-6.82	46.10	39.28	74.00	-34.72	Peak	145	22	P
5	12060.00	4.61	27.03	31.64	54.00	-22.36	Average	100	102	P
6	12060.00	4.61	40.60	45.21	74.00	-28.79	Peak	100	102	P

Note: Level=Reading+Factor  
 Margin=Level-Limit  
 Factor=Antenna Factor + cable loss - Amplifier Factor



Power	: DC 5V from system	Pol/Phase	: HORIZONTAL
Test Mode	: Mode 2, CH01		:

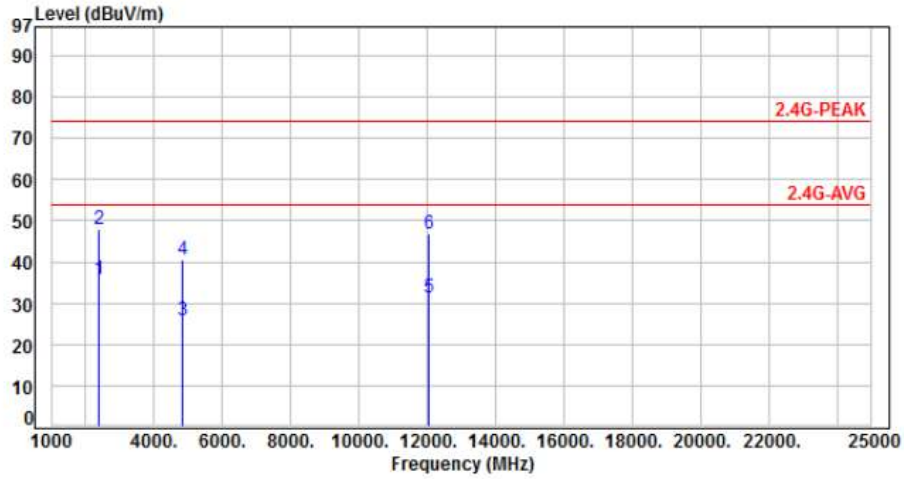

No.	Frequency (MHz)	Factor (dB)	Reading (dBuV)	Level (dBuV/m)	Limit (dBuV/m)	Margin (dB)	Detector	Height (cm)	Azimuth (deg)	P/F
1	2390.00	-14.61	50.30	35.69	54.00	-18.31	Average	377	150	P
2	2390.00	-14.61	62.41	47.80	74.00	-26.20	Peak	377	150	P
3	4824.00	-6.82	32.55	25.73	54.00	-28.27	Average	100	311	P
4	4824.00	-6.82	47.40	40.58	74.00	-33.42	Peak	100	311	P
5	12060.00	4.61	26.85	31.46	54.00	-22.54	Average	100	357	P
6	12060.00	4.61	42.12	46.73	74.00	-27.27	Peak	100	357	P

Note: Level=Reading+Factor  
 Margin=Level-Limit  
 Factor=Antenna Factor + cable loss - Amplifier Factor



Power	: DC 5V from system	Pol/Phase	: VERTICAL
Test Mode	: Mode 2, CH06		:

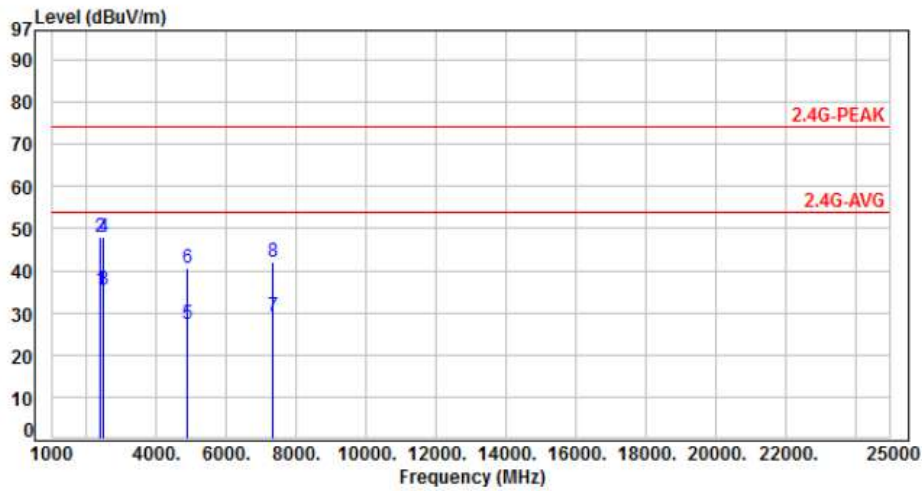

No.	Frequency (MHz)	Factor (dB)	Reading (dBuV)	Level (dBuV/m)	Limit (dBuV/m)	Margin (dB)	Detector	Height (cm)	Azimuth (deg)	P/F
1	2390.00	-14.61	49.89	35.28	54.00	-18.72	Average	138	150	P
2	2390.00	-14.61	62.48	47.87	74.00	-26.13	Peak	138	150	P
3	2483.50	-14.22	49.73	35.51	54.00	-18.49	Average	138	150	P
4	2483.50	-14.22	62.22	48.00	74.00	-26.00	Peak	138	150	P
5	4874.00	-6.63	34.10	27.47	54.00	-26.53	Average	106	92	P
6	4874.00	-6.63	47.23	40.60	74.00	-33.40	Peak	106	92	P
7	7311.00	-1.28	30.33	29.05	54.00	-24.95	Average	100	73	P
8	7311.00	-1.28	43.25	41.97	74.00	-32.03	Peak	100	73	P

Note: Level=Reading+Factor  
 Margin=Level-Limit  
 Factor=Antenna Factor + cable loss - Amplifier Factor



Power	: DC 5V from system	Pol/Phase	: HORIZONTAL
Test Mode	: Mode 2, CH06		:

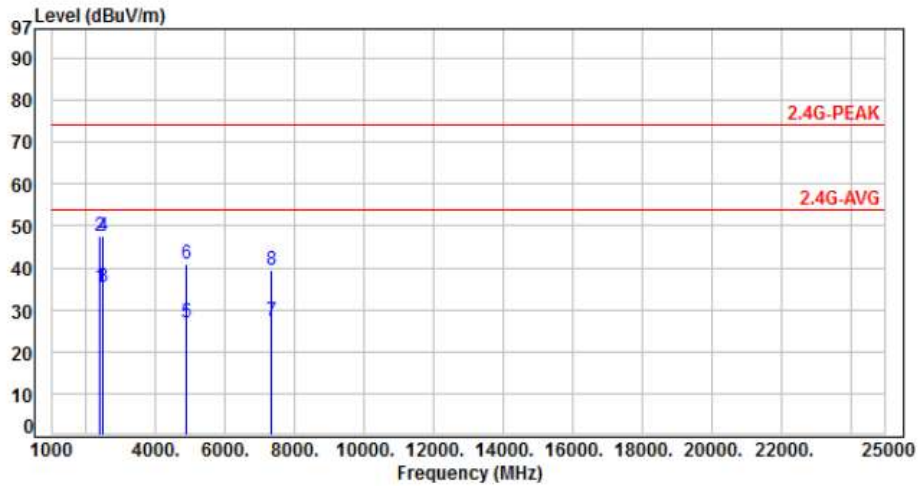

No.	Frequency (MHz)	Factor (dB)	Reading (dBuV)	Level (dBuV/m)	Limit (dBuV/m)	Margin (dB)	Detector	Height (cm)	Azimuth (deg)	P/F
1	2390.00	-14.61	50.10	35.49	54.00	-18.51	Average	325	347	P
2	2390.00	-14.61	62.33	47.72	74.00	-26.28	Peak	325	347	P
3	2483.50	-14.22	49.63	35.41	54.00	-18.59	Average	325	347	P
4	2483.50	-14.22	61.83	47.61	74.00	-26.39	Peak	325	347	P
5	4874.00	-6.63	33.65	27.02	54.00	-26.98	Average	100	300	P
6	4874.00	-6.63	47.52	40.89	74.00	-33.11	Peak	100	300	P
7	7311.00	-1.28	28.63	27.35	54.00	-26.65	Average	100	325	P
8	7311.00	-1.28	40.58	39.30	74.00	-34.70	Peak	100	325	P

Note: Level=Reading+Factor  
 Margin=Level-Limit  
 Factor=Antenna Factor + cable loss - Amplifier Factor



Power	: DC 5V from system	Pol/Phase	: VERTICAL
Test Mode	: Mode 2, CH11		:

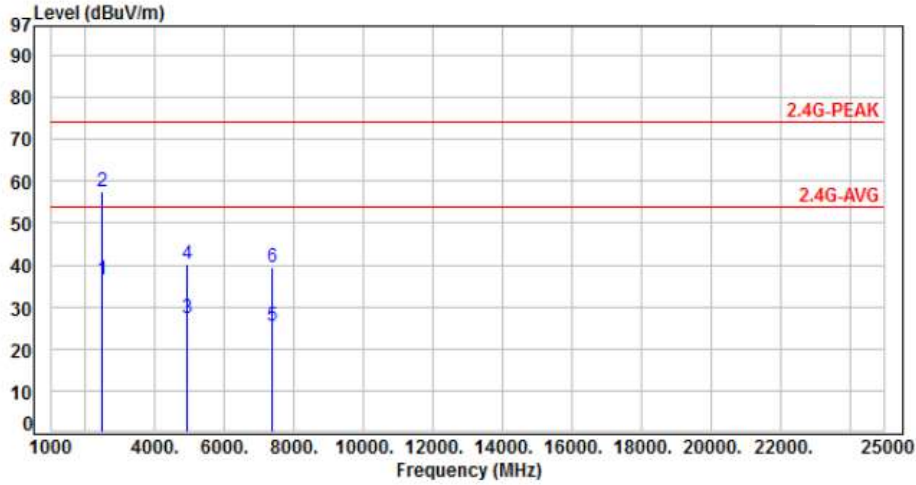

No.	Frequency (MHz)	Factor (dB)	Reading (dBuV)	Level (dBuV/m)	Limit (dBuV/m)	Margin (dB)	Detector	Height (cm)	Azimuth (deg)	P/F
1	2483.50	-14.22	50.60	36.38	54.00	-17.62	Average	100	152	P
2	2483.50	-14.22	71.60	57.38	74.00	-16.62	Peak	100	152	P
3	4924.00	-6.50	33.74	27.24	54.00	-26.76	Average	100	79	P
4	4924.00	-6.50	46.88	40.38	74.00	-33.62	Peak	100	79	P
5	7386.00	-1.19	26.55	25.36	54.00	-28.64	Average	100	63	P
6	7386.00	-1.19	40.56	39.37	74.00	-34.63	Peak	100	63	P

Note: Level=Reading+Factor  
 Margin=Level-Limit  
 Factor=Antenna Factor + cable loss - Amplifier Factor





Power	: DC 5V from system	Pol/Phase	: HORIZONTAL
Test Mode	: Mode 2, CH11		:

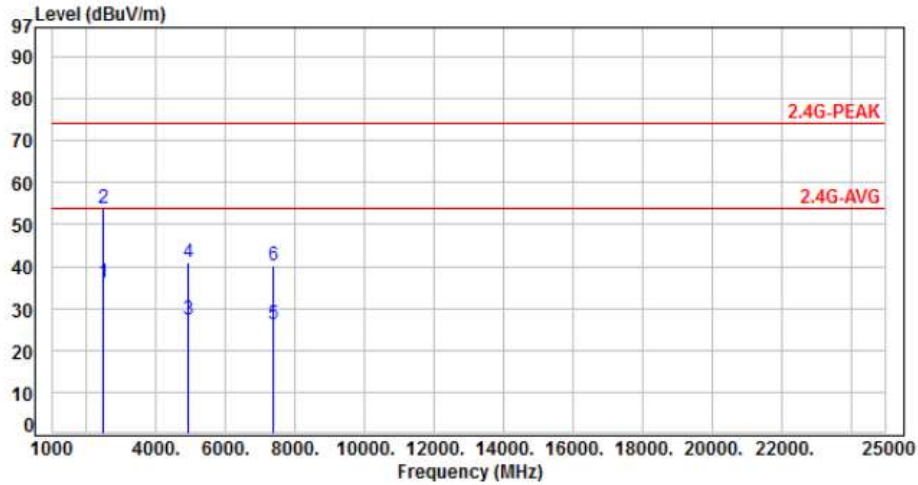

No.	Frequency (MHz)	Factor (dB)	Reading (dBuV)	Level (dBuV/m)	Limit (dBuV/m)	Margin (dB)	Detector	Height (cm)	Azimuth (deg)	P/F
1	2483.50	-14.22	50.23	36.01	54.00	-17.99	Average	363	360	P
2	2483.50	-14.22	67.90	53.68	74.00	-20.32	Peak	363	360	P
3	4924.00	-6.50	33.65	27.15	54.00	-26.85	Average	100	302	P
4	4924.00	-6.50	47.58	41.08	74.00	-32.92	Peak	100	302	P
5	7386.00	-1.19	27.27	26.08	54.00	-27.92	Average	100	352	P
6	7386.00	-1.19	41.53	40.34	74.00	-33.66	Peak	100	352	P

Note: Level=Reading+Factor  
 Margin=Level-Limit  
 Factor=Antenna Factor + cable loss - Amplifier Factor





Power	: DC 5V from system	Pol/Phase	: VERTICAL
Test Mode	: Mode 3, CH01		:

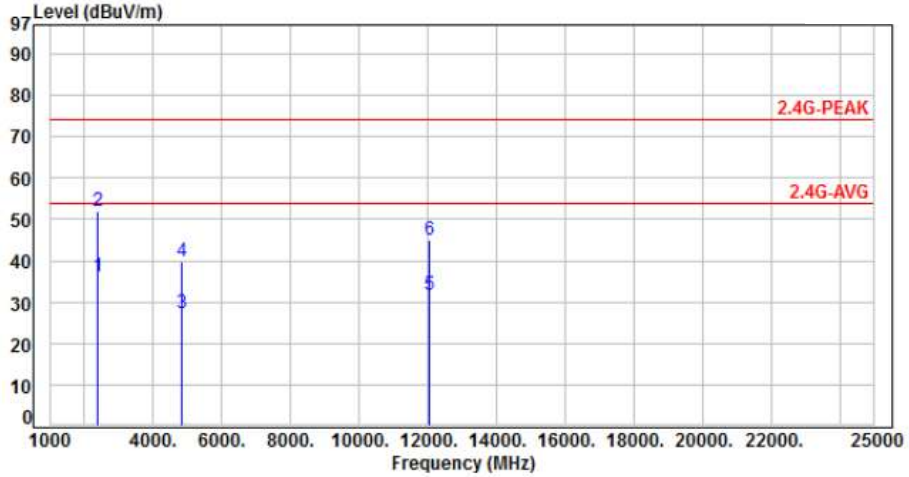

No.	Frequency (MHz)	Factor (dB)	Reading (dBuV)	Level (dBuV/m)	Limit (dBuV/m)	Margin (dB)	Detector	Height (cm)	Azimuth (deg)	P/F
1	2390.00	-14.61	50.60	35.99	54.00	-18.01	Average	100	160	P
2	2390.00	-14.61	66.71	52.10	74.00	-21.90	Peak	100	160	P
3	4824.00	-6.82	34.21	27.39	54.00	-26.61	Average	100	88	P
4	4824.00	-6.82	46.81	39.99	74.00	-34.01	Peak	100	88	P
5	12060.00	4.61	27.21	31.82	54.00	-22.18	Average	100	63	P
6	12060.00	4.61	40.32	44.93	74.00	-29.07	Peak	100	63	P

Note: Level=Reading+Factor  
 Margin=Level-Limit  
 Factor=Antenna Factor + cable loss - Amplifier Factor



Power	: DC 5V from system	Pol/Phase	: HORIZONTAL
Test Mode	: Mode 3, CH01		:

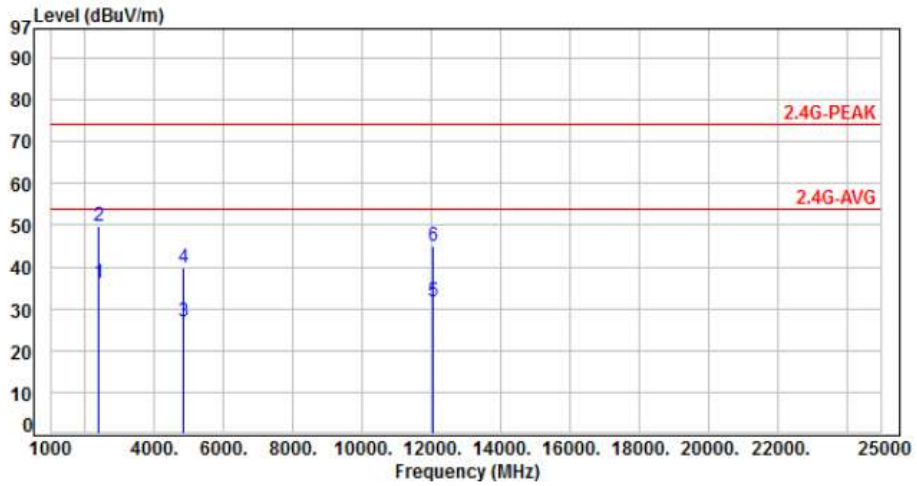

No.	Frequency (MHz)	Factor (dB)	Reading (dBuV)	Level (dBuV/m)	Limit (dBuV/m)	Margin (dB)	Detector	Height (cm)	Azimuth (deg)	P/F
1	2390.00	-14.61	50.89	36.28	54.00	-17.72	Average	388	360	P
2	2390.00	-14.61	64.26	49.65	74.00	-24.35	Peak	388	360	P
3	4824.00	-6.82	33.65	26.83	54.00	-27.17	Average	100	302	P
4	4824.00	-6.82	46.63	39.81	74.00	-34.19	Peak	100	302	P
5	12060.00	4.61	27.11	31.72	54.00	-22.28	Average	100	298	P
6	12060.00	4.61	40.53	45.14	74.00	-28.86	Peak	100	298	P

Note: Level=Reading+Factor  
 Margin=Level-Limit  
 Factor=Antenna Factor + cable loss - Amplifier Factor



Power	: DC 5V from system	Pol/Phase	: VERTICAL
Test Mode	: Mode 3, CH06		:

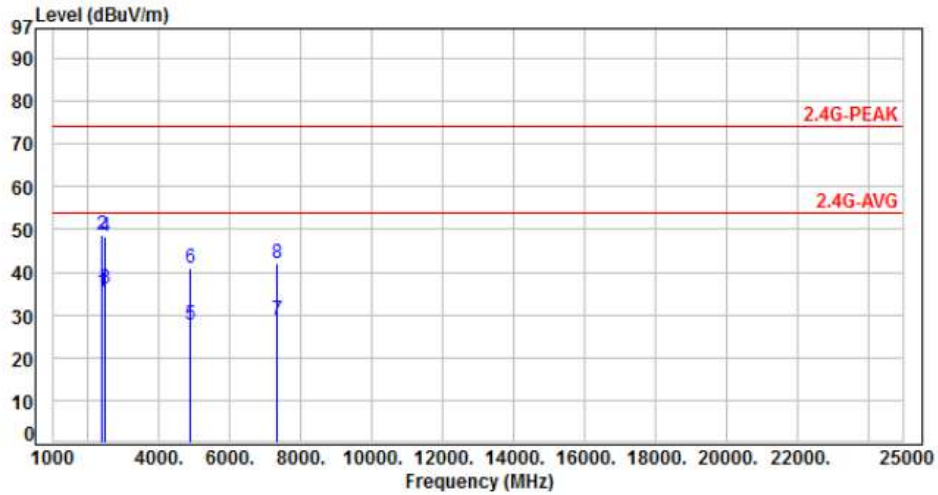

No.	Frequency (MHz)	Factor (dB)	Reading (dBUV)	Level (dBUV/m)	Limit (dBUV/m)	Margin (dB)	Detector	Height (cm)	Azimuth (deg)	P/F
1	2390.00	-14.61	50.12	35.51	54.00	-18.49	Average	120	163	P
2	2390.00	-14.61	63.42	48.81	74.00	-25.19	Peak	120	163	P
3	2483.50	-14.22	50.47	36.25	54.00	-17.75	Average	120	163	P
4	2483.50	-14.22	62.50	48.28	74.00	-25.72	Peak	120	163	P
5	4874.00	-6.63	34.22	27.59	54.00	-26.41	Average	100	82	P
6	4874.00	-6.63	47.60	40.97	74.00	-33.03	Peak	100	82	P
7	7311.00	-1.28	30.11	28.83	54.00	-25.17	Average	100	96	P
8	7311.00	-1.28	43.20	41.92	74.00	-32.08	Peak	100	96	P

Note: Level=Reading+Factor  
 Margin=Level-Limit  
 Factor=Antenna Factor + cable loss - Amplifier Factor



Power	: DC 5V from system	Pol/Phase	: HORIZONTAL
Test Mode	: Mode 3, CH06		:

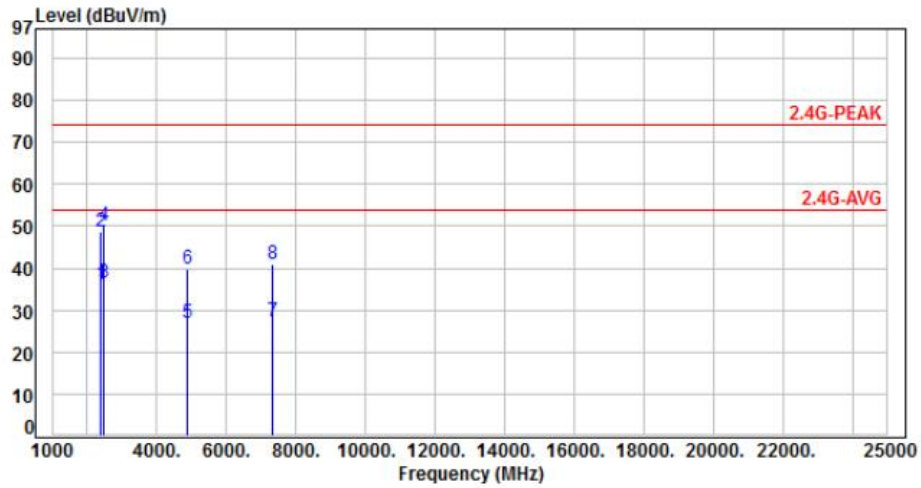

No.	Frequency (MHz)	Factor (dB)	Reading (dBuV)	Level (dBuV/m)	Limit (dBuV/m)	Margin (dB)	Detector	Height (cm)	Azimuth (deg)	P/F
1	2390.00	-14.61	50.89	36.28	54.00	-17.72	Average	325	347	P
2	2390.00	-14.61	63.21	48.60	74.00	-25.40	Peak	325	347	P
3	2483.50	-14.22	50.60	36.38	54.00	-17.62	Average	325	347	P
4	2483.50	-14.22	64.25	50.03	74.00	-23.97	Peak	325	347	P
5	4874.00	-6.63	33.52	26.89	54.00	-27.11	Average	100	354	P
6	4874.00	-6.63	46.33	39.70	74.00	-34.30	Peak	100	354	P
7	7311.00	-1.28	28.59	27.31	54.00	-26.69	Average	100	296	P
8	7311.00	-1.28	42.21	40.93	74.00	-33.07	Peak	100	296	P

Note: Level=Reading+Factor  
 Margin=Level-Limit  
 Factor=Antenna Factor + cable loss - Amplifier Factor



Power	: DC 5V from system	Pol/Phase	: VERTICAL
Test Mode	: Mode 3, CH11		:

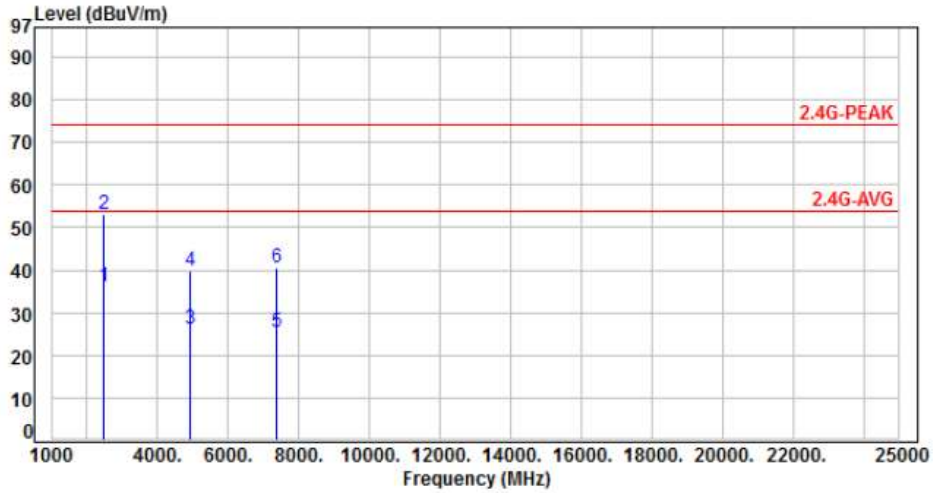

No.	Frequency (MHz)	Factor (dB)	Reading (dBuV)	Level (dBuV/m)	Limit (dBuV/m)	Margin (dB)	Detector	Height (cm)	Azimuth (deg)	P/F
1	2483.50	-14.22	50.35	36.13	54.00	-17.87	Average	108	146	P
2	2483.50	-14.22	67.20	52.98	74.00	-21.02	Peak	108	146	P
3	4924.00	-6.50	32.69	26.19	54.00	-27.81	Average	100	52	P
4	4924.00	-6.50	46.33	39.83	74.00	-34.17	Peak	100	52	P
5	7386.00	-1.19	26.50	25.31	54.00	-28.69	Average	100	81	P
6	7386.00	-1.19	41.59	40.40	74.00	-33.60	Peak	100	81	P

Note: Level=Reading+Factor  
 Margin=Level-Limit  
 Factor=Antenna Factor + cable loss - Amplifier Factor



Power	: DC 5V from system	Pol/Phase	: HORIZONTAL
Test Mode	: Mode 3, CH11		:

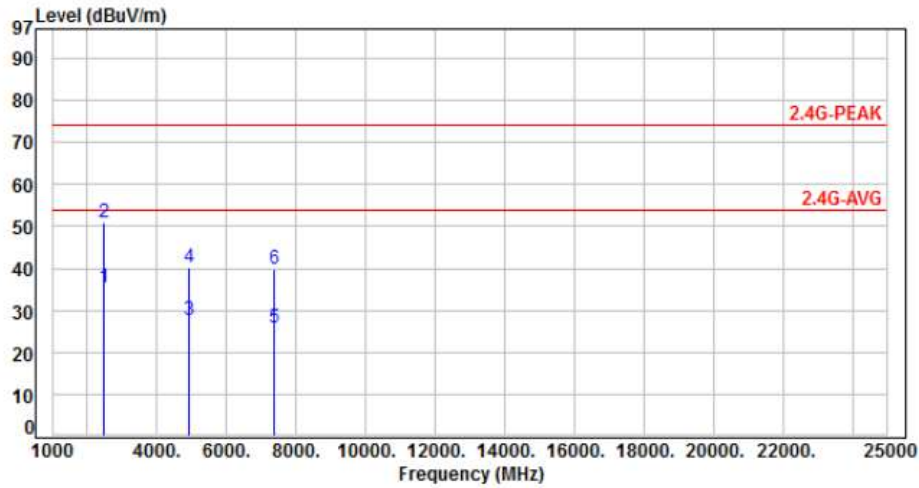

No.	Frequency (MHz)	Factor (dB)	Reading (dBuV)	Level (dBuV/m)	Limit (dBuV/m)	Margin (dB)	Detector	Height (cm)	Azimuth (deg)	P/F
1	2483.50	-14.22	49.66	35.44	54.00	-18.56	Average	373	352	P
2	2483.50	-14.22	65.22	51.00	74.00	-23.00	Peak	373	352	P
3	4924.00	-6.50	34.11	27.61	54.00	-26.39	Average	100	259	P
4	4924.00	-6.50	46.68	40.18	74.00	-33.82	Peak	100	259	P
5	7386.00	-1.19	27.15	25.96	54.00	-28.04	Average	100	306	P
6	7386.00	-1.19	40.96	39.77	74.00	-34.23	Peak	100	306	P

Note: Level=Reading+Factor  
 Margin=Level-Limit  
 Factor=Antenna Factor + cable loss - Amplifier Factor



Power	: DC 5V from system	Pol/Phase	: VERTICAL
Test Mode	: Mode 4, CH03		:

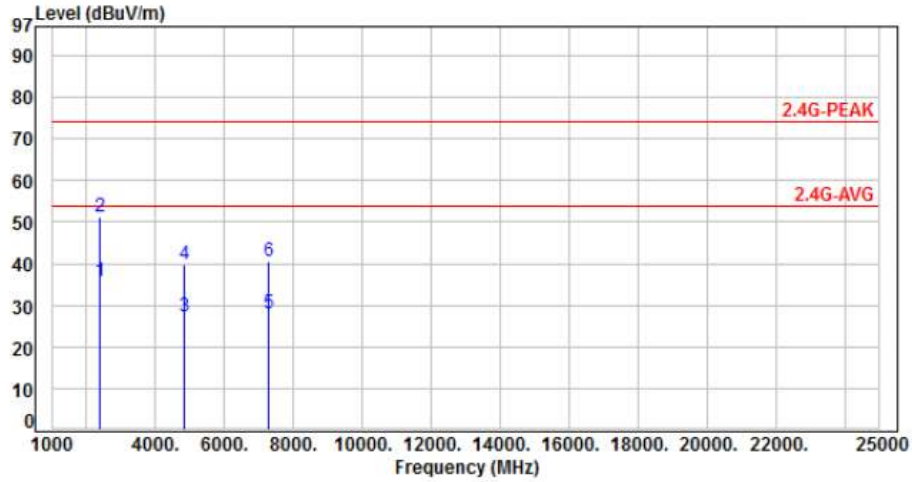

No.	Frequency (MHz)	Factor (dB)	Reading (dBuV)	Level (dBuV/m)	Limit (dBuV/m)	Margin (dB)	Detector	Height (cm)	Azimuth (deg)	P/F
1	2390.00	-14.61	50.51	35.90	54.00	-18.10	Average	126	150	P
2	2390.00	-14.61	65.91	51.30	74.00	-22.70	Peak	126	150	P
3	4844.00	-6.72	34.10	27.38	54.00	-26.62	Average	100	85	P
4	4844.00	-6.72	46.52	39.80	74.00	-34.20	Peak	100	85	P
5	7266.00	-1.49	29.35	27.86	54.00	-26.14	Average	100	104	P
6	7266.00	-1.49	42.11	40.62	74.00	-33.38	Peak	100	104	P

Note: Level=Reading+Factor  
 Margin=Level-Limit  
 Factor=Antenna Factor + cable loss - Amplifier Factor





Power	: DC 5V from system	Pol/Phase	: HORIZONTAL
Test Mode	: Mode 4, CH03		:

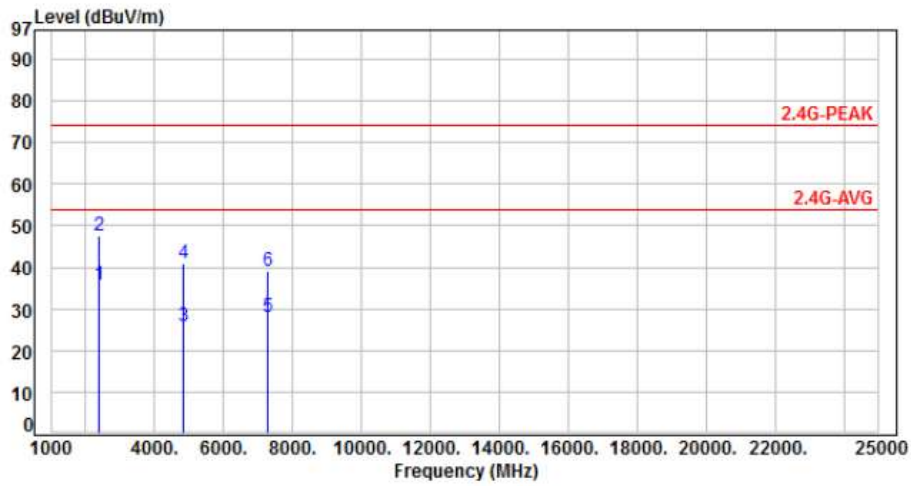

No.	Frequency (MHz)	Factor (dB)	Reading (dBuV)	Level (dBuV/m)	Limit (dBuV/m)	Margin (dB)	Detector	Height (cm)	Azimuth (deg)	P/F
1	2390.00	-14.61	50.23	35.62	54.00	-18.38	Average	338	358	P
2	2390.00	-14.61	62.10	47.49	74.00	-26.51	Peak	338	358	P
3	4844.00	-6.72	32.47	25.75	54.00	-28.25	Average	100	308	P
4	4844.00	-6.72	47.49	40.77	74.00	-33.23	Peak	100	308	P
5	7266.00	-1.49	29.53	28.04	54.00	-25.96	Average	100	316	P
6	7266.00	-1.49	40.47	38.98	74.00	-35.02	Peak	100	316	P

Note: Level=Reading+Factor  
 Margin=Level-Limit  
 Factor=Antenna Factor + cable loss - Amplifier Factor





Power	: DC 5V from system	Pol/Phase	: VERTICAL
Test Mode	: Mode 4, CH06		:

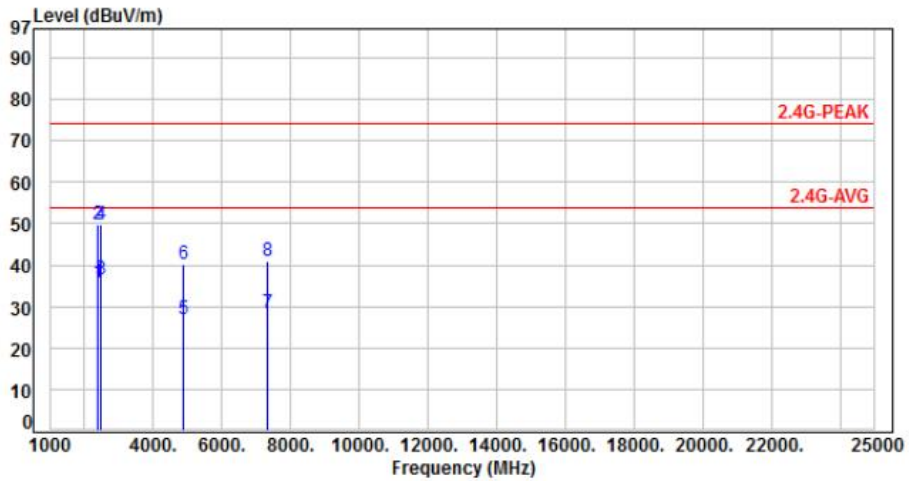

No.	Frequency (MHz)	Factor (dB)	Reading (dBuV)	Level (dBuV/m)	Limit (dBuV/m)	Margin (dB)	Detector	Height (cm)	Azimuth (deg)	P/F
1	2390.00	-14.61	50.30	35.69	54.00	-18.31	Average	100	149	P
2	2390.00	-14.61	64.33	49.72	74.00	-24.28	Peak	100	149	P
3	2483.50	-14.22	50.69	36.47	54.00	-17.53	Average	100	149	P
4	2483.50	-14.22	63.95	49.73	74.00	-24.27	Peak	100	149	P
5	4874.00	-6.63	33.58	26.95	54.00	-27.05	Average	100	66	P
6	4874.00	-6.63	46.84	40.21	74.00	-33.79	Peak	100	66	P
7	7311.00	-1.28	29.66	28.38	54.00	-25.62	Average	100	104	P
8	7311.00	-1.28	42.31	41.03	74.00	-32.97	Peak	100	104	P

Note: Level=Reading+Factor  
 Margin=Level-Limit  
 Factor=Antenna Factor + cable loss - Amplifier Factor



Power	: DC 5V from system	Pol/Phase	: HORIZONTAL
Test Mode	: Mode 4, CH06		:

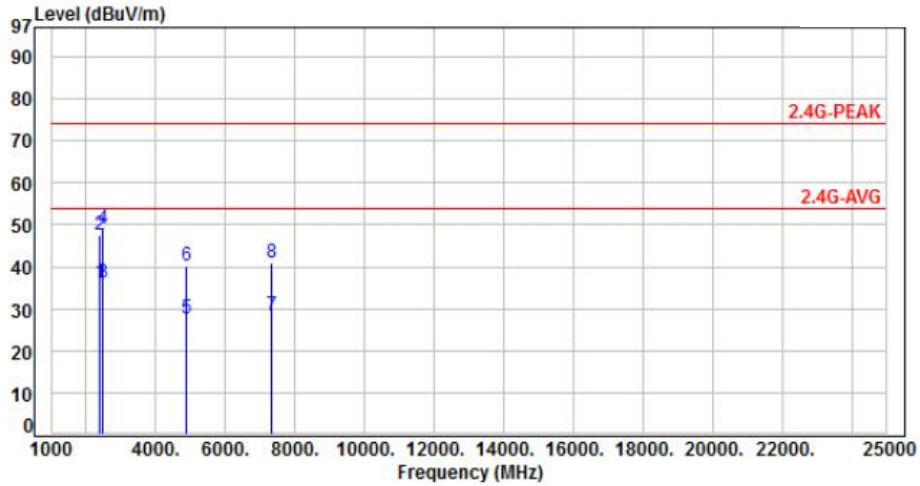

No.	Frequency (MHz)	Factor (dB)	Reading (dBuV)	Level (dBuV/m)	Limit (dBuV/m)	Margin (dB)	Detector	Height (cm)	Azimuth (deg)	P/F
1	2390.00	-14.61	50.60	35.99	54.00	-18.01	Average	333	360	P
2	2390.00	-14.61	62.10	47.49	74.00	-26.51	Peak	333	360	P
3	2483.50	-14.22	50.25	36.03	54.00	-17.97	Average	333	360	P
4	2483.50	-14.22	63.20	48.98	74.00	-25.02	Peak	333	360	P
5	4874.00	-6.63	34.25	27.62	54.00	-26.38	Average	100	315	P
6	4874.00	-6.63	46.93	40.30	74.00	-33.70	Peak	100	315	P
7	7311.00	-1.28	29.62	28.34	54.00	-25.66	Average	100	300	P
8	7311.00	-1.28	42.16	40.88	74.00	-33.12	Peak	100	300	P

Note: Level=Reading+Factor  
 Margin=Level-Limit  
 Factor=Antenna Factor + cable loss - Amplifier Factor



Power	: DC 5V from system	Pol/Phase	: VERTICAL
Test Mode	: Mode 4, CH09		:

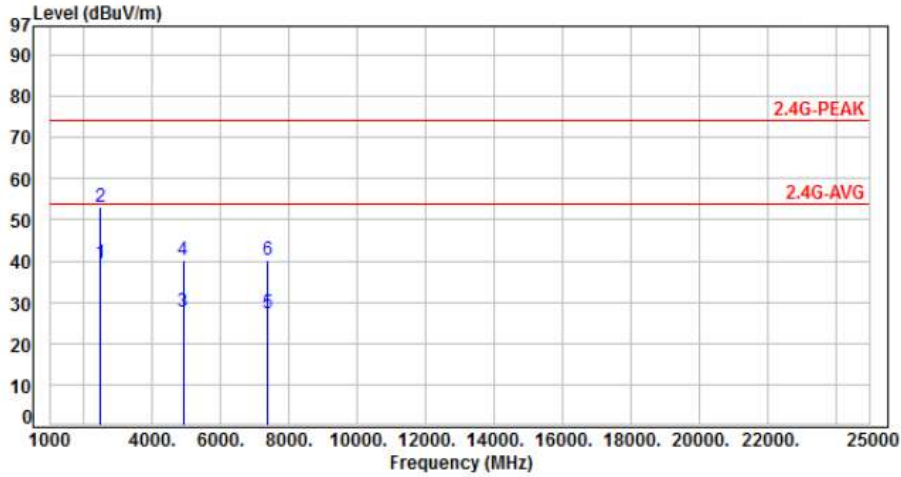

No.	Frequency (MHz)	Factor (dB)	Reading (dBuV)	Level (dBuV/m)	Limit (dBuV/m)	Margin (dB)	Detector	Height (cm)	Azimuth (deg)	P/F
1	2483.50	-14.22	53.60	39.38	54.00	-14.62	Average	116	152	P
2	2483.50	-14.22	67.40	53.18	74.00	-20.82	Peak	116	152	P
3	4904.00	-6.55	34.18	27.63	54.00	-26.37	Average	100	56	P
4	4904.00	-6.55	46.80	40.25	74.00	-33.75	Peak	100	56	P
5	7356.00	-1.26	28.50	27.24	54.00	-26.76	Average	100	84	P
6	7356.00	-1.26	41.34	40.08	74.00	-33.92	Peak	100	84	P

Note: Level=Reading+Factor  
 Margin=Level-Limit  
 Factor=Antenna Factor + cable loss - Amplifier Factor



Power	: DC 5V from system	Pol/Phase	: HORIZONTAL
Test Mode	: Mode 4, CH09		:

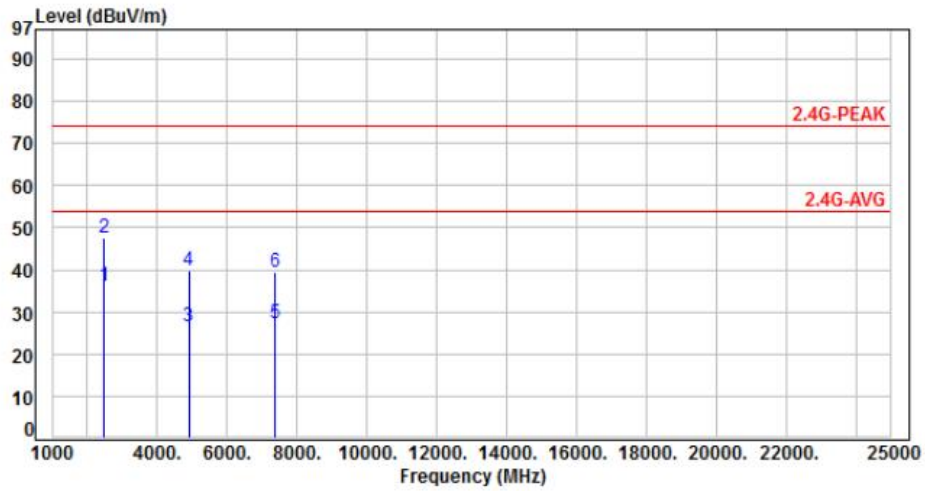

No.	Frequency (MHz)	Factor (dB)	Reading (dBUV)	Level (dBUV/m)	Limit (dBUV/m)	Margin (dB)	Detector	Height (cm)	Azimuth (deg)	P/F
1	2483.50	-14.22	50.21	35.99	54.00	-18.01	Average	352	349	P
2	2483.50	-14.22	61.70	47.48	74.00	-26.52	Peak	352	349	P
3	4904.00	-6.55	33.12	26.57	54.00	-27.43	Average	100	348	P
4	4904.00	-6.55	46.55	40.00	74.00	-34.00	Peak	100	348	P
5	7356.00	-1.26	28.70	27.44	54.00	-26.56	Average	100	309	P
6	7356.00	-1.26	40.86	39.60	74.00	-34.40	Peak	100	309	P

Note: Level=Reading+Factor  
 Margin=Level-Limit  
 Factor=Antenna Factor + cable loss - Amplifier Factor



### 6.7 Restricted Bands of Operation

Only spurious emissions are permitted in any of the frequency bands listed below:

MHz	MHz	MHz	GHz
0.09000 – 0.11000	16.42000 – 16.42300	399.9 – 410.0	4.500 – 5.250
0.49500 – 0.505**	16.69475 – 16.69525	608.0 – 614.0	5.350 – 5.460
2.17350 – 2.19050	16.80425 – 16.80475	960.0 – 1240.0	7.250 – 7.750
4.12500 – 4.12800	25.50000 – 25.67000	1300.0 – 1427.0	8.025 – 8.500
4.17725 – 4.17775	37.50000 – 38.25000	1435.0 – 1626.5	9.000 – 9.200
4.20725 – 4.20775	73.00000 – 74.60000	1645.5 – 1646.5	9.300 – 9.500
6.21500 – 6.21800	74.80000 – 75.20000	1660.0 – 1710.0	10.600 – 12.700
6.26775 – 6.26825	108.00000 – 121.94000	1718.8 – 1722.2	13.250 – 13.400
6.31175 – 6.31225	123.00000 – 138.00000	2200.0 – 2300.0	14.470 – 14.500
8.29100 – 8.29400	149.90000 – 150.05000	2310.0 – 2390.0	15.350 – 16.200
8.36200 – 8.36600	156.52475 – 156.52525	2483.5 – 2500.0	17.700 – 21.400
8.37625 – 8.38675	156.70000 – 156.90000	2655.0 – 2900.0	22.010 – 23.120
8.41425 – 8.41475	162.01250 – 167.17000	3260.0 – 3267.0	23.600 – 24.000
12.29000 – 12.29300	167.72000 – 173.20000	3332.0 – 3339.0	31.200 – 31.800
12.51975 – 12.52025	240.00000 – 285.00000	3345.8 – 3358.0	36.430 – 36.500
12.57675 – 12.57725	322.00000 – 335.40000	3600.0 – 4400.0	Above 38.6
13.36000 – 13.41000			

\*\* : Until February 1, 1999, this restricted band shall be 0.490-0.510 MHz



## 7. Test of Conducted Spurious Emission

### 7.1 Test Limit

Below -20dB of the highest emission level of operating band (In 100 kHz Resolution Bandwidth)

### 7.2 Test Procedure

- a. The transmitter output was connected to the spectrum analyzer via a low loss cable.
- b. Set RBW of spectrum analyzer to 100 KHz and VBW of spectrum analyzer to 300 KHz with convenient frequency span including 100 KHz bandwidth from band edge.
- c. Peak conducted output power measured within any 100 kHz outside the authorized frequency band shall be attenuated by at least 20dB relative to the maximum measured in-band peak PSD level.
- d. The band edges was measured and recorded.

### 7.3 Test Setup Layout

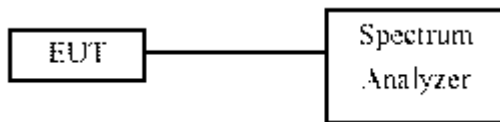

### 7.4 Test Result and Data

Note: Test plots refers to the following pages.



Modulation Type: 802.11b, CH 01

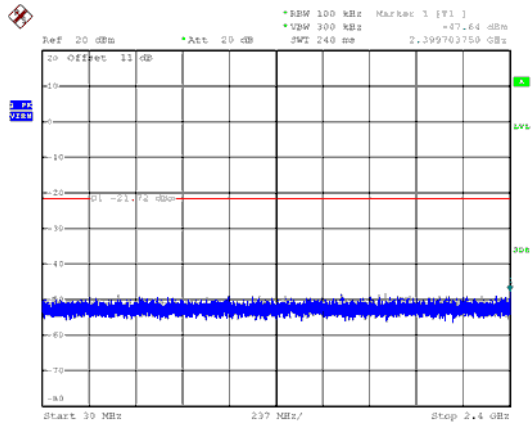

Modulation Type: 802.11b, CH 06

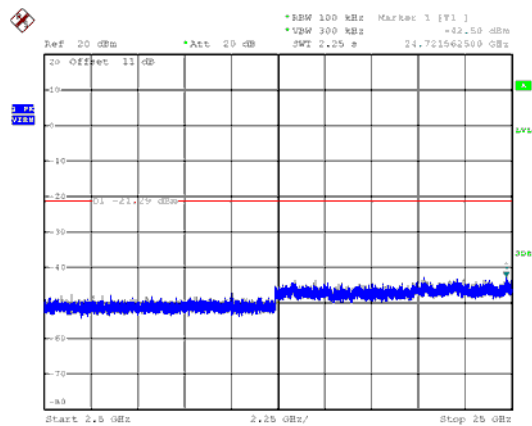
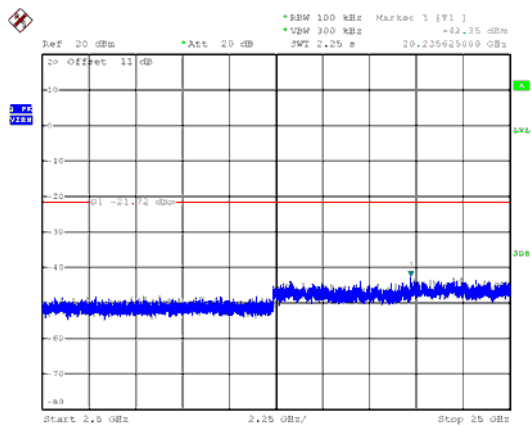
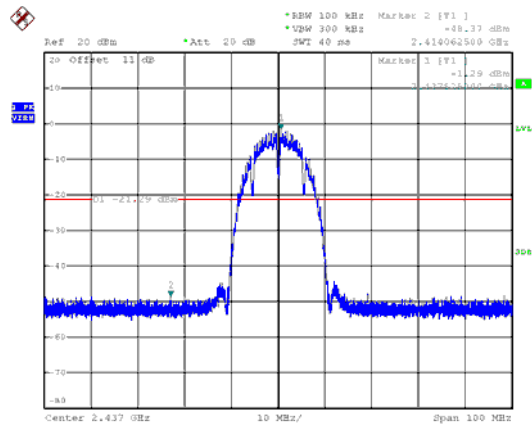
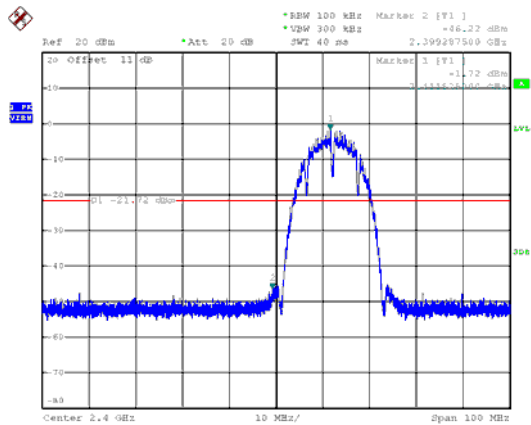
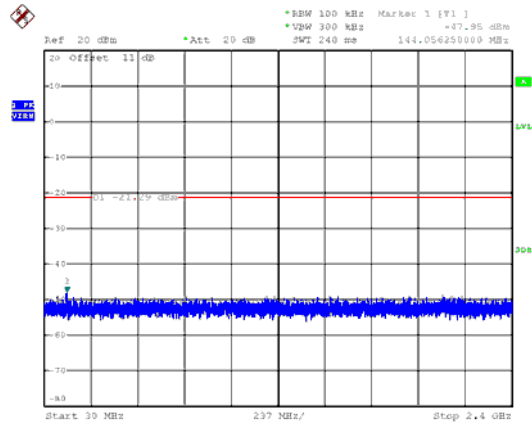



Modulation Type: 802.11b, CH 11

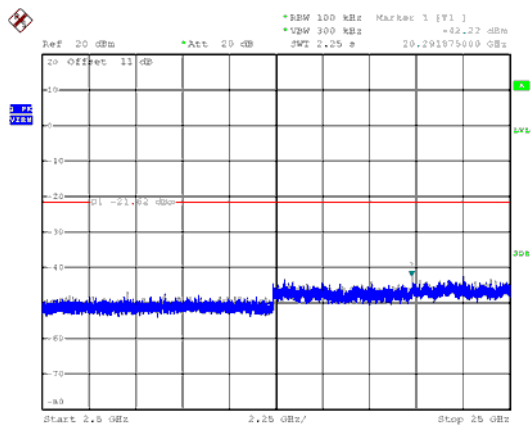
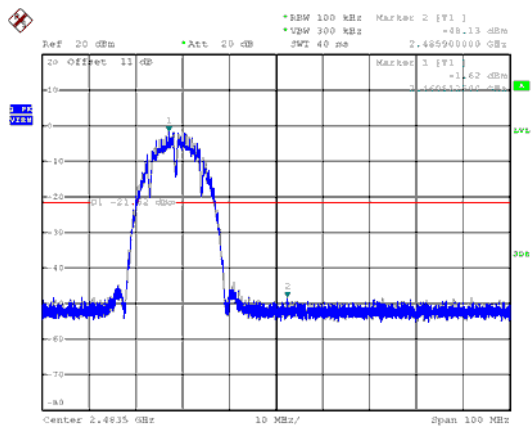
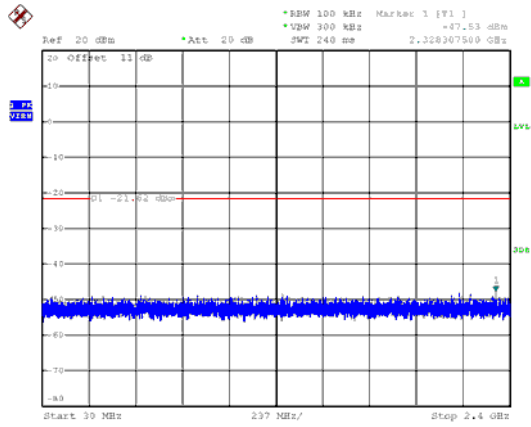





Modulation Type: 802.11g, CH 01

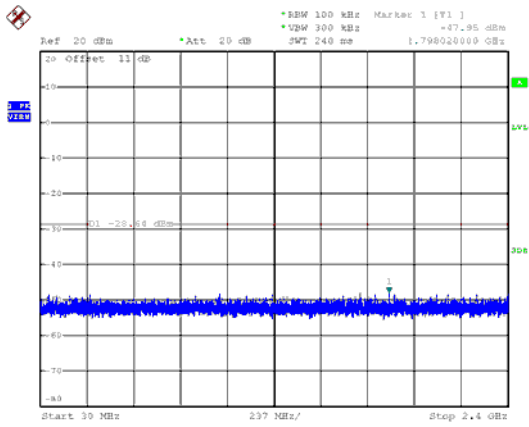

Modulation Type: 802.11g, CH 06

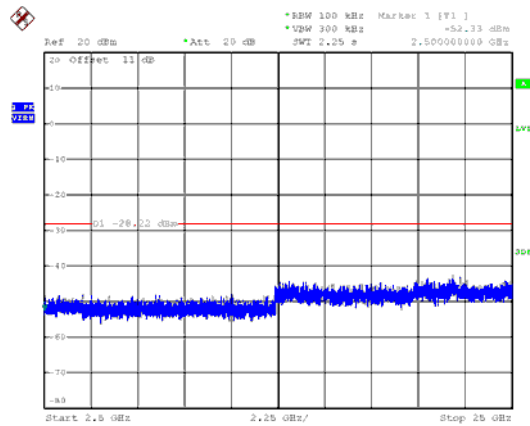
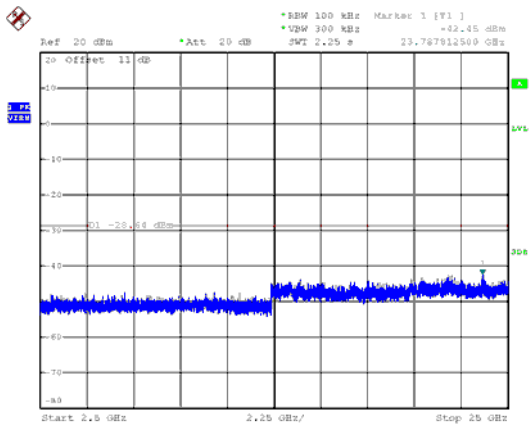
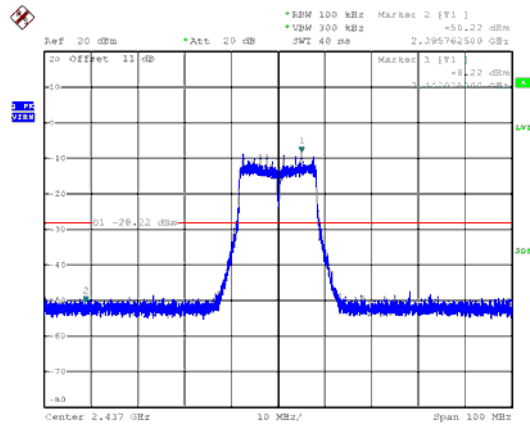
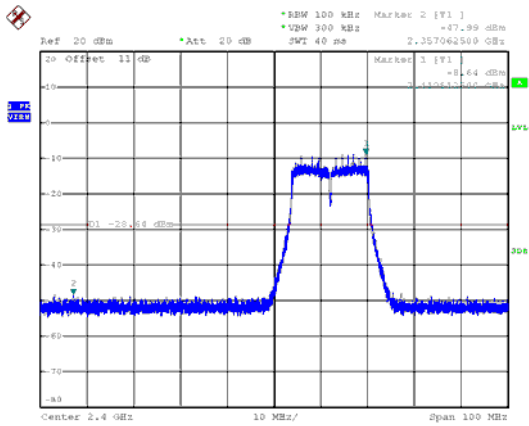
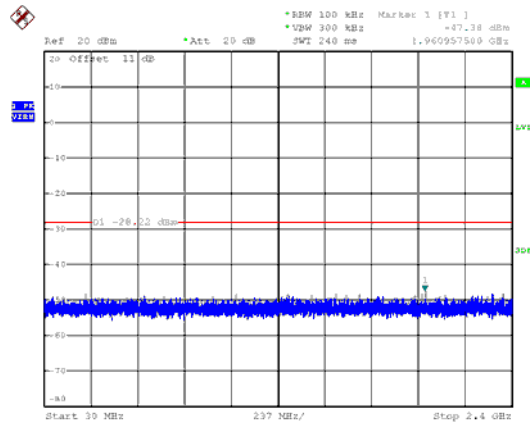



Modulation Type: 802.11g, CH 11

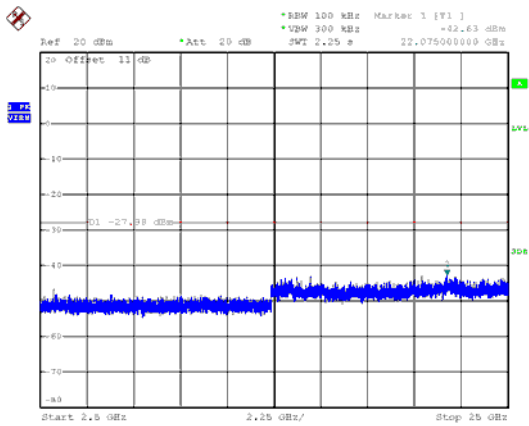
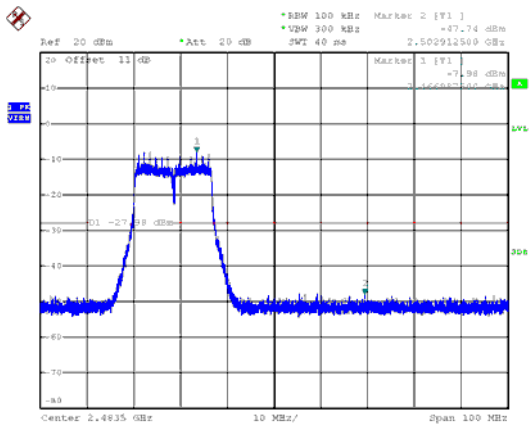
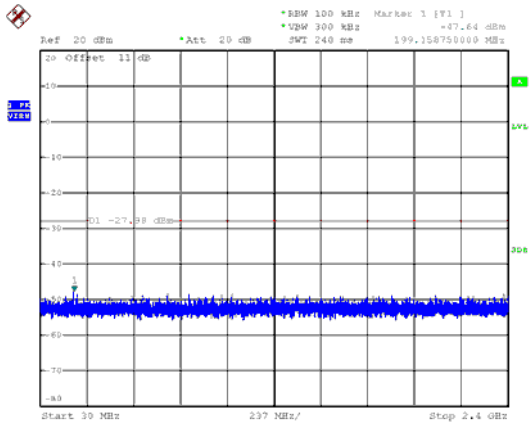



Modulation Type: 802.11n HT20, CH01

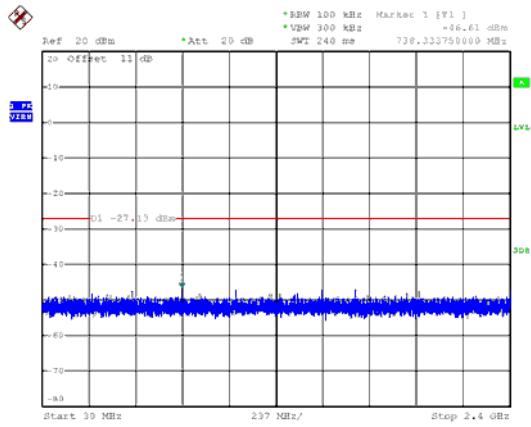

Modulation Type: 802.11n HT20, CH06

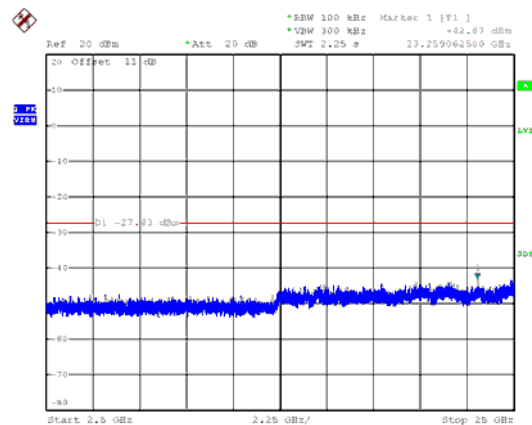
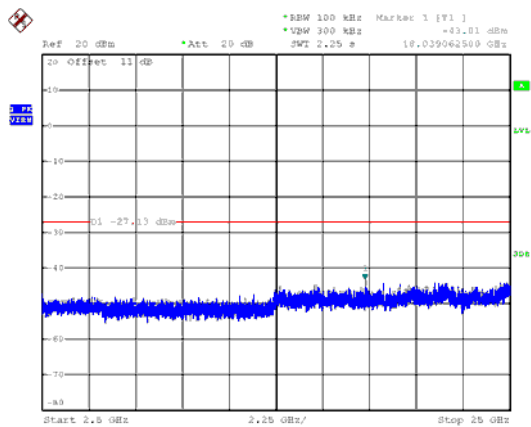
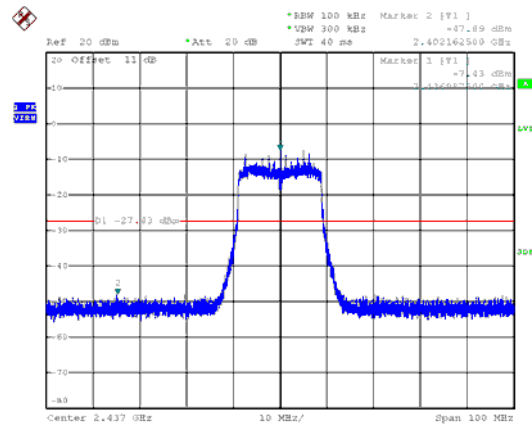
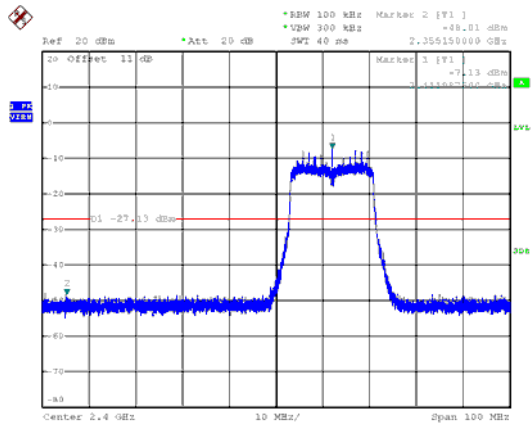
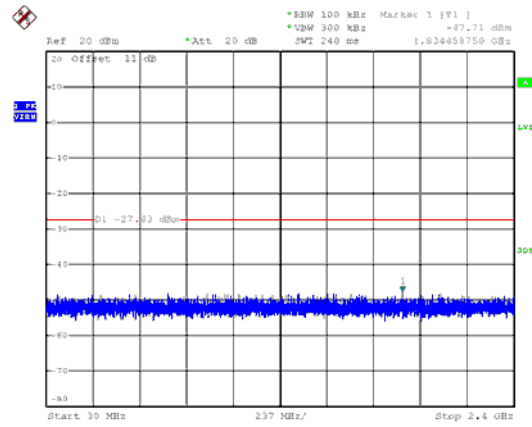



Modulation Type: 802.11n HT20, CH11

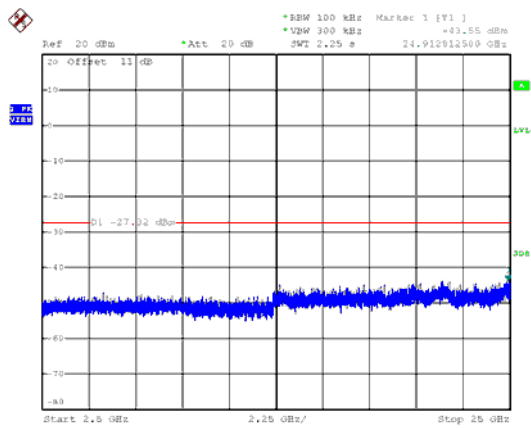
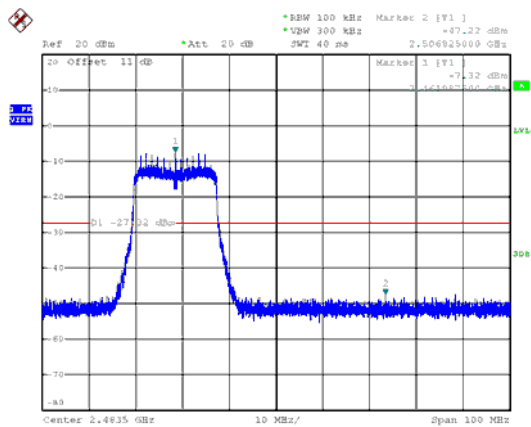
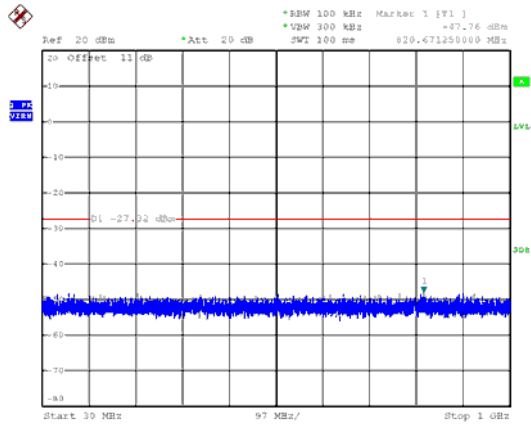



Modulation Type: 802.11n HT40, CH03

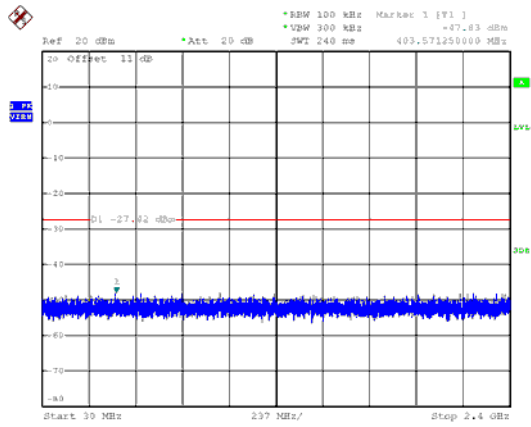

Modulation Type: 802.11n HT40, CH06

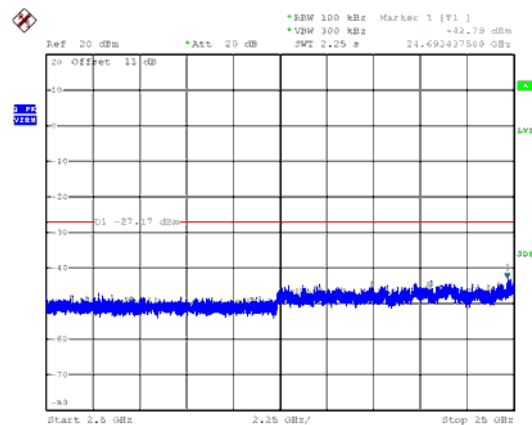
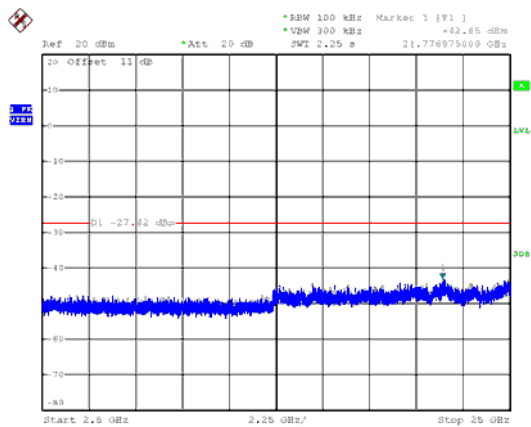
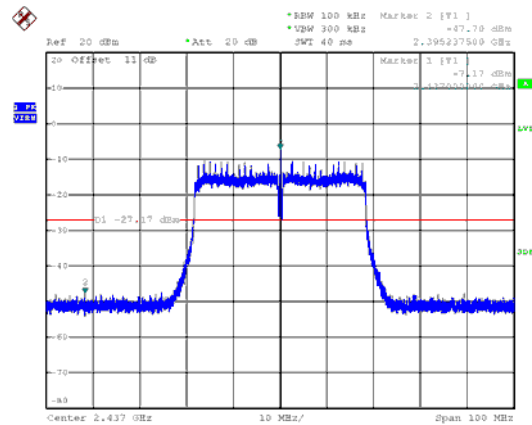
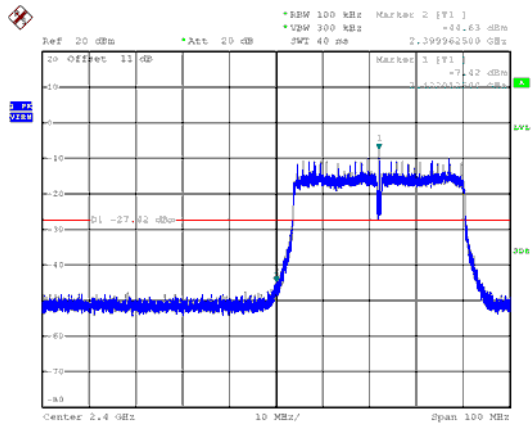
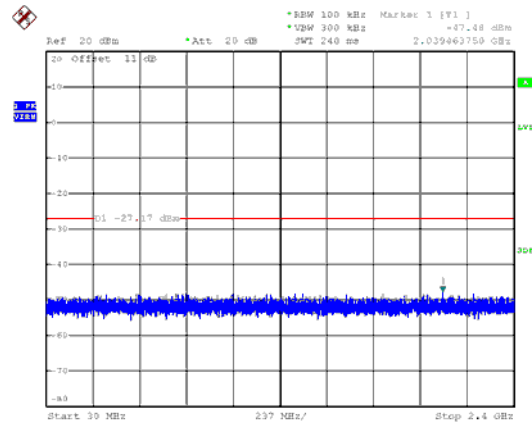



Modulation Type: 802.11n HT40, CH09

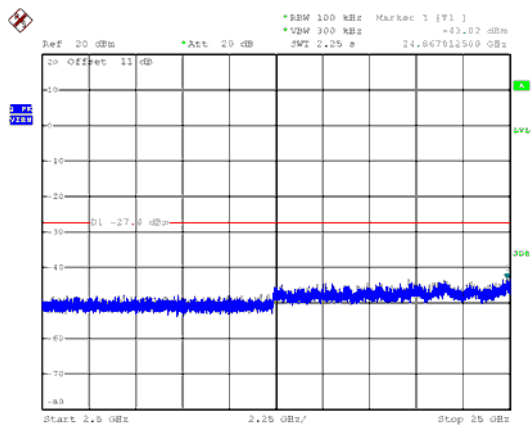
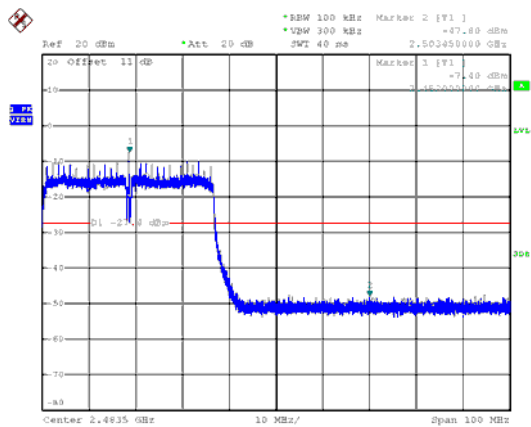
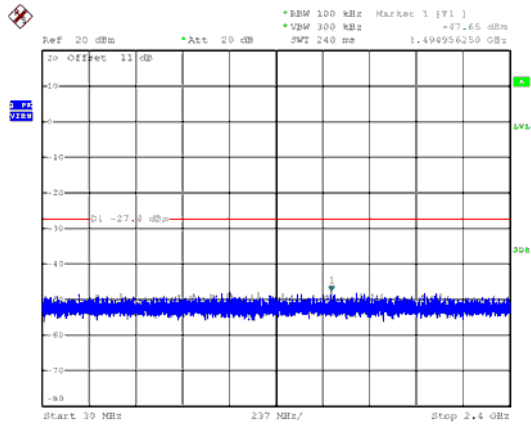



## 8. On Time, Duty Cycle and Measurement methods

### 8.1 Test Limit

None; for reporting purposes only.

### 8.2 Test Procedure

KDB 558074 Zero-Span Spectrum Analyzer Method.

### 8.3 Test Setup Layout

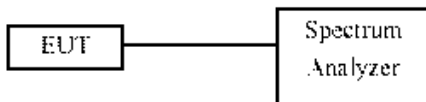

### 8.4 Test Result and Data

Modulation Type	On Time (msec)	Period Time (msec)	Duty Cycle (%)
802.11b	8.60	8.76	98.17%
802.11g	1.44	1.51	95.36%
802.11ac VHT20	1.35	1.56	86.54%
802.11ac VHT40	0.71	1.73	41.04%



Modulation Type: 802.11b (1Mbps)

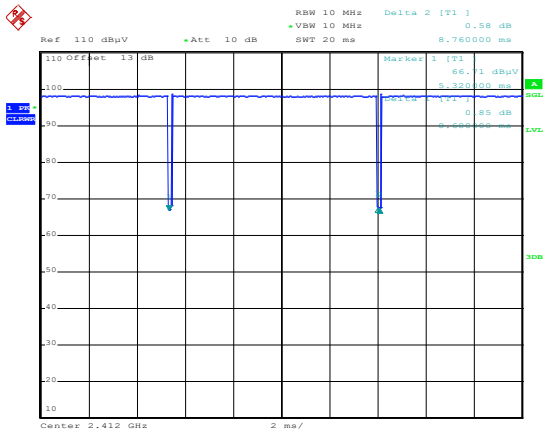

Modulation Type: 802.11g (6Mbps)

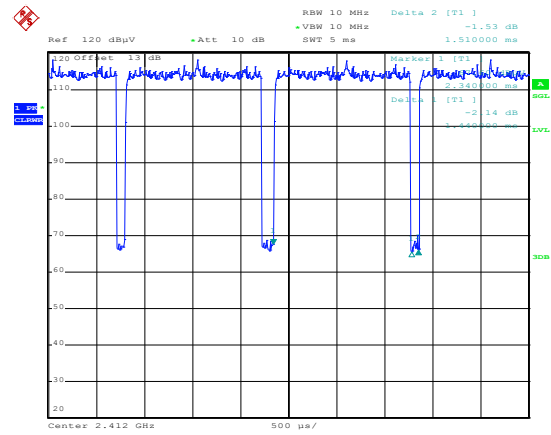

Modulation Type: 802.11ac VHT20 (6.5Mbps)

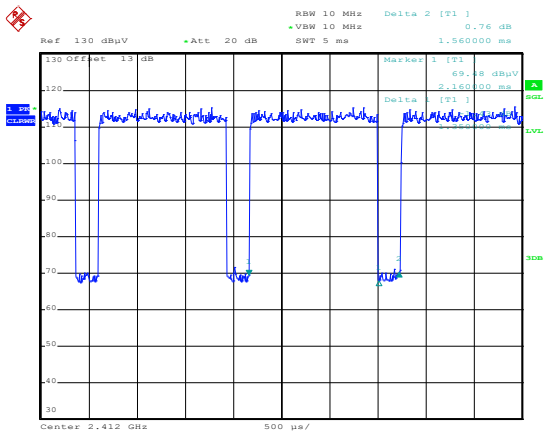

Modulation Type: 802.11ac VHT40 (13.5Mbps)

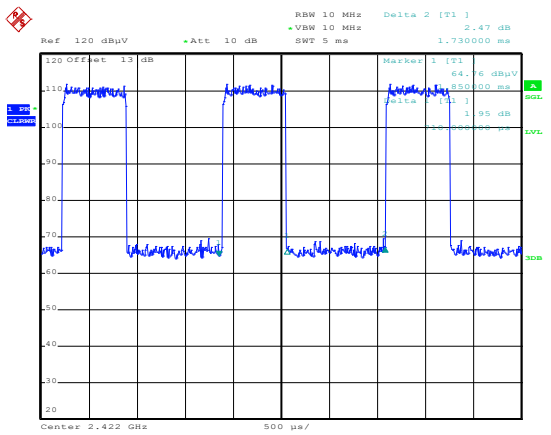





### 9. 6dB Bandwidth Measurement Data

#### 9.1 Test Limit

The minimum of 6dB Bandwidth Measurement is 0.5 MHz.

#### 9.2 Test Procedures

- a. The transmitter output was connected to the spectrum analyzer.
- b. Set RBW of spectrum analyzer to 1~5% of the emission bandwidth and VBW ≥ 3x RBW.
- c. The 6 dB bandwidth is defined as the total spectrum the power of which is higher than peak power minus 6 dB.
- d. The 6dB Bandwidth was measured and recorded.

#### 9.3 Test Setup Layout

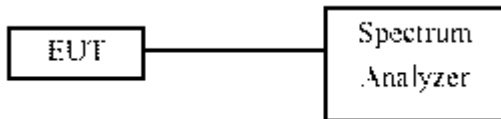

#### 9.4 Test Result and Data

Modulation Type	Channel	Frequency (MHz)	6dB Bandwidth (MHz)	Limit (MHz)
IEEE 802.11b (1Mbps)	01	2412	<b>10.10</b>	0.5
	06	2437	<b>10.10</b>	0.5
	11	2462	<b>10.10</b>	0.5
IEEE 802.11g (6Mbps)	01	2412	16.40	0.5
	06	2437	16.40	0.5
	11	2462	16.50	0.5
IEEE 802.11ac VHT20 (6.5Mbps)	01	2412	17.60	0.5
	06	2437	17.60	0.5
	11	2462	17.60	0.5
IEEE 802.11ac VHT40 (13.5Mbps)	03	2422	36.40	0.5
	06	2437	35.80	0.5
	09	2452	36.00	0.5



Modulation Type: 802.11b  
CH01

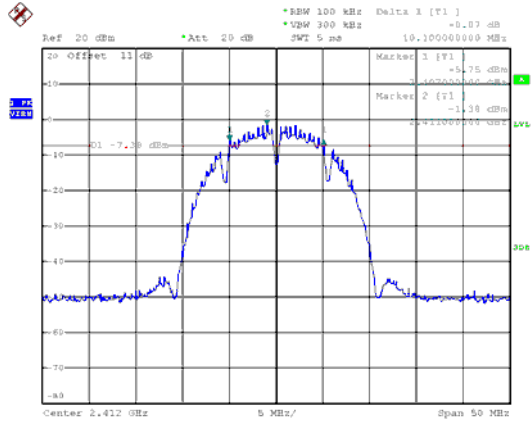

Modulation Type: 802.11g  
CH01

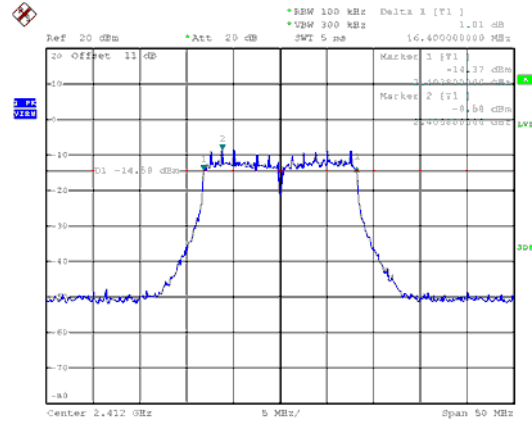

CH06

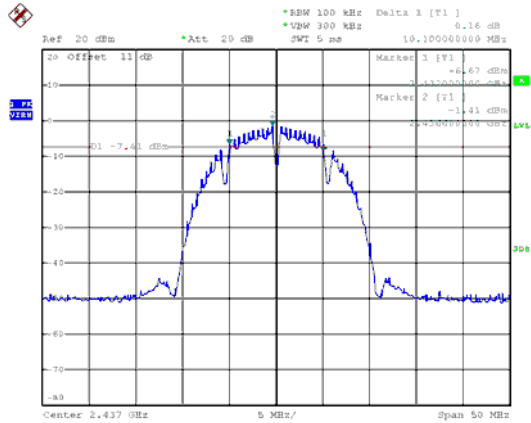

CH06

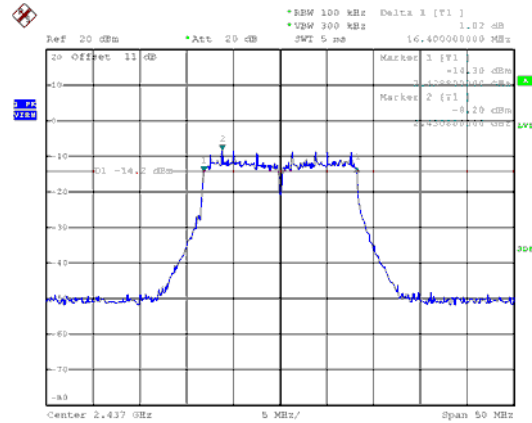

CH11

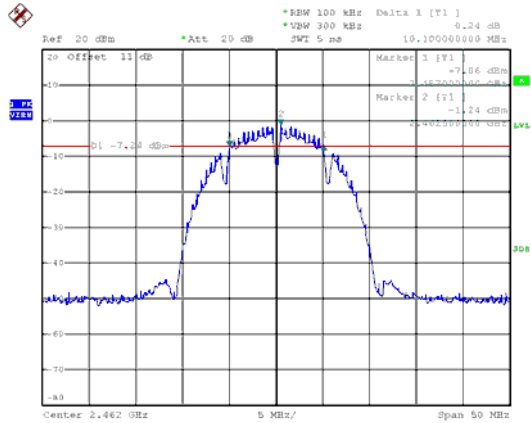

CH11

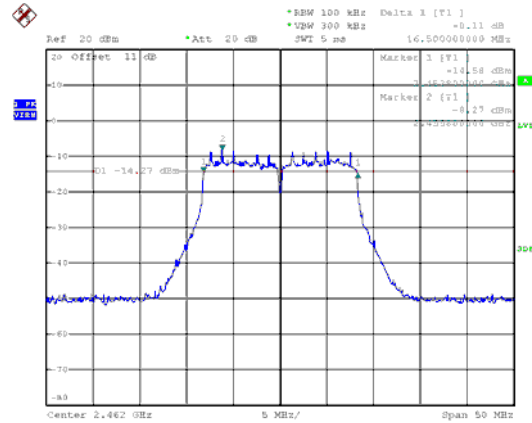



Modulation Type: 802.11ac VHT20  
CH01

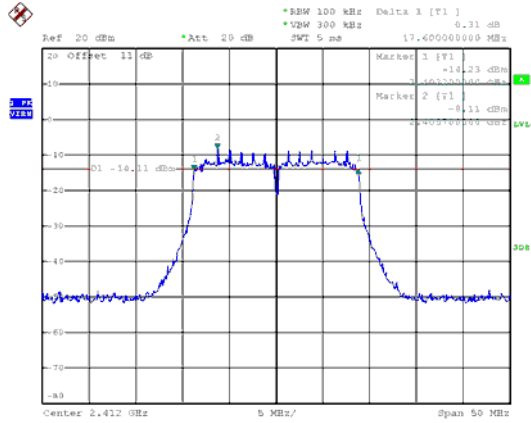

Modulation Type: 802.11ac VHT40  
CH03

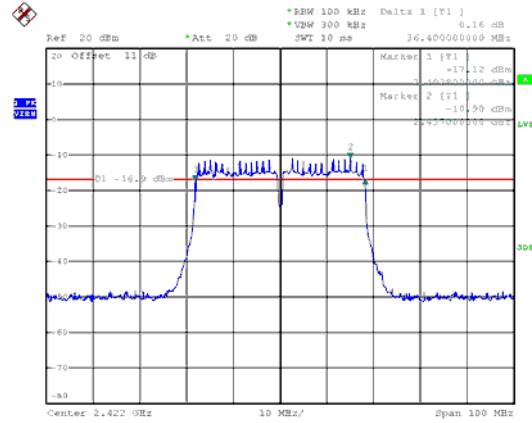

CH06

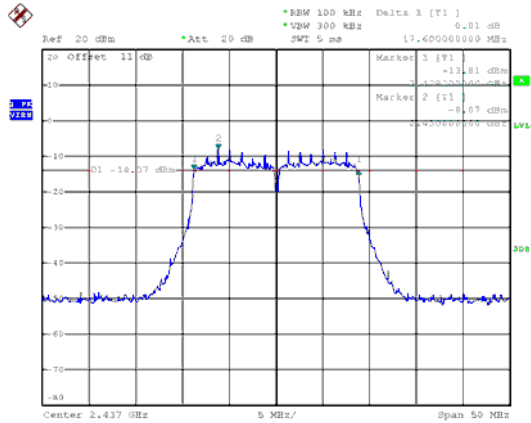

CH06

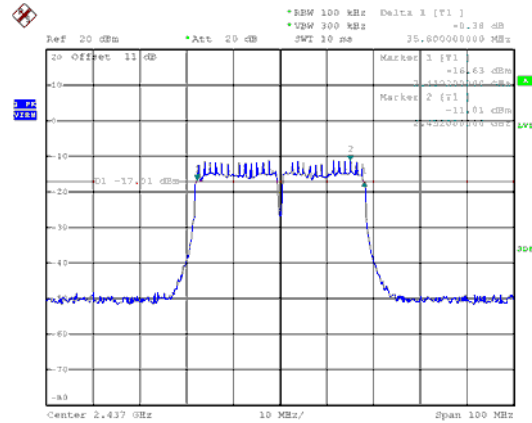

CH11

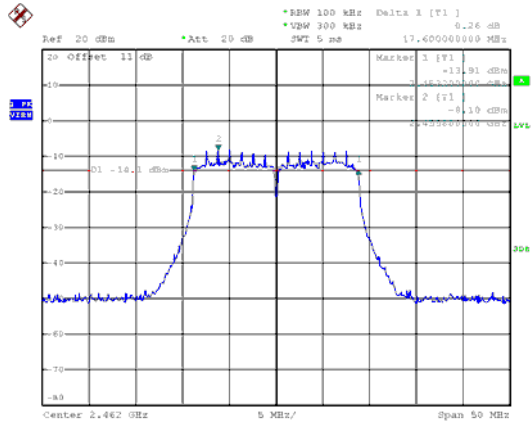

CH09

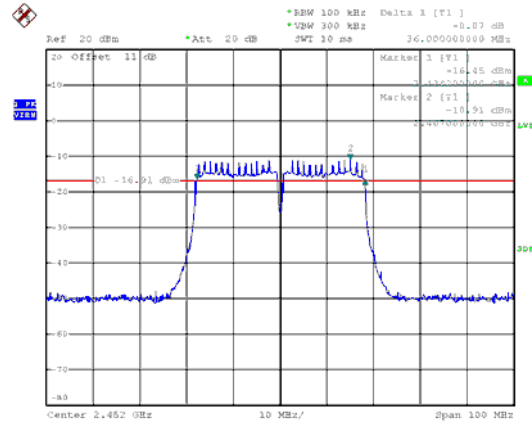



## 10. Maximum Peak and Average Output Power

### 10.1 Test Limit

The Maximum Peak Output Power Measurement is 30dBm.

If transmitting antennas of directional gain greater than 6 dBi are used, the peak output power shall be reduced by the amount in dB that the directional gain of the antenna exceeds 6 dBi

### 10.2 Test Procedures

The antenna port (RF output) of the EUT was connected to the input (RF input) of a power meter. Power was read directly from the meter and cable loss connection was added to the reading to obtain power at the EUT antenna terminal. The EUT Output Power was set to maximum to produce the worse case test result.

### 10.3 Test Setup Layout

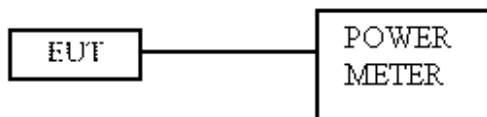

### 10.4 Test Result and Data

Modulation Type	Channel	Frequency (MHz)	Conducted(peak) output power (dBm)	Total PK power (dBm)	Total PK power (mW)	Powe Limit (dBm)
IEEE 802.11b (1Mbps)	1	2412	10.36	10.36	10.864	30.00
	6	2437	10.35	10.35	10.839	30.00
	11	2462	10.25	10.25	10.593	30.00
IEEE 802.11g (6Mbps)	1	2412	11.23	11.23	13.274	30.00
	6	2437	11.69	11.69	14.757	30.00
	11	2462	11.78	11.78	15.066	30.00
IEEE 802.11n HT20 (6.5Mbps)	1	2412	11.72	11.72	14.859	30.00
	6	2437	11.76	11.76	14.997	30.00
	11	2462	11.68	11.68	14.723	30.00
IEEE 802.11n HT40 (13.5Mbps)	3	2422	12.15	12.15	16.406	30.00
	6	2437	12.26	12.26	16.827	30.00
	9	2452	12.07	12.07	16.106	30.00
IEEE 802.11ac VHT20 (6.5Mbps)	1	2412	11.75	11.75	14.962	30.00
	6	2437	11.78	11.78	15.066	30.00
	11	2462	11.72	11.72	14.859	30.00
IEEE 802.11ac VHT40 (13.5Mbps)	3	2422	12.19	12.19	16.558	30.00
	6	2437	12.28	<b>12.28</b>	16.904	30.00
	9	2452	12.12	12.12	16.293	30.00



Modulation Type	Channel	Frequency (MHz)	Conducted(average) output power (dBm)	Total AV power (dBm)	Total AV power (mW)	Power Limit (dBm)
IEEE 802.11b (1Mbps)	1	2412	7.96	7.96	6.252	NA
	6	2437	7.97	7.97	6.266	NA
	11	2462	7.81	7.81	6.039	NA
IEEE 802.11g (6Mbps)	1	2412	2.65	2.65	1.841	NA
	6	2437	2.82	2.82	1.914	NA
	11	2462	2.86	2.86	1.932	NA
IEEE 802.11n HT20 (6.5Mbps)	1	2412	2.88	2.88	1.941	NA
	6	2437	2.91	2.91	1.954	NA
	11	2462	2.97	2.97	1.982	NA
IEEE 802.11n HT40 (13.5Mbps)	3	2422	3.13	3.13	2.056	NA
	6	2437	3.17	3.17	2.075	NA
	9	2452	3.15	3.15	2.065	NA
IEEE 802.11ac VHT20 (6.5Mbps)	1	2412	2.94	2.94	1.968	NA
	6	2437	2.95	2.95	1.972	NA
	11	2462	3.02	3.02	2.004	NA
IEEE 802.11ac VHT40 (13.5Mbps)	3	2422	3.17	3.17	2.075	NA
	6	2437	3.22	3.22	2.099	NA
	9	2452	3.19	3.19	2.084	NA

Note: Average power is for reference only.



### 11. Power Spectral Density

#### 11.1 Test Limit

The Maximum of Power Spectral Density Measurement is 8dBm.

If transmitting antennas of directional gain greater than 6 dBi are used, the power spectral density shall be reduced by the amount in dB that the directional gain of the antenna exceeds 6 dBi

#### 11.2 Test Procedures

- a. The transmitter output was connected to spectrum analyzer.
- b. The spectrum analyzer’s resolution bandwidth were set at 3kHz RBW and 30KHz VBW as that of the fundamental frequency. Set the sweep time=auto couple.
- c. The power spectral density was measured and recorded.

#### 11.3 Test Setup Layout

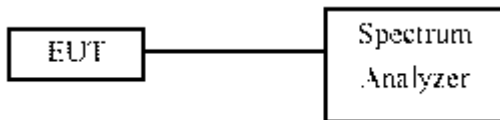

#### 11.4 Test Result and Data

Modulation Type	Channel	Frequency (MHz)	Maximum Power Density of 3 kHz Bandwidth (dBm)	Sum chain (dBm)	Duty Cycle CF(dB)	Total PSD (dBm)	Limit (dBm)
IEEE 802.11b (1Mbps)	01	2412	-8.4	-8.40	0.00	-8.40	8.00
	06	2437	-8.3	-8.30	0.00	-8.30	8.00
	11	2462	-8.33	-8.33	0.00	-8.33	8.00
IEEE 802.11g (6Mbps)	01	2412	-8.43	-8.43	0.00	-8.43	8.00
	06	2437	-8.26	-8.26	0.00	-8.26	8.00
	11	2462	-8.24	-8.24	0.00	-8.24	8.00
IEEE 802.11ac VHT20 (6.5Mbps)	01	2412	-8.34	-8.34	0.00	-8.34	8.00
	06	2437	-8.18	-8.18	0.00	-8.18	8.00
	11	2462	-8.12	-8.12	0.00	-8.12	8.00
IEEE 802.11ac VHT40 (13.5Mbps)	03	2422	-8	-8.00	0.00	-8.00	8.00
	06	2437	-8.02	-8.02	0.00	-8.02	8.00
	09	2452	-7.96	-7.96	0.00	-7.96	8.00



Modulation Type: 802.11b  
CH01

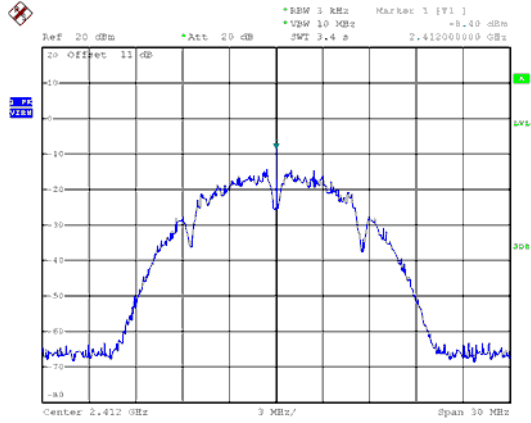

Modulation Type: 802.11b  
CH01

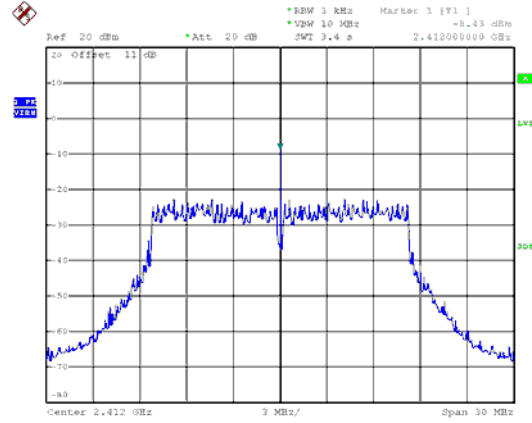

CH06

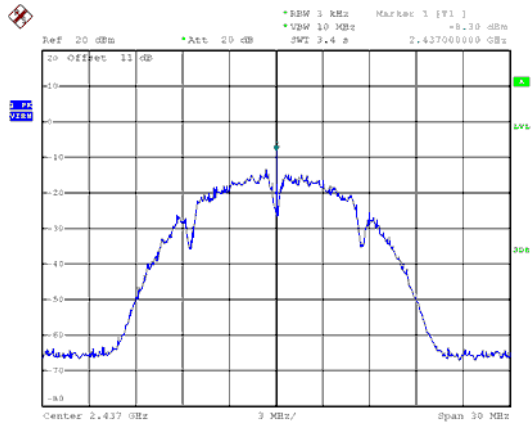

CH06

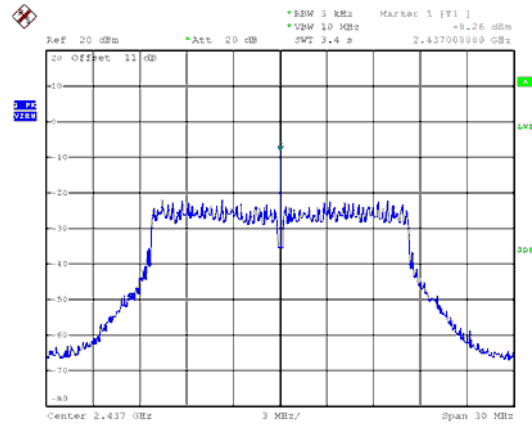

CH11

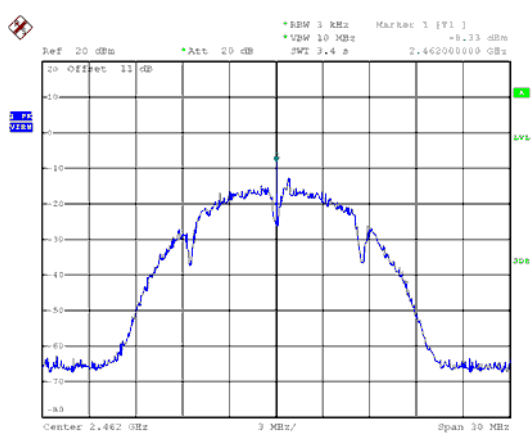

CH11

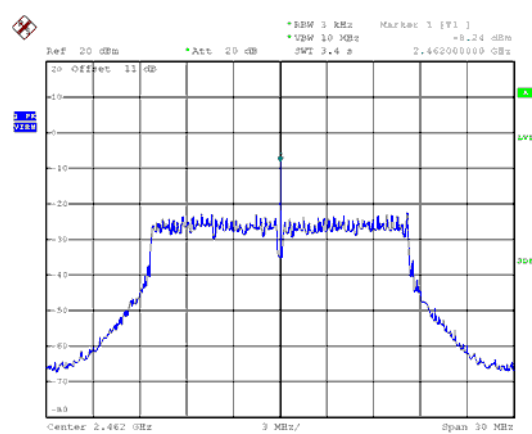



ANT A  
Modulation Type: 802.11ac VHT20  
CH01

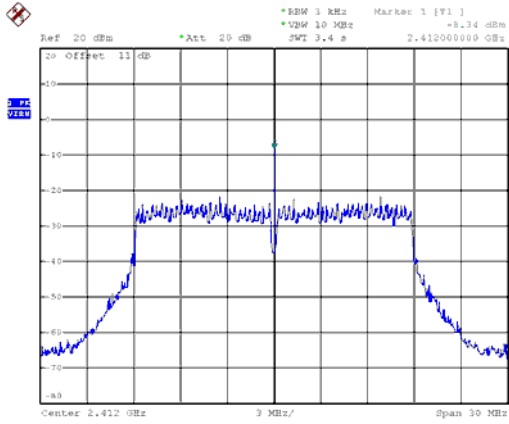

Modulation Type: 802.11ac VHT40  
CH03

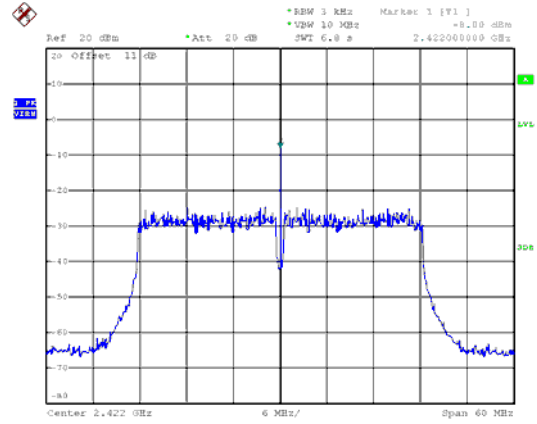

CH06

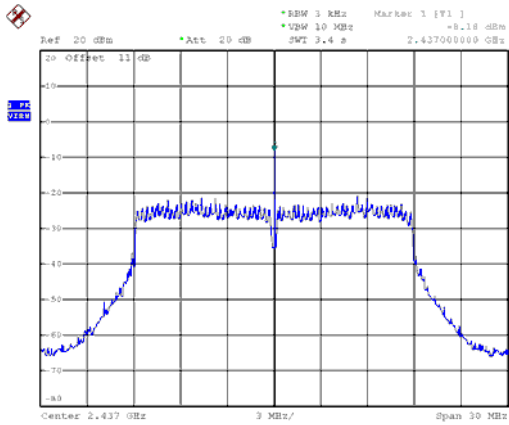

CH06

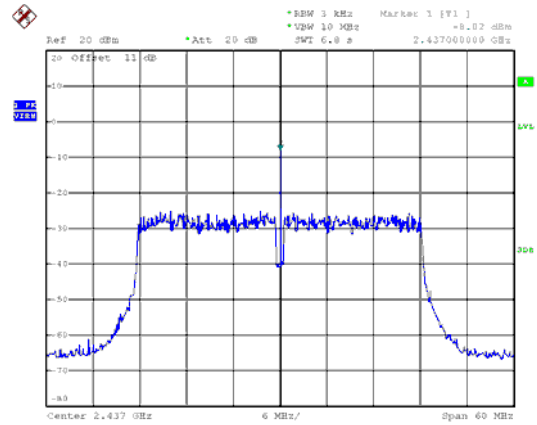

CH11

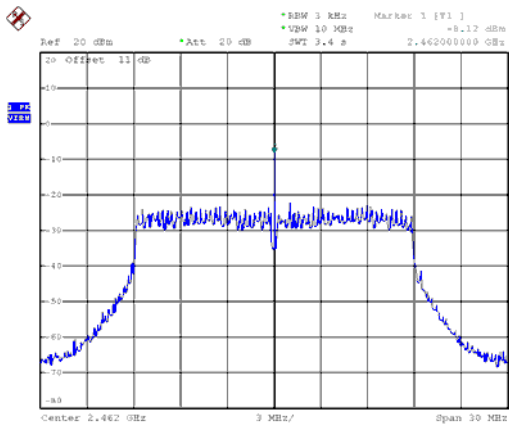

CH09

