

使用手冊

User's Manual

產品名稱: RF Module

廠牌: ViewSonic

型號: VS17803

1. General Description

The VS17803 is a highly-integrated IEEE 802.11 a/b/g/n/ac MAC/Baseband/RF WLAN and Bluetooth Baseband/RF single chip. For Wireless LAN (WLAN) operation, it supports 1-stream 802.11ac solution with Multi-user MIMO (Multiple-Input, Multiple-Output) STA mode with USB2.0 network interface controller. For Bluetooth operation, it supports Bluetooth 2.1/4.2 with USB interface controller.

The VS17803 baseband implements multiuser Multiple-Input Multiple-Output (MIMO) Orthogonal Frequency Division Multiplexing (OFDM) STA mode with one transmit and one receive path (1T1R). Features include one spatial stream transmission, short Guard Interval (GI) of 400ns, spatial spreading, and support for variant channel bandwidths.

Moreover, RTL8821CU-CG

provides one spatial stream Space-Time Block Code (STBC) and Low Density Parity Check (LDPC) to extend the range of transmission. As the recipient, the RTL8821CU-CG also supports explicit sounding packet feedback that helps senders with beamforming capability.

For legacy compatibility, Direct Sequence Spread Spectrum (DSSS), Complementary Code Keying (CCK) and OFDM baseband processing are included to support all IEEE 802.11a, 802.11b and 802.11g data rates. Differential phase shift keying modulation schemes, DBPSK and DQPSK with data scrambling capability, are available. CCK provides support for legacy data rates, with long or short preamble. The high speed FFT/IFFT paths are combined with BPSK, QPSK, 16QAM, 64QAM and 256QAM modulation of the individual subcarriers. The compatible coding rate of 1/2, 2/3, 3/4, and 5/6 provides up to 433.3Mbps for IEEE 802.11ac with MIMO-OFDM.

The VS17803 builds in an enhanced signal detector, an adaptive frequency domain equalizer, and a soft-decision Viterbi decoder to alleviate severe multi-path effects and mutual interference in the reception of multiple streams. Robust interference detection and suppression are provided to protect against Bluetooth, cordless phone, and microwave oven interference.

Receive vector diversity for multi-stream application is implemented for efficient utilization of the MIMO channel. Efficient IQ-imbalance, DC offset, phase noise, frequency offset, and timing offset compensations are provided for the radio frequency front-end.

The VS17803 supports fast receiver Automatic Gain Control (AGC) with synchronous and asynchronous control loops among antennas, antenna diversity functions, and adaptive transmit power control functions to obtain better performance in the analog portions of the transceiver.

The VS17803 MAC supports 802.11e for multimedia applications, 802.11i and WAPI (Wireless Authentication Privacy Infrastructure) for security, and 802.11n/ac for enhanced MAC protocol efficiency. Protocol efficiency is significantly improved by using packet aggregation techniques, such as A-MPDU with BA and A-MSDU. Power saving mechanisms, such as Legacy Power Save, U-APSD, and MIMO, can reduce the power wasted during idle time. They can also compensate for the extra power required to transmit MIMO-OFDM. The RTL8821CU-CG provides simple legacy and 20MHz/40MHz/80MHz co-existence mechanism to ensure backward and network compatibility.

The VS17803 Bluetooth controller complies with Bluetooth core specification v4.2, and supports dual mode (BR/EDR + AMP + Low Energy Controllers). It is backward compatible with previous versions including v2.1 + EDR and v3.0 + HS. For BR/EDR, it can support scatternet topology up to four active links in slave mode, and seven active links in master mode. For Low Energy, it supports multiple states and allows eight active links in master mode. Both BR/EDR and LE can operate simultaneously.

2. Features

General Information

- CMOS MAC, Baseband PHY and RF in a single chip for IEEE 802.11a/b/g/n/ac compatible WLAN
- Support 802.11ac 1x1, Wave-2 compliant with MU-MIMO STA mode
- Complete 802.11n MIMO solution for 2.4GHz and 5Ghz band
- Maximum PHY data rate up to 86.7Mbps using 20MHz bandwidth, 200Mbps using 40MHz bandwidth, and 433.3Mbps using 80MHz bandwidth.
- Backward compatible with 802.11a/b/g devices while operating at 802.11n data rates
- Backward compatible with 802.11a/n devices while operating at 802.11ac data rates.

Host Interface

- Complies with USB 2.0 for WLAN and BT controller
- USB Multi-Function for both BT (USB function 0) and WLAN (USB function 1)
- USB LPM/Selective Suspend supported

Standards Supported

- IEEE 802.11a/b/g/n/ac compatible WLAN
- IEEE 802.11e QoS Enhancement (WMM)
- IEEE 802.11i (WPA, WPA2). Open, shared key, and pair-wise key authentication services
- IEEE 802.11h DFS, TPC, Spectrum Measurement
- IEEE 802.11k Radio Resource Measurement
- WAPI (Wireless Authentication Privacy Infrastructure) certified.
- Cisco Compatible Extensions (CCX) for WLAN devices

MAC Features

- Frame aggregation for increased MAC efficiency (A-MSDU, A-MPDU)
- Low latency immediate Block Acknowledgement (BA)
- Long NAV for media reservation with CF-End for NAV release
- Transmit Opportunity (TXOP) Short Inter-Frame Space (SIFS) bursting for higher multimedia bandwidth
- WiFi Direct supports wireless peer to peer applications.
- WiFi NAN (Neighborhood Area Network) support
- PHY-level spoofing to enhance legacy compatibility
- Channel management and co-existence
- Multiple BSSID feature allows the RTL8821CU-CG to assume multiple MAC identities when used as a wireless bridge
- WiFi FTM (Fine Time Measurement) supported
- WiFi TDLS (Tunneled Direct Link Setup) Supported

Other Features

- Supports Wake-On-WLAN via Magic Packet and Wake-up frame
- Transmit Beamforming
- Support S3/S4 AES/TKIP group key update
- Support Network List Offload
- CCA on secondary through RTS/CTS handshake.
- Support TCP/UDP/IP checksum offload

Peripheral Interfaces

- Up to 15 General Purpose Input/Output pins
- Three configurable LED pins (mux with GPIO pins)
- Generates 40MHz clock for peripheral chip
- Single external power source 3.3V only

PHY Features

- IEEE 802.11ac OFDM
- IEEE 802.11n OFDM
- One Transmit and One Receive path
- 5MHz / 10MHz / 20MHz / 40MHz / 80MHz bandwidth transmission
- Support 2.4GHz and 5GHz band channels
- Short Guard Interval (400ns)
- Sounding packet.
- DSSS with DBPSK and DQPSK, CCK modulation with long and short preamble
- OFDM with BPSK, QPSK, 16QAM, 64QAM and 256QAM modulation.
- Convolutional Coding Rate: 1/2, 2/3, 3/4, and 5/6
- Maximum data rate 54Mbps in 802.11g, 150Mbps in 802.11n and 433.3bps in 802.11ac.
- Switch diversity used for DSSS/CCK
- Support STBC Receiving
- Support LDPC Transmitting
- Hardware antenna diversity
- Fast receiver Automatic Gain Control (AGC)
- On-chip ADC and DAC
- Build-in both 2.4GHz and 5GHz PA
- Build-in both 2.4GHz and 5GHz LNA

Bluetooth Controller

- Compatible with Bluetooth 2.1+EDR
- Support Bluetooth 4.2 system
- Integrated MCU to execute Bluetooth protocol stack
- Supports all packet types in basic rate and enhanced data rate
- Supports piconets in a scatternet
- Supports Low Power Mode (Sniff/Sniff Sub-rating)
- Enhanced BT/WIFI Coexistence Control to improve transmission quality in different profiles
- Bluetooth 4.0 Dual Mode support: Simultaneous LE and BR/EDR

- Supports Secure Simple Pairing
- Supports multiple Low Energy states

Bluetooth Transceiver

- Fast AGC control to improve receiving dynamic range
- Supports Enhanced Power Control
- Supports AFH to dynamically detect channel quality to improve transmission quality
- Supports Bluetooth Low Energy
- Integrated internal Class 1, Class 2, and Class 3 PA
- Integrated 32K oscillator for power management

3. General Specification

Major Chipset	Realtek RTL8821CU
Standard	WIFI: 802.11a/b/g/n/ac/e/i/h BT : V2.1+ EDR and V4.2, For BR/EDR,V4.0BLE
Bus Interface	WiFi: USB2.0 BT: USB2.0
Modulation Method	DSSS,DBPSK, DQPSK, CCK and OFDM (BPSK, QPSK, 16QAM, 64QAM and 256-QAM)
Frequency Band	2.4GHz ~ 2.484 GHz 4.9GHz ~ 6.0GHz
Operating Channel	WiFi 2.4GHz: 11: (Ch. 1-11) – United States 13: (Ch. 1-13) – Europe 14: (Ch. 1-14) – Japan BT 2.4GHz: Ch. 0 ~78
OS Support	Linux/Android/Windows32,64
Security	WMM, WPA, WPA2
Operating Temperature	0 ~ +60° C ambient temperature
Storage Temperature	-20 ~ 70°C ambient temperature
Humidity	5 to 90 % maximum (non-condensing)
Dimension	12.9x 12.2 x 1.6mm (LxWxH) ±0.2MM

4. DC Characteristics

1) Power Supply Characteristics

Symbol	Parameter	Minimum	Typical	Maximum	Units
VDD33	3.3V I/O Supply Voltage	3.0	3.3	3.6	V
VD10	1.05V Core Supply Voltage	0.945	1.05	1.155	V

2) DC Characteristics

Module	Voltage	Current Consumption (linking)
RL-UM02WBS-8821CU-V1.0	2.4G	(上网或者看电影时的功耗)
	5G	(上网或者看电影时的功耗)

5. Electrical Specifications

1) RF Characteristics for IEEE802.11b (11Mbps mode unless otherwise specified)

Items	Contents			
Specification	IEEE802.11b			
Mode	CCK 11 Mbps			
Channel frequency	2412 ~ 2484 MHz			
RX (per \leq 85 dBm@8%)	-85 dBm			
TX Characteristics	Min.	Typ.	Max.	Unit
Power Level (\pm 2 dBm)		17		dBm
EVM (\leq -18)		-18		dB

2) RF Characteristics for IEEE802.11g (54Mbps mode unless otherwise specified)

Items	Contents			
Specification	IEEE802.11g			
Mode	OFDM 54 Mbps			
Channel frequency	2412 ~ 2484 MHz			
RX (per \leq 70 dBm@10%)	-70 dBm			
TX Characteristics	Min.	Typ.	Max.	Unit
Power Level (\pm 2dBm)		14		dBm
EVM (\leq -25)		-28		dB

3) RF Characteristics for IEEE802.11n (BW20_MCS7)

Items	Contents			
Specification	IEEE802.11n (BW20_MCS7)			
Mode	OFDM 65 Mbps			
Channel frequency	2412 ~ 2484 MHz			
RX (per \leq 65 dBm@10%)	-65 dBm			
TX Characteristics	Min.	Typ.	Max.	Unit
Power Level (\pm 2 dBm)		13		dBm
EVM (\leq -28)		-28		dB

4) RF Characteristics for IEEE802.11n (BW40_MCS7)

Items	Contents			
Specification	IEEE802.11n (BW40_MCS7)			
Mode	OFDM 135 Mbps			
Channel frequency	2412 ~ 2484 MHz			
RX (per \leq 65 dBm@10%)	-65 dBm			
TX Characteristics	Min.	Typ.	Max.	Unit
Power Level (\pm 2 dBm)		13		dBm
EVM (\leq -28)		-28		dB

5) RF Characteristics for IEEE802.11ac (BW40_MCS7)

Items	Contents			
Specification	IEEE802.11ac (BW40_MCS7)			
Channel frequency	4.9GHz ~ 6.0GHz			
RX (per≤61 dBm@10%)	-60 dBm			
Freq.Error(±10ppm)	±10ppm			
TX Characteristics	Min.	Typ.	Max.	Unit
Power Level (±2 dBm)		11		dBm
EVM (≤-30)		-30		dB

6) RF Characteristics for IEEE802.11ac (BW80_MCS9)

Items	Contents			
Specification	IEEE802.11ac (BW80_MCS9)			
Channel frequency	4.9GHz ~ 6.0GHz			
RX (per≤59 dBm@10%)	-57 dBm			
Freq.Error(±10ppm)	±10ppm			
TX Characteristics	Min.	Typ.	Max.	Unit
Power Level (±2 dBm)		11		dBm
EVM (≤-32)		-32		dB

6. Bluetooth Specification

Feature	Description		
General Specification			
Bluetooth Standard	Bluetooth V3.3 of 1, 2 and 3 Mbps.		
Host Interface	USB 2.0		
Antenna Reference	Small antennas with 0~2 dBi peak gain		
Frequency Band	2.400 GHz ~ 2483.5 GHz		
Number of Channels	79 channels		
Modulation	FHSS, GFSK, DPSK, DQPSK		
RF Specification			
	Min	Typical	Max
Output Power (Class 1.5)	-6	8	10
Output Power (Class 2)		2	
Sensitivity @ BER=0.1% for GFSK (1Mbps)		-89	
Sensitivity @ BER=0.01% for $\pi/4$ -DQPSK (2Mbps)		-85	
Sensitivity @ BER=0.01% for 8DPSK		-83	

(3Mbps)			
Maximum Input Level	GFSK (1Mbps):-20dBm		
	$\pi/4$ -DQPSK (2Mbps) :-20dBm		
	8DPSK (3Mbps) :-20dBm		

7. Pin Definition

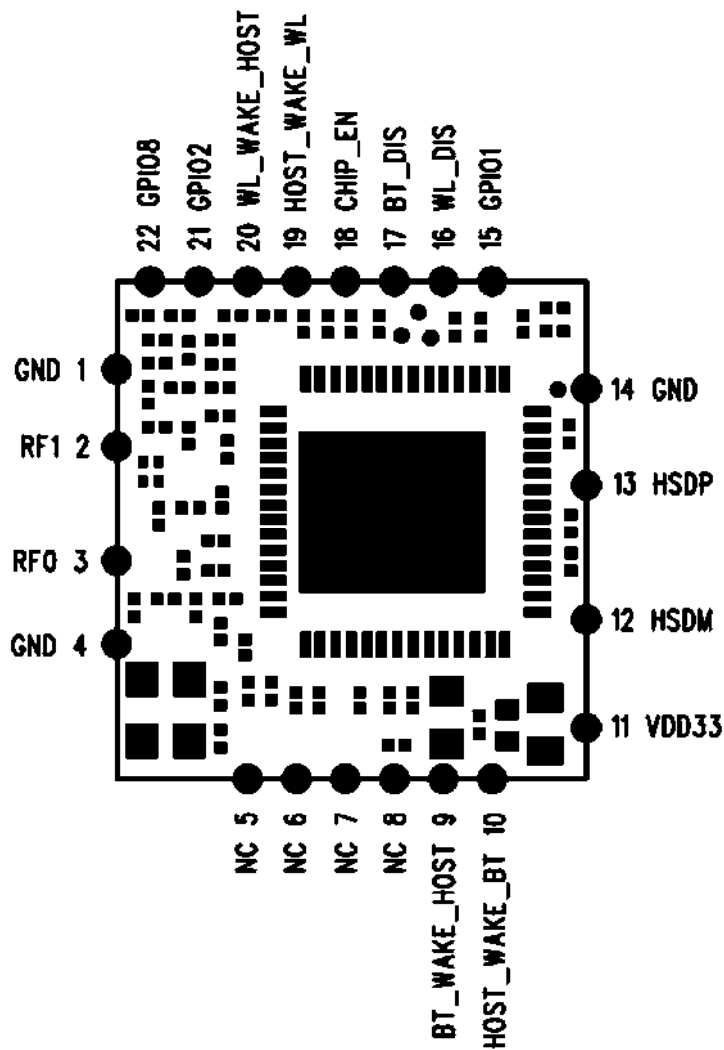

Pin	Definition	Description
1	GND	GND
2	RF1	WIFI 2.4G ANT /BT&5G ANT
3	RF0	NC
4	GND	GND

5~8	NC	NC
9	BT_WAKE_HOST	GPIO14
10	HOST_WAKE_BT	GPIO13
11	VDD33	3.3V
12	HSDM	High-Speed USB D- Signal
13	HSDP	High-Speed USB D+ Signal
14	GND	GND
15	GPIO1	PCM data Out, shared with GPIO1
16	WL_DIS	Shared with GPIO9. This pin can externally shut down the RTL8821CU-CG WLAN function when WL_DIS# is pulled low. When this pin is pulled low, USB interface will be disabled. This pin can also be configured as the WLAN Radio-off function with host interface remaining connected.
17	BT_DIS	Shared with GPIO11. This pin can externally shut down the RTL8821CU-CG BT function when BT_DIS# is pulled Low. When this pin is pulled low, USB interface will be also disabled. This pin can be also defined as the BT Radio-off function with host interface remaining connected.
18	CHIP_EN	This Pin Can externally shut down the RTL8821CU-CG (No Extra Power Switch Required). When this function is not required, external pull high is required
19	HOST_WAKE_WL	GPIO7
20	WL_WAKE_HOST	GPIO6
21	GPIO2	PCM Synchronization control, shared with GPIO2
22	GPIO8	GPIO8

PIN1

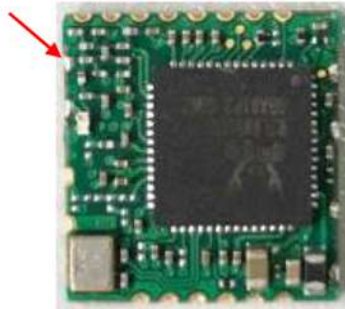

The picture of top

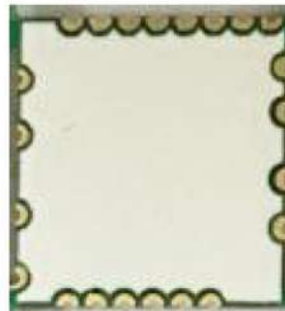

The picture of bottom

8. Size reference

Dimensions (mm)	Length	Width	Height
	12.9	12.2	1.6
	(Tolerance:±0.2mm)	(Tolerance:±0.2mm)	(Tolerance:±0.2mm)

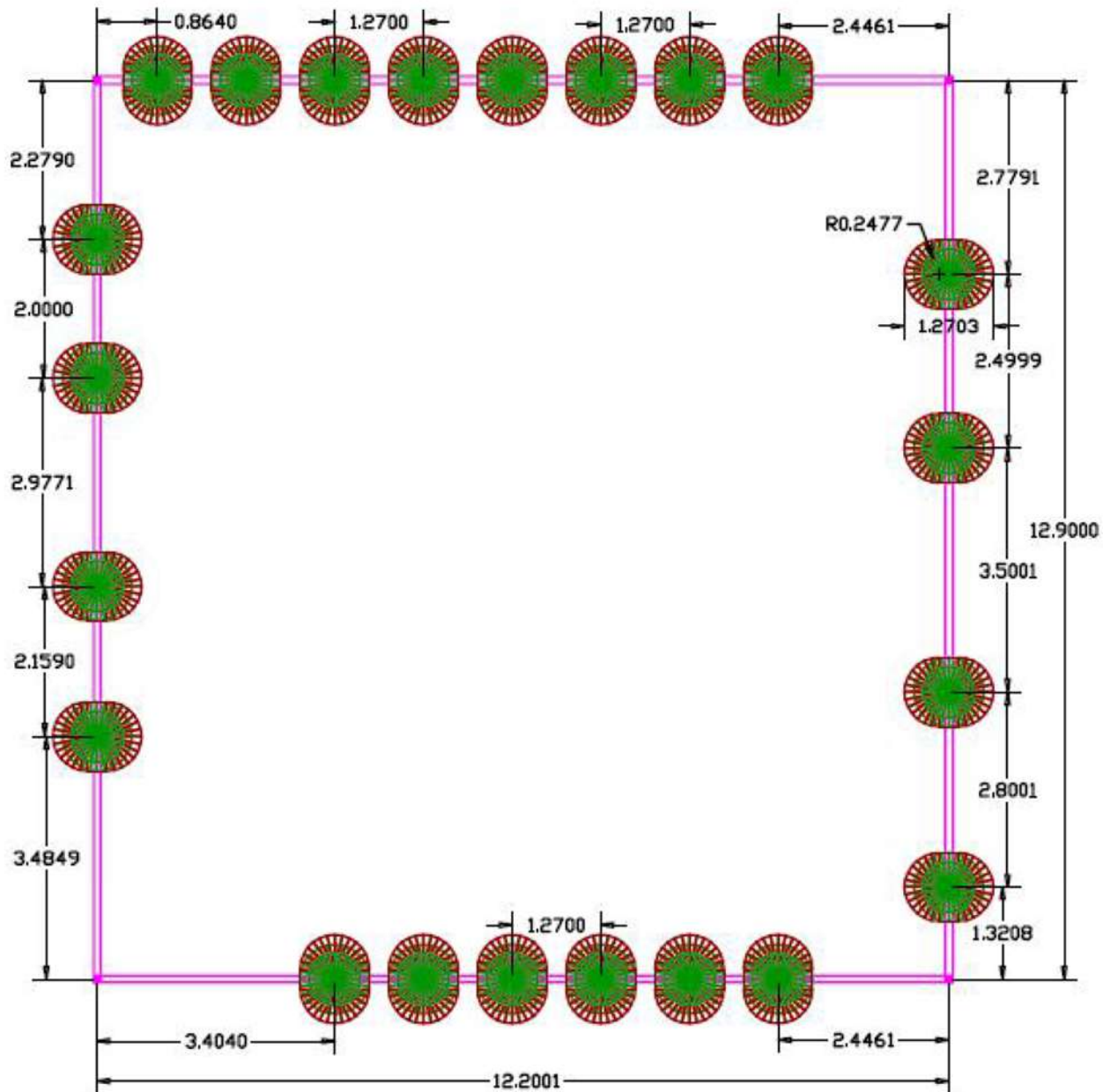

The PCB tolerances within + / -0.2 or so

9.WIFI RF Circuit reference pictures

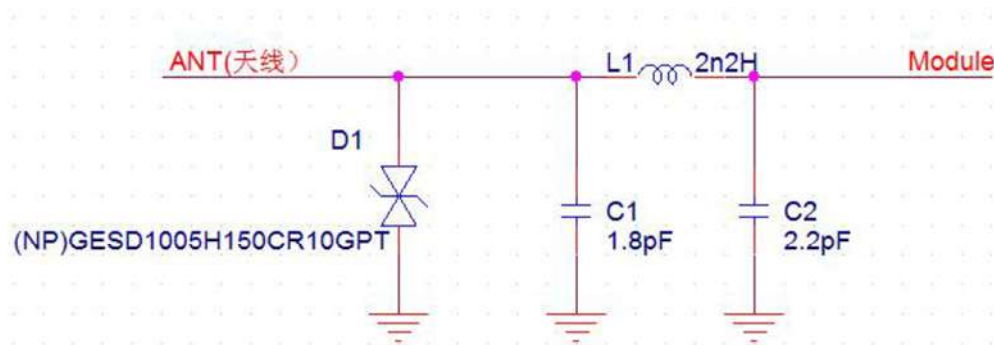

1. Above the dotted box part of the antenna matching is needed, the actual antenna matching electronic parameters shall prevail.

2.For RF part layout to do 50 ohm impedance. can't go on 90° of layout .The line length can't more than 20 mm.

注明：请一定要在焊天线端加一个 TVS 管，防止 ESD 静电打坏 WIFI 模组（如上图参考电路）。

10.USB interface electrical characteristics

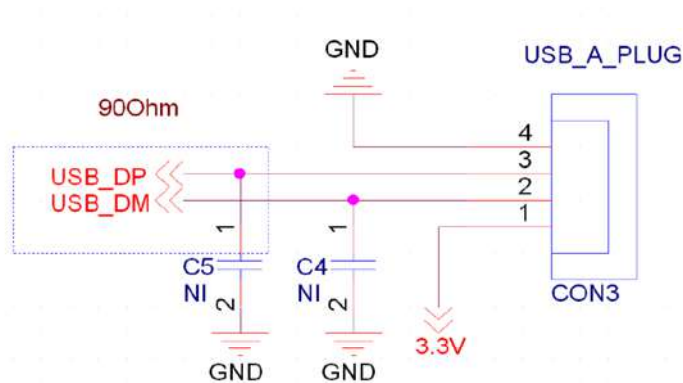

注：1.USB 数据线需要做 90Ohm 的阻抗。

2.建议电源输入端留一个电源开关，每次开关卡时可以做一个上电断电的作用
可以使用 wifi 复位，就不会有打不开 wifi 的错误现象出现。

Note:1.Two root go line do difference , but also required to make 90Ohm the impedance test.e get lock can do

2.Suggested that leave a power switch power supply input terminal ,every tim a electric power is on

11. Recommended Reflow Profile

Referred to IPC/JEDEC standard.

Peak Temperature : $<250^{\circ}\text{C}$

Number of Times : ≤ 2 times

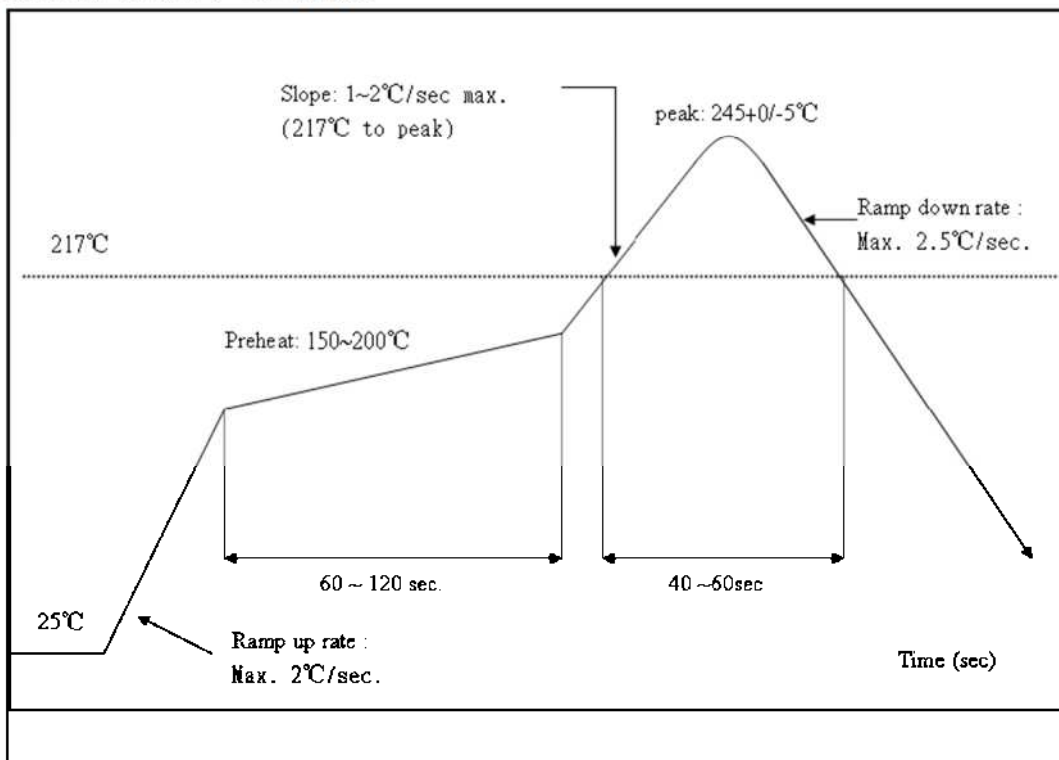

ENVIRONMENTAL

Operating

Operating Temperature: 0°C to $+60^{\circ}\text{C}$

Relative Humidity: 5-90% (non-condensing)

Storage

Temperature: -20°C to $+70^{\circ}\text{C}$ (non-operating)

Relevant Humidity: 5-95% (non-condensing)

12. RoHS compliance.

This product is RoHS compliance.

13. Wireless module before the SMT note:

1. When customers Open stencil must be sure the hole bigger to the Wireless module plate, please press 1 to 1 and 0.7 mm is widened to open outward, the thickness of 0.12 mm.

2. Can't get the wifi module bare hands when needs, must we wear the gloves and static ring.

3. The furnace temperature according to the size of the customer the mainboard, generally like to stick on a tablet standard temperature of 250 + - 5, can do 260 + - 5.

Storage and use Wifi module control should pay attention to the following matters:

1. Module of the storage life of vacuum packaging:

1-1. Storage life: 12 months. Storage conditions: <40°C. Relative humidity: <90%R.H.

1-2. After this bag is opened, devices that will be subjected to infrared reflow, vWIFI or phase reflow, or equivalent processing must be:

1-3. Check the humidity card: stored at $\cong 20\%$ R.H. If: 30%~40%(pink) or greater than 40%(red). Labeling module has moisture absorption.

① Mouthed within 168 hours at factory conditions of: $t \cong 30^\circ\text{C}$, $\cong 60\%$ R.H.

② Once opened, the workshop the preservation of life for 168 hours.

1-4. If baking is required, devices may be baked for:

① Modules must be to remove module moisture problem.

② Baking temperature: 125 °C, 8 hours.

③ After baking, put proper amount of desiccant to seal packages.

1-5. The actual number of module vacuum packing which is based on the actual number of packages to the customer requirements.

2. Module reel packaging items as follows.

2-1. Storage life: 12 months. Storage conditions: <40°C. Relative humidity: <90%R.H.

2-2. Module WIFI art packing after 168 hours, To launch patch need to bake, to remove the module hygroscopic, baking temperature conditions: 125°C, 8 hours.

2-3. The actual number of module reel packing which is based on the actual number of packages to the customer requirements.

3. Module pallet packaging items as follows:

3-1. Storage life: 3 months. Storage conditions: <40°C. Relative humidity: <90%R.H.

3-2. Module if not used within 48 hours, before launch the need for baking, baking temperature: 125 °C, 8 hours.

3-3. Pallet packaging each plate is 100 PCS. The actual number of module pallet packing which is based on the actual number of packages to the customer requirements.

13. Wifi 模块贴片装机前注意事项:

1. 客户在开钢网时一定要将 wifi 模块焊盘的孔开大, 请按 1 比 1 再向外扩大 0.7mm 比例开钢网, 厚度按 0.12mm.

2. 有需要拿 wifi 模块时不可以光手去拿, 一定要戴上手套以及静电环.

3. 过炉温度要根据客户主板的大小而定, 一般像平板电脑上的标准温度为 250+/-5°, 也可以做到 260+/-5°

Wifi 模块储存及使用管制应注意事项如下:

1. 模块的真空包装之储存期限:

1-1. 保存期限: 12 个月, 储存环境条件: 温度在: <40°C, 相对湿度: <90%R.H.

1-2. 模块包装被拆后, SMT 组装之时限:

1-3. 检查湿度卡: 显示值应小于 30% (蓝色), 如: 30%~40% (粉红色) 或者大于 40% (红色) 表示模块已吸湿气.

① 工厂环境温度湿度管制: $\cong 30^\circ\text{C}$, $\cong 60\%$ R.H.

② 拆封后, 车间的保存寿命为 168 小时.

1-4. 如在拆封后的 168 个小时内未使用完, 需要烘烤, 烘烤条件如下:

① 模块须重新烘烤, 以除去模块吸湿问题.

② 烘烤温度条件: 125°C, 8 小时.

③ 烘烤后, 放入适量的干燥剂再密封包装.

1-5. 模块真空包装数量以客户要求的实际包装数量为准.

2. 模块卷盘包装事项如下:

2-1. 保存期限: 12 个月, 储存环境条件: 温度在: <40°C, 相对湿度: <90%R.H.

2-2. 模块拆开包装 168 小时后, 如要上线贴片需要重新烘烤, 以除去模块吸湿问题, 烘烤温度条件: 125°C, 8 小时.

2-3. 模块卷盘包装以客户要求的实际包装数量为准.

3. 模块托盘包装事项如下:

3-1. 保存期限: 3 个月, 储存环境条件: 温度在: <40°C, 相对湿度: <90%R.H.

3-2. 模块如在 48 小时内未使用, 在上线之前需要进行烘烤, 烘烤温度条件: 125°C, 8 小时.

3-3. 托盘包装每盘为 100pcs, 模块托盘包装以客户要求的实际包装数量为准.

注: 以上包装方式根据客户要求而定, 包装以实际出货为准.

Federal Communication Commission Interference Statement

This equipment has been tested and found to comply with the limits for a Class B digital device, pursuant to Part 15 of the FCC Rules. These limits are designed to provide reasonable protection against harmful interference in a residential installation. This equipment generates, uses, and can radiate radio frequency energy and, if not installed and used in accordance with the instructions, may cause harmful interference to radio communications. However, there is no guarantee that interference will not occur in a particular installation. If this equipment does cause harmful interference to radio or television reception, which can be determined by turning the equipment off and on, the user is encouraged to try to correct the interference by one or more of the following measures:

- Reorient or relocate the receiving antenna.
- Increase the separation between the equipment and receiver.
- Connect the equipment into an outlet on a circuit different from that to which the receiver is connected.
- Consult the dealer or an experienced radio/TV technician for help.

FCC Caution (15.19 statement)

This device complies with Part 15 of the FCC Rules. Operation is subject to the following two conditions: (1) This device may not cause harmful interference, and (2) this device must accept any interference received, including interference that may cause undesired operation.

Non-modification Statement:

Changes or modifications not expressly approved by the party responsible for compliance could void the user's authority to operate the equipment.

FCC Radiation Exposure Statement:

This equipment complies with FCC radiation exposure limits set forth for an uncontrolled environment. This equipment should be installed and operated with minimum distance 20cm between the radiator & your body.

Validity of using the module certification:

In the event that these conditions cannot be met (for example certain laptop configurations or co-location with another transmitter), then the FCC authorization for this module in combination with the host equipment is no longer considered valid and the FCC ID of the module cannot be used on the final product. In these circumstances, the OEM integrator will be responsible for re-evaluating the end product (including the transmitter) and obtaining a separate FCC authorization.

Custom design antennas may be used, however the OEM installer must following the FCC 15.21 requirements and verify if new FCC approval will be necessary.

End product labeling:

This transmitter module is authorized only for use in device where the antenna may be installed such that 20 cm may be maintained between the antenna and users. The final end product must be labeled in a visible area with the following: "Contains FCC ID: GSS-VS17337".

Information that must be placed in the end user manual:

The OEM integrator has to be aware not to provide information to the end user regarding how to install or remove this RF module in the user's manual of the end product which integrates this module. The end user manual shall include all required regulatory information/warning as show in this manual.

Co-location warning:

This transmitter must not be co-located or operating in conjunction with any other antenna or transmitter.

OEM integration instructions:

This device is intended only for OEM integrators under the following conditions:

The antenna must be installed such that 20 cm is maintained between the antenna and users, and the transmitter module may not be co-located with any other transmitter or antenna. The module shall be only used with the external antenna(s) that has been originally tested and certified with this module.

For all products market in US, OEM has to limit the operation channels in Channel 1 to Channel 11 or 3-9 as specified above by the supplied firmware programming tool. OEM shall not supply any tool or info to the end-user regarding to Regulatory Domain change.

As long as 3 conditions above are met, further transmitter test will not be required. However, the OEM integrator is still responsible for testing their end-product for any additional compliance requirements required with this module installed (for example, digital device emissions, PC peripheral requirements, etc.).

Important Notes:

The OEM integrator has to be aware not to provide information to the end user regarding how to install or remove this RF module in the user's manual of the end product which integrates this module. The end user manual shall include all required regulatory information/warning as show in this manual.