



90mm

4pt

3.2pt

40mm



4.5pt

40\*11mm

UJ9 YYWW XXXX  
 UJ9 = Regional Product ID  
 YY = Last 2 digits of manufacturing year  
 WW = Manufacturing week  
 XXXXX = Serial No.: 00001~99999 (restart every week)

Panel Code

IX=Innolux	CI=CMI
AO=AUO	CT=CPT
BE=BOE	LD=LGD
HR=Hannstar	MD=MTD/I/O
SG=Samsung	SP=Sharp
TA=Tianmma	PA=PANDA

REVISIONS			
LTR	DESCRIPTION	DATE	APP
3A			
			
			

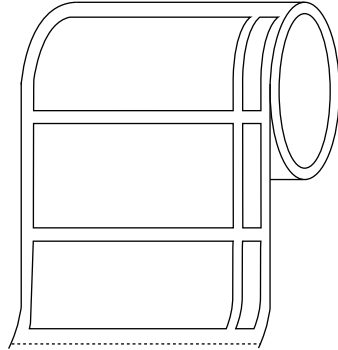

1	HCU1001010	RATING LABEL PL.U11A(HCU1001.R3A)							
ITEM	PART NO.	DESCRIPTION							
Quanta Computer Inc.					MODEL				
					U11A				
RANGE	TOLERANCE	NAME	RATING LABEL PL.U11A			APPROVED			
0-10	±0.10	TOL.±	1 PLC	2 PLC	ANGLE	UNIT	MM	DESIGNED	KENT
10-50	±0.15	MATERIAL	50#不变色反银龙+25#可打印雾P			SCALE	1:1	DRAWN	KENT
50-100	±0.20	FINISH				DATE	2013-05-02	REV.	3A
100-	±0.25	A4	 THIRD ANGLE PROJECTION			DWG.NO.	HCU1001	1/1	