



# FCC REPORT

**Applicant:** ViewSonic Corporation  
**Address of Applicant:** 381 Brea Canyon Road, Walnut, CA 91789, USA  
**Equipment Under Test (EUT)**  
Product Name: Tablet PC  
Model No.: VS14140  
**FCC ID:** GSS-VS14140  
**Applicable standards:** FCC CFR Title 47 Part 2: 2010  
FCC CFR Title 47 Part22 Subpart H: 2010  
FCC CFR Title 47 Part24 Subpart E: 2010  
**Date of sample receipt:** 17 Jun., 2011  
**Date of Test:** 17-28 Jun., 2011  
**Date of report issued:** 29 Jun., 2011  
**Test Result :** Pass \*

\* In the configuration tested, the EUT complied with the standards specified above.

Authorized Signature:

Robinson Lo  
Laboratory Manager

This report details the results of the testing carried out on one sample. The results contained in this test report do not relate to other samples of the same product and does not permit the use of the GTS product certification mark. The manufacturer should ensure that all products in series production are in conformity with the product sample detailed in this report.

This report may only be reproduced and distributed in full. If the product in this report is used in any configuration other than that detailed in the report, the manufacturer must ensure the new system complies with all relevant standards. Any mention of GTS International Electrical Approvals or testing done by GTS International Electrical Approvals in connection with, distribution or use of the product described in this report must be approved by GTS International Electrical Approvals in writing.

This document cannot be reproduced except in full, without prior written approval of the Company. Any unauthorized alteration, forgery or falsification of the content or appearance of this document is unlawful and offenders may be prosecuted to the fullest extent of the law. Unless otherwise stated the results shown in this test report refer only to the sample(s) tested and such sample(s) are retained for 90 days only."

## 2 Version

| Version No. | Date       | Description |
|-------------|------------|-------------|
| 00          | 2011-06-29 | Original    |
|             |            |             |
|             |            |             |
|             |            |             |
|             |            |             |

Prepared By: Collin He Date: 2011-06-29  
Project Engineer

Check By: Hans.Hu Date: 2011-06-29  
Reviewer

## 3 Contents

|   | Page      |
|---|-----------|
| <b>1 COVER PAGE</b> .....                                 | <b>1</b>  |
| <b>2 VERSION</b> .....                                    | <b>2</b>  |
| <b>3 CONTENTS</b> .....                                   | <b>3</b>  |
| <b>4 TEST SUMMARY</b> .....                               | <b>5</b>  |
| <b>5 GENERAL INFORMATION</b> .....                        | <b>6</b>  |
| 5.1 CLIENT INFORMATION .....                              | 6         |
| 5.2 GENERAL DESCRIPTION OF E.U.T.....                     | 6         |
| 5.3 RELATED SUBMITTAL(S) / GRANT (S) .....                | 6         |
| 5.4 TEST METHODOLOGY .....                                | 6         |
| 5.5 TEST FACILITY.....                                    | 7         |
| 5.6 TEST LOCATION.....                                    | 7         |
| 5.7 TEST INSTRUMENTS LIST.....                            | 8         |
| <b>6 SYSTEM TEST CONFIGURATION</b> .....                  | <b>9</b>  |
| 6.1 EUT CONFIGURATION .....                               | 9         |
| 6.2 EUT EXERCISE .....                                    | 9         |
| 6.3 TEST PROCEDURE .....                                  | 9         |
| 6.3.1 Conducted Emissions.....                            | 9         |
| 6.3.2 Radiated Emissions.....                             | 9         |
| 6.4 CONFIGURATION OF TESTED SYSTEM .....                  | 9         |
| 6.5 DESCRIPTION OF TEST MODES.....                        | 10        |
| <b>7 RF POWER OUTPUT MEASUREMENT</b> .....                | <b>11</b> |
| 7.1 STANDARD APPLICABLE .....                             | 11        |
| 7.2 TEST SETUP .....                                      | 11        |
| 7.3 MEASUREMENT PROCEDURE .....                           | 11        |
| 7.4 TEST RESULT .....                                     | 11        |
| <b>8 ERP, EIRP MEASUREMENT</b> .....                      | <b>12</b> |
| 8.1 STANDARD APPLICABLE .....                             | 12        |
| 8.2 TEST SET-UP (BLOCK DIAGRAM OF CONFIGURATION).....     | 12        |
| 8.3 MEASUREMENT PROCEDURE .....                           | 13        |
| 8.4 MEASUREMENT RESULT .....                              | 14        |
| <b>9 MODULATION CHARACTERISTIC</b> .....                  | <b>16</b> |
| <b>10 OCCUPIED BANDWIDTH</b> .....                        | <b>17</b> |
| 10.1 STANDARD APPLICABLE .....                            | 17        |
| 10.2 TEST SETUP.....                                      | 17        |
| 10.3 TEST PROCEDURE .....                                 | 17        |
| 10.4 TEST RESULT .....                                    | 17        |
| <b>11 OUT OF BAND EMISSION AT ANTENNA TERMINALS</b> ..... | <b>21</b> |
| 11.1 STANDARD APPLICABLE .....                            | 21        |
| 11.2 TEST SETUP.....                                      | 21        |

|           |   |           |
|-----------|---|-----------|
| 11.3      | MEASUREMENT PROCEDURE .....                                   | 21        |
| 11.4      | MEASUREMENT RESULT .....                                      | 22        |
| 11.4.1    | <i>Spurious emission</i> .....                                | 22        |
| 11.4.2    | <i>Band edge emission</i> .....                               | 25        |
| <b>12</b> | <b>FIELD STRENGTH OF SPURIOUS RADIATION MEASUREMENT .....</b> | <b>27</b> |
| 12.1      | STANDARD APPLICABLE .....                                     | 27        |
| 12.2      | EUT SETUP (BLOCK DIAGRAM OF CONFIGURATION) .....              | 27        |
| 12.3      | MEASUREMENT PROCEDURE .....                                   | 28        |
| 12.4      | TEST RESULT .....   | 29        |
| <b>13</b> | <b>FREQUENCY STABILITY V.S. TEMPERATURE MEASUREMENT .....</b> | <b>35</b> |
| 13.1      | STANDARD APPLICABLE .....                                     | 35        |
| 13.2      | TEST SETUP .....  | 35        |
| 13.3      | TEST PROCEDURE .....  | 35        |
| 13.4      | TEST RESULT .....   | 36        |
| <b>14</b> | <b>FREQUENCY STABILITY V.S. VOLTAGE MEASUREMENT .....</b>     | <b>37</b> |
| 14.1      | STANDARD APPLICABLE .....                                     | 37        |
| 14.2      | TEST SETUP .....  | 37        |
| 14.3      | TEST PROCEDURE .....  | 37        |
| 14.4      | TEST RESULT .....   | 38        |
| <b>15</b> | <b>AC POWER LINE CONDUCTED EMISSION TEST .....</b>            | <b>39</b> |
| 15.1      | STANDARD APPLICABLE .....                                     | 39        |
| 15.2      | TEST SETUP .....  | 39        |
| 15.3      | TEST PROCEDURE .....  | 39        |
| 15.4      | MEASUREMENT RESULT .....                                      | 39        |
| <b>16</b> | <b>TEST SETUP PHOTO .....</b>                                 | <b>44</b> |
| <b>17</b> | <b>EUT CONSTRUCTIONAL DETAILS .....</b>                       | <b>46</b> |

## 4 Test Summary

| Test Item                              | Section in CFR 47                                    | Result                                  |
|--|--|---|
| RF Exposure (SAR)                      | Part 1.1307<br>Part 2.1093                           | Passed*<br>(Please refer to SAR Report) |
| RF Output Power                        | Part 2.1046<br>Part 22.913 (a)(2)<br>Part 24.232 (c) | Pass                                    |
| Modulation Characteristics             | Part 2.1047  | Pass                                    |
| 99% & -26 dB Occupied Bandwidth        | Part 2.1049<br>Part 22.917<br>Part 24.238            | Pass                                    |
| Spurious Emissions at Antenna Terminal | Part 2.1051<br>Part 22.917 (a)<br>Part 24.238 (a)    | Pass                                    |
| Field Strength of Spurious Radiation   | Part 2.1053<br>Part 22.917 (a)<br>Part 24.238 (a)    | Pass                                    |
| Out of band emission, Band Edge        | Part 22.917 (a)<br>Part 24.238 (a)                   | Pass                                    |
| Frequency stability vs. temperature    | Part 2.1055(a)(1)(b)                                 | Pass                                    |
| Frequency stability vs. voltage        | Part 2.1055(d)(1)(2)                                 | Pass                                    |

## 5 General Information

### 5.1 Client Information

|                          |  |
|--------------------------|--|
| Applicant:               | ViewSonic Corporation  |
| Address of Applicant:    | 381 Brea Canyon Road, Walnut, CA 91789, USA  |
| Manufacturer:            | ViewSonic Corporation  |
| Address of Manufacturer: | 381 Brea Canyon Road, Walnut, CA 91789, USA  |
| Factory:                 | Topstar Overseas Electronics Co., Ltd.   |
| Address of Factory:      | 4-7/F, Building B, ChengChengFa Industrial Zone, Shenzhen export Processing Zone, PingShan new District, Shenzhen, China |

### 5.2 General Description of E.U.T.

|                      |   |
|----------------------|---|
| Product Name:        | Tablet PC   |
| Model No.:           | VS14140   |
| Power supply:        | Input: AC 100-240V 50/60Hz 0.7A<br>Output: DC 12V 1.5A        |
| Operation Frequency: | WCDMA Band II: 1850MHz~1910MHz<br>WCDMA Band V: 824MHz~849MHz |
| Type of Emission:    | 4M20KG7W  |

### 5.3 Related Submittal(s) / Grant (s)

This submittal(s) (test report) is filing to comply with Section Part 22 subpart H and Part 24 subpart E of the FCC CFR 47 Rules.

### 5.4 Test Methodology

Both conducted and radiated testing were performed according to the procedures document on chapter 13 of ANSI C63.4 (2003) and FCC CFR 47.1046, 2.1047, 2.1049, 2.1051, 2.1053, 2.1055 and 2.1057

## 5.5 Test Facility

The test facility is recognized, certified, or accredited by the following organizations:

- FCC —Registration No.: 600491

Global United Technology Services Co., Ltd., Shenzhen EMC Laboratory has been registered and fully described in a report filed with the (FCC) Federal Communications Commission. The acceptance letter from the FCC is maintained in files. Registration 600491, July 20, 2010.

- Industry Canada (IC)

The 3m Semi-anechoic chamber of Global United Technology Services Co., Ltd. has been Registered by Certification and Engineering Bureau of Industry Canada for radio equipment testing with Registration No.: 9079A-1.

## 5.6 Test Location

All tests were performed at:

Global United Technology Services Co., Ltd.

Address: 2nd Floor, Block No.2, Laodong Industrial Zone, Xixiang Road Baoan District, Shenzhen, China

Tel: 0755-27798480

Fax: 0755-27798960

## 5.7 Test Instruments list

| Radiated Emission: |                                      |                                |                       |               |                     |                         |
|--------------------|--------------------------------------|--------------------------------|-----------------------|---------------|---------------------|-------------------------|
| Item               | Test Equipment                       | Manufacturer                   | Model No.             | Inventory No. | Cal.Date (mm-dd-yy) | Cal.Due date (mm-dd-yy) |
| 1                  | 3m Semi- Anechoic Chamber            | ZhongYu Electron               | 9.2(L)*6.2(W)* 6.4(H) | GTS201        | Mar. 30 2011        | Mar. 29 2012            |
| 2                  | Control Room                         | ZhongYu Electron               | 6.2(L)*2.5(W)* 2.4(H) | GTS202        | N/A                 | N/A                     |
| 3                  | EMI Test Receiver                    | Rohde & Schwarz                | ESU26                 | GTS203        | Sept. 10 2010       | Sept. 09 2011           |
| 4                  | BiConiLog Antenna                    | SCHWARZBECK<br>MESS-ELEKTRONIK | VULB9163              | GTS204        | Feb. 26 2011        | Feb. 25 2012            |
| 5                  | Double -ridged waveguide horn        | SCHWARZBECK<br>MESS-ELEKTRONIK | 9120D-829             | GTS205        | June 30 2010        | June 29 2011            |
| 6                  | EMI Test Software                    | AUDIX                          | E3                    | N/A           | N/A                 | N/A                     |
| 7                  | Coaxial Cable                        | GTS                            | N/A                   | GTS400        | Apr. 01 2011        | Mar. 31 2012            |
| 8                  | Coaxial Cable                        | GTS                            | N/A                   | GTS401        | Apr. 01 2011        | Mar. 31 2012            |
| 9                  | Coaxial cable                        | GTS                            | N/A                   | GTS402        | Apr. 01 2011        | Mar. 31 2012            |
| 10                 | Coaxial Cable                        | GTS                            | N/A                   | GTS407        | Apr. 01 2011        | Mar. 31 2012            |
| 11                 | Coaxial Cable                        | GTS                            | N/A                   | GTS408        | Apr. 01 2011        | Mar. 31 2012            |
| 12                 | Amplifier(10KHz-5GHz)                | Sonnoma Instrument             | 305-1052              | GTS210        | Aug. 03 2010        | Aug. 02 2011            |
| 13                 | Amplifier(2GHz-20GHz)                | HP                             | 8349B                 | GTS231        | Aug. 03 2010        | Aug. 02 2011            |
| 14                 | Universal radio communication tester | Rohde & Schwarz                | CMU200                | GTS235        | May 11 2011         | May 10 2012             |
| 15                 | Signal Generator                     | Rohde & Schwarz                | SML03                 | GTS236        | May 11 2011         | May 10 2012             |
| 16                 | Temp. Humidity/Barometer             | Oregon Scientific              | BA-888                | GTS248        | May 11 2011         | May 10 2012             |
| 17                 | D.C. Power Supply                    | Instek                         | PS-3030               | GTS232        | NA                  | NA                      |
| 18                 | Splitter                             | Agilent                        | 11636B                | GTS237        | May 11 2011         | May 10 2012             |

| Conducted Emission: |                   |                                |                      |               |                     |                         |
|---------------------|-------------------|--------------------------------|----------------------|---------------|---------------------|-------------------------|
| Item                | Test Equipment    | Manufacturer                   | Model No.            | Inventory No. | Cal.Date (mm-dd-yy) | Cal.Due date (mm-dd-yy) |
| 1                   | Shielding Room    | ZhongYu Electron               | 7.0(L)x3.0(W)x3.0(H) | GTS252        | Apr. 10 2011        | Apr. 09 2012            |
| 2                   | EMI Test Receiver | Rohde & Schwarz                | ESCS30               | GTS223        | Sept. 14 2010       | Sept. 13 2011           |
| 3                   | 10dB Pulse Limita | Rohde & Schwarz                | N/A                  | GTS224        | Sept. 14 2010       | Sept. 13 2011           |
| 4                   | LISN              | SCHWARZBECK<br>MESS-ELEKTRONIK | NSLK 8127            | GTS226        | Apr. 14 2011        | Apr. 13 2012            |
| 5                   | Coaxial Cable     | GTS                            | N/A                  | GTS227        | Apr. 01 2011        | Mar. 31 2012            |
| 6                   | EMI Test Software | AUDIX                          | E3                   | N/A           | N/A                 | N/A                     |



## 6 SYSTEM TEST CONFIGURATION

### 6.1 EUT Configuration

The EUT configuration for testing is installed on RF field strength measurement to meet the Commissions requirement and operating in a manner which intends to maximize its emission characteristics in a continuous normal application.

### 6.2 EUT Exercise

The EUT (Transmitter) was operated in the engineering mode to fix the Tx frequency which was for the purpose of the measurements.

### 6.3 Test Procedure

#### 6.3.1 Conducted Emissions

The EUT is placed on a turn table which is 0.8m above ground plane. According to the requirements in Section 7 and 13 of ANSI C63.4-2003. Conducted emissions from the EUT measured in the frequency range between 0.15MHz and 30MHz using CISPR Quasi-Peak and Average detector mode.

#### 6.3.2 Radiated Emissions

The EUT is placed on a turn table which is 1.0m above ground plane. The turn table shall rotate 360 degrees to determine the position of maximum emission level. EUT is set 3m away from the receiving antenna which varied from 1m to 4m to find out the highest emission. And also, each emission was to be maximized by changing the polarization of receiving antenna both horizontal and vertical. In order to find out the max. emission, the relative positions of this hand-held transmitter (EUT) was rotated through three orthogonal axes according to the requirements in Section 8 and 13 of ANSI C63.4-2003.

### 6.4 Configuration of Tested System

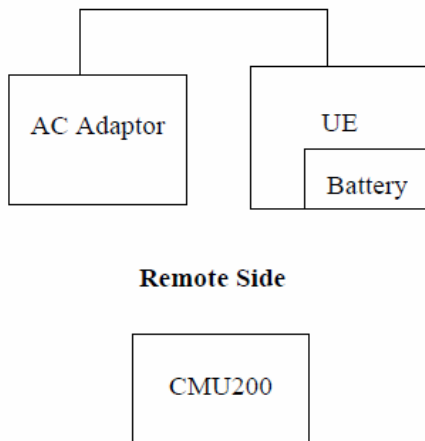

## 6.5 DESCRIPTION OF TEST MODES

The EUT has been tested under operating condition.

EUT staying in continuous transmitting mode. Channel Low, Mid and High for each type band with rated data rate were chosen for full testing.

The field strength of spurious radiation emission was measured as EUT stand-up position (H mode) and lie down position (E1, E2 mode) for both GSM/PCS with power adaptors, earphone and Data cable. The worst-case H mode for GSM 850 band, PCS1900 band.

## 7 RF POWER OUTPUT MEASUREMENT

### 7.1 Standard Applicable

According to FCC Part 2.1046.

FCC 22.913(a)(2) Mobile station are limited to 7W

FCC 24.232(b) Mobile station are limited to 2W.

### 7.2 Test setup

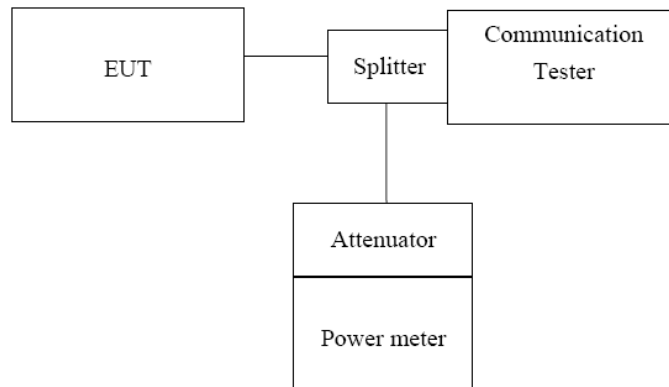

*Note: Measurement setup for testing on Antenna connector*

### 7.3 Measurement Procedure

The transmitter output was connected to a calibrated attenuator, the other end of which was connected to a power meter. Transmitter output was read off the power meter in dBm. The power output at the transmitter antenna port was determined by adding the value of the attenuator to power meter reading.

### 7.4 Test Result

| EUT Mode     | Frequency (MHz) | Channel | PK power (dBm) |
|--------------|-----------------|---------|----------------|
| WCDMA Band V | 826.40          | 4132    | 24.18          |
|              | 836.00          | 4180    | 24.37          |
|              | 846.60          | 4233    | 24.27          |

| EUT Mode      | Frequency (MHz) | Channel | PK power (dBm) |
|---------------|-----------------|---------|----------------|
| WCDMA Band II | 1852.40         | 9262    | 23.58          |
|               | 1880.00         | 9400    | 23.67          |
|               | 1907.60         | 9538    | 23.52          |

## 8 ERP, EIRP MEASUREMENT

### 8.1 Standard Applicable

According to FCC Part 2.1046

FCC 22.913(a) Mobile station are limited to 7W ERP.

FCC 24.232(b) Mobile station are limited to 2W EIRP.

### 8.2 Test SET-UP (Block Diagram of Configuration)

(A) Radiated Emission Test Set-Up, Frequency Below 1000MHz

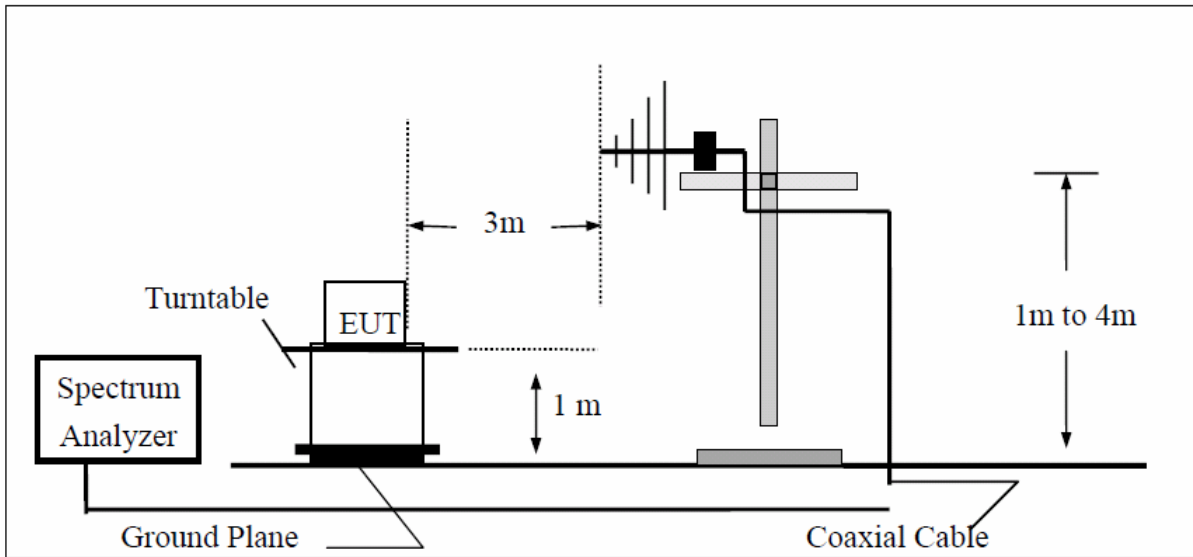

(B) Radiated Emission Test Set-UP Frequency Over 1 GHz

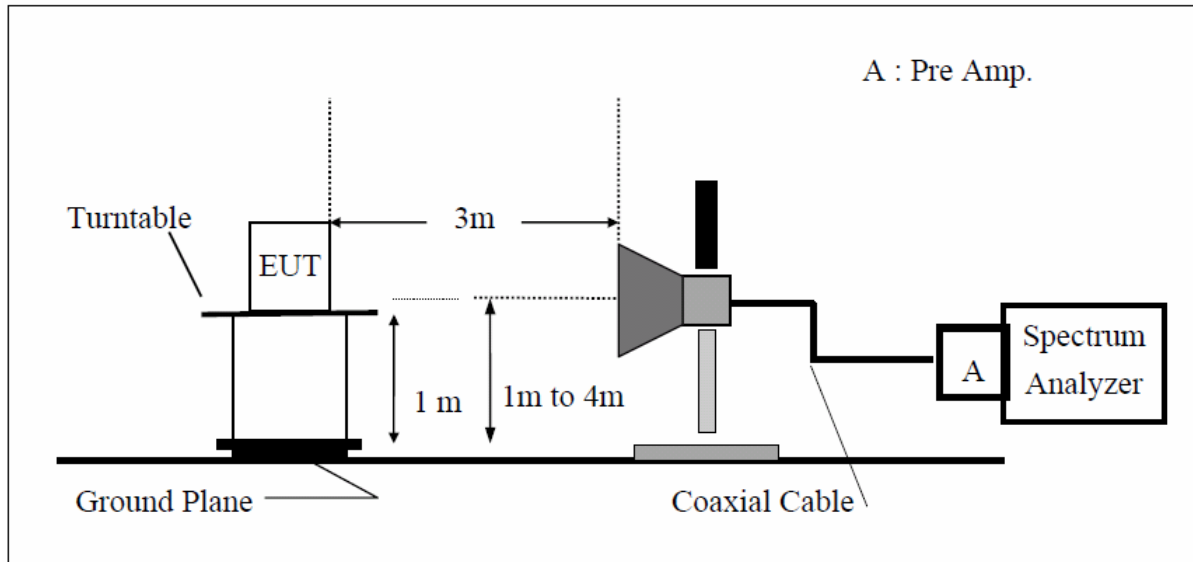

(C) Substituted Method Test Set-UP

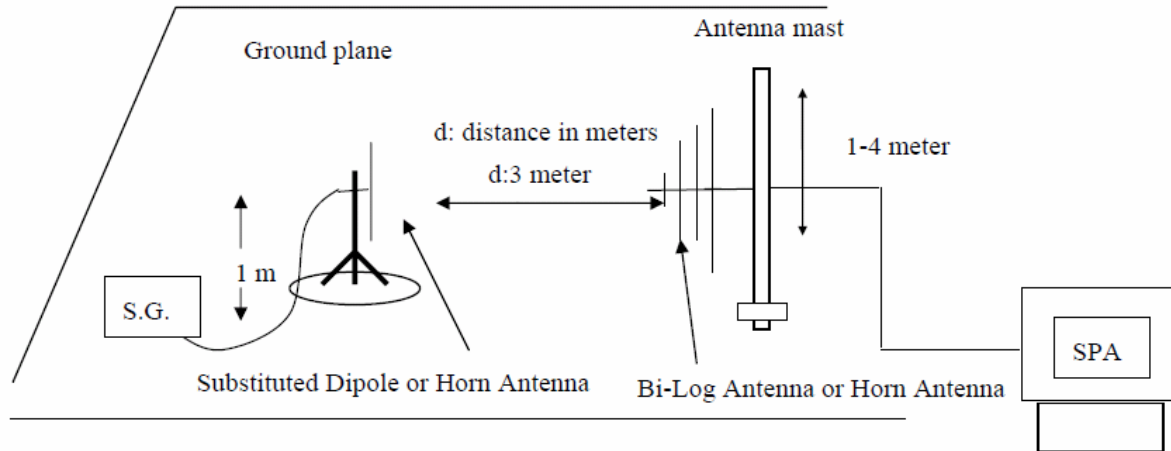

### 8.3 Measurement Procedure

The EUT was placed on an non-conductive turntable using a non-conductive support. The radiated emission at the fundamental frequency was measured at 3 m with a test antenna and EMI spectrum analyzer.

During the measurement, the EUT was communication with the station. The highest emission was recorded with the rotation of the turntable and the lowering of the test antenna from 4m to 1m. The reading was recorded and the field strength (E in dBuV/m) was calculated.

ERP in frequency band 824.2 –848.80.8MHz were measured using a substitution method. The EUT was replaced by dipole antenna connected, the S.G. output was recorded and ERP was calculated as follows:

EIRP in frequency band 1850.2 –1909.8MHz were measured using a substitution method. The EUT was replaced by or horn antenna connected, the S.G. output was recorded and EIRP was calculated as follows:

$$\text{ERP} = \text{S.G. output (dBm)} + \text{Antenna Gain (dBd)} - \text{Cable Loss (dB)}$$

$$\text{EIRP} = \text{S.G. output (dBm)} + \text{Antenna Gain (dBi)} - \text{Cable Loss (dB)}$$

## 8.4 Measurement Result

| EUT mode     | Frequency (MHz) | CH   | EUT Pol. | Antenna Pol. | SPA Reading (dBuV) | S.G. Output (dBm) | Antenna Gain (dBd) | Cable Loss (dB) | ERP (dBm) | Limit (dBm) |
|--------------|-----------------|------|----------|--------------|--------------------|-------------------|--------------------|-----------------|-----------|-------------|
| WCDMA Band V | 826.40          | 4132 | H        | V            | 114.43             | 31.04             | -7.87              | 3.62            | 19.55     | 38.45       |
|              |                 |      |          | H            | 120.09             | 36.82             | -7.87              | 3.62            | 25.33     | 38.45       |
|              |                 |      | E1       | V            | 117.18             | 32.79             | -7.87              | 3.62            | 21.30     | 38.45       |
|              |                 |      |          | H            | 114.73             | 29.46             | -7.87              | 3.62            | 17.97     | 38.45       |
|              |                 |      | E2       | V            | 114.51             | 28.20             | -7.87              | 3.62            | 16.71     | 38.45       |
|              |                 |      |          | H            | 120.14             | 35.87             | -7.87              | 3.62            | 24.38     | 38.45       |
|              | 836.00          | 4180 | H        | V            | 115.02             | 31.77             | -7.88              | 3.65            | 20.24     | 38.45       |
|              |                 |      |          | H            | 119.63             | 37.52             | -7.88              | 3.65            | 25.99     | 38.45       |
|              |                 |      | E1       | V            | 119.34             | 35.09             | -7.88              | 3.65            | 23.56     | 38.45       |
|              |                 |      |          | H            | 117.78             | 29.55             | -7.88              | 3.65            | 18.02     | 38.45       |
|              |                 |      | E2       | V            | 116.18             | 27.93             | -7.88              | 3.65            | 16.40     | 38.45       |
|              |                 |      |          | H            | 123.74             | 35.51             | -7.88              | 3.65            | 23.98     | 38.45       |
|              | 846.60          | 4233 | H        | V            | 120.59             | 33.47             | -7.88              | 3.68            | 21.91     | 38.45       |
|              |                 |      |          | H            | 124.80             | 37.57             | -7.88              | 3.68            | 26.01     | 38.45       |
|              |                 |      | E1       | V            | 122.24             | 36.12             | -7.88              | 3.68            | 24.56     | 38.45       |
|              |                 |      |          | H            | 116.88             | 30.69             | -7.88              | 3.68            | 19.13     | 38.45       |
|              |                 |      | E2       | V            | 115.92             | 29.80             | -7.88              | 3.68            | 18.24     | 38.45       |
|              |                 |      |          | H            | 122.22             | 35.98             | -7.88              | 3.68            | 24.42     | 38.45       |

**Remark :**

- (1) The RBW,VBW of SPA for frequency  
 Below 1GHz was RBW=100 KHz, VBW=300KHz,  
 Above 1GHz was RBW= 1MHz , VBW= 3MHz

| EUT mode      | Frequency (MHz) | CH   | EUT Pol. | Antenna Pol. | SPA Reading (dBuV) | S.G. Output (dBm) | Antenna Gain (dBd) | Cable Loss (dB) | ERP (dBm) | Limit (dBm) |
|---------------|-----------------|------|----------|--------------|--------------------|-------------------|--------------------|-----------------|-----------|-------------|
| WCDMA Band II | 1852.40         | 9262 | H        | V            | 120.37             | 15.98             | 9.90               | 5.56            | 20.32     | 33.00       |
|               |                 |      |          | H            | 124.71             | 20.29             | 9.90               | 5.56            | 24.63     | 33.00       |
|               |                 |      | E1       | V            | 120.00             | 15.61             | 9.90               | 5.56            | 19.95     | 33.00       |
|               |                 |      |          | H            | 123.06             | 18.88             | 9.90               | 5.56            | 23.22     | 33.00       |
|               |                 |      | E2       | V            | 121.94             | 17.55             | 9.90               | 5.56            | 21.89     | 33.00       |
|               |                 |      |          | H            | 124.81             | 19.63             | 9.90               | 5.84            | 23.69     | 33.00       |
|               | 1880.00         | 9400 | H        | V            | 119.01             | 14.65             | 9.99               | 5.61            | 19.03     | 33.00       |
|               |                 |      |          | H            | 124.71             | 20.57             | 9.99               | 5.61            | 24.95     | 33.00       |
|               |                 |      | E1       | V            | 123.79             | 19.43             | 9.99               | 5.61            | 23.81     | 33.00       |
|               |                 |      |          | H            | 123.44             | 19.60             | 9.99               | 5.61            | 23.98     | 33.00       |
|               |                 |      | E2       | V            | 121.50             | 18.14             | 9.99               | 5.61            | 22.52     | 33.00       |
|               |                 |      |          | H            | 127.08             | 20.94             | 9.99               | 5.61            | 25.32     | 33.00       |
|               | 1907.60         | 9538 | H        | V            | 119.23             | 14.90             | 10.08              | 5.66            | 19.32     | 33.00       |
|               |                 |      |          | H            | 123.71             | 20.60             | 10.08              | 5.66            | 25.02     | 33.00       |
|               |                 |      | E1       | V            | 122.73             | 17.40             | 10.08              | 5.66            | 21.82     | 33.00       |
|               |                 |      |          | H            | 122.92             | 18.81             | 10.08              | 5.66            | 23.23     | 33.00       |
|               |                 |      | E2       | V            | 122.00             | 17.67             | 10.08              | 5.66            | 22.09     | 33.00       |
|               |                 |      |          | H            | 125.14             | 21.03             | 10.08              | 5.66            | 25.45     | 33.00       |

**Remark :**

- (1) The RBW,VBW of SPA for frequency  
 Below 1GHz was RBW=100 KHz, VBW=300KHz,  
 Above 1GHz was RBW= 1MHz , VBW= 3MHz

## 9 MODULATION CHARACTERISTIC

According to FCC Part 2.1047(d), Part 22H & 24E there is no specific requirement for digital modulation, therefore modulation characteristic is not presented.



## 10 OCCUPIED BANDWIDTH

### 10.1 Standard Applicable

CFR 47 Part 2.1049

### 10.2 Test setup

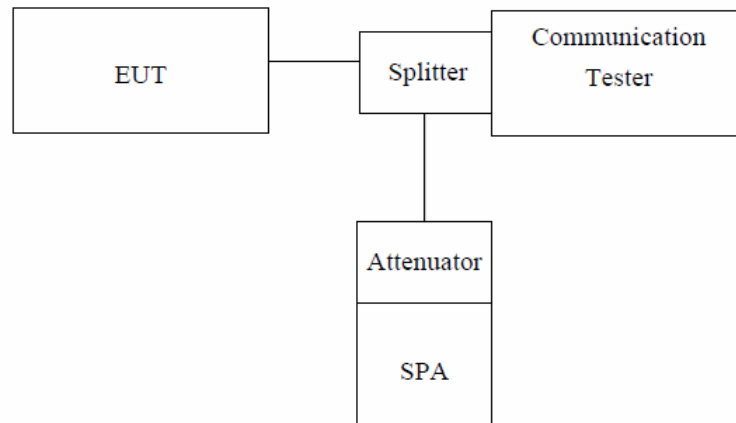

*Note: Measurement setup for testing on Antenna connector*

### 10.3 Test Procedure

The EUT's output RF connector was connected with a short cable to the spectrum analyzer, RBW (10/50KHz) was set to about 1% of emission BW, VBW= 3 times RBW(30/150KHz), -26dBc display line was placed on the screen (or 99% bandwidth), the occupied bandwidth is the delta frequency between the two points where the display line intersects the signal trace.

### 10.4 Test Result

| EUT Mode        | Frequency(MHz) | CH   | 26dB bandwidth(MHz) | 99% Bandwidth(MHz) |
|-----------------|----------------|------|---------------------|--------------------|
| WCDMA<br>Band V | 824.40         | 4132 | 4.650               | 4.157              |
|                 | 836.00         | 4180 | 4.661               | 4.186              |
|                 | 846.60         | 4233 | 4.636               | 4.153              |

| EUT Mode         | Frequency(MHz) | CH   | 26dB bandwidth(MHz) | 99% Bandwidth(MHz) |
|------------------|----------------|------|---------------------|--------------------|
| WCDMA<br>Band II | 1852.40        | 9262 | 4.637               | 4.167              |
|                  | 1880.00        | 9400 | 4.647               | 4.172              |
|                  | 1907.60        | 9538 | 4.631               | 4.169              |

Please refer to the following plots.

|            |              |               |      |
|------------|--------------|---------------|------|
| Test mode: | WCDMA Band V | Test channel: | 4132 |
|------------|--------------|---------------|------|

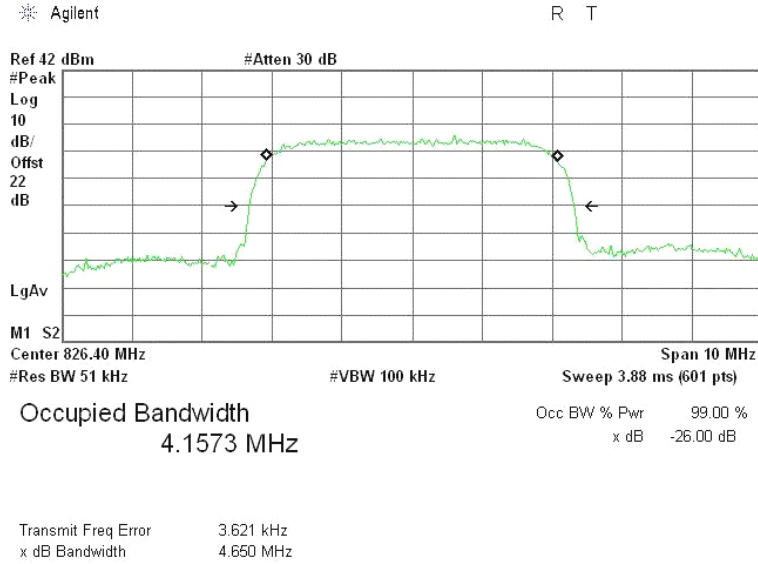

|            |              |               |      |
|------------|--------------|---------------|------|
| Test mode: | WCDMA Band V | Test channel: | 4180 |
|------------|--------------|---------------|------|

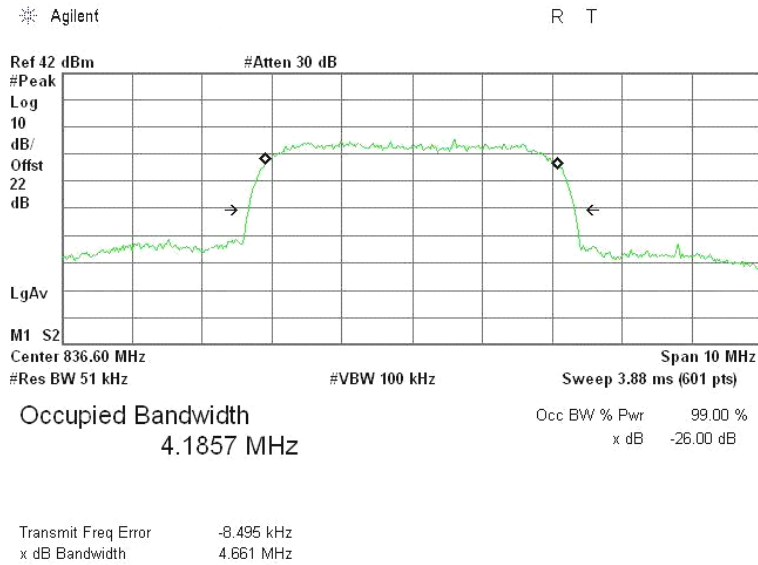

|            |              |               |      |
|------------|--------------|---------------|------|
| Test mode: | WCDMA Band V | Test channel: | 4233 |
|------------|--------------|---------------|------|

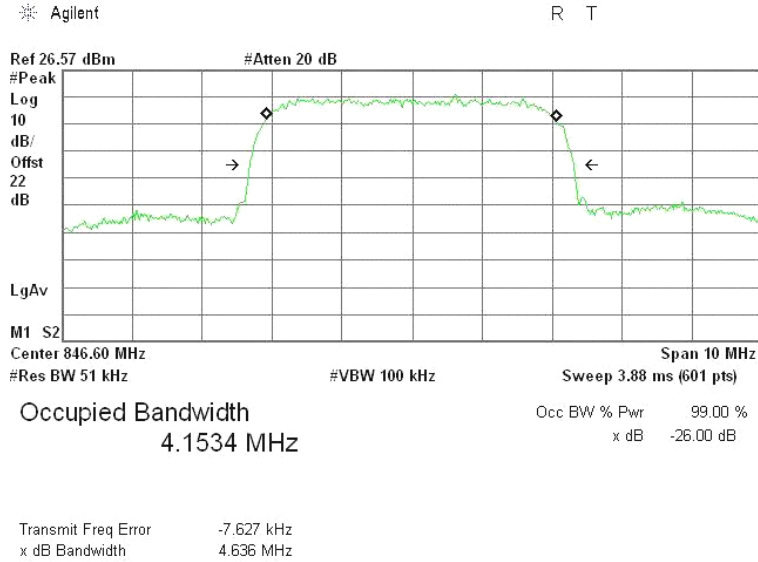

|            |               |               |      |
|------------|---------------|---------------|------|
| Test mode: | WCDMA Band II | Test channel: | 9262 |
|------------|---------------|---------------|------|

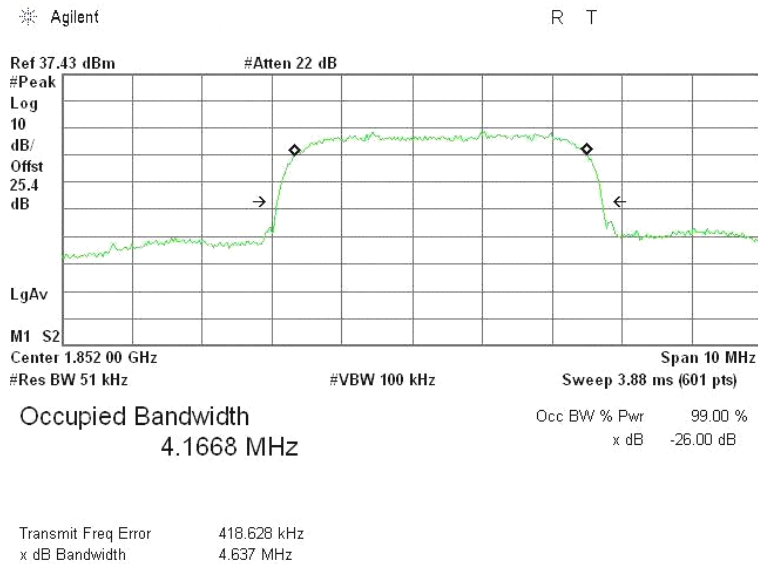

|            |               |               |      |
|------------|---------------|---------------|------|
| Test mode: | WCDMA Band II | Test channel: | 9400 |
|------------|---------------|---------------|------|

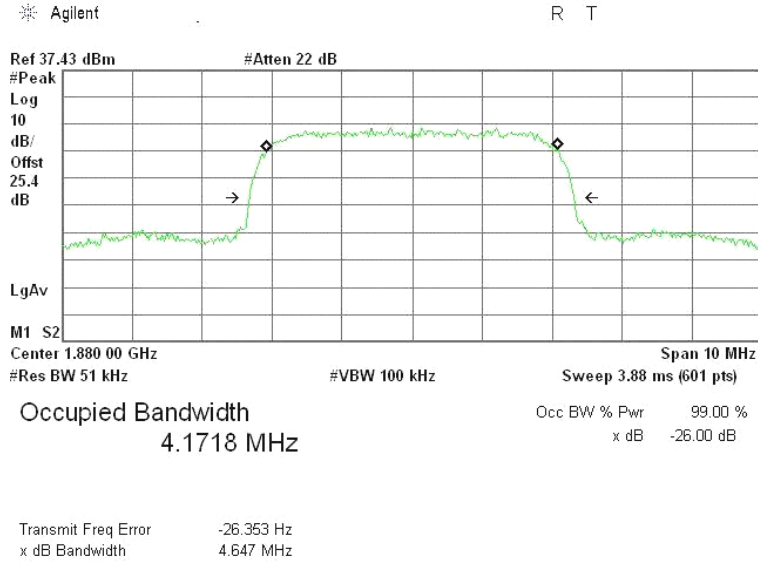

|            |               |               |      |
|------------|---------------|---------------|------|
| Test mode: | WCDMA Band II | Test channel: | 9538 |
|------------|---------------|---------------|------|

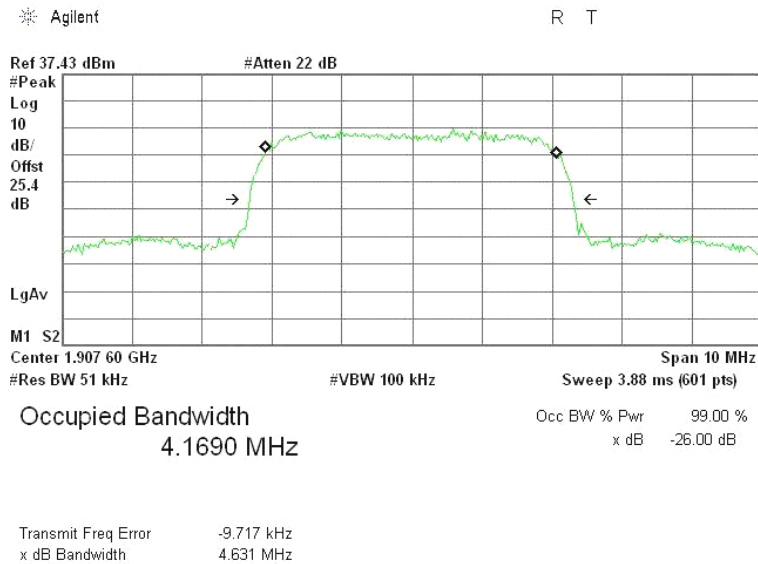

## 11 OUT OF BAND EMISSION AT ANTENNA TERMINALS

### 11.1 Standard Applicable

According to FCC Part 2.1051.

FCC Part 22.917(a), Part 24.238(a), the magnitude of each spurious and harmonic emission that can be detected when the equipment is operated under the conditions specified in the instruction manual and/ or alignment procedure, shall not be less than  $43 + 10 \log$  (mean output power in watts) dBc below the mean power output outside a license's frequency block (-13dBm)

### 11.2 Test setup

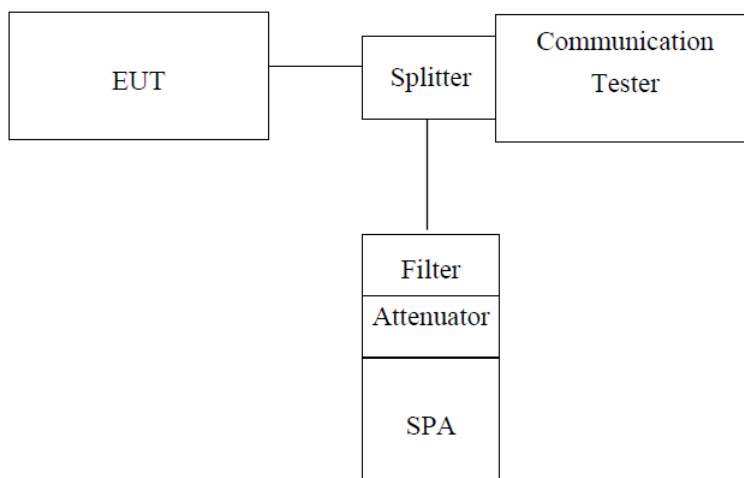

*Note: Measurement setup for testing on Antenna connector*

### 11.3 Measurement Procedure

The RF output of the transceiver was connected to a spectrum analyzer through appropriate attenuation. The resolution bandwidth of the spectrum analyzer was set at 1MHz, sufficient scans were taken to show the out of band Emissions if any up to 10th harmonic.

For the out of band: Set the RBW, VBW = 1MHz, Start=30MHz, Stop= 10th harmonic.

Limit = -13dBm

Band Edge Requirements: In the 1 MHz bands immediately outside and adjacent to the frequency block, a resolution bandwidth of at least 1 percent of the emission bandwidth of the fundamental emission of the transmitter may be employed to measure the out of band Emissions.

Limit = -13dBm.

## 11.4 Measurement Result

### 11.4.1 Spurious emission

|            |              |               |      |
|------------|--------------|---------------|------|
| Test mode: | WCDMA Band V | Test channel: | 4132 |
|------------|--------------|---------------|------|

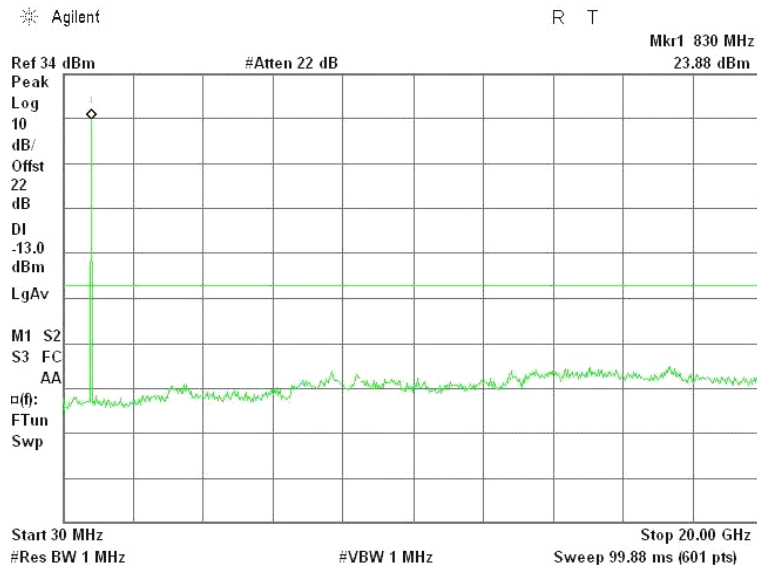

|            |              |               |      |
|------------|--------------|---------------|------|
| Test mode: | WCDMA Band V | Test channel: | 4180 |
|------------|--------------|---------------|------|

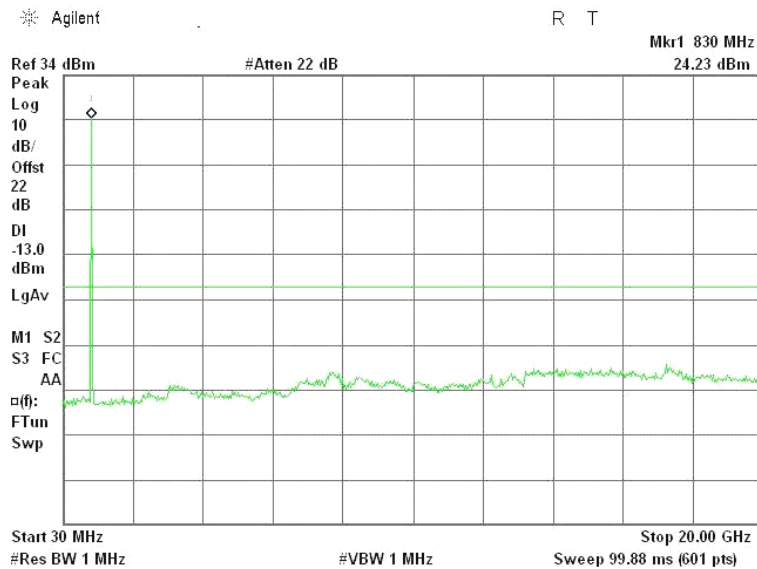

|            |              |               |      |
|------------|--------------|---------------|------|
| Test mode: | WCDMA Band V | Test channel: | 4233 |
|------------|--------------|---------------|------|

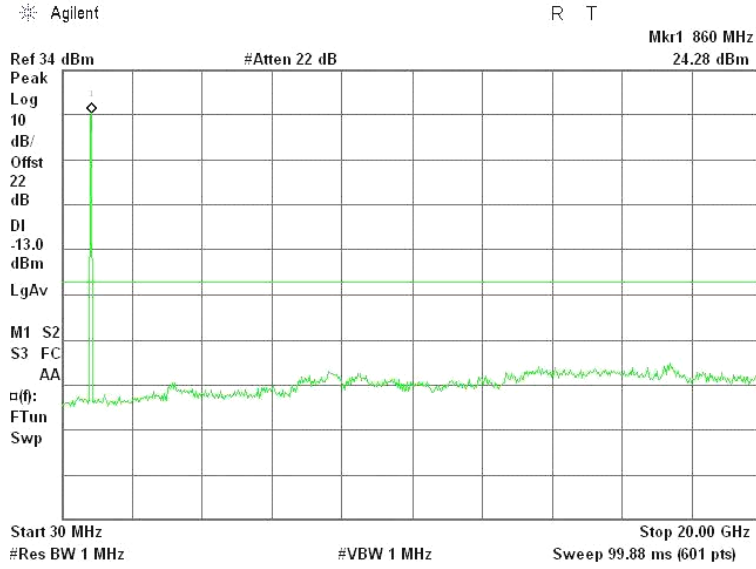

|            |               |               |      |
|------------|---------------|---------------|------|
| Test mode: | WCDMA Band II | Test channel: | 9262 |
|------------|---------------|---------------|------|

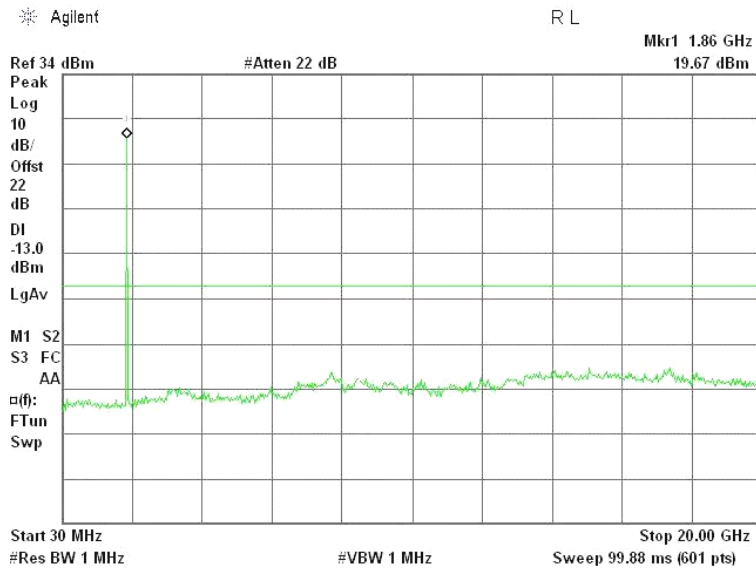

|            |               |               |      |
|------------|---------------|---------------|------|
| Test mode: | WCDMA Band II | Test channel: | 9400 |
|------------|---------------|---------------|------|

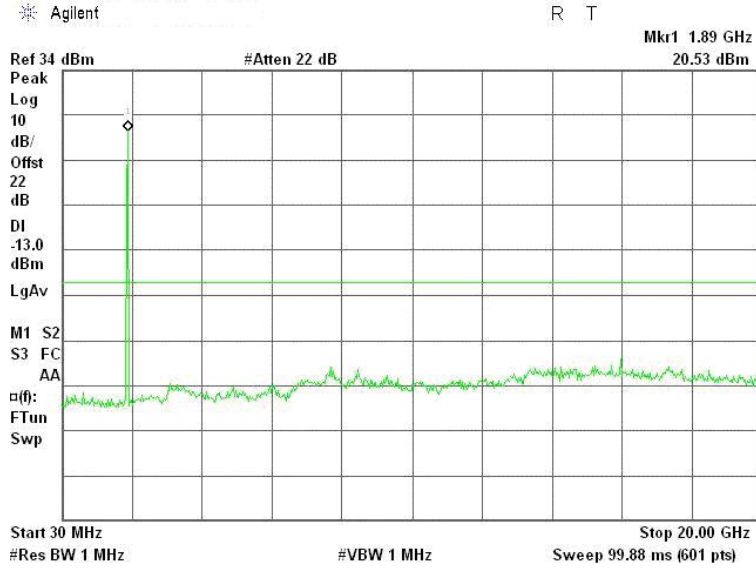

|            |               |               |      |
|------------|---------------|---------------|------|
| Test mode: | WCDMA Band II | Test channel: | 9538 |
|------------|---------------|---------------|------|

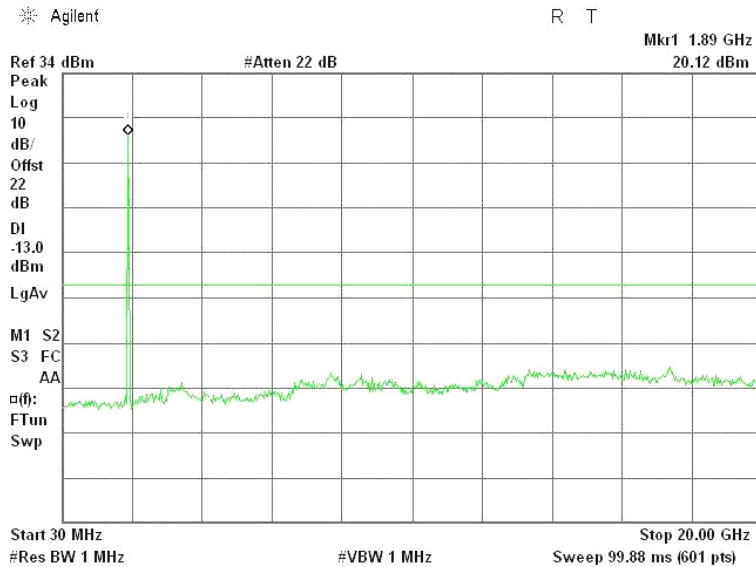



## 11.4.2 Band edge emission

|            |              |               |      |
|------------|--------------|---------------|------|
| Test mode: | WCDMA Band V | Test channel: | 4132 |
|------------|--------------|---------------|------|

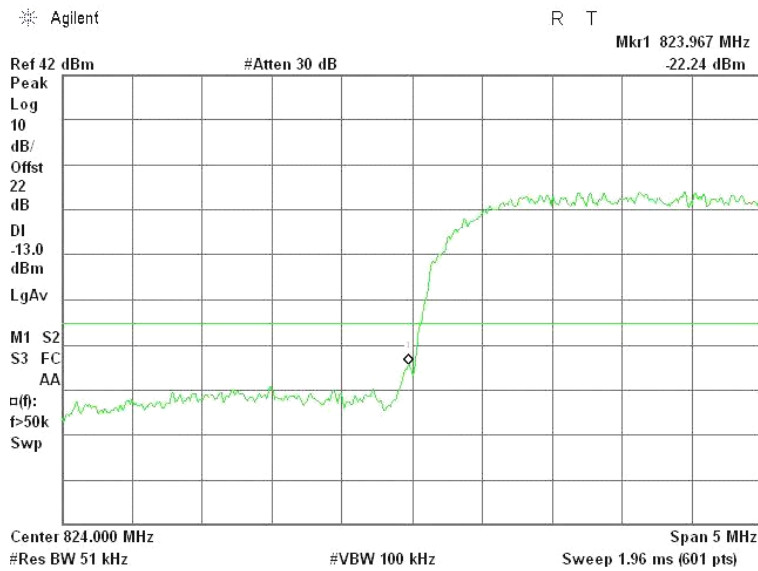

|            |              |               |      |
|------------|--------------|---------------|------|
| Test mode: | WCDMA Band V | Test channel: | 4233 |
|------------|--------------|---------------|------|

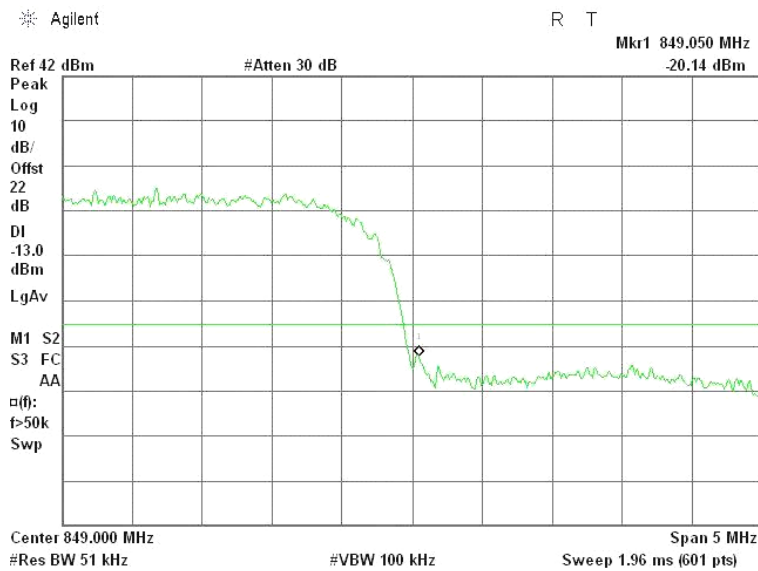

|            |               |               |      |
|------------|---------------|---------------|------|
| Test mode: | WCDMA Band II | Test channel: | 9262 |
|------------|---------------|---------------|------|

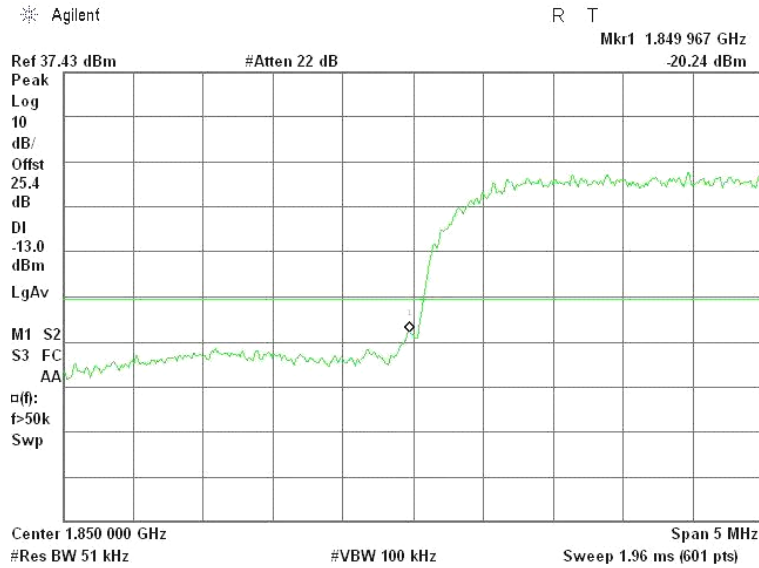

|            |               |               |      |
|------------|---------------|---------------|------|
| Test mode: | WCDMA Band II | Test channel: | 9538 |
|------------|---------------|---------------|------|

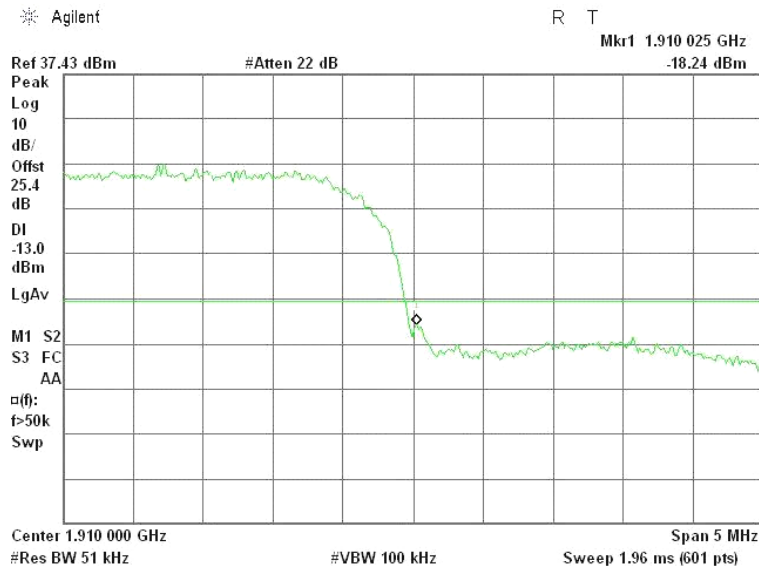

## 12 FIELD STRENGTH OF SPURIOUS RADIATION MEASUREMENT

### 12.1 Standard Applicable

According to FCC Part 2.1053,

FCC Part 22.917(a), Part 24.238(a), the magnitude of each spurious and harmonic emission that can be detected when the equipment is operated under the conditions specified in the instruction manual and/ or alignment procedure, shall not be less than  $43 + 10 \log$  (mean output power in watts) dBc below the mean power output outside a license's frequency block (-13dBm)

### 12.2 EUT Setup (Block Diagram of Configuration)

(A) Radiated Emission Test Set-Up, Frequency below 1000MHz

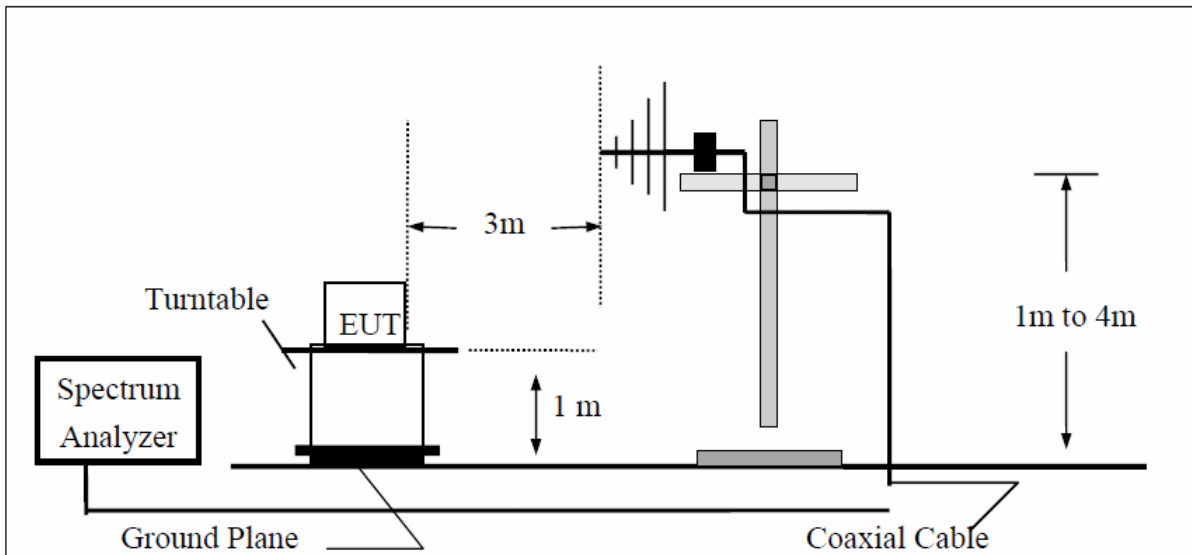

(B) Radiated Emission Test Set-UP Frequency over 1 GHz

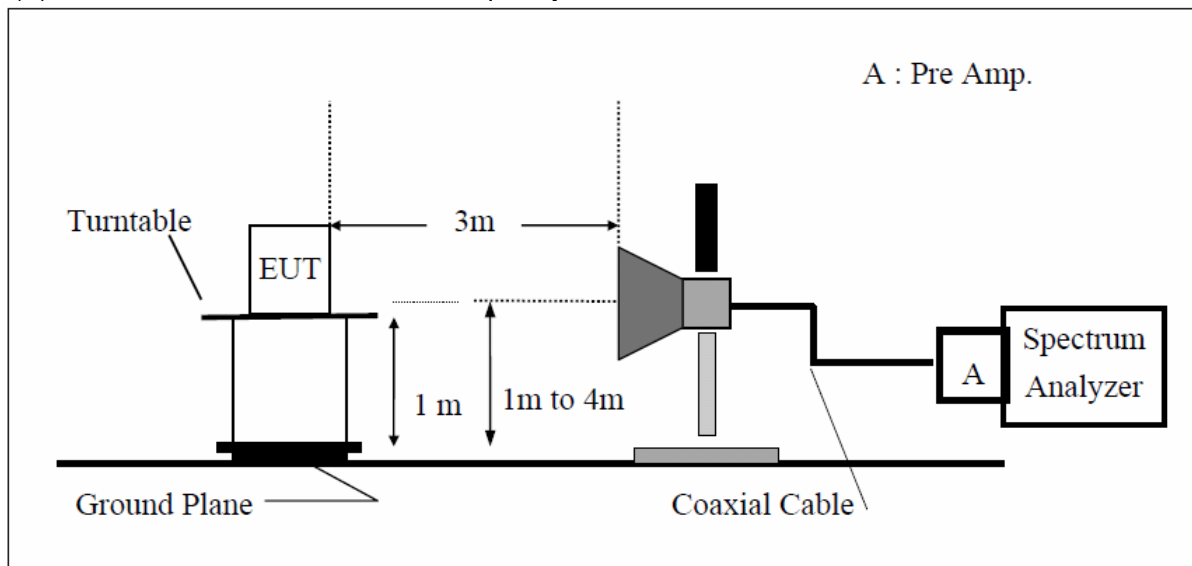

(C) Substituted Method Test Set-UP

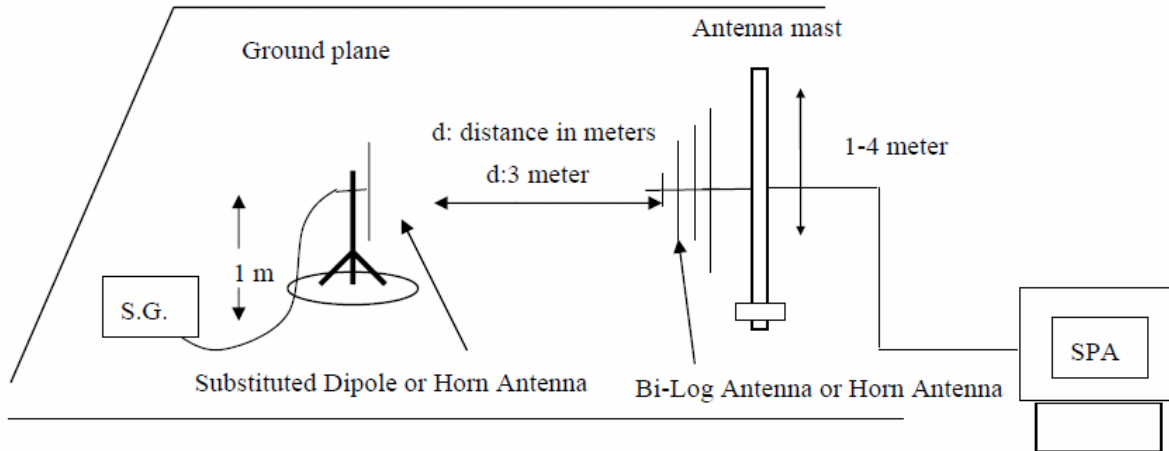

## 12.3 Measurement Procedure

The EUT was placed on a non-conductive, The measurement antenna was placed at a distance of 3 meters from the EUT. During the tests, the antenna height and the EUT azimuth were varied in order to identify the maximum level of emissions from the EUT. This maximization process was repeated with the EUT positioned in each of its three orthogonal orientations.

The frequency range up to tenth harmonic was investigated for each of three fundamental frequency (low, middle and high channels). Once spurious emission were identified, the power of the emission was determined using the substitution method.

The spurious emissions attenuation was calculated as the difference between radiated power at the fundamental frequency and the spurious emissions frequency.

$$\text{EIRP} = \text{S.G. output (dBm)} + \text{Antenna Gain(dBi)} - \text{Cable Loss (dB)}$$

## 12.4 Test Result

|            |              |               |      |              |   |
|------------|--------------|---------------|------|--------------|---|
| Test mode: | WCDMA Band V | Test channel: | 4132 | EUT position | H |
|------------|--------------|---------------|------|--------------|---|

| Frequency (MHz) | SPA reading | Ant. Pol. | S.G output (dBm) | Antenna Gain (dB/dBi) | Cable Loss (dB) | ERP/EIRP (dBm) | Limit (dBm) | Margin (dBm) |
|-----------------|-------------|-----------|------------------|-----------------------|-----------------|----------------|-------------|--------------|
| 345.58          | 54.67       | V         | -50.03           | -7.34                 | 0.95            | -58.32         | -13.00      | -45.32       |
| 761.84          | 50.71       | V         | -51.05           | -7.76                 | 1.37            | -60.18         | -13.00      | -47.18       |
| 824.00          | 78.69       | V         | -7.31            | -7.87                 | 3.62            | -18.80         | -13.00      | -5.80        |
| 1652.80         | 67.31       | V         | -37.27           | 9.29                  | 5.23            | -33.21         | -13.00      | -20.21       |
| 2479.20         | 63.76       | V         | -35.25           | 10.08                 | 6.53            | -31.70         | -13.00      | -18.70       |
| 3305.60         | ---         | V         |                  |                       |                 |                | -13.00      |              |
| 4132.00         | ---         | V         |                  |                       |                 |                | -13.00      |              |
| 4958.40         | ---         | V         |                  |                       |                 |                | -13.00      |              |
| 5784.80         | ---         | V         |                  |                       |                 |                | -13.00      |              |

| Frequency (MHz) | SPA reading | Ant. Pol. | S.G output (dBm) | Antenna Gain (dB/dBi) | Cable Loss (dB) | ERP/EIRP (dBm) | Limit (dBm) | Margin (dBm) |
|-----------------|-------------|-----------|------------------|-----------------------|-----------------|----------------|-------------|--------------|
| 345.58          | 53.29       | H         | -53.50           | -7.34                 | 0.95            | -61.79         | -13.00      | -48.79       |
| 761.84          | 52.91       | H         | -49.51           | -7.76                 | 1.37            | -58.64         | -13.00      | -45.64       |
| 824.00          | 76.66       | H         | -9.73            | -7.87                 | 3.62            | -21.22         | -13.00      | -8.22        |
| 1652.80         | 68.03       | H         | -37.79           | 9.29                  | 5.23            | -33.73         | -13.00      | -20.73       |
| 2479.20         | 67.08       | H         | -37.99           | 10.08                 | 6.53            | -34.44         | -13.00      | -21.44       |
| 3305.60         | ---         | H         |                  |                       |                 |                | -13.00      |              |
| 4132.00         | ---         | H         |                  |                       |                 |                | -13.00      |              |
| 4958.40         | ---         | H         |                  |                       |                 |                | -13.00      |              |
| 5784.80         | ---         | H         |                  |                       |                 |                | -13.00      |              |

Remark :

- 1 The emission behaviour belongs to narrowband spurious emission.
- 2 Remark"---" means that the emission level is too low to be measured
- 3 The result basic equation calculation is as follows:

$$\text{ERP/EIRP (dBm)} = \text{SG Setting(dBm)} + \text{Antenna Gain (dB/dBi)} - \text{Cable loss (dB)}$$

|            |              |               |      |              |   |
|------------|--------------|---------------|------|--------------|---|
| Test mode: | WCDMA Band V | Test channel: | 4180 | EUT position | H |
|------------|--------------|---------------|------|--------------|---|

| Frequency (MHz) | SPA reading | Ant. Pol. | S.G output (dBm) | Antenna Gain (dB/dBi) | Cable Loss (dB) | ERP/EIRP (dBm) | Limit (dBm) | Margin (dBm) |
|-----------------|-------------|-----------|------------------|-----------------------|-----------------|----------------|-------------|--------------|
| 295.68          | 50.86       | V         | -45.98           | -7.67                 | 1.10            | -54.75         | -13.00      | -41.75       |
| 651.27          | 47.78       | V         | -44.48           | -7.83                 | 1.58            | -53.89         | -13.00      | -40.89       |
| 1672.00         | 67.44       | V         | -30.99           | 9.36                  | 5.27            | -26.90         | -13.00      | -13.90       |
| 2508.00         | 66.78       | V         | -35.76           | 10.09                 | 6.58            | -32.25         | -13.00      | -19.25       |
| 3344.00         | 69.23       | V         | -36.44           | 12.28                 | 7.79            | -31.95         | -13.00      | -18.95       |
| 4180.00         | ---         | V         |                  |                       |                 |                | -13.00      |              |
| 5016.00         | ---         | V         |                  |                       |                 |                | -13.00      |              |
| 5852.00         | ---         | V         |                  |                       |                 |                | -13.00      |              |
| 6688.00         | ---         | V         |                  |                       |                 |                | -13.00      |              |

| Frequency (MHz) | SPA reading | Ant. Pol. | S.G output (dBm) | Antenna Gain (dB/dBi) | Cable Loss (dB) | ERP/EIRP (dBm) | Limit (dBm) | Margin (dBm) |
|-----------------|-------------|-----------|------------------|-----------------------|-----------------|----------------|-------------|--------------|
| 295.68          | 52.10       | H         | -46.17           | -7.67                 | 1.10            | -54.94         | -13.00      | -41.94       |
| 651.27          | 52.01       | H         | -43.40           | -7.83                 | 1.58            | -52.81         | -13.00      | -39.81       |
| 1672.00         | 69.29       | H         | -29.51           | 9.36                  | 5.27            | -25.42         | -13.00      | -12.42       |
| 2508.00         | 67.24       | H         | -36.51           | 10.09                 | 6.58            | -33.00         | -13.00      | -20.00       |
| 3344.00         | 66.82       | H         | -37.25           | 12.28                 | 7.79            | -32.76         | -13.00      | -19.76       |
| 4180.00         | ---         | H         |                  |                       |                 |                | -13.00      |              |
| 5016.00         | ---         | H         |                  |                       |                 |                | -13.00      |              |
| 5852.00         | ---         | H         |                  |                       |                 |                | -13.00      |              |
| 6688.00         | ---         | H         |                  |                       |                 |                | -13.00      |              |

Remark :

- 1 The emission behaviour belongs to narrowband spurious emission.
- 2 Remark"---" means that the emission level is too low to be measured
- 3 The result basic equation calculation is as follows:

$$\text{ERP/EIRP (dBm)} = \text{SG Setting(dBm)} + \text{Antenna Gain (dB/dBi)} - \text{Cable loss (dB)}$$

|            |              |               |      |              |   |
|------------|--------------|---------------|------|--------------|---|
| Test mode: | WCDMA Band V | Test channel: | 4233 | EUT position | H |
|------------|--------------|---------------|------|--------------|---|

| Frequency (MHz) | SPA reading | Ant. Pol. | S.G output (dBm) | Antenna Gain (dB/dBi) | Cable Loss (dB) | ERP/EIRP (dBm) | Limit (dBm) | Margin (dBm) |
|-----------------|-------------|-----------|------------------|-----------------------|-----------------|----------------|-------------|--------------|
| 325.48          | 51.58       | V         | -49.09           | -7.77                 | 1.38            | -58.24         | -13.00      | -45.24       |
| 748.51          | 49.75       | V         | -47.33           | -7.88                 | 2.88            | -58.09         | -13.00      | -45.09       |
| 849.00          | 74.34       | V         | -8.20            | -7.88                 | 3.68            | -19.76         | -13.00      | -6.76        |
| 1693.20         | 67.38       | V         | -36.47           | 9.44                  | 5.31            | -32.34         | -13.00      | -19.34       |
| 2539.80         | 68.52       | V         | -30.56           | 10.20                 | 6.63            | -26.99         | -13.00      | -13.99       |
| 3386.40         | ---         | V         |                  |                       |                 |                | -13.00      |              |
| 4233.00         | ---         | V         |                  |                       |                 |                | -13.00      |              |
| 5079.60         | ---         | V         |                  |                       |                 |                | -13.00      |              |
| 5926.20         | ---         | V         |                  |                       |                 |                | -13.00      |              |

| Frequency (MHz) | SPA reading | Ant. Pol. | S.G output (dBm) | Antenna Gain (dB/dBi) | Cable Loss (dB) | ERP/EIRP (dBm) | Limit (dBm) | Margin (dBm) |
|-----------------|-------------|-----------|------------------|-----------------------|-----------------|----------------|-------------|--------------|
| 212.57          | 52.43       | H         | -44.94           | -7.77                 | 1.38            | -54.09         | -13.00      | -41.09       |
| 598.68          | 52.46       | H         | -41.94           | -7.88                 | 2.88            | -52.70         | -13.00      | -39.70       |
| 849.00          | 72.67       | H         | -9.80            | -7.88                 | 3.68            | -21.36         | -13.00      | -8.36        |
| 1693.20         | 68.94       | H         | -35.78           | 9.44                  | 5.31            | -31.65         | -13.00      | -18.65       |
| 2539.80         | 69.63       | H         | -31.73           | 10.20                 | 6.63            | -28.16         | -13.00      | -15.16       |
| 3386.40         | ---         | H         |                  |                       |                 |                | -13.00      |              |
| 4233.00         | ---         | H         |                  |                       |                 |                | -13.00      |              |
| 5079.60         | ---         | H         |                  |                       |                 |                | -13.00      |              |
| 5926.20         | ---         | H         |                  |                       |                 |                | -13.00      |              |

Remark :

- 1 The emission behaviour belongs to narrowband spurious emission.
- 2 Remark”---“ means that the emission level is too low to be measured
- 3 The result basic equation calculation is as follows:

$$\text{ERP/EIRP (dBm)} = \text{SG Setting(dBm)} + \text{Antenna Gain (dB/dBi)} - \text{Cable loss (dB)}$$

|            |               |               |      |              |   |
|------------|---------------|---------------|------|--------------|---|
| Test mode: | WCDMA Band II | Test channel: | 9262 | EUT position | H |
|------------|---------------|---------------|------|--------------|---|

| Frequency (MHz) | SPA reading | Ant. Pol. | S.G output (dBm) | Antenna Gain (dB/dBi) | Cable Loss (dB) | ERP/EIRP (dBm) | Limit (dBm) | Margin (dBm) |
|-----------------|-------------|-----------|------------------|-----------------------|-----------------|----------------|-------------|--------------|
| 527.54          | 54.67       | V         | -46.85           | -7.83                 | 1.41            | -56.09         | -13.00      | -43.09       |
| 1387.27         | 50.71       | V         | -46.77           | 8.44                  | 4.31            | -42.64         | -13.00      | -29.64       |
| 1850.00         | 75.00       | V         | -23.79           | 9.90                  | 5.56            | -19.45         | -13.00      | -6.45        |
| 3704.80         | 70.07       | V         | -26.96           | 12.61                 | 8.31            | -22.66         | -13.00      | -9.66        |
| 5557.20         | 68.41       | V         | -30.34           | 13.23                 | 10.33           | -27.44         | -13.00      | -14.44       |
| 7409.60         | ---         | V         |                  |                       |                 |                | -13.00      |              |
| 9262.00         | ---         | V         |                  |                       |                 |                | -13.00      |              |
| 11114.40        | ---         | V         |                  |                       |                 |                | -13.00      |              |
| 12966.80        | ---         | V         |                  |                       |                 |                | -13.00      |              |

| Frequency (MHz) | SPA reading | Ant. Pol. | S.G output (dBm) | Antenna Gain (dB/dBi) | Cable Loss (dB) | ERP/EIRP (dBm) | Limit (dBm) | Margin (dBm) |
|-----------------|-------------|-----------|------------------|-----------------------|-----------------|----------------|-------------|--------------|
| 527.54          | 53.96       | H         | -47.95           | -7.83                 | 1.41            | -57.19         | -13.00      | -44.19       |
| 1578.41         | 49.37       | H         | -44.62           | 8.17                  | 4.76            | -41.21         | -13.00      | -28.21       |
| 1850.00         | 73.84       | H         | -25.18           | 9.90                  | 5.56            | -20.84         | -13.00      | -7.84        |
| 3704.80         | 68.06       | H         | -29.11           | 12.61                 | 8.31            | -24.81         | -13.00      | -11.81       |
| 5557.20         | 67.81       | H         | -31.10           | 13.23                 | 10.33           | -28.20         | -13.00      | -15.20       |
| 7409.60         | ---         | H         |                  |                       |                 |                | -13.00      |              |
| 9262.00         | ---         | H         |                  |                       |                 |                | -13.00      |              |
| 11114.40        | ---         | H         |                  |                       |                 |                | -13.00      |              |
| 12966.80        | ---         | H         |                  |                       |                 |                | -13.00      |              |

Remark :

- 1 The emission behaviour belongs to narrowband spurious emission.
- 2 Remark”---“ means that the emission level is too low to be measured
- 3 The result basic equation calculation is as follows:

$$\text{ERP/EIRP (dBm)} = \text{SG Setting(dBm)} + \text{Antenna Gain (dB/dBi)} - \text{Cable loss (dB)}$$



|            |               |               |      |              |   |
|------------|---------------|---------------|------|--------------|---|
| Test mode: | WCDMA Band II | Test channel: | 9400 | EUT position | H |
|------------|---------------|---------------|------|--------------|---|

| Frequency (MHz) | SPA reading | Ant. Pol. | S.G output (dBm) | Antenna Gain (dB/dBi) | Cable Loss (dB) | ERP/EIRP (dBm) | Limit (dBm) | Margin (dBm) |
|-----------------|-------------|-----------|------------------|-----------------------|-----------------|----------------|-------------|--------------|
| 527.54          | 55.55       | V         | -45.90           | -7.83                 | 1.41            | -55.14         | -13.00      | -42.14       |
| 1607.43         | 49.98       | V         | -43.91           | 8.19                  | 4.82            | -40.54         | -13.00      | -27.54       |
| 3760.00         | 71.87       | V         | -26.64           | 12.60                 | 8.39            | -22.43         | -13.00      | -9.43        |
| 5640.00         | 65.99       | V         | -33.33           | 13.36                 | 10.41           | -30.38         | -13.00      | -17.38       |
| 7520.00         | 66.54       | V         | -32.38           | 11.45                 | 12.19           | -33.12         | -13.00      | -20.12       |
| 9400.00         | ---         | V         |                  |                       |                 |                | -13.00      |              |
| 11280.00        | ---         | V         |                  |                       |                 |                | -13.00      |              |
| 13160.00        | ---         | V         |                  |                       |                 |                | -13.00      |              |
| 15040.00        | ---         | V         |                  |                       |                 |                | -13.00      |              |

| Frequency (MHz) | SPA reading | Ant. Pol. | S.G output (dBm) | Antenna Gain (dB/dBi) | Cable Loss (dB) | ERP/EIRP (dBm) | Limit (dBm) | Margin (dBm) |
|-----------------|-------------|-----------|------------------|-----------------------|-----------------|----------------|-------------|--------------|
| 527.54          | 56.83       | H         | -45.05           | -7.83                 | 1.41            | -54.29         | -13.00      | -41.29       |
| 1201.45         | 50.23       | H         | -45.43           | 7.89                  | 4.58            | -42.12         | -13.00      | -29.12       |
| 3760.00         | 72.73       | H         | -26.36           | 12.60                 | 8.39            | -22.15         | -13.00      | -9.15        |
| 5640.00         | 66.53       | H         | -32.03           | 13.36                 | 10.41           | -29.08         | -13.00      | -16.08       |
| 7520.00         | 68.43       | H         | -30.80           | 11.45                 | 12.19           | -31.54         | -13.00      | -18.54       |
| 9400.00         | ---         | H         |                  |                       |                 |                | -13.00      |              |
| 11280.00        | ---         | H         |                  |                       |                 |                | -13.00      |              |
| 13160.00        | ---         | H         |                  |                       |                 |                | -13.00      |              |
| 15040.00        | ---         | H         |                  |                       |                 |                | -13.00      |              |

Remark :

- 1 The emission behaviour belongs to narrowband spurious emission.
- 2 Remark"---" means that the emission level is too low to be measured
- 3 The result basic equation calculation is as follows:

$$\text{ERP/EIRP (dBm)} = \text{SG Setting(dBm)} + \text{Antenna Gain (dB/dBi)} - \text{Cable loss (dB)}$$

|            |               |               |      |              |   |
|------------|---------------|---------------|------|--------------|---|
| Test mode: | WCDMA Band II | Test channel: | 9538 | EUT position | H |
|------------|---------------|---------------|------|--------------|---|

| Frequency (MHz) | SPA reading | Ant. Pol. | S.G output (dBm) | Antenna Gain (dB/dBi) | Cable Loss (dB) | ERP/EIRP (dBm) | Limit (dBm) | Margin (dBm) |
|-----------------|-------------|-----------|------------------|-----------------------|-----------------|----------------|-------------|--------------|
| 527.54          | 55.55       | V         | -45.97           | -7.83                 | 1.41            | -55.21         | -13.00      | -42.21       |
| 1388.22         | 50.98       | V         | -44.11           | 7.56                  | 4.56            | -41.11         | -13.00      | -28.11       |
| 1910.00         | 74.35       | V         | -22.88           | 10.08                 | 5.66            | -18.46         | -13.00      | -5.46        |
| 3815.20         | 63.89       | V         | -32.56           | 12.60                 | 8.69            | -28.65         | -13.00      | -15.65       |
| 5722.80         | 65.32       | V         | -32.12           | 13.86                 | 10.73           | -28.99         | -13.00      | -15.99       |
| 7630.40         | ---         | V         |                  |                       |                 |                | -13.00      |              |
| 9538.00         | ---         | V         |                  |                       |                 |                | -13.00      |              |
| 11445.60        | ---         | V         |                  |                       |                 |                | -13.00      |              |
| 13353.20        | ---         | V         |                  |                       |                 |                | -13.00      |              |

| Frequency (MHz) | SPA reading | Ant. Pol. | S.G output (dBm) | Antenna Gain (dB/dBi) | Cable Loss (dB) | ERP/EIRP (dBm) | Limit (dBm) | Margin (dBm) |
|-----------------|-------------|-----------|------------------|-----------------------|-----------------|----------------|-------------|--------------|
| 527.54          | 54.84       | H         | -46.81           | -7.83                 | 1.41            | -56.05         | -13.00      | -43.05       |
| 895.39          | 52.18       | H         | -43.85           | -7.84                 | 3.68            | -55.37         | -13.00      | -42.37       |
| 1910.00         | 72.59       | H         | -24.56           | 10.08                 | 5.66            | -20.14         | -13.00      | -7.14        |
| 3815.20         | 62.09       | H         | -34.93           | 12.60                 | 8.69            | -31.02         | -13.00      | -18.02       |
| 5722.80         | 64.45       | H         | -35.31           | 13.86                 | 10.73           | -32.18         | -13.00      | -19.18       |
| 7630.40         | ---         | H         |                  |                       |                 |                | -13.00      |              |
| 9538.00         | ---         | H         |                  |                       |                 |                | -13.00      |              |
| 11445.60        | ---         | H         |                  |                       |                 |                | -13.00      |              |
| 13353.20        | ---         | H         |                  |                       |                 |                | -13.00      |              |

Remark :

- 1 The emission behaviour belongs to narrowband spurious emission.
- 2 Remark"---" means that the emission level is too low to be measured
- 3 The result basic equation calculation is as follows:

$$\text{ERP/EIRP (dBm)} = \text{SG Setting(dBm)} + \text{Antenna Gain (dB/dBi)} - \text{Cable loss (dB)}$$

## 13 FREQUENCY STABILITY V.S. TEMPERATURE MEASUREMENT

### 13.1 Standard Applicable

According to FCC Part 2.1055(a)(1)(b).

Frequency Tolerance: 2.5 ppm

### 13.2 Test setup

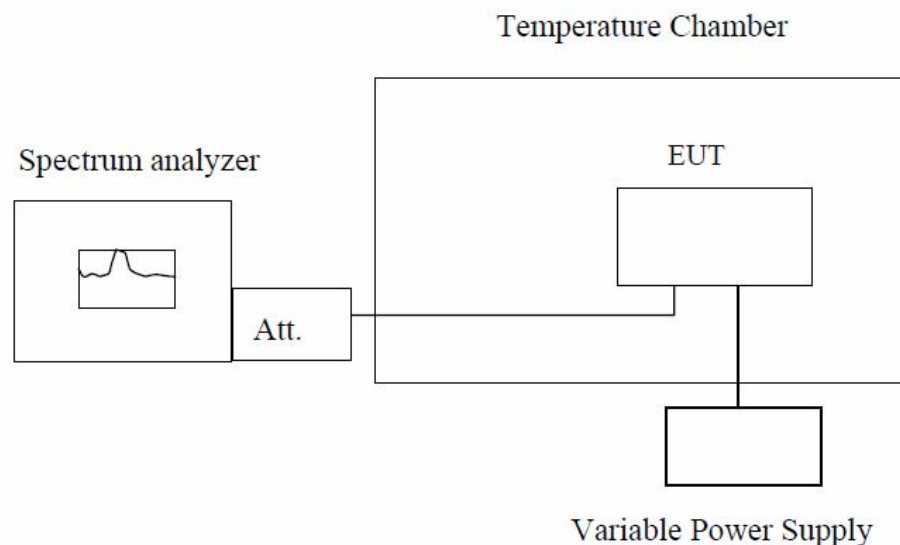

**Note :** Measurement setup for testing on Antenna connector

### 13.3 Test Procedure

The equipment under test was connected to an external AC or DC power supply and input rated voltage. RF output was connected to a frequency counter or spectrum analyzer via feed through attenuators. The EUT was placed inside the temperature chamber. Set the spectrum analyzer RBW low enough to obtain the desired frequency resolution and measure EUT 25°C operating frequency as reference frequency. Turn EUT off and set the chamber temperature to -30°C. After the temperature stabilized for approximately 30 minutes recorded the frequency. Repeat step measure with 10°C increased per stage until the highest temperature of +50°C reached.

## 13.4 Test Result

| Reference Frequency: WCDMA Band V Middle channel 836MHz @25°C |                      |                      |                       |             |
|---|----------------------|----------------------|-----------------------|-------------|
| Temperature (°C)  | Power Supplied (Vdc) | Frequency Error (Hz) | Frequency Error (ppm) | Limit (ppm) |
| -20   | 3.7                  | 45                   | 0.054                 | 2.5         |
| -10   | 3.7                  | 43                   | 0.051                 | 2.5         |
| 0   | 3.7                  | 42                   | 0.050                 | 2.5         |
| 10  | 3.7                  | 38                   | 0.045                 | 2.5         |
| 20  | 3.7                  | 36                   | 0.043                 | 2.5         |
| 30  | 3.7                  | 38                   | 0.045                 | 2.5         |
| 40  | 3.7                  | 37                   | 0.044                 | 2.5         |
| 50  | 3.7                  | 40                   | 0.048                 | 2.5         |

| Reference Frequency: WCDMA Band II Middle channel 1880MHz @25°C |                      |                      |                       |             |
|---|----------------------|----------------------|-----------------------|-------------|
| Temperature (°C)  | Power Supplied (Vdc) | Frequency Error (Hz) | Frequency Error (ppm) | Limit (ppm) |
| -20   | 3.7                  | 52                   | 0.028                 | 2.5         |
| -10   | 3.7                  | 50                   | 0.027                 | 2.5         |
| 0   | 3.7                  | 46                   | 0.024                 | 2.5         |
| 10  | 3.7                  | 48                   | 0.026                 | 2.5         |
| 20  | 3.7                  | 45                   | 0.024                 | 2.5         |
| 30  | 3.7                  | 47                   | 0.025                 | 2.5         |
| 40  | 3.7                  | 49                   | 0.026                 | 2.5         |
| 50  | 3.7                  | 52                   | 0.028                 | 2.5         |

## 14 FREQUENCY STABILITY V.S. VOLTAGE MEASUREMENT

### 14.1 Standard Applicable

According to FCC Part 2.1055(d)(1)(2).

Frequency Tolerance: 2.5 ppm

### 14.2 Test setup

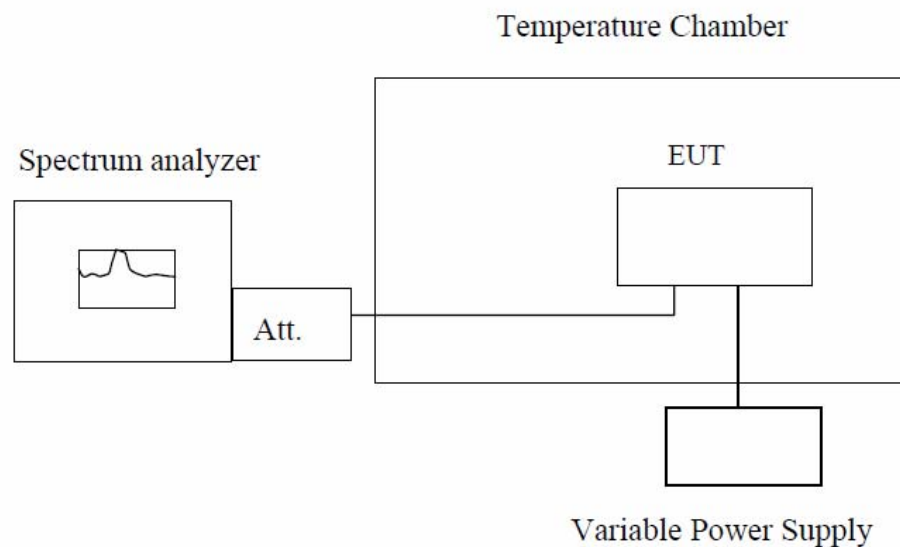

**Note :** Measurement setup for testing on Antenna connector

### 14.3 Test Procedure

Set chamber temperature to 25°C. Use a variable AC power supply / DC power source to power the EUT and set the voltage to rated voltage. Set the spectrum analyzer RBW low enough to obtain the desired frequency resolution and recorded the frequency.

Reduce the input voltage to specified extreme voltage variation (+/- 15%) and endpoint, record the maximum frequency change.

## 14.4 Test Result

| Reference Frequency: WCDMA Band V Middle channel 836MHz @25°C |                      |                      |                       |             |
|---|----------------------|----------------------|-----------------------|-------------|
| Temperature (°C)  | Power Supplied (Vdc) | Frequency Error (Hz) | Frequency Error (ppm) | Limit (ppm) |
| 25  | 4.26                 | 38                   | 0.045                 | 2.5         |
| 25  | 3.70                 | 36                   | 0.043                 | 2.5         |
| 25  | 3.15                 | 34                   | 0.041                 | 2.5         |
| 25  | 2.90                 | 37                   | 0.044                 | 2.5         |

| Reference Frequency: WCDMA Band II Middle channel 1880MHz @25°C |                      |                      |                       |             |
|---|----------------------|----------------------|-----------------------|-------------|
| Temperature (°C)  | Power Supplied (Vdc) | Frequency Error (Hz) | Frequency Error (ppm) | Limit (ppm) |
| 25  | 4.26                 | 46                   | 0.024                 | 2.5         |
| 25  | 3.70                 | 45                   | 0.024                 | 2.5         |
| 25  | 3.15                 | 43                   | 0.023                 | 2.5         |
| 25  | 2.90                 | 46                   | 0.024                 | 2.5         |

Note: The battery is rated 3.7V dc.

## 15 AC POWER LINE CONDUCTED EMISSION TEST

### 15.1 Standard Applicable

According to FCC Part 15.207. The emission value for frequency within 150KHz to 30MHz shall not Exceed criteria of below chart.

| Frequency range (MHz)  | Limits dB(uV) |          |
|--|---------------|----------|
|  | Quasi-peak    | Average  |
| 0.15 to 0.50   | 66 to 56      | 56 to 46 |
| 0.50 to 5  | 56            | 46       |
| 5 to 30  | 60            | 50       |
| Note<br>1.The lower limit shall apply at the transition frequencies<br>2.The limit decreases linearly with the logarithm of the frequency in the range 0.15 MHz to 0.50 MHz. |               |          |

### 15.2 Test setup

1. The conducted emission tests were performed in the test site, using the setup in accordance with the ANSI C63.4-2001.
2. The EUT was plug-in DC power adaptor and was placed on the center of the back edge on the test table. The peripherals like earphone was placed on the side of the EUT. The rear of the EUT and peripherals were placed flushed with the rear of the tabletop.
3. The Power adaptor was connected with 110Vac/60Hz power source.

### 15.3 Test Procedure

1. The EUT was placed on a table which is 0.8m above ground plane.
2. Maximum procedure was performed on the six highest emissions to ensure EUT compliance.
3. Repeat above procedures until all frequency measured were complete.

### 15.4 Measurement Result

Test mode: WCDMA V

Line:

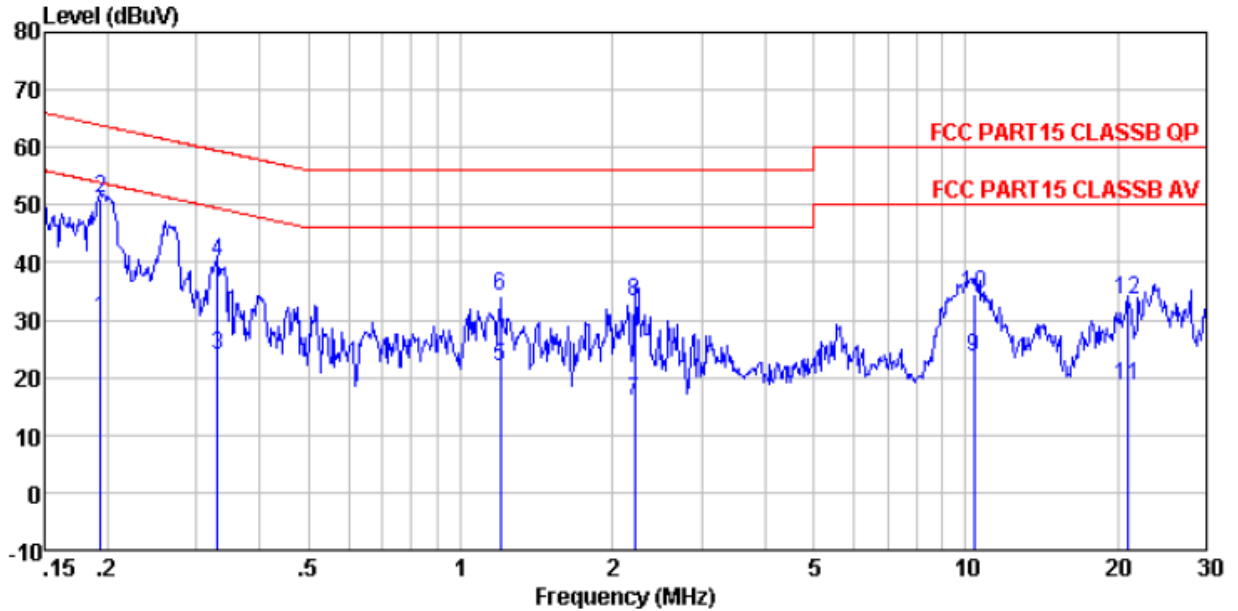

Condition : FCC PART15 CLASSB QP LISN(2011) LINE  
 Job No. : 205IT  
 Test Mode : WCDMA V mode  
 Test Engineer: Duke

|    | Read Freq | Level | LISN Factor | Cable Loss | Level | Limit Line | Over Limit | Remark  |
|----|-----------|-------|-------------|------------|-------|------------|------------|---------|
|    | MHz       | dBuV  | dB          | dB         | dBuV  | dBuV       | dB         |         |
| 1  | 0.193     | 29.46 | 0.66        | 0.10       | 30.22 | 53.89      | -23.67     | Average |
| 2  | 0.193     | 50.33 | 0.66        | 0.10       | 51.09 | 63.89      | -12.80     | QP      |
| 3  | 0.330     | 23.24 | 0.60        | 0.10       | 23.94 | 49.44      | -25.50     | Average |
| 4  | 0.330     | 39.43 | 0.60        | 0.10       | 40.13 | 59.44      | -19.31     | QP      |
| 5  | 1.197     | 21.37 | 0.46        | 0.10       | 21.93 | 46.00      | -24.07     | Average |
| 6  | 1.197     | 33.47 | 0.46        | 0.10       | 34.03 | 56.00      | -21.97     | QP      |
| 7  | 2.213     | 15.38 | 0.39        | 0.10       | 15.87 | 46.00      | -30.13     | Average |
| 8  | 2.213     | 32.64 | 0.39        | 0.10       | 33.13 | 56.00      | -22.87     | QP      |
| 9  | 10.397    | 23.21 | 0.22        | 0.20       | 23.63 | 50.00      | -26.37     | Average |
| 10 | 10.397    | 34.22 | 0.22        | 0.20       | 34.64 | 60.00      | -25.36     | QP      |
| 11 | 20.924    | 18.10 | 0.14        | 0.21       | 18.45 | 50.00      | -31.55     | Average |
| 12 | 20.924    | 33.21 | 0.14        | 0.21       | 33.56 | 60.00      | -26.44     | QP      |



Neutral:

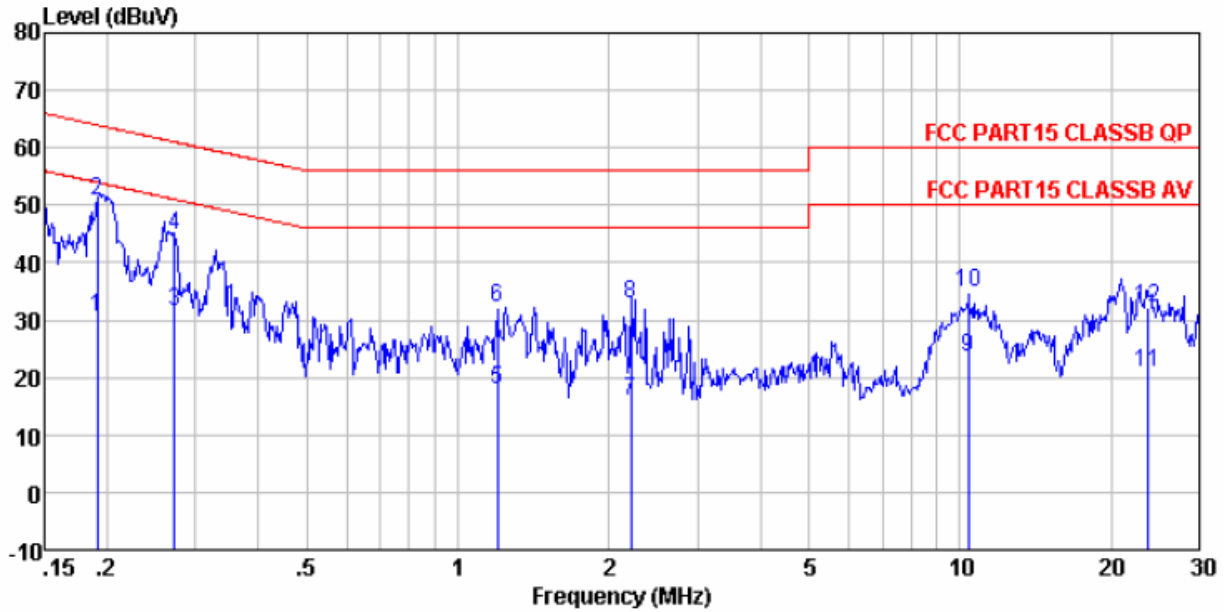

Condition : FCC PART15 CLASSB QP LISN(2011) NEUTRAL  
 Job No. : 205IT  
 Test Mode : WCDMA V mode  
 Test Engineer: Duke

|    | Read Freq | LISN Level | LISN Factor | Cable Loss | Level | Limit Line | Over Limit | Remark  |
|----|-----------|------------|-------------|------------|-------|------------|------------|---------|
|    | MHz       | dBuV       | dB          | dB         | dBuV  | dBuV       | dB         |         |
| 1  | 0.191     | 29.61      | 0.66        | 0.10       | 30.37 | 53.99      | -23.62     | Average |
| 2  | 0.191     | 50.17      | 0.66        | 0.10       | 50.93 | 63.99      | -13.06     | QP      |
| 3  | 0.273     | 30.84      | 0.62        | 0.10       | 31.56 | 51.03      | -19.47     | Average |
| 4  | 0.273     | 44.10      | 0.62        | 0.10       | 44.82 | 61.03      | -16.21     | QP      |
| 5  | 1.197     | 17.28      | 0.46        | 0.10       | 17.84 | 46.00      | -28.16     | Average |
| 6  | 1.197     | 31.74      | 0.46        | 0.10       | 32.30 | 56.00      | -23.70     | QP      |
| 7  | 2.213     | 15.43      | 0.39        | 0.10       | 15.92 | 46.00      | -30.08     | Average |
| 8  | 2.213     | 32.19      | 0.39        | 0.10       | 32.68 | 56.00      | -23.32     | QP      |
| 9  | 10.397    | 23.17      | 0.22        | 0.20       | 23.59 | 50.00      | -26.41     | Average |
| 10 | 10.397    | 34.55      | 0.22        | 0.20       | 34.97 | 60.00      | -25.03     | QP      |
| 11 | 23.636    | 20.60      | 0.13        | 0.21       | 20.94 | 50.00      | -29.06     | Average |
| 12 | 23.636    | 31.91      | 0.13        | 0.21       | 32.25 | 60.00      | -27.75     | QP      |

Test mode: WCDMA II

Line:

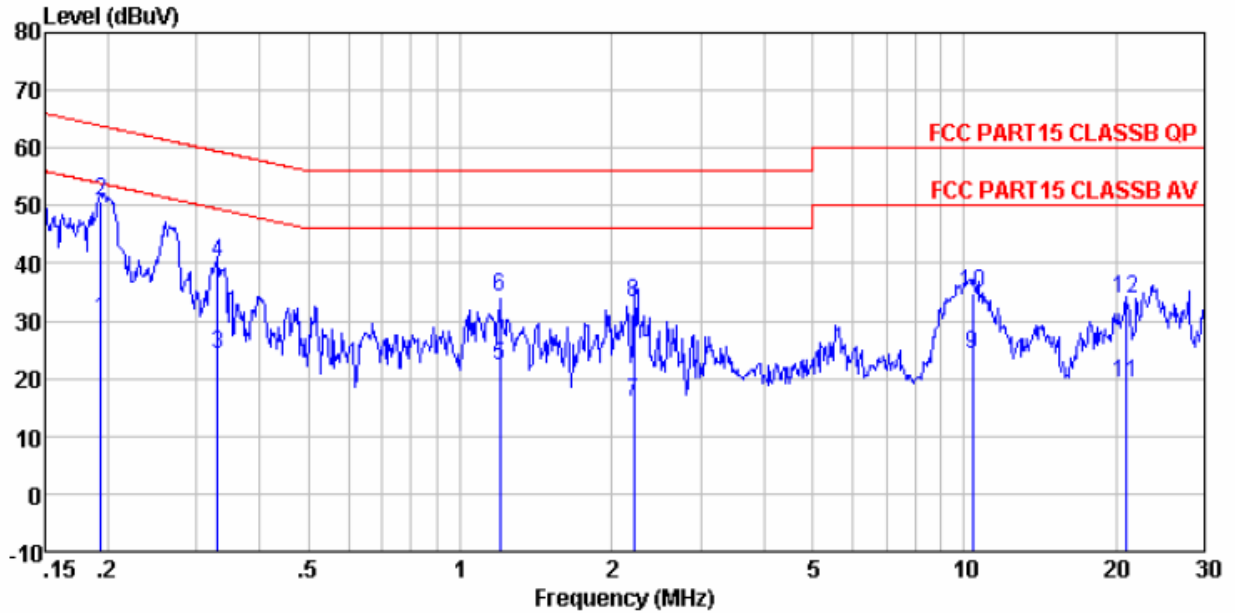

Condition : FCC PART15 CLASSB QP LISN(2011) LINE  
 Job No. : 205IT  
 Test Mode : WCDMA II mode  
 Test Engineer: Duke

|    | Read Freq | LISN Level | Cable Factor | Loss | Level | Limit Line | Over Limit | Remark  |
|----|-----------|------------|--------------|------|-------|------------|------------|---------|
|    | MHz       | dBuV       | dB           | dB   | dBuV  | dBuV       | dB         |         |
| 1  | 0.193     | 29.33      | 0.66         | 0.10 | 30.09 | 53.89      | -23.80     | Average |
| 2  | 0.193     | 50.18      | 0.66         | 0.10 | 50.94 | 63.89      | -12.95     | QP      |
| 3  | 0.330     | 23.66      | 0.60         | 0.10 | 24.36 | 49.44      | -25.08     | Average |
| 4  | 0.330     | 39.31      | 0.60         | 0.10 | 40.01 | 59.44      | -19.43     | QP      |
| 5  | 1.197     | 21.75      | 0.46         | 0.10 | 22.31 | 46.00      | -23.69     | Average |
| 6  | 1.197     | 33.47      | 0.46         | 0.10 | 34.03 | 56.00      | -21.97     | QP      |
| 7  | 2.213     | 15.27      | 0.39         | 0.10 | 15.76 | 46.00      | -30.24     | Average |
| 8  | 2.213     | 32.67      | 0.39         | 0.10 | 33.16 | 56.00      | -22.84     | QP      |
| 9  | 10.397    | 23.65      | 0.22         | 0.20 | 24.07 | 50.00      | -25.93     | Average |
| 10 | 10.397    | 34.26      | 0.22         | 0.20 | 34.68 | 60.00      | -25.32     | QP      |
| 11 | 20.924    | 18.94      | 0.14         | 0.21 | 19.29 | 50.00      | -30.71     | Average |
| 12 | 20.924    | 33.49      | 0.14         | 0.21 | 33.84 | 60.00      | -26.16     | QP      |

Neutral:

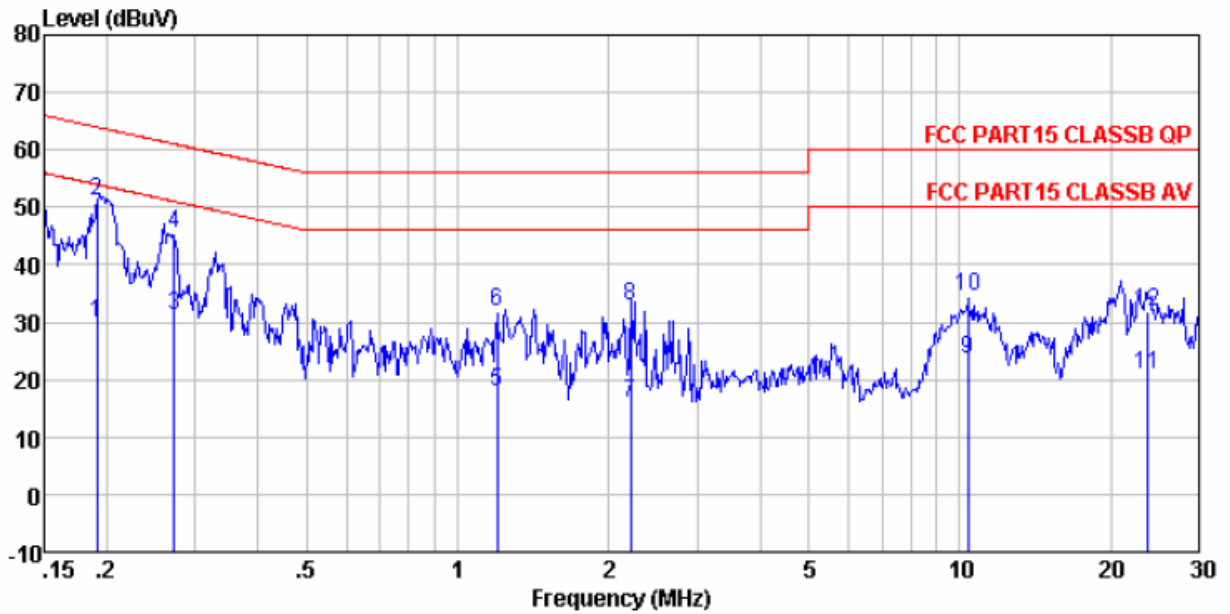

Condition : FCC PART15 CLASSB QP LISN(2011) NEUTRAL  
 Job No. : 205IT  
 Test Mode : MCDMA II mode  
 Test Engineer: Duke

|    | Freq   | Read Level | LISN Factor | Cable Loss | Level | Limit Line | Over Limit | Remark  |
|----|--------|------------|-------------|------------|-------|------------|------------|---------|
|    | MHz    | dBuV       | dB          | dB         | dBuV  | dBuV       | dB         |         |
| 1  | 0.191  | 29.11      | 0.66        | 0.10       | 29.87 | 53.99      | -24.12     | Average |
| 2  | 0.191  | 50.24      | 0.66        | 0.10       | 51.00 | 63.99      | -12.99     | QP      |
| 3  | 0.273  | 30.47      | 0.62        | 0.10       | 31.19 | 51.03      | -19.84     | Average |
| 4  | 0.273  | 44.78      | 0.62        | 0.10       | 45.50 | 61.03      | -15.53     | QP      |
| 5  | 1.197  | 17.47      | 0.46        | 0.10       | 18.03 | 46.00      | -27.97     | Average |
| 6  | 1.197  | 31.45      | 0.46        | 0.10       | 32.01 | 56.00      | -23.99     | QP      |
| 7  | 2.213  | 15.27      | 0.39        | 0.10       | 15.76 | 46.00      | -30.24     | Average |
| 8  | 2.213  | 32.27      | 0.39        | 0.10       | 32.76 | 56.00      | -23.24     | QP      |
| 9  | 10.397 | 23.17      | 0.22        | 0.20       | 23.59 | 50.00      | -26.41     | Average |
| 10 | 10.397 | 34.17      | 0.22        | 0.20       | 34.59 | 60.00      | -25.41     | QP      |
| 11 | 23.636 | 20.47      | 0.13        | 0.21       | 20.81 | 50.00      | -29.19     | Average |
| 12 | 23.636 | 31.47      | 0.13        | 0.21       | 31.81 | 60.00      | -28.19     | QP      |