



The University of Michigan Radiation Laboratory  
3228 EECS Building  
Ann Arbor, Michigan 48109-2122 USA  
Tel: (734) 483-4211  
Fax: (734) 647-2106  
e-mail: liepa@umich.edu

Testing of

## Electromagnetic Emissions

per

USA: CFR Title 47, Part 15.231  
Canada: RSS-210 and RSS-Gen

are herein reported for

**TRW Automotive**  
**233661**

Test Report No.: 417124-663  
Copyright © 2013

Applicant/Provider:  
TRW Automotive

24175 Research Drive, Farmington Hills Michigan 4835-2642 USA  
Phone: +1 (248) 699-4487, Fax: +1 (248) 699-4241  
Contact Person: Mark Baker; mark.baker@trw.com

Report by:  Report Date of Issue: July 21, 2013  
Valdis V. Liepa, Ph.D.

---

**Results of testing completed on (or before) July 21, 2013 are as follows.**

**Emissions:** The transmitter fundamental emission meets the regulatory limit(s) by no less than 7.9 dB. Transmit chain spurious harmonic emissions comply by no less than 9.2 dB.

## Contents

<b>1</b>	<b>Test Specifications, General Procedures, and Location</b>	<b>3</b>
1.1	Test Specification and General Procedures . . . . .	3
1.2	Test Location and Equipment Used . . . . .	4
<b>2</b>	<b>Configuration and Identification of the Equipment Under Test</b>	<b>5</b>
2.1	Description and Declarations . . . . .	5
2.1.1	EUT Configuration . . . . .	5
2.1.2	Modes of Operation . . . . .	5
2.1.3	Variants . . . . .	6
2.1.4	Test Samples . . . . .	6
2.1.5	Functional Exerciser . . . . .	6
2.1.6	Modifications Made . . . . .	6
2.1.7	Production Intent . . . . .	6
2.1.8	Declared Exemptions and Additional Product Notes . . . . .	6
<b>3</b>	<b>Emissions</b>	<b>7</b>
3.1	General Test Procedures . . . . .	7
3.1.1	Radiated Test Setup and Procedures . . . . .	7
3.1.2	Conducted Emissions Test Setup and Procedures . . . . .	9
3.1.3	Power Supply Variation . . . . .	9
3.2	Intentional Emissions . . . . .	10
3.2.1	Fundamental Emission Pulsed Operation . . . . .	10
3.2.2	Fundamental Emission Bandwidth . . . . .	12
3.2.3	Fundamental Emission . . . . .	13
3.3	Unintentional Emissions . . . . .	14
3.3.1	Transmit Chain Spurious Emissions . . . . .	14

## List of Tables

1	The University of Michigan Radiation Laboratory Equipment List. . . . .	4
2	EUT Declarations. . . . .	5
3	Pulsed Emission Characteristics (Duty Cycle). . . . .	10
4	Intentional Emission Bandwidth. . . . .	12
5	Fundamental Radiated Emissions. . . . .	13
6	Transmit Chain Spurious Emissions. . . . .	14

## List of Figures

1	Photos of EUT. . . . .	5
2	EUT Test Configuration Diagram. . . . .	6
3	Radiated Emissions Diagram of the EUT. . . . .	7
4	Radiated Emissions Test Setup Photograph(s). . . . .	8
5	Pulsed Emission Characteristics (Duty Cycle). . . . .	10
5	Pulsed Emission Characteristics (Duty Cycle). . . . .	11
6	Intentional Emission Bandwidth. . . . .	12

# 1 Test Specifications, General Procedures, and Location

## 1.1 Test Specification and General Procedures

The ultimate goal of TRW Automotive is to demonstrate that the Equipment Under Test (EUT) complies with the Rules and/or Directives below. Detailed in this report are the results of testing the TRW Automotive 233661 for compliance to:

Country/Region	Rules or Directive	Referenced Section(s)
United States	Code of Federal Regulations	CFR Title 47, Part 15.231
Canada	Industry Canada	RSS-210 and RSS-Gen

In association with the rules and directives outlined above, the following specifications and procedures are followed herein.

ANSI C63.4-2003	"Methods of Measurement of Radio-Noise Emissions from Low-Voltage Electrical and Electronic Equipment in the Range of 9 kHz to 40 GHz"
Industry Canada	"The Measurement of Occupied Bandwidth"

## 1.2 Test Location and Equipment Used

**Test Location** The EUT was fully tested by **The University of Michigan Radiation Laboratory**, 3228 EECS Building, Ann Arbor, Michigan 48109-2122 USA. The Test Facility description and attenuation characteristics are on file with the FCC Laboratory, Columbia, Maryland (FCC Reg. No: 91050) and with Industry Canada, Ottawa, ON (File Ref. No: IC 2057A-1).

**Test Equipment** Pertinent test equipment used for measurements at this facility is listed in Table 1. The quality system employed at The University of Michigan Radiation Laboratory has been established to ensure all equipment has a clearly identifiable classification, calibration expiry date, and that all calibrations are traceable to the SI through NIST, other recognized national laboratories, accepted fundamental or natural physical constants, ratio type of calibration, or by comparison to consensus standards.

Table 1: The University of Michigan Radiation Laboratory Equipment List.

<b>Test Instrument</b>	<b>Manufacturer/Model</b>	<b>Q Number</b>
Spectrum Analyzer (9kHz-26GHz)	Hewlett-Packard 8593E, SN: 3412A01131	HP8593E1
Spectrum Analyzer (9kHz-6.5GHz)	Hewlett-Packard 8595E, SN: 3543A01546	JDB8595E
Power Meter	Hewlett-Packard, 432A	HP432A1
Harmonic Mixer (26-40 GHz)	Hewlett-Packard 11970A, SN: 3003A08327	HP11970A1
Harmonic Mixer (40-60 GHz)	Hewlett-Packard 11970U, SN: 2332A00500	HP11970U1
Harmonic Mixer (75-110 GHz)	Hewlett-Packard 11970W, SN: 2521A00179	HP11970W1
Harmonic Mixer (140-220 GHz)	Pacific Millimeter Prod., GMA, SN: 26	PMPGMA1
S-Band Std. Gain Horn	S/A, Model SGH-2.6	SBAND1
C-Band Std. Gain Horn	University of Michigan, NRL design	CBAND1
XN-Band Std. Gain Horn	University of Michigan, NRL design	XNBAND1
X-Band Std. Gain Horn	S/A, Model 12-8.2	XBAND1
X-band horn (8.2- 12.4 GHz)	Narda 640	XBAND2
X-band horn (8.2- 12.4 GHz)	Scientific Atlanta , 12-8.2, SN: 730	XBAND3
K-band horn (18-26.5 GHz)	FXR, Inc., K638KF	KBAND1
Ka-band horn (26.5-40 GHz)	FXR, Inc., U638A	KABAND1
U-band horn (40-60 GHz)	Custom Microwave, HO19	UBAND1
W-band horn(75-110 GHz)	Custom Microwave, HO10	WBAND1
G-band horn (140-220 GHz)	Custom Microwave, HO5R	GBAND1
Bicone Antenna (30-250 MHz)	University of Michigan, RLBC-1	LBBIC1
Bicone Antenna (200-1000 MHz)	University of Michigan, RLBC-2	HBBIC1
Dipole Antenna Set (30-1000 MHz)	University of Michigan, RLDP-1,-2,-3	UMDIP1
Dipole Antenna Set (30-1000 MHz)	EMCO 3121C, SN: 992 (Ref. Antennas)	EMDIP1
Active Rod Antenna (30 Hz-50 MHz)	EMCO 3301B, SN: 3223	EMROD1
Active Loop Antenna (30 Hz-50 MHz)	EMCO 6502, SN:2855	EMLOOP1
Ridge-horn Antenna (300-5000 MHz)	University of Michigan	UMRH1
Amplifier (5-1000 MHz)	Avantek, A11-1, A25-1S	AVAMP1
Amplifier (5-4500 MHz)	Avantek	AVAMP2
Amplifier (4.5-13 GHz)	Avantek, AFT-12665	AVAMP3
Amplifier (6-16 GHz)	Trek	TRAMP1
Amplifier (16-26 GHz)	Avantek	AVAMP4
LISN Box	University of Michigan	UMLISN1
Signal Generator	Hewlett-Packard 8657B	HPSG1

## 2 Configuration and Identification of the Equipment Under Test

### 2.1 Description and Declarations

The equipment under test is an automotive Tire Pressure Measurement (TPM) transmitter. The EUT is approximately 7 x 5 x 2 cm (approx.) in dimension, and is depicted in Figure 1. It is powered by a 3 VDC Lithium cell battery. In use, this device is permanently affixed as the valve-stem in the tire of a motor vehicle. Table 2 outlines provider declared EUT specifications.



Figure 1: Photos of EUT.

Table 2: EUT Declarations.

General Declarations			
<b>Equipment Type:</b>	TPM Transmitter	<b>Country of Origin:</b>	USA
<b>Nominal Supply:</b>	3 VDC	<b>Oper. Temp Range:</b>	Not Declared
<b>Frequency Range:</b>	315 MHz	<b>Antenna Dimension:</b>	5 x 0.7 cm (approx.)
<b>Antenna Type:</b>	tire stem	<b>Antenna Gain:</b>	< -24 dBi (declared)
<b>Number of Channels:</b>	1	<b>Channel Spacing:</b>	Not Applicable
<b>Alignment Range:</b>	315 ± 0.065 MHz	<b>Type of Modulation:</b>	FSK
United States			
<b>FCC ID Number:</b>	GQ4-66T	<b>Classification:</b>	DSC
Canada			
<b>IC Number:</b>	1470A-47T	<b>Classification:</b>	Remote Control Device, Vehicular Device

#### 2.1.1 EUT Configuration

The EUT is configured for testing as depicted in Figure 2.

#### 2.1.2 Modes of Operation

The EUT is capable of two key modes of operation. Upon manually activated LF interrogation (through the use of special LF tool at a vehicle dealership), the EUT responds with a single transmission containing a number of frames used to configure the device with the vehicle. When the EUT is placed in the vehicle tire and the vehicle drives, it can, in the worst case, periodically transmit where the duration of each transmission is always less than 1 second

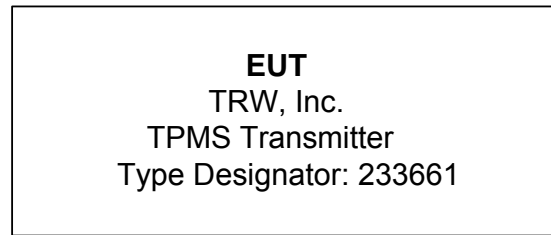

Figure 2: EUT Test Configuration Diagram.

and the silent period between transmissions is at least 30 times the duration of the transmission, and never less than 10 seconds.

### 2.1.3 Variants

There is only a single electrical variant of the EUT, as tested.

### 2.1.4 Test Samples

Three samples were provided for testing, two normal operating samples and one dismantled for photos.

### 2.1.5 Functional Exerciser

Normal operating EUT functionality was verified by observation of transmitted signal from EUT after LF activation.

### 2.1.6 Modifications Made

There were no modifications made to the EUT by this laboratory.

### 2.1.7 Production Intent

The EUT appears to be a production ready sample, but for whom's clamshell housings are not yet laser welded.

### 2.1.8 Declared Exemptions and Additional Product Notes

The EUT is permanently installed in a transportation vehicle. As such, digital emissions are exempt from US and Canadian digital emissions regulations (per FCC 15.103(a) and IC correspondence on ICES-003).

The EUT also employs some modes of operation that alert the vehicle user of sudden changes in tire pressure. Such alert modes fall under FCC 15.231(a)(4), and may operate during the pendency of the alarm condition. A detailed list of all operating modes is included in the Description of Operation exhibit included in this application.

### 3 Emissions

#### 3.1 General Test Procedures

##### 3.1.1 Radiated Test Setup and Procedures

Radiated electromagnetic emissions from the EUT are first evaluated in our shielded fully anechoic chamber. Spectrum and modulation characteristics of all emissions are recorded, and emissions above 1 GHz are fully characterized. The anechoic chamber contains a set-up similar to that of our outdoor 3-meter site, with a turntable and antenna mast. Instrumentation, including spectrum analyzers and other test equipment as detailed in Section 1.2 are employed. After indoor pre-scans, emission measurements are made on our outdoor 3-meter Open Area Test Site (OATS). If the EUT connects to auxiliary equipment and is table or floor standing, the configurations prescribed in ANSI C63.4 / CISPR-22 are followed. Alternatively, a layout closest to normal use (as declared by the provider) is employed if the resulting emissions appear to be worst-case in such a configuration. See Figure 3. All

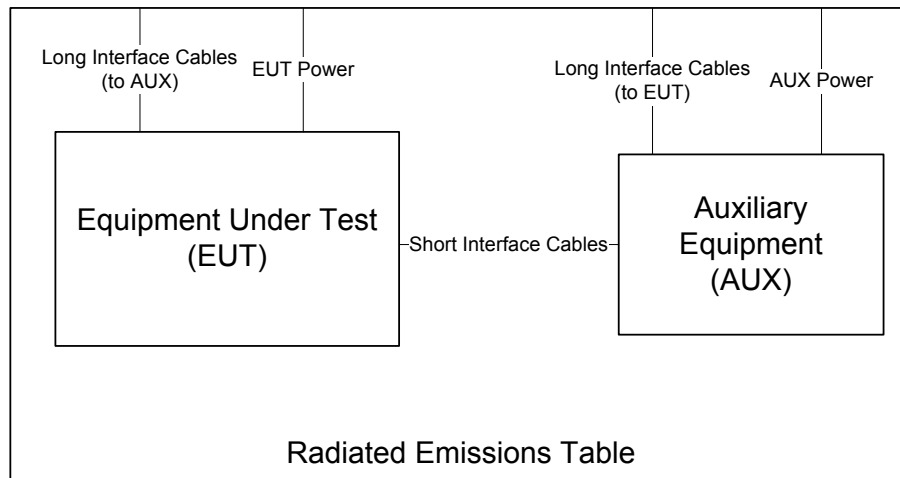

Figure 3: Radiated Emissions Diagram of the EUT.

intentionally radiating elements are placed on the test table lying flat, on their side, and on their end (3-axes) and the resulting worst case emissions are recorded. For both horizontal and vertical polarizations, the test antenna is raised and lowered from 1 to 4 m in height until a maximum emission level is detected. The EUT is then rotated through 360° in azimuth until the highest emission is detected. The test antenna is then raised and lowered one last time from 1 to 4 m and the worst case value is recorded. Photographs of the test setup employed are depicted in Figure 4.

If the EUT exhibits spurious emissions due to internal receiver circuitry, such emissions are measured with an appropriate carrier signal applied. For devices with intentional emissions below 30 MHz, a shielded loop antenna is used as the test antenna. It is placed at a 1 meter receive height and appropriate low frequency magnetic field extrapolation to the regulatory limit distance is employed. Emissions between 30 MHz and 1 GHz are measured using tuned dipoles and/or calibrated broadband antennas. Emissions above 1 GHz are characterized using standard gain horn antennas or calibrated broadband ridge-horn antennas. Care is taken to ensure that test receiver resolution and video bandwidths meet the regulatory requirements, and that the emission bandwidth of the EUT is not reduced.

Where regulations allow for direct measurement of field strength, power values (dBm) measured on the test receiver / analyzer are converted to dBμV/m at the regulatory distance, using

$$E_{dist} = 107 + P_R + K_A - K_G + K_E - C_F$$

where  $P_R$  is the power recorded on spectrum analyzer, in dBm,  $K_A$  is the test antenna factor in dB/m,  $K_G$  is the combined pre-amplifier gain and cable loss in dB,  $K_E$  is duty correction factor (when applicable) in dB, and  $C_F$  is a distance conversion (employed only if limits are specified at alternate distance) in dB. This field strength value is then compared with the regulatory limit. If effective isotropic radiated power (EIRP) is compute, it is computed as

$$EIRP(dBm) = E_{3m}(dB\mu V/m) - 95.2.$$



When presenting data at each frequency, the highest measured emission under all possible EUT orientations (3-axes) is reported.



Figure 4: Radiated Emissions Test Setup Photograph(s).



### 3.1.2 Conducted Emissions Test Setup and Procedures

**Battery Power Conducted Spurious** The EUT is not subject to measurement of power line conducted emissions as it is powered solely by its internal battery.

### 3.1.3 Power Supply Variation

Tests at extreme supply voltages are made if required by the the procedures specified in the test standard, and results of this testing are detailed in this report.

In the case the EUT is designed for operation from a lead-acid battery power source, the extreme test voltages are evaluated between 90% and 130% of the nominal battery voltage declared by the manufacturer. For float charge applications using gel-cell type batteries, extreme test voltages are evaluated between 85% and 115% of the nominal battery voltage declared. For all battery operated equipment, worst case intentional and spurious emissions are re-checked employing a new (fully charged) battery.

### 3.2 Intentional Emissions

#### 3.2.1 Fundamental Emission Pulsed Operation

The details and results of testing the EUT for pulsed operation are summarized in Table 3. Plots showing the measurements made to obtain these values are provided in Figure 5.

Table 3: Pulsed Emission Characteristics (Duty Cycle).

When the transmitter is activated (by LF encoded manual activation or when periodically transmitting due to tire rotation), it can, in the worst case, transmit two 7.75 ms words within any given 100 ms window. See the following Figure. Computing the duty factor results in:

Duty Cycle Computation		TRW TPMS; FCC/IC					
1	KE = (2 x 7.75 ms) / 100 ms = 0.155 or -16.2 dB						
2							

Meas. U. of Mich, 5/29/2013

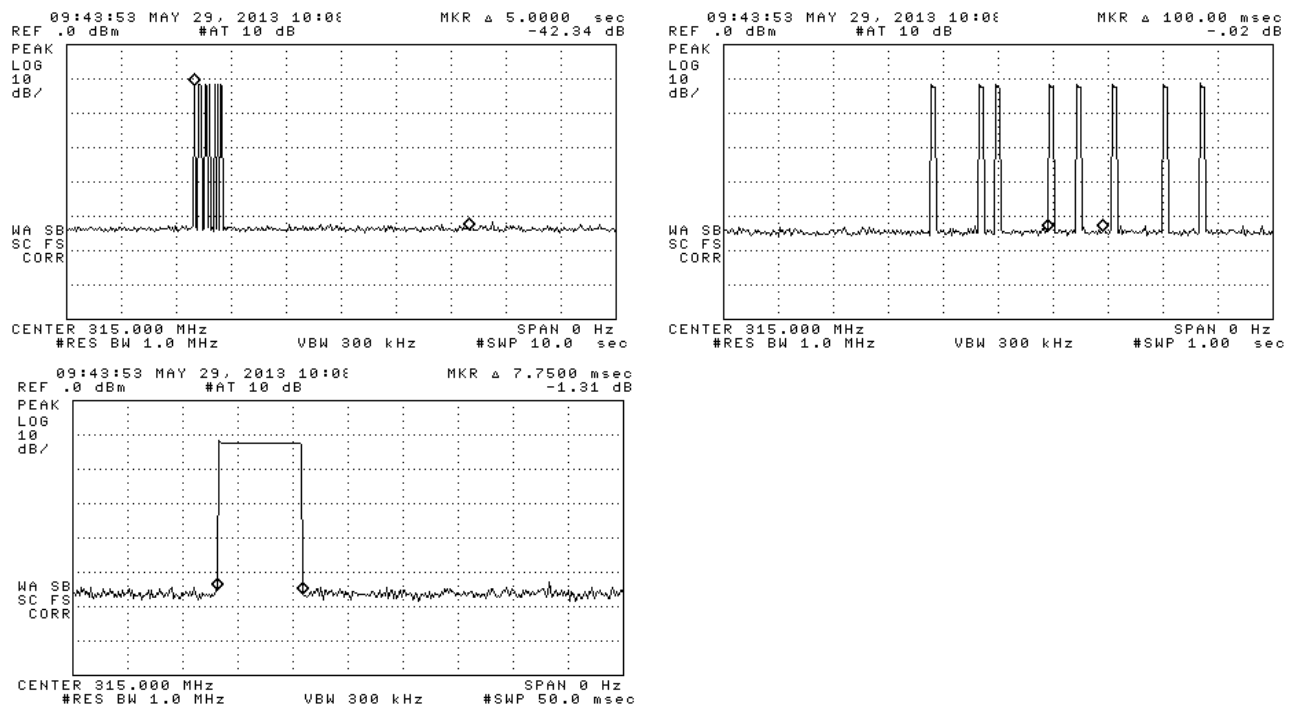

Figure 5(a): Pulsed Emission Characteristics (Duty Cycle).

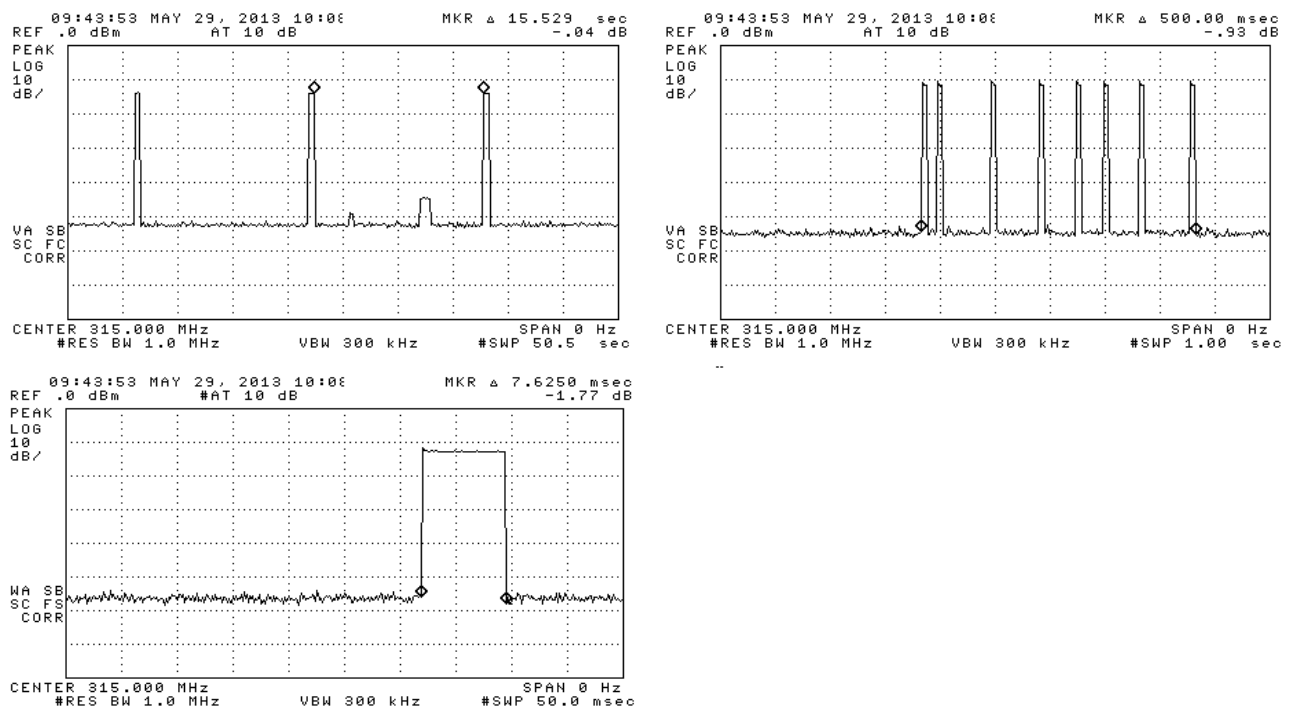

Figure 5(b): Pulsed Emission Characteristics (Duty Cycle).

### 3.2.2 Fundamental Emission Bandwidth

Emission bandwidth (EBW) of the EUT is measured with the device placed in the test mode(s) with the shortest available frame length and minimum frame spacing. Radiated emissions are recorded following the test procedures listed in Section 1.1. The 20 dB EBW is measured as the max-held peak-detected signal when the IF bandwidth is greater than or equal to 1% of the receiver span. For complex modulations other than ASK and FSK, the 99% emission bandwidth per IC test procedures has a different result, and is also separately reported. The results of EBW testing are summarized in Table 4. Plots showing measurements employed to obtain the emission bandwidth reported are provided in Figure 6.

Table 4: Intentional Emission Bandwidth.

The emission bandwidth of the signal is shown in the following Figure. The allowed 99% bandwidth is 0.25% of 315 MHz, or 787.25 kHz.

Measured Emission Bandwidth				TRW TPMS; FCC/IC			
#	EBW meas. (kHz)						
1	125.0						

Meas. U. of Mich, 5/29/2013

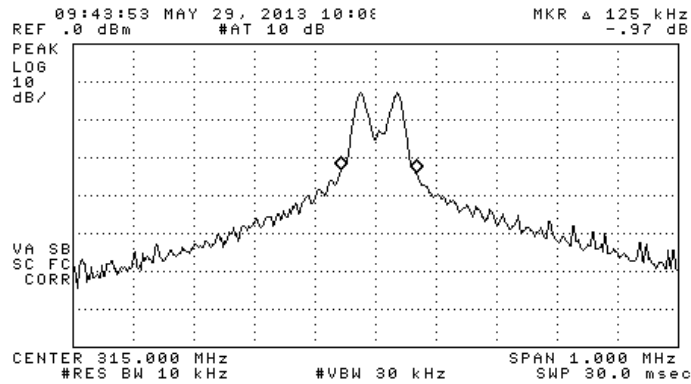

Figure 6: Intentional Emission Bandwidth.

### 3.2.3 Fundamental Emission

Following the test procedures listed in Section 1.1, radiated emissions measurements are made on the EUT for both Horizontal and Vertical polarized fields. Table 5 details the results of these measurements.

Table 5: Fundamental Radiated Emissions.

<b>Radiated Emission - RF TPM</b>											TRW, HKMC LM/SL FL; FCC/IC	
#	Freq. MHz	Ant. Used	Ant. Pol.	Pr dBm	Det. Used	Ka dB/m	Kg dB	E3* dB $\mu$ V/m	E3lim dB $\mu$ V/m	Pass dB	Comments	
1	315.0	Dip	H	-29.0	Pk	18.6	20.6	59.8	67.7	<b>7.9</b>	flat	(4E1633B3)
2	315.0	Dip	V	-34.1	Pk	18.6	20.6	54.7	67.7	13.0	end	
3												
4												
5												
6												
7												
8												
9	* Includes 16.2 dB Duty Cycle											
10												
11												
12												
13												
14												

### 3.3 Unintentional Emissions

#### 3.3.1 Transmit Chain Spurious Emissions

The results for the measurement of transmit chain spurious emissions at the nominal voltage and temperature are provided in Table 6. Measurements are performed to 10 times the highest fundamental operating frequency.

Table 6: Transmit Chain Spurious Emissions.

<b>Radiated Emission - RF TPM</b>										TRW, HKMC LM/SL; FCC/IC	
#	Freq. MHz	Ant. Used	Ant. Pol.	Pr dBm	Det. Used	Ka dB/m	Kg dB	E3* dB $\mu$ V/m	E3lim dB $\mu$ V/m	Pass dB	Comments
1	630.0	Dip	H	-74.1	Pk	24.4	17.5	23.6	47.7	24.1	side
2	630.0	Dip	V	-73.0	Pk	24.4	17.5	24.7	47.7	23.0	end
3	945.0	Dip	H	-76.6	Pk	28.8	15.5	27.5	47.7	20.2	flat
4	945.0	Dip	V	-80.7	Pk	28.8	15.5	23.4	47.7	24.3	end
5	1260.0	Horn	H	-38.5	Pk	20.6	28.1	44.8	54.0	<b>9.2</b>	flat
6	1575.0	Horn	H	-44.0	Pk	21.5	28.1	40.2	54.0	13.8	side
7	1890.0	Horn	H	-60.3	Pk	22.2	28.1	24.6	54.0	29.4	side
8	2205.0	Horn	H	-63.3	Pk	23.0	26.5	24.0	54.0	30.0	side
9	2520.0	Horn	H	-65.5	Pk	23.9	26.0	23.2	54.0	30.8	side
10	2835.0	Horn	H	-70.0	Pk	24.8	24.7	20.9	54.0	33.1	side
11	3150.0	Horn	H	-70.5	Pk	25.8	23.6	22.5	54.0	31.5	side
12											
18											
23											
24	* Includes 16.2 dB Duty Cycle										
25											