



TEST REPORT

Report No.:	E20190319878502-1	Application No.:	E20190319878502
Applicant:	GEMMY INDUSTRIES (HK)LIMITED BVI		
Address:	No.301 on 3rd Floor, East Ocean Centre, No.98 Granville Road, Kowloon, Hong Kong		
Sample Description:	AppLights Lightshow Projection		
Model:	117027		
Adding Model:	/		
FCC ID:	GPO117027		
Test Specification:	FCC 47 CFR Part 15 Subpart C		
Test Date:	2019-04-02 to 2019-04-16		
Issue Date:	2019-04-26		
Test Result:	PASS		
Prepared By:	Reviewed By:	Approved By:	
Darry Wu / Test Engineer	Eve Wang / Technical Manager	Tony Han / Manager	
Date:2019-04-26	Date:2019-04-26	Date:2019-04-26	
Other Aspects:			
/			
<i>Abbreviations: ok / P = passed; fail / F = failed; n.a. / N = not applicable</i>			
The test result in this test report refers exclusively to the presented test sample. This report shall not be reproduced except in full, without the written approval of GRGT.			

DIRECTIONS OF TEST

1. This company carries out test task according to the national regulation of verifications which can be traced to National Primary Standards and BIPM.
2. The test report merely corresponds to the test sample. It is not permitted to copy extracts of these test result without the written permission of the test laboratory.
3. If there is any objection concerning the test, the client should inform the laboratory within 15 days from the date of receiving the test report.

TABLE OF CONTENTS

1. TEST RESULT SUMMARY	4
2. GENERAL DESCRIPTION OF EUT.....	5
2.1. APPLICANT	5
2.2. MANUFACTURER	5
2.3. FACTORY	5
2.4. BASIC DESCRIPTION OF EQUIPMENT UNDER TEST	5
2.5. TEST OPERATION MODE	6
2.6. LOCAL SUPPORTIVE.....	6
3. LABORATORY AND ACCREDITATIONS	7
3.1. LABORATORY	7
3.2. ACCREDITATIONS.....	7
3.3. MEASUREMENT UNCERTAINTY	7
4. LIST OF USED TEST EQUIPMENT AT GRGT.....	8
5. ANTENNA REQUIREMENT	9
6. CONDUCTED EMISSION MEASUREMENT	10
6.1. LIMITS.....	10
6.2. TEST PROCEDURES.....	10
6.3. TEST SETUP	11
6.4. DATA SAMPLE	11
6.5. TEST RESULTS	12
7. RADIATED SPURIOUS EMISSIONS	14
7.1. LIMITS.....	14
7.2. TEST PROCEDURES (PLEASE REFER TO MEASUREMENT STANDARD).....	14
7.3. TEST SETUP	18
7.4. DATA SAMPLE	19
7.5. TEST RESULTS	20
8. 6DB BANDWIDTH.....	24
8.1. LIMITS.....	24
8.2. TEST PROCEDURES.....	24
8.3. TEST SETUP	24
8.4. TEST RESULTS	24
9. MAXIMUM PEAK OUTPUT POWER.....	27
9.1. LIMITS	27
9.2. TEST PROCEDURES	27
9.3. TEST SETUP	27
9.4. TEST RESULTS	27
10. POWER SPECTRAL DENSITY.....	28
10.1. LIMITS.....	28
10.2. TEST PROCEDURES.....	28
10.3. TEST SETUP	28
10.4. TEST RESULTS	28
11. CONDUCTED BAND EDGES AND SPURIOUS EMISSIONS	31
11.2. LIMITS.....	31
11.3. TEST PROCEDURES.....	31
11.4. TEST SETUP	31
11.5. TEST RESULTS	32
12. RESTRICTED BANDS OF OPERATION.....	35
12.1. LIMITS.....	35
12.2. TEST PROCEDURES.....	35
12.3. TEST SETUP	36
12.4. TEST RESULTS	37

1. TEST RESULT SUMMARY

Section B of FCC Part 15.247:2012			
Standard	Item	Limit / Severity	Result
FCC Part 15,Subpart C (15.247)	Antenna Requirement	§15.203	PASS
	Conducted Emissions	§15.207 (a)	PASS
	Radiated Spurious Emission	§15.247(d)	PASS
	6 dB Bandwidth	§15.247 (a)(2)	PASS
	Maximum Peak Output Power	§15.247(b)(3)	PASS
	Power Spectral Density	§15.247(e)	PASS
	Conducted band edges and Spurious Emission	§15.247(d)	PASS
	Restricted bands of operation	§15.205	PASS

2. GENERAL DESCRIPTION OF EUT

2.1. APPLICANT

Name: GEMMY INDUSTRIES (HK)LIMITED BVI
Address: No.301 on 3rd Floor, East Ocean Centre, No.98 Granville Road, Kowloon, Hong Kong

2.2. MANUFACTURER

Name: GEMMY INDUSTRIES (HK)LIMITED BVI
Address: No.301 on 3rd Floor, East Ocean Centre, No.98 Granville Road, Kowloon, Hong Kong

2.3. FACTORY

Factory 1

Name : ZAIXING ELECTRONIC (SHENZHEN)CO., LTD.
Address : 3#, 1st Road Yang Yong, Shapu Community, Songgang, Baoan District, Shenzhen City, Guangdong Province, China.

Factory 2

Name : DynaTech Co. Ltd
Address : 259-261 Xincheng Road, Qiaotou Town, Dongguan, Guangdong, China

Factory 3

Name : YUAN HONG CO., LTD
Address : No. 3, meichun A industrial zone, meichun fang, fumei city, Ba Ria Vung Tau Province, Vietnam.

2.4. BASIC DESCRIPTION OF EQUIPMENT UNDER TEST

Equipment: AppLights Lightshow Projection
Model No.: 117027
Adding Model: /
Model /
Discrepancy:
Trade Name: /
Power supply: AC120V/60Hz
Frequency 2402 ~ 2480 MHz
Range:
Transmit -1.58dBm
Power:
Modulation GFSK for 1Mbps
type:
Channel space: 2MHz
Antenna Monopole Antenna with 4.0 dBi gain (Max)

Specification:

Temperature Range: -20~70°C
 Hardware Version: 117027-USA (V1)
 Software Version: 117027-USA (V1)
 Note: /

2.5. TEST OPERATION MODE

Test Item	Mode No.	Description of the modes
Conducted Emission	1	Four color lights flashing
Radiated Emission	1	Continuously Transmitting

2.6. LOCAL SUPPORTIVE

Name of Equipment	Manufacturer	Model	Serial Number	Note
/	/	/	/	/
Cable				
/	/	/	/	/

Test software:

Software version	Test level
BTOOL	40

3. LABORATORY AND ACCREDITATIONS

3.1. LABORATORY

The tests and measurements refer to this report were performed by EMC Laboratory of GRG METROLOGY & TEST (SHENZHEN) CO., LTD

Add. : No.1301 Guanguang Road Xinlan Community, Guanlan Street, Longhua District Shenzhen, 518110, People's Republic of China

Telephone : +86-755-61180008

Fax : /

3.2. ACCREDITATIONS

A2LA	Certificate Number 2861.01
------	----------------------------

3.3. MEASUREMENT UNCERTAINTY

Where relevant, the following measurement uncertainty levels have been estimated for tests performed on the EUT as specified in CISPR 16-4-2:

Measurement		Frequency	Uncertainty
Radiated Emission	Horizontal	30MHz~1000MHz	4.8dB
		1GHz~26.5GHz	5.8dB
	Vertical	30MHz~1000MHz	4.8dB
		1GHz~26.5GHz	5.9dB
Conducted Emission		9kHz~30MHz	3.5dB

This uncertainty represents an expanded uncertainty factor of $k=2$.

4. LIST OF USED TEST EQUIPMENT AT GRGT

Name of Equipment	Manufacturer	Model	Serial Number	Calibration Due
Conducted Emissions				
EMI TEST Receiver	ROHDE&SCHWARZ	ESCI	100783	2020-01-10
LISN(EUT)	ROHDE&SCHWARZ	ENV216	101543	2020-01-10
Hygrothermograph	VICTOR	HTC-1	N/A	2019-12-25
Test S/W	FARAD	EZ-EMC/ CCS-3A1-CE		
Radiated Spurious Emission& Restricted bands of operation				
ESPI Test Receiver	ROHDE&SCHWARZ	ESPI	101026	2020-01-09
EXA signal analyzer	Agilent	N9010A	MY52221469	2020-01-10
Bilog Antenna	Schwarzbeck	VULB 9160	9160-3401	2019-12-21
Horn Antenna	Schwarzbeck	BBHA9120	D286	2019-12-21
Board-Band Horn Antenna	Schwarzbeck	BBHA9170	9170-497	2020-01-15
Active Loop Antenna	COM-POWER	AL-130	121044	2019-12-27
Amplifier	EM Electronics Corporation	EM330	060661	2019-12-21
High Noise Amplifier	Agilent	8449B	3008A02060	2019-12-21
Hygrothermograph	VICTOR	HTC-1	NA	2019-12-24
Test SW	FARAD	EZ-EMC/ CCS-3A1-CE		
6 dB Bandwidth				
EXA signal analyzer	Agilent	N9010A	MY52221469	2020-01-10
Maximum Peak Output Power				
EXA signal analyzer	Agilent	N9010A	MY52221469	2020-01-10
Conducted band edges and Spurious Emission				
EXA signal analyzer	Agilent	N9010A	MY52221469	2020-01-10
Power Spectral Density				
EXA signal analyzer	Agilent	N9010A	MY52221469	2020-01-10

5. ANTENNA REQUIREMENT

The EUT has one antenna. The antenna is Monopole antenna.

The max gain of antenna is 4dBi .which accordance 15.203.is considered sufficient to comply with the provisions of this section

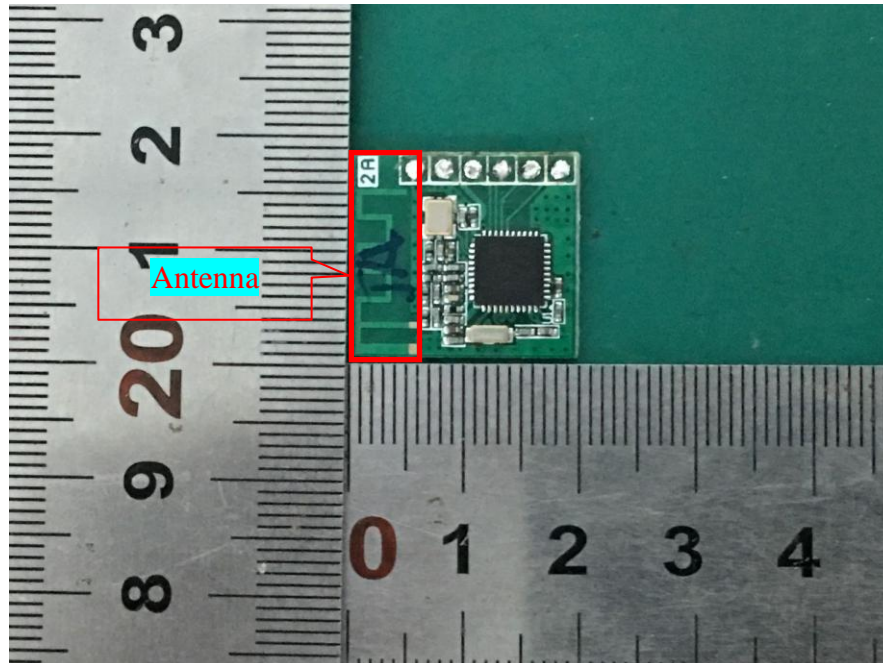

6. CONDUCTED EMISSION MEASUREMENT

6.1. LIMITS

Frequency range	Limits (dB μ V)	
	Quasi-peak	Average
150kHz ~ 0.5MHz	66~56	56~46
0.5 MHz ~ 5 MHz	56	46
5 MHz ~ 30 MHz	60	50

NOTE: (1) The lower limit shall apply at the transition frequencies.

(2) The limit decreases in line with the logarithm of the frequency in the range of 150 kHz to 0.5MHz.

6.2. TEST PROCEDURES

Procedure of Preliminary Test

Test procedures follow ANSI C63.4:2014.

For measurement of the disturbance voltage the equipment under test (EUT) is connected to the power supply mains and any other extended network via one or more artificial network(s). An EUT, whether intended to be grounded or not, and which is to be used on a table is configured as follows:

- Either the bottom or the rear of the EUT shall be at a controlled distance of 40 cm from a reference ground plane. This ground plane is normally the wall or floor of a shielded room. It may also be a grounded metal plane of at least 2 m by 2 m. This is physically accomplished as follows:
 - 1) place the EUT on a table of non-conducting material which is at least 80 cm high. Place the EUT so that it is 40 cm from the wall of the shielded room, or
 - 2) place the EUT on a table of non-conducting material which is 40 cm high so that the bottom of the EUT is 40 cm above the ground plane;
- All other conductive surfaces of the EUT shall be at least 80 cm from the reference ground plane;
- The EUT are placed on the floor that one side of the housings is 40 cm from the vertical reference ground plane and other metallic parts;
- Interconnecting cables that hang closer than 40 cm to the ground plane shall be folded back and forth forming a bundle 30 cm to 40 cm long, hanging approximately in the middle between the ground plane and the table.
- I/O cables that are connected to a peripheral shall be bundled in the centre. The end of the cable may be terminated if required using correct terminating impedance. The total length shall not exceed 1 m.

The test mode(s) described in Item 2.4 were scanned during the preliminary test. After the preliminary scan, we found the test mode described in Item 2.4 producing the highest emission level. The EUT configuration and cable configuration of the above highest emission levels were recorded for reference of the final test.

Procedure of Final Test

EUT and support equipment were set up on the test bench as per the configuration with highest emission level in the preliminary test. A scan was taken on both power lines, recording at least the six highest emissions. Emission frequency and amplitude were recorded into a computer in which correction factors were used to calculate the emission level and compare reading to the applicable limit. The test data of the worst-case condition(s) was recorded.

6.3. TEST SETUP

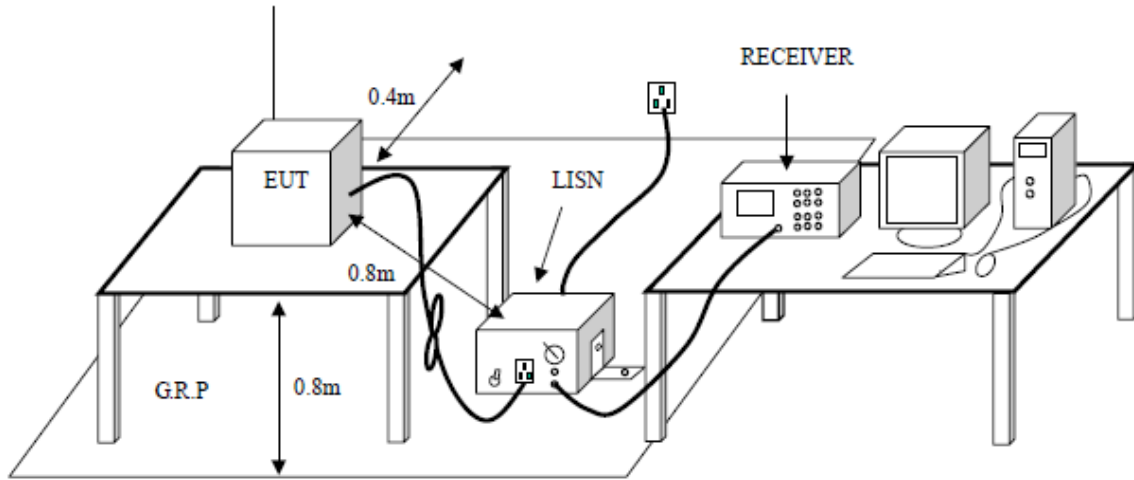

6.4. DATA SAMPLE

Frequency (MHz)	QuasiPeak Reading (dBuV)	Average Reading (dBuV)	Correction Factor (dB)	QuasiPeak Result (dBuV)	Average Result (dBuV)	QuasiPeak Limit (dBuV)	Average Limit (dBuV)	QuasiPeak Margin (dB)	Average Margin (dB)	Remark (Pass/Fail)
X.XXXX	32.69	25.65	11.52	44.21	37.17	65.78	55.79	-21.57	-18.62	Pass

- Factor = Insertion loss of LISN + Cable Loss
- Result = Quasi-peak Reading/ Average Reading + Factor
- Limit = Limit stated in standard
- Margin = Result (dBuV) – Limit (dBuV)

6.5. TEST RESULTS

Model No.	117027	RBW,VBW	9 kHz
Environmental Conditions	25.3°C, 48%RH	Test Mode	Mode 1
Tested By	Luja Huang	Line	L
Tested Date	2019-04-02	Test Voltage	AC120V/60Hz

(The chart below shows the highest readings taken from the final data.)

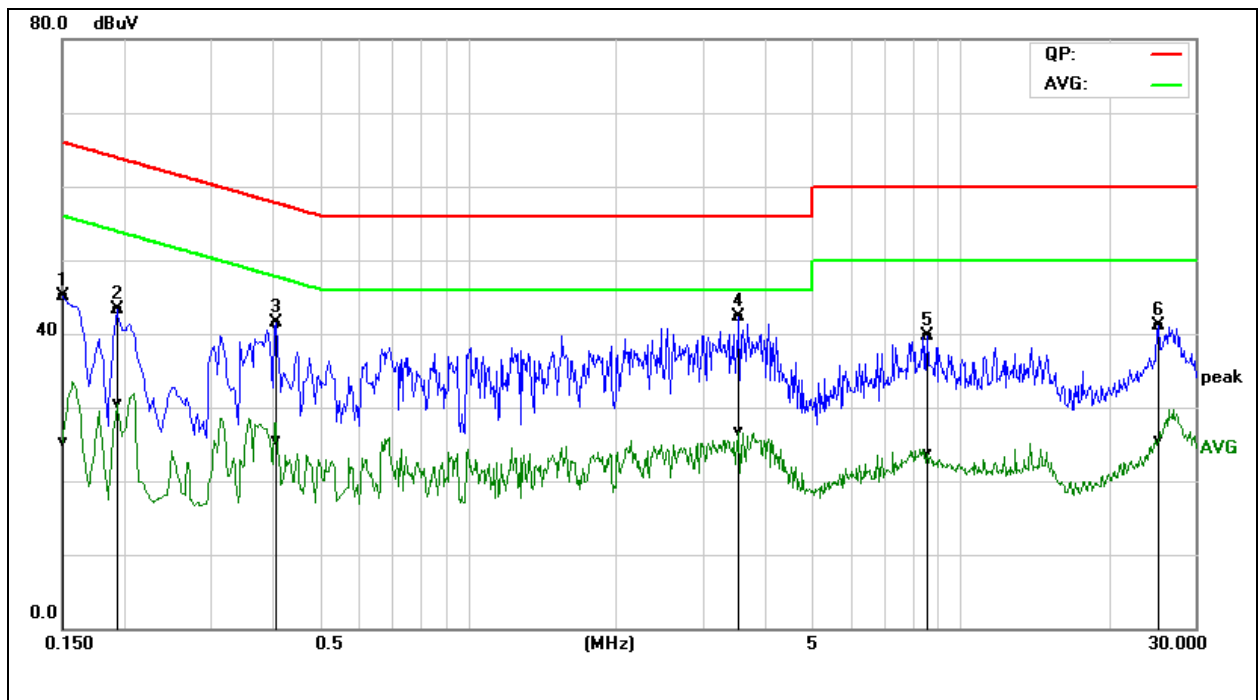

Frequency (MHz)	QuasiPeak Reading (dBuV)	Average Reading (dBuV)	Correction Factor (dB)	QuasiPeak Result (dBuV)	Average Result (dBuV)	QuasiPeak Limit (dBuV)	Average Limit (dBuV)	QuasiPeak Margin (dB)	Average Margin (dB)	Remark (Pass/Fail)
0.1500	25.17	5.33	19.88	45.05	25.21	65.99	56.00	-20.94	-30.79	Pass
0.1940	23.45	10.56	19.86	43.31	30.42	63.86	53.86	-20.55	-23.44	Pass
0.4100	21.58	5.78	19.82	41.40	25.60	57.65	47.65	-16.25	-22.05	Pass
3.5580	22.44	6.71	19.93	42.37	26.64	56.00	46.00	-13.63	-19.36	Pass
8.5620	19.72	3.60	20.08	39.80	23.68	60.00	50.00	-20.20	-26.32	Pass
25.2620	21.17	5.66	19.84	41.01	25.50	60.00	50.00	-18.99	-24.50	Pass

REMARKS: L = Live Line

Model No.	117027	RBW,VBW	9 kHz
Environmental Conditions	25.3°C, 48%RH	Test Mode	Mode 1
Tested By	Luja Huang	Line	N
Tested Date	2019-04-02	Test Voltage	AC120V/60Hz

(The chart below shows the highest readings taken from the final data.)

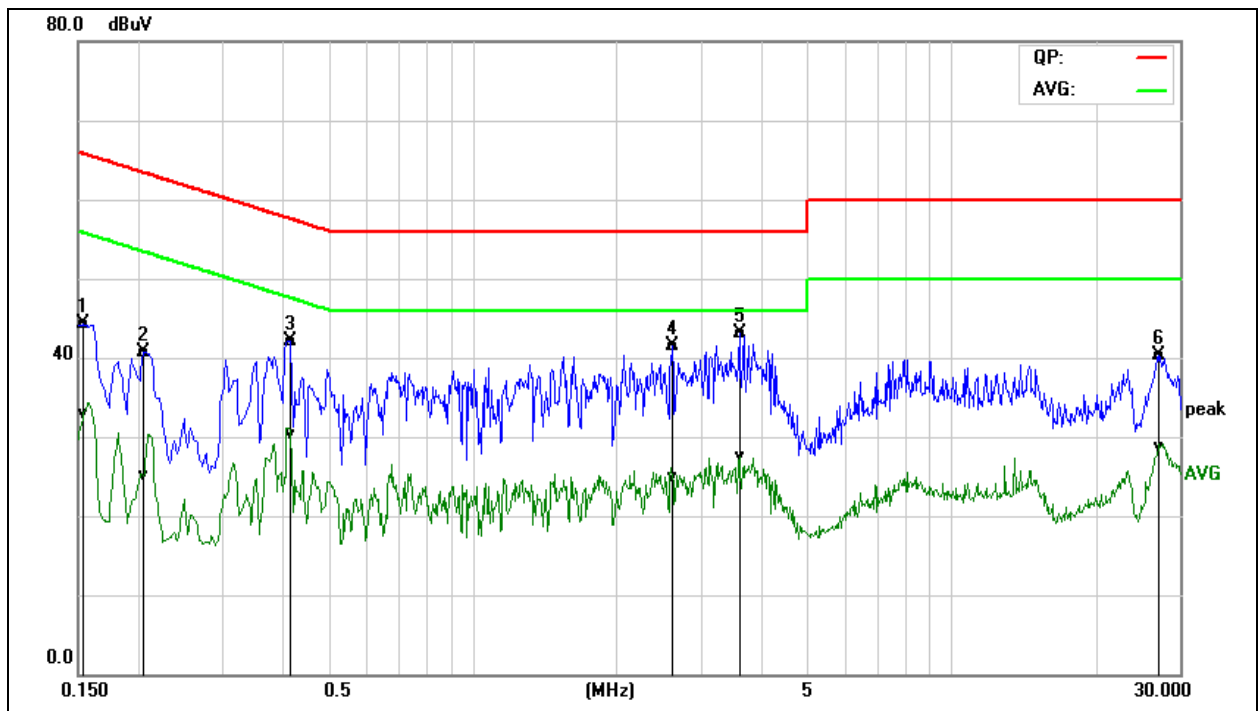

Frequency (MHz)	QuasiPeak Reading (dBuV)	Average Reading (dBuV)	Correction Factor (dB)	QuasiPeak Result (dBuV)	Average Result (dBuV)	QuasiPeak Limit (dBuV)	Average Limit (dBuV)	QuasiPeak Margin (dB)	Average Margin (dB)	Remark (Pass/Fail)
0.1539	24.38	13.06	19.86	44.24	32.92	65.78	55.79	-21.54	-22.87	Pass
0.2060	20.89	5.31	19.84	40.73	25.15	63.36	53.37	-22.63	-28.22	Pass
0.4180	22.35	10.45	19.82	42.17	30.27	57.49	47.49	-15.32	-17.22	Pass
2.6180	21.65	5.03	19.91	41.56	24.94	56.00	46.00	-14.44	-21.06	Pass
3.6140	23.19	7.59	19.92	43.11	27.51	56.00	46.00	-12.89	-18.49	Pass
27.1180	20.39	8.81	19.86	40.25	28.67	60.00	50.00	-19.75	-21.33	Pass

REMARKS: N = Neutral Line.

7. RADIATED SPURIOUS EMISSIONS

7.1. LIMITS

In any 100 kHz bandwidth outside the frequency band in which the spread spectrum or digitally modulated intentional radiator is operating, the radio frequency power that is produced by the intentional radiator shall be at least 20 dB below that in the 100 kHz bandwidth within the band that contains the highest level of the desired power, based on either an RF conducted or a radiated measurement, provided the transmitter demonstrates compliance with the peak conducted power limits. If the transmitter complies with the conducted power limits based on the use of RMS averaging over a time interval, as permitted under paragraph (b)(3) of this section, the attenuation required under this paragraph shall be 30 dB instead of 20 dB. Attenuation below the general limits specified in §15.209(a) is not required.

Frequency (MHz)	Quasi-peak($\mu\text{V}/\text{m}$)	Measurement distance(m)	Quasi-peak($\text{dB}\mu\text{V}/\text{m}$)@distance 3m
0.009-0.490	2400/F(kHz)	300	53.8~88.5
0.490-1.705	24000/F(kHz)	30	43~53.8
1.705-30.0	30	30	49.5
30 ~ 88	100	3	40
88~216	150	3	43.5
216 ~ 960	200	3	46
Above 960	500	3	54

NOTE: (1) The lower limit shall apply at the transition frequencies.

7.2. TEST PROCEDURES (please refer to measurement standard)

1) Sequence of testing 9 kHz to 30 MHz

Setup:

- The equipment was set up to simulate a typical usage like described in the user manual or described by manufacturer.
- If the EUT is a tabletop system, a rotatable table with 0.8 m height is used.
- If the EUT is a floor standing device, it is placed on the ground.
- Auxiliary equipment and cables were positioned to simulate normal operation conditions.
- The AC power port of the EUT (if available) is connected to a power outlet below the turntable.
- The measurement distance is 3 meter.
- The EUT was set into operation.

Pre measurement:

- The turntable rotates from 0° to 315° using 45° steps.
- The antenna height is 0.8 meter.
- At each turntable position the analyzer sweeps with peak detection to find the maximum of all emissions

Final measurement:

- Identified emissions during the pre measurement the software maximizes by rotating the turntable position (0° to 360°) and by rotating the elevation axes (0° to 360°).
- The final measurement will be done in the position (turntable and elevation) causing the highest emissions with QPK detector.
- The final levels, frequency, measuring time, bandwidth, turntable position, correction factor, margin to the limit and limit will be recorded. Also a plot with the graph of the pre measurement and the limit will be stored.

2) Sequence of testing 30 MHz to 1 GHz**Setup:**

- The equipment was set up to simulate a typical usage like described in the user manual or described by manufacturer.
- If the EUT is a tabletop system, a table with 0.8 m height is used, which is placed on the ground plane.
- If the EUT is a floor standing device, it is placed on the ground plane with insulation between both.
- Auxiliary equipment and cables were positioned to simulate normal operation conditions
- The AC power port of the EUT (if available) is connected to a power outlet below the turntable.
- The measurement distance is 3 meter.
- The EUT was set into operation.

Pre measurement:

- The turntable rotates from 0° to 315° using 45° steps.
- The antenna is polarized vertical and horizontal.
- The antenna height changes from 1 to 3 meter.
- At each turntable position, antenna polarization and height the analyzer sweeps three times in peak to find the maximum of all emissions.

Final measurement:

- The final measurement will be performed with minimum the six highest peaks.
- According to the maximum antenna and turntable positions of premeasurement the software maximize the peaks by changing turntable position ($\pm 45^\circ$) and antenna movement between 1 and 4 meter.
- The final measurement will be done with QP detector with an EMI receiver.
- The final levels, frequency, measuring time, bandwidth, antenna height, antenna polarization, turntable angle, correction factor, margin to the limit and limit will be recorded. Also a plot with the graph of the premeasurement with marked maximum final measurements and the limit will be stored.

3) Sequence of testing 1 GHz to 18 GHz**Setup:**

- The equipment was set up to simulate a typical usage like described in the user manual or described by manufacturer.
- If the EUT is a tabletop system, a rotatable table with 1.5 m height is used.
- If the EUT is a floor standing device, it is placed on the ground plane with insulation between both.
- Auxiliary equipment and cables were positioned to simulate normal operation conditions
- The AC power port of the EUT (if available) is connected to a power outlet below the turntable.
- The measurement distance is 3 meter.
- The EUT was set into operation.

Pre measurement:

- The turntable rotates from 0° to 315° using 45° steps.
- The antenna is polarized vertical and horizontal.
- The antenna height scan range is 1 meter to 2.5 meter.
- At each turntable position and antenna polarization the analyzer sweeps with peak detection to find the maximum of all emissions.

Final measurement:

- The final measurement will be performed with minimum the six highest peaks.
- According to the maximum antenna and turntable positions of premeasurement the software maximize the peaks by changing turntable position ($\pm 45^\circ$) and antenna movement between 1 and 4 meter. This procedure is repeated for both antenna polarizations.
- The final measurement will be done in the position (turntable, EUT-table and antenna polarization) causing the highest emissions with Peak and Average detector.
- The final levels, frequency, measuring time, bandwidth, turntable position, EUT-table position, antenna polarization, correction factor, margin to the limit and limit will be recorded. Also a plot with the graph of the pre measurement with marked maximum final measurements and the limit will be stored.

4) Sequence of testing above 18 GHz**Setup:**

- The equipment was set up to simulate a typical usage like described in the user manual or described by manufacturer.
- If the EUT is a tabletop system, a rotatable table with 1.5 m height is used.
- If the EUT is a floor standing device, it is placed on the ground plane with insulation between both.
- Auxiliary equipment and cables were positioned to simulate normal operation conditions
- The AC power port of the EUT (if available) is connected to a power outlet below the turntable.
- The measurement distance is 1 meter.
- The EUT was set into operation.

Pre measurement:

- The antenna is moved spherical over the EUT in different polarisations of the antenna.

Final measurement:

- The final measurement will be performed at the position and antenna orientation for all detected emissions that were found during the premeasurements with Peak and Average detector.
- The final levels, frequency, measuring time, bandwidth, correction factor, margin to the limit and limit will be recorded. Also a plot with the graph of the premeasurement and the limit will be stored.

NOTE: The resolution bandwidth of test receiver/spectrum analyzer is 1MHz and the video bandwidth is 3MHz for RMS Average (Duty cycle < 98%) for Average detection (AV) at frequency above 1GHz, then the measurement results was added to a correction factor ($10 \log(1/\text{duty cycle})$).

7.3. TEST SETUP

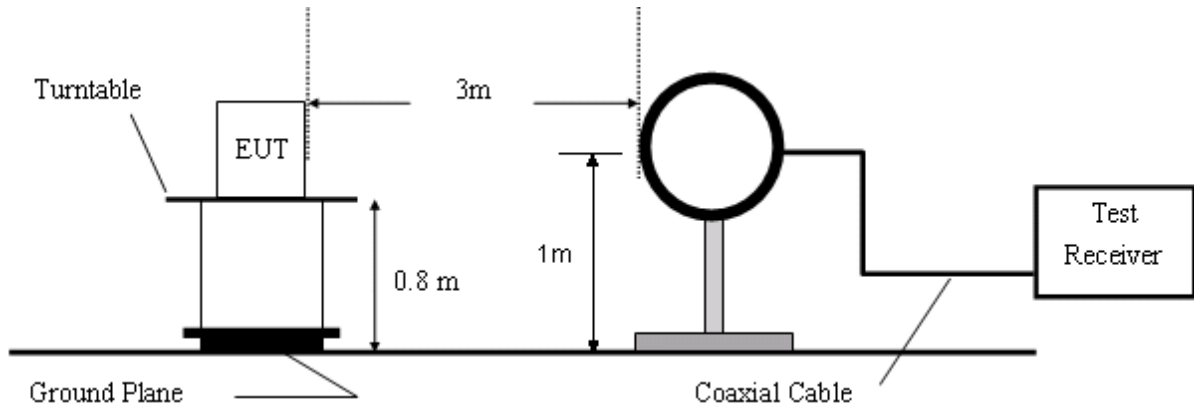

Figure 1. 9KHz to 30MHz radiated emissions test configuration

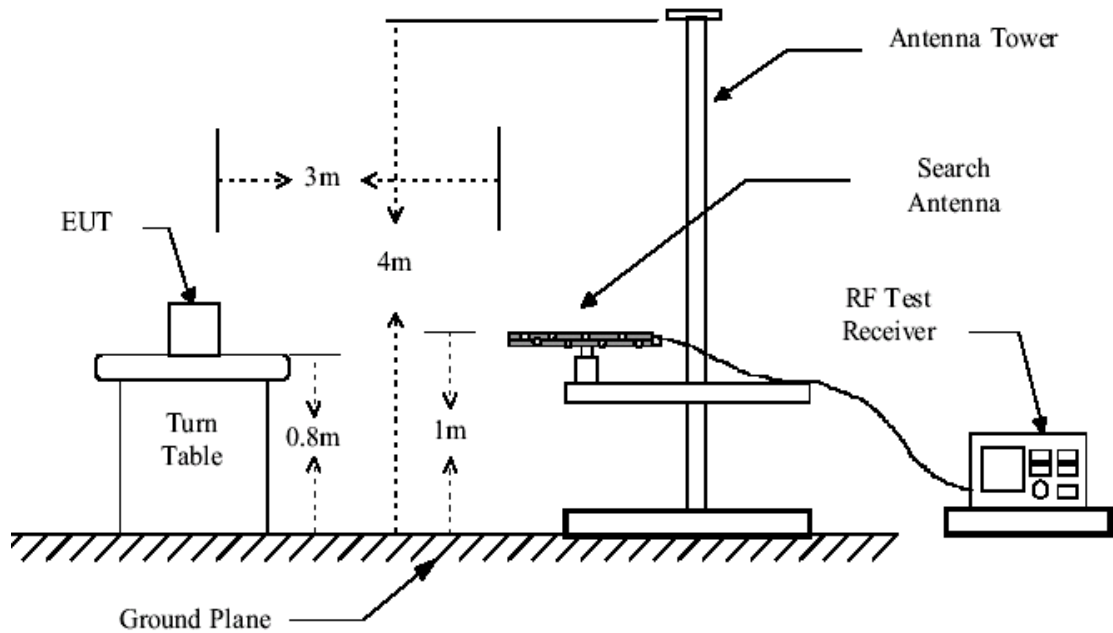

Figure 2. 30MHz to 1GHz radiated emissions test configuration

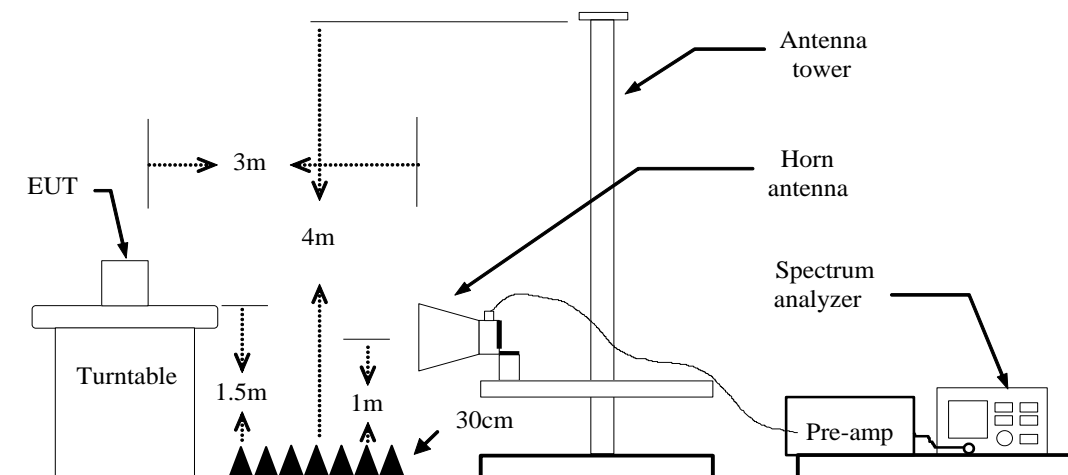

Figure 3. Above 1GHz radiated emissions test configuration

7.4. DATA SAMPLE

30MHz to 1GHz

No.	Frequency	Reading	Correct	Result	Limit	Margin	Remark	Pole
	(MHz)	(dBuV/m)	Factor(dB/m)	(dBuV/m)	(dBuV/m)	(dB)		
xxx	xxx	37.06	-15.48	21.58	40.00	-18.42	QP	Vertical

Above 1 GHz

No.	Frequency	Reading	Correct	Result	Limit	Margin	Remark	Pole
	(MHz)	(dBuV/m)	Factor(dB/m)	(dBuV/m)	(dBuV/m)	(dB)		
xxx	xxx	65.45	-11.12	54.33	74.00	-19.67	peak	Vertical
xxx	xxx	63.00	-11.12	51.88	54.00	-2.12	AVG	Vertical

Frequency (MHz)	= Emission frequency in MHz
Ant.Pol. (H/V)	= Antenna polarization
Reading (dBuV)	= Uncorrected Analyzer / Receiver reading
Correction Factor (dB/m)	= Antenna factor + Cable loss – Amplifier gain
Result (dBuV/m)	= Reading (dBuV) + Correction Factor (dB/m)
Limit (dBuV/m)	= Limit stated in standard
Margin (dB)	= Remark Result (dBuV/m) – Limit (dBuV/m)
Peak	= Peak Reading
QP	= Quasi-peak Reading
AVG	= Average Reading

7.5. TEST RESULTS

30MHz to 1GHz:

Pre-scan all modes and recorded the worst case results in this report (BT LE (Low Channel))

Mode: TX

Lowest channel (2402MHz)

Date: 2019-04-02

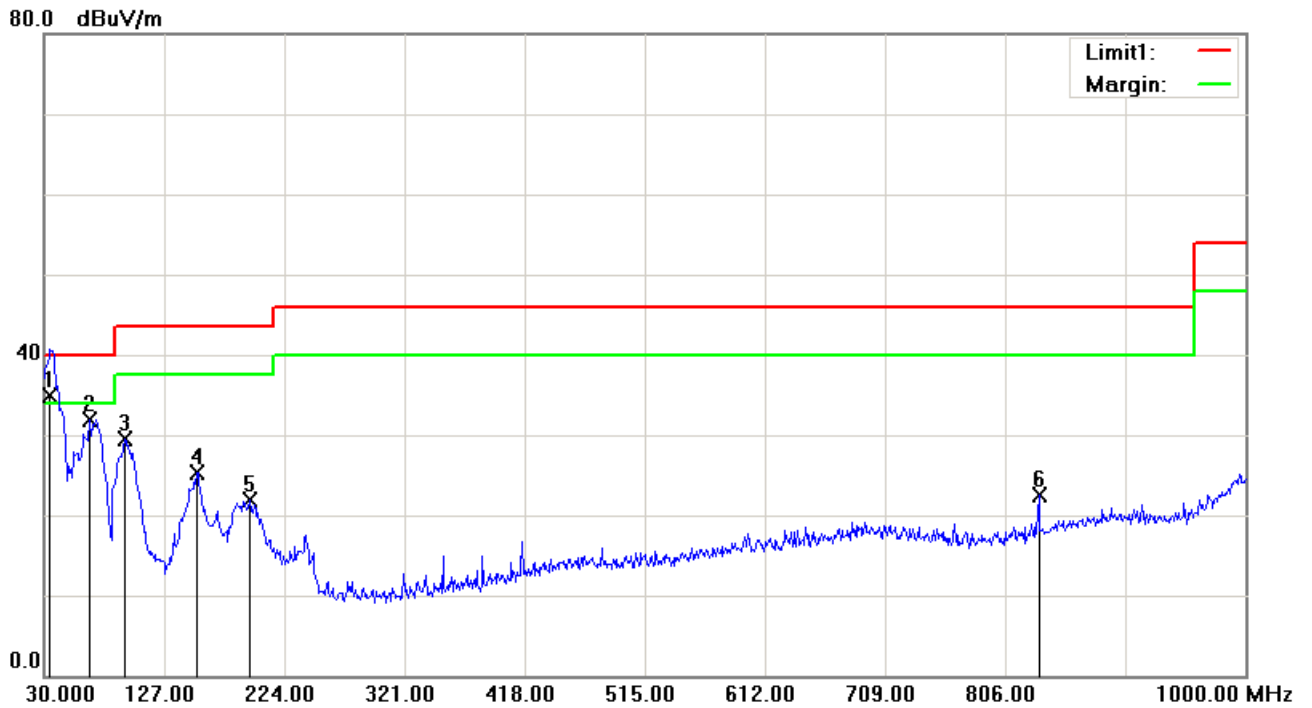

No.	Frequency (MHz)	Reading (dBuV/m)	Correct Factor(dB/m)	Result (dBuV/m)	Limit (dBuV/m)	Margin (dB)	Remark	Pole
1	34.8500	52.76	-17.76	35.00	40.00	-5.00	QP	Vertical
2	66.8600	50.64	-18.68	31.96	40.00	-8.04	QP	Vertical
3	94.9900	48.65	-19.11	29.54	43.50	-13.96	QP	Vertical
4	153.1900	40.73	-15.34	25.39	43.50	-18.11	QP	Vertical
5	195.8700	39.87	-18.02	21.85	43.50	-21.65	QP	Vertical
6	833.1600	28.43	-5.92	22.51	46.00	-23.49	QP	Vertical

Mode: TX

Lowest channel (2402MHz)

Date: 2019-04-02

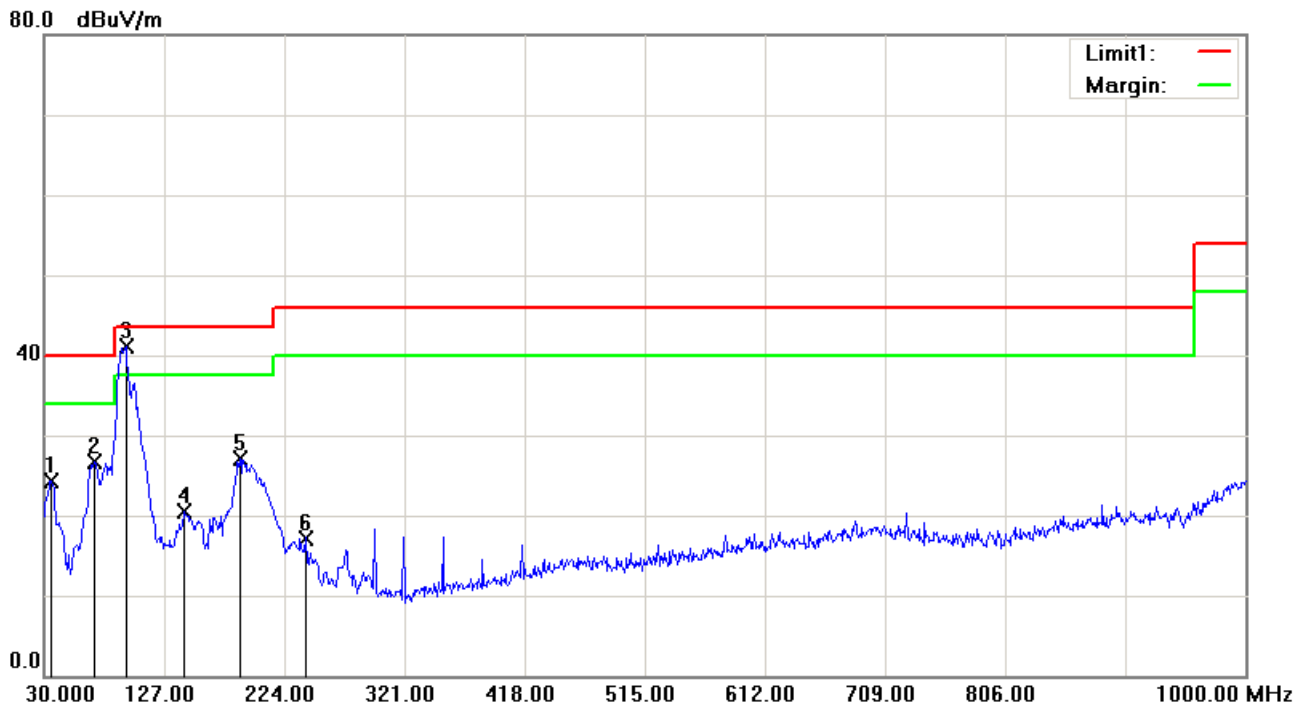

No.	Frequency (MHz)	Reading (dBuV/m)	Correct Factor(dB/m)	Result (dBuV/m)	Limit (dBuV/m)	Margin (dB)	Remark	Pole
1	35.8200	42.05	-17.72	24.33	40.00	-15.67	QP	Horizontal
2	70.7400	45.77	-19.14	26.63	40.00	-13.37	QP	Horizontal
3	95.9600	60.19	-19.00	41.19	43.50	-2.31	QP	Horizontal
4	143.4900	36.23	-15.77	20.46	43.50	-23.04	QP	Horizontal
5	188.1100	44.99	-17.81	27.18	43.50	-16.32	QP	Horizontal
6	241.4600	34.31	-17.11	17.20	46.00	-28.80	QP	Horizontal

Remark:

- 1 No emission found between lowest internal used/generated frequency to 30MHz.
- 2 Radiated emissions measured in frequency range from 9 kHz to 1GHz were made with an instrument using Quasi-peak detector mode.
- 3 Data of measurement within this frequency range shown “---” in the table above means the reading of emissions are attenuated more than 20dB below the permissible limits or the field strength is too small to be measured.
- 4 The IF bandwidth of Receiver between 30MHz to 1GHz was 120 kHz.

Above 1GHz:

Mode: TX

Lowest channel (2402MHz)

Date: 2019-04-10

No.	Frequency	Reading	Correct	Result	Limit	Margin	Remark	Pole
	(MHz)	(dBuV/m)	Factor(dB/m)	(dBuV/m)	(dBuV/m)	(dB)		
1	1900.000	53.39	-2.95	50.44	74.00	-23.56	peak	Vertical
2	2071.000	48.63	-2.19	46.44	74.00	-27.56	peak	Vertical
3	4807.000	42.83	2.35	45.18	74.00	-28.82	peak	Vertical
4	5761.000	43.70	4.50	48.20	74.00	-25.80	peak	Vertical
5	6013.000	41.77	5.28	47.05	74.00	-26.95	peak	Vertical
6	8155.000	41.86	9.11	50.97	74.00	-23.03	peak	Vertical
7	1810.000	47.02	-3.49	43.53	74.00	-30.47	peak	Horizontal
8	5077.000	42.00	2.45	44.45	74.00	-29.55	peak	Horizontal
9	5959.000	41.67	5.13	46.80	74.00	-27.20	peak	Horizontal
10	6364.000	42.05	5.80	47.85	74.00	-26.15	peak	Horizontal
11	7858.000	41.20	8.92	50.12	74.00	-23.88	peak	Horizontal
12	8182.000	41.66	9.08	50.74	74.00	-23.26	peak	Horizontal

Mode: TX

Middle channel (2440 MHz)

Date: 2019-04-10

No.	Frequency	Reading	Correct	Result	Limit	Margin	Remark	Pole
	(MHz)	(dBuV/m)	Factor(dB/m)	(dBuV/m)	(dBuV/m)	(dB)		
1	1900.000	50.40	-2.95	47.45	74.00	-26.55	peak	Vertical
2	3448.000	43.71	0.92	44.63	74.00	-29.37	peak	Vertical
3	5761.000	43.22	4.50	47.72	74.00	-26.28	peak	Vertical
4	6022.000	42.38	5.30	47.68	74.00	-26.32	peak	Vertical
5	8038.000	41.13	9.17	50.30	74.00	-23.70	peak	Vertical
6	8974.000	41.37	9.29	50.66	74.00	-23.34	peak	Vertical
7	1315.000	49.61	-5.83	43.78	74.00	-30.22	peak	Horizontal
8	4015.000	43.02	1.61	44.63	74.00	-29.37	peak	Horizontal
9	5572.000	41.43	3.90	45.33	74.00	-28.67	peak	Horizontal
10	7057.000	41.24	7.20	48.44	74.00	-25.56	peak	Horizontal
11	8929.000	42.13	9.25	51.38	74.00	-22.62	peak	Horizontal
12	9793.000	41.16	10.73	51.89	74.00	-22.11	peak	Horizontal

Mode: TX

Highest channel (2480MHz)

Date: 2019-04-10

No.	Frequency	Reading	Correct	Result	Limit	Margin	Remark	Pole
	(MHz)	(dBuV/m)	Factor(dB/m)	(dBuV/m)	(dBuV/m)	(dB)		
1	1900.000	50.93	-2.95	47.98	74.00	-26.02	peak	Vertical
2	2071.000	47.37	-2.19	45.18	74.00	-28.82	peak	Vertical
3	2512.000	46.02	-1.19	44.83	74.00	-29.17	peak	Vertical
4	5761.000	43.87	4.50	48.37	74.00	-25.63	peak	Vertical
5	6013.000	42.58	5.28	47.86	74.00	-26.14	peak	Vertical
6	8650.000	42.07	9.02	51.09	74.00	-22.91	peak	Vertical
7	1315.000	48.21	-5.83	42.38	74.00	-31.62	peak	Horizontal
8	2557.000	45.41	-0.99	44.42	74.00	-29.58	peak	Horizontal
9	4582.000	42.68	2.49	45.17	74.00	-28.83	peak	Horizontal
10	5761.000	41.38	4.50	45.88	74.00	-28.12	peak	Horizontal
11	6814.000	41.39	6.67	48.06	74.00	-25.94	peak	Horizontal
12	7597.000	40.61	8.45	49.06	74.00	-24.94	peak	Horizontal

Remark:

- 1 Measuring frequencies from 1 GHz to the 10th harmonic of highest fundamental frequency.
- 2 Radiated emissions measured in frequency above 1000MHz were made with an instrument using peak/average detector mode.
- 3 Average test would be performed if the peak result were greater than the average limit or as required by the applicant.
- 4 Data of measurement within this frequency range shown " --- " in the table above means the reading of emissions are attenuated more than 20dB below the permissible limits or the field strength is too small to be measured.
- 5 Measurements above show only up to 6 maximum emissions noted, or would be lesser, with " N/A " remark, if no specific emissions from the EUT are recorded (ie: margin>20dB from the applicable limit) and considered that's already beyond the background noise floor.

8. 6DB BANDWIDTH

8.1. LIMITS

Systems using digital modulation techniques may operate in the 902–928 MHz, 2400–2483.5 MHz, and 5725–5850 MHz bands. The minimum 6 dB bandwidth shall be at least 500 kHz.

8.2. TEST PROCEDURES

- 1) Remove the antenna from the EUT, and then connect a low loss RF cable from antenna port to the spectrum analyzer.
- 2) Set resolution bandwidth (RBW) = 100kHz. Set the video bandwidth (VBW) $\geq 3 \times$ RBW. Detector = Peak. Trace mode = max hold. Sweep = auto couple. Allow the trace to stabilize, record 6dB bandwidth value.
- 3) Repeat above procedures until all frequencies measured were complete.

8.3. TEST SETUP

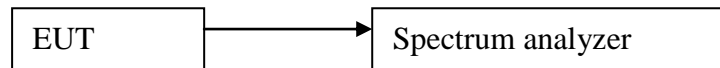

8.4. TEST RESULTS

Channel	Frequency (MHz)	Bandwidth (kHz)	Limit (kHz)	Test Result
Lowest	2402	690.7	>500	PASS
Middle	2440	687.7		PASS
Highest	2480	679.0		PASS

Lowest channel (2402MHz)

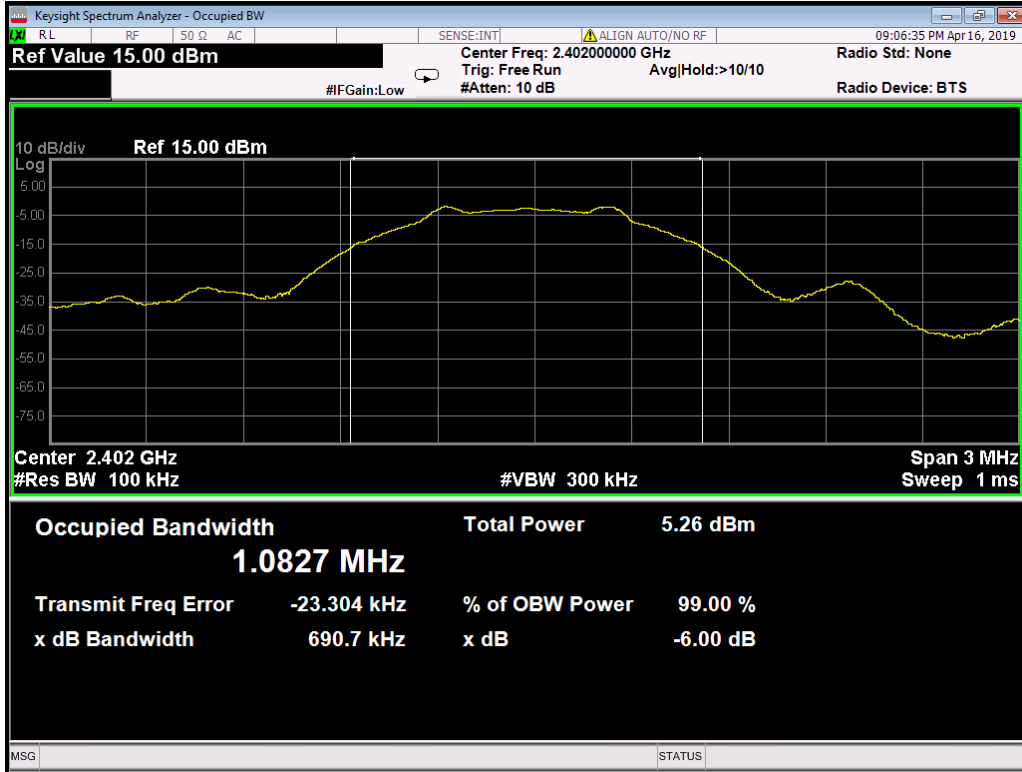

Middle channel (2440 MHz)

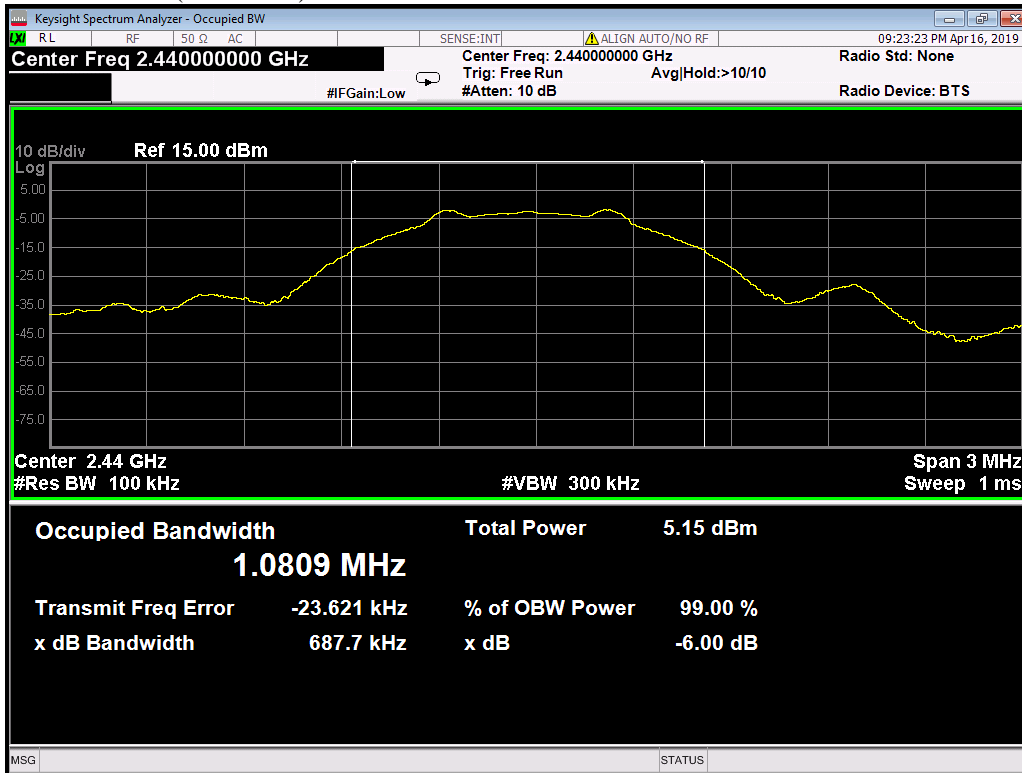

Highest channel (2480MHz)

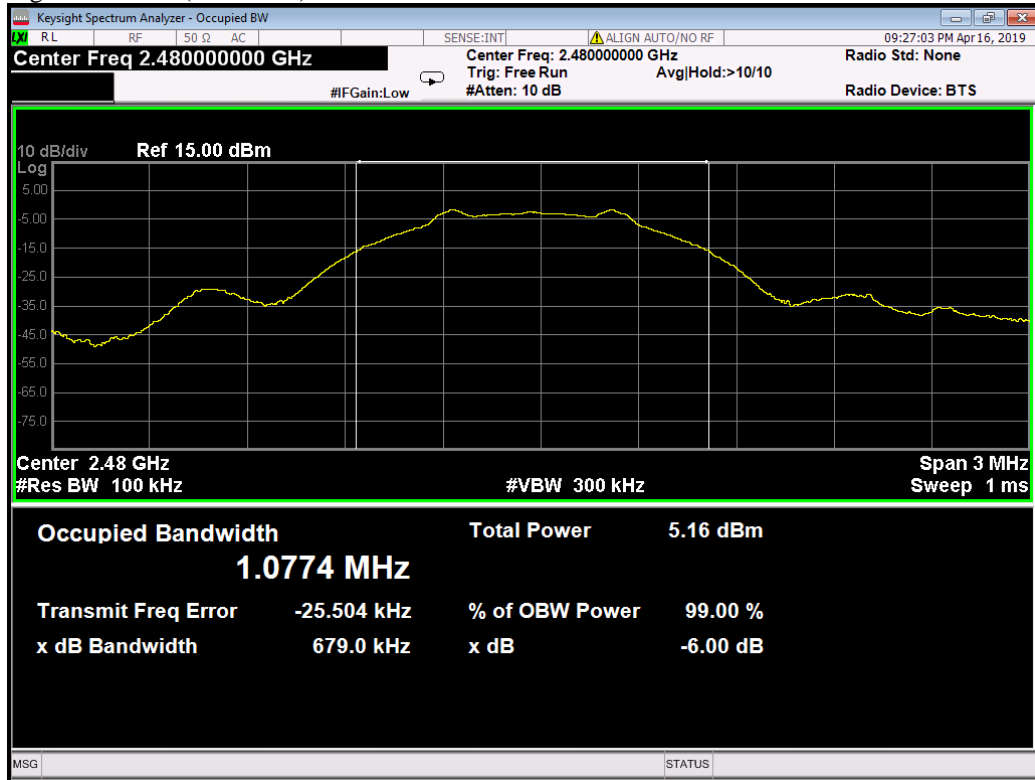

9. MAXIMUM PEAK OUTPUT POWER

9.1 LIMITS

The maximum Peak output power measurement is 1W

9.2 TEST PROCEDURES

- 1) Place the EUT on a bench and set it in transmitting mode.
- 2) Remove the antenna from the EUT and then connect a low loss RF cable from the antenna port to an EMI Test Receiver.
- 3) The spectrum analyzer resolution bandwidth that is \leq EBW. So we test the Maximum Conducted Output Power —Integrated band power method.
- 4) Set the analyzer span $\geq 1.5 \times$ DTS bandwidth. Set the RBW = 1 MHz. Set the VBW ≥ 3 MHz. Sweep time = auto couple. Detector = peak. Allow trace to fully stabilize.

9.3 TEST SETUP

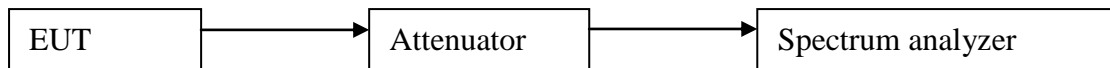

9.4 TEST RESULTS

Channel	Frequency (MHz)	Measured Channel Power (dBm)	Limit	Peak/ Average	Result
Lowest	2402	-1.58	1W (30dBm)	Peak	Pass
Middle	2440	-1.67			Pass
Highest	2480	-1.61			Pass
Lowest	2402	-1.64		Average	Pass
Middle	2440	-1.71			Pass
Highest	2480	-1.62			Pass

10. POWER SPECTRAL DENSITY

10.1 LIMITS

For digitally modulated systems, the power spectral density conducted from the intentional radiator to the antenna shall not be greater than 8 dBm in any 3 kHz band during any time interval of continuous transmission. This power spectral density shall be determined in accordance with the provisions of paragraph (b) of this section. The same method of determining the conducted output power shall be used to determine the power spectral density.

10.2 TEST PROCEDURES

- 1) Remove the antenna from the EUT, and then connect a low loss RF cable from antenna port to the spectrum analyzer.
- 2) Position the EUT was set without connection to measurement instrument. Turn on the EUT and connect its antenna terminal to measurement instrument via a low loss cable. Then set it to any one measured frequency within its operating range, and make sure the instrument is operated in its linear range.
- 3) Set the analyzer span to 1.5 times the DTS bandwidth. Set the RBW = 3 kHz. Set the VBW ≥ 3 RBW. Detector = peak. Ensure that the number of measurement points in the sweep $\geq 2 \times$ span/RBW (use of a greater number of measurement points than this minimum requirement is recommended).
- 4) Repeat above procedures until all frequencies measured were complete.

10.3 TEST SETUP

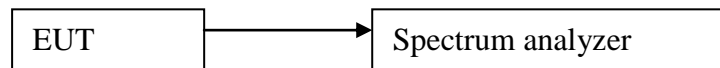

10.4 TEST RESULTS

Channel	Frequency (MHz)	PPSD (dBm)	Limit (dBm)	Test Result
Lowest	2402	-13.425	8	PASS
Middle	2440	-13.186		PASS
Highest	2480	-13.213		PASS

Lowest channel (2402MHz)

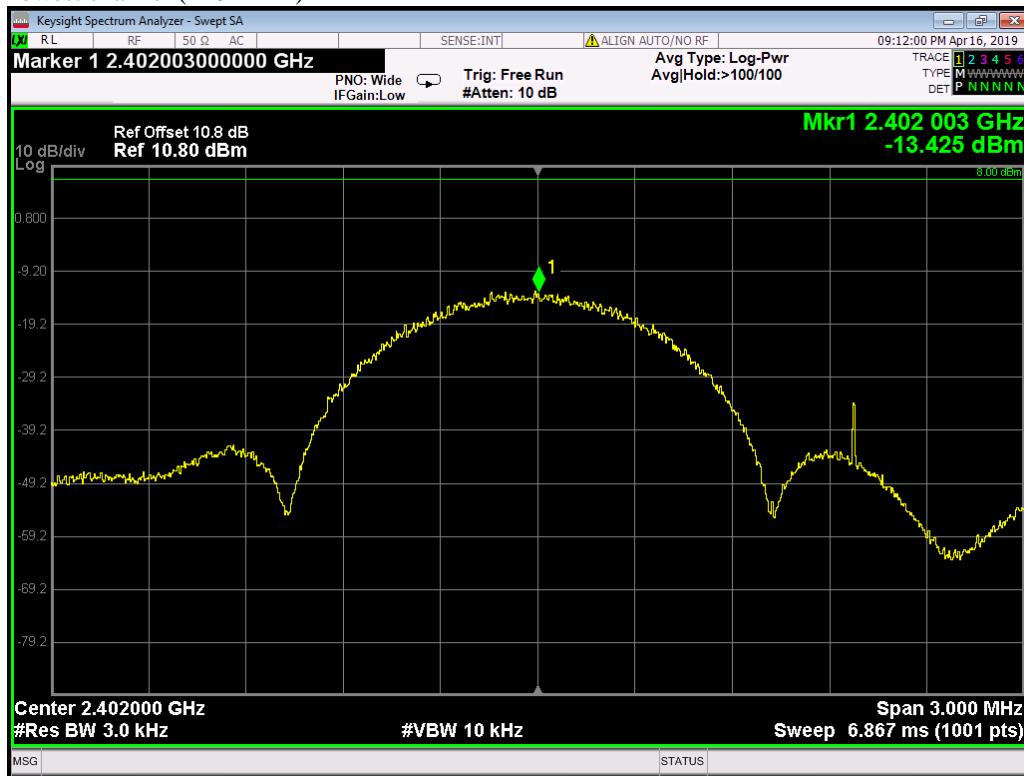

Middle channel (2440 MHz)

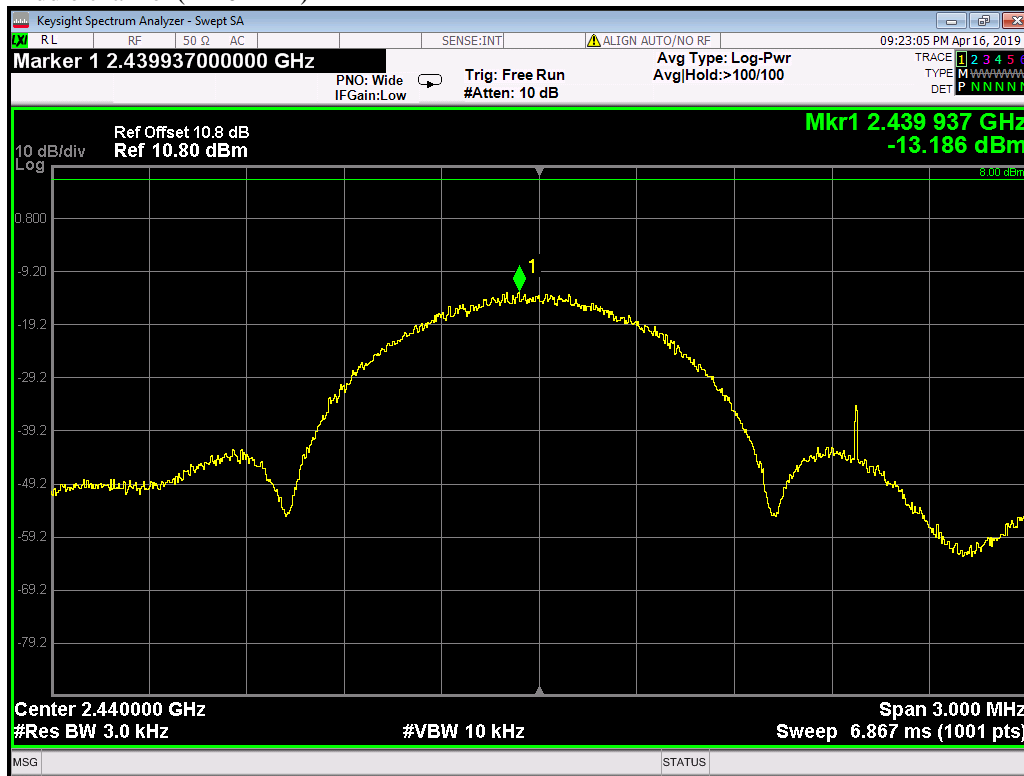

Highest channel (2480MHz)

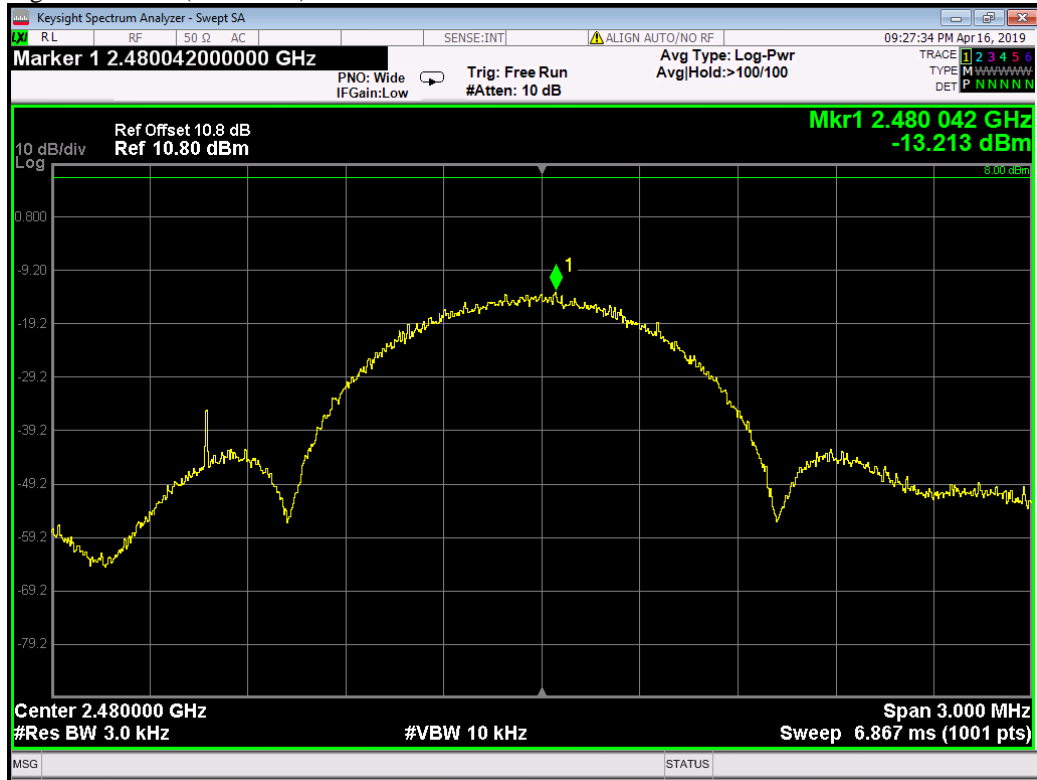

11. CONDUCTED BAND EDGES AND SPURIOUS EMISSIONS

11.2. LIMITS

(d) In any 100 kHz bandwidth outside the frequency band in which the spread spectrum or digitally modulated intentional radiator is operating, the radio frequency power that is produced by the intentional radiator shall be at least 20 dB below that in the 100 kHz bandwidth within the band that contains the highest level of the desired power, based on either an RF conducted or a radiated measurement, provided the transmitter demonstrates compliance with the peak conducted power limits. If the transmitter complies with the conducted power limits based on the use of RMS averaging over a time interval, as permitted under paragraph (b)(3) of this section, the attenuation required under this paragraph shall be 30 dB instead of 20 dB.

11.3. TEST PROCEDURES

Test procedures follow KDB 558074 D01 DTS Measurement Guidance v03r01.

Remove the antenna from the EUT and then connect a low attenuation cable from the antenna port to the spectrum.

- 1) Remove the antenna from the EUT and then connect a low attenuation cable from the antenna port to the spectrum.
- 2) Set the spectrum analyzer: RBW =100KHz; VBW =300KHz, Span = 10MHz to 26GHz; Sweep = auto; Detector Function = Peak. Trace = Max, hold.
- 3) Measure and record the results in the test report.
- 4) The RF fundamental frequency should be excluded against the limit line in the operating frequency band.

11.4. TEST SETUP

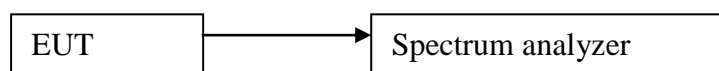

11.5. TEST RESULTS

Lowest channel (2402MHz)
0.01GHz-26.5GHz

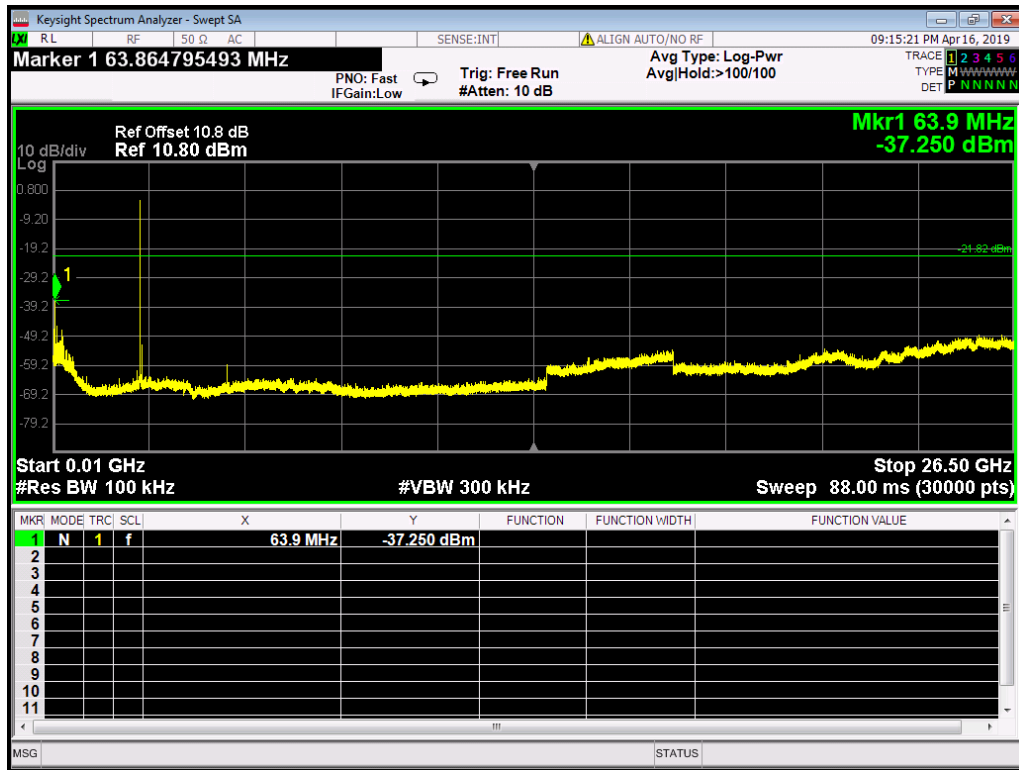

2.31GHz-2.41GHz

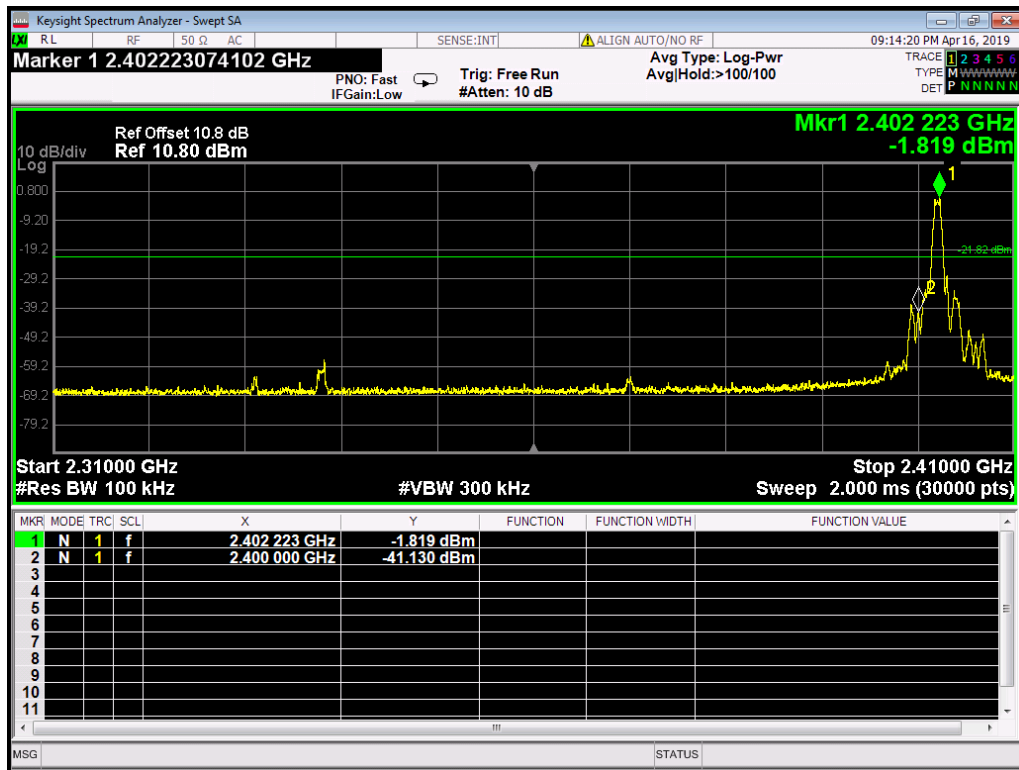

Middle channel (2440 MHz)
0.01GHz-26.5GHz

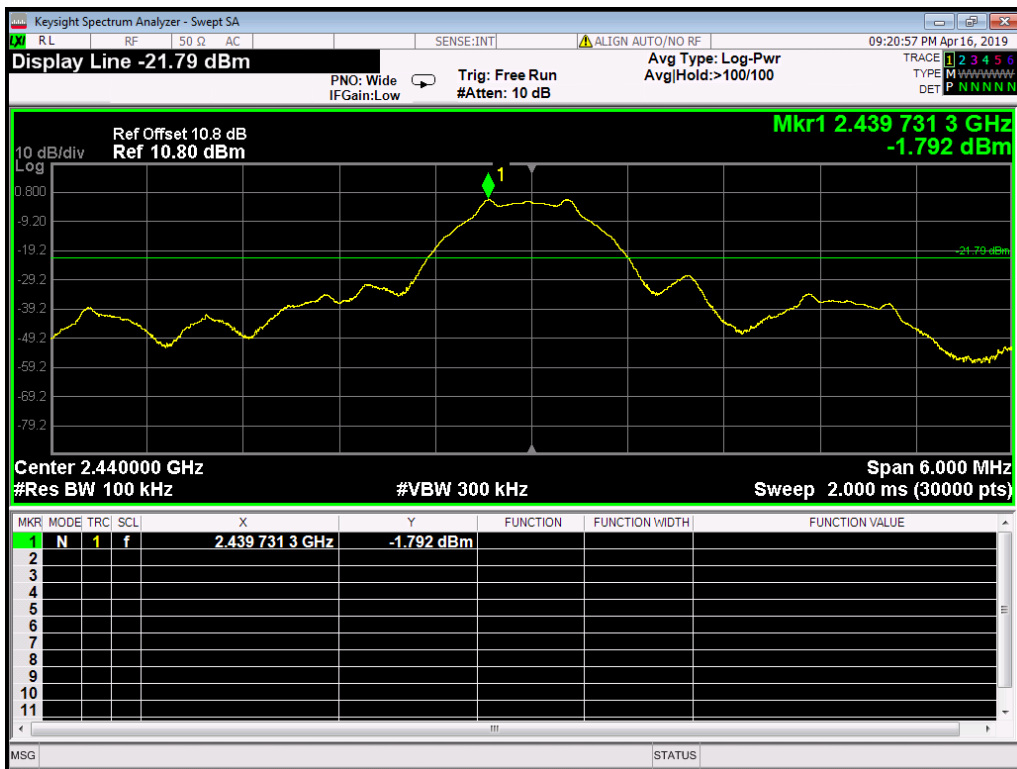
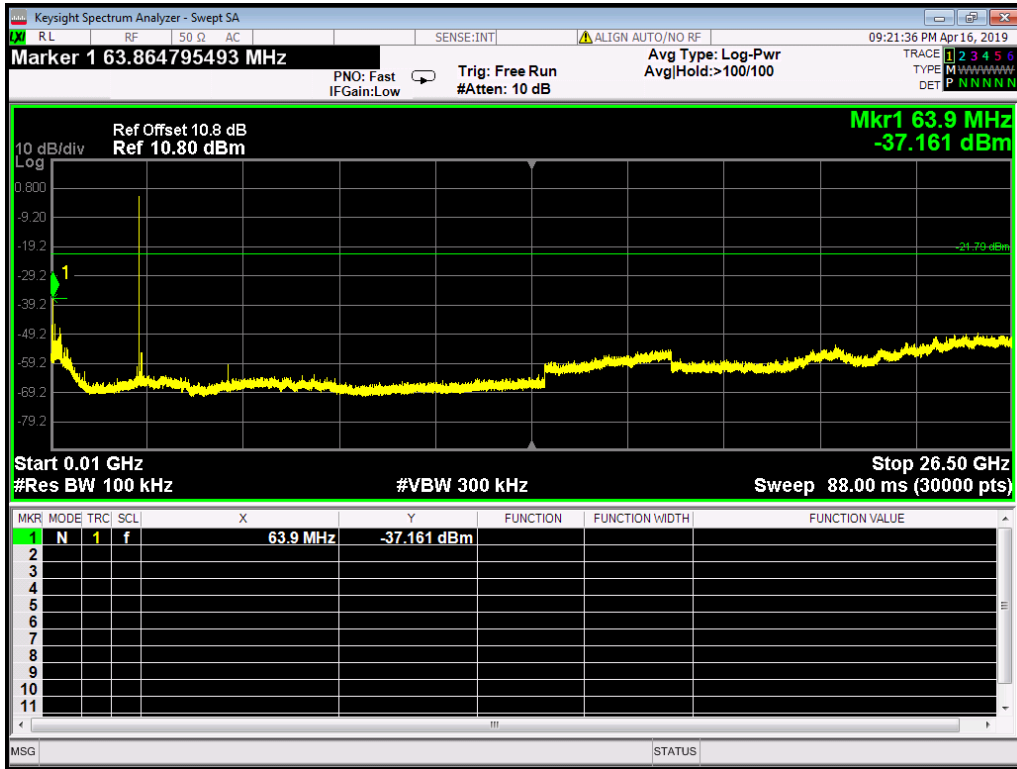

Highest channel (2480MHz)
0.01GHz-26.5GHz

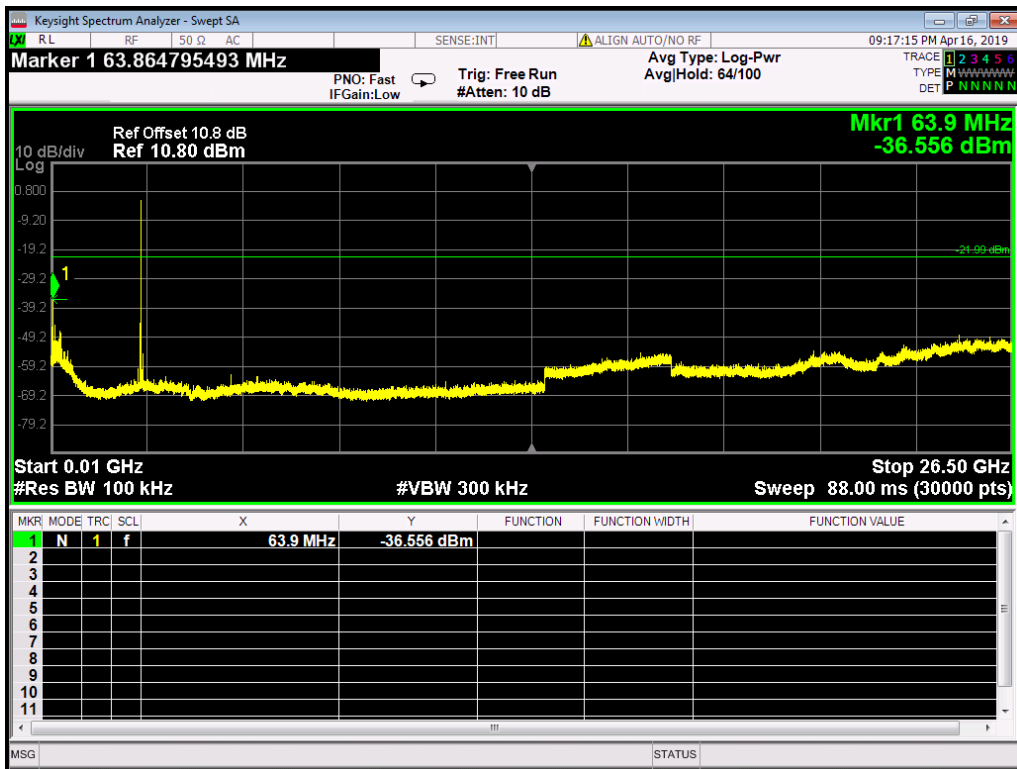

2.475GHz-2.5GHz

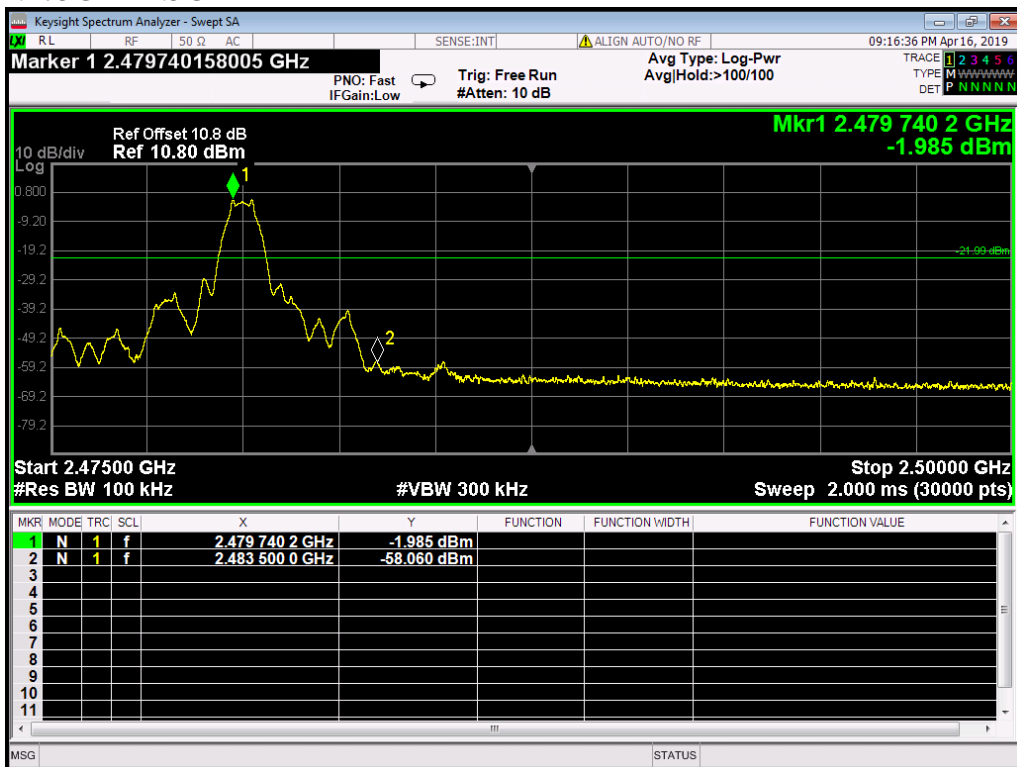

12. RESTRICTED BANDS OF OPERATION

12.1.LIMITS

Section 15.247(d) In addition, Radiated emissions which fall in the restricted bands, as defined in §15.205(a), must also comply with the radiated emission limits specified in §15.209(a) (see §15.205(c)).

MHz	MHz	MHz	GHz
0.090 - 0.110	16.42 - 16.423	399.9 - 410	4.5 - 5.15
¹ 0.495 - 0.505	16.69475 -	608 - 614	5.35 - 5.46
2.1735 - 2.1905	16.69525	960 - 1240	7.25 - 7.75
4.125 - 4.128	16.80425 -	1300 - 1427	8.025 - 8.5
4.17725 - 4.17775	16.80475	1435 - 1626.5	9.0 - 9.2
4.20725 - 4.20775	25.5 - 25.67	1645.5 - 1646.5	9.3 - 9.5
6.215 - 6.218	37.5 - 38.25	1660 - 1710	10.6 - 12.7
6.26775 - 6.26825	73 - 74.6	1718.8 - 1722.2	13.25 - 13.4
6.31175 - 6.31225	74.8 - 75.2	2200 - 2300	14.47 - 14.5
8.291 - 8.294	108 - 121.94	2310 - 2390	15.35 - 16.2
8.362 - 8.366	123 - 138	2483.5 - 2500	17.7 - 21.4
8.37625 - 8.38675	149.9 - 150.05	2655 - 2900	22.01 - 23.12
8.41425 - 8.41475	156.52475 -	3260 - 3267	23.6 - 24.0
12.29 - 12.293	156.52525	3332 - 3339	31.2 - 31.8
12.51975 -	156.7 - 156.9	3345.8 - 3358	36.43 - 36.5
12.52025	162.0125 - 167.17	3600 - 4400	
12.57675 -	167.72 - 173.2		
12.57725	240 - 285		
13.36 - 13.41	322 - 335.4		

12.2.TEST PROCEDURES

Test procedures follow KDB 558074 D01 DTS Meas Guidance v03r01.

- 1) The EUT is placed on a turntable, which is 1.5m above the ground plane.
- 2) The turntable shall be rotated for 360 degrees to determine the position of maximum emission level.
- 3) EUT is set 3m away from the receiving antenna, which is varied from 1m to 4m to find out the highest emission.
- 4) Set the spectrum analyzer in the following setting in order to capture the lower and upper band-edges of the emission:
 - a) PEAK: RBW=1MHz / VBW=1MHz / Sweep=AUTO
 - b) AVERAGE: RBW=1MHz / VBW=1/T / Sweep=AUTO
- 5) Repeat the procedures until all the PEAK and AVERAGE versus POLARIZATION are measured.

12.3.TEST SETUP

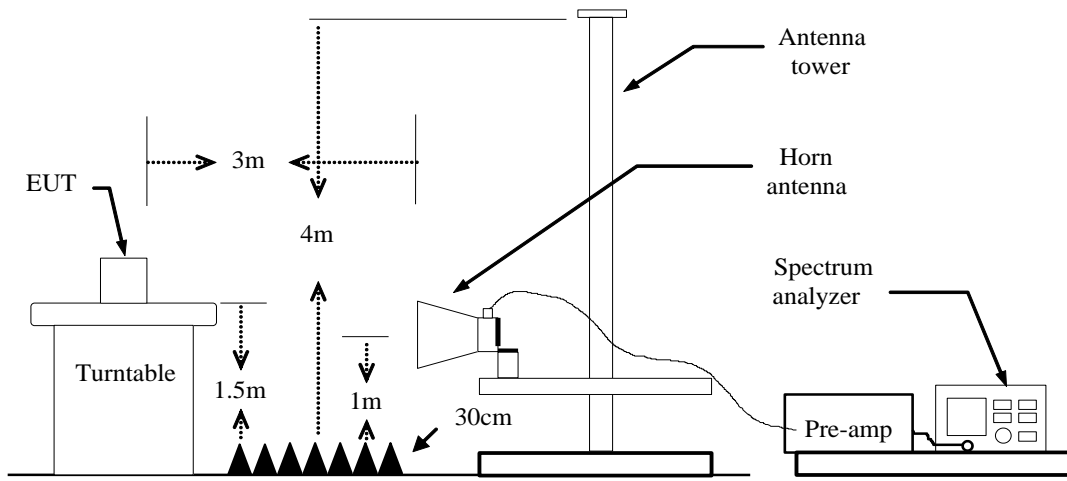

12.4.TEST RESULTS

Lowest Channel

Detector mode: Peak

Polarity: Vertical

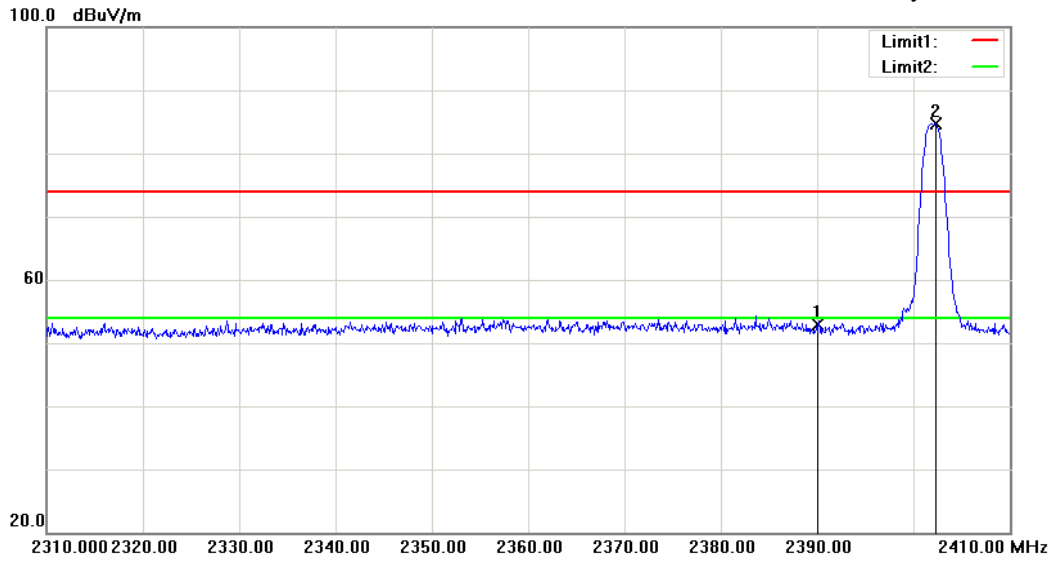

Detector mode: Average

Polarity: Vertical

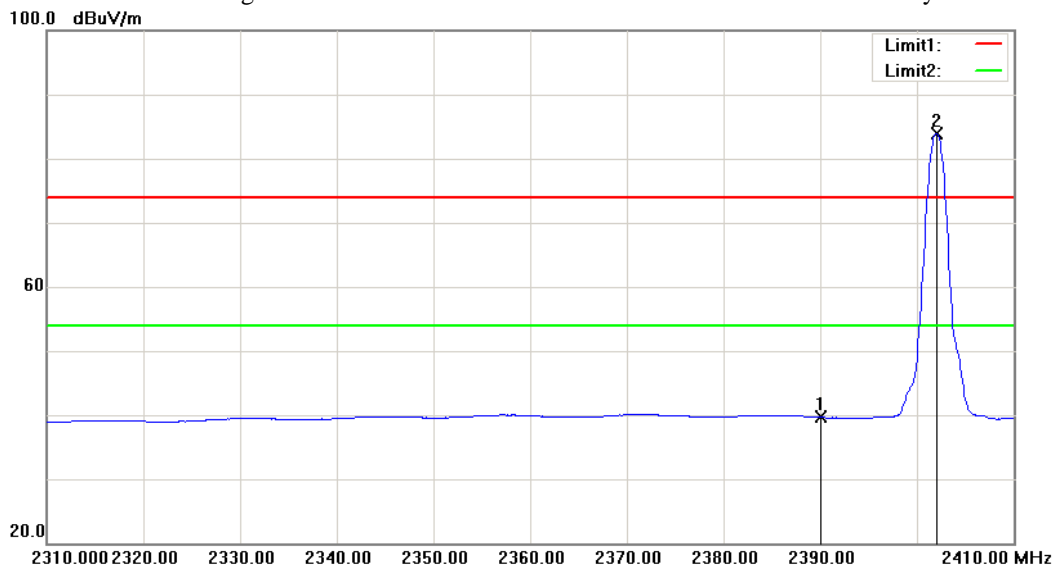

No.	Frequency MHz	Reading dBuV	Factor dB	Result dBuV/m	Limit dBuV/m	Margin dB	Remark	Pole
1	2390.000	54.45	-1.48	52.97	74.00	-21.03	Peak	Vertical
2	2402.300	86.08	-1.45	---	74.00	---	Peak	Vertical
1	2390.000	41.13	-1.48	39.65	54.00	-14.35	Average	Vertical
2	2402.000	85.41	-1.46	---	54.00	---	Average	Vertical

Lowest Channel

Detector mode: Peak

Polarity: Horizontal

100.0 dBuV/m

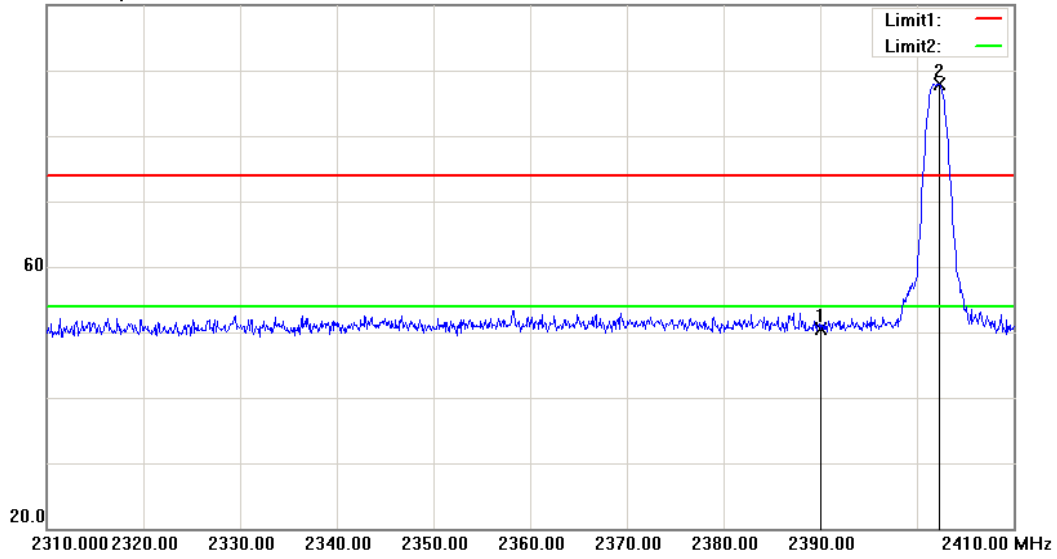

Detector mode: Average

Polarity: Horizontal

100.0 dBuV/m

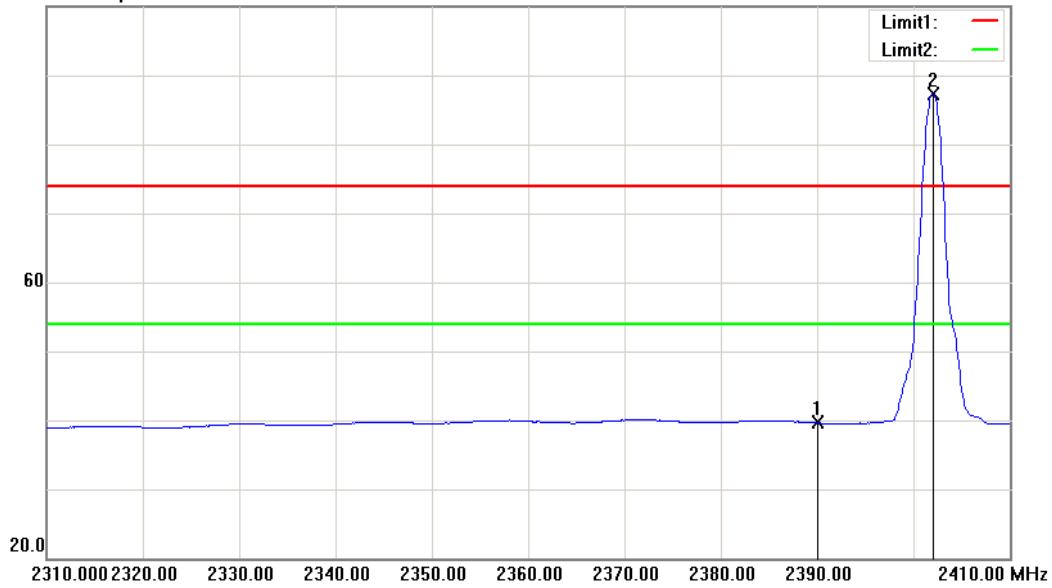

No.	Frequency MHz	Reading dBuV	Factor dB	Result dBuV/m	Limit dBuV/m	Margin dB	Remark	Pole
1	2390.000	51.89	-1.48	50.41	74.00	-23.59	Peak	Horizontal
2	2402.300	89.34	-1.45	---	74.00	---	Peak	Horizontal
1	2390.000	41.12	-1.48	39.64	54.00	-14.36	Average	Horizontal
2	2402.000	88.73	-1.46	---	54.00	---	Average	Horizontal

Highest channel

Detector mode: Peak

Polarity: Vertical

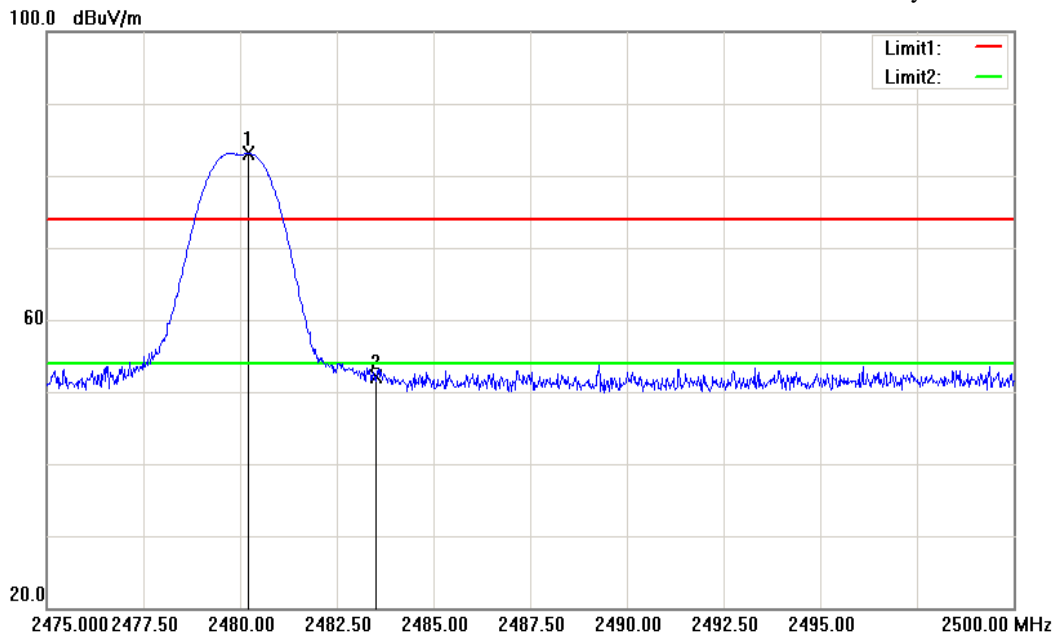

Detector mode: Average

Polarity: Vertical

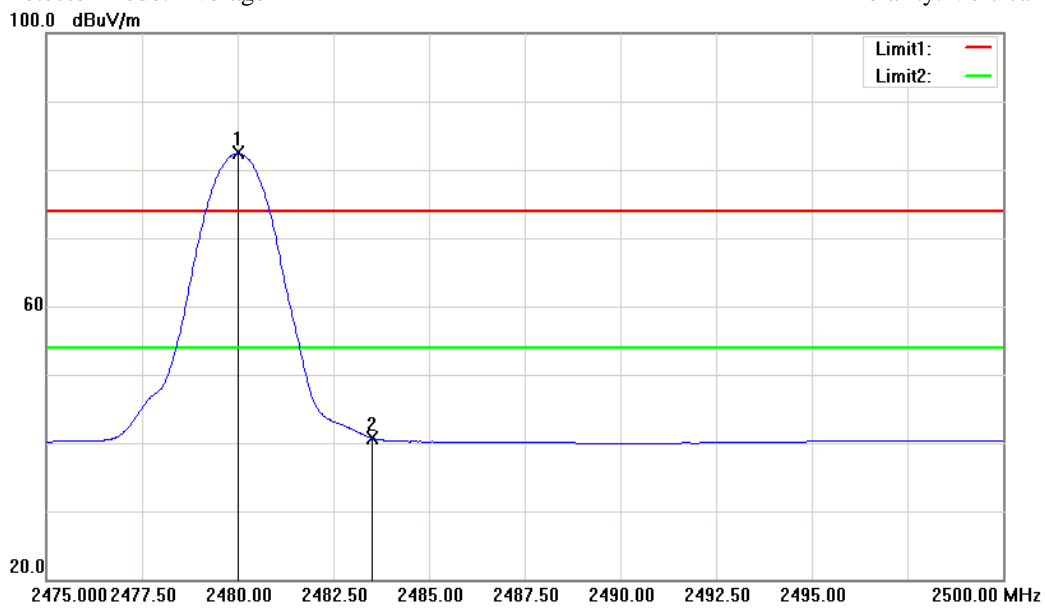

No.	Frequency MHz	Reading dBuV	Factor dB	Result dBuV/m	Limit dBuV/m	Margin dB	Remark	Pole
1	2480.225	84.39	-1.28	---	74.00	---	Peak	Vertical
2	2483.500	53.31	-1.27	52.04	74.00	-21.96	Peak	Vertical
1	2480.000	83.69	-1.28	---	54.00	---	Average	Vertical
2	2483.500	42.00	-1.27	40.73	54.00	-13.27	Average	Vertical

Highest channel

Detector mode: Peak

Polarity: Horizontal

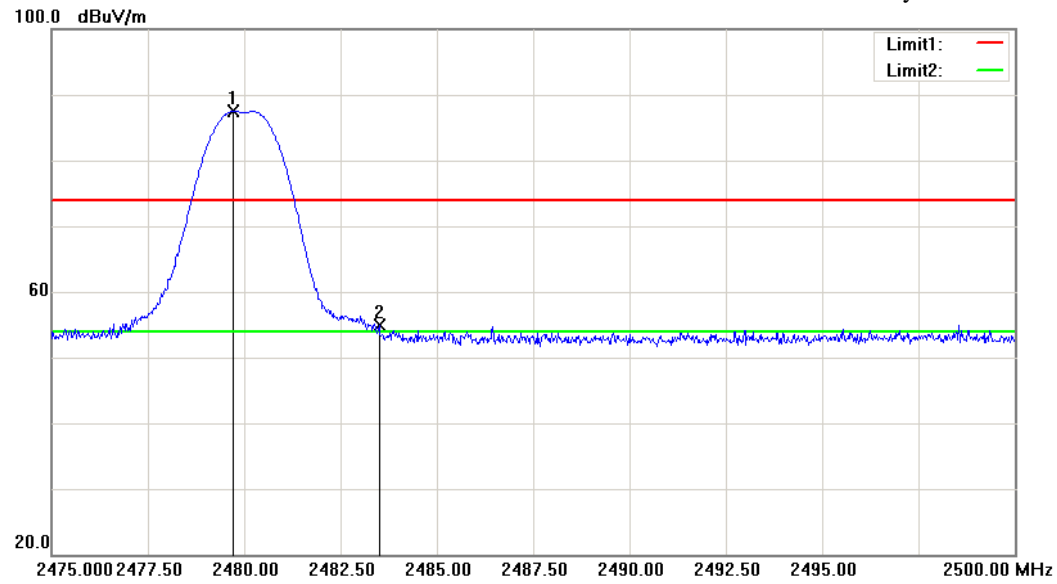

Detector mode: Average

Polarity: Horizontal

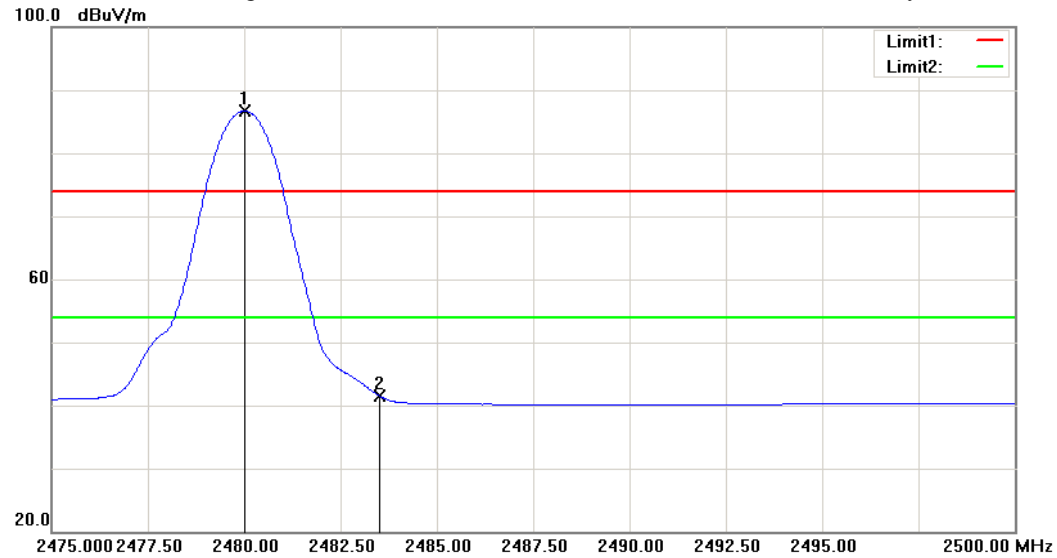

No.	Frequency MHz	Reading dBuV	Factor dB	Result dBuV/m	Limit dBuV/m	Margin dB	Remark	Pole
1	2479.700	88.77	-1.28	---	74.00	---	Peak	Horizontal
2	2483.500	56.11	-1.27	54.84	74.00	-19.16	Peak	Horizontal
1	2480.000	87.96	-1.28	---	54.00	---	Average	Horizontal
2	2483.500	42.79	-1.27	41.52	54.00	-12.48	Average	Horizontal

Remark: Max field strength in 3m distance. No any other emission which falls in restricted bands can be detected and be reported.

APPENDIX A: PHOTOGRAPH OF THE TEST ARRANGEMENT CE

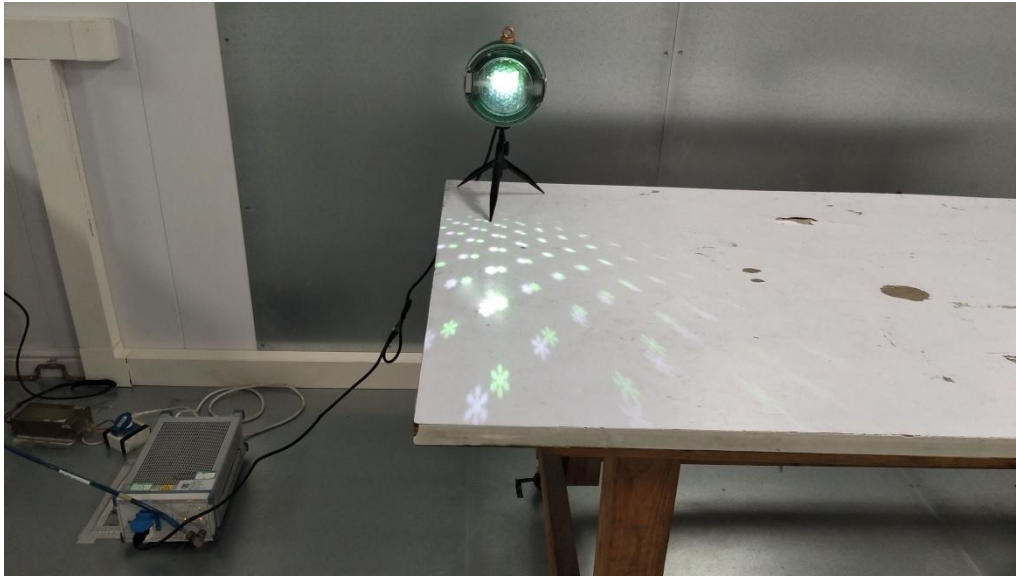

RSE (Below 1GHz)

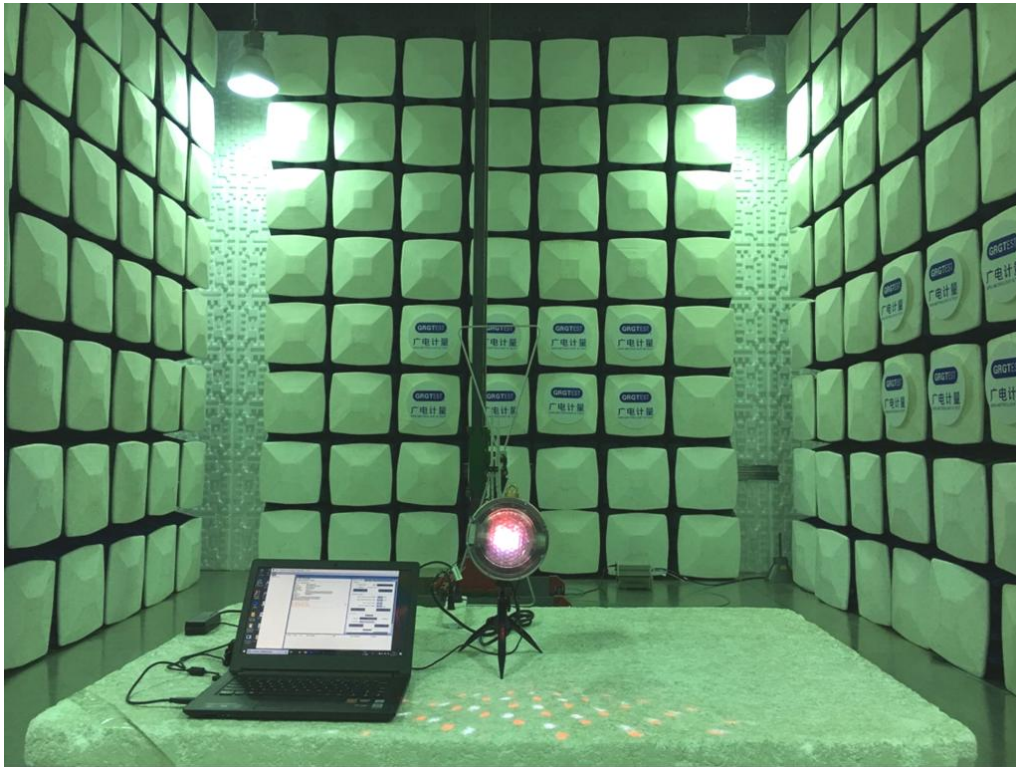

RSE (Above 1GHz)

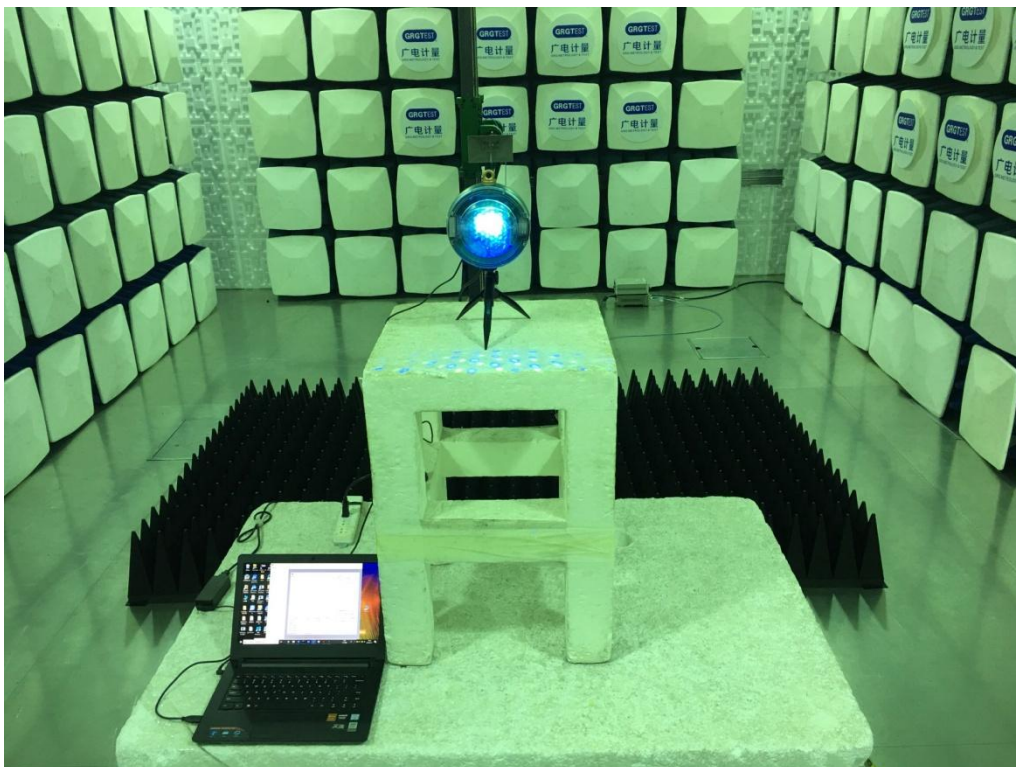

-----This is the last page of the report. -----