

ELECTROMAGNETIC EMISSIONS COMPLIANCE REPORT

INTENTIONAL RADIATOR CERTIFICATION TO FCC PART 15 SUBPART C REQUIREMENT

OF

Product name: Wireless Calculator Mobile Mini Keypad

Model Name: WKP-300

FCC ID: GM8WKP300

REPORT NO: ER/2004/20011

ISSUE DATE: Feb. 11, 2004

FCC Rule Part: §15.227

Prepared for Ortek Technology Inc.

13F, Number 150, Jian Yi Rd., Chung Ho
City, Taipei Hsien, Taiwan, R.O.C.

Prepared by SGS Taiwan Ltd.

No. 134, Wu Kung Rd., Wuku Industrial
Zone, Taipei County, Taiwan.

Note: This report shall not be reproduced except in full, without the written approval of SGS Taiwan Ltd. This document may be altered or revised by SGS Taiwan Ltd. personnel only, and shall be noted in the revision section of the document.

The results shown in this test report refer only to the sample(s) tested unless otherwise stated. This test report cannot be reproduced, except in full, without prior written permission of the Company.

SGS Taiwan Ltd.

No. 134, Wu Kung Rd., Wuku Industrial Zone, Taipei Country, Taiwan.

TEL: 886-2-22993939

FAX: 886-2-22982698

VERIFICATION OF COMPLIANCE

Applicant:	Ortek Technology Inc. 13F, Number 150, Jian Ti Rd., Chung Ho City, Taipei Hsien, Taiwan, R.O.C.
Product Description:	Wireless Calculator Mobile Mini Keypad
FCC ID Number:	GM8WKP300
Model No.:	WKP-300
Model Difference:	N/A
File Number:	ER/2004/20011
Date of test:	Feb. 8, 2004

We hereby certify that:

The above equipment was tested by SGS Taiwan Ltd. The test data, data evaluation, test procedures, and equipment configurations shown in this report were made in accordance with the procedures given in ANSI C63.4 (1992) and the energy emitted by the sample EUT tested as described in this report is in compliance with conducted and radiated emission limits of FCC Rules Part 15.227.

The test results of this report relate only to the tested sample identified in this report.

Test By:

Willis Chen

Date

Feb. 11, 2004

Willis Chen

Approved By

Vincent Su

Date

Feb. 11, 2004

Vincent Su

The results shown in this test report refer only to the sample(s) tested unless otherwise stated. This test report cannot be reproduced, except in full, without prior written permission of the Company.

SGS Taiwan Ltd.

No. 134, Wu Kung Rd., Wuku Industrial Zone, Taipei Country, Taiwan.

TEL: 886-2-22993939

FAX: 886-2-22982698

Table of Contents

1.	GENERAL INFORMATION	4
1.1	PRODUCT DESCRIPTION	4
1.2	RELATED SUBMITTAL(S) / GRANT (S).....	4
1.3	TEST METHODOLOGY.....	4
1.4	TEST FACILITY	4
2.	SYSTEM TEST CONFIGURATION	5
2.1	EUT CONFIGURATION.....	5
2.2	EUT EXERCISE.....	5
2.3	TEST PROCEDURE.....	5
2.4	LIMITATION.....	5
2.5	CONFIGURATION OF TESTED SYSTEM.....	7
3.	SUMMARY OF TEST RESULTS	8
4.	DESCRIPTION OF TEST MODES	8
5.	CONDUCTED EMISSIONS TEST (NOT APPLY IN THE REPORT)	9
5.1	MEASUREMENT PROCEDURE:	9
5.2	TEST SET-UP (BLOCK DIAGRAM OF CONFIGURATION).....	9
5.3	MEASUREMENT EQUIPMENT USED:	9
5.4	MEASUREMENT RESULT:	9
6.	RADIATED EMISSION TEST	10
6.1	MEASUREMENT PROCEDURE.....	14
6.2	TEST SET-UP (BLOCK DIAGRAM OF CONFIGURATION).....	14
6.3	MEASUREMENT EQUIPMENT USED:	15
6.4	FIELD STRENGTH CALCULATION	15
6.5	MEASUREMENT RESULT	16
6.6	MEASUREMENT RESULT	17
7.	OCCUPIED BANDWIDTH.....	18
7.1	MEASUREMENT PROCEDURE.....	18
7.2	TEST SET-UP (BLOCK DIAGRAM OF CONFIGURATION).....	18
7.3	MEASUREMENT EQUIPMENT USED:	18
7.4	MEASUREMENT RESULTS.....	18

The results shown in this test report refer only to the sample(s) tested unless otherwise stated. This test report cannot be reproduced, except in full, without prior written permission of the Company.

1. GENERAL INFORMATION

1.1 Product Description

The Ortek Technology Inc. Model: WKP-300 (referred to as the EUT in this report) The EUT is an short range, lower power, Wireless Calculator Mobile Mini Keypad designed as an " Input Device. It is designed by way of utilizing the FSK modulation achieves the system operating.

A major technical descriptions of EUT is described as following:

- A). Operation Frequency: 27.095MHz, one channel.
- B). Modulation : Frequency Shifting Key (FSK) Modulation
- C). Antenna Designation: Non-User Replaceable (Fixed)
- D). Power Supply: 1.5 Vdc by AAA *1 Battery.

1.2 Related Submittal(s) / Grant (s)

This submittal(s) (test report) is intended for FCC ID: **GM8WKP300** filing to comply with Section 15.227 of the FCC Part 15, Subpart C Rules. The composite system (receiver) is compliance with Subpart B is authorized under a DoC procedure.

1.3 Test Methodology

Both conducted and radiated testing were performed according to the procedures in ANSI C63.4 (1992). Radiated testing was performed at an antenna to EUT distance 3 meters.

1.4 Test Facility

The open area test site and conducted measurement facility used to collect the radiated data is located on the address of SGS Taiwan Ltd. No. 134, Wu Kung Rd., Wuku Industrial Zone, Taipei Country, Taiwan. The Open Area Test Sites and the Line Conducted labs are constructed and calibrated to meet the FCC requirements in documents ANSI C63.4: 1992 and CISPR 22/EN 55022 requirements. Site No. 1(3 &10 meters) Registration Number: 94644, Anechoic chamber (3 meters) Registration Number: 573967

1.5 Special Accessories

Not available for this EUT intended for grant.

1.6 Equipment Modifications

Not available for this EUT intended for grant.

The results shown in this test report refer only to the sample(s) tested unless otherwise stated. This test report cannot be reproduced, except in full, without prior written permission of the Company.

2. System Test Configuration

2.1 EUT Configuration

The EUT configuration for testing is installed on RF field strength measurement to meet the Commissions requirement and operating in a manner which intends to maximize its emission characteristics in a continuous normal application.

2.2 EUT Exercise

The Transmitter was operated in the normal operating mode. the Tx frequency was fixed which was for the purpose of the measurements.

2.3 Test Procedure

2.3.1 Conducted Emissions (Not apply in the report)

The EUT is a placed on as turn table which is 0.8 m above ground plane. According to the requirements in Section 13.1.4.1 of ANSI C63.4-1992. Conducted emissions from the EUT measured in the frequency range between 0.15 MHz and 30MHz using CISPR Quasi-Peak and average detector mode.

2.3.2 Radiated Emissions

The EUT is a placed on as turn table which is 0.8 m above ground plane. The turn table shall rotate 360 degrees to determine the position of maximum emission level. EUT is set 3m away from the receiving antenna which varied from 1m to 4m to find out the highest emission. And also, each emission was to be maximized by changing the polarization of receiving antenna both horizontal and vertical. In order to find out the max. emission, the relative positions of this hand-held transmitter(EUT) was rotated through three orthogonal axes according to the requirements in Section 13.1.4.1 of ANSI C63.4-1992.

2.4 Limitation

(1) Conducted Emission (Not applicable in this report)

According to section 15.207(a) Conducted Emission Limits is as following.

Frequency range MHz	Limits dB (uV)	
	Quasi-peak	Average
0.15 to 0.50	66 to 56	56 to 46
0.50 to 5	56	46
5 to 30	60	50

Note

- The lower limit shall apply at the transition frequencies
- The limit decreases linearly with the logarithm of the frequency in the range 0.15 MHz to 0.50 MHz.

(2) Radiated Emission

- The field strength of any emission within this band (section 15.227 frequency between 26.96MHz -27.28MHz) shall not exceed 10000 micro volts/meter at 3 meters. (80dBμV at 3m) The emission limit in this paragraph is based on measurement instrumentation employing an average detector. The provisions in section 15.35 for limiting peak emissions apply.
- The field strength of any emissions which appear outside of this band shall not exceed the general radiated emission limits in section 15.209(Intentional Radiators general limit).as below.

Frequency (MHz)	Field strength μV/m	Distance (m)	Field strength at 3m dBμV/m
1.705-30	30	30	69.54
30-88	100	3	40
88-216	150	3	43.5
216-960	200	3	46
Above 960	500	3	54

- Remark:
- Emission level in dBuV/m=20 log (uV/m)
 - Measurement was performed at an antenna to the closed point of EUT distance of meters.
 - Only spurious frequency is permitted to locate within the Restricted Bands specified in provision of § 15.205
 - Emission spurious frequency which appearing within the Restricted Bands specified in provision of §15.205, then the general radiated emission limits in § 15.209 apply.

The results shown in this test report refer only to the sample(s) tested unless otherwise stated. This test report cannot be reproduced, except in full, without prior written permission of the Company.

2.5 Configuration of Tested System

Fig. 2-1 Configuration of Tested System

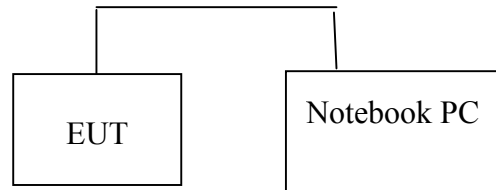

Table 2-1 Equipment Used in Tested System

Item	Equipment	Mfr/Brand	Model/ Type No.	FCC ID	Series No.	Data Cable	Power Cord
1.	Notebook PC	IBM	T30	DOC	99AMZR1	80 cm, un-shield	1.5m un-shield

The results shown in this test report refer only to the sample(s) tested unless otherwise stated. This test report cannot be reproduced, except in full, without prior written permission of the Company.

SGS Taiwan Ltd.

No. 134, Wu Kung Rd., Wuku Industrial Zone, Taipei Country, Taiwan.

TEL: 886-2-22993939

FAX: 886-2-22982698

3. Summary Of Test Results

FCC Rules	Description Of Test	Result
§ 15.207	Conducted Emission	N/A
§ 15.227	Radiated Emission	Compliant
§ 15.227	26 dB Bandwidth	Compliant

4. Description of test modes

The EUT has two operating modes, one is normal operating condition, the other is charging with operating mode.

The EUT stay in charging and continuous transmitting mode. The frequency 27.095 MHz is chosen for full testing.

The results shown in this test report refer only to the sample(s) tested unless otherwise stated. This test report cannot be reproduced, except in full, without prior written permission of the Company.

5. Conducted Emissions Test (Not apply in the report)

5.1 Measurement Procedure:

1. The EUT was placed on a table which is 0.8m above ground plane.
2. Maximum procedure was performed on the six highest emissions to ensure EUT compliance.
3. Repeat above procedures until all frequency measured were complete.

5.2 Test SET-UP (Block Diagram of Configuration)

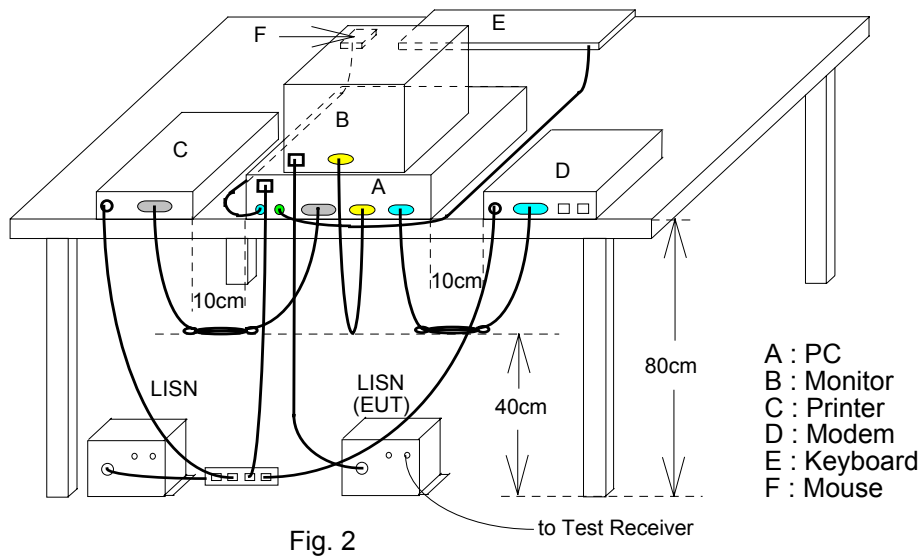

5.3 Measurement Equipment Used:

Conducted Emission Test Site					
EQUIPMENT TYPE	MFR	MODEL NUMBER	SERIAL NUMBER	LAST CAL.	CAL DUE.
EMC Analyzer	HP	8594EM	3624A00203	12/31/2003	12/30/2004
EMI Test Receiver	R&S	ESCS30	828985/004	01/15/2003	01/14/2004
LISN	Rolf-Heine	NNB-2/16Z	99012	12/30/2003	12/29/2004
LISN	Rolf-Heine	NNB-2/16Z	99013	11/06/2003	11/05/2004

5.4 Measurement Result:

The initial step in collecting conducted data is a spectrum analyzer peak scan of the measurement range. Significant peaks are then marked as shown on the following data page, and these signals are then quasi-peaked.

The results shown in this test report refer only to the sample(s) tested unless otherwise stated. This test report cannot be reproduced, except in full, without prior written permission of the Company.

AC POWER LINE CONDUCTED EMISSION TEST DATA

Operation Mode:	Charger Mode		Test Date:	Apr. 05, 2004
Temperature:	22 °C	Humidity:	63 %	Test By: Willis

FREQ MHz	Q.P. Raw dBuV	AVG Raw dBuV	Q.P. Limit dBuV	AVG Limit dBuV	Q.P. Margin dB	AVG Margin dB	NOTE
0.200	48.10		63.61		-15.51		L1
0.250	50.96	43.50	61.76	51.76	-10.80	-8.26	L1
0.320	50.71	45.20	59.71	49.71	-9.00	-4.51	L1
0.340	46.96		59.20		-12.24		L2
0.430	36.93		57.25		-20.32		L1
0.580	35.57		56.00		-20.43		L1
0.170	48.88		64.96		-16.08		L2
0.230	45.41		62.45		-17.04		L3
0.330	40.97		59.45		-18.48		L4
0.410	42.89		57.65		-14.76		L2
0.580	41.06		56.00		-14.94		L2
0.830	38.82		56.00		-17.18		L2

Remark :

- (1) Measuring frequencies from 0.15 MHz to 30MHz °
- (2) The emissions measured in frequency range from 0.15 MHz to 30MHz were made with an instrument using Qusia-Peak detector and Average detector.
- (3) “---” denotes the emission level was or more than 2dB below the Average limit, so no re-check anymore.
- (4) The IF bandwidth of SPA between 0.15MHz to 30MHz was 10KHz;
The IF bandwidth of Test Receiver between 0.15MHz to 30MHz was 9KHz;
- (5) L1 = Line One (Hot side) / L2 = Line Two (Neutral side)

The results shown in this test report refer only to the sample(s) tested unless otherwise stated. This test report cannot be reproduced, except in full, without prior written permission of the Company.

Conducted Emission Test Plot

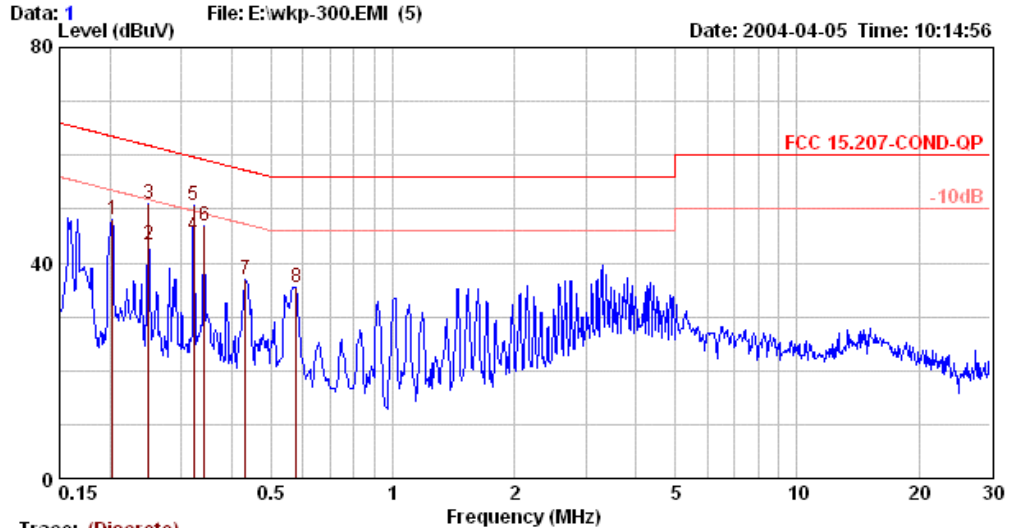

Site : 966 chamber
 Condition : FCC 15.207-COND-QP NNB-2/16Z(99012) LINE 0cm 0deg
 Applicant : Ortek
 Project No. : ER/2004/20011
 EUT Description : Wireless Calculator Mobile Mini Keypad
 EUT Model : WKP-300
 Test Mode : Charge Only
 Temp. /Humid. : 22/63
 Operator : Willis

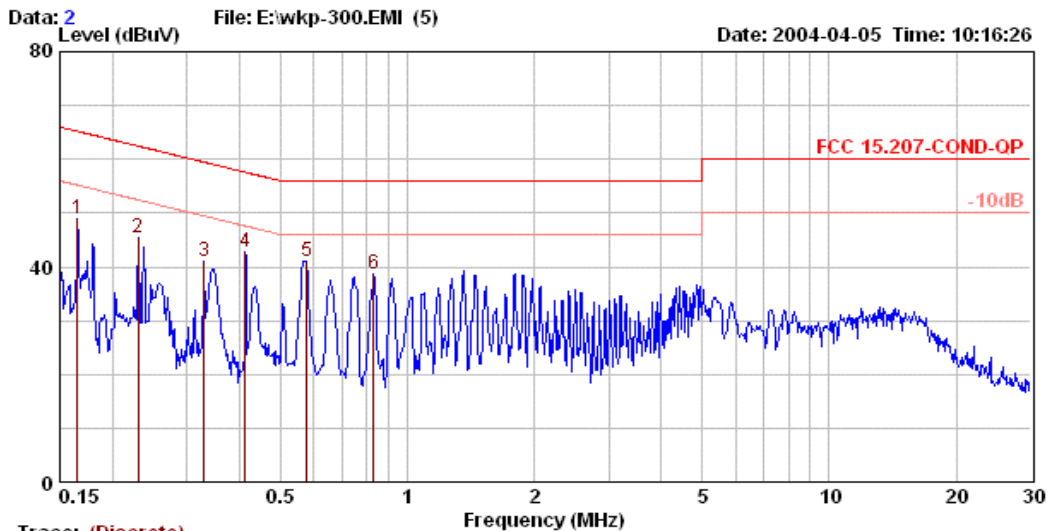

Site : 966 chamber
 Condition : FCC 15.207-COND-QP NNB-2/16Z(99012) NEUTRAL 0cm 0deg
 Applicant : Ortek
 Project No. : ER/2004/20011
 EUT Description : Wireless Calculator Mobile Mini Keypad
 EUT Model : WKP-300
 Test Mode : Charge Only
 Temp. /Humid. : 22/63
 Operator : Willis

The results shown in this test report refer only to the sample(s) tested unless otherwise stated. This test report cannot be reproduced, except in full, without prior written permission of the Company.

SGS Taiwan Ltd.

No. 134, Wu Kung Rd., Wuku Industrial Zone, Taipei Country, Taiwan.

TEL: 886-2-22993939

FAX: 886-2-22982698

AC POWER LINE CONDUCTED EMISSION TEST DATA

Operation Mode:	Charger and Operation Mode		Test Date:	Apr. 05, 2004
Temperature:	22 °C	Humidity:	63 %	Test By: Willis

FREQ MHz	Q.P. Raw dBuV	AVG Raw dBuV	Q.P. Limit dBuV	AVG Limit dBuV	Q.P. Margin dB	AVG Margin dB	NOTE
0.160	41.59		65.46		-23.87		L1
0.250	41.17		61.76		-20.59		L1
0.360	45.68		58.73		-13.05		L1
0.440	36.66		57.06		-20.40		L2
0.560	36.31		56.00		-19.69		L1
3.290	38.24		56.00		-17.76		L1
0.170	44.19		64.96		-20.77		L2
0.250	44.99		61.76		-16.77		L3
0.290	55.61	45.40	60.52	50.52	-4.91	-5.12	L4
0.350	40.53		58.96		-18.43		L2
0.490	43.37		56.17		-12.80		L2
0.580	41.26		56.00		-14.74		L2

Remark :

- (1) Measuring frequencies from 0.15 MHz to 30MHz °
- (2) The emissions measured in frequency range from 0.15 MHz to 30MHz were made with an instrument using Qusia-Peak detector and Average detector.
- (3) “---” denotes the emission level was or more than 2dB below the Average limit, so no re-check anymore.
- (4) The IF bandwidth of SPA between 0.15MHz to 30MHz was 10KHz;
The IF bandwidth of Test Receiver between 0.15MHz to 30MHz was 9KHz;
- (5) L1 = Line One (Hot side) / L2 = Line Two (Neutral side)

The results shown in this test report refer only to the sample(s) tested unless otherwise stated. This test report cannot be reproduced, except in full, without prior written permission of the Company.

Conducted Emission Test Plot

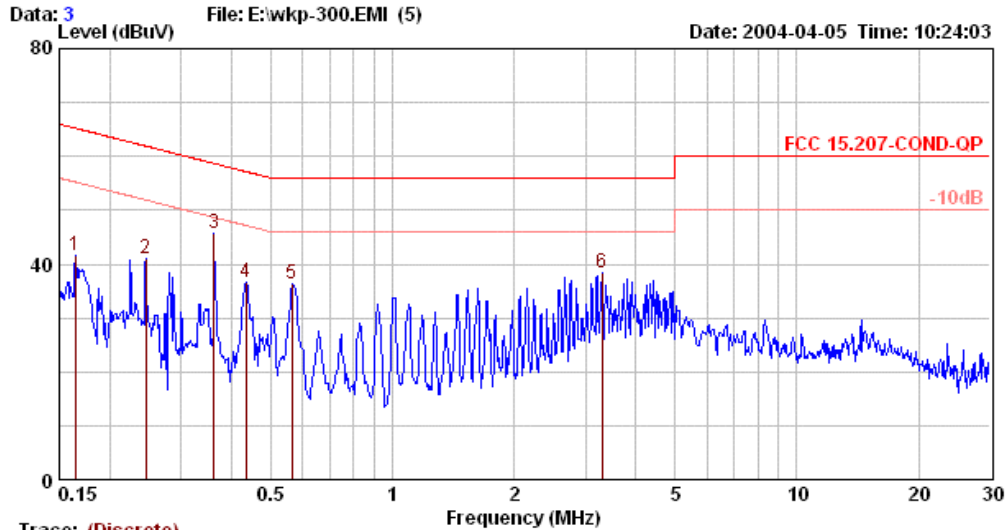

Trace: (Discrete)

Site : 966 chamber
 Condition : FCC 15.207-COND-QP NNB-2/16Z(99012) LINE 0cm 0deg
 Applicant : Ortek
 Project No. : ER/2004/20011
 EUT Description : Wireless Calculator Mobile Mini Keypad
 EUT Model : WKP-300
 Test Mode : Charge and Operating
 Temp./Humid. : 22/63
 Operator : Willis

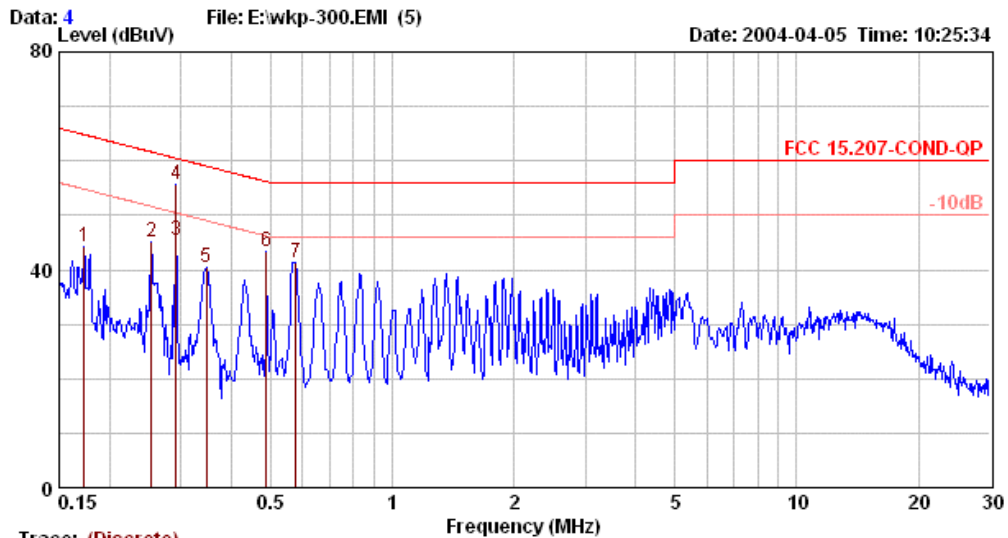

Trace: (Discrete)

Site : 966 chamber
 Condition : FCC 15.207-COND-QP NNB-2/16Z(99012) NEUTRAL 0cm 0deg
 Applicant : Ortek
 Project No. : ER/2004/20011
 EUT Description : Wireless Calculator Mobile Mini Keypad
 EUT Model : WKP-300
 Test Mode : Charge and Operating
 Temp./Humid. : 22/63
 Operator : Willis

The results shown in this test report refer only to the sample(s) tested unless otherwise stated. This test report cannot be reproduced, except in full, without prior written permission of the Company.

SGS Taiwan Ltd.

No. 134, Wu Kung Rd., Wuku Industrial Zone, Taipei Country, Taiwan.

TEL: 886-2-22993939

FAX: 886-2-22982698

6. Radiated Emission Test

6.1 Measurement Procedure

1. The EUT was placed on a turn table which is 0.8m above ground plane.
2. Maximum procedure was performed on the six highest emissions to ensure EUT compliance.
3. And also, each emission was to be maximized by changing the polarization of receiving antenna both horizontal and vertical.
4. Repeat above procedures until all frequency measured were complete.

6.2 Test SET-UP (Block Diagram of Configuration)

(A) Radiated Emission Test Set-Up, Frequency Below 30MHz

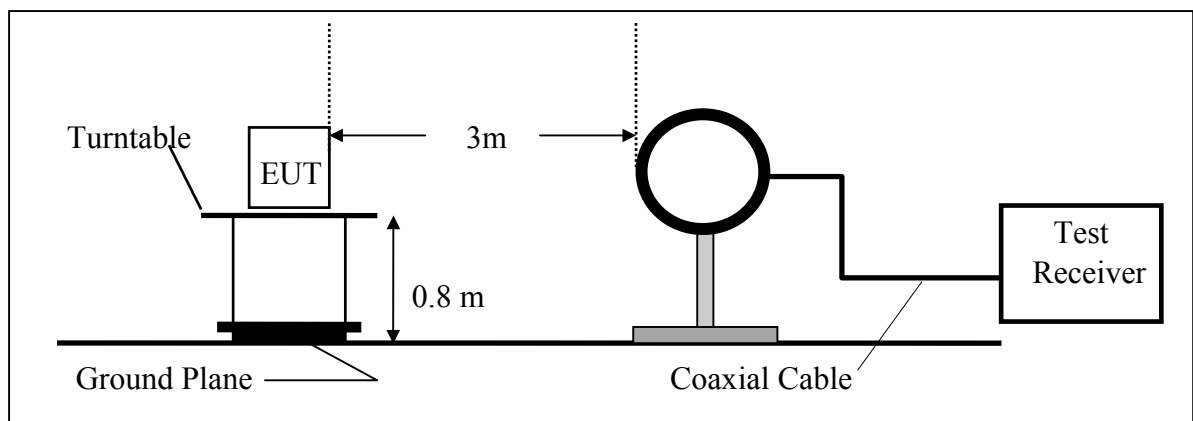

(B) Radiated Emission Test Set-Up, Frequency Below 1000MHz

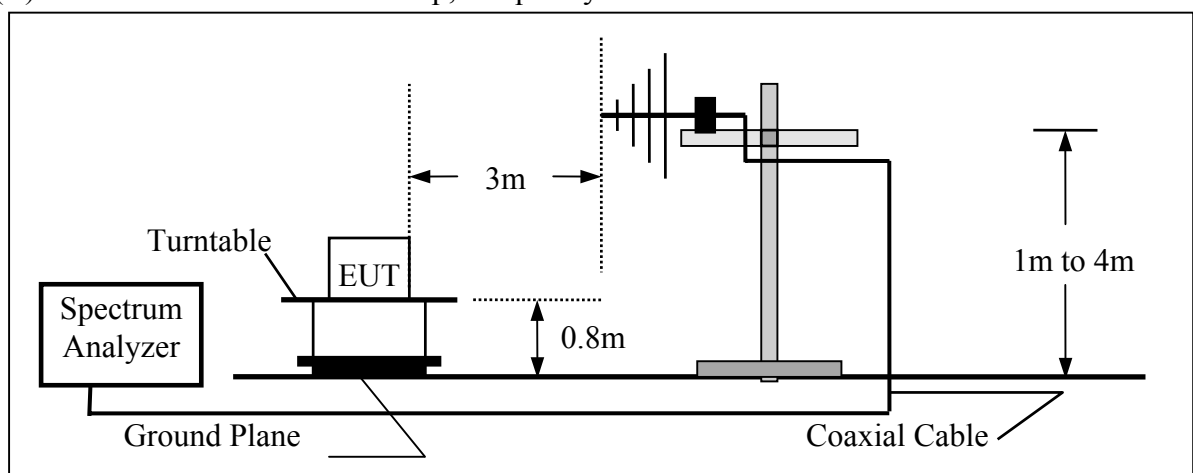

The results shown in this test report refer only to the sample(s) tested unless otherwise stated. This test report cannot be reproduced, except in full, without prior written permission of the Company.

6.3 Measurement Equipment Used:

966 Chamber					
EQUIPMENT TYPE	MFR	MODEL NUMBER	SERIAL NUMBER	LAST CAL.	CAL DUE.
Spectrum Analyzer	R&S	FSP 40	100034	05/27/2003	05/26/2004
Spectrum Analyzer	Agilent	E7405A	US41160416	08/27/2003	08/27/2004
Loop Antenna	Messtec	FLA30	03/10086	03/06/2003	03/05/2004
Bilog Antenna	SCHWAZBECK	VULB9163	152	06/03/2003	06/02/2004
Bilog Antenna	SCHWAZBECK	VULB9160		06/03/2003	06/02/2004
Pre-Amplifier	HP	8447D	2944A09469	07/19/2003	07/18/2004
Turn Table	HD	DT420	N/A	N.C.R	N.C.R
Antenna Tower	HD	MA240-N	240/657	N.C.R	N.C.R
Controller	HD	HD100	N/A	N.C.R	N.C.R
Low Loss Cable	HUBER+SUHNER	SUCOFLEX 104PEA-10M	10m	10/9/2003	10/08/2004
Low Loss Cable	HUBER+SUHNER	SUCOFLEX 104PEA-3M	3m	10/9/2003	10/08/2004
Site NSA	SGS	966 chamber	N/A	11/17/2003	11/16/2004
Site NSA	SGS	10m Open-Site	N/A	10/02/2003	10/01/2004

6.4 Field Strength Calculation

The field strength is calculated by adding the Antenna Factor and Cable Factor and subtracting the Amplifier Gain and Duty Cycle Correction Factor (if any) from the measured reading. The basic equation with a sample calculation is as follows:

$$FS = RA + AF + CL - AG$$

Where	FS = Field Strength	CL = Cable Attenuation Factor (Cable Loss)
	RA = Reading Amplitude	AG = Amplifier Gain
	AF = Antenna Factor	

The results shown in this test report refer only to the sample(s) tested unless otherwise stated. This test report cannot be reproduced, except in full, without prior written permission of the Company.

6.5 Measurement Result

Operation Mode:	Transmitting Mode	Test Date :	Feb. 08,2004
Fundamental Frequency:	27.095 MHz	Test By:	Willis
Temperature :	25 °C	Pol:	Vertical
Humidity :	65 %		
Judgment :	Passed by <u> -7.19 </u> dB at <u> 144.46 </u> MHz		

Freq. (MHz)	Ant.Pol. H/V	Detector Mode (PK/AV/QP)	Reading (dBUV)	Factor (dB)	Actual FS (dBUV/m)	Limit@3m (dBUV/m)	Safe Margin (dB)	Note
27.095	V	Peak	77.20	-13.71	63.49	80.00	-16.51	F
54.190	V	Peak	--		0.00	40.00	-40.00	H
81.285	V	Peak	--		0.00	40.00	-40.00	H
108.380	V	Peak	--		0.00	43.50	-43.50	H
135.475	V	Peak	--		0.00	43.50	-43.50	H
162.570	V	Peak	--		0.00	43.50	-43.50	H
189.665	V	Peak	--		0.00	43.50	-43.50	H
216.760	V	Peak	--		0.00	46.00	-46.00	H
243.855	V	Peak	--		0.00	46.00	-46.00	H
270.950	V	Peak	--		0.00	46.00	-46.00	H
62.900	V	Peak	47.78	-15.08	32.70	40.00	-7.30	H
144.460	V	Peak	53.58	-17.27	36.31	43.50	-7.19	H
199.750	V	Peak	49.09	-15.08	34.01	43.50	-9.49	H
400.540	V	Peak	41.96	-10.13	31.83	46.00	-14.17	H
506.270	V	Peak	41.82	-8.29	33.53	46.00	-12.47	H
599.390	V	Peak	36.31	-5.98	30.33	46.00	-15.67	H

Remark :

- (1) Measuring frequencies from 25 MHz to the 1GHz °
- (2) Radiated emissions measured in frequency range from 25 MHz to 1000MHz were made with an instrument using Peak detector mode.
- (3) "F" denotes fundamental frequency; "H" denotes spurious frequency. "E" denotes band edge frequency.
- (4) Data of measurement within this frequency range shown " - " in the table above means the reading of emissions are attenuated more than 20dB below the permissible limits or the field strength is too small to be measured.
- (5) The IF bandwidth of SPA between 25MHz to 30MHz was 10KHz; 30MHz to 1GHz was 100KHz.

The results shown in this test report refer only to the sample(s) tested unless otherwise stated. This test report cannot be reproduced, except in full, without prior written permission of the Company.

6.6 Measurement Result

Operation Mode:	Transmitting Mode	Test Date :	Feb. 08, 2004
Fundamental Frequency:	27.095 MHz	Test By:	Willis
Temperature :	25 °C	Pol:	Horizontal
Humidity :	65 %		
Judgment :	Passed by <u> -2.88 </u> dB at <u> 199.75 </u> MHz		

Freq. (MHz)	Ant.Pol. H/V	Detector Mode (PK/AV/QP)	Reading (dBuV)	Factor (dB)	Actual FS (dBuV/m)	Limit@3m (dBuV/m)	Safe Margin (dB)	Note
27.095	H	Peak	65.87	-13.71	52.16	80.00	-27.84	F
54.190	H	Peak	--		0.00	40.00	-40.00	H
81.285	H	Peak	--		0.00	40.00	-40.00	H
108.380	H	Peak	--		0.00	43.50	-43.50	H
135.475	H	Peak	--		0.00	43.50	-43.50	H
162.570	H	Peak	--		0.00	43.50	-43.50	H
189.665	H	Peak	--		0.00	43.50	-43.50	H
216.760	H	Peak	--		0.00	46.00	-46.00	H
243.855	H	Peak	--		0.00	46.00	-46.00	H
270.950	H	Peak	--		0.00	46.00	-46.00	H
66.860	H	Peak	48.74	-16.60	32.14	40.00	-7.86	H
199.750	H	QP	55.70	-15.08	40.62	43.50	-2.88	H
230.790	H	Peak	47.51	-13.85	33.66	46.00	-12.34	H
366.590	H	Peak	51.49	-10.76	40.73	46.00	-5.27	H
400.540	H	Peak	52.60	-10.13	42.47	46.00	-3.53	H
800.180	H	Peak	34.90	-2.97	31.93	46.00	-14.07	H

Remark :

- (1) Measuring frequencies from 25 MHz to the 1GHz °
- (2) Radiated emissions measured in frequency range from 25 MHz to 1000MHz were made with an instrument using Peak detector mode.
- (3) "F" denotes fundamental frequency; "H" denotes spurious frequency. "E" denotes band edge frequency.
- (4) Data of measurement within this frequency range shown " - " in the table above means the reading of emissions are attenuated more than 20dB below the permissible limits or the field strength is too small to be measured.
- (5) The IF bandwidth of SPA between 25MHz to 30MHz was 10KHz; 30MHz to 1GHz was 100KHz.

The results shown in this test report refer only to the sample(s) tested unless otherwise stated. This test report cannot be reproduced, except in full, without prior written permission of the Company.

7. Occupied Bandwidth

7.1 Measurement Procedure

1. The EUT was placed on a turn table which is 0.8m above ground plane.
2. Set EUT as normal operation
3. Set SPA Center Frequency = fundamental frequency, RBW, VBW= 10KHz, Span =100KHz.
4. Set SPA Max hold. Mark peak, -26dB.

7.2 Test SET-UP (Block Diagram of Configuration)

Same as 4.2 Radiated Emission Measurement.

7.3 Measurement Equipment Used:

Same as 4.2 Radiated Emission Measurement.

7.4 Measurement Results

26dB bandwidth = 57.3 KHz

Refer to attached data chart.

The results shown in this test report refer only to the sample(s) tested unless otherwise stated. This test report cannot be reproduced, except in full, without prior written permission of the Company.

26dB Band Width Test Data

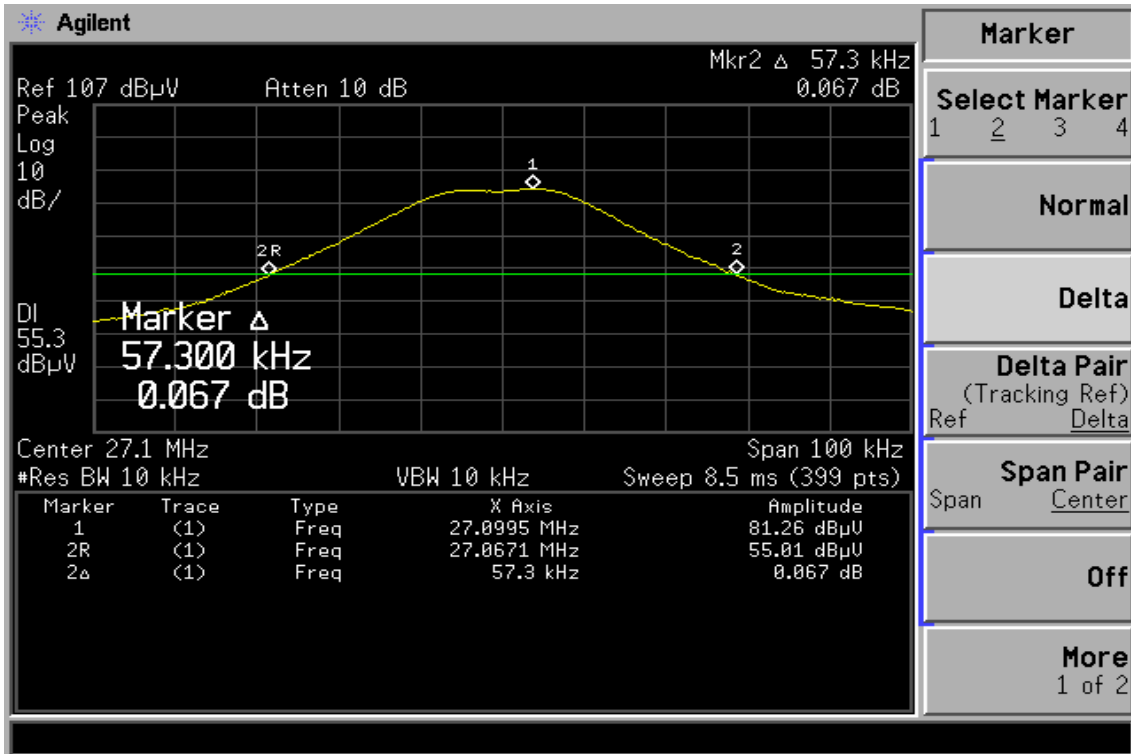

The results shown in this test report refer only to the sample(s) tested unless otherwise stated. This test report cannot be reproduced, except in full, without prior written permission of the Company.

SGS Taiwan Ltd.

No. 134, Wu Kung Rd., Wuku Industrial Zone, Taipei Country, Taiwan.

TEL: 886-2-22993939

FAX: 886-2-22982698