

ELECTROMAGNETIC EMISSIONS COMPLIANCE REPORT**INTENTIONAL RADIATOR CERTIFICATION TO
FCC PART 15 SUBPART C REQUIREMENT**

OF

Product Name: Wireless Calculator Keypad

Brand Name: ORTEK

Model Name: WKP-270-02, WPM-700-02, WS-9600-02,
WPM-800-02, WKP-280-02

Model Differences: The variant models depend on different trader
in the market

FCC ID: GM8WKP270-02

Report No.: ER/2007/70018

Issue Date: Jul. 24, 2007

FCC Rule Part: §15.227

Prepared for Ortek Technology Inc.
13F, Number 150, Jian Yi Rd., Chung Ho City,
Taipei Hsien, Taiwan, R.O.C.

Prepared by SGS Taiwan Ltd.
No. 134, Wu Kung Rd., Wuku Industrial Zone,
Taipei County, Taiwan.

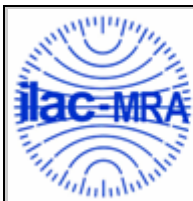

Note: This report shall not be reproduced except in full, without the written approval of SGS Taiwan Ltd. This document may be altered or revised by SGS Taiwan Ltd. personnel only, and shall be noted in the revision section of the document.

VERIFICATION OF COMPLIANCE

Applicant: Ortek Technology Inc.
13F, Number 150, Jian Ti Rd., Chung Ho City, Taipei Hsien, Taiwan,
R.O.C.

Product Description: Wireless Calculator Keypad

FCC ID Number: GM8WKP270-02

Brand Name: ORTEK

Model No.: WKP-270-02, WPM-700-02, WS-9600-02, WPM-800-02, WKP-280-02

Model Difference: The variant models depend on different trader in the market

File Number: ER/2007/70018

Date of Test: Jul. 17, 2007 ~ Jul. 24, 2007

Date of EUT Received: Jul. 24, 2007

We hereby certify that:

The above equipment was tested by SGS Taiwan Ltd. The test data, data evaluation, test procedures, and equipment configurations shown in this report were made in accordance with the procedures given in ANSI C63.4 (2003) and the energy emitted by the sample EUT tested as described in this report is in compliance with conducted and radiated emission limits of FCC Rules Part 15.227

The test results of this report relate only to the tested sample identified in this report.

<i>Test By:</i>	<i>(original Signature)</i>	<i>Date</i>	Jul. 24, 2007

	<i>Danny Yeh / Engineer</i>		
<i>Prepared By:</i>	<i>(original Signature)</i>	<i>Date</i>	Jul. 24, 2007

	<i>Eva Kao / Sr. Engineer</i>		
<i>Approved By</i>	<i>(original Signature)</i>	<i>Date</i>	Jul. 24, 2007

	<i>Vincent Su / Manager</i>		

Version

Version No.	Date
00	Jul. 24, 2007
01	Aug. 20, 2007

This document is issued by the Company subject to its General Conditions of Service printed overleaf or available on request and accessible at www.sgs.com. Attention is drawn to the limitations of liability, indemnification, and Jurisdictional issued defined therein. Unless otherwise stated, the results shown in this test report refer only to the sample(s) tested. This document cannot be reproduced except in full, without prior approval of Company. Any unauthorized alteration, forgery or falsification of the content or appearance of this report is unlawful and offenders may be prosecuted to the fullest extent of the law. 此報告是遵循本公司訂定之通用服務條款所製作發放，請注意此條款列印於背面，亦可在www.sgs.com中查閱。將本公司之義務，免責，管轄權皆明確規範之。除非另有說明，此報告結果僅對檢驗之樣品負責。本報告未經本公司書面許可，不可部份複製。對本報告內容或外觀之任何未經授權之變更、偽造、竄改皆屬非法，違犯者將會被依法追訴。

Table of Contents

1.	GENERAL INFORMATION	5
1.1	PRODUCT DESCRIPTION	5
1.2	RELATED SUBMITTAL(S) / GRANT (S)	5
1.3	TEST METHODOLOGY.....	5
1.4	TEST FACILITY	5
1.5	SPECIAL ACCESSORIES	5
1.6	EQUIPMENT MODIFICATIONS	5
2.	SYSTEM TEST CONFIGURATION	6
2.1	EUT CONFIGURATION	6
2.2	EUT EXERCISE	6
2.3	TEST PROCEDURE.....	6
2.4	LIMITATION	6
2.5	CONFIGURATION OF TESTED SYSTEM.....	8
3.	SUMMARY OF TEST RESULTS	9
4.	DESCRIPTION OF TEST MODES	9
5.	CONDUCTED EMISSIONS TEST	10
5.1	MEASUREMENT PROCEDURE:	10
5.2	TEST SET-UP (BLOCK DIAGRAM OF CONFIGURATION)	10
5.3	MEASUREMENT EQUIPMENT USED:	10
5.4	MEASUREMENT RESULT:	10
6.	RADIATED EMISSION TEST	11
6.1	MEASUREMENT PROCEDURE.....	11
6.2	TEST SET-UP (BLOCK DIAGRAM OF CONFIGURATION)	11
6.3	MEASUREMENT EQUIPMENT USED:	12
6.4	FIELD STRENGTH CALCULATION	12
6.5	MEASUREMENT RESULT	13
7.	OCCUPIED BANDWIDTH.....	15
7.1	MEASUREMENT PROCEDURE.....	15
7.2	TEST SET-UP (BLOCK DIAGRAM OF CONFIGURATION)	15
7.3	MEASUREMENT EQUIPMENT USED:	15
7.4	MEASUREMENT RESULTS.....	15

This document is issued by the Company subject to its General Conditions of Service printed overleaf or available on request and accessible at www.sgs.com. Attention is drawn to the limitations of liability, indemnification, and Jurisdictional issued defined therein. Unless otherwise stated, the results shown in this test report refer only to the sample(s) tested. This document cannot be reproduced except in full, without prior approval of Company. Any unauthorized alteration, forgery or falsification of the content or appearance of this report is unlawful and offenders may be prosecuted to the fullest extent of the law. 此報告是遵循本公司訂定之通用服務條款所製作發放，請注意此條款列印於背面，亦可在www.sgs.com中查閱。將本公司之義務，免責，管轄權皆明確規範之。除非另有說明，此報告結果僅對檢驗之樣品負責。本報告未經本公司書面許可，不可部份複製。對本報告內容或外觀之任何未經授權之變更、偽造、竄改皆屬非法，違犯者將會被依法追訴。

1. GENERAL INFORMATION

1.1 Product Description

The Ortek Technology Inc. Model: WKP-270-02, WPM-700-02, WS-9600-02, WPM-800-02, WKP-280-02 (referred to as the EUT in this report) The EUT is an short range, lower power, Wireless Calculator Keypad designed as an " Input Device. It is designed by way of utilizing the FSK modulation achieves the system operating.

A major technical descriptions of EUT is described as following:

- A). Operation Frequency: 27.095MHz, one channel.
- B). Modulation : Frequency Shifting Key (FSK) Modulation
- C). Antenna Designation: Non-User Replaceable (Fixed)
- D). Power Supply: 1.5 Vdc by AAA Battery.

1.2 Related Submittal(s) / Grant (s)

This submittal(s) (test report) is intended for FCC ID: **GM8WKP270-02** filing to comply with Section 15.227 of the FCC Part 15, Subpart C Rules. The composite system (receiver) is compliance with Subpart B is authorized under a DoC procedure.

1.3 Test Methodology

Both conducted and radiated testing were performed according to the procedures in ANSI C63.4 (20031992). Radiated testing was performed at an antenna to EUT distance 3 meters.

1.4 Test Facility

The open area test site and conducted measurement facility used to collect the radiated data is located on the address of SGS Taiwan Ltd. No. 134, Wu Kung Rd., Wuku Industrial Zone, Taipei Country, Taiwan. The Open Area Test Sites and the Line Conducted labs are constructed and calibrated to meet the FCC requirements in documents ANSI C63.4: 2003 and CISPR 22/EN 55022 requirements. Site No. 1(3 &10 meters) Registration Number: 94644, Both OATS and Anechoic chamber (3 meters) was accredited by TAF (0513).

1.5 Special Accessories

Not available for this EUT intended for grant.

1.6 Equipment Modifications

Not available for this EUT intended for grant.

2. System Test Configuration

2.1 EUT Configuration

The EUT configuration for testing is installed on RF field strength measurement to meet the Commissions requirement and operating in a manner which intends to maximize its emission characteristics in a continuous normal application.

2.2 EUT Exercise

The Transmitter was operated in the normal operating mode. the Tx frequency was fixed which was for the purpose of the measurements.

2.3 Test Procedure

2.3.1 Conducted Emissions

The EUT is a placed on as turn table which is 0.8 m above ground plane. According to the requirements in Section 7 and 13 of ANSI C63.4-2003. Conducted emissions from the EUT measured in the frequency range between 0.15 MHz and 30MHz using CISPR Quasi-Peak and average detector mode.

2.3.2 Radiated Emissions

The EUT is a placed on as turn table which is 0.8 m above ground plane. The turn table shall rotate 360 degrees to determine the position of maximum emission level. EUT is set 3m away from the receiving antenna which varied from 1m to 4m to find out the highest emission. And also, each emission was to be maximized by changing the polarization of receiving antenna both horizontal and vertical. In order to find out the max. emission, the relative positions of this hand-held transmitter(EUT) was rotated through three orthogonal axes according to the requirements in Section 8 and 13 of ANSI C63.4-2003.

2.4 Limitation

(1) Conducted Emission

According to section 15.207(a) Conducted Emission Limits is as following.

Frequency range MHz	Limits dB (uV)	
	Quasi-peak	Average
0.15 to 0.50	66 to 56	56 to 46
0.50 to 5	56	46
5 to 30	60	50

Note

- 1.The lower limit shall apply at the transition frequencies
- 2.The limit decreases linearly with the logarithm of the frequency in the range 0.15 MHz to 0.50 MHz.

(2) Radiated Emission

- a. The field strength of any emission within this band (section 15.227 frequency between 26.96MHz -27.28MHz) shall not exceed 10000 micro volts/meter at 3 meters. (80dB μ V at 3m) The emission limit in this paragraph is based on measurement instrumentation employing an average detector. The provisions in section 15.35 for limiting peak emissions apply.
- b. The field strength of any emissions which appear outside of this band shall not exceed the general radiated emission limits in section 15.209(Intentional Radiators general limit).as below.

Frequency (MHz)	Field strength μ V/m	Distance (m)	Field strength at 3m dB μ V/m
1.705-30	30	30	69.54
30-88	100	3	40
88-216	150	3	43.5
216-960	200	3	46
Above 960	500	3	54

- Remark:
1. Emission level in dBuV/m=20 log (uV/m)
 2. Measurement was performed at an antenna to the closed point of EUT distance of meters.
 3. Only spurious frequency is permitted to locate within the Restricted Bands specified in provision of ξ 15.205
 4. Emission spurious frequency which appearing within the Restricted Bands specified in provision of ξ 15.205, then the general radiated emission limits in ξ 15.209 apply.

This document is issued by the Company subject to its General Conditions of Service printed overleaf or available on request and accessible at www.sgs.com. Attention is drawn to the limitations of liability, indemnification, and Jurisdictional issued defined therein. Unless otherwise stated, the results shown in this test report refer only to the sample(s) tested. This document cannot be reproduced except in full, without prior approval of Company. Any unauthorized alteration, forgery or falsification of the content or appearance of this report is unlawful and offenders may be prosecuted to the fullest extent of the law. 此報告是遵循本公司訂定之通用服務條款所製作發放，請注意此條款列印於背面，亦可在www.sgs.com中查閱。將本公司之義務，免責，管轄權皆明確規範之。除非另有說明，此報告結果僅對檢驗之樣品負責。本報告未經本公司書面許可，不可部份複製。對本報告內容或外觀之任何未經授權之變更、偽造、竄改皆屬非法，違犯者將會被依法追訴。

2.5 Configuration of Tested System

Fig. 2-1 Configuration of Tested System

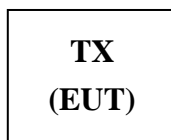

Table 2-1 Equipment Used in Tested System

Equipment	Mfr/Brand	Model/ Type No.	FCC ID	Series No.
N/A				

This document is issued by the Company subject to its General Conditions of Service printed overleaf or available on request and accessible at www.sgs.com. Attention is drawn to the limitations of liability, indemnification, and Jurisdictional issued defined therein. Unless otherwise stated, the results shown in this test report refer only to the sample(s) tested. This document cannot be reproduced except in full, without prior approval of Company. Any unauthorized alteration, forgery or falsification of the content or appearance of this report is unlawful and offenders may be prosecuted to the fullest extent of the law. 此報告是遵循本公司訂定之通用服務條款所製作發放，請注意此條款列印於背面，亦可在www.sgs.com中查閱。將本公司之義務，免責，管轄權皆明確規範之。除非另有說明，此報告結果僅對檢驗之樣品負責。本報告未經本公司書面許可，不可部份複製。對本報告內容或外觀之任何未經授權之變更、偽造、竄改皆屬非法，違犯者將會被依法追訴。

3. Summary Of Test Results

FCC Rules	Description Of Test	Result
§ 15.207	Conducted Emission	Compliant
§ 15.227	Radiated Emission	Compliant
§ 15.227	26 dB Bandwidth	Compliant

4. Description of test modes

The EUT stay in continuous transmitting mode. The frequency 27.095 MHz is chosen for radiated emission testing.

This document is issued by the Company subject to its General Conditions of Service printed overleaf or available on request and accessible at www.sgs.com. Attention is drawn to the limitations of liability, indemnification, and Jurisdictional issued defined therein. Unless otherwise stated, the results shown in this test report refer only to the sample(s) tested. This document cannot be reproduced except in full, without prior approval of Company. Any unauthorized alteration, forgery or falsification of the content or appearance of this report is unlawful and offenders may be prosecuted to the fullest extent of the law. 此報告是遵循本公司訂定之通用服務條款所製作發放，請注意此條款列印於背面，亦可在www.sgs.com中查閱。將本公司之義務，免責，管轄權皆明確規範之。除非另有說明，此報告結果僅對檢驗之樣品負責。本報告未經本公司書面許可，不可部份複製。對本報告內容或外觀之任何未經授權之變更、偽造、竄改皆屬非法，違犯者將會被依法追訴。

5. Conducted Emissions Test

5.1 Measurement Procedure:

1. The EUT was placed on a table which is 0.8m above ground plane.
2. Maximum procedure was performed on the six highest emissions to ensure EUT compliance.
3. Repeat above procedures until all frequency measured were complete.

5.2 Test SET-UP (Block Diagram of Configuration)

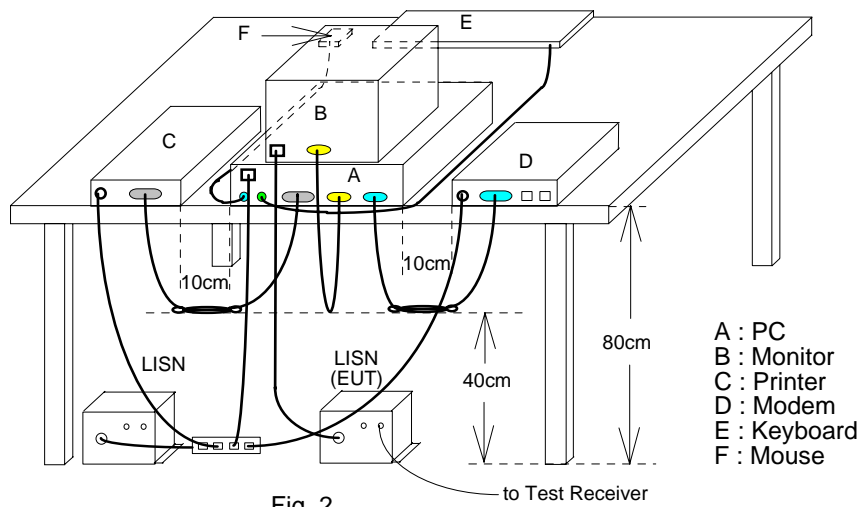

5.3 Measurement Equipment Used:

Conducted Emission Test Site					
EQUIPMENT TYPE	MFR	MODEL NUMBER	SERIAL NUMBER	LAST CAL.	CAL DUE.
EMC Analyzer	HP	8594EM	3624A00203	09/02/2006	09/03/2007
EMI Test Receiver	R&S	ESCS30	828985/004	06/09/2007	06/10/2008
Transient Limiter	HP	11947A	3107A02062	09/02/2006	09/03/2007
LISN	Rolf-Heine	NNB-2/16Z	99012	12/31/2006	12/30/2007
LISN	Rolf-Heine	NNB-2/16Z	99013	01/10/2007	01/09/2008
Coaxial Cables	FCC	FCC-LISN-50/250-25-2-01	04034	01/11/2007	01/10/2008

5.4 Measurement Result:

N/A, the power supply is 1.5vdc by AAA battery.

This document is issued by the Company subject to its General Conditions of Service printed overleaf or available on request and accessible at www.sgs.com. Attention is drawn to the limitations of liability, indemnification, and Jurisdictional issued defined therein. Unless otherwise stated, the results shown in this test report refer only to the sample(s) tested. This document cannot be reproduced except in full, without prior approval of Company. Any unauthorized alteration, forgery or falsification of the content or appearance of this report is unlawful and offenders may be prosecuted to the fullest extent of the law. 此報告是遵循本公司訂定之通用服務條款所製作發放，請注意此條款列印於背面，亦可在www.sgs.com中查閱。將本公司之義務，免責，管轄權皆明確規範之。除非另有說明，此報告結果僅對檢驗之樣品負責。本報告未經本公司書面許可，不可部份複製。對本報告內容或外觀之任何未經授權之變更、偽造、竄改皆屬非法，違犯者將會被依法追訴。

6. Radiated Emission Test

6.1 Measurement Procedure

1. The EUT was placed on a turn table which is 0.8m above ground plane.
2. Maximum procedure was performed on the six highest emissions to ensure EUT compliance.
3. And also, each emission was to be maximized by changing the polarization of receiving antenna both horizontal and vertical.
4. Repeat above procedures until all frequency measured were complete.

6.2 Test SET-UP (Block Diagram of Configuration)

(A) Radiated Emission Test Set-Up, Frequency Below 30MHz

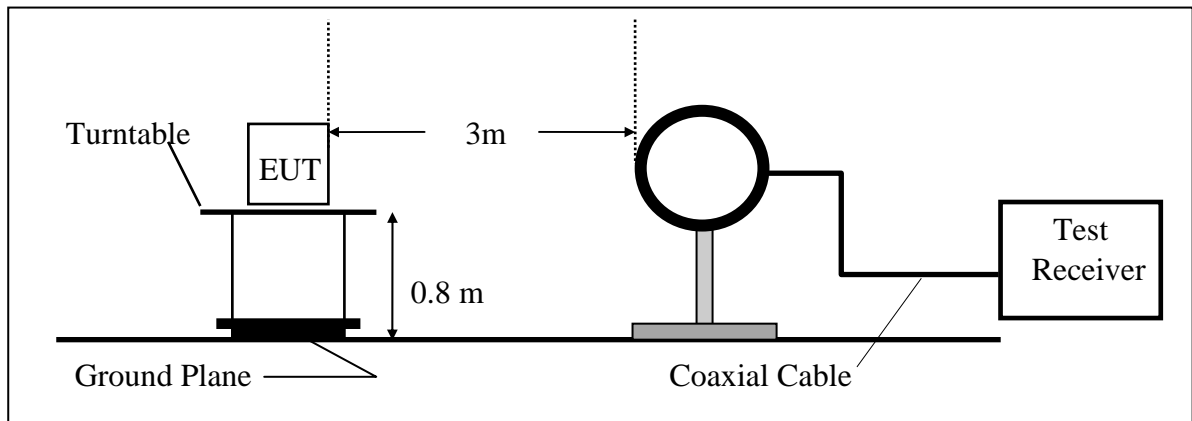

(B) Radiated Emission Test Set-Up, Frequency Below 1000MHz

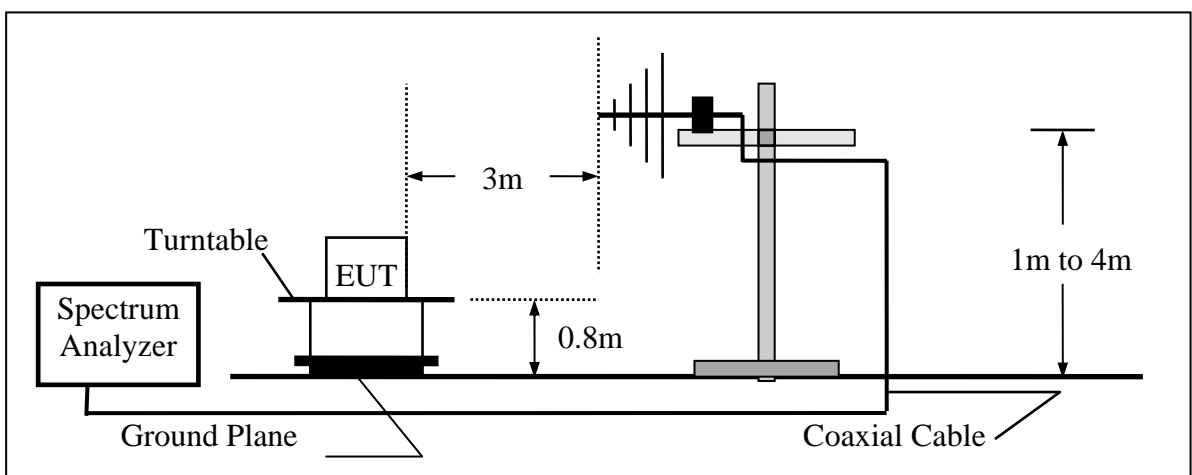

This document is issued by the Company subject to its General Conditions of Service printed overleaf or available on request and accessible at www.sgs.com. Attention is drawn to the limitations of liability, indemnification, and Jurisdiction issued defined therein. Unless otherwise stated, the results shown in this test report refer only to the sample(s) tested. This document cannot be reproduced except in full, without prior approval of Company. Any unauthorized alteration, forgery or falsification of the content or appearance of this report is unlawful and offenders may be prosecuted to the fullest extent of the law. 此報告是遵循本公司訂定之通用服務條款所製作發放，請注意此條款列印於背面，亦可在www.sgs.com中查閱。將本公司之義務，免責，管轄權皆明確規範之。除非另有說明，此報告結果僅對檢驗之樣品負責。本報告未經本公司書面許可，不可部份複製。對本報告內容或外觀之任何未經授權之變更、偽造、竄改皆屬非法，違犯者將會被依法追訴。

6.3 Measurement Equipment Used:

966 Chamber					
EQUIPMENT TYPE	MFR	MODEL NUMBER	SERIAL NUMBER	LAST CAL.	CAL DUE.
Spectrum Analyzer	Agilent	E4446A	MY43360126	04/27/2007	04/27/2008
Spectrum Analyzer	R&S	FSP 40	100034	05/27/2007	05/26/2008
Spectrum Analyzer	Agilent	E7405A	US41160416	07/04/2007	07/03/2008
Loop Antenna	MESSTEC	FLA30	03/10086	06/06/2007	06/05/2009
Bilog Antenna	SCHWAZBECK	VULB9160	3224	11/14/2006	11/13/2007
Horn antenna	Schwarzbeck	BBHA 9120D	309/320	12/14/2006	12/13/2007
Horn antenna	Schwarzbeck	BBHA 9170	184/185	12/13/2006	12/12/2007
Pre-Amplifier	HP	8447D	2944A09469	07/19/2007	07/18/2008
Pre-Amplifier	HP	8494B	3008A00578	02/26/2007	02/25/2008
Turn Table	HD	DT420	N/A	N.C.R	N.C.R
Antenna Tower	HD	MA240-N	240/657	N.C.R	N.C.R
Controller	HD	HD100	N/A	N.C.R	N.C.R
Low Loss Cable	HUBER+SUHNER	SUCOFLEX 104PEA-10M	10m	10/09/2006	10/08/2007
Low Loss Cable	HUBER+SUHNER	SUCOFLEX 104PEA-3M	3m	10/09/2006	10/08/2007
Site NSA	SGS	966 chamber	N/A	11/17/2006	11/16/2007

6.4 Field Strength Calculation

The field strength is calculated by adding the Antenna Factor and Cable Factor and subtracting the Amplifier Gain and Duty Cycle Correction Factor (if any) from the measured reading. The basic equation with a sample calculation is as follows:

$$FS = RA + AF + CL - AG$$

Where	FS = Field Strength	CL = Cable Attenuation Factor (Cable Loss)
	RA = Reading Amplitude	AG = Amplifier Gain
	AF = Antenna Factor	

This document is issued by the Company subject to its General Conditions of Service printed overleaf or available on request and accessible at www.sgs.com. Attention is drawn to the limitations of liability, indemnification, and Jurisdictional issued defined therein. Unless otherwise stated, the results shown in this test report refer only to the sample(s) tested. This document cannot be reproduced except in full, without prior approval of Company. Any unauthorized alteration, forgery or falsification of the content or appearance of this report is unlawful and offenders may be prosecuted to the fullest extent of the law. 此報告是遵循本公司訂定之通用服務條款所製作發放，請注意此條款列印於背面，亦可在www.sgs.com中查閱。將本公司之義務，免責，管轄權皆明確規範之。除非另有說明，此報告結果僅對檢驗之樣品負責。本報告未經本公司書面許可，不可部份複製。對本報告內容或外觀之任何未經授權之變更、偽造、竄改皆屬非法，違犯者將會被依法追訴。

6.5 Measurement Result

Operation Mode: Transmitting Mode Test Date : Jul. 18, 2007
 Fundamental Frequency: 27.095 MHz Test By: Danny
 Temperature : 25 °C Pol: Vertical
 Humidity : 65 %

Freq. (MHz)	Ant.Pol. H/V	Detector Mode (PK/AV/QP)	Reading (dBuV)	Factor (dB)	Actual FS (dBuV/m)	Limit@3m (dBuV/m)	Safe Margin (dB)	Note
27.09	V	Peak	53.18	-14.88	38.30	80.00	-41.70	F
54.18	V	Peak	--					
81.27	V	Peak	--					
108.36	V	Peak	42.16	-16.87	25.29	43.50	-18.21	H
135.45	V	Peak	--					
162.54	V	Peak	--					
189.63	V	Peak	--					
216.72	V	Peak	--					
243.81	V	Peak	--					
270.90	V	Peak	--					
30.00	V	Peak	49.74	-14.97	34.77	40.00	-5.23	E
58.31	V	Peak	41.55	-14.66	26.89	40.00	-13.11	E

Remark :

- (1) Measuring frequencies from 25 MHz to the 1GHz .
- (2) Radiated emissions measured in frequency range from 25 MHz to 1000MHz were made with an instrument using Peak detector mode.
- (3) "F" denotes fundamental frequency; "H" denotes spurious frequency. "E" denotes band edge frequency.
- (4) Data of measurement within this frequency range shown " - " in the table above means the reading of emissions are attenuated more than 20dB below the permissible limits or the field strength is too small to be measured.
- (5) The IF bandwidth of SPA between 25MHz to 30MHz was 10KHz; 30MHz to 1GHz was 100KHz.

This document is issued by the Company subject to its General Conditions of Service printed overleaf or available on request and accessible at www.sgs.com. Attention is drawn to the limitations of liability, indemnification, and Jurisdictional issued defined therein. Unless otherwise stated, the results shown in this test report refer only to the sample(s) tested. This document cannot be reproduced except in full, without prior approval of Company. Any unauthorized alteration, forgery or falsification of the content or appearance of this report is unlawful and offenders may be prosecuted to the fullest extent of the law. 此報告是遵循本公司訂定之通用服務條款所製作發放，請注意此條款列印於背面，亦可在www.sgs.com中查閱。將本公司之義務，免責，管轄權皆明確規範之。除非另有說明，此報告結果僅對檢驗之樣品負責。本報告未經本公司書面許可，不可部份複製。對本報告內容或外觀之任何未經授權之變更、偽造、竄改皆屬非法，違犯者將會被依法追訴。

Operation Mode: Transmitting Mode
 Fundamental Frequency: 27.095 MHz
 Temperature : 25 °C
 Humidity : 65 %

Test Date : Jul. 18, 2007
 Test By: Danny
 Pol: Horizontal

Freq. (MHz)	Ant.Pol. H/V	Detector		Factor (dB)	Actual FS (dBuV/m)	Limit@3m (dBuV/m)	Safe Margin (dB)	Note
		Mode (PK/AV/QP)	Reading (dBuV)					
27.09	H	Peak	70.51	-14.88	55.63	80.00	-24.37	F
54.18	H	Peak	--					
81.27	H	Peak	--					
108.36	H	Peak	42.16	-16.87	25.29	43.50	-18.21	H
135.45	H	Peak	--					
162.54	H	Peak	--					
189.63	H	Peak	--					
216.72	H	Peak	--					
243.81	H	Peak	--					
270.90	H	Peak	--					
33.88	H	Peak	48.24	-14.65	33.59	40.00	-6.41	E
65.89	H	Peak	49.18	-15.09	34.09	40.00	-5.91	E

Remark :

- (1) Measuring frequencies from 25 MHz to the 1GHz °
- (2) Radiated emissions measured in frequency range from 25 MHz to 1000MHz were made with an instrument using Peak detector mode.
- (3) "F" denotes fundamental frequency; "H" denotes spurious frequency. "E" denotes band edge frequency.
- (4) Data of measurement within this frequency range shown "--" in the table above means the reading of emissions are attenuated more than 20dB below the permissible limits or the field strength is too small to be measured.
- (5) The IF bandwidth of SPA between 25MHz to 30MHz was 10KHz; 30MHz to 1GHz was 100KHz.

This document is issued by the Company subject to its General Conditions of Service printed overleaf or available on request and accessible at www.sgs.com. Attention is drawn to the limitations of liability, indemnification, and Jurisdictional issued defined therein. Unless otherwise stated, the results shown in this test report refer only to the sample(s) tested. This document cannot be reproduced except in full, without prior approval of Company. Any unauthorized alteration, forgery or falsification of the content or appearance of this report is unlawful and offenders may be prosecuted to the fullest extent of the law. 此報告是遵循本公司訂定之通用服務條款所製作發放，請注意此條款列印於背面，亦可在www.sgs.com中查閱。將本公司之義務，免責，管轄權皆明確規範之。除非另有說明，此報告結果僅對檢驗之樣品負責。本報告未經本公司書面許可，不可部份複製。對本報告內容或外觀之任何未經授權之變更、偽造、竄改皆屬非法，違犯者將會被依法追訴。

7. Occupied Bandwidth

7.1 Measurement Procedure

1. The EUT was placed on a turn table which is 0.8m above ground plane.
2. Set EUT as normal operation
3. Set SPA Center Frequency = fundamental frequency, RBW, VBW= 10kHz, Span =100kHz.
4. Set SPA Max hold. Mark peak, -26dB.

7.2 Test SET-UP (Block Diagram of Configuration)

Same as 4.2 Radiated Emission Measurement.

7.3 Measurement Equipment Used:

Same as 4.2 Radiated Emission Measurement.

7.4 Measurement Results

26dB bandwidth = 42.054 kHz

Refer to attached data chart.

26dB Band Width Test Data

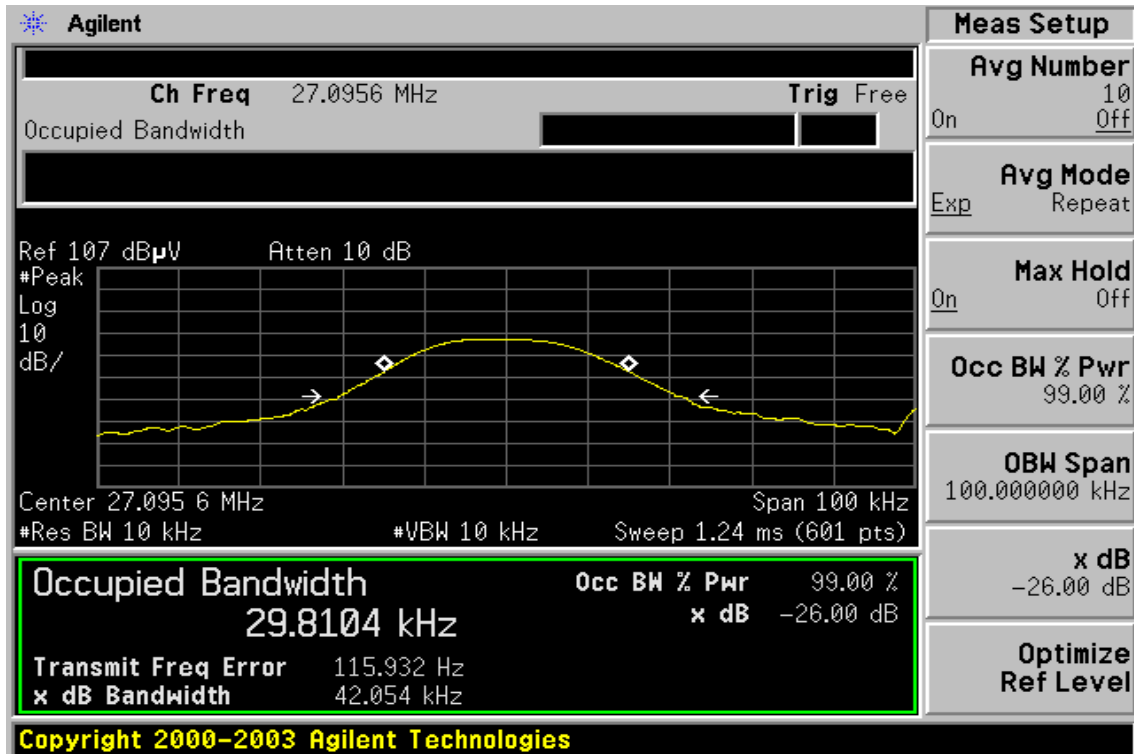

This document is issued by the Company subject to its General Conditions of Service printed overleaf or available on request and accessible at www.sgs.com. Attention is drawn to the limitations of liability, indemnification, and Jurisdictional issued defined therein. Unless otherwise stated, the results shown in this test report refer only to the sample(s) tested. This document cannot be reproduced except in full, without prior approval of Company. Any unauthorized alteration, forgery or falsification of the content or appearance of this report is unlawful and offenders may be prosecuted to the fullest extent of the law. 此報告是遵循本公司訂定之通用服務條款所製作發放，請注意此條款列印於背面，亦可在www.sgs.com中查閱。將本公司之義務，免責，管轄權皆明確規範之。除非另有說明，此報告結果僅對檢驗之樣品負責。本報告未經本公司書面許可，不可部份複製。對本報告內容或外觀之任何未經授權之變更、偽造、竄改皆屬非法，違犯者將會被依法追訴。