

FCC TEST REPORT

for

47 CFR, Part 15, Subpart C

Equipment : WIRELESS OFFICE MOUSE
Model No. : MCK-9000, MCK-9100, MCK-9200
FCC ID : GM8PROM910JOR1001
Filing Type : Certification
Applicant : **ORtek Technology, Inc.**
13F, NO. 150, JIAN YI RD. CHUNG HO CITY, TAIPEI
HSIEN, TAIWAN, R.O.C.

- The test result refers exclusively to the test presented test model / sample.
- Without written approval of SPORTON International Inc., the test report shall not be reproduced except in full.
- **Certificate or Test Report must not be used by the applicant to claim the product in this test report endorsement by NVLAP or any agency of U.S. government.**

SPORTON International Inc.

6F, No.106, Sec. 1, Hsin Tai Wu Rd., Hsi Chih, Taipei Hsien, Taiwan, R.O.C.

Table of Contents

History of this test report	ii
CERTIFICATE OF COMPLIANCE.....	1
1. General Description of Equipment under Test	2
1.1. Applicant.....	2
1.2. Manufacturer.....	2
1.3. Basic Description of Equipment under Test.....	2
1.4. Feature of Equipment under Test.....	3
2. Test Configuration of Equipment under Test	4
2.1. Test Manner	4
2.2. Description of Test System.....	4
2.3. Band edge compliance plot per 15.227(b).....	6
Vertical.....	6
2.4. Connection Diagram of Test System.....	7
3. General Information of Test	8
3.1. Test Facility	8
3.2. Test Voltage.....	8
3.3. Standard for Methods of Measurement.....	8
3.4. Test in Compliance with.....	8
3.5. Frequency Range Investigated.....	8
3.6. Test Distance.....	8
4. Test of Conducted Powerline.....	9
5. Test of Radiated Emission	10
5.1. Major Measuring Instruments.....	10
5.2. Test Procedures	11
5.3. Typical Test Setup Layout of Radiated Emission	12
5.4. Test Result of Radiated Emission	13
6. EMI Suppression Component List.....	14
7. Antenna Factor & Cable Loss	15
8. List of Measuring Equipments Used.....	16
9. Uncertainty of Test Site.....	17

CERTIFICATE OF COMPLIANCE

for

47 CFR, Part 15, Subpart C

Equipment : WIRELESS OFFICE MOUSE
Model No. : MCK-9000, MCK-9100, MCK-9200
FCC ID : GM8PROM910JOR1001
Filing Type : Certification
Applicant : **ORtek Technology, Inc.**
13F, NO. 150, JIAN YI RD. CHUNG HO CITY, TAIPEI
HSIEN, TAIWAN, R.O.C.

I **HEREBY** CERTIFY THAT :

The measurements shown in this test report were made in accordance with the procedures given in **ANSI C63.4 - 1992** and the energy emitted by this equipment was **passed** both radiated and conducted emission limits. Testing was carried out on Nov. 26, 2002 at **SPORTON International Inc.** LAB. in Lin Kou.

 Feb. 07, 2003

K. J. Lin
Manager

SPORTON International Inc.

6F, No.106, Sec. 1, Hsin Tai Wu Rd., Hsi Chih, Taipei Hsien, Taiwan, R.O.C.

1. General Description of Equipment under Test

1.1. Applicant

ORtek Technology, Inc.
13F, NO. 150, JIAN YI RD. CHUNG HO CITY,
TAIPEI HSIEN, TAIWAN, R.O.C.

1.2. Manufacturer

ORtek Technology, Inc.
4F, 1, LANE 125, JIAN BA RD, CHUNG HO CITY,
TAIPEI HSIEN, TAIWAN, R.O.C.

1.3. Basic Description of Equipment under Test

Equipment : WIRELESS OFFICE MOUSE
Model No. : MCK-9000, MCK -9100, MCK -9200
(these three models are identical product, the only difference is the model no.)
FCC ID : GM8PROM910JOR1001
Trade Name : ORtek Technology, Inc.
Power Supply Type : From Battery (3V)
Power Cord : N/A

1.4. Feature of Equipment under Test

OPERATION FREQUENCY	27.195 MHZ / 27.045 MHZ
TRANSMISSION DISTANCE	1M
MODULATION	FSK
BATTERY TYPE	2 * AA BATTERY
BATTERY LIFE	1.5 MONTH
CHANNEL	2 CHANNEL
POWER CONSUMPTION (WORKING)	40mA (TYPICAL)
POWER CONSUMPTION (SUSPEND)	<350uA
RESOLUTION	400 DPI
STORAGE TEMPERATURE	-15 ~ +85 C
WORKING TEMPERATURE	-10 ~ +60 C

2. Test Configuration of Equipment under Test

2.1. Test Manner

- a. The EUT has been configured and operated pursuant to ANSI C63.4-1992 in a manner which tended to maximize its emission characteristics in a typical application.
- b. Frequency range investigated: conduction 150 KHz to 30 MHz, radiation 30 MHz to 1000MHz.
- c. The complete test included HP PC, HITACHI Monitor, ORtek Technology RF Keyboard, ORtek Technology RF Receiver, HP Printer, ACEEX Modem and EUT for EMI test.

2.2. Description of Test System

Support Unit 1. -- Monitor (HITA CHI)

FCC ID	: N/A
Model No.	: CM823F
Power Supply Type	: Switching
Power Cord	: Non-Shielded
Serial No.	: SP0013
Data Cable	: Shielded, 360 degree via metal backshells, 1.7m
Remark	: This support device was tested to comply with FCC standards and authorized under a declaration of conformity.

Support Unit 2. -- Printer (HP)

FCC ID	: B94C2642X
Model No.	: DJ 400
Power Supply Type	: Linear
Power Cord	: Non-Shielded
Serial No.	: SP0014
Data Cable	: Shielded, 360 degree via metal backshells, 1.35m

Support Unit 3. -- Modem (ACEEX)

FCC ID	: IFAXDM1414
Model No.	: DM1414
Power Supply Type	: Linear
Power Cord	: Non-Shielded
Serial No.	: SP0015
Data Cable	: Shielded, 1.15m

Support Unit 4. -- Personal Computer (HP)

FCC ID : N/A
Model No. : DTPC-22
Power Supply Type : Switching
Power Cord : Non-Shielded
Serial No. : SP0039
Data Cable : Shielded, 360 degree via metal backshells
Remark : This support device was tested to comply with FCC standards and authorized under a declaration of conformity.

Support Unit 5. – RF Receiver (ORtek Technology)

FCC ID : N/A
Model No. : MCK-9200
Serial No. : SP0087

Support Unit 6. – RF Keyboard (ORtek Technology)

FCC ID : GM8LAB-22291001-00
Model No. : MCK-9000
Serial No. : SP0088

2.3. Band edge compliance plot per 15.227(b).

Vertical

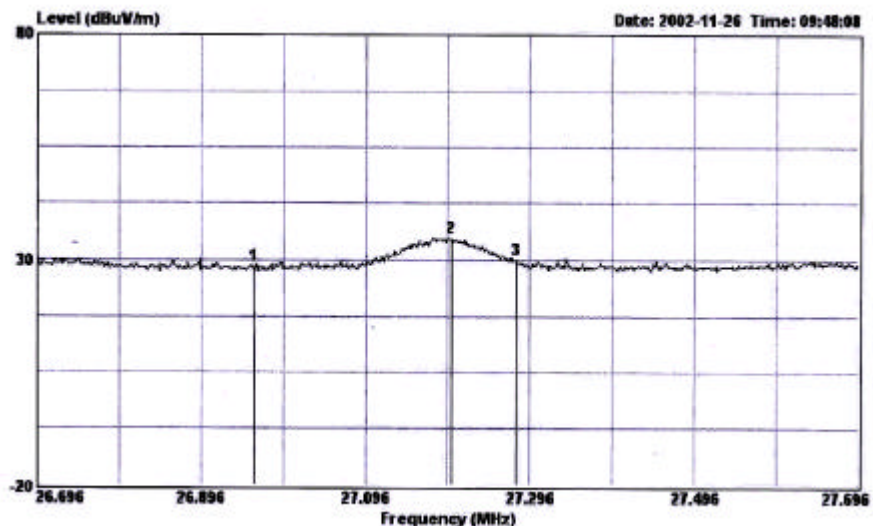

Mark 1 : 26.960MHz 14.59dBuV/m
 Mark 2 : 27.200MHz 20.81dBuV/m
 Mark 3 : 27.280MHz 15.91dBuV/m

Horizontal

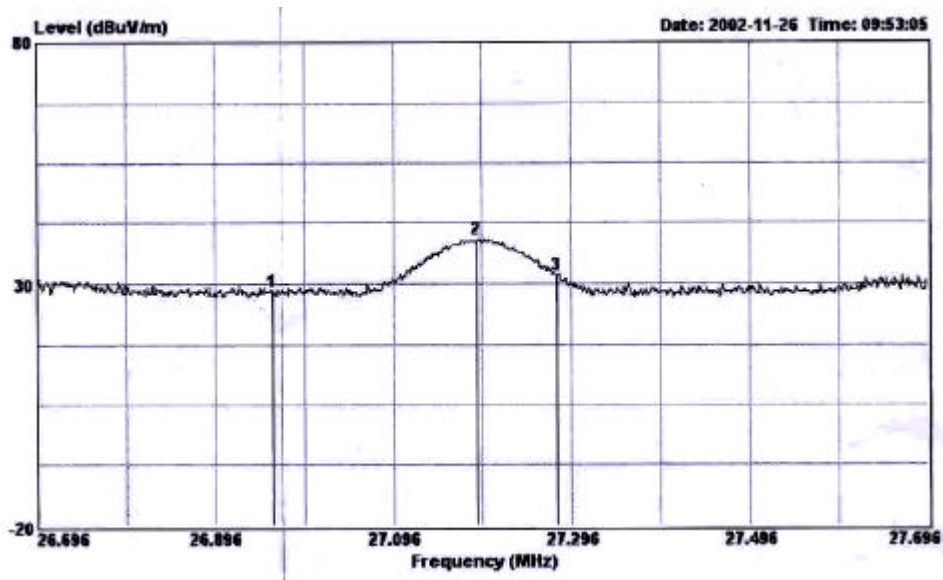

Mark 1 : 26.960MHz 14.35dBuV/m
 Mark 2 : 27.190MHz 25.11dBuV/m
 Mark 3 : 27.280MHz 17.49dBuV/m

RBW:120KHz,VBW:300KHz

Conformation of the fundamental frequency

2.4. Connection Diagram of Test System

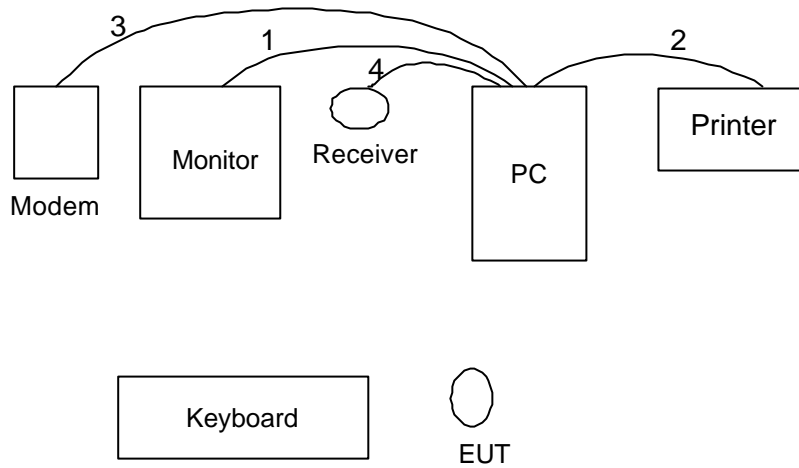

1. The I/O cable is connected from PC to the support unit 1.
2. The I/O cable is connected from PC to the support unit 2
3. The I/O cable is connected from PC to the support unit 3.
4. The I/O cable is connected from PC to the support unit 4.

3. General Information of Test

3.1. Test Facility

This test was carried out by SPORTON International Inc.

Test Site Location : No. 30-2, Lin 6, Diing-Fwu Tsuen, Lin-Kou-Hsiang,
Taipei Hsien, Taiwan, R.O.C.

TEL : 886-2-2601-1640

FAX : 886-2-2601-1695

Test Site No : 03CH03-HY

3.2. Test Voltage

115V/60Hz

3.3. Standard for Methods of Measurement

ANSI C63.4-1992

3.4. Test in Compliance with

FCC Part 15, Subpart C

3.5. Frequency Range Investigated

a. Radiation : from 30 MHz to 1 GHz

3.6. Test Distance

The test distance of radiated emission from antenna to EUT is 3 M.

4. Test of Conducted Powerline

The power supply of the EUT is from battery.

So the conducted powerline test is not applicable to the EUT.

5. Test of Radiated Emission

Radiated emissions from 30 MHz to 1 GHz were measured with a bandwidth of 120 kHz according to the methods defines in ANSI C63.4-1992. The EUT was placed on a nonmetallic stand in the open-field site, 0.8 meter above the ground plane, as shown in section 5.3. The interface cables and equipment positions were varied within limits of reasonable applications to determine the positions producing maximum radiated emissions.

5.1. Major Measuring Instruments

- Amplifier (HP 8447D)
 - RF Gain 30 dB
 - Signal Input 100 KHz to 1.3 GHz

- Spectrum Analyzer (R&S FSP)
 - Attenuation 10 dB
 - Start Frequency 30 MHz
 - Stop Frequency 1000 MHz
 - Resolution Bandwidth 120 KHz
 - Signal Input 9 KHz to 7 GHz

5.2. Test Procedures

- a. The EUT was placed on a rotatable table top 0.8 meter above ground.
- b. The EUT was set 3 meters from the interference receiving antenna which was mounted on the top of a variable height antenna tower.
- c. The table was rotated 360 degrees to determine the position of the highest radiation.
- d. The antenna is a half wave dipole and its height is varied between one meter and four meters above ground to find the maximum value of the field strength both horizontal polarization and vertical polarization of the antenna are set to make the measurement.
- e. For each suspected emission the EUT was arranged to its worst case and then adjust the antenna tower (from 1 M to 4 M) and turn table (from 0 degree to 360 degrees) to find the maximum reading.
- f. Set the test-receiver system to Peak or CISPR quasi-peak Detect Function and specified bandwidth with Maximum Hold Mode.
- g. If the emission level of the EUT in peak mode was 3 dB lower than the limit specified, then testing will be stopped and peak values of EUT will be reported, otherwise, the emissions which do not have 3 dB margin will be repeated one by one using the quasi-peak method and reported.

5.3. Typical Test Setup Layout of Radiated Emission

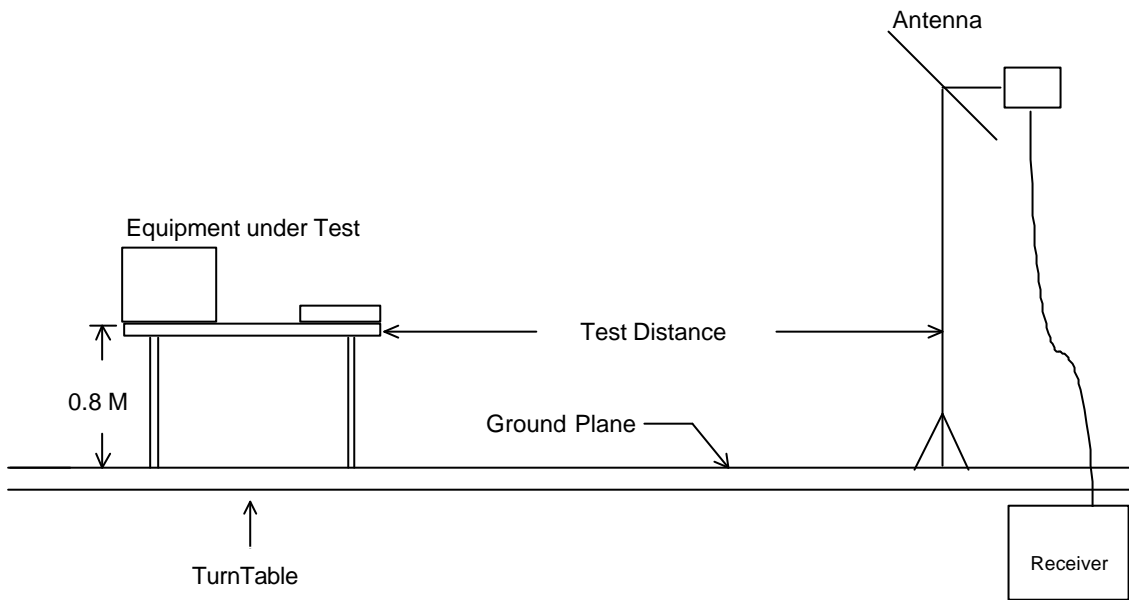

5.4. Test Result of Radiated Emission

- Test Distance : 3 M
- Temperature : 24°C
- Relative Humidity : 55 %
- Test Date : Nov. 25, 2002
- Emission level (dBuV/m) = 20 log Emission level (uV/m)
- Corrected Reading : Antenna Factor + Cable Loss + Reading = Emission

The Radiated Emission test was passed at minimum margin

36.210 MHz / 36.47 dBuV/m (HORIZONTAL) Antenna Height 3 Meter, Turntable Degree 185 °.

- Spurious Emissions:

Frequency (MHz)	Polarity	Antenna Factor (dB/m)	Cable Loss (dB)	Reading (dBuV)	Limits (dBuV/m)	(uV/m)	Emission Level (dBuV/m)	(uV/m)	Margin (dB)	Detect Mode
31.620	V	17.55	0.90	3.93	46.00	200	22.38	13.15	-23.62	Peak
62.940	V	5.04	1.37	8.91	40.00	100	15.32	5.83	-24.68	Peak
245.730	V	11.55	2.66	18.07	46.00	200	32.28	41.11	-13.72	Peak
36.210	H	15.01	0.96	20.50	40.00	100	36.47	66.60	-3.53	Peak
64.290	H	4.97	1.39	7.66	40.00	100	14.02	5.02	-25.98	Peak
90.210	H	8.67	1.60	12.32	43.50	150	22.59	13.47	-20.91	Peak

- Field strength of fundamental and harmonics

Frequency (MHz)	Polarity	Antenna Factor (dB/m)	Cable Loss (dB)	Reading (dBuV)	Limits (dBuV/m)	(uV/m)	Emission Level (dBuV/m)	(uV/m)	Margin (dB)	Detect Mode
27.200	V	0.93	15.40	4.48	80.00	10000	20.81	10.98	-59.19	Peak
27.190	H	0.93	15.40	8.78	80.00	10000	25.11	18.01	-54.89	Peak

Test Engineer : Jay
Jay Zhong

6. EMI Suppression Component List

⇒No EMI suppression components.

7. Antenna Factor & Cable Loss

Frequency (MHz)	Antenna Factor (dB)	Cable Loss (dB)
30	18.10	0.90
35	16.00	0.90
40	13.19	1.09
45	10.57	1.10
50	8.00	1.21
55	6.30	1.30
60	5.30	1.30
65	4.95	1.40
70	5.19	1.40
75	6.05	1.49
80	6.86	1.50
85	7.94	1.60
90	8.60	1.60
95	9.70	1.60
100	10.26	1.69
110	11.19	1.70
120	11.60	1.81
130	11.42	1.90
140	10.92	1.99
150	10.20	2.00
160	9.20	2.11
170	9.00	2.20
180	8.60	2.29
190	8.70	2.30
200	8.10	2.40
220	8.86	2.51
240	10.70	2.60
260	13.10	2.71
280	12.50	2.80
300	13.00	2.90
320	13.51	3.00
340	13.90	3.10
360	14.43	3.30
380	14.79	3.30
400	15.80	3.40
450	16.37	3.59
500	17.40	3.80
550	18.57	3.90
600	18.50	4.20
650	18.93	4.40
700	19.03	4.40
750	19.84	4.71
800	19.82	4.90
850	20.30	5.00
900	20.32	5.11
950	20.82	5.60
1000	21.20	5.50

8. List of Measuring Equipments Used

Instrument	Manufacturer	Model No.	Serial No.	Characteristics	Calibration Date	Remark
Spectrum Analyzer	R&S	FSP	838858/037	9KHz – 7GHz	Jan. 08, 2002	Radiation (03CH03-HY)
Amplifier	HP	8447D	2944A09072	100KHz – 1.3GHz	Oct. 21, 2002	Radiation (03CH03-HY)
Bilog Antenna	SCHAFFNER	CBL6112B	2687	30MHz –2GHz	Dec. 21, 2002	Radiation (03CH03-HY)
Turn Table	HD	DS 420	420/650/00	0 – 360 degree	N/A	Radiation (03CH03-HY)
Antenna Mast	HD	MA 240	240/560/00	1 m - 4 m	N/A	Radiation (03CH03-HY)
Half-wave dipole antenna	R&S	HZ12 HZ13	83924403 83924503	30MHz - 1GHz	Sep. 23, 2002	Radiation (03CH03-HY)
Loop Antenna	R&S	HFH2-Z2.335. 4711.52	860004/001	9KHz – 30MHz	Jun. 22, 2002	Radiation

Calibration Interval of instruments listed above is one year.

9. Uncertainty of Test Site

Uncertainty of Radiated Emission Measurement

Contribution	Probability Distribution	3m
Antenna factor calibration	normal(k=2)	±1
cable loss calibration	normal(k=2)	±0.3
RCV/SPA specification	rectangular	±2
Antenna Directivity	rectangular	±3
Antenna Factor V.S. Height	rectangular	±2
Antenna Factor Interpolation for Frequency	rectangular	±0.25
site imperfection	rectangular	±2
Mismatch Receiver VSWR $\Gamma_1=0.09$ Antenna VSWR $\Gamma_2=0.67$ Uncertainty= $20\log(1-\Gamma_1*\Gamma_2)$	U-shaped	±0.54
combined standard uncertainty Ue(y)	normal	±2.7
Measuring uncertainty for a level of confidence of 95% U=2Ue(y)	normal (k=2)	±5.4

$U = \{ (1/2)^2 + (0.3/2)^2 + (2^2 + 0.5^2 + 2^2 + 0.25^2 + 2^2) / 3 + (0.54)^2 / 2 \} = 2.2$ for 10m test distance

$U = \{ (1/2)^2 + (0.3/2)^2 + (2^2 + 3^2 + 2^2 + 0.25^2 + 2^2) / 3 + (0.54)^2 / 2 \} = 2.7$ for 3m test distance

Uncertainty of Conducted Emission Measurement

Contribution	Probability Distribution	150KHz – 30MHz
Cable and I/P attenuator calibration	normal(k=2)	±0.3
RCV/SPA specification	rectangular	±2
LISN coupling specification	rectangular	±1.5
Transducer factor frequency interpolation	rectangular	±0.2
Mismatch Receiver VSWR $\Gamma_1=0.09$ LISN VSWR $\Gamma_2=0.33$ Uncertainty= $20\log(1-\Gamma_1*\Gamma_2)$	U-shaped	0.2
combined standard uncertainty Ue(y)	normal	±1.66
Measuring uncertainty for a level of confidence of 95% U=2Ue(y)	normal (k=2)	±3.32

$U = \{ (0.3/2)^2 + (2^2 + 1.5^2 + 0.2^2) / 3 + (0.2)^2 / 2 \} = 1.66$