



R041-08-101420-4A - DM / CHB

RADIO TEST REPORT

According to the standard(s):

FCC part 15.247:2007

FCC part 22:2005

Equipment under test:

WORKABOUT PRO (7527C)
+ WA9005 + BT + RA2041 + RA3030
+ RFID Module HF-AM1-G2
FCC ID: GM3HFAM1G2

Company:

PSION TEKLOGIX

Diffusion: Mr PORTE

(Company: PSION TEKLOGIX)

Number of pages: 15 including 1 annex

Ed.	Date	Modified page(s)	Written by		Technical verification and Quality approval	
			Name	Visa	Name	Visa
3	11-Jun-08	10, 12 and 13	David MONTAULON		Régis GONZALEZ	

Duplication of this report is only permitted for an integral photographic facsimile. It includes the number of pages referenced above. This document is the result of testing a specimen or a sample of the product submitted. It does not imply an assessment of the conformity of the whole production of the item tested.



NAME OF THE EQUIPMENT UNDER TEST (E.U.T.) : WORKABOUT PRO (7527C) + WA9005 +
BT + RA2041 + RA3030 +
RFID Module HF-AM1-G2

Serial number : None

Part number : None

Software Version : None

MANUFACTURER'S NAME : PSION TEKLOGIX

APPLICANT'S ADDRESS:

Company : PSION TEKLOGIX

Address : 135 rue de la Duranne
BP 421000
13591 AIX EN PROVENCE CEDEX 3
FRANCE

Person(s) present during the tests : Mr PORTE

Responsible : Mr PORTE

DATE(S) OF TESTS : February, from 25th to 28th of 2008
May, 27th of 2008

TESTS LOCATION(S) : Emitech Grand Sud Laboratory in
Vendargues (34)
Open area test site in Salinelles (30)
FCC Registration number: 8127-19

TESTS SUPERVISOR(S) : None

TESTS OPERATOR(S) : David MONTAULON

CONTENTS

1. INTRODUCTION.....	4
2. REFERENCE DOCUMENT(S).....	4
3. EQUIPMENT UNDER TEST CONFIGURATION.....	4
4. EQUIPMENT UNDER TEST CONFIGURATION SCHEME.....	5
5. SUMMARY OF TEST RESULTS.....	6
6. RADIATED EMISSIONS - SECTION 15-247.....	7
7. ERP AND EIRP MEASUREMENT.....	10
8. FIELD STRENGTH OF SPURIOUS RADIATION (GSM850, GSM1900).....	12
ANNEX: PHOTOGRAPH(S).....	14

1. INTRODUCTION

This document submits the results of Electromagnetic Compatibility tests performed on the equipment WORKABOUT PRO (7527C) + WA9005 + BT + RA2041 + RA3030 + RFID Module HF-AM1-G2 (denominated hereafter E.U.T.: equipment under test) according to document(s) listed below.

Worst case configuration is used between WAP-C, WAP-S, antenna and with or without docking station.

2. REFERENCE DOCUMENT(S)

FCC Part 15 (February 2006)

Code of Federal Regulations
Title 47 – Telecommunications
Chapter 1 – Federal Communications Commission
Part 15 – Radio frequency devices
Subpart C – Intentional Radiators

ANSI C 63.4 (2003)

American National Standard for Methods of measurement of
Radio-Noise from low-voltage
Electrical and Electronic Equipment in the Range of 9 kHz to
40 GHz

FCC part 22:2005

Public Mobile Services
Subpart H: Cellular Radiotelephone Service

3. EQUIPMENT UNDER TEST CONFIGURATION

Product description:

FCC ID: GM3HFAM1G2

Utilization: RFID TAG reader

Antenna type: Incorporated antenna

Antenna gain: Unknown

Operating frequency range: 13.56 MHz (Rfid); 2402MHz (Bluetooth); 2437MHz (Wifi);
836.4MHz (GSM); 1860MHz (GSM)

Internal highest frequency: 2437MHz

Power source: 5 Vdc (stand alone) or mains voltage (with docking)

Power level and frequency range are not user adjustable

4. EQUIPMENT UNDER TEST CONFIGURATION SCHEME

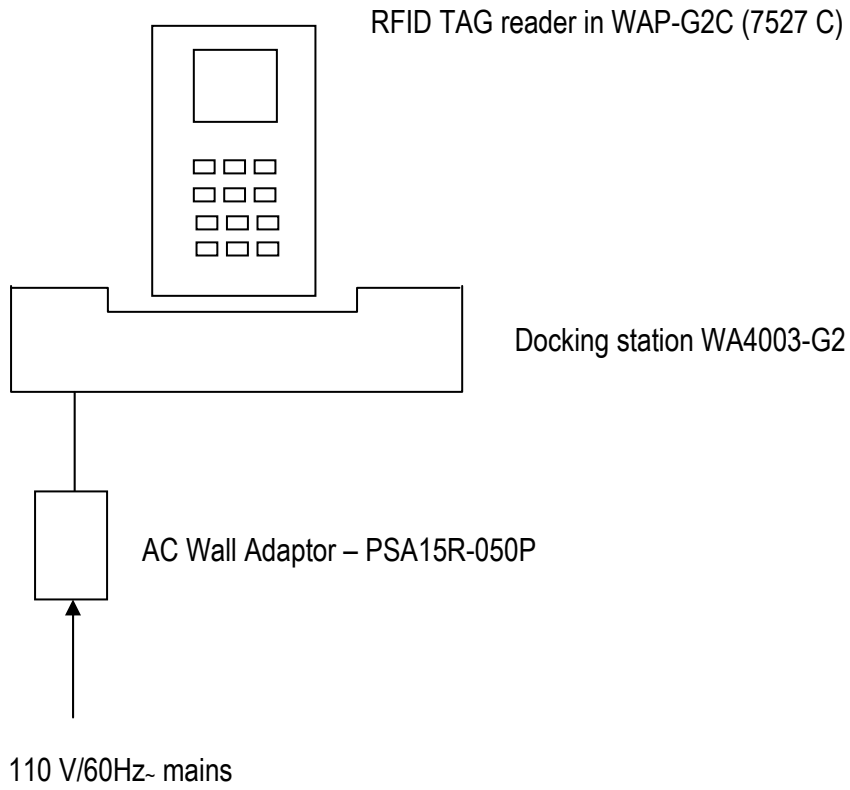

5. SUMMARY OF TEST RESULTS

Tests designation	Results satisfying?	Comments
Radiated emissions - section 15-247	YES	
ERP and EIRP measurement sections 22.913 and 22.917	YES	
Field strength of spurious radiation	YES	

N.P.: Not Performed.

N.A.: Not Applicable.

6. RADIATED EMISSIONS - SECTION 15-247
Radiated emissions (above 1GHz)

Standard: FCC part 15.247: 2007

Test method: ANSI C63.4:2003

Test configuration:

Frequency band	Configuration	Resolution bandwidth	Video bandwidth	Detection mode	E.U.T. height
1GHz-18GHz	Open area measurement	1MHz	1MHz	Peak	80cm

For each measured frequency, receiving antenna height varies between 1 m and 4 m, E.U.T. is set on a turntable in order to find the highest level.

E.U.T. internal functions are all active (GSM 850 or 1900, Wifi is active, Bluetooth is active, Rfid is active). GSM communication link is established via a CMU 200 (Rohde & Schwarz).

Test method deviation: Wifi and Bluetooth are in permanent emission, measurements are done in peak detection (worst case).

Measuring distance: 3 m

Test equipment list:

CATEGORY	BRAND	TYPE	N° EMITECH
Antenna	Emco	3115	1053
Cable			2717
Cable		N-6m	2840
Cable		N-17m	3620
Cable		N-8m	3694
Open area test site	Emitech	Salinelles	3482
Spectrum analyzer	Agilent Technologies	E7405A	2161

Results: See Board(s) hereafter

1) Wifi radiated field strength:

Frequency (MHz)	Polarization	Azimuth (degrees)	Antenna height (cm)	Peak Measure (dB μ V/m)	Standard limit (dB μ V/m)	Comments
2437.00	Vertical	168	134	100.28	125.2 (*)	C
2437.00	Horizontal	105	107	99.29	125.2 (*)	C

C= Compliant

NC= Not compliant

 2) Wifi radiated spurious:

Frequency (MHz)	Polar.	Azimuth (degrees)	Antenna height (cm)	Peak Measure (dB μ V/m)	Standard limit (dB μ V/m)	Average Value (dB μ V/m)	Standard limit (dB μ V/m)	Com.
4874.00	Vertical	250	100	56.89	74	41.05	54	C
4874.00	Horizontal	0	100	54.95	74	40.05	54	C
7311.00	Vertical	300	100	68.54	74	47.92	54	C
7311.00	Horizontal	0	100	60.38	74	46.92	54	C

 3) Bluetooth radiated field strength:

Frequency (MHz)	Polarization	Azimuth (degrees)	Antenna height (cm)	Measure (dB μ V/m)	Standard limit (dB μ V/m)	Comments
2402.00	Vertical	151	108	91.74	125.2 (*)	C
2402.00	Horizontal	135	100	88.48	125.2 (*)	C

(*) This limit is a theoretical conversion of standard limit given for 1W conducted power. E.U.T. antenna gain is less than 6dBi. Limit is reached by the following calculation:

$$E = \frac{\sqrt{30 \times P \times G}}{d}$$

with P in Watt (conducted power limit)
 G= 1 (dipole antenna theoretical gain)
 d= 3 m (test distance)
 E= Equivalent radiated electric field (V/m)

4) Bluetooth radiated spurious:

Frequency (MHz)	Polar.	Azimut (degrees)	Antenna height (cm)	Peak Measure (dB μ V/m)	Standard limit (dB μ V/m)	Average Value (**)(dB μ V/m)	Standard limit (dB μ V/m)	Com.
4804.00	Vertical	0	100	49.65	74	10.03	54	C
4804.00	Horizontal	0	100	49.65	74	10.03	54	C
7206.00	Vertical	0	100	61.10	74	21.48	54	C
7206.00	Horizontal	10	100	61.10	74	21.48	54	C

All other radiated emissions are more than 20 dB below the limit.

(**) According to test report concerning bluetooth part (report FR5D0903-03 from SPORTON International Inc) and section 15.247(a)(1)(iii) and 15.35(c), average time of occupation on any channel is 0.33s max in 79x0.4s = 31.6s

Then a correction factor can be used to calculate average value of the emission. This factor is $20 \times \log(0.33/31.6) = -39.62\text{dB}$

7. ERP AND EIRP MEASUREMENT

Standard: FCC part 22.913 and 22.917: 2005

Test method: ANSI C63.4:2003

Test configuration: Spurious emission level is measured by substitution method. Test are done in vertical and horizontal antenna polarization, E.U.T. is set on a turntable in order to find the highest level. Only highest levels are recorded.

Frequency band	Configuration	Resolution bandwidth	Video bandwidth	Detection mode	E.U.T. height
824-849MHz	Open area measurement	100kHz	300kHz	Peak	80cm
1850-1910MHz	Open area measurement	1MHz	3MHz	Peak	80cm

Ed.3

For each measured frequency, receiving antenna height varies between 1 m and 4 m, E.U.T. is set on a turntable in order to find the highest level.

E.U.T. internal functions are all active (GSM 850 or 1900, Wifi is active, Bluetooth is active, Rfid is active). GSM communication link is established via a CMU 200(Rohde & Schwarz).

Test method deviation: Wifi and Bluetooth are in permanent emission. Measurements are done in peak detection (worst case).

Measuring distance: 3 m

Test equipment list:

CATEGORY	BRAND	TYPE	N° EMITECH
Antenna	Emco	3115	1053
Antenna	Rohde & Schwarz	HL223	3126
Antenna	Schwarzbeck	UHA 9105	4660
Antenna	ETS LINDGREN	3117	5456
Cable			2717
Cable		N-6m	2840
Cable		N-17m	3620
Cable		N-8m	3694
Open area test site	Emitech	Salinelles	3482
Signal generator	Anritsu	MG3692A	3131
Spectrum analyzer	Agilent Technologies	E7405A	2161

Results: See Board(s) hereafter

1) GSM850 radiated field strength:

Frequency (MHz)	Polarization	Field strength (dBm)	Standard limit (dBm)	Comments
836.40	Vertical	28.84	38	C
836.40	Horizontal	22.70	38	C

C= Compliant

NC= Not compliant

1) GSM1900 radiated field strength:

Frequency (MHz)	Polarization	Field strength (dBm)	Standard limit (dBm)	Comments
1860.00	Vertical	17.87	33	C
1860.00	Horizontal	21.63	33	C

C= Compliant

NC= Not compliant

8. FIELD STRENGTH OF SPURIOUS RADIATION (GSM850, GSM1900)

Standard: FCC part 22 subpart H

Test method: ANSI C63.4:2003

Test configuration: Spurious emission level is measured by substitution method. Test are done in vertical and horizontal antenna polarization, E.U.T. is set on a turntable in order to find the highest level. Only highest levels are recorded.

Frequency band	Configuration	Resolution bandwidth	Video bandwidth	Detection mode	E.U.T. height
1GHz-18GHz	Open area measurement	1MHz	3MHz	Average	80cm
1GHz-18GHz (*)	Open area measurement	100kHz	300kHz	Average	80cm

(*) Remark: on some frequencies, measurement has been made with these resolution and video bandwidths because of too high background noise (see p13)

For each measured frequency, receiving antenna height varies between 1 m and 4 m, E.U.T. is set on a turntable in order to find the highest level.

E.U.T. internal functions are all active (GSM 850 or 1900, Wifi is active, Bluetooth is active, Rfid is active).

GSM communication link is established via a CMU 200 (Rohde & Schwarz).

Wifi and Bluetooth are in permanent emission.

Measurements are done in peak detection (worst case).

Test method deviation: No

Measuring distance: 3 m

Test equipment list:

CATEGORY	BRAND	TYPE	N° EMITECH
Antenna	Emco	3115	1053
Antenna	Rohde & Schwarz	HL223	3126
Antenna	Schwarzbeck	UHA 9105	4660
Antenna	ETS LINDGREN	3117	5456
Cable			2717
Cable		N-6m	2840
Cable		N-17m	3620
Cable		N-8m	3694
Open area test site	Emitech	Salinelles	3482
Signal generator	Anritsu	MG3692A	3131
Spectrum analyzer	Agilent Technologies	E7405A	2161

Results: See Board(s) hereafter

1) GSM850 spurious radiation:

Frequency (MHz)	Polarization	Field strength (dBm)	Standard limit (dBm)	Comments
1672.80	Vertical	-53.60	-13	C
1672.80	Horizontal	-55.45	-13	C
2509.20	Vertical	-54.13	-13	C
2509.20	Horizontal	-52.65	-13	C
3345.60	Vertical	-46.12	-13	C
3345.60	Horizontal	-48.12	-13	C
4182.00	Vertical	-47.72	-13	C
4182.00	Horizontal	-47.97	-13	C

C= Compliant

NC= Not compliant

1) GSM1900 spurious radiation:

Frequency (MHz)	Polarization	Field strength (dBm)	Standard limit (dBm)	Comments
3720.00(*)	Vertical	-29.82	-13	C
3720.00(*)	Horizontal	-21.09	-13	C
5580.00(*)	Vertical	-39.13	-13	C
5580.00(*)	Horizontal	-39.47	-13	C
7440.00(*)	Vertical	-33.44	-13	C
7440.00(*)	Horizontal	-32.53	-13	C

C= Compliant

NC= Not compliant

(*) : see remark on p12

Ed.3

All other radiated emissions are more than 20 dB below the limit.

□□□ End of report – 1 annex to be forwarded □□□

ANNEX: PHOTOGRAPH(S)

EQUIPEMENT UNDER TEST (E.U.T.) PHOTOGRAPH(S)

WORKABOUT PRO (7527C) + WA9005 + BT + RA2041 + RA3030 +
RFID Module HF-AM1-G2

Radiated electric field
emission on OATS

