



FCC
Test Report
for
Workabout Pro, ACG 13.56MHz RFID, Docking
Station and AC/DC Adaptor
7525

Report Number 03-559/2759/2/05A
Supersedes report number 03-559/2759/2/05
Report Produced by: -

R.N. Electronics Ltd.

1 Arnolds Court
Arnolds Farm Lane
Mountnessing
ESSEX
CM13 1UT

www.rnelectronics.com

Telephone 01277 352219
Facsimile 01277 352968

1. Contents

1.	CONTENTS	2
2.	SUMMARY OF TEST RESULTS	3
3.	INFORMATION ABOUT EQUIPMENT UNDER TEST	4
4.	SPECIFICATIONS	5
5.	TESTS, METHODS AND RESULTS	6
5.1	Conducted Emissions	6
5.2	Radiated Emissions.....	7
5.3	Intentional Radiator Field Strength	8
5.4	Frequency Tolerance	9
6.	PLOTS AND RESULTS	10
6.1	Conducted Emissions	10
6.2	Radiated Emissions.....	18
6.3	Fundamental Emissions	44
7.	EXPLANATORY NOTES	46
7.1	Explanation of FAIL LIMIT 1 Statement.....	46
7.2	Explanation of limit line calculations for radiated measurements	46
8.	PHOTOGRAPHS	47
9.	SIGNAL LEADS.....	52
10.	TEST EQUIPMENT CALIBRATION LIST	53
11.	AUXILIARY EQUIPMENT	54
11.1	Auxiliary equipment supplied by Psion Teklogix UK Ltd	54
11.2	Auxiliary equipment supplied by RN Electronics Limited.....	54
12.	MODIFICATIONS	55
13.	Compliance information.....	56

2. Summary of Test Results

The Workabout Pro, ACG 13.56MHz RFID, Docking Station and AC/DC Adaptor was tested to the following standards: -

FCC Part 15C (effective date March 11, 2005); Class DXX Intentional Radiator

Title	Reference	Results
1. Conducted Emissions	FCC Part 15C §15.207	PASSED
2. Radiated Emissions	FCC Part 15C §15.209	PASSED
3. Intentional Radiator Field Strength	§15.225 (a), (b), (c), (d)	PASSED
4. Frequency Tolerance	§15.225 (e)	PASSED

Date of Test: 11th - 15th March 2005

Test Engineer:

Approved By:

Customer Representative:

Steve Lucas

3. Information about Equipment Under Test

Manufacture of EUT Psion Teklogix UK Ltd
Unit Q, Bourne End Business Park
Cores End Road
Buckinghamshire
SL8 5AS

Full name of EUT **Workabout Pro with RFID Module**

Model Number of EUT 7525C
ACG 13.56MHz RFID, **HFAM1-A2**
Antenna PCB, **HF-A2**
ACG RFID PCB / interface PCB, **HFAM1**
Docking Station, **WA4002**
AC/DC Adaptor, **LSE9912B0515**

Serial Number of EUT 1247D025757
ACG 13.56MHz RFID, **270105CHM1020**
Antenna PCB, **270105AHA2020**
Docking Station, **1248D001868**
AC/DC Adaptor, **A30417059761**

FCC ID (if applicable): GM3HFAM1

Date when equipment was received by RN Electronics Limited 10th March 2005

Date of test: 11th - 15th March 2005

Customer order number: 108625

A visual description of EUT is as follows: The Workabout Pro 7525C is a colour portable PC and included an MMC & CF memory card. It also had a Lithium Ion polymer rechargeable battery pack, laser scanner unit (SE1223) and bluetooth module. The ACG RFID coupler consisted of an Antenna PCB and ACG RFID PCB / interface PCB. Supplied with the unit is a docking station and AC/DC adaptor

The main function of the EUT is: Handheld PC terminal with RFID module

Antenna: Integral

Equipment Under Test Information specification:

Height	220mm
Width	100mm
Depth	45mm
Weight	0.5kg
Voltage	110V ac / 3.9V battery
Current required from above voltage source	< 1 A
Highest Frequencies used / generated	Intentional Radiator 13.56MHz Digital Device 400MHz n.b. Bluetooth operational but not tested

Description of ancillary equipment connected to the equipment under test, for the purpose of tests, can be found in Section 11.

Any modifications made to the **EUT**, whilst under test, can be found in Section 12.

This report was printed on: 19 April 2005

4. Specifications

The tests were performed by RN Electronics Engineer Daniel Sims who set up the tests, the test equipment, and operated it in accordance with the **R.N. Electronics Ltd** procedures manual and FCC Part 15.

5. Tests, Methods and Results

5.1 Conducted Emissions

5.1.1 Test Methods

Test Requirements FCC Part 15C, Reference (15.207)

Test Method: FCC Part 15C, Reference (15.207)

5.1.1.1 Configuration of EUT

The EUT was connected to the LISN, and operated in the mode found to produce the highest emissions.

5.1.1.2 Test Procedure

Tests were made in accordance with FCC Part 15 using the measuring equipment noted in the 'Test Equipment' Section. The equipment under test was powered via a mains LISN with a mains lead of 1 metre. Any excess mains lead was placed in a 400mm bundle. At least 6 signals within 20dB and all signals within 10dB of the limit were investigated.

5.1.2 Test results

Tests were performed using Test Site F.

Temperature of test Environment: 20°C

Analyser plots for the Quasi-Peak Values and any table of signals within 10dB of the limit line can be found in Section 6.1 of this report.

Analyser plots for the Average values and any table of signals within 10dB of the limit line can be found in Section 6.1 of this report.

These results show that the **EUT** has **PASSED** this test.

5.1.2.1 Test Equipment used

E10, E226, E35, TMS912

See Section 10 for more details.

5.2 Radiated Emissions

5.2.1 Test Methods

Test Requirements FCC Part 15C, Reference (15.209)

Test Method: FCC Part 15C, Reference (15.209)

5.2.1.1 Configuration of EUT

The EUT was placed on a 0.8 metres high turntable. The front edge of the EUT was initially positioned facing the antenna. The EUT was measured at a distance of 3 metres. EUT was operated with RFID, Scanner and Bluetooth functions simultaneously. Tests were repeated with and without the docking cradle. Peripherals were connected to the docking cradle (mouse and USB).

5.2.1.2 Test Procedure

Tests were made in accordance with FCC Part 15 using the measuring equipment noted below.

Above 30MHz, measurements were made in a semi-anechoic chamber (pre-scan) with final measurements on an OATS. Test sites 'M' and 'OATS' have been listed with the FCC. The equipment was rotated 360° and the antenna scanned 1 – 4 metres in both horizontal and vertical polarisations to record the worst case emissions.

Below 30MHz, measurements were made in a semi-anechoic chamber (pre-scan) with final measurements on an OATS without a ground plane. The antenna was placed 1m above the ground. The equipment and the antenna were rotated 360° to record the worst case emissions.

At least 6 signals within 20dB and all signals within 10dB of the limit were investigated.

5.2.2 Test results

Tests were performed using Test Site **M, OATS**.

Test Environment:

M	Temperature: 21°C	Humidity: 48 %
OATS	Temperature: 6°C	Humidity: 42 %

Analyser plots for the Quasi-Peak / Average values as applicable and any table of signals within 10dB of the limit line can be found in Section 6.2 of this report.

These show that the **EUT** has **PASSED** this test.

5.2.2.1 Test Equipment used

E226, TMS81, E131, TMS814, TMS815, TMS933, TMS907, E136, E3, TMS82

See Section 10 for more details

5.3 Intentional Radiator Field Strength

5.3.1 Test Methods

Test Requirements	FCC Part 15C, Reference (15.225)
Test Method:	FCC Part 15C, Reference (15.215)

5.3.1.1 Configuration of EUT

The EUT was placed on a 0.8 metres high turntable. The front edge of the EUT was initially positioned facing the antenna. The EUT was measured at a distance of 3 metres. The antenna was placed 1m above the ground.

EUT was operated with RFID, Scanner and Bluetooth functions simultaneously. Tests were repeated with and without the docking cradle. Peripherals were connected to the docking cradle (mouse and USB).

5.3.1.2 Test Procedure

Tests were made in accordance with FCC Part 15 using the measuring equipment noted below.

Measurements were made in a semi-anechoic chamber and repeated on an OATS.

Both the equipment and the antenna were rotated 360° record the maximised emission.

5.3.2 Test results

Tests were performed using Test Site **M, OATS**.

Test Environment:

M	Temperature: 21°C	Humidity: 48 %
OATS	Temperature: 6°C	Humidity: 42 %

Results are presented graphically in section 6.

An extrapolation factor of 40dB / decade is used. E.g. limit of 15484 $\mu\text{V/m}$ is converted to 84 dB $\mu\text{V/m}$ [20Log(15848)] and because it is measured at 3m instead of 30m the limit is raised 40dB to 124 dB $\mu\text{V/m}$.

These show that the EUT has **PASSED** this test.

5.3.2.1 Test Equipment used

E226, TMS903, TMS907

See Section 10 for more details

5.4 Frequency Tolerance

5.4.1 Test Methods

Test Requirements	FCC Part 15C, Reference (15.225)
Test Method:	FCC Part 15C, Reference (15.225)

5.4.1.1 Configuration of EUT

The EUT was placed in a temperature controlled chamber. The EUT emissions were observed by means of an inductive loop test fixture. Tests were repeated with and without the docking cradle.

5.4.1.2 Test Procedure

Tests were made in accordance with FCC Part 15 using the measuring equipment noted below.

Temperature stability was achieved at each test level before taking measurements.

5.4.2 Test results

Tests were performed using Test Site A.

Test Environment:

Temperature: 22 °C

Relative humidity: 33%

Output Power	0.25W
Channel Spacing	single channel
Modulation	OOK / ASK

Test Conditions		Frequency Reading (MHz)	
Temperature (°C)	Voltage	Docked	Handheld
+50	nominal	13.559241	13.559658
+40	nominal	13.559303	13.559650
+30	nominal	13.559328	13.559508
+20	maximum	13.559703	-
+20	nominal	13.559453	13.559503
+20	minimum	13.559663	-
+10	nominal	13.559466	13.559750
0	nominal	13.559391	13.559800
-10	nominal	13.559391	13.559838
-20	nominal	13.559740	13.559763
Maximum Frequency Error observed	(Hz)	-759	-497
	(%)	0.006	0.004

These results show that the EUT has **PASSED** this test.

5.4.2.1 Test Equipment used

E3, TMS32, TMS38, TMS73, TMS80
See Section 10 for more details

6. Plots and Results
6.1 Conducted Emissions



11:11:14 JUL 23, 2003 15:16:15 APR 15, 2004
ACTV DET: PEAK
MEAS DET: PEAK QP

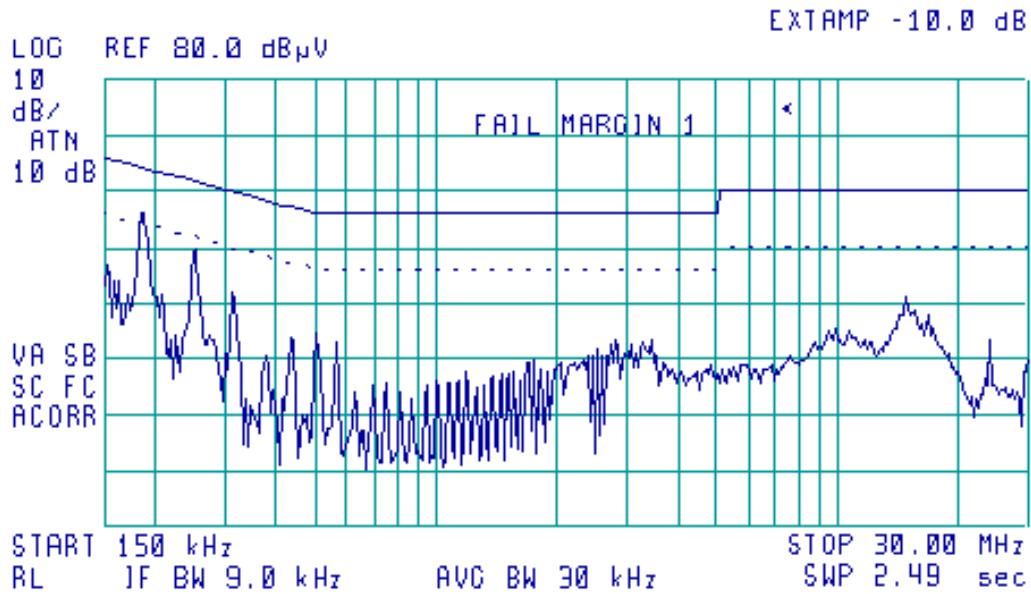

Quasi-peak values of mains live feed

The plot shows a swept response of peak values using the quasi-peak limit line

(Any peaks within 10dB of the limit line have been calculated and appear in the table on following page of this report)

Table of signals within 10dB of the limit line for Quasi-Peak Live

Signal	Freq (MHz)	Peak Amp (dBuV)	Peak - Lim1 (dB)	QP Amp (dBuV)	QP - Lim1 (dB)	
1	0.19104	6	56.64	-7.36	55.27	-8.73

Measurement Uncertainty of ± 3.6 dB Applies



11:11:14 JUL 23, 2003 15:16:15 APR 15, 2004

ACTV DET: PEAK
MEAS DET: PEAK QP

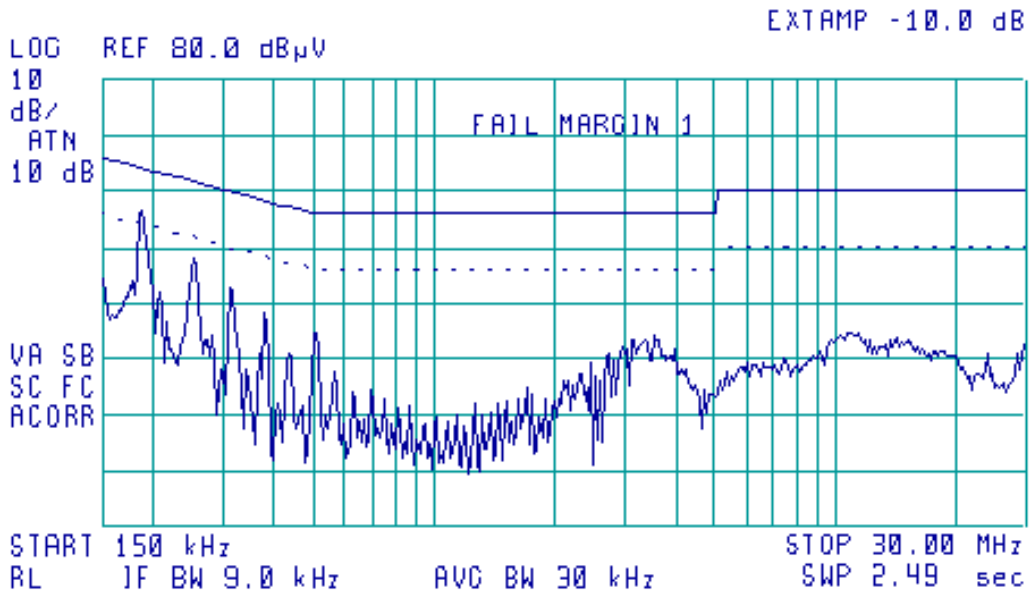

Quasi-peak values of mains neutral feed

The plot shows a swept response of peak values using the quasi-peak limit line

(Any peaks within 10dB of the limit line have been calculated and appear in the table on following page of this report)

Table of signals within 10dB of the limit line for Quasi-peak Neutral

Signal	Freq (MHz)	Peak Amp (dBuV)	Peak - Lim1 (dB)	QP Amp (dBuV)	QP - Lim1 (dB)
	0.19025				
1	5	56.73	-7.31	55.65	-8.39
	0.19073				
2	8	57.05	-6.96	55.85	-8.16

Measurement Uncertainty of ± 3.6 dB Applies



11:11:14 JUL 23, 2003 11:13:07 JUL 23, 2003
ACTV DET: PEAK
MEAS DET: PEAK AVC

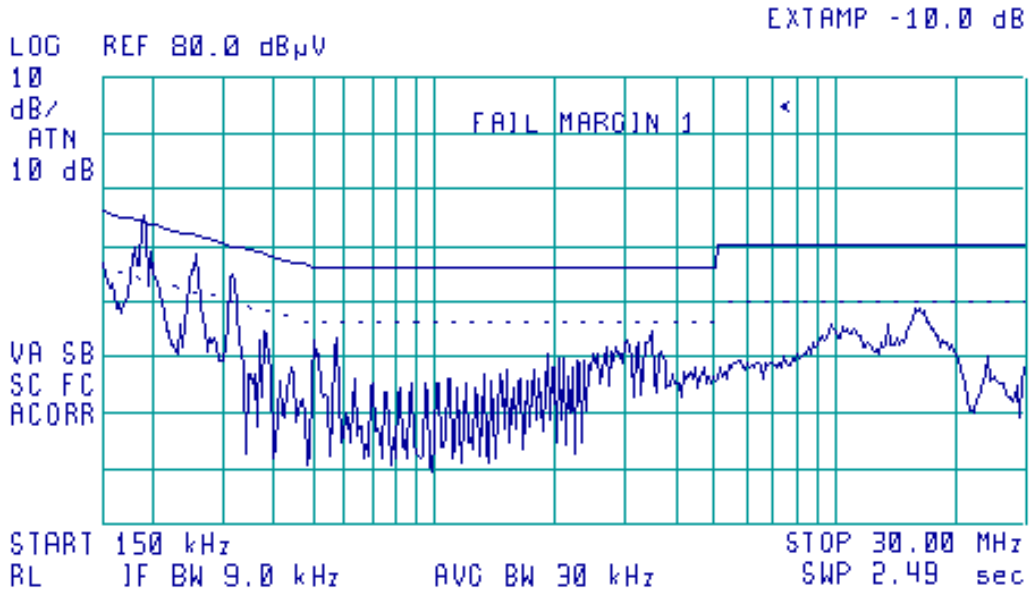

Average values of mains live feed

The plot shows a swept response of peak values using the average limit line

(Any peaks within 10dB of the limit line have been calculated and appear in the table on following page of this report)

Table of signals within 10dB of the limit line for Average Live

Signal	Freq (MHz)	Peak Amp (dBuV)	Peak - Lim1 (dB)	Avg Amp (dBuV)	Avg - Lim1 (dB)
	0.19185				
1	8	57.69	3.72	48.06	-5.91
	0.19208				
2	1	57.67	3.71	47.92	-6.04
3	0.25596	50.63	-0.98	44.28	-7.33
	0.25596				
4	4	50.99	-0.62	44.26	-7.35
5	0.31942	45.44	-4.31	37.59	-12.16

Measurement Uncertainty of ± 3.6 dB Applies



11:11:14 JUL 23, 2003 11:13:07 JUL 23, 2003

ACTV DET: PEAK
MEAS DET: PEAK AVC
MKR 1.64 MHz
24.27 dBμV
EXTAMP -10.0 dB

LOG REF 80.0 dBμV

10
dB/
ATN
10 dB

VA SB
SC FC
ACORR

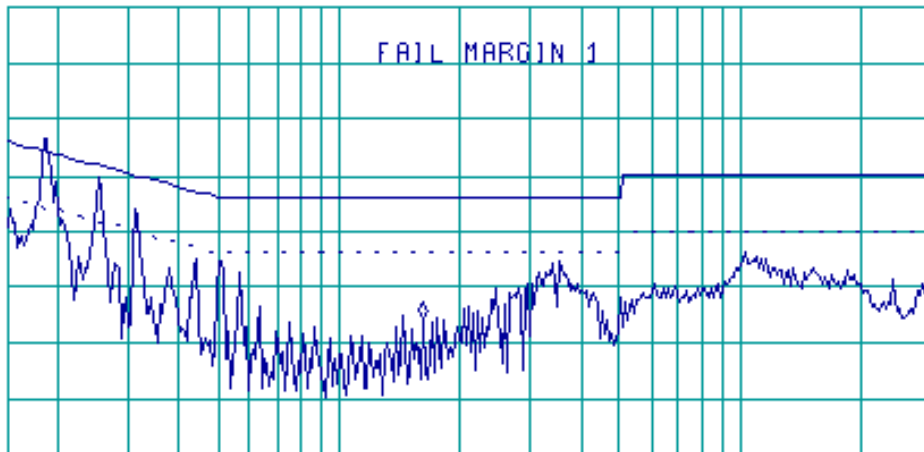

START 150 kHz STOP 30.00 MHz
RL 1F BW 9.0 kHz AVC BW 30 kHz SWP 2.49 sec

Average values of mains neutral feed

The plot shows a swept response of peak values using the average limit line

(Any peaks within 10dB of the limit line have been calculated and appear in the table on following page of this report)

Table of signals within 10dB of the limit line for Average Neutral

Signal	Freq (MHz)	Peak Amp (dBuV)	Peak - Lim1 (dB)	Avg Amp (dBuV)	Avg - Lim1 (dB)
1	0.19144 0.19145	57.45	3.47	47.61	-6.37
2	9 0.19178	57.53	3.55	47.82	-6.16
3	9 0.25486	57.61	3.64	47.79	-6.18
4	9 0.25532	50.67	-0.97	44.27	-7.37
5	5 0.31818	50.74	-0.89	44.21	-7.42
6	3	44.35	-5.43	35.92	-13.86

Measurement Uncertainty of ± 3.6 dB Applies

6.2 Radiated Emissions

6.2.1 Handheld



11:45:03 JUL 25, 2003 12:28:17 SEP 11, 2003

ACTV DET: PEAK
MEAS DET: PEAK QP

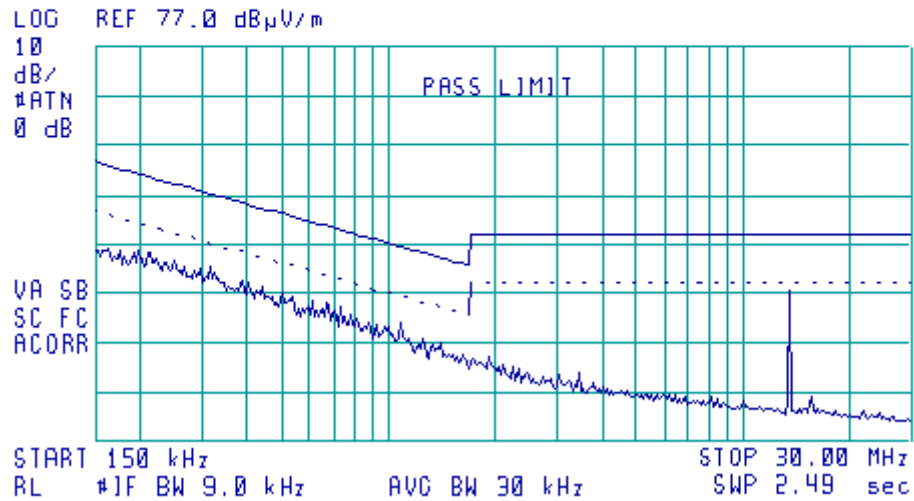

Quasi-Peak Values 490kHz to 30MHz.

The plot shows a swept response of peak values using the quasi-peak limit line



11:45:03 JUL 25, 2003 12:35:11 JAN 29, 2004

ACTV DET: PEAK
MEAS DET: PEAK QP

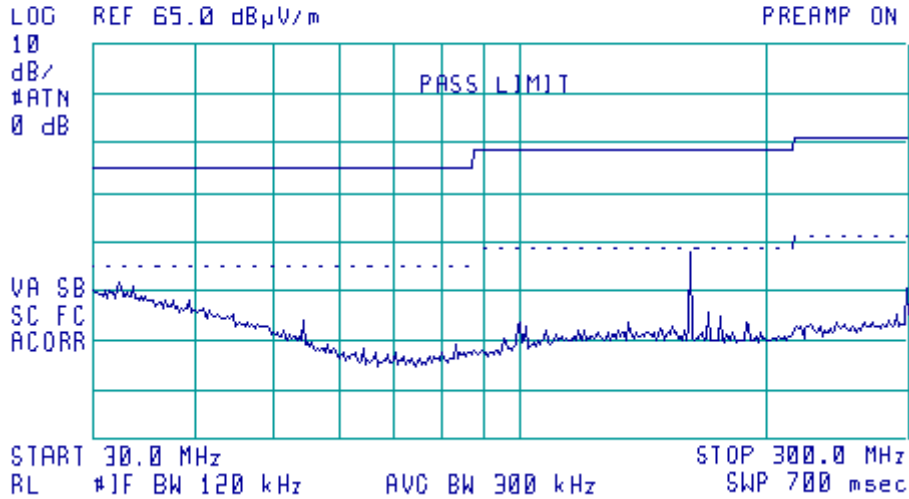

Quasi-Peak Values of 30 MHz. to 300 MHz. Horizontal Polarisation

The plot shows a swept response of peak values using the quasi-peak limit line

(Any peaks within 20dB of the limit line have been calculated and appear in the table on following page of this report)

Table of signals within 20dB of the limit line for Quasi-Peak Horizontal

None

Measurement Uncertainty of ± 5.2 dB Applies



11:45:03 JUL 25, 2003 12:35:11 JAN 29, 2004

ACTV DET: PEAK
MEAS DET: PEAK QP

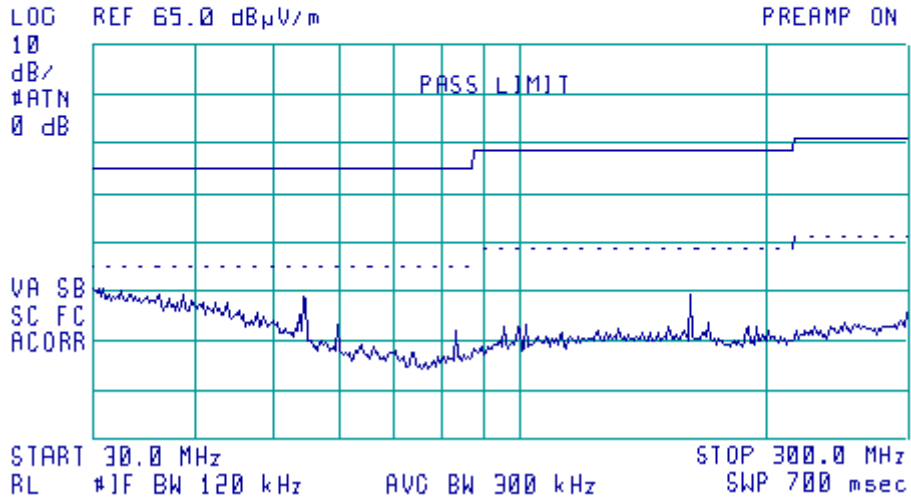

Quasi-Peak Values of 30 MHz. to 300 MHz. Vertical Polarisation

The plot shows a swept response of peak values using the quasi-peak limit line

(Any peaks within 20dB of the limit line have been calculated and appear in the table on following page of this report)

Table of signals within 20dB of the limit line for Quasi-peak Vertical

NONE

Measurement Uncertainty of ± 5.2 dB Applies



11:45:03 JUL 25, 2003 12:35:11 JAN 29, 2004

ACTV DET: PEAK
MEAS DET: PEAK QP

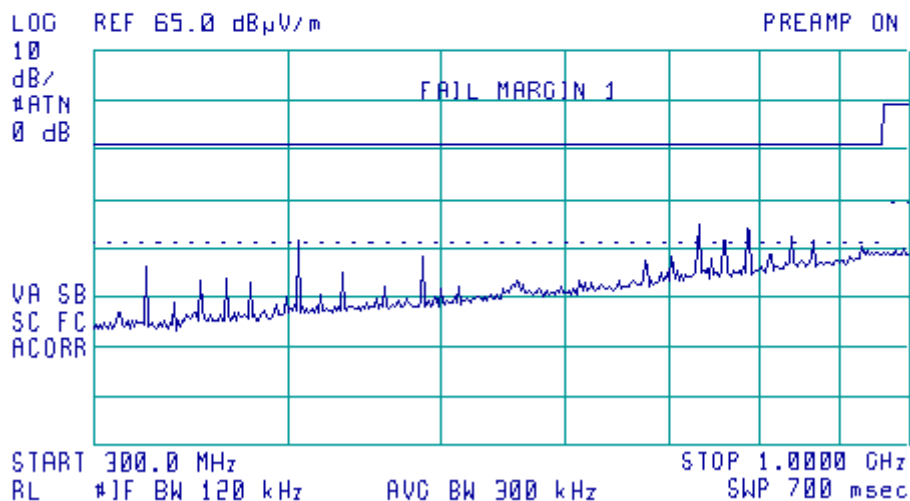

Quasi-Peak Values of 300 MHz. to 1 GHz. Horizontal Polarisation

The plot shows a swept response of peak values using the quasi-peak limit line

(Any peaks within 20dB of the limit line have been calculated and appear in the table on following page of this report)

Table of signals within 20dB of the limit line for Quasi-Peak Horizontal

Signal	Freq (MHz)	Peak Amp (dBuV/m)	Peak - Lim1 (dB)	QP Amp (dBuV/m)	QP - Lim1 (dB)
1	406.774	24.33	-21.67	21.83	-24.17
	732.209				
2	9	28.56	-17.44	25.71	-20.29
	759.305				
3	8	26.36	-19.64	22.71	-23.29
	786.440				
4	9	28.83	-17.17	26.16	-19.84
	840.698				
5	1	27.88	-18.12	24.73	-21.27
	867.818				
6	7	27.2	-18.8	23.17	-22.83

Measurement Uncertainty of ± 5.2 dB Applies



11:45:03 JUL 25, 2003 12:35:11 JAN 29, 2004

ACTV DET: PEAK
MEAS DET: PEAK QP

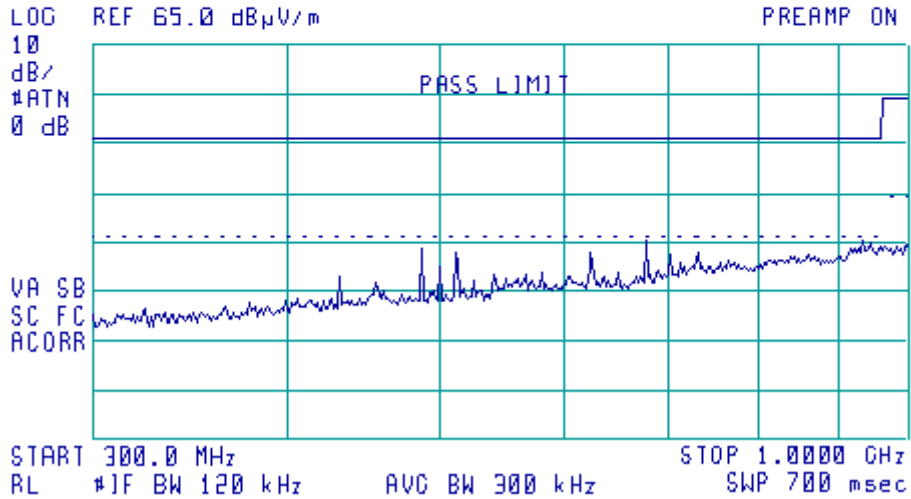

Quasi-Peak Values of 300 MHz. to 1 GHz. Vertical Polarisation

The plot shows a swept response of peak values using the quasi-peak limit line

(Any peaks within 20dB of the limit line have been calculated and appear in the table on following page of this report)

Table of signals within 20dB of the limit line for Quasi-peak Vertical

NONE

Measurement Uncertainty of ± 5.2 dB Applies

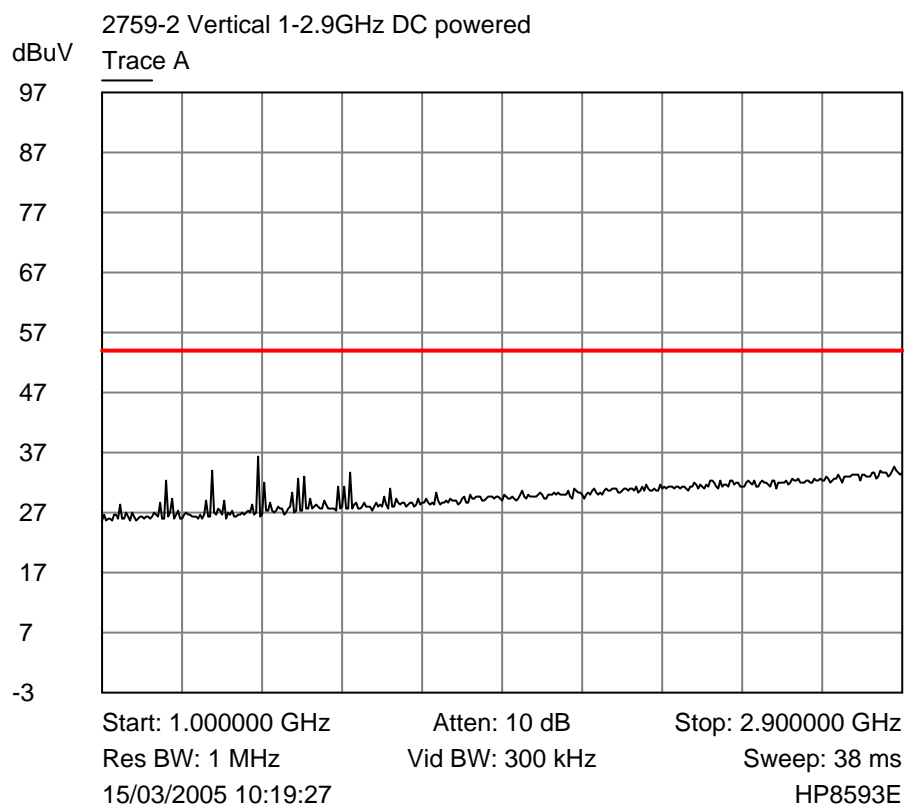

Average Values of 1 to 2.9GHz. Vertical Polarisation

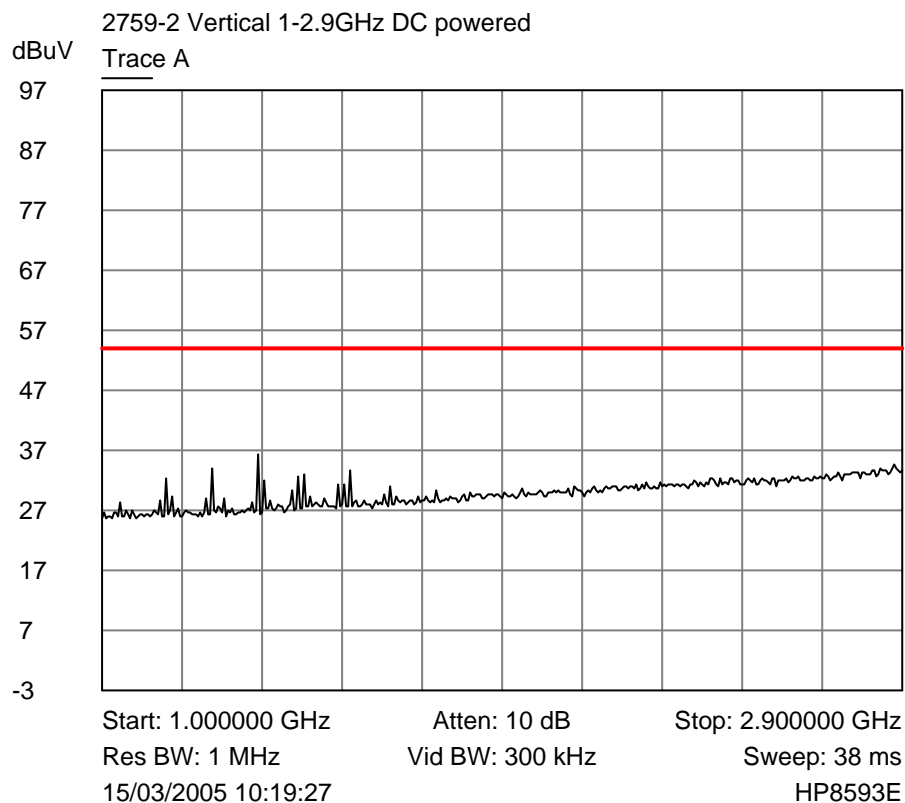

Average Values of 1 to 2.9GHz. Horizontal Polarisation

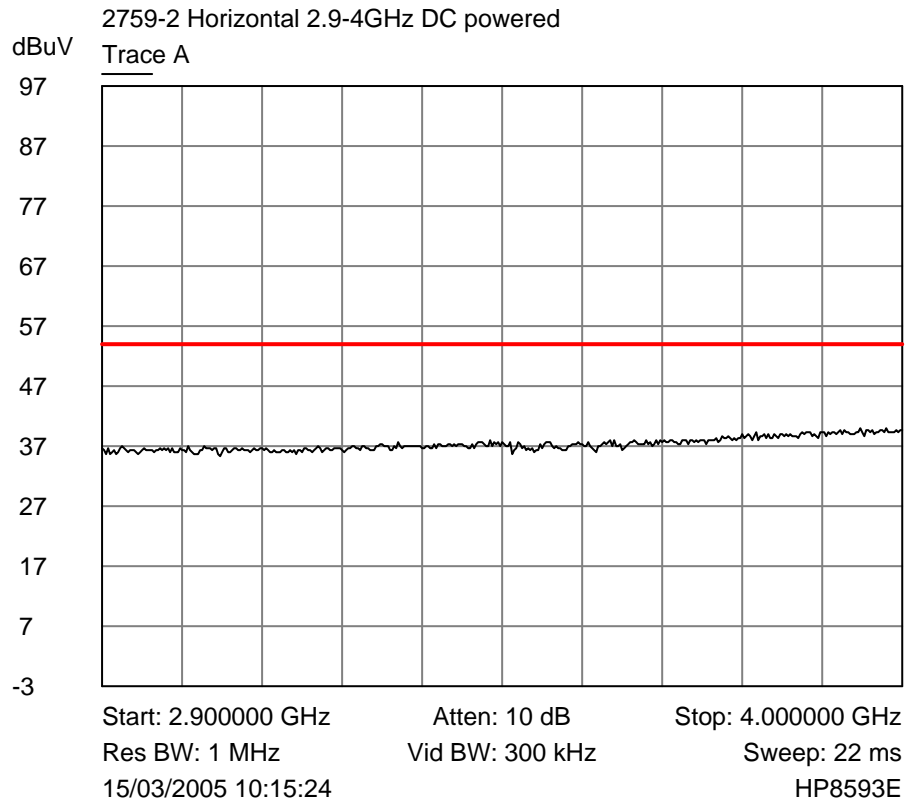

Average Values of 2.9 - 4 GHz. Horizontal Polarisation

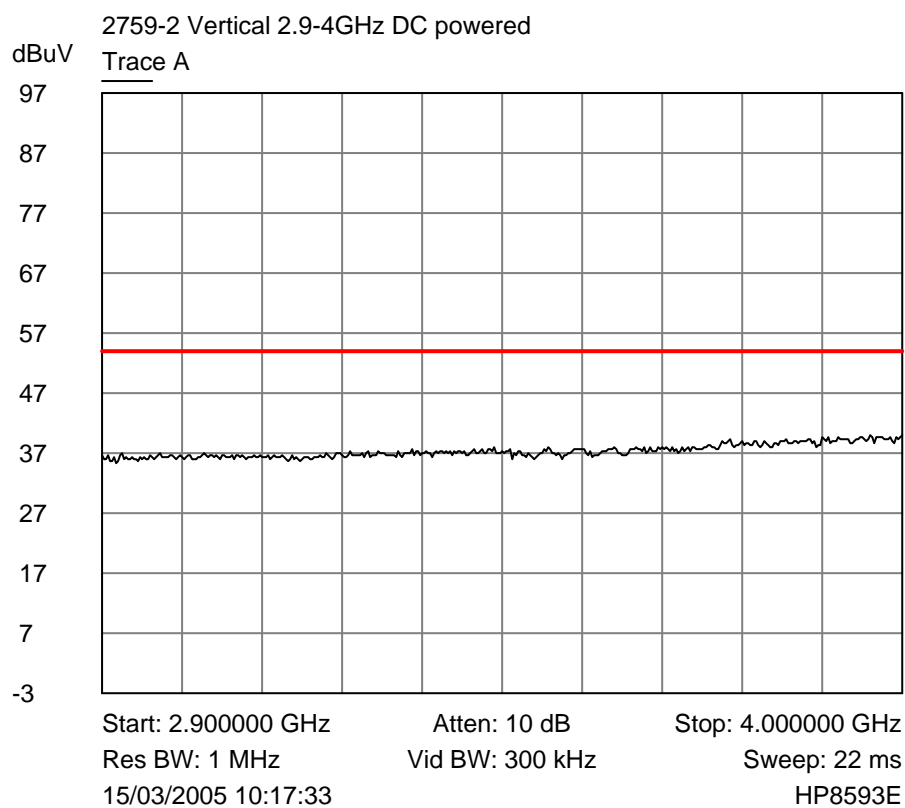

Average Values of 2.9 - 4GHz. Vertical Polarisation

6.2.2 Docked

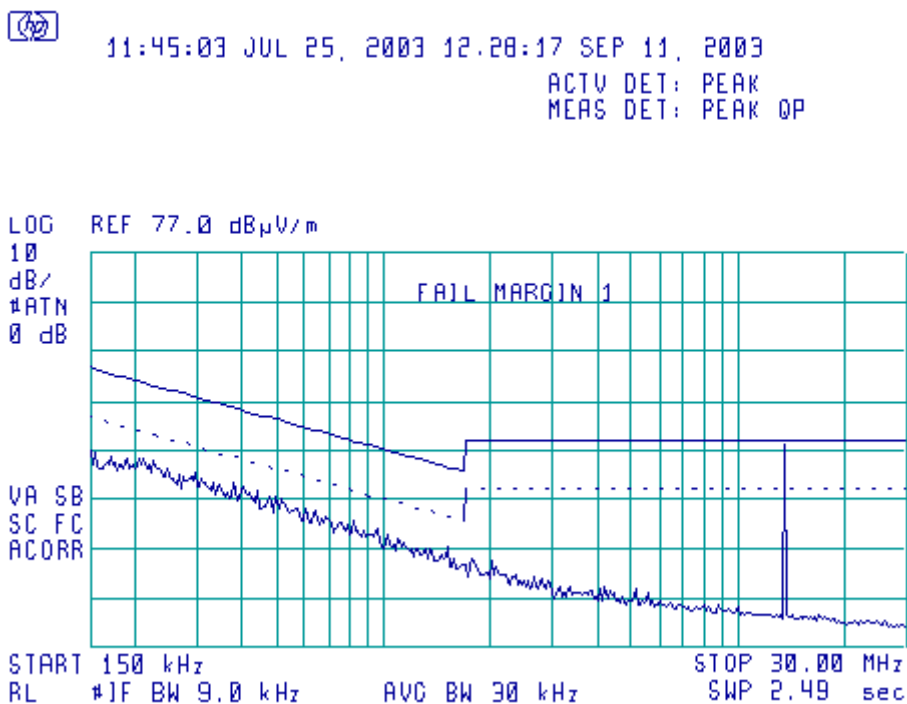

Quasi-Peak Values 490kHz to 30MHz.

The plot shows a swept response of peak values using the quasi-peak limit line



11:45:03 JUL 25, 2003 12:35:11 JAN 29, 2004

ACTV DET: PEAK
MEAS DET: PEAK QP

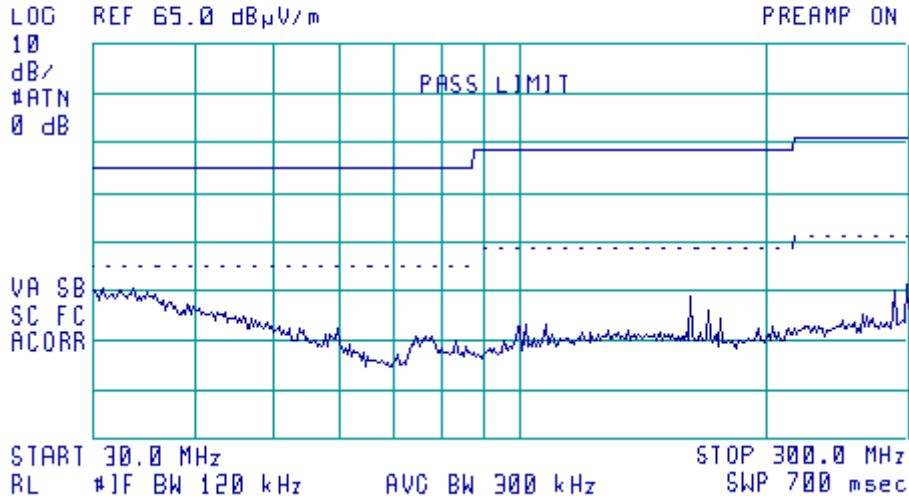

Quasi-Peak Values of 30 MHz. to 300 MHz. Horizontal Polarisation

The plot shows a swept response of peak values using the quasi-peak limit line

(Any peaks within 20dB of the limit line have been calculated and appear in the table on following page of this report)

Table of signals within 20dB of the limit line for Quasi-Peak Horizontal

None

Measurement Uncertainty of $\pm 5.2\text{dB}$ Applies



11:45:03 JUL 25, 2003 12:35:11 JAN 29, 2004

ACTV DET: PEAK
MEAS DET: PEAK QP

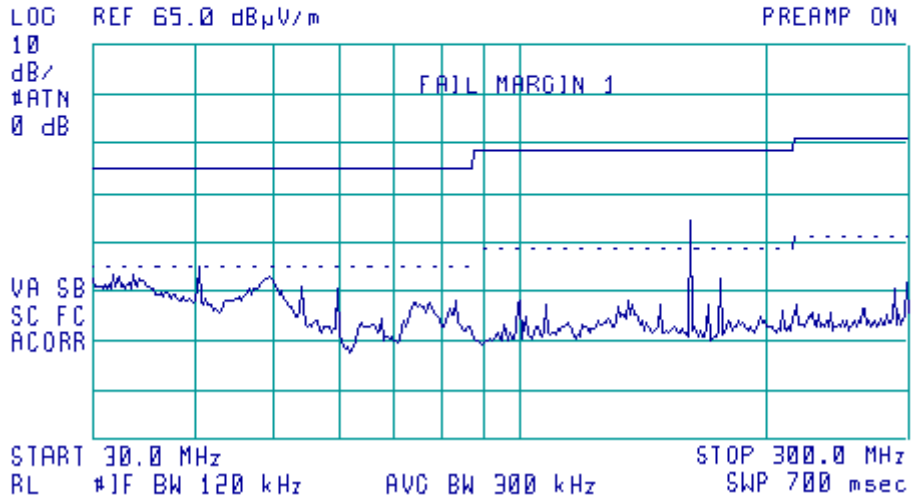

Quasi-Peak Values of 30 MHz. to 300 MHz. Vertical Polarisation

The plot shows a swept response of peak values using the quasi-peak limit line

(Any peaks within 20dB of the limit line have been calculated and appear in the table on following page of this report)

Table of signals for Quasi-peak Vertical

Signal	Freq (MHz)	Peak Amp (dBuV/m)	Peak - Lim1 (dB)	QP Amp (dBuV/m)	QP - Lim1 (dB)
	40.6844				
1	6	20.9	-19.1	18.53	-21.47
2	49.575	18.18	-21.82	14.07	-25.93
	84.0201				
3	8	15.12	-24.88	11.82	-28.18
	99.9772				
4	1	15.33	-28.17	11.71	-31.79
	162.716				
5	4	31.15	-12.35	29.94	-13.56
	176.267				
6	6	19.95	-23.55	17.57	-25.93

Measurement Uncertainty of ± 5.2dB Applies



11:45:03 JUL 25, 2003 12:35:11 JAN 29, 2004

ACTV DET: PEAK
MEAS DET: PEAK QP

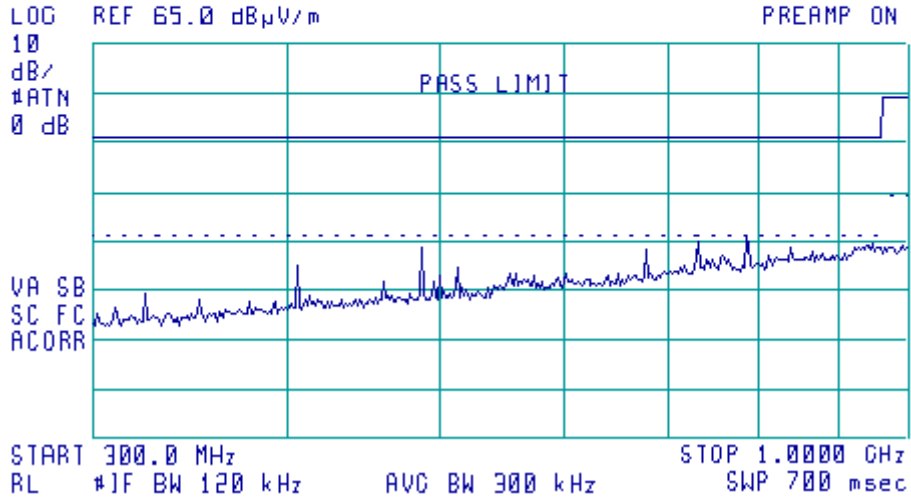

Quasi-Peak Values of 300 MHz. to 1 GHz. Horizontal Polarisation

The plot shows a swept response of peak values using the quasi-peak limit line

(Any peaks within 20dB of the limit line have been calculated and appear in the table on following page of this report)

Table of signals within 20dB of the limit line for Quasi-Peak Horizontal

NONE

Measurement Uncertainty of $\pm 5.2\text{dB}$ Applies



11:45:03 JUL 25, 2003 12:35:11 JAN 29, 2004

ACTV DET: PEAK
MEAS DET: PEAK QP
MKR 325.9 MHz
9.64 dB μ V/m

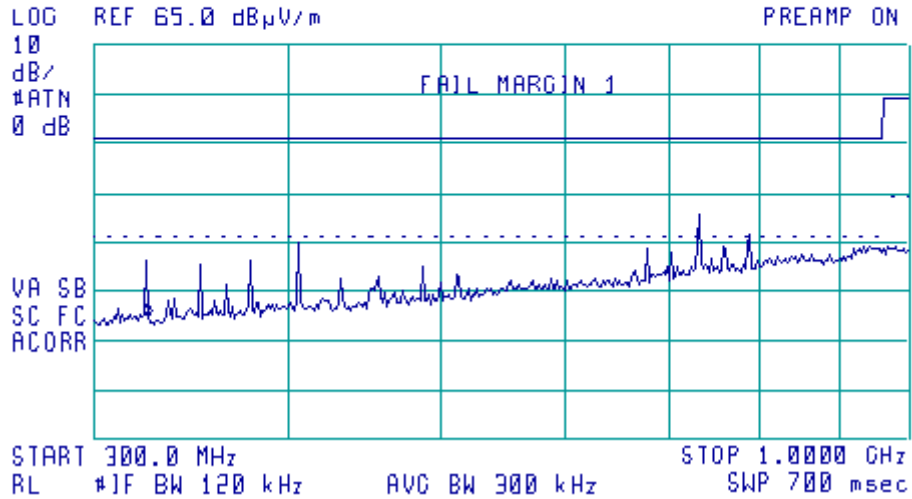

Quasi-Peak Values of 300 MHz. to 1 GHz. Vertical Polarisation

The plot shows a swept response of peak values using the quasi-peak limit line

(Any peaks within 20dB of the limit line have been calculated and appear in the table on following page of this report)

Table of signals for Quasi-peak Vertical

Signal	Freq (MHz)	Peak Amp (dBuV/m)	Peak - Lim1 (dB)	QP Amp (dBuV/m)	QP - Lim1 (dB)
	325.425				
1	7	23.3	-22.7	21.3	-24.7
	366.121				
2	6	19.43	-26.57	15.93	-30.07
	379.660				
3	6	25.16	-20.84	22.23	-23.77
	406.795				
4	8	26.74	-19.26	25	-21
	732.207				
5	3	33.04	-12.96	31.15	-14.85
	759.344				
6	8	27.56	-18.44	24.45	-21.55

Measurement Uncertainty of ± 5.2dB Applies

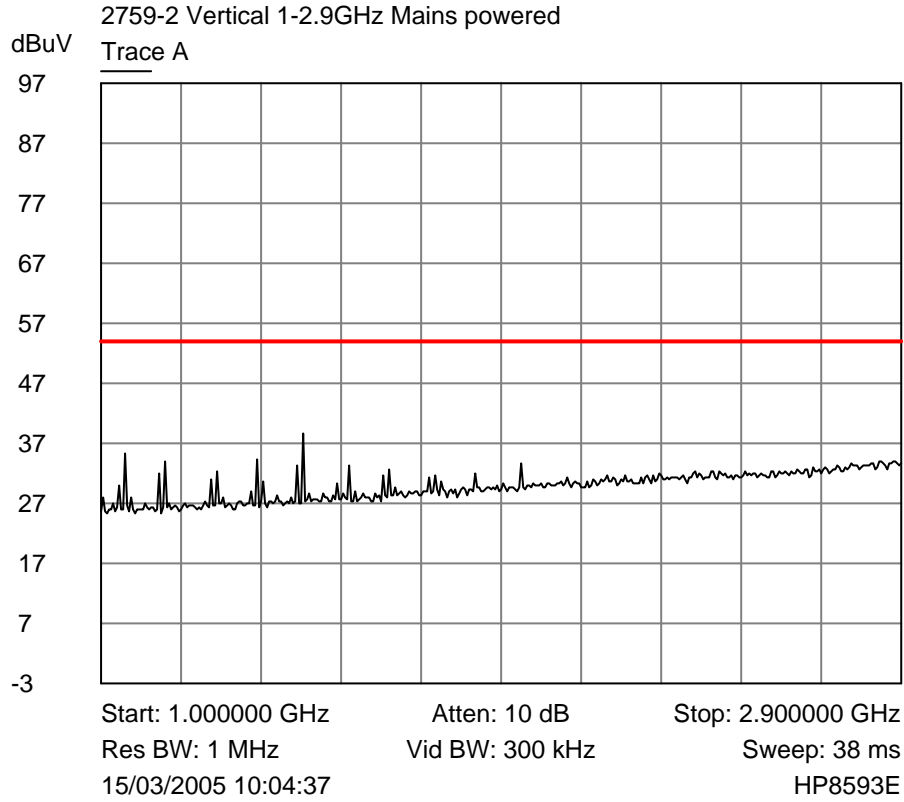

Average Values of 1 to 2.9GHz. Vertical Polarisation

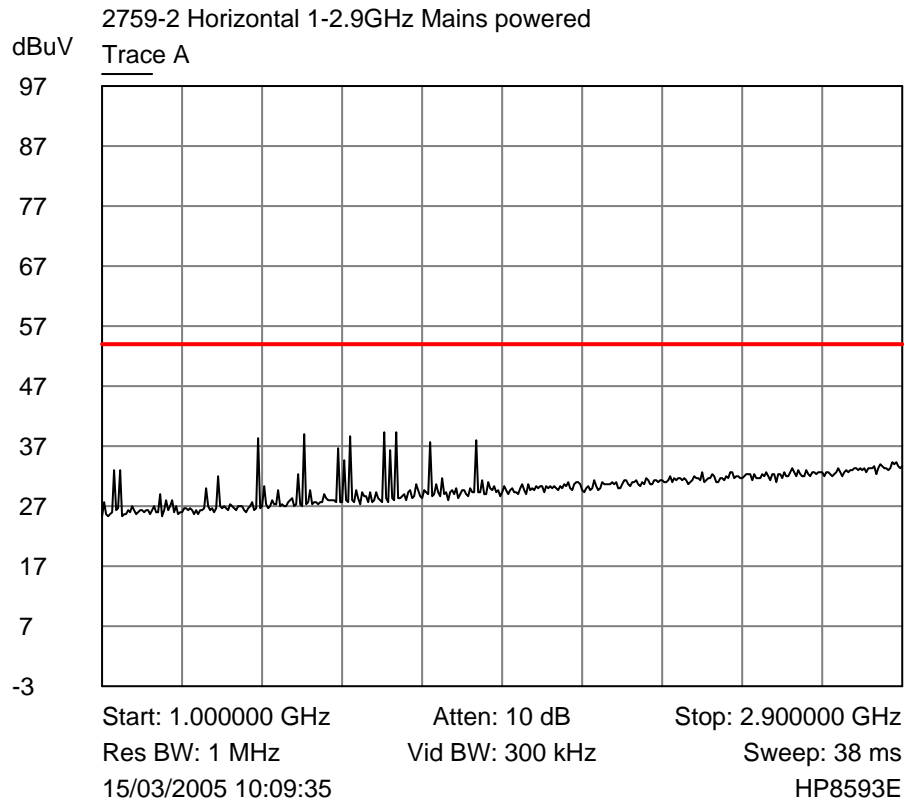

Average Values of 1 to 2.9GHz. Horizontal Polarisation

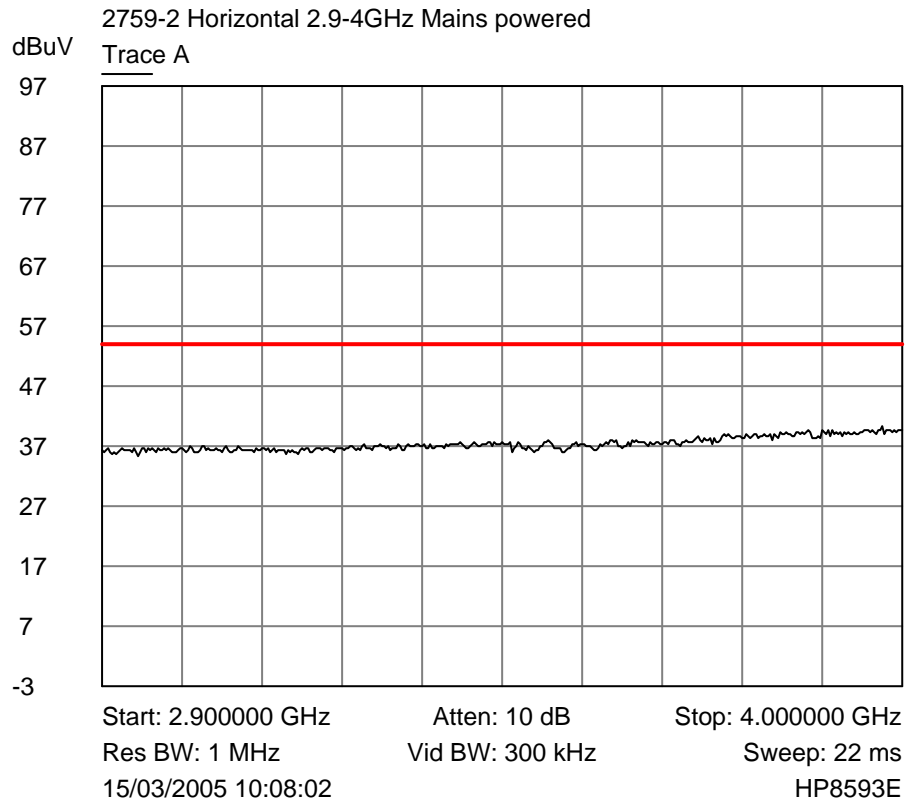

Average Values of 2.9 - 4 GHz. Horizontal Polarisation

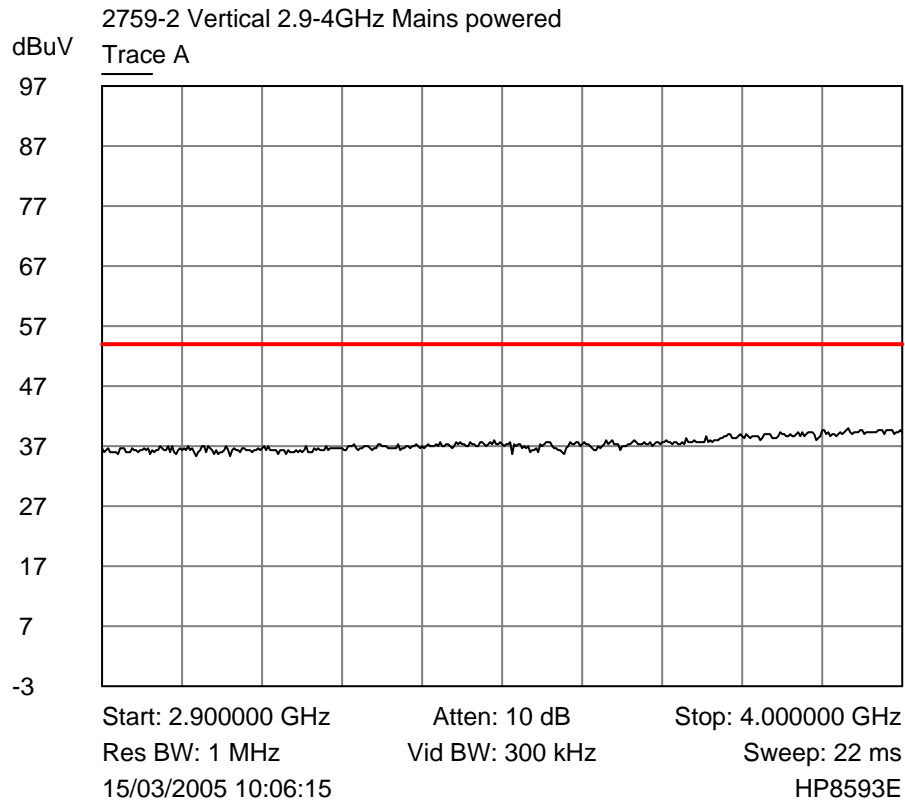

Average Values of 2.9 - 4GHz. Vertical Polarisation

6.3 Fundamental Emissions

6.3.1 Handheld

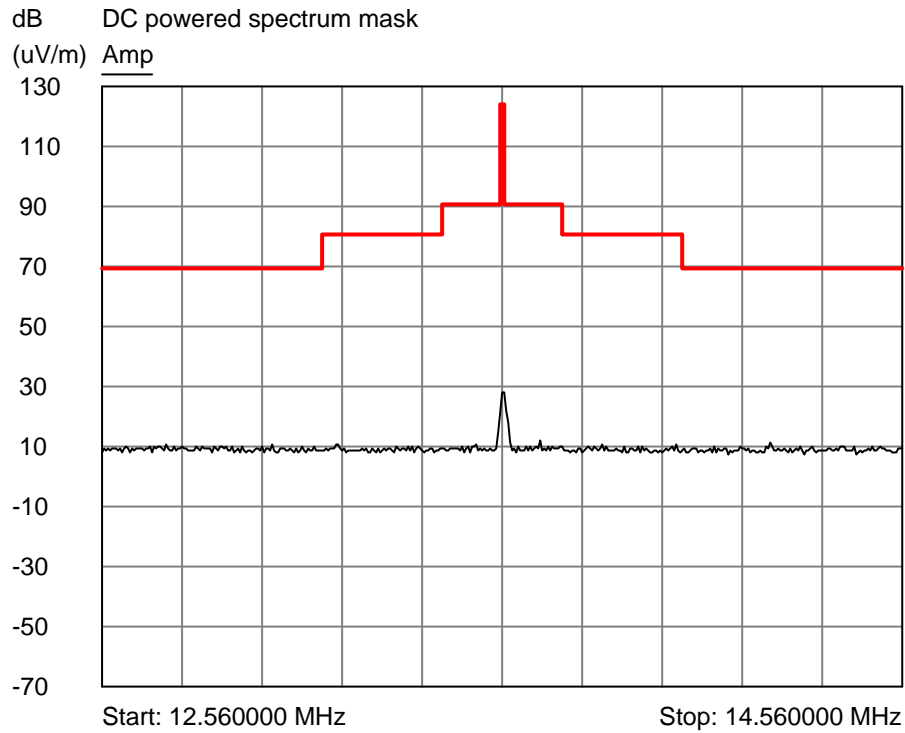

Peak Emission Spectrum

6.3.1 Docked

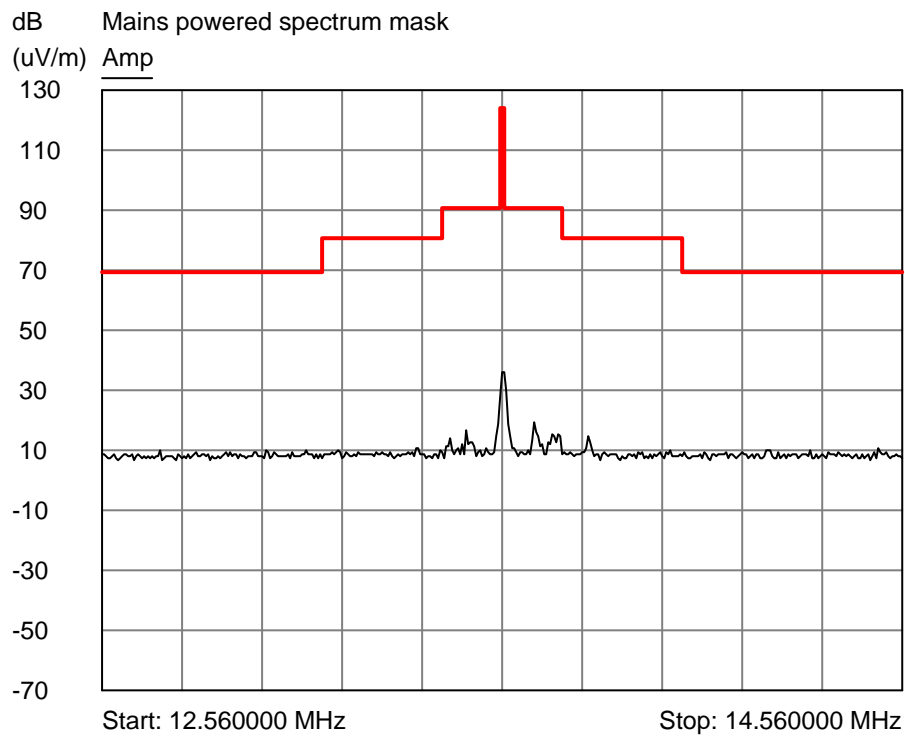

Peak Emission Spectrum

7. Explanatory Notes

7.1 Explanation of FAIL LIMIT 1 Statement

The **FAIL MARGIN 1** statement(s) may appear on the graphical plots when the receiver used to measure your equipment detects a signal that exceeds the dashed line. This does not mean that the Detect IV, has failed the test only that the 10 dB calculation margin set, has been exceeded on a peak measurement.

Following the indication that the margin has been exceeded, measurements are made at the frequency (ies) of the peaks. These peaks have been calculated to either Quasi Peak or Average Peak dependant on the test. A table of results has been printed on the reverse of the page. This table looks similar to the one illustrated below: -

Signal Number	Frequency (MHz)	Peak (dBμV)	PK Delta L 1 (dB)	Avg (dBμV)	Av Delta L 1 (dB)
1	12345.0000	12.9	-2.5	10.2	-5.2

The First column, labelled Signal Number, is a number that the receiver has given to each signal, which has been calculated.

Column Two, labelled Frequency (MHz), is the frequency of the signal received.

Column Three, labelled Peak (dBμV), (can also be labelled, in the case of Quasi Peak, Peak dBμV/m) is the Level that was received at peak amount in dB above 1μV.

Column Four, labelled PK Delta L1 (dB), is the same level as Column three but is given in a level relative to the limit line required.

Column Five, labelled AVG (dBμV), (can also be labelled, in the case of Quasi Peak, QP dBμV/m) when undertaking a Quasi peak test, This is the Average or Quasi peak calculation results given in dBμV or dBμV/m above 1μV.

Column Six, labelled AV Delta L 1 (dB), (can also be labelled, in the case of Quasi Peak, QP Delta L 1 (dB)) is the Average or Quasi Peak calculation relevant to the limit line. The results entered in this column indicate the signal level relative to the compliance limit required. Negative numbers indicate that the product is compliant.

7.2 Explanation of limit line calculations for radiated measurements

The limits given in the test standard are normally expressed as absolute values (e.g. in μV/m at a specified distance), whereas the measured values are expressed as peak, quasi peak or average values in dBμV/m referenced to the measuring instrument inputs. RN Electronics calibrate the test set-up to account for any path losses, antenna gains, etc. so that the value read at the receiver relates directly to the absolute value required, except that it is expressed in dB relative to one microVolt and may need to take account of any alternative measuring distance used. Examples:

- (a) limit of 500 μV/m equates to $20.\log(500) = 54 \text{ dB } \mu\text{V/m}$.
- (b) limit of 300 μV/m at 10m equates to $20.\log(300 \cdot 10/3) = 60 \text{ dB } \mu\text{V/m at 3m}$

8. Photographs



Photograph of the EUT (handheld) as viewed from in front of the loop / horn antennas, site M.

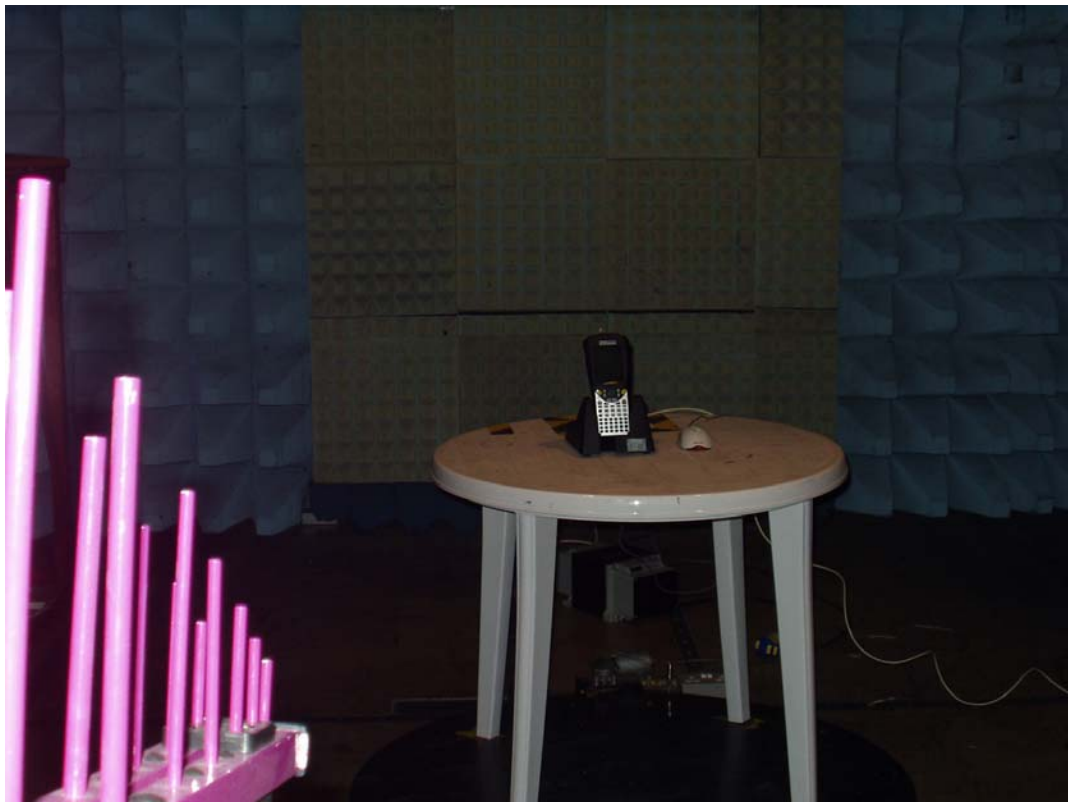

Photograph of the EUT (docked) as viewed from in front of the loop / horn antennas, site M.

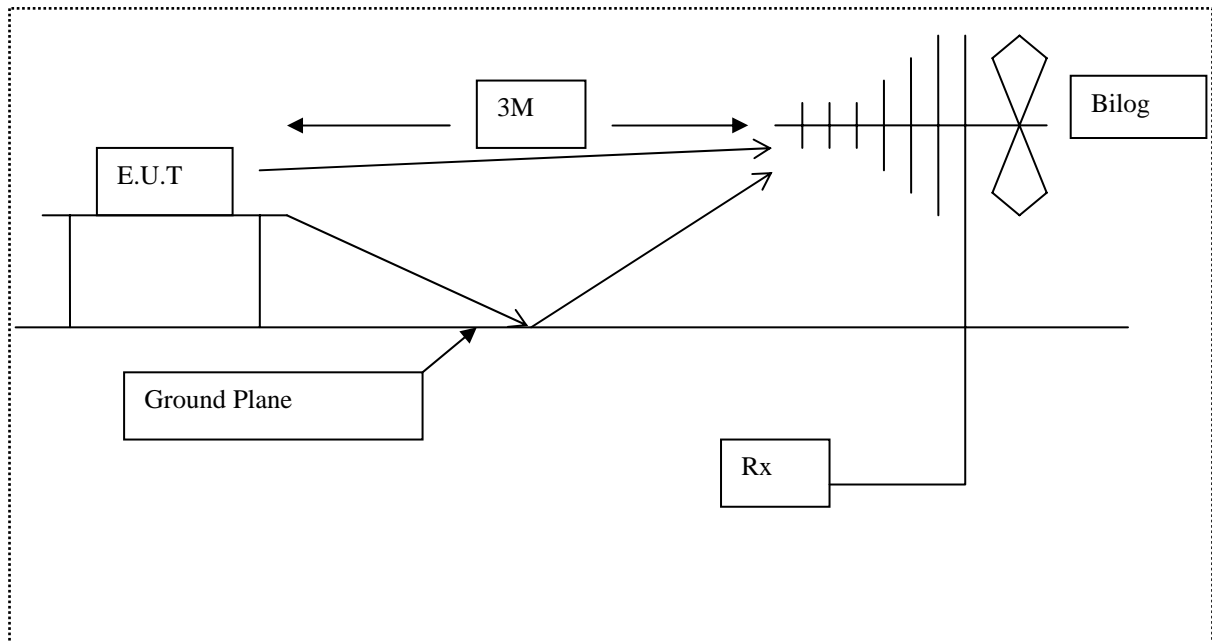

Diagram of the radiated emissions test setup.



Photograph of the EUT as viewed from screened room (conducted emissions)

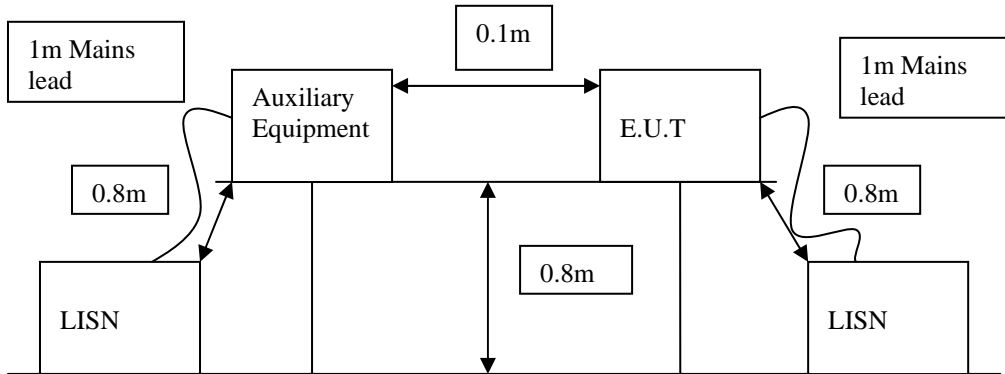

Diagram of the conducted emissions test setup.

9. Signal Leads

Port Name	Cable Type
AC/DC INPUT	Adaptor
USB	Multicore screened
MOUSE	Multicore unscreened

10. Test Equipment Calibration list

The Following is a list of the test equipment currently in use at **R.N. Electronics Ltd.** EMC test facility. In line with our procedures, to meet the requirements of ISO 9001, the equipment used will be within calibration for the period during which testing was carried out.

RNNNo	Model	Description	Manufacturer
e131	ESG-3000A	Signal Generator	Hewlett Packard
e10	MN2050	LISN 13A	Chase
e226	8546A	EMI Receiver	Hewlett Packard
e136	3105	Horn Antenna	EMCO
e3	HP8593E	Spectrum Analyser	Hewlett Packard
e35	HP11947A	Transient Limiter + 10dB Atten.	Hewlett Packard
tms32	-	3kVA Mains Variac	TGDC
tms38	VMT04/140	Environmental Oven	Heraeus Votsch
tms73	0.083333333	Off Air Standard	Quartzlock
tms80	206-3722	Digital Thermometer & K Probe	RS Components Ltd
tms81	6502	Active Loop Antenna	EMCO
tms814	MP627A	Doublet Antenna 200-1700 MHz	Anritsu Electric Co Ltd
tms815	MP534A/MP651A	Dipole Set 25 - 1700 MHz	Anritsu Electric Co Ltd
tms912	MN2053	LISN	Chase
tms907	TH200	Thermohygrometer	RS Components
tms82	8449B	Pre-amplifier 1-26GHz	Agilent
tms903	CBL6111A	Bilog Antenna 30MHz - 1GHz	Chase
tms933	CBL6141A	Bilog Antenna 30MHz - 2GHz	York EMC

11. Auxiliary equipment

11.1 Auxiliary equipment supplied by Psion Teklogix UK Ltd

Auxiliary equipment used for the purpose of test supplied by the above has been listed below

Manufacturer	Description	Model Number	Serial Number
Microsoft	Mouse	X08-71118	56180-576-2143155-1
Dell	PSU for laptop	ADP7DBM	TH-0936411-17971-7C
Belkin	USB Bluetooth adaptor	F8T001 ver2	BD000A3A54433F
Dell	Laptop	PPX	20300-OEM-001535-32116
-	USB Hub	-	-

11.2 Auxiliary equipment supplied by RN Electronics Limited

Auxiliary equipment used for the purpose of test supplied by the above has been listed below

Manufacturer	Description	Model Number	Serial Number
RN Electronics	Test Fixture	-	-

12. Modifications

In order for the EUT to produce the results shown within this report the following modifications, if any, were implemented.

None.

13. Compliance information

Products subject to the Declaration of Conformity procedure are required to be supplied with a compliance information statement. A copy of this statement may be included here:



Certificate of Test

The equipment noted below has been tested by **R.N. Electronics Limited** and conforms with the relevant subpart of FCC part 15, tested.

This certificate relates to the equipment, as identified by unique serial number(s) and further detailed in the referenced report, in the condition(s) at the time it was tested. It does not relate to any other similar equipment and performance of the product before or after the test cannot be guaranteed. Furthermore, this is a certificate of test only and should not be confused with an equipment authorisation.

Equipment:	Workabout Pro, ACG 13.56MHz RFID, Antenna, Docking Station, AC/DC Adaptor
Model Number(s):	7525C, HF AM1-A2, HF-A2, WA4002, LSE9912B0515
Unique Serial Number(s):	1247G035438, 270105CHM1020, 270105AHA2020, 1248D001868, A30417059761
Manufacturer:	Psion Teklogix UK Ltd
Customer Purchase Order Number:	108625
R.N. Electronics Limited Report Number:	03-599/2759/2/05A
Test Standards:	FCC Part 15C: effective date March 11 th 2005 Class DXX Intentional Radiator
Date:	31 st March 2005

For and on behalf of
R.N. Electronics Limited

Signature: