



Jan. 19, 2004

TIMCO ENGINEERING INC.

P.O. Box 370
849 N.W. State Road 45
Newberry, Florida

Subject: FCC Certification Authorization Application under FCC Part 15, Subpart C, Sec. 15.247 - Digital Modulation Transmitters operating in the frequency band 2400 - 2483.5 MHz.

Product: 7535 Handheld Computer with USI Radio Model No.: CF-B-AG-02 (FCC ID: IXMCF-B-AG-1)

**Model No.: 7535
FCC ID: GM3CFBAG02**

Dear Sir/Madam,

As appointed agent for Psion Teklogix Inc., we would like to submit the application to the Federal Communications Commission for certification of the above product. Please review all necessary files uploaded to TIMCO Upload Web Site.

- Compliance with RF Exposure Requirements: the transmitter complies with FCC 2.1093 and FCCOET Bulletin 65 (August 1997) with maximum 0.77 W/Kg with brain tissue at head position and 0.77 W/Kg with body tissue at hip position. Please refer to attached SAR test report.

If you have any queries, please do not hesitate to contact us.

Yours truly,



Tri Minh Luu, P. Eng.,
V.P., Engineering

Encl

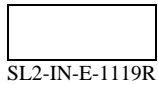

3000 Bristol Circle,
Oakville, Ontario,
Canada L6H 6G4

Tel.: (905) 829-1570
Fax.: (905) 829-8050

Website: www.ultratech-labs.com
Email: vic@ultratech-labs.com



31040/SIT



C-1376



46390-2049



200093-0



00-034



SL2-IN-E-1119R



entela

3000 Bristol Circle,
Oakville, Ontario,
Canada L6H 6G4

Tel.: (905) 829-1570
Fax.: (905) 829-8050

Website: www.ultratech-labs.com
Email: vic@ultratech-labs.com

Jan. 19, 2004

Psion Teklogix Inc.
2100 Meadowvale Blvd.
Mississauga, ON
Canada, L5N 7J9

Attn.: Mr. Sada Dharwarkar

Subject: FCC Certification Application Testing under FCC Part 15,
Subpart C, Sec. 15.247 - Digital Modulation Transmitters
operating in the frequency band 2400 - 2483.5 MHz.

Product: 7535 Handheld Computer with USI Radio Model No.: CF-B-
AG-02 (FCC ID: IXMCF-B-AG-1)

Model No.: 7535
FCC ID: GM3CFBAG02

Dear Mr. Dharwarkar,

The product sample, as provided by you, has been tested and found to comply with **FCC Part 15, Subpart C, Sec. 15.247 - Digital Modulation Transmitters operating in the frequency band 2400 - 2483.5 MHz.**

- Compliance with RF Exposure Requirements: The transmitter complies with FCC 2.1093 and FCCOET Bulletin 65 (August 1997) with maximum 0.77 W/Kg with brain tissue at head position and 0.77 W/Kg with body tissue at hip position. Please refer to attached SAR test report.

Enclosed you will find copies of the engineering report. If you have any queries, please do not hesitate to contact us.

Yours truly,



Tri Minh Luu, P. Eng.,
V.P., Engineering

Encl.

ENGINEERING TEST REPORT

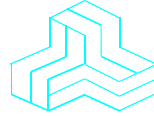

7535 Handheld Computer
with USI 802.11b WLAN CF Radio Transceiver Card, Model No.: CF-B-AG-02
Model No.: 7535

FCC ID: GM3CFBAG02

Applicant: **Psion Teklogix Inc.**
2100 Meadowvale Blvd.
Mississauga, ON
Canada, L5N 7J9

In Accordance With

FEDERAL COMMUNICATIONS COMMISSION (FCC)
PART 15, SUBPART C, SEC. 15.247
Digital Modulation Transmitters operating in the frequency
band 2400 - 2483.5 MHz

UltraTech's File No.: TEK-434FCC15C

This Test report is Issued under the Authority of
Tri M. Luu, Professional Engineer,
Vice President of Engineering
UltraTech Group of Labs



Date: Jan. 19, 2004

Report Prepared by: Tri Luu

Tested by: Hung Trinh

Issued Date: Jan. 19, 2004

Test Dates: Dec. 19-23 & Jan. 16, 2003

- *The results in this Test Report apply only to the sample(s) tested, and the sample tested is randomly selected.*
- *This report must not be used by the client to claim product endorsement by NVLAP or any agency of the US Government.*

UltraTech

3000 Bristol Circle, Oakville, Ontario, Canada, L6H 6G4
Tel.: (905) 829-1570 Fax.: (905) 829-8050

Website: www.ultratech-labs.com Email: vic@ultratech-labs.com, Email: tri.luu@sympatico.ca



31040/SIT



C-1376



46390-2049



200093-0

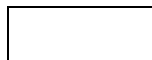

SL2-IN-E-1119R



00-034



TABLE OF CONTENTS

EXHIBIT 1.	SUBMITTAL CHECK LIST	4
EXHIBIT 2.	INTRODUCTION	5
2.1.	SCOPE	5
2.2.	RELATED SUBMITAL(S)/GRANT(S).....	5
2.3.	NORMATIVE REFERENCES	5
EXHIBIT 3.	PERFORMANCE ASSESSMENT	6
3.1.	CLIENT INFORMATION	6
3.2.	EQUIPMENT UNDER TEST (EUT) INFORMATION	6
3.3.	EUT'S TECHNICAL SPECIFICATIONS	7
3.4.	LIST OF EUT'S PORTS	8
EXHIBIT 4.	EUT OPERATING CONDITIONS AND CONFIGURATIONS DURING TESTS.....	9
4.1.	CLIMATE TEST CONDITIONS	9
4.2.	OPERATIONAL TEST CONDITIONS & ARRANGEMENT FOR TESTS	9
EXHIBIT 5.	SUMMARY OF TEST RESULTS.....	14
5.1.	LOCATION OF TESTS.....	14
5.2.	APPLICABILITY & SUMMARY OF EMC EMISSION TEST RESULTS.....	14
5.3.	MODIFICATIONS INCORPORATED IN THE EUT FOR COMPLIANCE PURPOSES	14
EXHIBIT 6.	MEASUREMENTS, EXAMINATIONS & TEST DATA FOR EMC EMISSIONS	15
6.1.	TEST PROCEDURES	15
6.2.	MEASUREMENT UNCERTAINTIES	15
6.3.	MEASUREMENT EQUIPMENT USED:.....	15
6.4.	ESSENTIAL/PRIMARY FUNCTIONS AS DECLARED BY THE MANUFACTURER:.....	15
6.5.	COMPLIANCE WITH FCC PART 15 – GENERAL TECHNICAL REQUIREMENTS.....	16
6.6.	6 dB BANDWIDTH @ FCC 15.247(A)(2)	17
6.6.1.	<i>Limits</i>	17
6.6.2.	<i>Method of Measurements</i>	17
6.6.3.	<i>Test Arrangement</i>	17
6.6.4.	<i>Test Equipment List</i>	17
6.6.5.	<i>Test Data</i>	17
6.7.	PEAK OUTPUT POWER (CONDUCTED) @ FCC 15.247(B)	21
6.7.1.	<i>Limits</i>	21
6.7.2.	<i>Method of Measurements & Test Arrangement</i>	21
6.7.3.	<i>Test Equipment List</i>	21
6.7.4.	<i>Test Data</i>	21
6.8.	RF EXPOSURE REQUIRMENTS @ FCC 15.247(B)(4), 1.1310 & 2.1091	22
6.9.	TRANSMITTER BAND-EDGE & SPURIOUS EMISSIONS (CONDUCTED), FCC CFR 47, PARA. 15.247(C)	23
6.9.1.	<i>Limits</i>	23
6.9.2.	<i>Method of Measurements</i>	23
6.9.3.	<i>Test Arrangement</i>	23
6.9.4.	<i>Test Equipment List</i>	23
6.9.5.	<i>Test Data</i>	24
6.10.	TRANSMITTED POWER DENSITY OF A DIGITAL MODULATION SYSTEM, FCC CFR 47, PARA. 15.247(D).....	33
6.10.1.	<i>Limits</i>	33
6.10.2.	<i>Method of Measurements</i>	33
6.10.3.	<i>Test Arrangement</i>	33

ULTRATECH GROUP OF LABS

3000 Bristol Circle, Oakville, Ontario, Canada L6H 6G4
Tel. #: 905-829-1570, Fax. #: 905-829-8050, Email: vic@ultratech-labs.com, Website: <http://www.ultratech-labs.com>

File #: TEK-434FCC15C

Jan. 19, 2004

6.10.4.	Test Equipment List	33
6.10.5.	Test Data	34
6.11.	SPURIOUS EMISSIONS (RADIATED @ 3 METERS), FCC CFR 47, PARA. 15.247(c), 15.209 & 15.205 ..	38
6.11.1.	Limits	38
6.11.2.	Method of Measurements	39
6.11.3.	Test Arrangement	39
6.11.4.	Test Equipment List	39
6.11.5.	Photographs of Test Setup	39
6.11.6.	Test Data	39
EXHIBIT 7.	MEASUREMENT UNCERTAINTY	50
7.1.	LINE CONDUCTED EMISSION MEASUREMENT UNCERTAINTY	50
7.2.	RADIATED EMISSION MEASUREMENT UNCERTAINTY	51
EXHIBIT 8.	MEASUREMENT METHODS	52
8.1.	GENERAL TEST CONDITIONS	52
8.1.1.	Normal temperature and humidity	52
8.1.2.	Normal power source	52
8.1.3.	Operating Condition of Equipment under Test	52
8.2.	METHOD OF MEASUREMENTS - AC MAINS CONDUCTED EMISSIONS	53
8.3.	PEAK CONDUCTED POWER & PEAK EIRP	54
8.3.1.	Measurements of Transmitter Parameters (Duty Cycle & Peak Power)	54
8.4.	SPURIOUS EMISSIONS (CONDUCTED & RADIATED)	57
8.4.1.	Band-edge and Spurious Emissions (Conducted)	57
8.4.2.	Spurious Emissions (Radiated)	57
8.5.	ALTERNATIVE TEST PROCEDURES	59
8.5.1.	Peak Power Measurements	59
8.5.2.	Spurious RF conducted emissions	60
8.6.	TRANSMITTED POWER DENSITY OF A DIGITAL MODULATION SYSTEM	60

EXHIBIT 1. SUBMITTAL CHECK LIST

Annex No.	Exhibit Type	Description of Contents	Quality Check (OK)
	Test Report	Test Report	OK
1	Test Setup Photos	Photos # 1 to 3	OK
2	External Photos of EUT	Photos # 1 to 2	OK
3	Internal Photos of EUT	Photos of 1 to 21	OK
4	Cover Letters	<ul style="list-style-type: none">Letter from Ultratech for Certification Request	OK
5	Attestation Statements	<ul style="list-style-type: none">Letter from the Applicant to appoint Ultratech to act as an agentLetter from the Applicant to request for Confidentiality Filing	OK OK
6	ID Label/Location Info	<ul style="list-style-type: none">ID LabelLocation of ID Label	OK
7	Block Diagrams	<ul style="list-style-type: none">Block diagrams	OK
8	Schematic Diagrams	<ul style="list-style-type: none">Schematic diagrams	OK
9	Parts List/Tune Up Info	Parts List/Tune Up Info	OK
10	Operational Description	Operational Description	OK
11	RF Exposure Info	RF Exposure Info	OK
12	Users Manual	Users Manual	OK

ULTRATECH GROUP OF LABS

3000 Bristol Circle, Oakville, Ontario, Canada L6H 6G4
Tel. #: 905-829-1570, Fax. #: 905-829-8050, Email: vic@ultratech-labs.com, Website: <http://www.ultratech-labs.com>

File #: TEK-434FCC15C
Jan. 19, 2004

- All test results contained in this engineering test report are traceable to National Institute of Standards and Technology (NIST)

EXHIBIT 2. INTRODUCTION

2.1. SCOPE

Reference:	FCC Part 15, Subpart C, Section 15.247
Title	Telecommunication - Code of Federal Regulations, CFR 47, Part 15
Purpose of Test:	To gain FCC Certification Authorization for Digital Modulation Transmitters operating in the Frequency Band 2400 - 2483.5 MHz .
Test Procedures	Both conducted and radiated emissions measurements were conducted in accordance with American National Standards Institute ANSI C63.4 - American National Standard for Methods of Measurement of Radio-Noise Emissions from Low-Voltage Electrical and Electronic Equipment in the Range of 9 kHz to 40 GHz.
Environmental Classification:	<ul style="list-style-type: none"> • Light-industry, Commercial • Industry

2.2. RELATED SUBMITAL(S)/GRANT(S)

None

2.3. NORMATIVE REFERENCES

Publication	YEAR	Title
FCC CFR Parts 0-19	2002	Code of Federal Regulations – Telecommunication
ANSI C63.4	1992	American National Standard for Methods of Measurement of Radio-Noise Emissions from Low-Voltage Electrical and Electronic Equipment in the Range of 9 kHz to 40 GHz
CISPR 22 & EN 55022	2002 2003	Limits and Methods of Measurements of Radio Disturbance Characteristics of Information Technology Equipment
CISPR 16-1	1993	Specification for Radio Disturbance and Immunity measuring apparatus and methods
FCC Public Notice DA 00-705	2000	Filing and Measurement Guidelines for Frequency Hopping Spread Spectrum Systems
FCC ET Docket No. 99-231	2002	Amendment to FCC Part 15 of the Commission's Rules Regarding to Spread Spectrum Devices

EXHIBIT 3. PERFORMANCE ASSESSMENT

3.1. CLIENT INFORMATION

APPLICANT:	
Name:	Psion Teklogix Inc.
Address:	2100 Meadowvale Blvd. Mississauga, ON Canada, L5N 7J9
Contact Person:	Mr. Sada Dharwarkar Phone #: 905-812-6200 (3358) Fax #: 905-812-6301 Email Address: sdharwar@teklogix.com

MANUFACTURER:	
Name:	Psion Teklogix Inc.
Address:	2100 Meadowvale Blvd. Mississauga, ON Canada, L5N 7J9
Contact Person:	Mr. Sada Dharwarkar Phone #: 905-812-6200 (3358) Fax #: 905-812-6301 Email Address: sdharwar@teklogix.com

3.2. EQUIPMENT UNDER TEST (EUT) INFORMATION

The following information (with the exception of the Date of Receipt) has been supplied by the applicant.

Brand Name	Psion Teklogix Inc.
Product Name	7535 Handheld Computer with USI Radio Model No.: CF-B-AG-02
Model Name or Number	7535
Serial Number	B012
Type of Equipment	Digital Modulation Transmitters
Input Power Supply Type	• Internal Battery
Primary User Functions of EUT:	Provide data communication link through air

3.3. EUT'S TECHNICAL SPECIFICATIONS

TRANSMITTER	
Equipment Type:	▪ Portable
Intended Operating Environment:	▪ Commercial, light industry & heavy industry
Power Supply Requirement:	
RF Output Power Rating:	0.0361 Watts
Operating Frequency Range:	2412 - 2462 MHz
RF Output Impedance:	50 Ohms
Channel Spacing:	
Duty Cycle:	100%
6 dB Bandwidth:	9.93 MHz
Modulation Type:	IEEE 802.11b: <ul style="list-style-type: none"> • DBPSK for 1Mb/s Data Rate • DQPSK for 2 Mb/s Data Rate • CCK for 5.5 Mb/s Data Rate • CCK for 11 Mb/s Data Rate
Emission Designation:	Digital Modulation
Oscillator Frequencies:	
Spectral Density	3.6 mW/MHz (Power output at the antenna / bandwidth of the RF output spectrum)
Antenna Connector Type:	<ul style="list-style-type: none"> • Integral (the antenna component is soldered onto the radio printed circuit board and located inside the enclosure)
Antenna Description:	<p><u>Alternative Antenna #1:</u> Manufacturer: Psion Teklogix Type: integrated inside the plastic enclosure Connector Type: HIROSE U.FL Model: 1020096-100 Frequency Range: 2400-2500 MHz In/Out Impedance: 50 Ohms Gain: 0 dBi</p> <p><u>Alternative Antenna #2:</u> Manufacturer: Walsin Technology Corporation Type: Monopole Ceramic, integrated inside the plastic enclosure Model: RFANT 5220110A0T Frequency Range: 2400-2500 MHz In/Out Impedance: 50 Ohms Gain: 2 dBi</p>

3.4. LIST OF EUT'S PORTS

Port Number	EUT's Port Description	Number of Identical Ports	Connector Type	Cable Type (Shielded/Non-shielded)
1	Tether Port	1	--	8' long, shielded decoded scanner cable terminated with a scanner

ULTRATECH GROUP OF LABS

3000 Bristol Circle, Oakville, Ontario, Canada L6H 6G4
Tel. #: 905-829-1570, Fax. #: 905-829-8050, Email: vic@ultratech-labs.com, Website: <http://www.ultratech-labs.com>

File #: TEK-434FCC15C
Jan. 19, 2004

- All test results contained in this engineering test report are traceable to National Institute of Standards and Technology (NIST)

EXHIBIT 4. EUT OPERATING CONDITIONS AND CONFIGURATIONS DURING TESTS

4.1. CLIMATE TEST CONDITIONS

The climate conditions of the test environment are as follows:

Temperature:	21°C
Humidity:	51%
Pressure:	102 kPa
Power input source:	

4.2. OPERATIONAL TEST CONDITIONS & ARRANGEMENT FOR TESTS

Operating Modes:	<ul style="list-style-type: none"> ▪ Each of lowest, middle and highest channel frequencies transmits continuously for emissions measurements. ▪ The EUT operates in normal Direct Sequence mode for occupancy duration, and frequency separation.
Special Test Software:	<ul style="list-style-type: none"> ▪ Special software is provided by the Applicant to select and operate the EUT at each channel frequency continuously. For example, the transmitter will be operated at each of lowest, middle and highest frequencies individually continuously during testing.
Special Hardware Used:	N/A
Transmitter Test Antenna:	The EUT is tested with the antenna fitted in a manner typical of normal intended use as an integral antenna equipment.

Transmitter Test Signals:	
Frequencies: <ul style="list-style-type: none"> ▪ 2412 - 2462 MHz band: 	Lowest, middle and highest channel frequencies tested: 2412, 2437 & 2462 MHz
Transmitter Wanted Output Test Signals: <ul style="list-style-type: none"> ▪ RF Power Output (measured maximum output power): ▪ Normal Test Modulation ▪ Modulating signal source: 	<ul style="list-style-type: none"> ▪ 0.0361 Watts ▪ CCK @ 11 Mb/s ▪ Internal

Radio Approval Product Configuration

Title:	Author:	File Name:	Date:
Radio Approvals Product Configuration	Sada Dharwarkar	7535 USI CF-B-AG-02 FCC_IC.doc	2003.11.13

PRODUCT UNDER TEST	7535 + USI Radio Model: CF-B-AG-02
DESTINATION COUNTRY	USA & Canada
APPLICABLE STANDARD	FCC PART 15.247, 15.205, 15.109 & 15.107/RSS-210
EQUIPMENT CLASS	Class B
EQUIPMENT TYPE	Radio equipment
TESTER	Sada Dharwarkar
DATE	Tuesday 13 th November, 2003

Revision	Date	Change Description	by	Comments
Draft 1	2003-11.13	Initial Draft	Sada Dharwarkar	

ULTRATECH GROUP OF LABS

3000 Bristol Circle, Oakville, Ontario, Canada L6H 6G4
Tel. #: 905-829-1570, Fax. #: 905-829-8050, Email: vic@ultratech-labs.com, Website: <http://www.ultratech-labs.com>

File #: TEK-434FCC15C
Jan. 19, 2004

- All test results contained in this engineering test report are traceable to National Institute of Standards and Technology (NIST)

HARDWARE	
MANUFACTURER	Psion Teklogix
PRODUCT	Handheld Computer
MODEL NUMBER	7535
TEKLOGIX PART NUMBER	N/A
SERIAL NUMBER	B012
MLB PART NUMBER	1916121 Rev B
MLB SERIAL NUMBER	
RAM SIZE	64 MB
MEMORY EXPANSION BOARD	None
CPU SPEED	400 MHz
MISCELANEOUS HARDWARE	
MANUFACTURER	Symbol
PRODUCT	Standard Range Undecoded Internal Scanner
MODEL NUMBER	SE1200 HP-I001
SERIAL NUMBER	
TEKLOGIX PART NUMBER	
MISCELANEOUS HARDWARE	
MANUFACTURER	Psion Teklogix
PRODUCT	Battery
MODEL NUMBER	
SERIAL NUMBER	
TEKLOGIX PART NUMBER	

SOFTWARE	
SOFTWARE VERSION (7535)	Microsoft Windows CE.NET Version 4.1 (Build 908) E263r
BOOT CODE VERSION (7535)	E013n
ASIC	N/A
PERIPHERAL CONTROLLER	
APPLICATION TYPE	N/A
APPLICATION VERSION	N/A
CLOCK SPEED (7535)	400 MHz
OSCILLATOR FREQUENCIES (7535)	32.768 KHz, 6.0 MHz, 3.6864 MHz, 7.3728 MHz, 95.846 MHz, 147.46 MHz, 47.923 MHz, 31.949 MHz, 19.169 MHz, 14.746 MHz, 100 MHz, 200 MHz, 400 MHz
IP ADDRESS	N/A
ESSID	N/A

ULTRATECH GROUP OF LABS

3000 Bristol Circle, Oakville, Ontario, Canada L6H 6G4
 Tel. #: 905-829-1570, Fax. #: 905-829-8050, Email: vic@ultratech-labs.com, Website: <http://www.ultratech-labs.com>

File #: TEK-434FCC15C
 Jan. 19, 2004

- All test results contained in this engineering test report are traceable to National Institute of Standards and Technology (NIST)

RADIO	
LOCATION	CF Slot
MANUFACTURER:	USI
PRODUCT	2.4 GHz DSSS 11MB Compact Flash Card
MODEL NUMBER	CF-B-AG-02
TEKLOGIX MODEL NUMBER	RA2020
SERIAL NUMBER	03UT01390237
FCC ID	GM3CFBAG02
POWER	15 dBm
FREQUENCY RANGE	2.412 to 2.462 GHz
DATA RATES	1, 2, 5.5, 11 Mbps
CHANNELS	11 (FCC)
L.O. FREQUENCIES	2.32 – 2.62 GHz
REF. OSC. FREQUENCIES	44 MHz, 14.67 MHz
INTERNAL/EXTRENAL ANTENNA	External
RF CABLE TYPE	Hirose U.FL-LP-5016-A-(80)
ANTENNA TYPE + GAIN	PCB 0 dBi
TEKLOGIX PART NUMBER	1010096

ACCESSORIES	
TYPE	Decoded Laser Scanner
MANUFACTURER	PSC
MODEL NUMBER	POWERSCAN
TEKLOGIX PART NUMBER	
SERIAL NUMBER	

TEST CONFIGURATION				
INTERFACE PORT	CABLE TYPE	CABLE LENGTH	SHEILDED (S/NS)	COMMENTS
Tether Port	Decoded Scanner Cable	8'	Shielded	Terminated with Scanner

ULTRATECH GROUP OF LABS

3000 Bristol Circle, Oakville, Ontario, Canada L6H 6G4
 Tel. #: 905-829-1570, Fax. #: 905-829-8050, Email: vic@ultratech-labs.com, Website: <http://www.ultratech-labs.com>

File #: TEK-434FCC15C
 Jan. 19, 2004

- All test results contained in this engineering test report are traceable to National Institute of Standards and Technology (NIST)

BLOCK DIAGRAM OF TEST SETUP

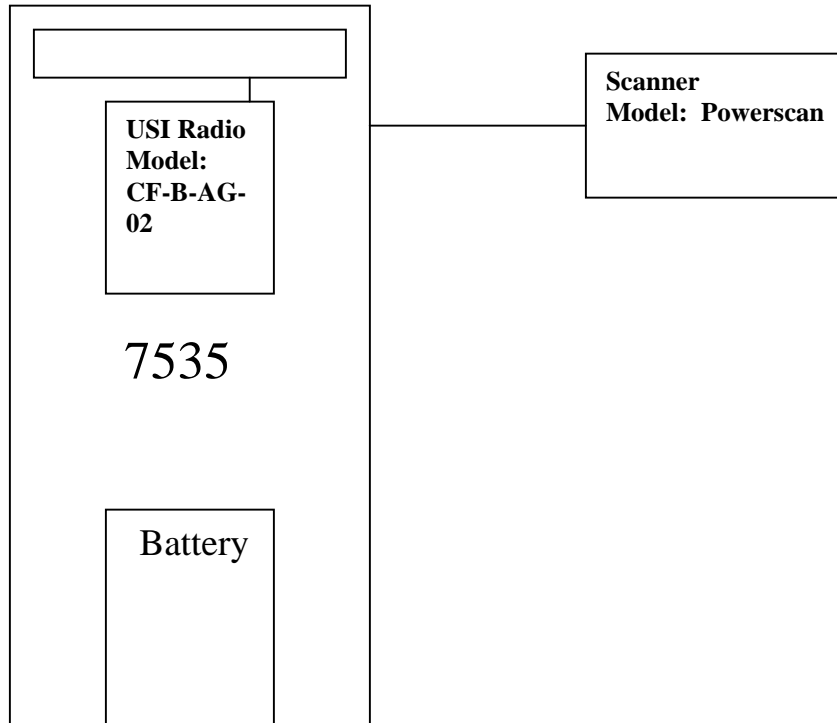

EXHIBIT 5. SUMMARY OF TEST RESULTS

5.1. LOCATION OF TESTS

All of the measurements described in this report were performed at Ultratech Group of Labs located in the city of Oakville, Province of Ontario, Canada.

- AC Powerline Conducted Emissions were performed in UltraTech's shielded room, 16'(L) by 12'(W) by 12'(H).
- Radiated Emissions were performed at the Ultratech's 3 Meter Open Field Test Site (OFTS) situated in the Town of Oakville, province of Ontario.

The above sites have been calibrated in accordance with ANSI C63.4, and found to be in compliance with the requirements of Sec. 2.948 of the FCC Rules. The descriptions and site measurement data of the Oakville Open Field Test Site has been filed with FCC office (FCC File No.: 31040/SIT 1300B3) and Industry Canada office (Industry Canada File No.: IC2049). Last Date of Site Calibration: Nov. 04, 2002.

5.2. APPLICABILITY & SUMMARY OF EMC EMISSION TEST RESULTS

FCC PARAGRAPH.	TEST REQUIREMENTS	COMPLIANCE (YES/NO)
15.107(a) & 207	AC Power Conducted Emissions	N/A for battery operated device
15.247(a)(2)	6dB Bandwidth of a Digital Modulation System	Yes
15.247(b) & 1.1310	Maximum Peak Power (Conducted)	Yes
1.1307, 1.1310, 2.1091 & 2.1093	RF Exposure Limit	Yes
15.247(c)	RF Conducted Spurious Emissions at the Transmitter Antenna Terminal	Yes
15.247(d)	Transmitted Power Density of a Digital Modulation System	Yes
15.247(c), 15.209 & 15.205	Transmitter Radiated Emissions	Yes
FCC Part 15, Sub. B, Sec. 15.109	Class B Radiated Emissions	Yes. Note 1

Note 1: A separate engineering test report for compliance with FCC Part 15, Subpart B - Class B Unintentional Radiators will be provided upon request.

5.3. MODIFICATIONS INCORPORATED IN THE EUT FOR COMPLIANCE PURPOSES

None

ULTRATECH GROUP OF LABS

3000 Bristol Circle, Oakville, Ontario, Canada L6H 6G4
 Tel. #: 905-829-1570, Fax. #: 905-829-8050, Email: vic@ultratech-labs.com, Website: <http://www.ultratech-labs.com>

File #: TEK-434FCC15C

Jan. 19, 2004

- All test results contained in this engineering test report are traceable to National Institute of Standards and Technology (NIST)

EXHIBIT 6. MEASUREMENTS, EXAMINATIONS & TEST DATA FOR EMC EMISSIONS

6.1. TEST PROCEDURES

This section contains test results only. Details of test methods and procedures can be found in Exhibit 8 of this report and ANSI C63-4:1992

6.2. MEASUREMENT UNCERTAINTIES

The measurement uncertainties stated were calculated in accordance with requirements of UKAS Document NIS 81 with a confidence level of 95%. Please refer to Exhibit 7 for Measurement Uncertainties.

6.3. MEASUREMENT EQUIPMENT USED:

The measurement equipment used complied with the requirements of the Standards referenced in the Methods & Procedures ANSI C64-3:1992, FCC 15.247 and CISPR 16-1.

6.4. ESSENTIAL/PRIMARY FUNCTIONS AS DECLARED BY THE MANUFACTURER:

The essential function of the EUT is to correctly communicate data to and from radios over RF link.

6.5. COMPLIANCE WITH FCC PART 15 – GENERAL TECHNICAL REQUIREMENTS

FCC Section	FCC Rules	
15.203	<p>Described how the EUT complies with the requirement that either its antenna is permanently attached, or that it employs a unique antenna connector, for every antenna proposed for use with the EUT.</p> <p>The exception is in those cases where EUT must be professionally installed. In order to demonstrate that professional installation is required, the following 3 points must be addressed:</p> <ul style="list-style-type: none">• The application (or intended use) of the EUT• The installation requirements of the EUT• The method by which the EUT will be marketed	Complies
15.204	<p>Provided the information for every antenna proposed for use with the EUT:</p> <p>(a) type (e.g. Yagi, patch, grid, dish, etc...), (b) manufacturer and model number (c) gain with reference to an isotropic radiator</p>	Complies

6.6. 6 DB BANDWIDTH @ FCC 15.247(A)(2)

6.6.1. Limits

For a Digital Modulation System, the minimum 6 dB bandwidth shall be at least 500 KHz.

6.6.2. Method of Measurements

Refer to ANSI C63-4:1992

The transmitter output was connected to the spectrum analyzer through an attenuator. the bandwidth of the fundamental frequency was measured with the spectrum analyzer using 30 KHz RBW, VBW = 100 KHz,. The 6 dB bandwidth was measured and recorded.

6.6.3. Test Arrangement

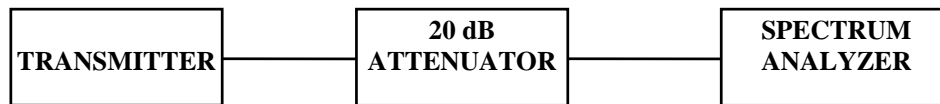

6.6.4. Test Equipment List

Test Instruments	Manufacturer	Model No.	Serial No.	Frequency Range
Spectrum Analyzer/ EMI Receiver	Hewlett Packard	HP 8593EM	3412A00103	9 kHz – 26.5 GHz

6.6.5. Test Data

CHANNEL FREQUENCY (MHz)	Modulation *	6 dB BANDWIDTH (MHz)	MINIMUM LIMIT (MHz)	PASS/FAIL
2412	CCK 11 Mb/s	9.93	0.5	PASS
2437	CCK 11 Mb/s	9.93	0.5	PASS
2462	CCK 11 Mb/s	9.93	0.5	PASS

* Please refer to Plots # 1 to 3 for detailed measurements.

Remarks: The above measurements were found to be the same for all different modulations such as below:

- DBPSK for 1Mb/s Data Rate
- DQPSK for 2 Mb/s Data Rate
- CCK for 5.5 Mb/s Data Rate
- CCK for 11 Mb/s Data Rate

Plot #1: 6 dB Bandwidth @ Frequency: 2412 MHz

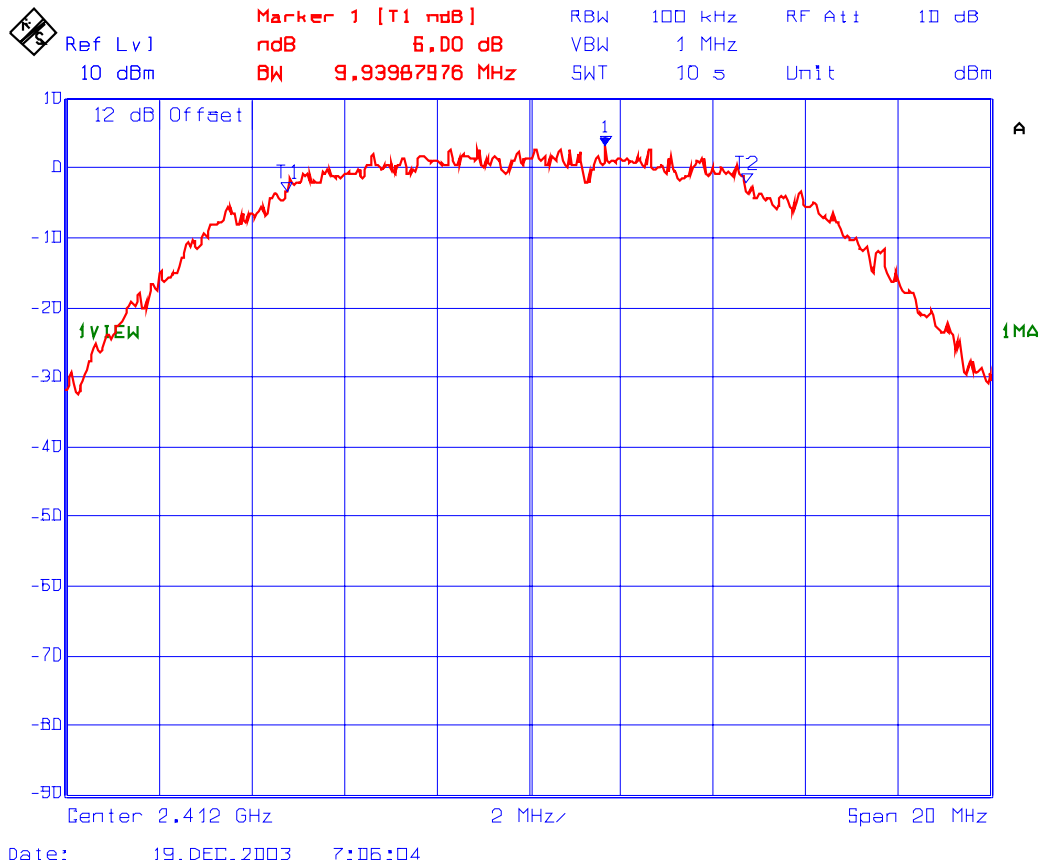

Plot #2: 6 dB Bandwidth @ Frequency: 2437 MHz

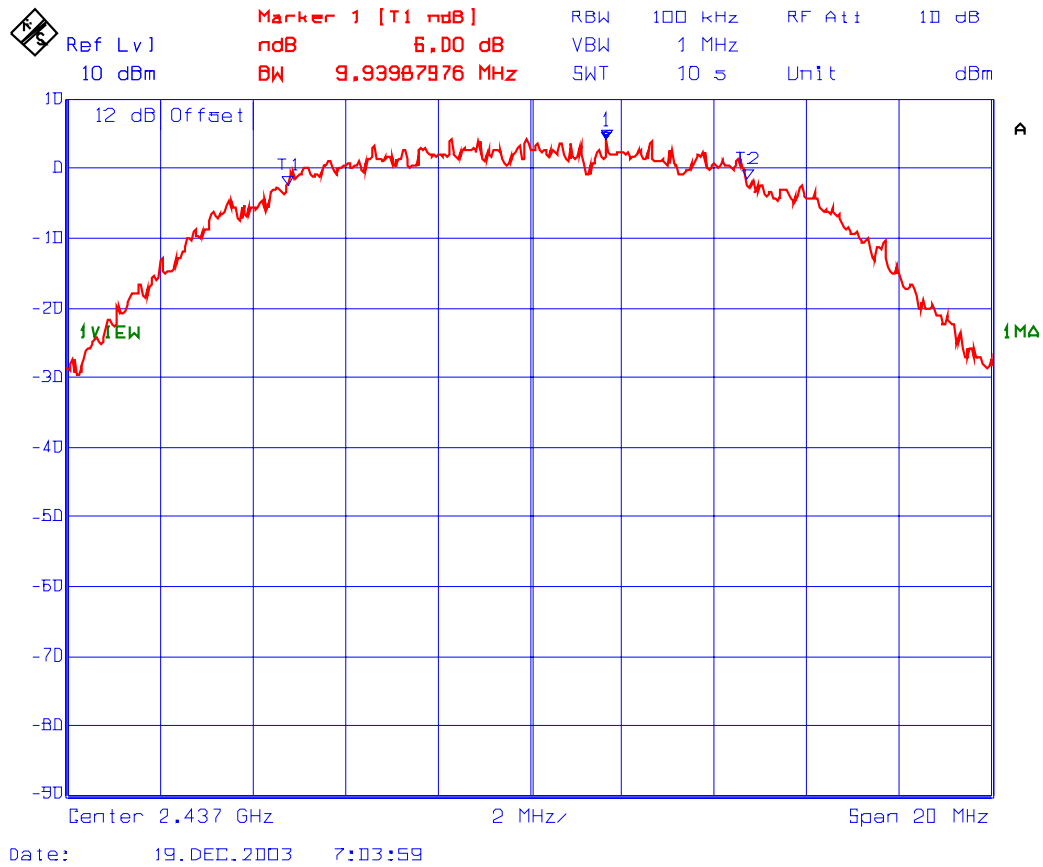

ULTRATECH GROUP OF LABS

3000 Bristol Circle, Oakville, Ontario, Canada L6H 6G4
Tel. #: 905-829-1570, Fax. #: 905-829-8050, Email: vic@ultratech-labs.com, Website: http://www.ultratech-labs.com

File #: TEK-434FCC15C
Jan. 19, 2004

- All test results contained in this engineering test report are traceable to National Institute of Standards and Technology (NIST)

Plot #3: 6 dB Bandwidth @ Frequency: 2462 MHz

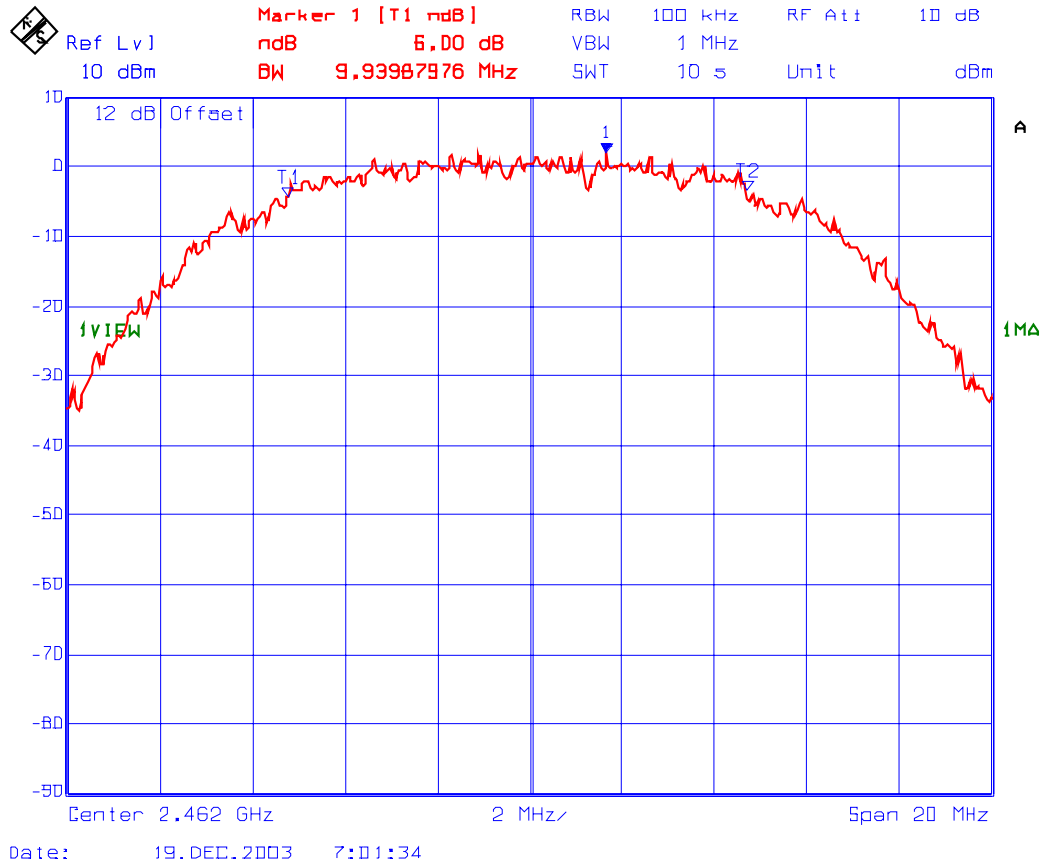

ULTRATECH GROUP OF LABS

3000 Bristol Circle, Oakville, Ontario, Canada L6H 6G4
Tel. #: 905-829-1570, Fax. #: 905-829-8050, Email: vic@ultratech-labs.com, Website: <http://www.ultratech-labs.com>

File #: TEK-434FCC15C
Jan. 19, 2004

- All test results contained in this engineering test report are traceable to National Institute of Standards and Technology (NIST)

6.7. PEAK OUTPUT POWER (CONDUCTED) @ FCC 15.247(B)

6.7.1. Limits

- **FCC 15.247(b)(3):** Maximum peak output power of the transmitter shall not exceed 1 Watt.
- **FCC 15.247(b)(4)(i):** If the device is not for fixed point to point radio, the antenna of directional gain greater than 6 dBi are used, the power shall be reduced by the amount in dB that the directional gain of the antenna exceeds 6 dBi.

6.7.2. Method of Measurements & Test Arrangement

Refer to Exhibit 8, Sec. 8.3 of this test report, FCC 15.247(b)(1)&(3), ANSI C63-4:1992 & ETSI 300 328

Note: The conducted peak power measurement method was performed in accordance with ETSI 300 328 since it was proven to be independent with the peak power meter characteristics.

6.7.3. Test Equipment List

Test Instruments	Manufacturer	Model No.	Serial No.	Frequency Range
Spectrum Analyzer/ EMI Receiver	Hewlett Packard	HP 8546A	...	9 kHz to 5.6 GHz with built-in 30 dB Gain Pre- selector, QP, Average & Peak Detectors.
67297 RF Detector (Diode Detector)	Herotex	DZ122-553	63400	..
Storage Oscilloscope	Philips	PM3320A	ST9907959	--

6.7.4. Test Data

Transmitter Channel	Frequency (MHz)	(full bandwidth) Peak Power at Antenna Terminals (dBm)	Maximum Antenna Gain (dBi)	(full bandwidth) Peak EIRP (dBm)	Limit for Power at Antenna Port (dBm)	Limit for EIRP (dBm)
Lowest	2412	14.6	0	14.6	30.0	36.0
Middle	2437	15.6	0	15.6	30.0	36.0
Highest	2462	13.8	0	13.8	30.0	36.0

Remarks: The above measurements were found to be the same for all different modulations such as below:

- DBPSK for 1Mb/s Data Rate
- DQPSK for 2 Mb/s Data Rate
- CCK for 5.5 Mb/s Data Rate
- CCK for 11 Mb/s Data Rate

6.8. RF EXPOSURE REQUIREMENTS @ FCC 15.247(B)(4), 1.1310 & 2.1091

Evaluation of RF Exposure Compliance Requirements	
RF Exposure Requirements	Compliance with FCC Rules
SAR Tests for Portable Transmitters <ul style="list-style-type: none">Body Tissue	<ul style="list-style-type: none">Not applicable for non-portable transmitter / Comply with SAR limits with body tissue, please refer to SAR test report with maximum SAR level of 0.77 W/Kg.

6.9. TRANSMITTER BAND-EDGE & SPURIOUS EMISSIONS (CONDUCTED), FCC CFR 47, PARA. 15.247(C)

6.9.1. Limits

In any 100 KHz bandwidth outside the operating frequency band, the radio frequency power that is produced by modulation products of the spreading sequence, the information sequence and the carrier frequency shall be at least 20 dB below that in any 100 KHz bandwidth within the band that contains the highest level of the desired power.

6.9.2. Method of Measurements

Refer to Exhibit 8, Sec. 8.4 of this test report, FCC 15.247(c) & ANSI C63-4:1992

6.9.3. Test Arrangement

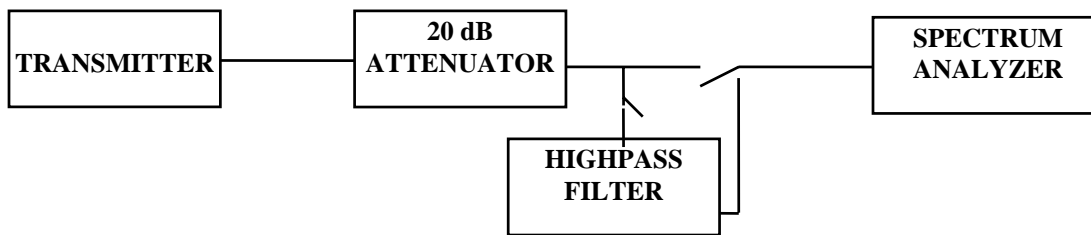

6.9.4. Test Equipment List

Test Instruments	Manufacturer	Model No.	Serial No.	Frequency Range
Spectrum Analyzer/ EMI Receiver	Hewlett Packard	HP 8593EM	3412A00103	9 kHz – 26.5 GHz

6.9.5. Test Data

Remark: Since the RF signal output are exactly identical with different modulations based on our prescans and IEEE 802.1 standard for DSSS, the CCK with 11 Mb/s data rate was chosen for the final tests.

6.9.5.1. Emissions at the band-edges of the FCC Permitted Band

Please refer to Plots # 4 and 5 for detailed measurements of Band-edge emissions at lower and upper permitted band.

Plot #4: Conducted RF Spurious Emissions at Lower Band-Edge Lowest Carrier Frequency: 2412 MHz

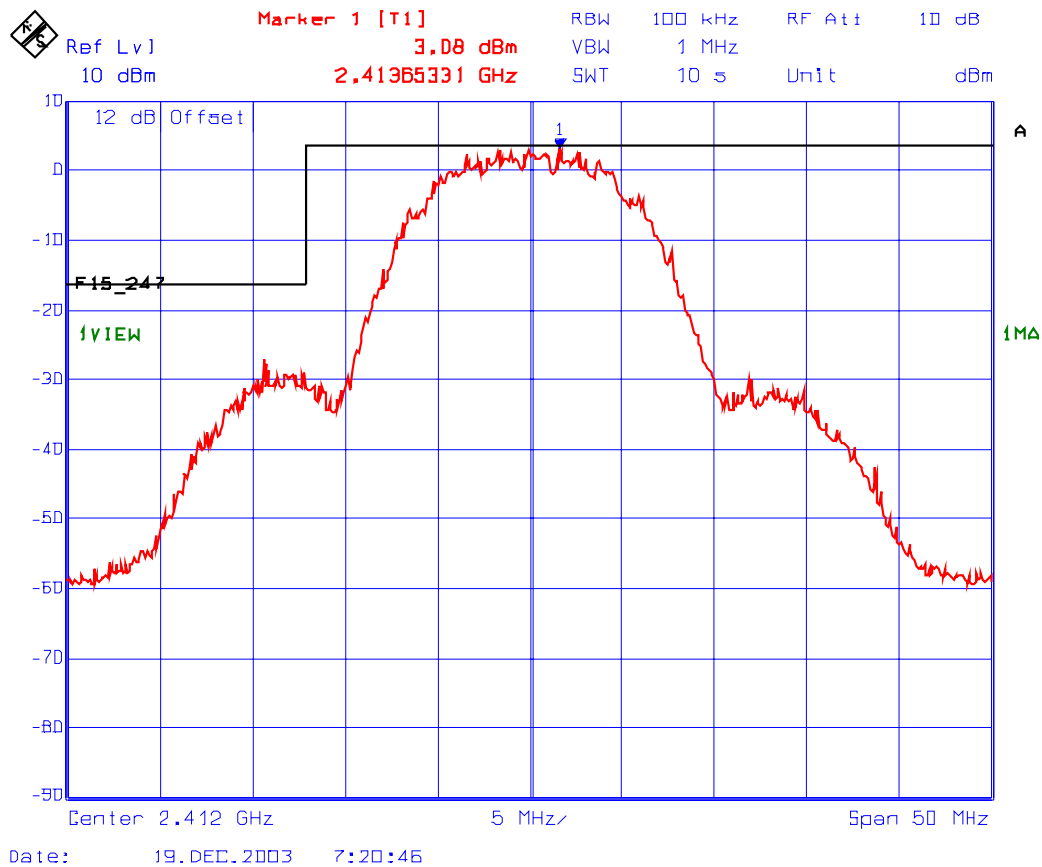

**Plot #5: Conducted RF Spurious Emissions at Lower Band-Edge
Highest Carrier Frequency: 2462 MHz**

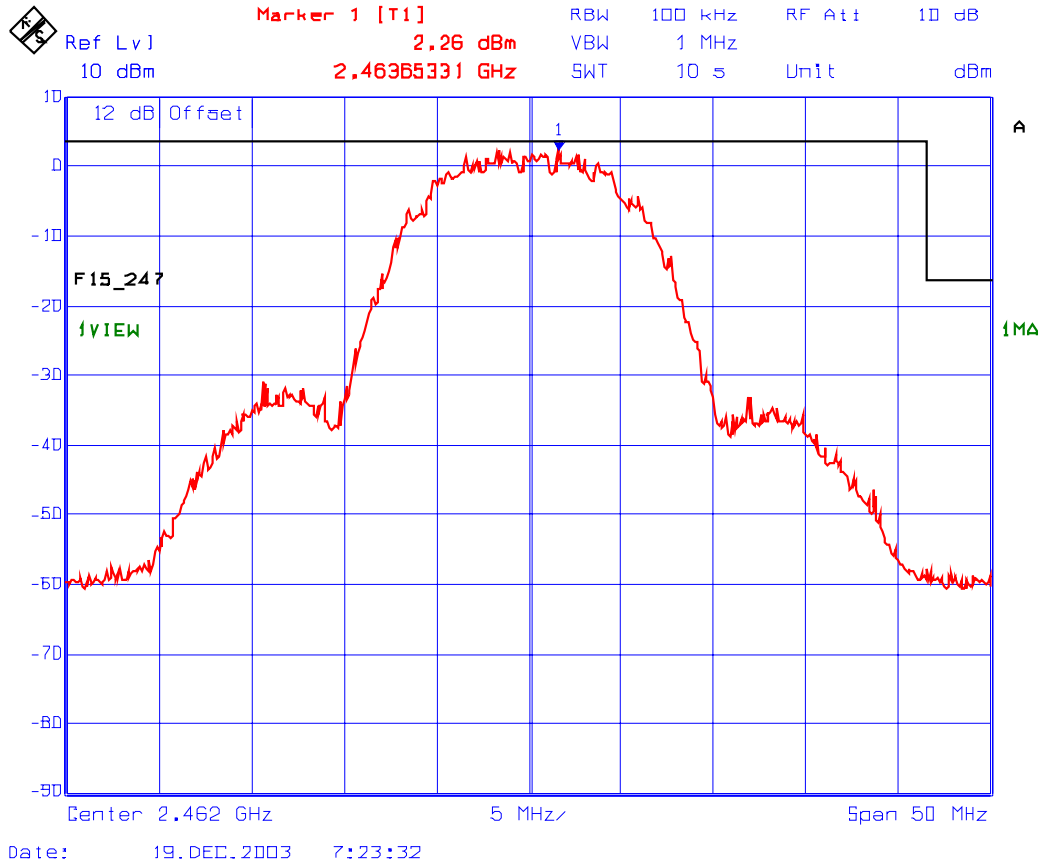

6.9.5.2. Tx Conducted Emissions at Lowest Frequency (xxx MHz)

- The emissions were scanned from 10 MHz to 25 GHz . All spurious emissions were found to be more than 30 dB below FCC Limit.
- Refer to Plots # 6 and 7 for detailed measurements.

6.9.5.3. Tx Conducted Emissions at Middle Frequency (xxx MHz)

- The emissions were scanned from 10 MHz to 25 GHz . All spurious emissions were found to be more than 30 dB below FCC Limit.
- Refer to Plots # 8 and 9 for detailed measurements.

6.9.5.4. Tx Conducted Emissions at Highest Frequency (xxx MHz)

- The emissions were scanned from 10 MHz to 25 GHz . All spurious emissions were found to be more than 30 dB below FCC Limit.
- Refer to Plots # 10 and 11 for detailed measurements.

Plot #6: Conducted RF Spurious/Harmonic Emissions
Lowest Carrier Frequency: 2412 MHz

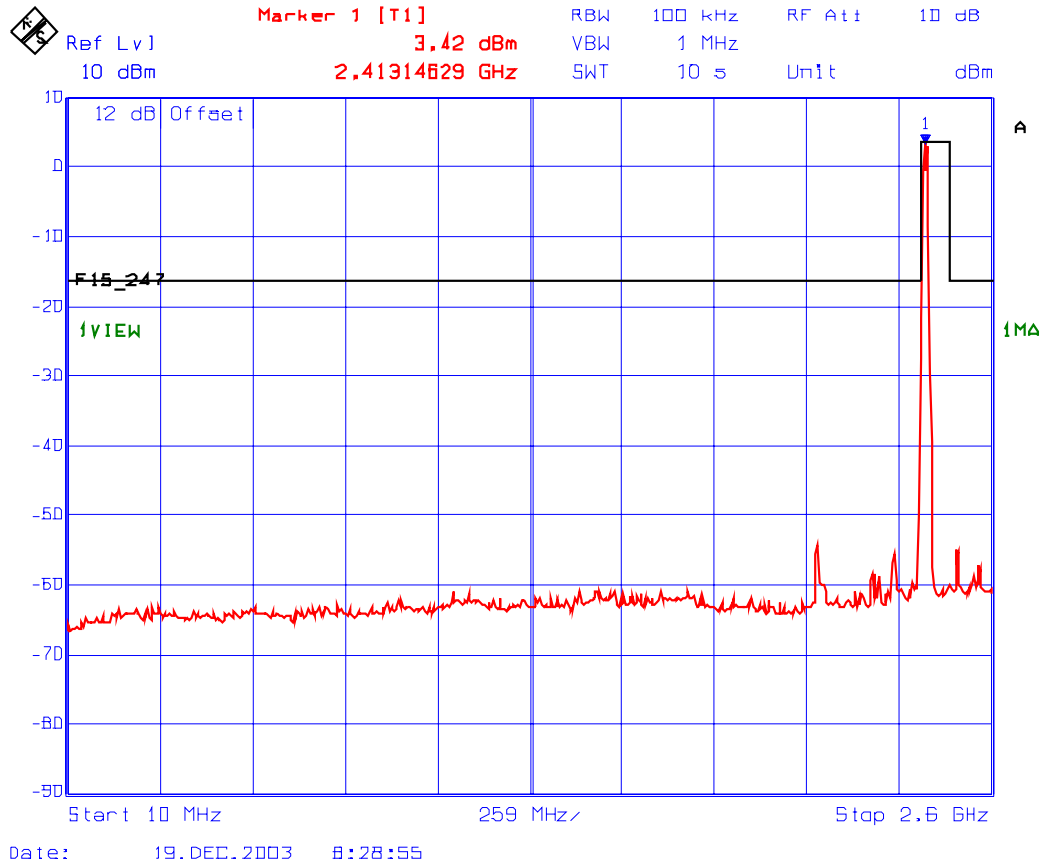

ULTRATECH GROUP OF LABS

3000 Bristol Circle, Oakville, Ontario, Canada L6H 6G4
Tel. #: 905-829-1570, Fax. #: 905-829-8050, Email: vic@ultratech-labs.com, Website: <http://www.ultratech-labs.com>

File #: TEK-434FCC15C
Jan. 19, 2004

- All test results contained in this engineering test report are traceable to National Institute of Standards and Technology (NIST)

Plot #7: Conducted RF Spurious/Harmonic Emissions
Lowest Carrier Frequency: 2412 MHz

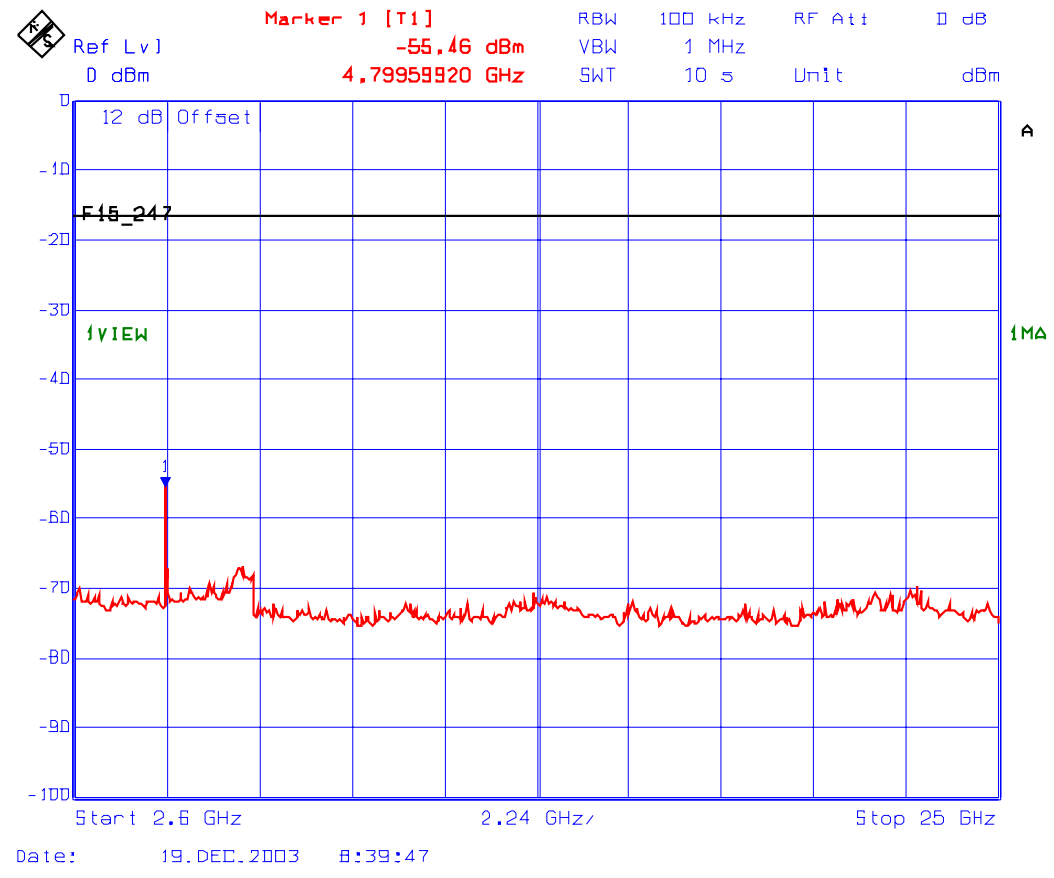

• All test results contained in this engineering test report are traceable to National Institute of Standards and Technology (NIST)

Plot #8: Conducted RF Spurious/Harmonic Emissions
Middle Carrier Frequency: 2437 MHz

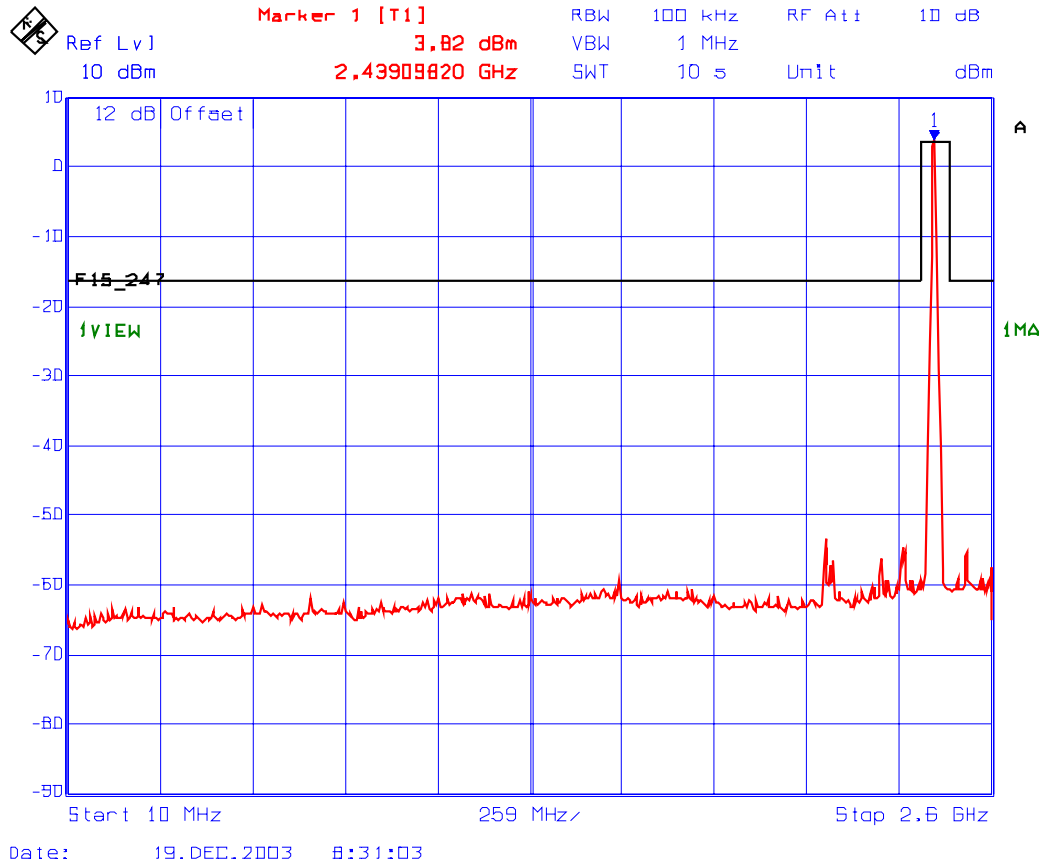

ULTRATECH GROUP OF LABS

3000 Bristol Circle, Oakville, Ontario, Canada L6H 6G4
Tel. #: 905-829-1570, Fax. #: 905-829-8050, Email: vic@ultratech-labs.com, Website: <http://www.ultratech-labs.com>

File #: TEK-434FCC15C
Jan. 19, 2004

- All test results contained in this engineering test report are traceable to National Institute of Standards and Technology (NIST)

Plot #9: Conducted RF Spurious/Harmonic Emissions
Middle Carrier Frequency: 2437 MHz

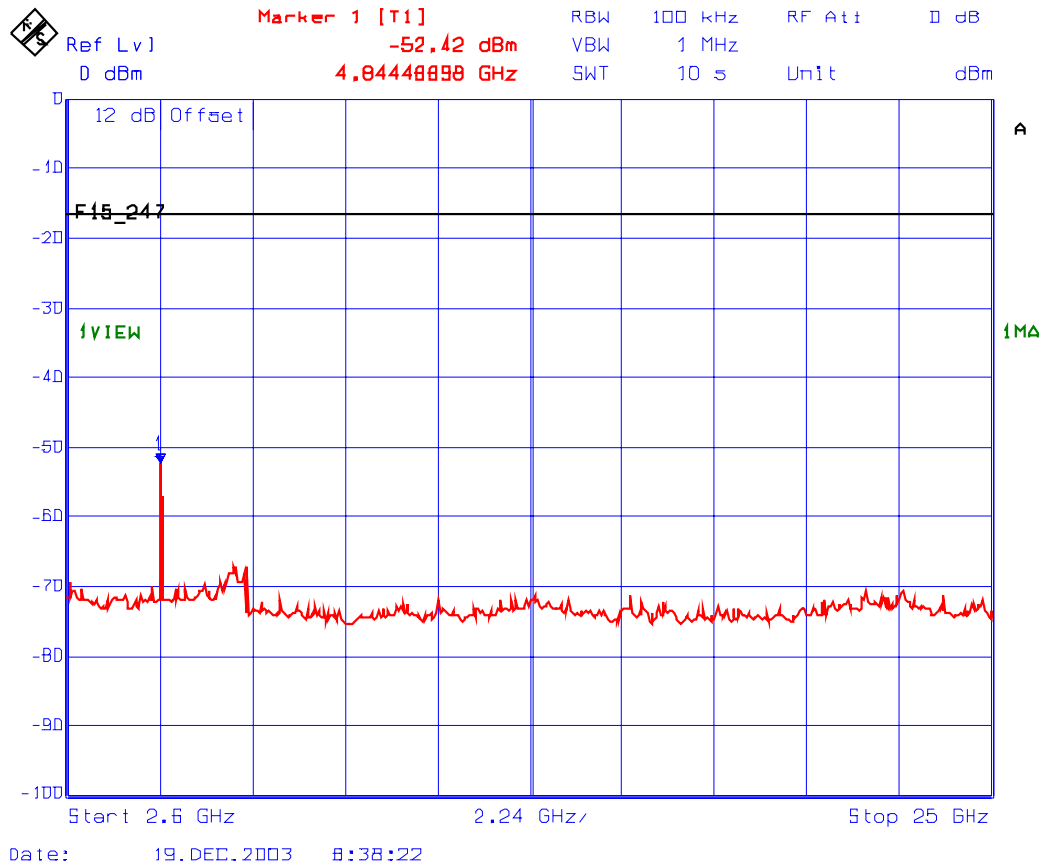

Plot #10: Conducted RF Spurious/Harmonic Emissions Highest Carrier Frequency: 2462 MHz

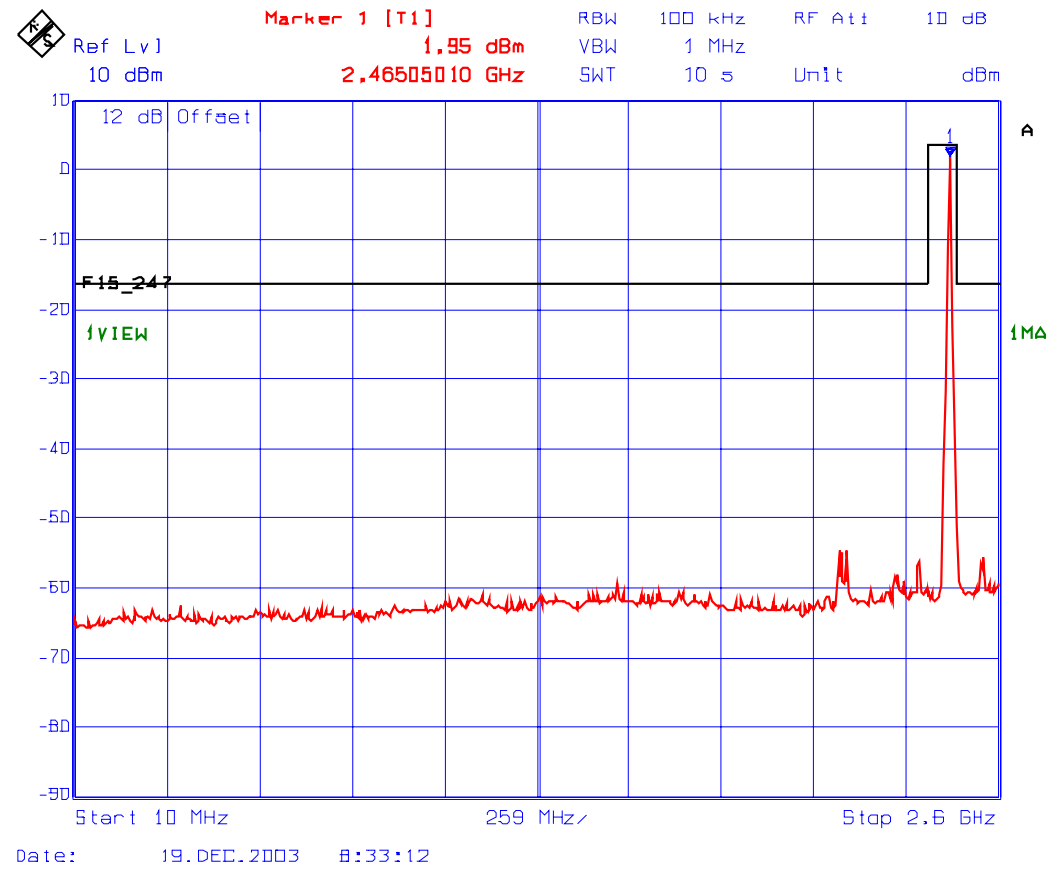

• All test results contained in this engineering test report are traceable to National Institute of Standards and Technology (NIST)

Plot #11: Conducted RF Spurious/Harmonic Emissions Highest Carrier Frequency: 2462 MHz

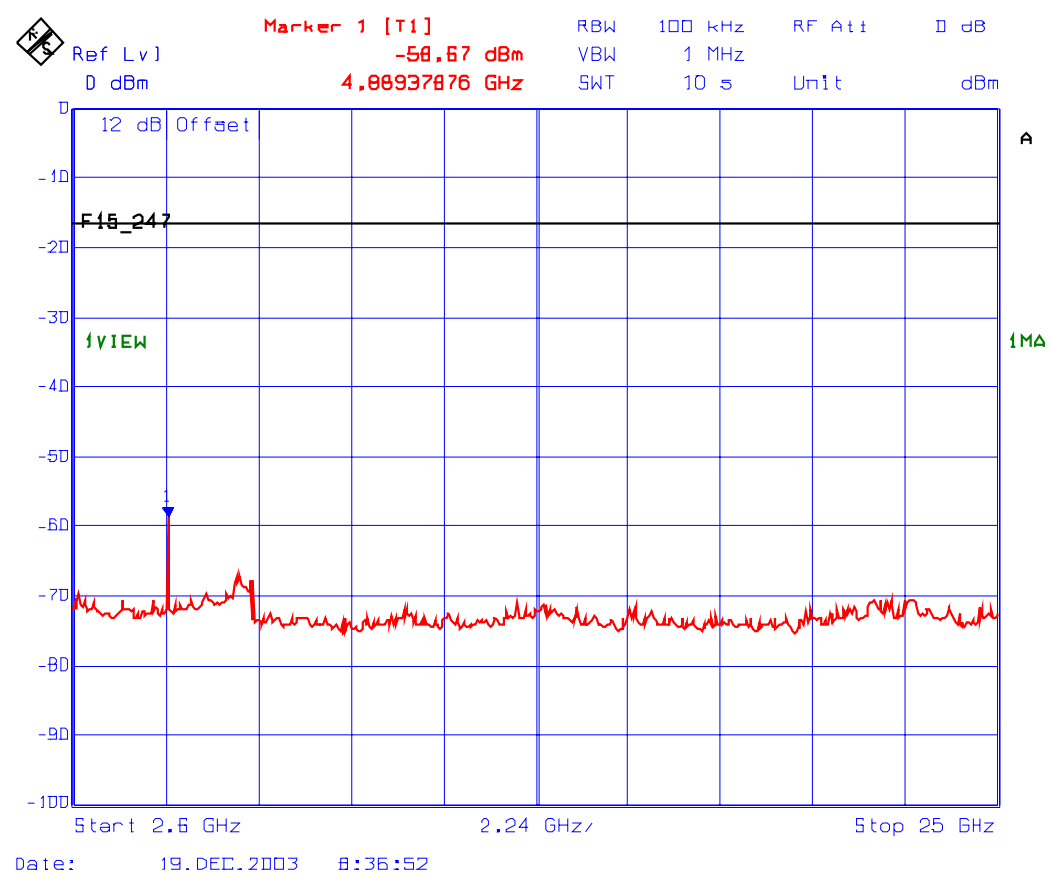

• All test results contained in this engineering test report are traceable to National Institute of Standards and Technology (NIST)

6.10. TRANSMITTED POWER DENSITY OF A DIGITAL MODULATION SYSTEM, FCC CFR 47, PARA. 15.247(D)

6.10.1. Limits

For a direct sequence system, the transmitted power density average over any 1 second interval shall not be greater than 8 dBm in any 3 KHz bandwidth within this band.

6.10.2. Method of Measurements

Refer to Exhibit 8, Sec. 8.5 of this test report for detailed measurement procedures

6.10.3. Test Arrangement

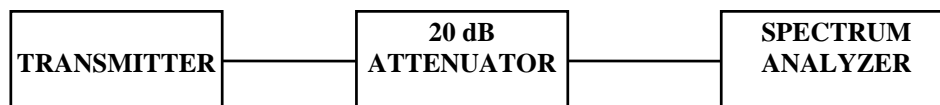

6.10.4. Test Equipment List

Test Instruments	Manufacturer	Model No.	Serial No.	Frequency Range
Spectrum Analyzer/ EMI Receiver	Hewlett Packard	HP 8593EM	3412A00103	9 kHz – 26.5 GHz

6.10.5. Test Data

CHANNEL FREQUENCY (MHz)	MODULATION DATA RATE	RF POWER LEVEL IN 3 KHz BW (dBm)	LIMIT (dBm)	MARGIN (dB)	COMMENTS (PASS/FAIL)
2412	CCK 11 Mbps	-10.1	8.0	-2.1	PASS
2437	CCK 11 Mbps	-10.4	8.0	-2.4	PASS
2462	CCK 11 Mbps	-8.8	8.0	-0.8	PASS

Refer to Plots # 12 to 14 for Measurement Details.

Plot #12: Conducted RF Power Spectral Density
Lowest Carrier Frequency: 2412 MHz

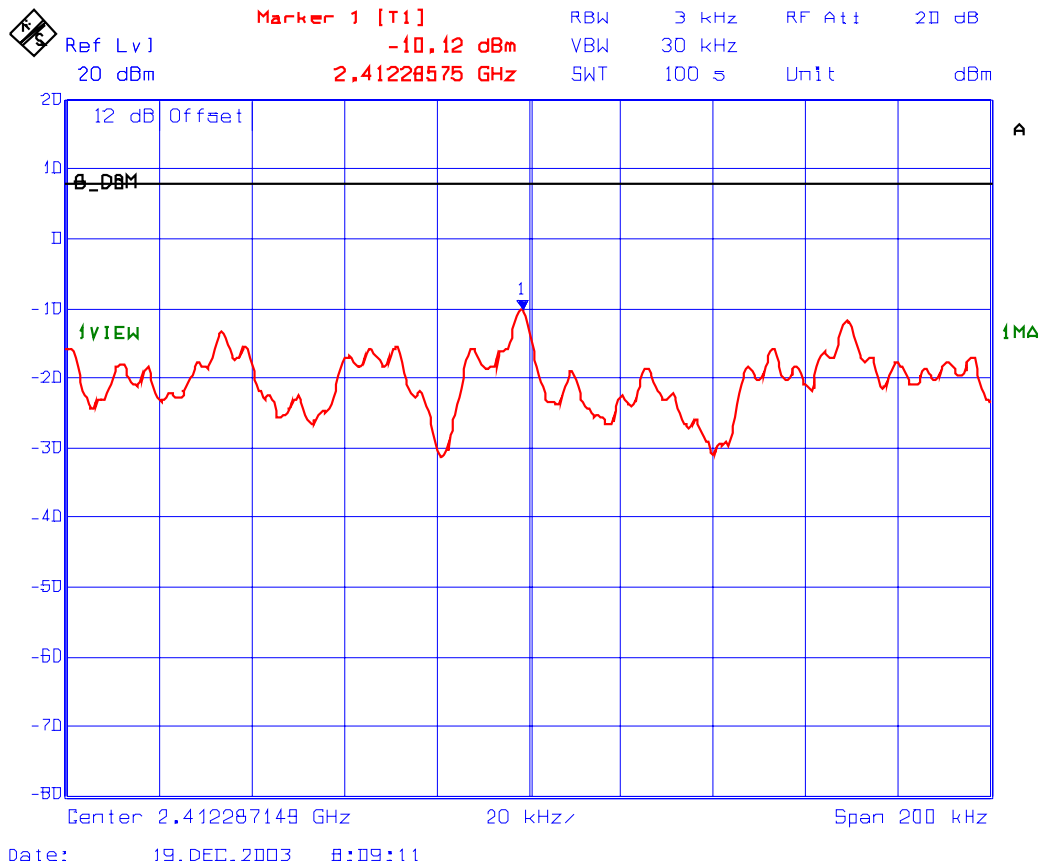

ULTRATECH GROUP OF LABS

3000 Bristol Circle, Oakville, Ontario, Canada L6H 6G4
Tel. #: 905-829-1570, Fax. #: 905-829-8050, Email: vic@ultratech-labs.com, Website: <http://www.ultratech-labs.com>

File #: TEK-434FCC15C
Jan. 19, 2004

- All test results contained in this engineering test report are traceable to National Institute of Standards and Technology (NIST)

Plot #13: Conducted RF Power Spectral Density
Middle Carrier Frequency: 2437 MHz

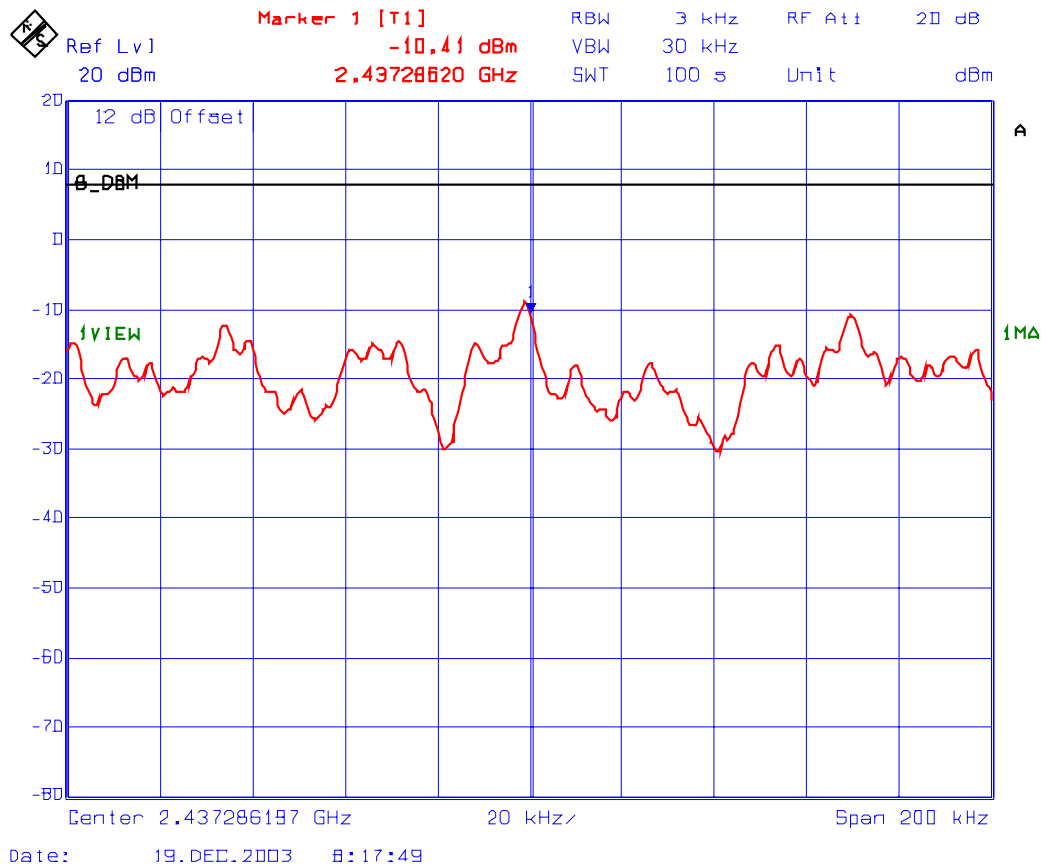

Plot #14: Conducted RF Power Spectral Density Highest Carrier Frequency: 2462 MHz

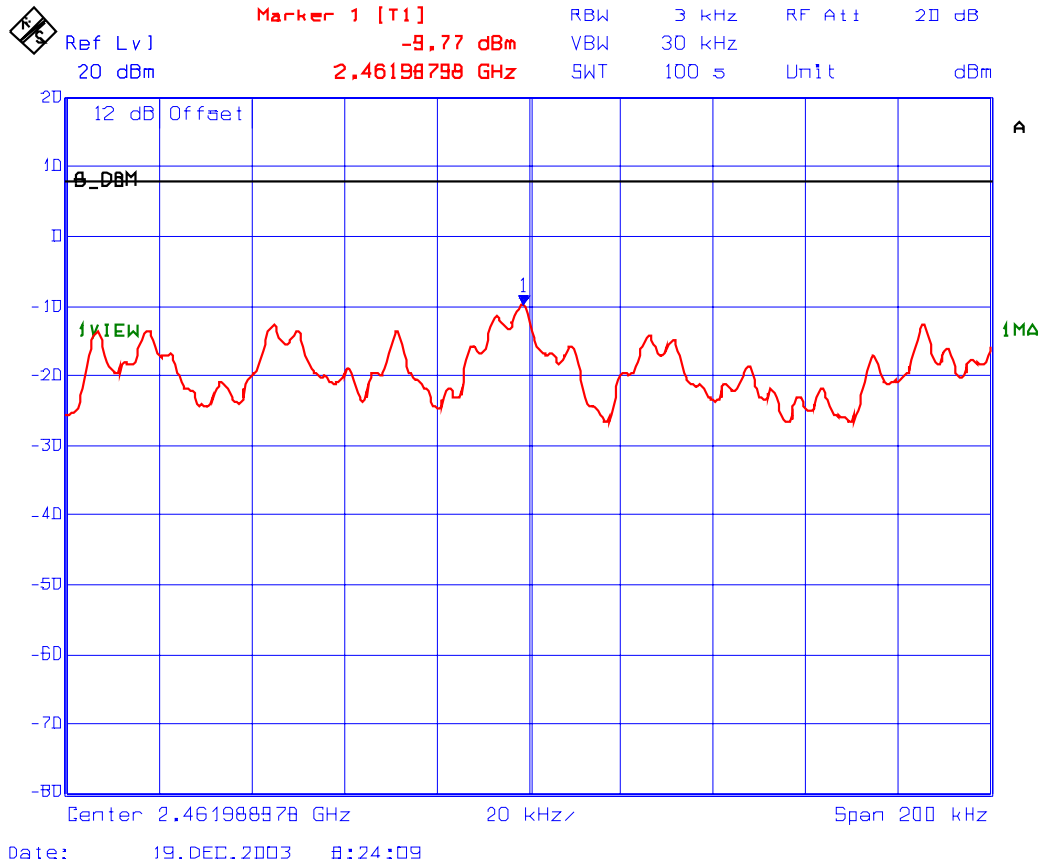

ULTRATECH GROUP OF LABS

3000 Bristol Circle, Oakville, Ontario, Canada L6H 6G4
Tel. #: 905-829-1570, Fax. #: 905-829-8050, Email: vic@ultratech-labs.com, Website: <http://www.ultratech-labs.com>

File #: TEK-434FCC15C
Jan. 19, 2004

- All test results contained in this engineering test report are traceable to National Institute of Standards and Technology (NIST)

6.11. SPURIOUS EMISSIONS (RADIATED @ 3 METERS), FCC CFR 47, PARA. 15.247(C), 15.209 & 15.205

6.11.1. Limits

In any 100 KHz bandwidth outside the operating frequency band, the radio frequency power that is produced by modulation products of the spreading sequence, the information sequence and the carrier frequency shall be either at least 20 dB below that in any 100 KHz bandwidth within the band that contains the highest level of the desired power or shall not exceed the general levels specified in @ 15.209(a), which lesser attenuation.

All other emissions inside restricted bands specified in @ 15.205(a) shall not exceed the general radiated emission limits specified in @ 15.209(a)

Remarks:

- Applies to harmonics/spurious emissions that fall in the restricted bands listed in Section 15.205. The maximum permitted average field strength is listed in Section 15.209.
- @ FCC CFR 47, Para. 15.237(c) - The emission limits as specified above are based on measurement instrument employing an average detector. The provisions in @15.35 for limiting peak emissions apply.

FCC CFR 47, Part 15, Subpart C, Para. 15.205(a) - Restricted Frequency Bands

MHz	MHz	MHz	GHz
0.090 - 0.110	162.0125 - 167.17	2310 - 2390	9.3 - 9.5
0.49 - 0.51	167.72 - 173.2	2483.5 - 2500	10.6 - 12.7
2.1735 - 2.1905	240 - 285	2655 - 2900	13.25 - 13.4
8.362 - 8.366	322 - 335.4	3260 - 3267	14.47 - 14.5
13.36 - 13.41	399.9 - 410	3332 - 3339	14.35 - 16.2
25.5 - 25.67	608 - 614	3345.8 - 3358	17.7 - 21.4
37.5 - 38.25	960 - 1240	3600 - 4400	22.01 - 23.12
73 - 75.4	1300 - 1427	4500 - 5250	23.6 - 24.0
108 - 121.94	1435 - 1626.5	5350 - 5460	31.2 - 31.8
123 - 138	1660 - 1710	7250 - 7750	36.43 - 36.5
149.9 - 150.05	1718.8 - 1722.2	8025 - 8500	Above 38.6
156.7 - 156.9	2200 - 2300	9000 - 9200	

FCC CFR 47, Part 15, Subpart C, Para. 15.209(a)

-- Field Strength Limits within Restricted Frequency Bands --

FREQUENCY (MHz)	FIELD STRENGTH LIMITS (microvolts/m)	DISTANCE (Meters)
0.009 - 0.490	2,400 / F (KHz)	300
0.490 - 1.705	24,000 / F (KHz)	30
1.705 - 30.0	30	30
30 - 88	100	3
88 - 216	150	3
216 - 960	200	3
Above 960	500	3

6.11.2. Method of Measurements

Refer to Exhibit 8, Sec. 8.4 of this test report and ANSI 63.4-1992, Para. 8 for detailed radiated emissions measurement procedures.

The following measurement procedures were also applied:

- Applies to harmonics/spurious that fall in the restricted bands listed in Section 15.205. the maximum permitted average field strength is listed in Section 15.209. A Pre-Amp and highpass filter are used for this measurement.
- For measurement below 1 GHz, set RBW = 100 KHz, VBW \geq 100 KHz, SWEEP=AUTO.
- For measurement above 1 GHz, set RBW = 1 MHz, VBW = 1 MHz (Peak) & VBW = 10 Hz (Average), SWEEP=AUTO.
- If the emission is pulsed, modified the unit for continuous operation, then use the settings above for measurements, then correct the reading by subtracting the peak-average correction factor derived from the appropriate duty cycle calculation. See Section 15.35(b) and (c).

6.11.3. Test Arrangement

Please refer to Test Arrangement in Sec. 5.5.3 for details of test setup for emission measurements.

6.11.4. Test Equipment List

Test Instruments	Manufacturer	Model No.	Serial No.	Frequency Range
Spectrum Analyzer/ EMI Receiver	Advantest	R3271	15050203	100 Hz to 32 GHz with external mixer for frequency above 32 GHz
Microwave Amplifier	Hewlett Packard	HP 83017A		1 GHz to 26.5 GHz
Biconilog Antenna	EMCO	3143	1029	20 MHz to 2 GHz
Horn Antenna	EMCO	3155	9701-5061	1 GHz – 18 GHz
Highpass Filter	K&L	11SH10-1500-T8000	--	Cut-off at 1500 MHz used for 902-928 MHz Radio
Highpass Filter	Michael Lab	XD40N	--	Cut-off at 4 GHz used for 2.4-2.4835 GHz

6.11.5. Photographs of Test Setup

Refer to the Photographs #1 to 3 in Annex 1 for setup and arrangement of equipment under tests and its ancillary equipment.

6.11.6. Test Data

Remark: Since the RF signal output are exactly identical with different modulations based on our prescans and IEEE 802.1 standard for DSSS, the CCK with 11 Mb/s data rate was chosen for the final tests.

6.11.6.1. Transmitter Spurious Emissions Measurements with Psion Teklogix Antenna, Model No.: 1020096-100, Gain: 0 dBi.

6.11.6.1.1. Lowest Frequency (2412 MHz)

Frequency (MHz)	RF Peak Level (dBµV/m)	RF Avg Level (dBµV/m)	Antenna Plane (H/V)	Limit 15.209 (dBµV/m)	Limit 15.247 (dBµV/m)	Margin (dB)	Pass/Fail
2412.00	108.8	--	V	--	--	--	PASS
2412.00	110.9	--	H	--	--	--	PASS
4824.00	44.7	40.4	V	54.0	90.3	-13.6	*PASS
4824.00	43.4	38.5	H	54.0	90.3	-15.5	*PASS
<ul style="list-style-type: none"> The emissions were scanned from 10 MHz to 25 GHz and all emissions less 20 dB below the limits were recorded. Please refer to Plot # 15 and 16 for Band-Edge Radiated Emissions measured at 3 meters. 							

* Frequency in restricted bands, therefore FCC 15.209 limit applied.

6.11.6.1.2. Middle Frequency (2437 MHz)

Frequency (MHz)	RF Peak Level (dBµV/m)	RF Avg Level (dBµV/m)	Antenna Plane (H/V)	Limit 15.209 (dBµV/m)	Limit 15.247 (dBµV/m)	Margin (dB)	Pass/Fail
2437.00	110.5	--	V	--	--	--	PASS
2437.00	112.1	--	H	--	--	--	PASS
4874.00	45.1	40.8	V	54.0	92.1	-13.2	*PASS
4874.00	42.4	34.2	H	54.0	92.1	-19.8	*PASS
The emissions were scanned from 10 MHz to 25 GHz and all emissions less 20 dB below the limits were recorded.							

* Frequency in restricted bands, therefore FCC 15.209 limit applied.

6.11.6.1.3. Highest Frequency (2462 MHz)

Frequency (MHz)	RF Peak Level (dBµV/m)	RF Avg Level (dBµV/m)	Antenna Plane (H/V)	Limit 15.209 (dBµV/m)	Limit 15.247 (dBµV/m)	Margin (dB)	Pass/Fail
2437.00	108.7	--	V	--	--	--	PASS
2437.00	111.7	--	H	--	--	--	PASS
4874.00	46.5	43.3	V	54.0	91.7	-10.7	*PASS
4874.00	45.8	42.1	H	54.0	91.7	-11.9	*PASS
<ul style="list-style-type: none"> The emissions were scanned from 10 MHz to 25 GHz and all emissions less 20 dB below the limits were recorded. Please refer to Plot # 17 and 18 for Band-Edge Radiated Emissions measured at 3 meters. 							

* Frequency in restricted bands, therefore FCC 15.209 limit applied.

Plot #15: Transmitter Band-Edge Radiated Emissions
@ 3 Meters (Horizontal Polarization)
(Psion Teklogix Antenna, Model No.: 1020096-100, Gain: 0 dBi)
Frequency: 2412 MHz, Delta Trace 1 & Trace 2: 7.66 dB
Trace 1: RBW= 1 MHz, VBW= 3 MHz
Trace 2: RBW= 100 kHz, VBW= 1 MHz

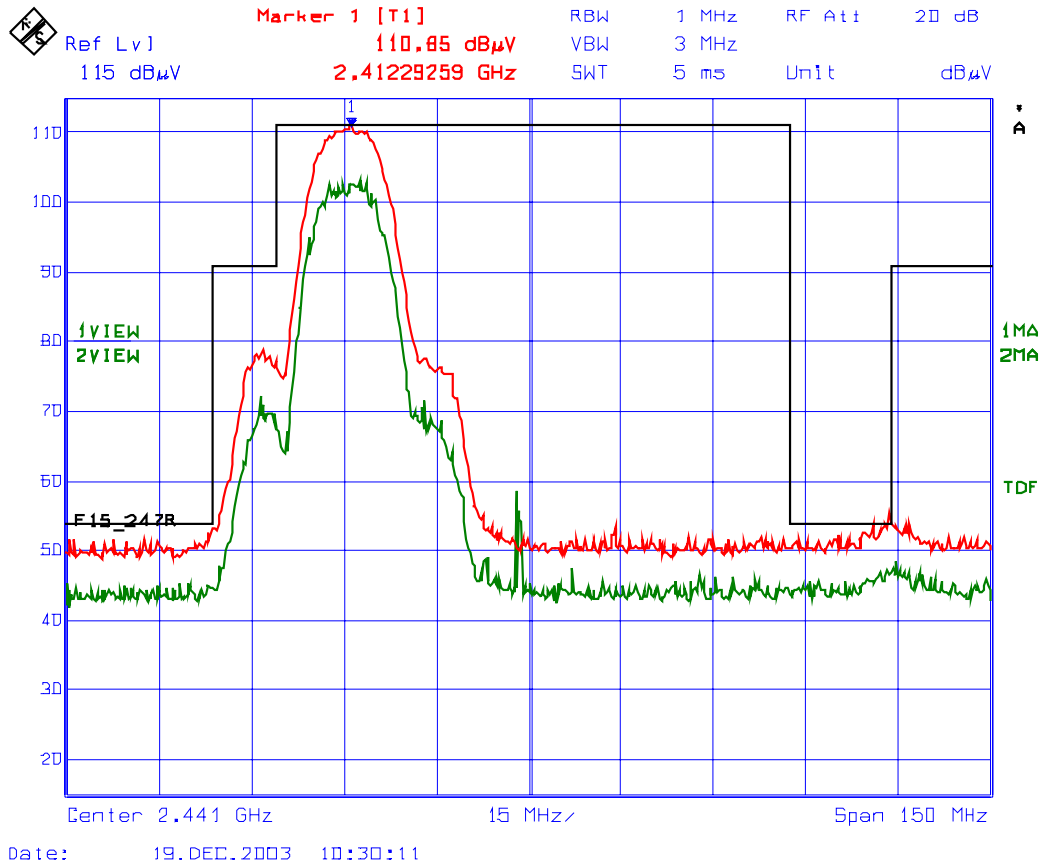

**Plot #16: Transmitter Band-Edge Radiated Emissions
@ 3 Meters (Vertical Polarization)
(Psion Teklogix Antenna, Model No.: 1020096-100, Gain: 0 dBi)**

Frequency: 2412 MHz, Delta Trace 1 & Trace 2: 8.18 dB
Trace 1: RBW= 1 MHz, VBW= 3 MHz
Trace 2: RBW= 100 kHz, VBW= 1 MHz

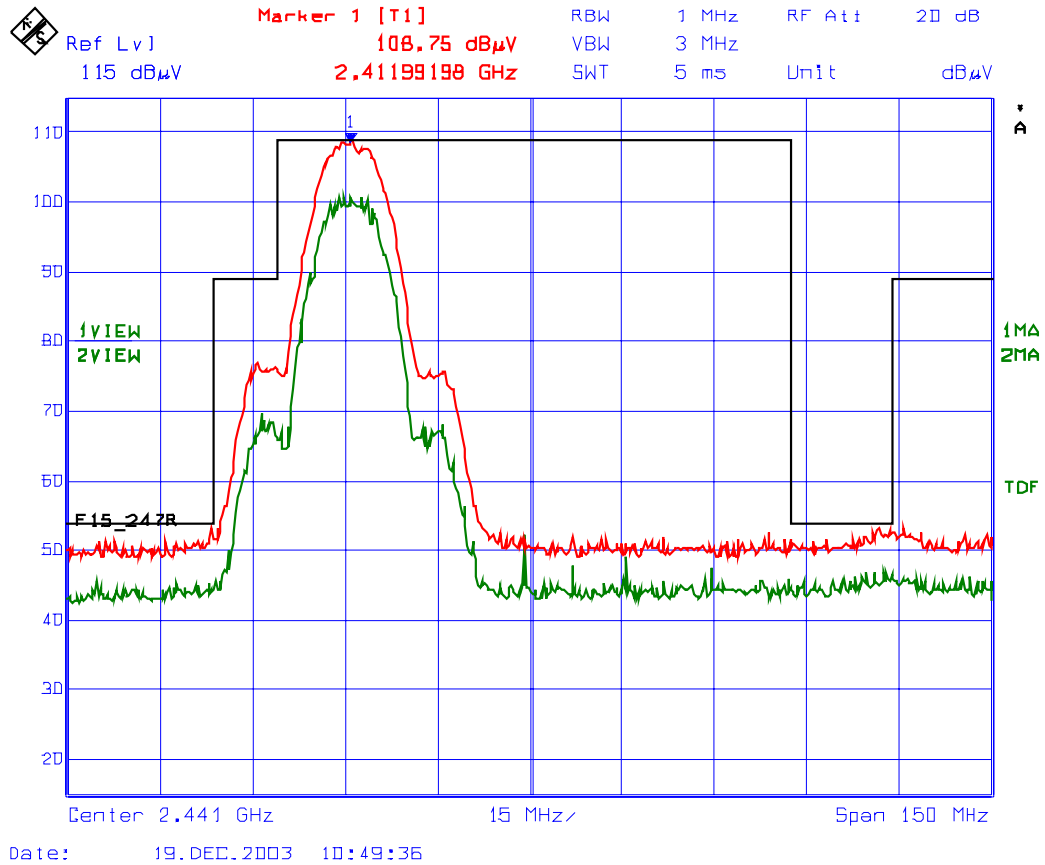

**Plot #17: Transmitter Band-Edge Radiated Emissions
@ 3 Meters (Horizontal Polarization)
(Psion Teklogix Antenna, Model No.: 1020096-100, Gain: 0 dBi)**

Frequency: 2462 MHz, Delta Trace 1 & Trace 2: 7.63 dB
Trace 1: RBW= 1 MHz, VBW= 3 MHz
Trace 2: RBW= 100 kHz, VBW= 1 MHz

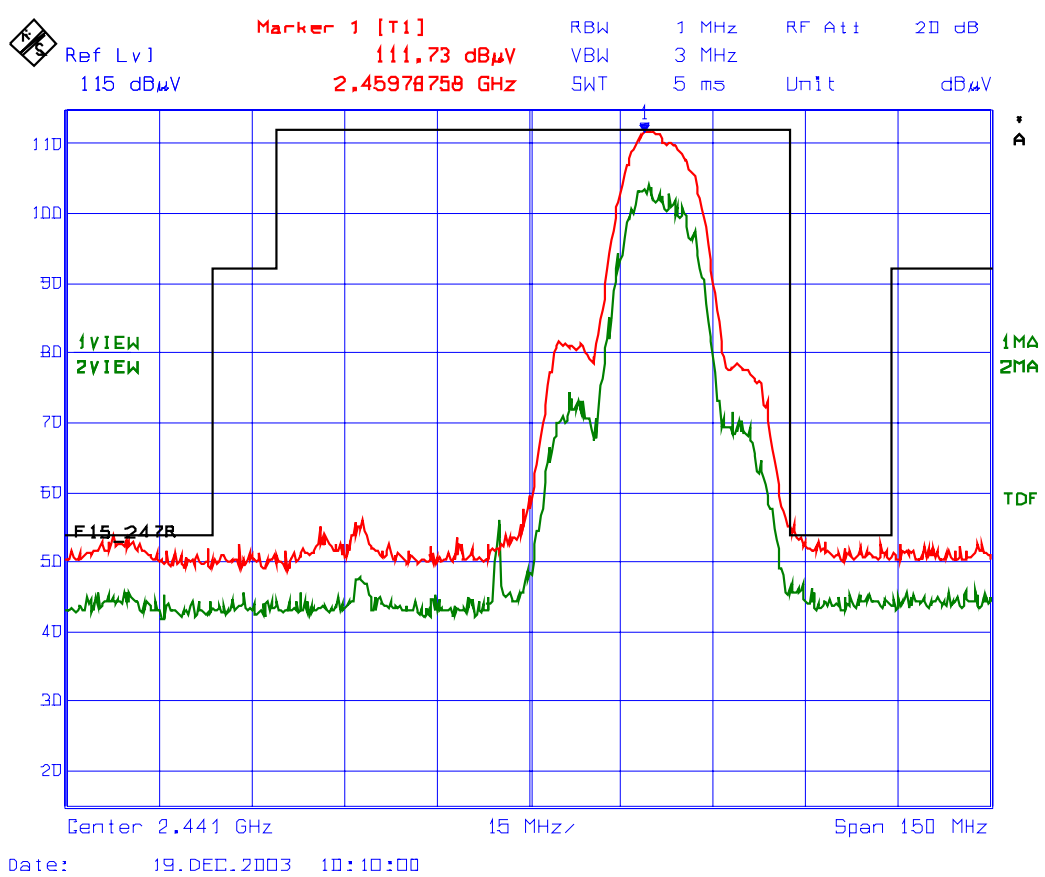

• All test results contained in this engineering test report are traceable to National Institute of Standards and Technology (NIST)

**Plot #18: Transmitter Band-Edge Radiated Emissions
@ 3 Meters (Vertical Polarization)
(Psion Teklogix Antenna, Model No.: 1020096-100, Gain: 0 dBi)**

Frequency: 2462 MHz, Delta Trace 1 & Trace 2: 7.63 dB
Trace 1: RBW= 1 MHz, VBW= 3 MHz
Trace 2: RBW= 100 kHz, VBW= 1 MHz

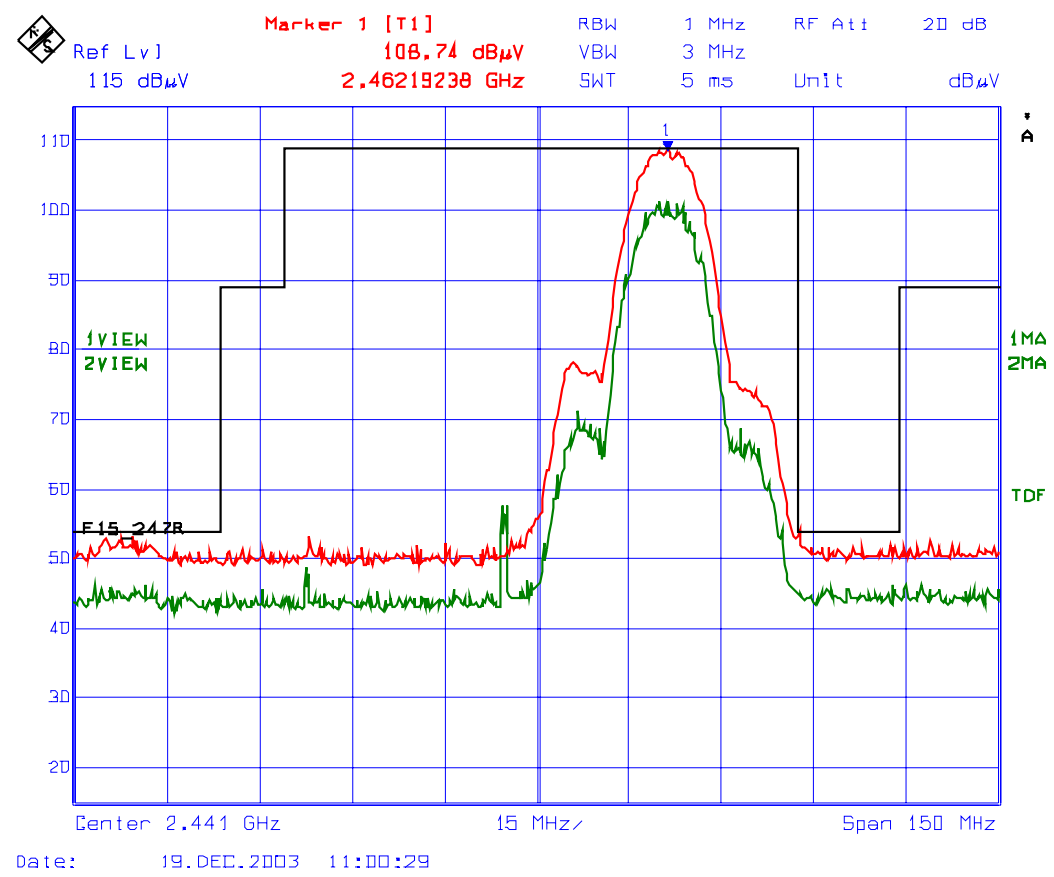

• All test results contained in this engineering test report are traceable to National Institute of Standards and Technology (NIST)

6.11.6.2. Transmitter Spurious Emissions Measurements with Walsin Technology Corporation, Model RFANT 5220110A0T, Gain: 2 dBi.

6.11.6.2.1. Lowest Frequency (2412 MHz)

Frequency (MHz)	RF Peak Level (dBµV/m)	RF Avg Level (dBµV/m)	Antenna Plane (H/V)	Limit 15.209 (dBµV/m)	Limit 15.247 (dBµV/m)	Margin (dB)	Pass/Fail
2412.00	104.6	--	V	--	--	--	PASS
2412.00	106.3	--	H	--	--	--	PASS
4824.00	40.0	30.9	V	54.0	86.3	-23.1	*PASS
4824.00	41.2	34.9	H	54.0	86.3	-19.1	*PASS
<ul style="list-style-type: none"> The emissions were scanned from 10 MHz to 25 GHz and all emissions less 20 dB below the limits were recorded. Please refer to Plot # 19 and 20 for Band-Edge Radiated Emissions measured at 3 meters. 							

* Frequency in restricted bands, therefore FCC 15.209 limit applied.

6.11.6.2.2. Middle Frequency (2437 MHz)

Frequency (MHz)	RF Peak Level (dBµV/m)	RF Avg Level (dBµV/m)	Antenna Plane (H/V)	Limit 15.209 (dBµV/m)	Limit 15.247 (dBµV/m)	Margin (dB)	Pass/Fail
2437.00	106.2	--	V	--	--	--	PASS
2437.00	108.2	--	H	--	--	--	PASS
4874.00	40.2	31.1	V	54.0	88.2	-22.9	*PASS
4874.00	40.2	32.7	H	54.0	88.2	-21.3	*PASS
The emissions were scanned from 10 MHz to 25 GHz and all emissions less 20 dB below the limits were recorded.							

* Frequency in restricted bands, therefore FCC 15.209 limit applied.

6.11.6.2.3. Highest Frequency (2462 MHz)

Frequency (MHz)	RF Peak Level (dBµV/m)	RF Avg Level (dBµV/m)	Antenna Plane (H/V)	Limit 15.209 (dBµV/m)	Limit 15.247 (dBµV/m)	Margin (dB)	Pass/Fail
2437.00	107.9	--	V	--	--	--	PASS
2437.00	107.8	--	H	--	--	--	PASS
4874.00	40.2	31.2	V	54.0	91.7	-22.8	*PASS
4874.00	40.6	31.8	H	54.0	91.7	-22.2	*PASS
<ul style="list-style-type: none"> The emissions were scanned from 10 MHz to 25 GHz and all emissions less 20 dB below the limits were recorded. Please refer to Plot # 21 and 22 for Band-Edge Radiated Emissions measured at 3 meters. 							

* Frequency in restricted bands, therefore FCC 15.209 limit applied.

**Plot # 19: Transmitter Band-Edge Radiated Emissions
@ 3 Meters (Horizontal Polarization)
(Walsin Technology Corporation Monopole Antenna, Model RFANT
5220110A0T, Gain: 2 dBi)
Frequency: 2412 MHz, Delta Trace 1 & Trace 2: 7.55 dB
Trace 1: RBW= 1 MHz, VBW= 3 MHz
Trace 2: RBW= 100 kHz, VBW= 1 MHz**

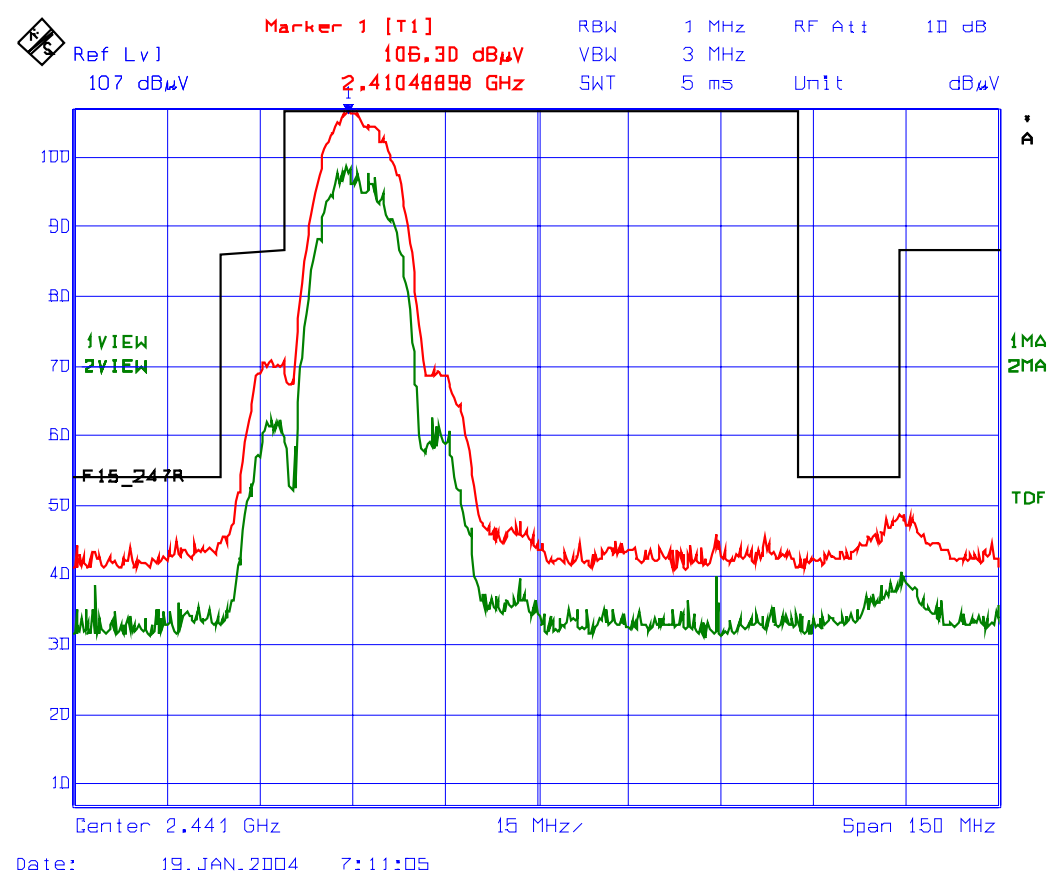

• All test results contained in this engineering test report are traceable to National Institute of Standards and Technology (NIST)

**Plot #20: Transmitter Band-Edge Radiated Emissions
@ 3 Meters (Vertical Polarization)
(Walsin Technology Corporation Monopole Antenna, Model RFANT
5220110A0T, Gain: 2 dBi)
Frequency: 2412 MHz, Delta Trace 1 & Trace 2: 8.61 dB
Trace 1: RBW= 1 MHz, VBW= 3 MHz
Trace 2: RBW= 100 kHz, VBW= 1 MHz**

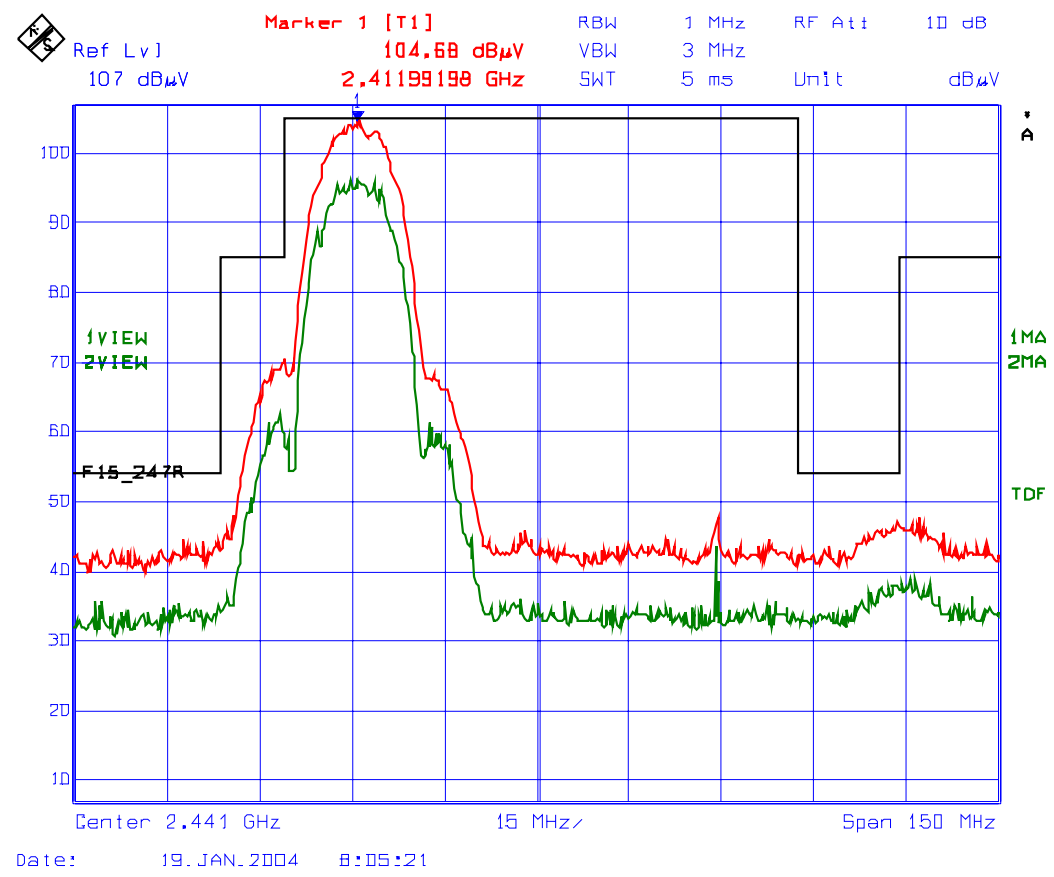

• All test results contained in this engineering test report are traceable to National Institute of Standards and Technology (NIST)

**Plot # 21: Transmitter Band-Edge Radiated Emissions
@ 3 Meters (Horizontal Polarization)
(Walsin Technology Corporation Monopole Antenna, Model RFANT
5220110A0T, Gain: 2 dBi)**

Frequency: 2462 MHz, Delta Trace 1 & Trace 2: 7.88 dB
Trace 1: RBW= 1 MHz, VBW= 3 MHz
Trace 2: RBW= 100 kHz, VBW= 1 MHz

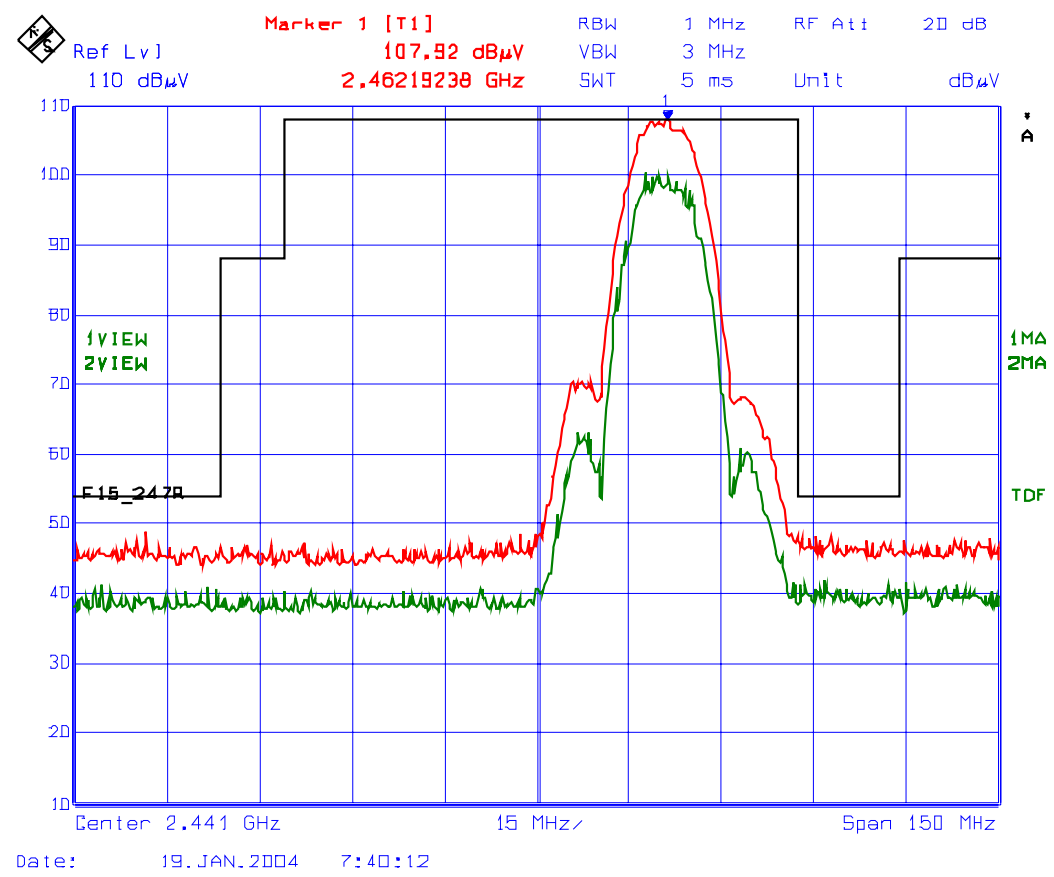

All test results contained in this engineering test report are traceable to National Institute of Standards and Technology (NIST)

**Plot #22: Transmitter Band-Edge Radiated Emissions
@ 3 Meters (Vertical Polarization)
(Walsin Technology Corporation Monopole Antenna, Model RFANT
5220110A0T, Gain: 2 dBi)
Frequency: 2462 MHz, Delta Trace 1 & Trace 2: 8.36 dB
Trace 1: RBW= 1 MHz, VBW= 3 MHz
Trace 2: RBW= 100 kHz, VBW= 1 MHz**

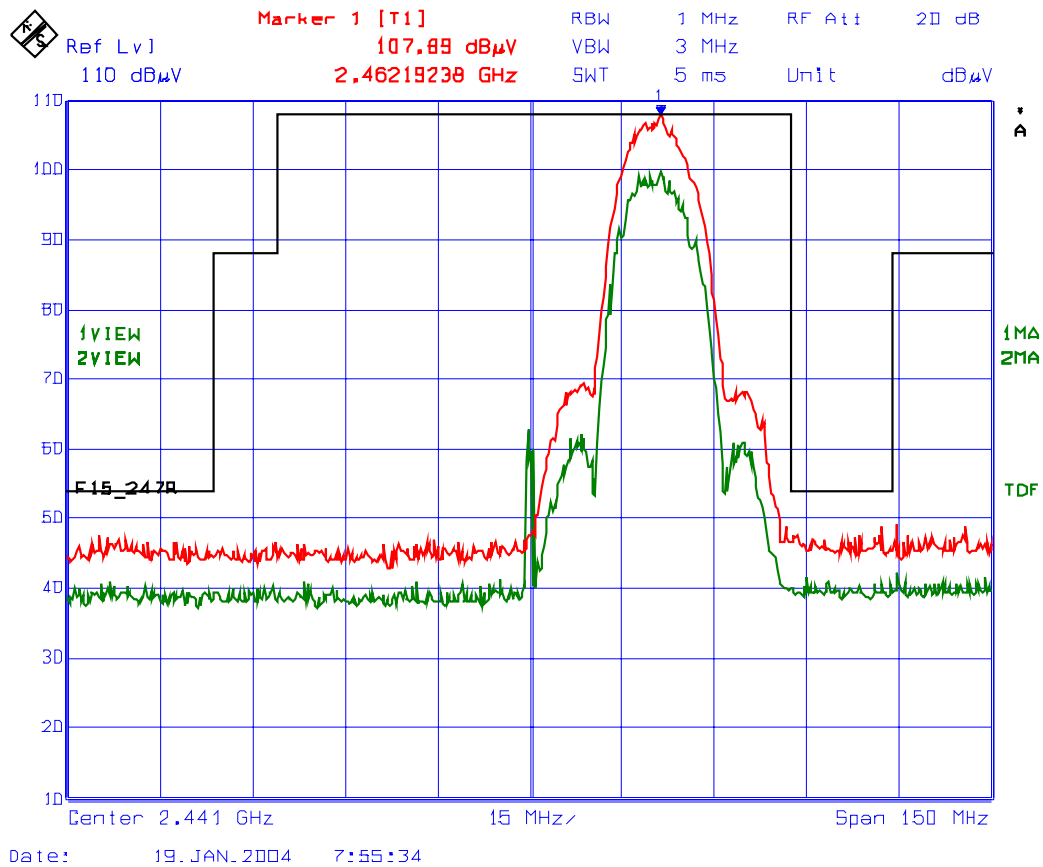

ULTRATECH GROUP OF LABS

3000 Bristol Circle, Oakville, Ontario, Canada L6H 6G4
Tel. #: 905-829-1570, Fax. #: 905-829-8050, Email: vic@ultratech-labs.com, Website: <http://www.ultratech-labs.com>

File #: TEK-434FCC15C
Jan. 19, 2004

- All test results contained in this engineering test report are traceable to National Institute of Standards and Technology (NIST)

EXHIBIT 7. MEASUREMENT UNCERTAINTY

The measurement uncertainties stated were calculated in accordance with the requirements of NIST Technical Note 1297 and NIS 81 (1994)

7.1. LINE CONDUCTED EMISSION MEASUREMENT UNCERTAINTY

CONTRIBUTION (Line Conducted)	PROBABILITY DISTRIBUTION	UNCERTAINTY (dB)	
		9-150 kHz	0.15-30 MHz
EMI Receiver specification	Rectangular	± 1.5	± 1.5
LISN coupling specification	Rectangular	± 1.5	± 1.5
Cable and Input Transient Limiter calibration	Normal (k=2)	± 0.3	± 0.5
Mismatch: Receiver VRC $\Gamma_1 = 0.03$ LISN VRC $\Gamma_R = 0.8(9 \text{ kHz}) 0.2 (30 \text{ MHz})$ Uncertainty limits $20\text{Log}(1 \pm \Gamma_1 \Gamma_R)$	U-Shaped	± 0.2	± 0.3
System repeatability	Std. deviation	± 0.2	± 0.05
Repeatability of EUT	--	--	--
Combined standard uncertainty	Normal	± 1.25	± 1.30
Expanded uncertainty U	Normal (k=2)	± 2.50	± 2.60

Sample Calculation for Measurement Accuracy in 450 kHz to 30 MHz Band:

$$u_c(y) = \sqrt{\sum_{i=1}^m u_i^2(y)} = \pm \sqrt{(1.5^2 + 1.5^2)/3 + (0.5/2)^2 + (0.05/2)^2 + 0.35^2} = \pm 1.30 \text{ dB}$$

$$U = 2u_c(y) = \pm 2.6 \text{ dB}$$

7.2. RADIATED EMISSION MEASUREMENT UNCERTAINTY

CONTRIBUTION (Radiated Emissions)	PROBABILITY DISTRIBUTION	UNCERTAINTY (\pm dB)	
		3 m	10 m
Antenna Factor Calibration	Normal (k=2)	± 1.0	± 1.0
Cable Loss Calibration	Normal (k=2)	± 0.3	± 0.5
EMI Receiver specification	Rectangular	± 1.5	± 1.5
Antenna Directivity	Rectangular	± 0.5	± 0.5
Antenna factor variation with height	Rectangular	± 2.0	± 0.5
Antenna phase center variation	Rectangular	0.0	± 0.2
Antenna factor frequency interpolation	Rectangular	± 0.25	± 0.25
Measurement distance variation	Rectangular	± 0.6	± 0.4
Site imperfections	Rectangular	± 2.0	± 2.0
Mismatch: Receiver VRC $\Gamma_1 = 0.2$ Antenna VRC $\Gamma_R = 0.67(Bi) 0.3 (Lp)$ Uncertainty limits $20\text{Log}(1 \pm \Gamma_1 \Gamma_R)$	U-Shaped	+1.1 -1.25	± 0.5
System repeatability	Std. Deviation	± 0.5	± 0.5
Repeatability of EUT		-	-
Combined standard uncertainty	Normal	+2.19 / -2.21	+1.74 / -1.72
Expanded uncertainty U	Normal (k=2)	+4.38 / -4.42	+3.48 / -3.44

Calculation for maximum uncertainty when 3m biconical antenna including a factor of k=2 is used:

$$U = 2u_c(y) = 2x(+2.19) = +4.38 \text{ dB} \quad \text{And} \quad U = 2u_c(y) = 2x(-2.21) = -4.42 \text{ dB}$$

EXHIBIT 8. MEASUREMENT METHODS

8.1. GENERAL TEST CONDITIONS

The following test conditions shall be applied throughout the tests covered in this report.

8.1.1. Normal temperature and humidity

- Normal temperature: +15°C to +35°C
- Relative Humidity: +20% to 75%

The actual values during tests shall be recorded in the test report.

8.1.2. Normal power source

8.1.2.1. Mains Voltage

The nominal test voltage of the equipment to be connected to mains shall be the nominal mains voltage which is the declared voltage or any of the declared voltages for which the equipment was designed.

The frequency of test power source corresponding to the AC mains shall be between 59 Hz and 61 Hz.

8.1.2.2. Battery Power Source.

For operation from battery power sources, the nominal test voltage shall be as declared by the equipment manufacturer. This shall be recorded in the test report.

8.1.3. Operating Condition of Equipment under Test

- All tests were carried out while the equipment operated at the following frequencies:
 - The lowest operating frequency,
 - The middle operating frequency and
 - The highest operating frequency
- Modulation were applied using the Test Data sequence
- The transmitter was operated at the highest output power, or in the case the equipment able to operate at more than one power level, at the lowest and highest output powers

8.2. METHOD OF MEASUREMENTS - AC MAINS CONDUCTED EMISSIONS

- AC Mains conducted emissions measurements were performed in accordance with the standard against appropriate limits for each detector function.
- The test was performed in the shielded room, 16'(L) by 16'(W) by 12'(H).
- The test was performed were made over the frequency range from 450 kHz to 30 MHz to determine the line-to-ground radio noise voltage which was conducted from the EUT power-input terminals that were directly connected to a public power network.
- The EUT normally received power from another device that connects to the public utility ac power lines, measurements would be made on that device with the EUT in operation to ensure that the device continues to comply with the appropriate limits while providing the EUT with power.
- If the EUT operates only from internal or dedicated batteries, with no provisions for connection to the public utility ac power lines, AC Mains conducted measurements are not required.
- Table-top devices were placed on a platform of nominal size 1 m by 1.5m raised 80 cm above the conducting ground plane.
- The EUT current-carrying power lead, except the ground (safety) lead, was individually connected through a LISN to the power source. All unused 50-Ohm connectors of the LISN was terminated in 50-ohm when not connected to the measuring instruments.
- The line cord of the EUT connected to one LISN which was connected to the measuring instrument. Those power cords for the units of devices not under measurement were connected to a separate multiple ac outlet. Drawings and photographs of typically conducted emission test setups were shown in the Test Report. Each current-carrying conductor of the EUT shall be individually tested.
- The EUT was normally operated with a ground (safety) connection, the EUT was connected to the ground at the LISN through a conductor provided in the lead from the ac power mains to the LISN.
- The excess length of the power cord was folded back and forth in an 8-shape on a wooden strip with a vertical prong located on the top of the LISN case.
- The EUT was set-up in its typical configuration and operated in its various modes as described in 3.2 of the test report.
- A preliminary scan was made by using spectrum analyzer system with the detector function set to PEAK mode (9 KHz RBW, VBW > RBW), frequency span 450 kHz to 30 MHz.
- The maximum conducted emission for a given mode of operation was found by using the following step-by-step procedure:
 - Step1. Monitor the frequency range of interest at a fixed EUT azimuth.
 - Step2. Manipulate the system cables and peripheral devices to produce highest amplitude signal relative to the limit. Note the amplitude and frequency of the suspect signal.
 - Step3. The effects of various modes of operation is examined. This is done by varying equipment operation modes as step 2 is being performed.
 - Step4. After completing step 1 through 3, record EUT and peripheral device configuration, mode of operation, cable configuration, signal levels and frequencies for final test.
- Each highest signal level at the maximized test configuration was zoomed in a small frequency span on the spectrum analyzer's display (the manipulation of cables and peripheral devices and EUT operation modes might have to be repeated to obtain the highest signal level with the spectrum analyzer set to PEAK detector mode 10 KHz RBW and VBW > RBW). The spectrum analyzer was then set to CISPR QUASI-PEAK detector mode (9 KHz RBW, 1 MHz VBW) and AVERAGE detector mode (10 kHz RBW, 1 Hz VBW). The final highest RF signal levels and frequencies were record.
- **Broad-band ac Powerline conducted emissions:-** If the EUT exhibits ac Powerline conducted emissions that exceed the limit with the instrument set to the quasi-peak mode, then measurements should be made in the average mode. If

the amplitude measured in the quasi-peak mode is at least 6 dB higher than the amplitude measured in the average mode, the level measured in quasi peak mode may be reduced by 13 dB before comparing it to the limit.

8.3. PEAK CONDUCTED POWER & PEAK EIRP

8.3.1. Measurements of Transmitter Parameters (Duty Cycle & Peak Power)

- The following shall be applied to the combination(s) of the radio device and its intended antenna(e).
- If the RF level is user adjustable, all measurements shall be made with the highest power level available to the user for that combination.
- The following method of measurement shall apply to both conducted and radiated measurements.
- The radiated measurements are performed at the Ultratech Calibrated Open Field Test Site.
- The measurement shall be performed using normal operation of the equipment with modulation.

Test procedure shall be as follows:

Step 1: Duty Cycle (x) and Peak Power (y) parameters measurements

- Connect the transmitter output to a diode detector through an attenuator
- Connect the diode detector to the vertical channel of an oscilloscope.
- The observed duty cycle of the transmitter, $x = \text{Tx on} / (\text{Tx on} + \text{Tx off})$ with $0 < x < 1$, is measure and recorded in the test report. For the purpose of testing, the equipment shall be operated with a duty cycle that is equal or more than 0.1.
- Observe and record the y parameter of the DC level on the oscilloscope.

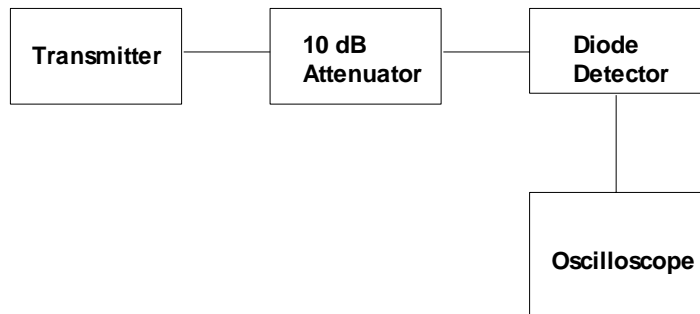

Step 2: Peak Power Measurements

- Replace the transmitter by a RF signal generator
- Set the signal generator frequency be the same as the transmitter frequency
- Adjust the rf output level of the RF signal generator until the DC level on the oscilloscope is same as that (y) recorded in step 1.
- Measure the RF signal generator output level using a power meter
- Calculate the total peak power (P_p) by adding the signal generator level with the attenuator value and the cable loss.

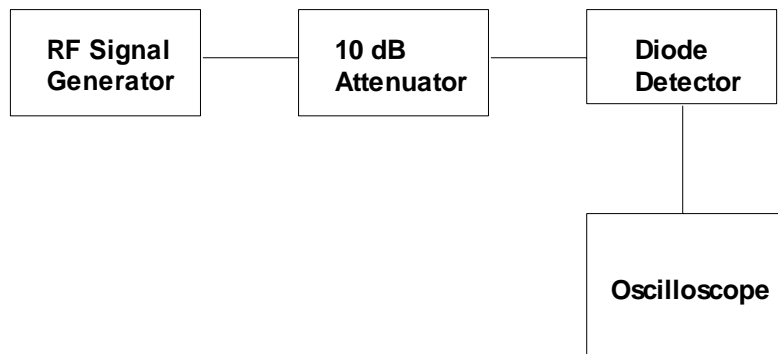

Step 3: Total Peak EIRP Substitution Method. See Figure 2

- (a) The setting of the spectrum analyzer shall be:

Center Frequency:	equal to the signal source
Resolution BW:	100 kHz for FSS, 1 MHz for DIGITAL MODULATION
Video BW:	same
Detector Mode:	positive
Average:	off
Span:	3 x the signal bandwidth

- (b) Connect the transmitter output to the spectrum analyzer and measure the peak power in 1 MHz bandwidth for reference.
- (c) Calculate the difference (K_p) between the total peak power and 1 MHz BW peak power. This value will be used to add onto the 1MHz BW peak EIRP to obtain the TOTAL peak EIRP.
- (d) Test was performed at listed 3m open area test site (listed with FCC, IC, ITI, NVLAP, ACA & VCCI).
- (e) The transmitter under test was placed at the specified height on a non-conducting turntable (80 cm height)
- (f) The horn test antenna was used and tuned to the transmitter carrier frequency.
- (g) The spectrum analyzer was tuned to transmitter carrier frequency. The test antenna was lowered or raised from 1 to 4 meters until the maximum signal level was detected.
- (h) The transmitter was rotated through 360° about a vertical axis until a higher maximum signal was received.
- (i) The test antenna was lowered or raised again from 1 to 4 meters until a maximum was obtained. This level was recorded.
- (j) The substitution horn antenna and the signal generator replaced the transmitter and antenna under test in the same position, and the substitution horn antenna was placed in vertical polarization. The test horn antenna was lowered or raised as necessary to ensure that the maximum signal is still received.
- (k) The input signal to the substitution antenna was adjusted in level until an equal or a known related level to that detected from the transmitter was obtained in the test receiver. The maximum carrier radiated power is equal to the power supply by the generator.

- (l) The substitution antenna gain and cable loss were added to the signal generator level for the corrected 1MHz BW peak EIRP level. The total peak EIRP can be calculated by adding its value with the Kp
- (m) Repeat steps (c) to (j) with the substitution antenna oriented in horizontal polarization. Measured in step (c).
- (n) Actual gain of the EUT's antenna is the difference of the measured ERP and measured RF power at the RF port. Correct the antenna gain if necessary.

Figure 2

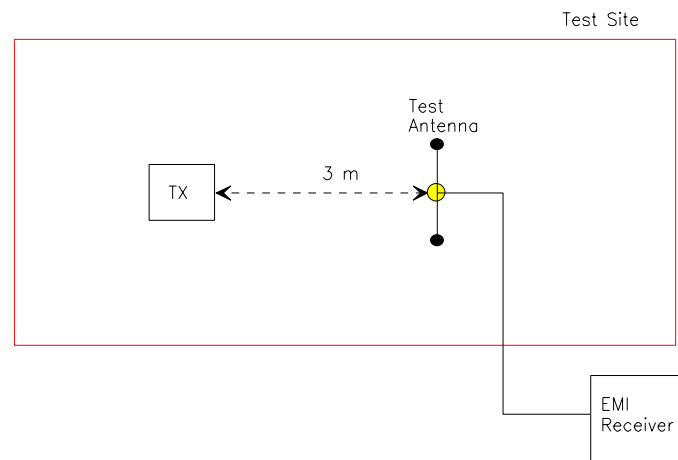
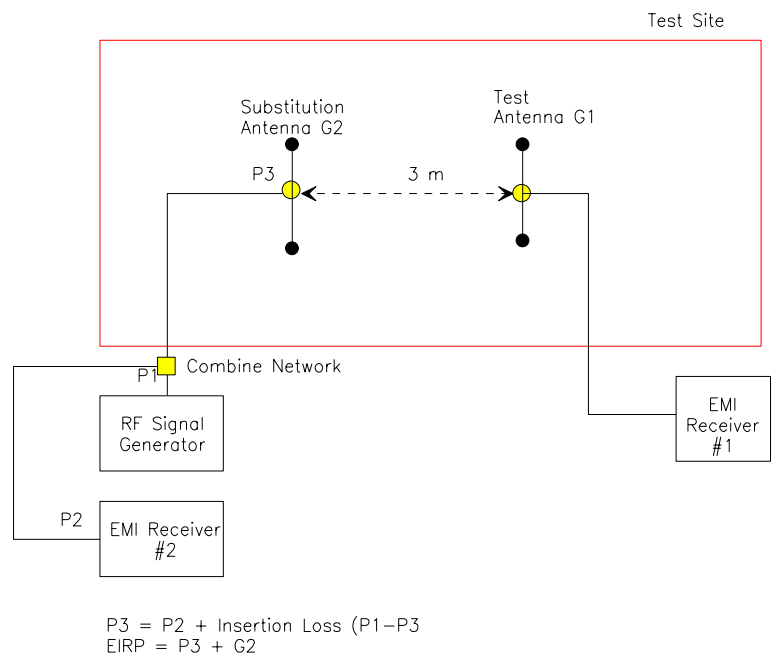

Figure 3



• All test results contained in this engineering test report are traceable to National Institute of Standards and Technology (NIST)

8.4. SPURIOUS EMISSIONS (CONDUCTED & RADIATED)

For both conducted and radiated measurements, the spurious emissions were scanned from the lowest frequency generated by the EUT or 10 MHz whichever is lower to 10th harmonic of the highest frequency generated by the EUT.

8.4.1. Band-edge and Spurious Emissions (Conducted)

Band-edge Compliance of RF Conducted Emissions:

Use the following spectrum analyzer settings:

- The radio was connected to the measuring equipment via a suitable attenuator.
- Span = wide enough to capture the peak level of the emission operating on the channel closest to the band-edge, as well as any modulation products which fall outside of the authorized band of operation.
- RBW = 1 % of the span
- VBW = RBW
- Sweep = auto
- Detector function = peak
- Trace = max hold
- Allow the trace to stabilize
- Set the marker on the emission at the band-edge, or on the highest modulation product outside of the band, if this level is greater than that at the band-edge
- Enable the marker-delta function, then use the marker-to-peak function to move the marker to the peak of the in-band emission.
- The marker-delta value now displayed must comply with the limit specified
- Submit this plot

Spurious RF Conducted Emissions:

Use the following spectrum analyzer settings:

- The radio was connected to the measuring equipment via a suitable attenuator.
- Span = wide enough to capture the peak level of the in-band-emission and all spurious emissions (e.g. harmonics) from the lowest frequency generated in the EUT up through the 10th harmonic. Typically, several plots are required to cover this entire span.
- RBW = 100 kHz
- VBW = RBW
- Sweep = auto
- Detector function = peak
- Trace = max hold
- Allow the trace to stabilize
- Set the marker on the any spurious emission recorded. The level displayed must comply with the limit specified in this Section.
- Submit this plot

8.4.2. Spurious Emissions (Radiated)

- The radiated emission measurements were performed at the UltraTech's 3 Meter Open Field Test Site (OFTS) situated in the Town of Oakville, province of Ontario. The Attenuation Characteristics of OFTS have been filed to FCC, Industry Canada, ACA/Austel, NVLap and ITI.
- Radiated emissions measurements were made using the following test instruments:
 1. Calibrated EMCO BiconiLog antenna in the frequency range from 30 MHz to 2000 MHz.
 2. Calibrated Emco Horn antennas in the frequency range above 1000 MHz (1GHz - 40 GHz).

ULTRATECH GROUP OF LABS

3000 Bristol Circle, Oakville, Ontario, Canada L6H 6G4
Tel. #: 905-829-1570, Fax. #: 905-829-8050, Email: vic@ultratech-labs.com, Website: <http://www.ultratech-labs.com>

File #: TEK-434FCC15C
Jan. 19, 2004

- All test results contained in this engineering test report are traceable to National Institute of Standards and Technology (NIST)

3. The test is required for any spurious emission or modulation product that falls in a Restricted Band, as defined in Section 15.205. It must be performed with the highest gain of each type of antenna proposed for use with the EUT. Use the following spectrum analyzer settings:
- RBW = 100 kHz for $f < 1\text{GHz}$ and RBW = 1 MHz for $f \geq 1\text{GHz}$
 - VBW = RBW
 - Sweep = auto
 - Detector function = peak
 - Trace = max hold
 - Follows the guidelines in ANSI C63.4-1992 with respect to maximizing the emission by rotating the EUT, measuring the emission while the EUT is situated in three orthogonal planes (if appropriate), adjusting the measurement antenna height and polarization, etc.. A pre-amp and highpass filter are required for this test, in order to provide the measuring system with sufficient sensitivity.
 - Allow the trace to stabilize.
 - The peak reading of the emission, after being corrected by the antenna correction factor, cable loss, pre-amp gain, etc.... is the peak field strength which comply with the limit specified in Section 15.35(b)

Calculation of Field Strength:

The field strength is calculated by adding the calibrated antenna factor and cable factor, and subtracting the Amplifier gain (if any) from the measured reading. The basic equation with a sample calculation is as follows:

$$FS = RA + AF + CF - AG$$

Where	FS	=	Field Strength
	RA	=	Receiver/Analyzer Reading
	AF	=	Antenna Factor
	CF	=	Cable Attenuation Factor
	AG	=	Amplifier Gain

Example: If a receiver reading of 60.0 dBuV is obtained, the antenna factor of 7.0 dB/m and cable factor of 1.0 dB are added, and the amplifier gain of 30 dB is subtracted. The actual field strength will be:

$$\text{Field Level} = 60 + 7.0 + 1.0 - 30 = 38.0 \text{ dBuV/m.}$$

$$\text{Field Level} = 10^{(38/20)} = 79.43 \text{ uV/m.}$$

- Submit this test data
- Now set the VBW to 10Hz, while maintaining all of the other instrument settings. This peak level, once corrected, must comply with the limit specified in Section 15.209. If the dwell time of the each channel is less than 100ms, then the reading obtained may be further adjusted by a “duty cycle correction factor”, derived from $10\log(\text{dwell time}/100\text{mS})$ in an effort to demonstrate compliance with the 15.209.
- Submit test data

Maximizing The Radiated Emissions:

- The frequencies of emissions was first detected. Then the amplitude of the emissions was measured at the specified measurement distance using required antenna height, polarization, and detector characteristics.
- During this process, cables and peripheral devices were manipulated within the range of likely configuration.
- For each mode of operation required to be tested, the frequency spectrum was monitored. Variations in antenna heights (from 1 meter to 4 meters above the ground plane), antenna polarization (horizontal plane and vertical

ULTRATECH GROUP OF LABS

3000 Bristol Circle, Oakville, Ontario, Canada L6H 6G4
Tel. #: 905-829-1570, Fax. #: 905-829-8050, Email: vic@ultratech-labs.com, Website: <http://www.ultratech-labs.com>

File #: TEK-434FCC15C

Jan. 19, 2004

- All test results contained in this engineering test report are traceable to National Institute of Standards and Technology (NIST)

plane), cable placement and peripheral placement were explored to produce the highest amplitude signal relative to the limit.

The maximum radiated emission for a given mode of operation was found by using the following step-by-step procedure:

- Step1: Monitor the frequency range of interest at a fixed antenna height and EUT azimuth.
- Step2: Manipulate the system cables to produce highest amplitude signal relative to the limit. Note the amplitude and frequency of the suspect signal.
- Step3: Rotate the EUT 360 degrees to maximize the suspected highest amplitude signal. If the signal or another at a different frequency is observed to exceed the previously noted highest amplitude signal by 1 dB or more, go back to the azimuth and repeat Step 2. Otherwise, orient the EUT azimuth to repeat the highest amplitude observation and proceed.
- Step4: Move the antenna over its full allowable range of travel (1 to 4 meters) to maximize the suspected highest amplitude signal. If the signal or another at a different frequency is observed to exceed the previously noted highest amplitude signal by 1 dB or more, return to Step 2 with the highest amplitude observation and proceed.
- Step5: Change the polarization of the antenna and repeat Step 2 through 4. Compare the resulting suspected highest amplitude signal with that found for the other polarization. Select and note the higher of the two signals. This signal is termed the highest observed signal with respect to the limit for this EUT operational mode.
- Step6: The effects of various modes of operation is examined. This is done by varying the equipment modes as steps 2 through 5 are being performed.
- Step7: After completing steps 1 through 6, record the final highest emission level, frequency, antenna polarization and detector mode of the measuring instrument.

8.5. ALTERNATIVE TEST PROCEDURES

If the antenna conducted tests cannot be performed on this device, radiated tests show compliance with the peak output power limit specified in Section 15.247(b) and the spurious RF conducted emission limit specified in Section 15.247(c) are acceptable. As stated previously, a pre-amp, and, in the later case, a high pass filter, are required for the following measurements:

8.5.1. Peak Power Measurements

Calculate the transmitter's peak power using the following equation:

$$E = 30PG/d$$
$$P = (Ed)^2/30G$$

Where:

- E: measured maximum fundamental field strength in V/m. Utilizing a RBW, the 20 dB bandwidth of the emission VBW >RBW, peak detector function. Follow the procedures in C63.4-1992 with respect to maximizing the emission
- G is numeric gain of the transmitting antenna with reference to an isotropic radiator
- D is the distance in meters from which the field strength was measured

- P is the distance in meters from which the field strength was measured

8.5.2. Spurious RF conducted emissions

The demonstrate compliance with the spurious RF conducted emission requirement of Section 15.247©, use the following spectrum analyzer settings:

- Span = wide enough to fully capture the emission being measured
- RBW = 100 kHz
- Sweep = auto
- Detector function = peak
- Trace = max hold
- Measure the field strength of both the fundamental and all spurious emissions with these settings.
- Follow the procedures C62-4:1994 with respect to maximizing the emissions. The measured field strength of all spurious emissions must be below the measured field strength of the fundamental emission by the amount specified in Section 15.247©. Note that if the emission falls in a Restricted Band, as defined in Section 15.205, the procedure for measuring spurious radiated emissions listed above must be followed

8.6. TRANSMITTED POWER DENSITY OF A DIGITAL MODULATION SYSTEM

- The radio was connected to the measuring equipment via a suitable attenuator.
- Locate and zoom in on emission peak(s) within the passband
- The spectrum analyzer were used and set as follows:
 - Resolution BW: 3 kHz
 - Video BW: same or greater
 - Detector Mode: Normal
 - Averaging: Off
 - Span: 3 MHz
 - Amplitude: Adjust for middle of the instrument's range
 - Sweep Time: 1000 seconds
- Locate and zoom in on emission peak(s) within the passband. Set RBW = 3 KHz, VBW \geq RBW, Sweep = SPAN/3 KHz. For example, a span of 1.5 MHz, the sweep should be $1.6 \times 10^6 / 3.0 \times 10^3 = 500$ seconds. The measured peak level must be no greater than +8 dBm.
- For devices with spectrum line spacing greater than 3 KHz no change is required.
- For devices with spectrum line spacing equal to or less than 3 KHz, the resolution bandwidth must be reduced below 3 KHz until the individual lines in the spectrum are resolved. The measurement data must then be normalized to 3 KHz by summing the power of all the individual spectral lines within 3 KHz band (in linear power units) to determine compliance.
- If the spectrum line spacing cannot be resolved on the available spectrum analyzer, the noise density function on most modern conventional spectrum analyzer will directly measure the noise power density normalized to 1 Hz noise power bandwidth. Add 30 dB for correction to 3 KHz.
- Should all the above fail or any controversy develop regarding accuracy of measurement, the Laboratory will use HP 89440A Vector Signal Analyzer for final measurement unless a clear showing can be made for a further alternate.