

VERIFICATION CERTIFICATE

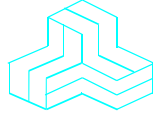

NOT TRANSFERABLE

This Verification Certificate is hereby issued to the named GRANTEE and is VALID ONLY for the equipment identified hereon for use under the rules and regulations listed below:

GRANTEE:

Psion Teklogix, Inc.

Address:

2100 Meadowvale Blvd.
Mississauga, Ontario
Canada, L5N 7J9

Contact Person:

Mr. Sada Dharwarkar
Phone #: 905-812-6200 (3358)
Fax #: 905-812-6301
Email Address: Sada.Dharwarkar@psionteklogix.com

Equipment Type:

Unintentional Radiators

Product Name:

Handheld Computer

Model No.:

7535 G2

Year of manufacture:

2006

**The above product was tested by
UltraTech Engineering Labs Inc.
and found to comply with:**

FCC Part 15, Subpart B - Class B Unintentional Radiators

- **Note(s):** See attached report, UltraTech's File No.: TEK-529F15B, dated February 27, 2006 for details and conditions of Verification Compliance.



Approved by: Tri M. Luu, P.Eng.
V.P. – Engineering

UltraTech

3000 Bristol Circle, Oakville, Ontario, Canada, L6H 6G4

Tel.: (905) 829-1570 Fax.: (905) 829-8050

Website: www.ultratech-labs.com, Email: vic@ultratech-labs.com, Email: tri@ultratech-labs.com



31040/SIT



C-1376



46390-2049



200093-0



SL2-IN-E-1119R



00-034



ENGINEERING TEST REPORT

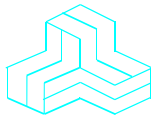

Handheld Computer Model No.: 7535 G2

Applicant:

Psion Teklogix Inc.
2100 Meadowvale Blvd.
Mississauga, ON
Canada, L5N 7J9

Tested in Accordance With

**Federal Communications Commission (FCC)
CFR 47, Part 15, Subpart B
Class B Unintentional Radiators**

UltraTech's File No.: TEK-529F15B

This Test report is Issued under the Authority of
Tri M. Luu, Professional Engineer,
Vice President of Engineering
UltraTech Group of Labs



Date: February 27, 2006

Report Prepared by: Dan Huynh

Tested by: Mr. Hung Trinh, EMI/RFI Technician

Issued Date: February 27, 2006

Test Dates: January 26 - February 24, 2006

- *The results in this Test Report apply only to the sample(s) tested, and the sample tested is randomly selected.*
- *This report must not be used by the client to claim product endorsement by NVLAP or any agency of the US Government.*

UltraTech

3000 Bristol Circle, Oakville, Ontario, Canada, L6H 6G4
Tel.: (905) 829-1570 Fax.: (905) 829-8050
Website: www.ultratech-labs.com, Email: vic@ultratech-labs.com, Email: tri@ultratech-labs.com



TABLE OF CONTENTS

EXHIBIT 1.	INTRODUCTION.....	1
1.1.	SCOPE	1
1.2.	RELATED SUBMITTAL(S)/GRANT(S)	1
1.3.	NORMATIVE REFERENCES	1
EXHIBIT 2.	PERFORMANCE ASSESSMENT.....	2
2.1.	CLIENT INFORMATION	2
2.2.	EQUIPMENT UNDER TEST (EUT) INFORMATION	2
2.3.	LIST OF EUT'S PORTS.....	3
2.4.	ANCILLARY EQUIPMENT	3
EXHIBIT 3.	EUT OPERATING CONDITIONS AND CONFIGURATIONS DURING TESTS.....	4
3.1.	CLIMATE TEST CONDITIONS.....	4
3.2.	OPERATIONAL TEST CONDITIONS & ARRANGEMENT FOR TESTS.....	4
3.3.	TEST SETUP BLOCK DIAGRAM	4
3.4.	PHOTOGRAPHS OF TEST SETUP FOR AC CONDUCTED EMISSION MEASUREMENTS	5
3.5.	PHOTOGRAPHS OF TEST SETUP FOR RADIATED EMISSION MEASUREMENTS	7
EXHIBIT 4.	SUMMARY OF TEST RESULTS	9
4.1.	LOCATION OF TESTS	9
4.2.	APPLICABILITY & SUMMARY OF EMC EMISSION TEST RESULTS	9
4.3.	MODIFICATIONS REQUIRED FOR COMPLIANCE.....	9
4.4.	DEVIATION OF THE STANDARD TEST PROCEDURES	9
EXHIBIT 5.	MEASUREMENTS, EXAMINATIONS & TEST DATA FOR EMC EMISSIONS.....	10
5.1.	TEST PROCEDURES.....	10
5.2.	MEASUREMENT UNCERTAINTIES	10
5.3.	MEASUREMENT EQUIPMENT USED	10
5.4.	AC POWER LINE CONDUCTED EMISSIONS [47 CFR § 15.107(a)]	11
5.5.	RADIATED EMISSIONS FROM CLASS B UNINTENTIONAL RADIATORS (DIGITAL DEVICES) [47 CFR § 15.109(a)]	14
EXHIBIT 6.	MEASUREMENT UNCERTAINTY	16
6.1.	LINE CONDUCTED EMISSION MEASUREMENT UNCERTAINTY	16
6.2.	RADIATED EMISSION MEASUREMENT UNCERTAINTY	17
EXHIBIT 7.	LABELLING & VERIFICATION REQUIREMENTS	18
7.1.	SECTION 15.19 – LABELLING REQUIREMENTS	18
7.2.	SECTIONS 15.21 & 15.105 – INFORMATION TO USER.....	18
7.3.	SECTION 2.906 - VERIFICATION.....	19
7.4.	SECTION 2.909 – RESPONSIBLE PARTY	19
7.5.	SECTION 2.945 – SAMPLING TEST OF EQUIPMENT COMPLIANCE.....	19
7.6.	SECTION 2.946 – PENALTY FOR FAILURE TO PROVIDE TEST SAMPLES AND DATA	19
7.7.	SECTION 2.952 - LIMITATION ON VERIFICATION	20
7.8.	SECTION 2.953 - RESPONSIBILITY OF MANUFACTURER OR IMPORTER	20
7.9.	SECTION 2.954 - IDENTIFICATION	20
7.10.	SECTION 2.955 - RETENTION OF RECORDS	21
7.11.	SECTION 2.956 - FCC INSPECTION & SUBMISSION OF EQUIPMENT FOR TESTING	21
7.12.	SECTION 2.957 - SAMPLING TESTS OF EQUIPMENT COMPLIANCE.....	21

EXHIBIT 1. INTRODUCTION

1.1. SCOPE

Reference:	FCC Part 15, Subpart B, Sections 15.107 & 15.109
Title:	Code of Federal Regulations (CFR), Title 47 - Telecommunication, Part 15
Purpose of Test:	FCC Verification Authorization for a Class B Unintentional Radiators.
Test Procedures:	Both conducted and radiated emissions measurements were conducted in accordance with American National Standards Institute ANSI C63.4 - American National Standard for Methods of Measurement of Radio-Noise Emissions from Low-Voltage Electrical and Electronic Equipment in the Range of 9 kHz to 40 GHz.
Environmental Classification:	Residential, Light-industry, Commercial & Industry

1.2. RELATED SUBMITTAL(S)/GRANT(S)

None.

1.3. NORMATIVE REFERENCES

Publication	Year	Title
CISPR 22 CISPR 22 +A1 EN 55022	2003-04-10 2004-10-14 2003	Information Technology Equipment - Radio Disturbance Characteristics – Limits and Methods of Measurement
ANSI C63.4	2003	American National Standard for Methods of Measurement of Radio-Noise Emissions from Low-Voltage Electrical and Electronic Equipment in the Range of 9 KHz to 40 GHz
CISPR 16-1-1	2003	Specification for radio disturbance and immunity measuring apparatus and methods. Part 1-1: Measuring Apparatus
CISPR 16-2-1	2004	Specification for radio disturbance and immunity measuring apparatus and methods. Part 2-1: Conducted disturbance measurement
FCC CFR 47 Parts 0-15	2005	Code of Federal Regulations, Title 47 - Telecommunication

EXHIBIT 2. PERFORMANCE ASSESSMENT

2.1. CLIENT INFORMATION

APPLICANT	
Name:	Psion Teklogix Inc.
Address:	2100 Meadowvale Blvd. Mississauga, ON Canada, L5N 7J9
Contact Person:	Mr. Sada Dharwarkar Phone #: 905-812-6200 (3358) Fax #: 905-812-6301 Email Address: Sada.Dharwarkar@psionteklogix.com

MANUFACTURER	
Name:	Psion Teklogix Inc.
Address:	2100 Meadowvale Blvd. Mississauga, ON Canada, L5N 7J9
Contact Person:	Mr. Sada Dharwarkar Phone #: 905-812-6200 (3358) Fax #: 905-812-6301 Email Address: Sada.Dharwarkar@psionteklogix.com

2.2. EQUIPMENT UNDER TEST (EUT) INFORMATION

The following information (with the exception of the Date of Receipt) has been supplied by the applicant.

Brand Name:	Psion Teklogix Inc.
Product Name:	Handheld Computer
Model Name or Number:	7535 G2
Serial Number:	Test sample
Type of Equipment:	Unintentional Radiators
External Power Supply:	Sino-American AC/DC adapter, model SA150A-1533U-3 RoHS
Oscillators' Frequency(ies):	32.768 kHz, 6.0 MHz, 13 MHz, 3.6864 MHz, 7.3728 MHz, 48 MHz, 24.576 MHz
Power input source:	The 7535 G2 is powered by a lithium-ion rechargeable battery pack. The 7535 G2 can be powered from external power when used with the AC adapter. When the 7535 G2 is powered from the AC adaptor, it will also charge the battery pack.

2.3. LIST OF EUT'S PORTS

Port Number	EUT's Port Description	Number of Identical Ports	Connector Type	Cable Type (Shielded/Non-shielded)
1	Tether	1	Mini-DIN 8 Pin	Decoded Scanner
2	Docking	1	N/A	Terminated with Portable Docking Module

2.4. ANCILLARY EQUIPMENT

The EUT was tested while connected to the following representative configuration of ancillary equipment necessary to exercise the ports during tests:

Ancillary Equipment # 1	
Description:	Scanner Symbol
Brand name:	Psion Teklogix
Serial Number:	M1J3 7E70W
Connected to EUT's Port:	Mini-DIN 8 Pin

EXHIBIT 3. EUT OPERATING CONDITIONS AND CONFIGURATIONS DURING TESTS

3.1. CLIMATE TEST CONDITIONS

The climate conditions of the test environment are as follows:

Temperature:	21°C
Humidity:	51%
Pressure:	102 kPa
Power input source:	15 V DC from power adaptor

3.2. OPERATIONAL TEST CONDITIONS & ARRANGEMENT FOR TESTS

The EUT was set in emc approvals program. Program is design to trigger internal scanner every 12s and to continuously scroll known data (text) on the display. External scanner was connected to the tether port in standby mode.

3.3. TEST SETUP BLOCK DIAGRAM

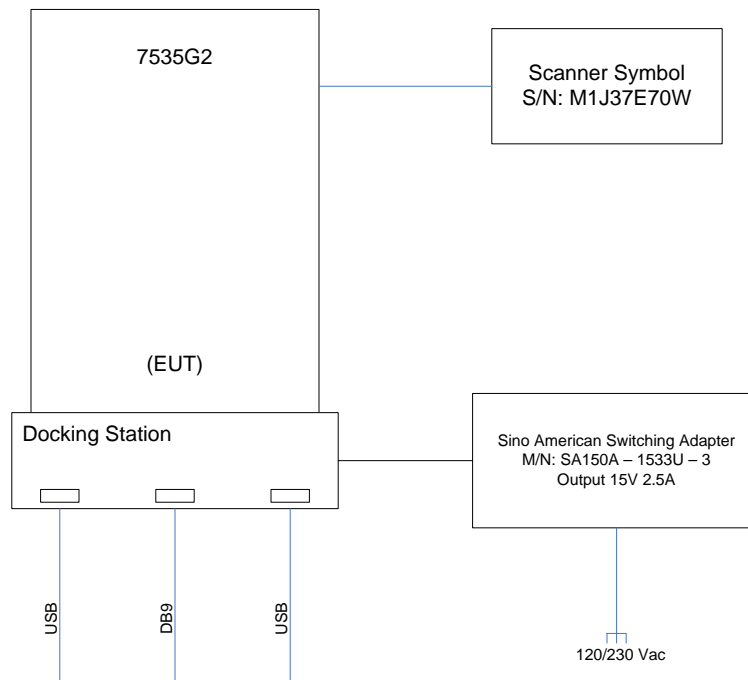

3.4. PHOTOGRAPHS OF TEST SETUP FOR AC CONDUCTED EMISSION MEASUREMENTS





3.5. PHOTOGRAPHS OF TEST SETUP FOR RADIATED EMISSION MEASUREMENTS

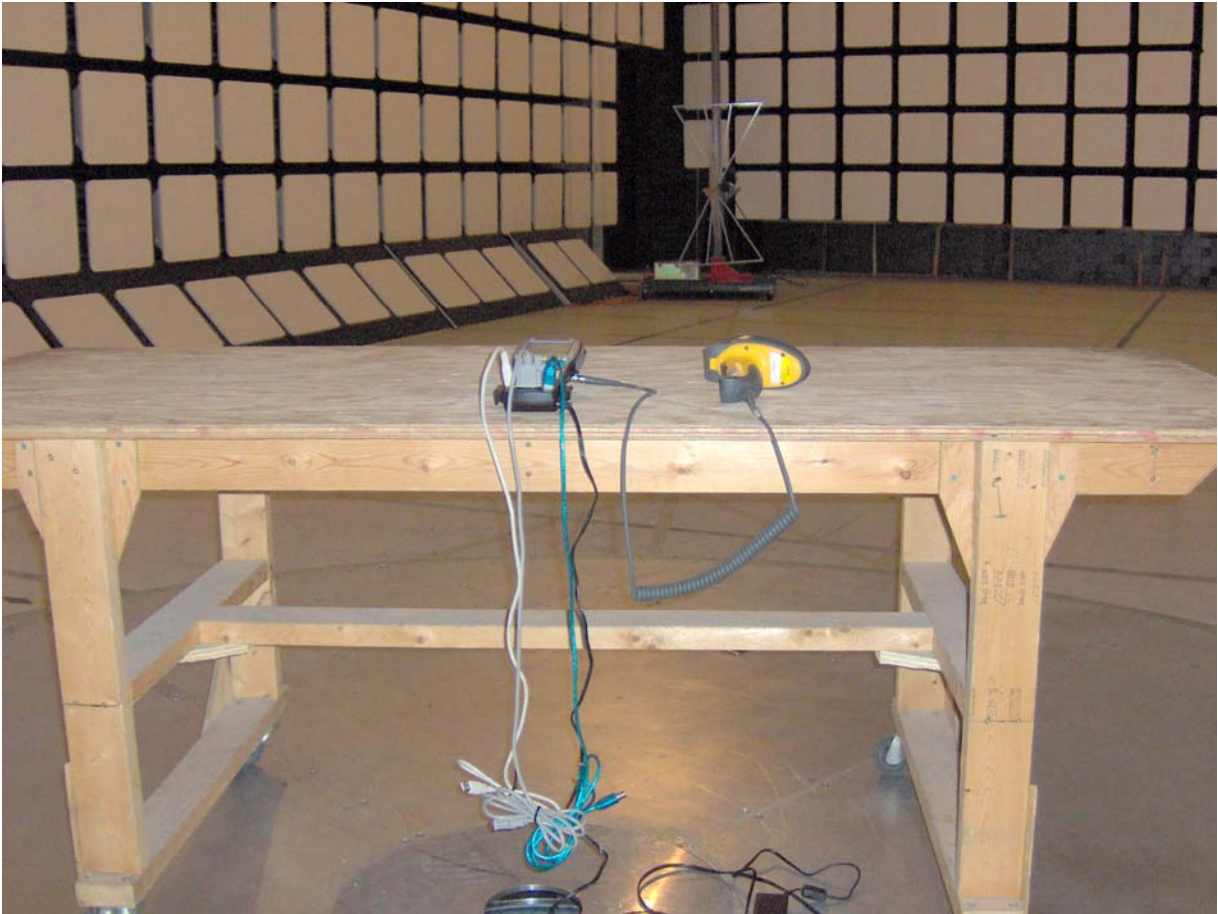



EXHIBIT 4. SUMMARY OF TEST RESULTS

4.1. LOCATION OF TESTS

All of the measurements described in this report were performed at Ultratech Group of Labs located in the city of Oakville, Province of Ontario, Canada.

- AC Power Line Conducted Emissions were performed in UltraTech's shielded room, 24'(L) by 16'(W) by 8'(H).
- Radiated Emissions were performed at the Ultratech's 3-10 TDK Semi-Anechoic Chamber situated in the Town of Oakville, province of Ontario. This test site been calibrated in accordance with ANSI C63.4, and found to be in compliance with the requirements of Sec. 2.948 of the FCC Rules. The descriptions and site measurement data of the Oakville 3-10 TDK Semi-Anechoic Chamber has been filed with FCC office (FCC File No.: 31040/SIT 1300B3) and Industry Canada office (Industry Canada File No.: IC2049-1). Last Date of Site Calibration: June. 20, 2005.

4.2. APPLICABILITY & SUMMARY OF EMC EMISSION TEST RESULTS

FCC Part 15, Subpart B	Test Requirements	Margin Below (-) / Above (+) the Limits	Compliance (Yes/No)
15.107(a), Class B	Power Line Conducted Emissions Measurements	-15.8dB @ 0.19 MHz	Yes
15.109(a), Class B	Radiated Emissions from Unintentional Radiators (Digital Devices)	-1.0 dB @ 400.00 MHz	Yes

4.3. MODIFICATIONS REQUIRED FOR COMPLIANCE

None.

4.4. DEVIATION OF THE STANDARD TEST PROCEDURES

None.

EXHIBIT 5. MEASUREMENTS, EXAMINATIONS & TEST DATA FOR EMC EMISSIONS

5.1. TEST PROCEDURES

Please refer to Ultratech Test Procedures, File# ULTR-P001-2004, ANSI C63.4, CISPR 22 / EN 55022, CISPR 16-1-2 and CISPR 16-2-3 for Test Procedures.

5.2. MEASUREMENT UNCERTAINTIES

The measurement uncertainties stated were calculated in accordance with requirements of UKAS Document LAB 34 with a confidence level of 95%. Please refer to Exhibit 6 for Measurement Uncertainties.

5.3. MEASUREMENT EQUIPMENT USED

The measurement equipment used complied with the requirements of the Standards referenced in the Methods & Procedures ANSI C63.4 and CIPSR 16-1-1.

5.4. AC POWER LINE CONDUCTED EMISSIONS [47 CFR § 15.107(a)]

5.4.1. Limits

The equipment shall meet the limits of the following table:

Frequency of emission (MHz)	Conducted Limits (dBµV)	
	Quasi-peak	Average
0.15–0.5	66 to 56*	56 to 46*
0.5–5	56	46
5-30	60	50

*Decreases with the logarithm of the frequency

5.4.2. Method of Measurements

Refer to Ultratech Test Procedures ULTR-P001-2004 & ANSI C63.4 for method of measurements.

5.4.3. Test Equipment List

Test Instruments	Manufacturer	Model No.	Serial No.	Frequency Range
Spectrum Analyzer/EMI Receiver	Hewlett Packard	HP 8593EM	3412A00103	9 kHz – 26.5 GHz
Transient Limiter	Hewlett Packard	11947A	310701998	9 kHz – 200 MHz 10 dB attenuation
L.I.S.N.	EMCO	3825/2	89071531	9 kHz – 200 MHz 50 Ohms / 50 µH
24'(L) x 16'(W) x 8'(H) RF Shielded Chamber	Braden Shielding

5.4.4. Test Data

Frequency (MHz)	RF Level (dBµV)	Receiver Detector (P/QP/AVG)	QP Limit (dBuV)	AVG Limit (dBuV)	Margin (dB)	Pass/ Fail	Line Tested (L1/L2)
0.186345	48.4	QP	64.2	54.2	-15.8	Pass	L1
0.186345	35.2	AVG	64.2	54.2	-19.0	Pass	L1
15.847750	29.9	QP	60.0	50.0	-30.1	Pass	L1
15.847750	23.4	AVG	60.0	50.0	-26.6	Pass	L1
0.183650	48.2	QP	64.3	54.3	-16.1	Pass	L2
0.183650	29.7	AVG	64.3	54.3	-24.6	Pass	L2

See the following plots for detailed measurements

Plot 5.4.4.1:
Power Line Conducted Emissions
Line Voltage: 120 VAC 60 Hz
Line Tested: 1

hp

Signal	Freq (MHz)	PK Amp	QP Amp	AV Amp	AV Δ L2
1	0.186345	56.3	48.4	35.2	-19.1
2	15.847750	32.2	29.9	23.4	-26.6

ACTV DET: PEAK
MEAS DET: PEAK QP AVG
MKR 15.95 MHz
29.27 dB μ V

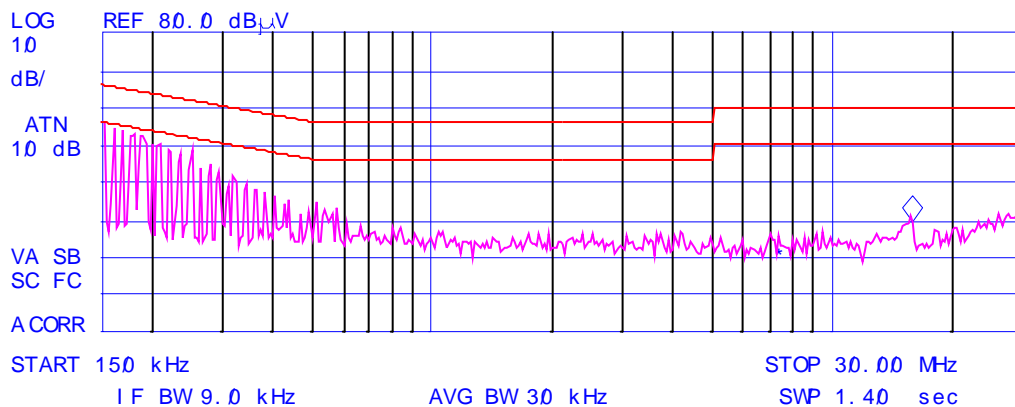

Plot 5.4.4.2:
Power Line Conducted Emissions
Line Voltage: 120 VAC 60 Hz
Line Tested: 2

hp

Signal	Freq (MHz)	PK Amp	QP Amp	AV Amp	AV Δ L2
1	0.183650	55.6	46.2	29.7	-24.6

ACTV DET: PEAK
MEAS DET: PEAK QP AVG
MKR 180 kHz
48.88 dB μ V

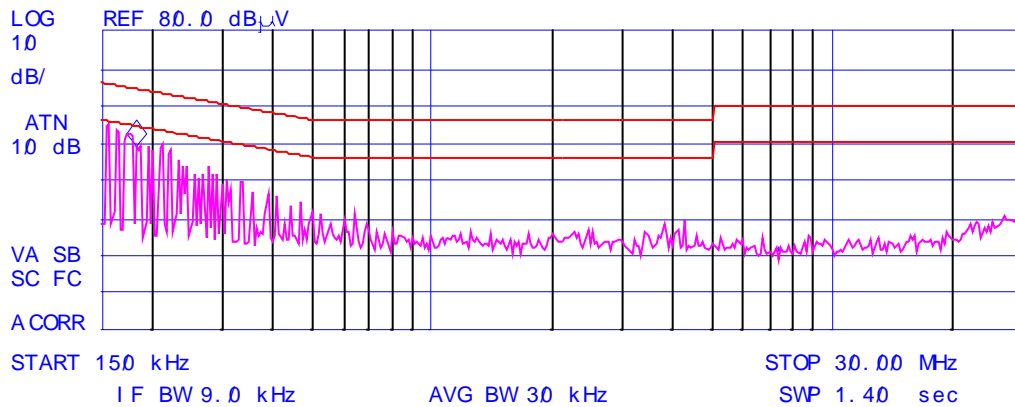

5.5. RADIATED EMISSIONS FROM CLASS B UNINTENTIONAL RADIATORS (DIGITAL DEVICES) [47 CFR § 15.109(a)]

5.5.1. Limits

The equipment shall meet the limits of the following table:

Frequency of emission (MHz)	Class B Limits	
	(dB μ V/m at 3 m)	(dB μ V/m at 10 m)
30 – 88	40.0	29.5
88 – 216	43.5	33.1
216 – 960	46.0	35.6
Above 960	54.0	43.5

5.5.2. Method of Measurements

Refer to Ultratech Test Procedures ULTR-P001-2004 & ANSI C63.4 for method of measurements.

The spectrum shall be investigated from the lowest radio frequency signal generated or used in the device, without going below the lowest frequency for which a radiated emission limit is specified, up to the frequency shown in the following table:

Highest frequency generated or used in the device or on which the device operates or tunes (MHz)	Upper frequency of measurement range (MHz)
Below 1.705	30
1.705 – 108	1000
108 – 500	2000
500 -1000	5000
Above 1000	5 th harmonic of the highest frequency or 40 GHz, whichever is lower

5.5.3. Test Equipment List

Test Instruments	Manufacturer	Model No.	Serial No.	Frequency Range
Spectrum Analyzer/EMI Receiver	Advantest	R3271	15050203	100 Hz to 32 GHz with external mixer for frequency above 32 GHz
EMI Receiver System / Spectrum Analyzer	Hewlett Packard	HP 8546A	3520A00248	9KHz-5.6GHz, 50 Ohms
Microwave Amplifier	Hewlett Packard	HP 83017A	311600661	1 GHz to 26.5 GHz
Biconilog Antenna	EMCO	3143	1029	20 MHz to 2 GHz
Horn Antenna	EMCO	3155	9701-5061	1 GHz – 18 GHz

5.5.4. Test Data

The radiated emissions were scanned from 30 MHz to 5 GHz; all spurious emissions within 20dB below the limits were recorded.

Frequency (MHz)	RF Level (dBµV/m)	Detector Used (Peak/QP)	Antenna Plane (H/V)	Limit at 10 m (dBµV/m)	Margin (dB)
91.30	24.91	Peak	V	33.1	-8.2
91.30	15.98	Peak	H	33.1	-17.1
104.40	22.70	Peak	V	33.1	-10.4
181.40	22.40	Peak	V	33.1	-10.7
181.40	18.90	Peak	H	33.1	-14.2
186.60	21.62	Peak	V	33.1	-11.5
192.80	21.85	Peak	V	33.1	-11.3
198.90	21.64	Peak	V	33.1	-11.5
312.80	26.95	Peak	V	35.6	-8.7
312.80	29.76	Peak	H	35.6	-5.8
320.40	30.05	Peak	V	35.6	-5.6
320.40	31.95	Peak	H	35.6	-3.7
370.70	26.52	Peak	V	35.6	-9.1
370.70	25.88	Peak	H	35.6	-9.7
376.80	26.26	Peak	V	35.6	-9.3
376.80	29.78	Peak	H	35.6	-5.8
395.30	29.64	Peak	V	35.6	-6.0
395.30	30.76	Peak	H	35.6	-4.8
400.00	31.59	QP	V	35.6	-4.0
400.00	34.56	QP	H	35.6	-1.0

EXHIBIT 6. MEASUREMENT UNCERTAINTY

The measurement uncertainties stated were calculated in accordance with the requirements of NIST Technical Note 1297 and LAB 34

6.1. LINE CONDUCTED EMISSION MEASUREMENT UNCERTAINTY

CONTRIBUTION (Line Conducted)	PROBABILITY DISTRIBUTION	UNCERTAINTY (dB)	
		9-150 kHz	0.15-30 MHz
EMI Receiver specification	Rectangular	± 1.5	± 1.5
LISN coupling specification	Rectangular	± 1.5	± 1.5
Cable and Input Transient Limiter calibration	Normal (k=2)	± 0.3	± 0.5
Mismatch: Receiver VRC $\Gamma_1 = 0.03$ LISN VRC $\Gamma_R = 0.8(9 \text{ kHz}) 0.2 (30 \text{ MHz})$ Uncertainty limits $20\text{Log}(1 \pm \Gamma_1 \Gamma_R)$	U-Shaped	± 0.2	± 0.3
System repeatability	Std. deviation	± 0.2	± 0.05
Repeatability of EUT	--	--	--
Combined standard uncertainty	Normal	± 1.25	± 1.30
Expanded uncertainty U	Normal (k=2)	± 2.50	± 2.60

Sample Calculation for Measurement Accuracy in 450 kHz to 30 MHz Band:

$$u_c(y) = \sqrt{\sum_{i=1}^m u_i^2(y)} = \pm \sqrt{(1.5^2 + 1.5^2)/3 + (0.5/2)^2 + (0.05/2)^2 + 0.35^2} = \pm 1.30 \text{ dB}$$

$$U = 2u_c(y) = \pm 2.6 \text{ dB}$$

6.2. RADIATED EMISSION MEASUREMENT UNCERTAINTY

CONTRIBUTION (Radiated Emissions)	PROBABILITY DISTRIBUTION	UNCERTAINTY (+ dB)	
		3 m	10 m
Antenna Factor Calibration	Normal (k=2)	± 1.0	± 1.0
Cable Loss Calibration	Normal (k=2)	± 0.3	± 0.5
EMI Receiver specification	Rectangular	± 1.5	± 1.5
Antenna Directivity	Rectangular	+0.5	+0.5
Antenna factor variation with height	Rectangular	± 2.0	± 0.5
Antenna phase center variation	Rectangular	0.0	± 0.2
Antenna factor frequency interpolation	Rectangular	± 0.25	± 0.25
Measurement distance variation	Rectangular	± 0.6	± 0.4
Site imperfections	Rectangular	± 2.0	± 2.0
Mismatch: Receiver VRC $\Gamma_1 = 0.2$ Antenna VRC $\Gamma_R = 0.67(\text{Bi}) 0.3 (\text{Lp})$ Uncertainty limits $20\text{Log}(1 \pm \Gamma_1 \Gamma_R)$	U-Shaped	+1.1 -1.25	± 0.5
System repeatability	Std. Deviation	± 0.5	± 0.5
Repeatability of EUT		-	-
Combined standard uncertainty	Normal	+2.19 / -2.21	+1.74 / -1.72
Expanded uncertainty U	Normal (k=2)	+4.38 / -4.42	+3.48 / -3.44

Calculation for maximum uncertainty when 3m biconical antenna including a factor of k=2 is used:

$U = 2u_c(y) = 2x(+2.19) = +4.38 \text{ dB}$ And $U = 2u_c(y) = 2x(-2.21) = -4.42 \text{ dB}$

EXHIBIT 7. LABELLING & VERIFICATION REQUIREMENTS

7.1. SECTION 15.19 – LABELLING REQUIREMENTS

For a Class A digital device or peripheral, the instructions furnished the user shall include the following or similar statement, placed in a prominent location in the text of the manual.

This device complies with Part 15 of the FCC Rules. Operation is subject to the following two conditions: (1) this device may not cause harmful interference and (2) this device must accept any interference received, including interference that may cause undesired operation.

- (1) The label shall NOT be a stick-on , paper label. The label on these products shall be permanently affixed to the product and shall be readily visible to the purchaser at the time of purchase, as described in FCC 2.925(d). "Permanently" affixed means that the label is etched, engraved, stamped, silk-screened, indelibly printed, or otherwise permanently marked on a permanently attached part of the equipment or on a nameplate of metal plastic, or other material fastened to the equipment by welding, riveting, or a permanent adhesive. The label must be designed to last the expected life-time of the equipment in the environment in which the equipment may be operated and must not be readily detachable.
- (2) Where a device is constructed in two or more sections connected by wires and marketed together, the statement specified in this Section is required to be affixed only to the main control unit.
- (3) When the device is so small or for such use that it is not practicable to place the statement specified in this Section on it, the information required by these paragraphs shall be placed in the instruction manual or pamphlet supplied to the user or, alternatively, shall be placed on the container in which the device is marketed. However, the FCC identifier or the unique identifier, as appropriate, must be displayed on the device.

7.2. SECTIONS 15.21 & 15.105 – INFORMATION TO USER

The users manual or instruction manual for an intentional or unintentional radiator shall caution the user that changes or modifications not expressly approved by the party responsible for compliance could void the user's authority to operate the equipment.

- (a) For a Class B digital device or peripheral, the instructions furnished the user shall include the following or similar statement, placed in a prominent location in the text of the manual.

NOTE: This equipment has been tested and found to comply with the limits for a Class B digital devices, pursuant to Part 15 of the FCC Rules. These limits are designed to provide reasonable protection against harmful interference in a residential installation. This equipment generates, uses, and can radiate radio frequency energy and, if not installed and used in accordance with the instruction manual, may cause harmful interference to radio communications. However, there is no guarantee that interference will not occur in a particular installation. If this equipment does cause harmful interference to radio or television reception, which can be determined by turning the equipment off and on, the user is encouraged to try to correct the interference by one of more of the following measures:

- ***Reorient or relocate the receiving antenna***
- ***Increase the separation between the equipment and receiver***

- **Connect the equipment into an outlet on a circuit different from that to which the receiver is connected.**
- **Consult the dealer or an experienced radio/TV technician for help.**

Warning: Changes or modifications not expressly approved by <manufacturer> could void the user's authority to operate the equipment.

7.3. SECTION 2.906 - VERIFICATION

- (a) A Verification is a procedure where the responsible party, as defined in Section 2.909, makes measurements or takes other necessary steps to ensure that the equipment complies with the appropriate technical standards. Submittal of a sample unit or representative data to the Commission demonstrating compliance is not required unless specifically requested pursuant to Section 2.1076 of this part.
- (b) Verification attaches to all items subsequently marketed by the responsible party which are identical, as define in Section 2.908 of this part, to the sample tested and found acceptable by the responsible party.

7.4. SECTION 2.909 – RESPONSIBLE PARTY

The following parties are responsible for the compliance of radio frequency equipment with the applicable standards:

- (c) In the case of the equipment subject to authorization under the Verification procedure:
- (1) The manufacturer or, if the equipment is assembled from individual component parts and the resulting system is subject to authorization under Verification, the assembler.
 - (2) If the equipment, by itself, is subject to Verification and the equipment is imported, the importer.

7.5. SECTION 2.945 – SAMPLING TEST OF EQUIPMENT COMPLIANCE

The Commission will, from time to time, request the responsible party to submit equipment subject to this chapter to determine the extent to which subsequent production of such equipment continues to comply with the data filed by the applicant (or on file with the responsible party for equipment subject to notification or a Verification). Shipping costs to the Commission's laboratory and return shall be borne by the responsible party.

7.6. SECTION 2.946 – PENALTY FOR FAILURE TO PROVIDE TEST SAMPLES AND DATA

- (a) Any responsible party, as defined in Section 2.909 of this chapter, or nay party who markets equipment subject to the provisions of this chapter, shall provide test sample(s) or data upon request by the Commission. Failure to comply with such a request with the time frames shown below may be cause for forfeiture, pursuant to Section 1.80 of Part 1 of this chapter, or other administrative sanctions such as suspending action on any applications for equipment authorization submitted by such party while the matter is being resolved.
- (1) When the equipment is subject to authorization under Verification, data shall be provided within 14 days of delivery of the request and test sample(s) shall be provided within 60 days of delivery of the request.

- (2) For all other devices, test sample(s) or data shall be provided within 60 days of the request.
- (b) In the case of the equipment involving harmful interference or safety of life or property, the Commission may specify that test samples subject to the provisions of this section be submitted within less than 60 days, but not less than 14 days. Failure to comply within the specified time period will be subject to the sanctions specified in paragraph (a) of this section.

7.7. SECTION 2.952 - LIMITATION ON VERIFICATION

- (a) Verification signifies that the manufacturer or importer has determined that the equipment has been shown to be capable of compliance with the applicable technical standards if no unauthorized change is made in the equipment and if the equipment is properly maintained and operated. Compliance with these standards shall not be construed to be a finding by the manufacturer or importer with respect to matters not encompassed by the Commission's rules.
- (b) Verification of the equipment by the manufacturer or importer is effective until a termination date is otherwise established by the Commission.
- (c) No person shall, in any advertising matter, brochure, etc., use or make reference to a verification in a deceptive or misleading manner or convey the impression that such verification reflects more than a determination by the manufacturer or importer that the device or product has been shown to be capable of compliance with the applicable technical standards of the Commission's Rules.

7.8. SECTION 2.953 - RESPONSIBILITY OF MANUFACTURER OR IMPORTER

- (a) In verifying compliance, the manufacturer or importer (in the case of imported equipment) warrants that each unit of the equipment marketed under the verification procedure will conform to the unit tested and found acceptable by the manufacturer or importer and that data on file with the manufacturer or importer continues to be representative of the equipment being produced under such verification within the variation that can be expected due to quantity production and testing on a statistical basis.
- (b) The importer of equipment subject to verification may upon receiving a written statement from the manufacturer that the equipment complies with the appropriate technical standards rely on the manufacturer or independent testing agency to verify compliance. The test records required by Section 2.955 however should be in English language and made available to the Commission upon a reasonable request.
- (c) In the case of transfer of control of equipment, as in the case of sale or merger of the grantee, the new manufacturer or importer shall bear the responsibility of continued compliance of the equipment.
- (d) Equipment verified by the manufacturer or importer shall be re-verified if the modification or change adversely affects the emanation characteristics of the modified equipment. The manufacturer or importer continues to bear the responsibility for continued compliance of subsequently produced equipment.

7.9. SECTION 2.954 - IDENTIFICATION

The identification of equipment subject to verification shall be consistent with current manufacturer or marketing practices: *Provided*, The manufacturer or importer maintains adequate identification records for each unit verified to facilitate positive identification of each equipment marketed.

7.10. SECTION 2.955 - RETENTION OF RECORDS

- (a) For each equipment subject to verification, the manufacturer (or importer) shall maintain the records listed below:
- (1) A record of the original design drawings and specifications and all changes that have been made that may affect compliance with the requirements of Section 2.953.
 - (2) A record of the procedures used for production inspection and testing (if tests were performed) to insure the conformance required by Section 2.953. (Statistical production line emission testing is not required).
- (b) The records listed in paragraphs (a) of this section shall be retained for two years after the manufacture of said equipment item has been permanently discontinued, or until the conclusion of an investigation or a proceeding if the manufacturer or importer is officially notified that an investigation or any other administrative proceeding involving his equipment has been instituted.

7.11. SECTION 2.956 - FCC INSPECTION & SUBMISSION OF EQUIPMENT FOR TESTING

- (a) Each manufacturer or importer of equipment subject to verification shall upon receipt of reasonable request submit to the Commission the records required by Section 2.955.
- (b) The Commission may require the manufacturer or importer of equipment subject to verification to submit one or more of sample units for measurements at the Commission's Laboratory.
- (c) In the event the manufacturer believes that shipment of the sample to the Commission's Laboratory is impractical because of the size or weight of the equipment, or the power requirement or for any other reason, the applicant may submit a written explanation why such shipment is impractical and should not be required.

7.12. SECTION 2.957 - SAMPLING TESTS OF EQUIPMENT COMPLIANCE

The Commission will from time to time, request the manufacturer or importer to submit to the FCC Laboratory in Columbia, Maryland, various equipment(s) for which verification has been made, to determine the extent to which subsequently produced units continue to comply with the applicable standards.