



SAR EVALUATION REPORT

For

Psion Teklogix

2100 Meadowvale Boulevard
Mississauga, Ontario, Canada L5N 7J9

FCC ID: GM37527CG23
IC ID: 2739D-7527CG23

This Report Concerns:		Product Name:	
<input checked="" type="checkbox"/> Original Report		The Benchmark in Hand-Held Computing	
Test Engineer:	Jimmy Nguyen		
Report No.:	R0804256-SAR		
Report Date:	2008-06-02		
Reviewed By:	Boni Baniqued		
Prepared By:	Bay Area Compliance Laboratories Corp. (BACL) 1274 Anvilwood Ave. Sunnyvale, CA 94089, USA Tel: (408) 732-9162 Fax: (408) 732-9164		

Note: This test report is for the customer shown above and their specific product only. It may not be duplicated or used in part without prior written consent from Bay Area Compliance Laboratories Corp. This report **must not** be used by the customer to claim product certification, approval, or endorsement by NVLAP or any agency of the U.S. Government.

DECLARATION OF COMPLIANCE SAR EVALUATION

Rule Part(s):	CFR 47 §2.1093	
Test Procedure(s):	FCC OET Bulletin 65 C; IEEE 1528-2003	
Device Category: Exposure Category:	Portable Device General Population/Uncontrolled Exposure	
Device Type:	Hand-Held Computing with Wi-Fi and Bluetooth	
Modulation Type:	DSSS, OFDM	
TX Frequency Range:	2412 – 2462 MHz	802.11b/g
	5150 – 5350; 5470-5725; 5725-5825 MHz	802.11a
Maximum Conducted Power Tested:	802.11b: 87.1 mw; 802.11g: 100 mw; 802.11a: 66.1 mw (FCC15.247); 802.11a: 28 mw (FCC15.407, 5150-5350 MHz) 802.11a: 38 mw (FCC15.407, 5470-5725 MHz)	
Antenna Type(s) Tested:	Integrate Antenna	
Battery Type (s) Tested:	Lithium-Ion Rechargeable 3.7 Vdc, 3000mAh	
Max. SAR Level(s) Measured:	2412-2462 MHZ 802.11b:0.033 W/Kg 2412-2462 MHZ 802.11g: 0.065 W/Kg 5180-5320 MHZ 802.11a: 0.151 W/Kg 5500-5700 MHZ 802.11a: 0.214 W/Kg 5745-5825 MHZ 802.11a: 0.060 W/Kg (1 g Body Tissue)	

This wireless device has been shown to be capable of compliance for localized specific absorption rate (SAR) for General Population/Uncontrolled Exposure limits specified in ANSI/IEEE Standards and has been tested in accordance with the measurement procedures specified in FCC OET 65 Supplement C.

The results and statements contained in this report pertain only to the device(s) evaluated.

Tested By:



Jimmy Nguyen

Testing Engineer

Bay Area Compliance Laboratories Corp.



EUT Photo

TABLE OF CONTENTS

REFERENCE, STANDARDS, AND GUIDELINES	5
SAR LIMITS	6
EUT DESCRIPTION	7
EUT PHOTO	7
FACILITIES AND ACCREDITATION	8
DESCRIPTION OF TEST SYSTEM	9
MEASUREMENT SYSTEM DIAGRAM	11
SYSTEM COMPONENTS	12
EUT TEST STRATEGY AND METHODOLOGY	20
TEST POSITIONS FOR DEVICE OPERATING NEXT TO A PERSON’S EAR	20
CHEEK/TOUCH POSITION	21
EAR/TILT POSITION	21
TEST POSITIONS FOR BODY-WORN AND OTHER CONFIGURATIONS	22
SAR EVALUATION PROCEDURE	23
DASY4 SAR EVALUATION PROCEDURE.....	24
TESTING EQUIPMENT	26
EQUIPMENTS LIST & CALIBRATION INFO	26
SAR MEASUREMENT SYSTEM VERIFICATION	27
SYSTEM ACCURACY VERIFICATION	27
SAR MEASUREMENT RESULTS	29
SAR BODY WORST-CASE TEST DATA	29
PPENDIX A – MEASUREMENT UNCERTAINTY	31
APPENDIX B – PROBE CALIBRATION CERTIFICATES	33
APPENDIX C – DIPOLE CALIBRATION CERTIFICATES	51
APPENDIX D - TEST SYSTEM VERIFICATIONS SCANS	68
LIQUID MEASUREMENT RESULT	68
APPENDIX E - EUT SCANS	73
APPENDIX F – CONDUCTED OUTPUT POWER MEASUREMENT	87
PROVISION APPLICABLE	87
TEST PROCEDURE	87
TEST EQUIPMENT LIST	87
TEST RESULTS	87
APPENDIX G – EUT TEST POSITION PHOTOS	89
EUT TOP SIDE TOUCHING TO THE FLAT PHANTOM	89
APPENDIX H– EUT PHOTO	90
EUT – FRONT SIDE VIEW	90
EUT – BOTTOM SIDE VIEW	90
EUT – LEFT SIDE VIEW	91

EUT – TOP SIDE VIEW 91
EUT – COVER OFF VIEW 92
EUT – BATTERY VIEW 92
APPENDIX I - INFORMATIVE REFERENCES..... 93

REFERENCE, STANDARDS, AND GUIDELINES

FCC:

The Report and Order requires routine SAR evaluation prior to equipment authorization of portable transmitter devices, including portable telephones. For consumer products, the applicable limit is 1.6 mw/g as recommended by the ANSI/IEEE standard C95.1-1992 [6] for an uncontrolled environment (Paragraph 65). According to the Supplement C of OET Bulletin 65 "Evaluating Compliance with FCC Guide-lines for Human Exposure to Radio frequency Electromagnetic Fields", released on Jun 29, 2001 by the FCC, the device should be evaluated at maximum output power (radiated from the antenna) under "worst-case" conditions for normal or intended use, incorporating normal antenna operating positions, device peak performance frequencies and positions for maximum RF energy coupling.

This report describes the methodology and results of experiments performed on wireless data terminal. The objective was to determine if there is RF radiation and if radiation is found, what is the extent of radiation with respect to safety limits. SAR (Specific Absorption Rate) is the measure of RF exposure determined by the amount of RF energy absorbed by human body (or its parts) – to determine how the RF energy couples to the body or head which is a primary health concern for body worn devices. The limit below which the exposure to RF is considered safe by regulatory bodies in North America is 1.6 mw/g average over 1 gram of tissue mass.

CE:

The order requires routine SAR evaluation prior to equipment authorization of portable transmitter devices, including portable telephones. For consumer products, the applicable limit is 2 mw/g as recommended by the EN50360 for an uncontrolled environment. According to the Standard, the device should be evaluated at maximum output power (radiated from the antenna) under "worst-case" conditions for normal or intended use, incorporating normal antenna operating positions, device peak performance frequencies and positions for maximum RF energy coupling.

This report describes the methodology and results of experiments performed on wireless data terminal. The objective was to determine if there is RF radiation and if radiation is found, what is the extent of radiation with respect to safety limits. SAR (Specific Absorption Rate) is the measure of RF exposure determined by the amount of RF energy absorbed by human body (or its parts) – to determine how the RF energy couples to the body or head which is a primary health concern for body worn devices. The limit below which the exposure to RF is considered safe by regulatory bodies in Europe is 2 mw/g average over 10 gram of tissue mass.

The test configurations were laid out on a specially designed test fixture to ensure the reproducibility of measurements. Each configuration was scanned for SAR. Analysis of each scan was carried out to characterize the above effects in the device.

There was no SAR of any concern measured on the device for any of the investigated configurations.

SAR Limits

FCC Limit (1g tissue)

EXPOSURE LIMITS	SAR (W/kg)	
	(General Population / Uncontrolled Exposure Environment)	(Occupational / Controlled Exposure Environment)
Spatial Average (averaged over the whole body)	0.08	0.4
Spatial Peak (averaged over any 1 g of tissue)	1.60	8.0
Spatial Peak (hands/wrists/feet/ankles averaged over 10 g)	4.0	20.0

CE Limit (10g tissue)

EXPOSURE LIMITS	SAR (W/kg)	
	(General Population / Uncontrolled Exposure Environment)	(Occupational / Controlled Exposure Environment)
Spatial Average (averaged over the whole body)	0.08	0.4
Spatial Peak (averaged over any 1 g of tissue)	2.0	10
Spatial Peak (hands/wrists/feet/ankles averaged over 10 g)	4.0	20.0

Population/Uncontrolled Environments are defined as locations where there is the exposure of individual who have no knowledge or control of their exposure.

Occupational/Controlled Environments are defined as locations where there is exposure that may be incurred by people who are aware of the potential for exposure (i.e. as a result of employment or occupation).

General Population/Uncontrolled environments Spatial Peak limit 1.6 W/kg (FCC) & 2 W/kg (CE) applied to the EUT.

EUT DESCRIPTION

This Bay Area Compliance Laboratories Corp. test report has been prepared on behalf of Psion Teklogix and their product, Model No.: 7527C G2 or the EUT (Equipment under Test) as referred to in the rest of this report.

**The data gathered are from Psion Teklogix sample provided by the manufacturer, serial number: B1793*

EUT Photo



Additional EUT photos in Exhibit H

Mechanical Description

The EUT is Hand-Held Computing with Wi-Fi and Bluetooth of metal and plastic construction that measures approximately 223 mm (L) x 975 mm (W) x 31 mm (H) and weighs approximately 455g.

FACILITIES AND ACCREDITATION

The test site used by Bay Area Compliance Laboratories Corp. (BACL) to collect data is located at 1274 Anvilwood Ave, Sunnyvale, California 94089, USA.

BACL is a National Institute of Standards and Technology (NIST) accredited laboratory under the National Voluntary Laboratory Accredited Program (Lab Code 200167-0).



The current scope of accreditations can be found at:

<http://ts.nist.gov/ts/htdocs/210/214/scopes/2001670.htm>

DESCRIPTION OF TEST SYSTEM

These measurements were performed with the automated near-field scanning system DASY4 from Schmid & Partner Engineering AG (SPEAG) which is the fourth generation of the system shown in the figure hereinafter:



The system is based on a high precision robot (working range greater than 0.9m), which positions the probes with a positional repeatability of better than $\pm 0.02\text{mm}$. Special E- and H-field probes have been developed for measurements close to material discontinuity, the sensors of which are directly loaded with a Schottky diode and connected via highly resistive lines to the data acquisition unit.

The SAR measurements were conducted with the dosimetric probe ET3DV6 SN: 1604 (manufactured by SPEAG), designed in the classical triangular configuration and optimized for dosimetric evaluation. The probe has been calibrated according to the procedure with accuracy of better than $\pm 10\%$. The spherical isotropy was evaluated with the procedure and found to be better than $\pm 0.25\text{dB}$.

The phantom used was the Generic Twin Phantom. The ear was simulated as a spacer of 4 mm thickness between the earpiece of the phone and the tissue simulating liquid. The Tissue simulation liquid used for each test is in according with the FCC OET65 supplement C as listed below.

Ingredients (% by weight)	Frequency (MHz)									
	450		835		915		1900		2450	
Tissue Type	Head	Body	Head	Body	Head	Body	Head	Body	Head	Body
Water	38.56	51.16	41.45	52.4	41.05	56.0	54.9	40.4	62.7	73.2
Salt (NaCl)	3.95	1.49	1.45	1.4	1.35	0.76	0.18	0.5	0.5	0.04
Sugar	56.32	46.78	56.0	45.0	56.5	41.76	0.0	58.0	0.0	0.0
HEC	0.98	0.52	1.0	1.0	1.0	1.21	0.0	1.0	0.0	0.0
Bactericide	0.19	0.05	0.1	0.1	0.1	0.27	0.0	0.1	0.0	0.0
Triton X-100	0.0	0.0	0.0	0.0	0.0	0.0	0.0	0.0	36.8	0.0
DGBE	0.0	0.0	0.0	0.0	0.0	0.0	44.92	0.0	0.0	26.7
Dielectric Constant	43.42	58.0	42.54	56.1	42.0	56.8	39.9	54.0	39.8	52.5
Conductivity (S/m)	0.85	0.83	0.91	0.95	1.0	1.07	1.42	1.45	1.88	1.78

IEEE SCC-34/SC-2 P1528 Recommended Tissue Dielectric Parameters

Frequency (MHz)	Head		Body	
	ϵ_r	σ (S/m)	ϵ_r	σ (S/m)
150	52.3	0.76	61.9	0.80
300	45.3	0.87	58.2	0.92
450	43.5	0.87	56.7	0.94
835	41.5	0.90	55.2	0.97
900	41.5	0.97	55.0	1.05
915	41.5	0.98	55.0	1.06
1450	40.5	1.20	54.0	1.30
1610	40.3	1.29	53.8	1.40
1800-2000	40.0	1.40	53.3	1.52
2450	39.2	1.80	52.7	1.95
3000	38.5	2.40	52.0	2.73
5800	35.3	5.27	48.2	6.00

Measurement System Diagram

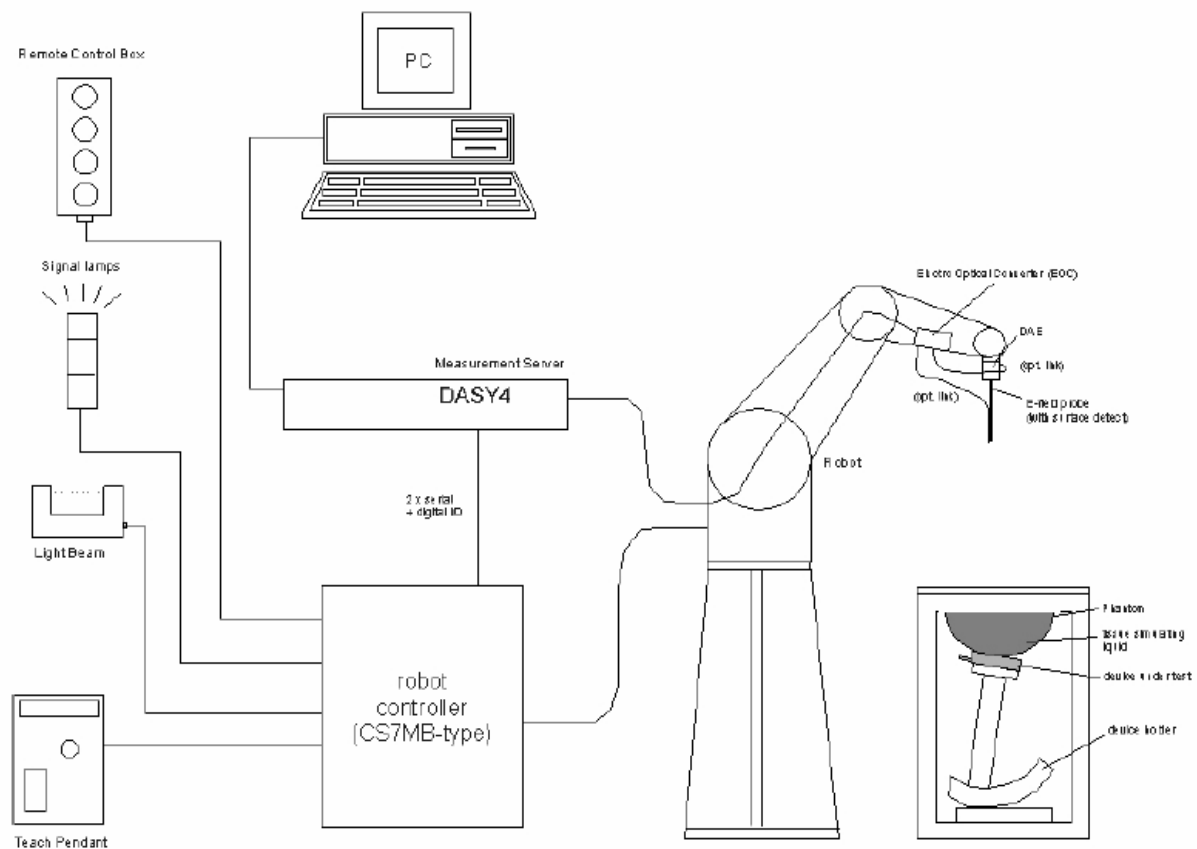

The DASY4 system for performing compliance tests consists of the following items:

- A standard high precision 6-axis robot (Stäubli RX family) with controller, teach pendant and software. An arm extension for accommodating the data acquisition electronics (DAE).
- A dosimetric probe, i.e., an isotropic E-field probe optimized and calibrated for usage in tissue simulating liquid. The probe is equipped with an optical surface detector system.
- A Data Acquisition Electronics (DAE) which performs the signal amplification, signal multiplexing, AD-conversion, offset measurements, mechanical surface detection, collision detection, etc. The unit is battery powered with standard or rechargeable batteries. The signal is optically transmitted to the EOC.
- The Electro-Optical Converter (EOC) performs the conversion between optical and electrical of the signals for the digital communication to the DAE and for the analog signal from the optical surface detection. The EOC is connected to the measurement server.
- The function of the measurement server is to perform the time critical tasks such as signal filtering, control of the robot operation and fast movement interrupts.
- A probe alignment unit which improves the (absolute) accuracy of the probe positioning.

- A computer operating Windows 2000 or Windows XP.
- DASY4 software.
- Remote control with teach pendant and additional circuitry for robot safety such as warning lamps, etc.
- The SAM twin phantom enabling testing left-hand and right-hand usage.
- The device holder for handheld mobile phones.
- Tissue simulating liquid mixed according to the given recipes.
- Validation dipole kits allowing to validate the proper functioning of the system.

System Components

- DASY4 Measurement Server
- Data Acquisition Electronics
- Probes
- Light Beam Unit
- Medium
- SAM Twin Phantom
- Device Holder for SAM Twin Phantom
- System Validation Kits
- Robot

DASY4 Measurement Server

The DASY4 measurement server is based on a PC/104 CPU board with a 166MHz low-power Pentium, 32MB chip disk and 64MB RAM. The necessary circuits for communication with either the DAE4 (or DAE3) electronic box as well as the 16-bit AD-converter system for optical detection and digital I/O interface are contained on the DASY4 I/O-board, which is directly connected to the PC/104 bus of the CPU board.



The measurement server performs all real-time data evaluation for field measurements and surface detection, controls robot movements and handles safety operation. The PC-operating system cannot interfere with these time critical processes. All connections are supervised by a watchdog, and disconnection of any of the cables to the measurement server will automatically disarm the robot and disable all program-controlled robot movements. Furthermore, the measurement server is equipped with two expansion slots which are reserved for future applications. Please note that the expansion slots do not have a standardized pinout and therefore only the expansion cards provided by SPEAG can be inserted. Expansion cards from any other supplier could seriously damage the measurement server.

Data Acquisition Electronics

The data acquisition electronics DAE3 consists of a highly sensitive electrometer grade preamplifier with auto-zeroing, a channel and gain-switching multiplexer, a fast 16 bit AD-converter and a command decoder and control logic unit. Transmission to the measurement server is accomplished through an optical downlink for data and status information as well as an optical uplink for commands and the clock.



Probes

The DASY system can support many different probe types.

Dosimetric Probes: These probes are specially designed and calibrated for use in liquids with high permittivities. They should not be used in air, since the spherical isotropy in air is poor (± 2 dB). The dosimetric probes have special calibrations in various liquids at different frequencies.

Free Space Probes: These are electric and magnetic field probes specially designed for measurements in free space. The z-sensor is aligned to the probe axis and the rotation angle of the x-sensor is specified. This allows the DASY system to automatically align the probe to the measurement grid for field component measurement. The free space probes are generally not calibrated in liquid. (The H-field probes can be used in liquids without any change of parameters.)

Temperature Probes: Small and sensitive temperature probes for general use. They use a completely different parameter set and different evaluation procedures. Temperature rise features allow direct SAR evaluations with these probes.

ET3DV6 Probe Specification

Construction Symmetrical design with triangular core
 Built-in optical fiber for surface detection System
 Built-in shielding against static charges
 Calibration In air from 10 MHz to 2.5 GHz
 In brain and muscle simulating tissue at
 Frequencies of 450 MHz, 900 MHz and
 1.8 GHz (accuracy $\pm 8\%$)
 Frequency 10 MHz to > 6 GHz; Linearity: ± 0.2 dB
 (30 MHz to 3 GHz)
 Directivity ± 0.2 dB in brain tissue (rotation around
 probe axis)
 ± 0.4 dB in brain tissue (rotation normal probe axis)
 Dynamic 5 mw/g to > 100 mw/g;
 Range Linearity: ± 0.2 dB
 Surface ± 0.2 mm repeatability in air and clear liquids
 Detection over diffuse reflecting surfaces.
 Dimensions Overall length: 330 mm
 Tip length: 16 mm

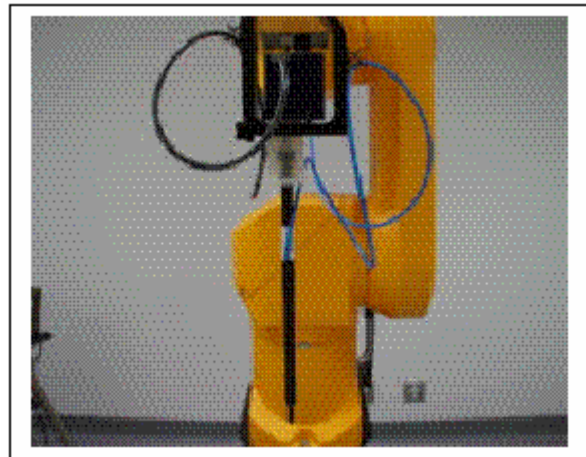

Photograph of the probe

Body diameter: 12 mm
 Tip diameter: 6.8 mm
 Distance from probe tip to dipole centers: 2.7 mm
 Application General dosimetric up to 3 GHz
 Compliance tests of mobile phones
 Fast automatic scanning in arbitrary phantoms

The SAR measurements were conducted with the dosimetric probe ET3DV6 designed in the classical triangular configuration and optimized for dosimetric evaluation. The probe is constructed using the thick film technique; with printed resistive lines on ceramic substrates. The probe is equipped with an optical multi-fiber line ending at the front of the probe tip. It is connected to the EOC box the robot arm and provides an automatic detection of the phantom surface. Half of the fibers are connected to a pulsed infrared transmitter, the other half to a synchronized receiver. As the probe approaches the surface, the reflection from the surface produces a coupling from the transmitting to the receiving fibers. This reflection increases first during the approach, reaches maximum and then decreases. If the probe is flatly touching the surface, the coupling is zero. The distance of the coupling maximum to the surface is independent of the surface reflectivity and largely independent of the surface to probe angle. The DASY3 software reads the reflection during a software approach and looks for the maximum using a 2nd order fitting. The approach is stopped when reaching the maximum.

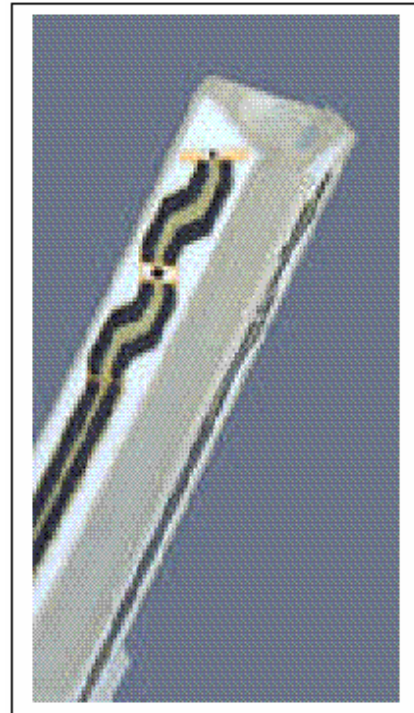

on

**Inside view of
 ET3DV6 E-field Probe**

E-Field Probe Calibration Process

Each probe is calibrated according to a dosimetric assessment procedure described in [6] with accuracy better than +/- 10%. The spherical isotropy was evaluated with the procedure described in [7] and found to be better than +/-0.25dB. The sensitivity parameters (NormX, NormY, NormZ), the diode compression parameter (DCP) and the conversion factor (ConvF) of the probe are tested.

The free space E-field from amplified probe outputs is determined in a test chamber. This is performed in a TEM cell for frequencies bellow 1 GHz, and in a waveguide above 1 GHz for free space. For the free space calibration, the probe is placed in the volumetric center of the cavity and at the proper orientation with the field. The probe is then rotated 360 degrees.

E-field temperature correlation calibration is performed in a flat phantom filled with the appropriate simulated brain tissue. The measured free space E-field in the medium correlates to temperature rise in dielectric medium. For temperature correlation calibration a RF transparent thermistor-based temperature probe is used in conjunction with the E-field probe.

Data Evaluation

The DASY4 post-processing software (SEMCAD) automatically executes the following procedures to calculate the field units from the microvolt readings at the probe connector. The parameters used in the evaluation are stored in the configuration modules of the software:

Probe parameters: - Sensitivity	Normi, ai0, ai1, ai2
- Conversion factor	ConvFi

- Diode compression point dcp_i

Device parameters: - Frequency f
 - Crest factor cf

Media parameters: - Conductivity σ
 - Density ρ

These parameters must be set correctly in the software. They can be found in the component documents or they can be imported into the software from the configuration files issued for the DASY components. In the direct measuring mode of the multi-meter option, the parameters of the actual system setup are used. In the scan visualization and export modes, the parameters stored in the corresponding document files are used.

The first step of the evaluation is a linearization of the filtered input signal to account for the compression characteristics of the detector diode. The compensation depends on the input signal, the diode type and the DC-transmission factor from the diode to the evaluation electronics. If the exciting field is pulsed, the crest factor of the signal must be known to correctly compensate for peak power. The formula for each channel can be given as:

$$V_i = U_i + U_i^2 \cdot \frac{cf}{dcp_i}$$

With V_i = compensated signal of channel i (i=x, y, z)
 U_i = input signal of channel i (i=x, y, z)
 cf = crest factor of exciting field (DASY parameter)
 dcp_i = diode compression point (DASY parameter)

From the compensated input signals the primary field data for each channel can be evaluated:

E – fieldprobes :
$$E_i = \sqrt{\frac{V_i}{Norm_i \cdot ConvF}}$$

H – fieldprobes :
$$H_i = \sqrt{V_i} \cdot \frac{a_{i0} + a_{i1}f + a_{i2}f^2}{f}$$

With V_i = compensated signal of channel i (i=x, y, z)
 $Norm_i$ = sensor sensitivity of channel i (i=x, y, z)
 $\mu V / (V/m)^2$ for E-field probes
 $ConvF$ = sensitivity enhancement in solution
 a_{ij} = sensor sensitivity factors for H-field probes
 f = carrier frequency [GHz]
 E_i = electric field strength of channel i in V/m
 H_i = diode compression point (DASY parameter)

The RSS value of the field components gives the total field strength (Hermitian magnitude):

$$E_{tot} = \sqrt{E_x^2 + E_y^2 + E_z^2}$$

The primary field data are used to calculate the derived field units.

$$SAR = E_{tot}^2 \cdot \frac{\sigma}{\rho \cdot 1'000}$$

With SAR = local specific absorption rate in mW/g

E_{tot} = total field strength in V/m

σ = conductivity in [mho/m] or [Siemens/m]

ρ = equivalent tissue density in g/cm³

Note that the density is normally set to 1, to account for actual brain density rather than the density of the simulation liquid.

Light Beam Unit

The light beam switch allows automatic "tooling" of the probe. During the process, the actual position of the probe tip with respect to the robot arm is measured, as well as the probe length and the horizontal probe offset. The software then corrects all movements, so that the robot coordinates are valid for the probe tip. The repeatability of this process is better than 0.1 mm. If a position has been taught with an aligned probe, the same position will be reached with another aligned probe within 0.1 mm, even if the other probe has different dimensions. During probe rotations, the probe tip will keep its actual position.

Medium

Parameters

The parameters of the tissue simulating liquid strongly influence the SAR in the liquid. The parameters for the different frequencies are defined in the corresponding compliance standards (e.g., EN 50361, IEEE 1528-2003).

Parameter measurements

Several measurement systems are available for measuring the dielectric parameters of liquids:

- The open coax test method (e.g., HP85070 dielectric probe kit) is easy to use, but has only moderate accuracy. It is calibrated with open, short, and deionized water and the calibrations a critical process.
- The transmission line method (e.g., model 1500T from DAMASKOS, INC.) measures the transmission and reflection in a liquid filled high precision line. It needs standard two port calibration and is probably more accurate than the open coax method.
- The reflection line method measures the reflection in a liquid filled shorted precision lined, the method is not suitable for these liquids because of its low sensitivity.
- The slotted line method scans the field magnitude and phase along a liquid filled line. The evaluation is straight forward and only needs a simple response calibration. The method is very accurate, but can only be used in high loss liquids and at frequencies above 100 to 200MHz. Cleaning the line can be tedious.

SAM Twin Phantom

The SAM twin phantom is a fiberglass shell phantom with 2mm shell thickness (except the ear region where shell thickness increases to 6mm). It has three measurement areas:

- Left hand
- Right hand
- Flat phantom

The phantom table comes in two sizes: A 100 x 50 x 85 cm (L x W x H) table for use with free standing robots (DASY4 professional system option) or as a second phantom and a 100 x 75 x 85 cm(L x W x H) table with reinforcements for table mounted robots (DASY4 compact system option) .

The bottom plate contains three pair of bolts for locking the device holder. The device holder positions are adjusted to the standard measurement positions in the three sections. Only one device holder is necessary if two phantoms are used (e.g., for different liquids) A white cover is provided to tap the phantom during o_-periods to prevent water evaporation and changes in the liquid parameters. Free space scans of devices on the cover are possible. On the phantom top, three reference markers are provided to identify the phantom position with respect to the robot.

The phantom can be used with the following tissue simulating liquids:

- Water-sugar based liquids can be left permanently in the phantom. Always cover the liquid if the system is not used, otherwise the parameters will change due to water evaporation.
- Glycol based liquids should be used with care. As glycol is a softener for most plastics, the liquid should be taken out of the phantom and the phantom should be dried when the system is not used (desirable at least once a week).
- Do not use other organic solvents without previously testing the phantom resistiveness.



Device Holder for SAM Twin Phantom

The SAR in the phantom is approximately inversely proportional to the square of the distance between the source and the liquid surface. For a source in 5mm distance, a positioning uncertainty of $\pm 0.5\text{mm}$ would produce a SAR uncertainty of $\pm 20\%$. An accurate device positioning is therefore crucial for accurate and repeatable measurements. The positions, in which the devices must be measured, are defined by the standards. The DASY device holder is designed to cope with different positions given in the standard. It has two scales for the device rotation (with respect to the body axis) and the device inclination (with respect to the line between the ear reference points). The rotation centers for both scales are the ear reference point (ERP). Thus the device needs no repositioning when changing the angles.



The DASY device holder has been made out of low-loss POM material having the following dielectric parameters: relative permittivity $\epsilon_r=3$ and loss tangent $\tan \delta=0.02$. The amount of dielectric material has been reduced in the closest vicinity of the device, since measurements have suggested that the influence of the clamp on the test results could thus be lowered.

System Validation Kits

Each DASY system is equipped with one or more system validation kits. These units, together with the predefined measurement procedures within the DASY software, enable the user to conduct the system performance check and system validation. For that purpose a well defined SAR distribution in the flat section of the SAM twin phantom is produced.

System validation kit includes a dipole, tripod holder to fix it underneath the flat phantom and a corresponding distance holder. Dipoles are available for the variety of frequencies between 300MHz and 6 GHz (dipoles for other frequencies or media and other calibration conditions are available upon request).

The dipoles are highly symmetric and matched at the center frequency for the specified liquid and distance to the flat phantom (or flat section of the SAM-twin phantom). The accurate distance between the liquid surface and the dipole center is achieved with a distance holder that snaps on the dipole.

Robot

The DASY4 system uses the high precision industrial robots RX60L, RX90 and RX90L, as well as the RX60BL and RX90BL types out of the newer series from Stäubli SA (France). The RX robot series offers many features that are important for our application:

- High precision (repeatability 0.02mm)
- High reliability (industrial design)
- Low maintenance costs (virtually maintenance-free due to direct drive gears; no belt drives)
- Jerk-free straight movements (brushless synchrony motors; no stepper motors)
- Low ELF interference (the closed metallic construction shields against motor control fields)

For the newly delivered DASY4 systems as well as for the older DASY3 systems delivered since 1999, the CS7MB robot controller version from Stäubli is used. Previously delivered systems have either a CS7 or CS7M controller; the differences to the CS7MB are mainly in the hardware, but some procedures in the robot software from Stäubli are also not completely the same. The following descriptions about robot hard- and software correspond to CS7MB controller with software version 13.1 (edit S5). The actual commands, procedures and configurations, also including details in hardware, might differ if an older robot controller is in use. In this case please also refer to the Stäubli manuals for further information.



EUT TEST STRATEGY AND METHODOLOGY

Test Positions for Device Operating Next to a Person’s Ear

This category includes most wireless handsets with fixed, retractable or internal antennas located toward the top half of the device, with or without a foldout, sliding or similar keypad cover. The handset should have its earpiece located within the upper ¼ of the device, either along the centerline or off-centered, as perceived by its users. This type of handset should be positioned in a normal operating position with the “test device reference point” located along the “vertical centerline” on the front of the device aligned to the “ear reference point”. The “test device reference point” should be located at the same level as the center of the earpiece region. The “vertical centerline” should bisect the front surface of the handset at its top and bottom edges. A “ear reference point” is located on the outer surface of the head phantom on each ear spacer. It is located 1.5 cm above the center of the ear canal entrance in the “phantom reference plane” defined by the three lines joining the center of each “ear reference point” (left and right) and the tip of the mouth.

A handset should be initially positioned with the earpiece region pressed against the ear spacer of a head phantom. For the SCC-34/SC-2 head phantom, the device should be positioned parallel to the “N-F” line defined along the base of the ear spacer that contains the “ear reference point”. For interim head phantoms, the device should be positioned parallel to the cheek for maximum RF energy coupling. The “test device reference point” is aligned to the “ear reference point” on the head phantom and the “vertical centerline” is aligned to the “phantom reference plane”. This is called the “initial ear position”. While maintaining these three alignments, the body of the handset is gradually adjusted to each of the following positions for evaluating SAR:

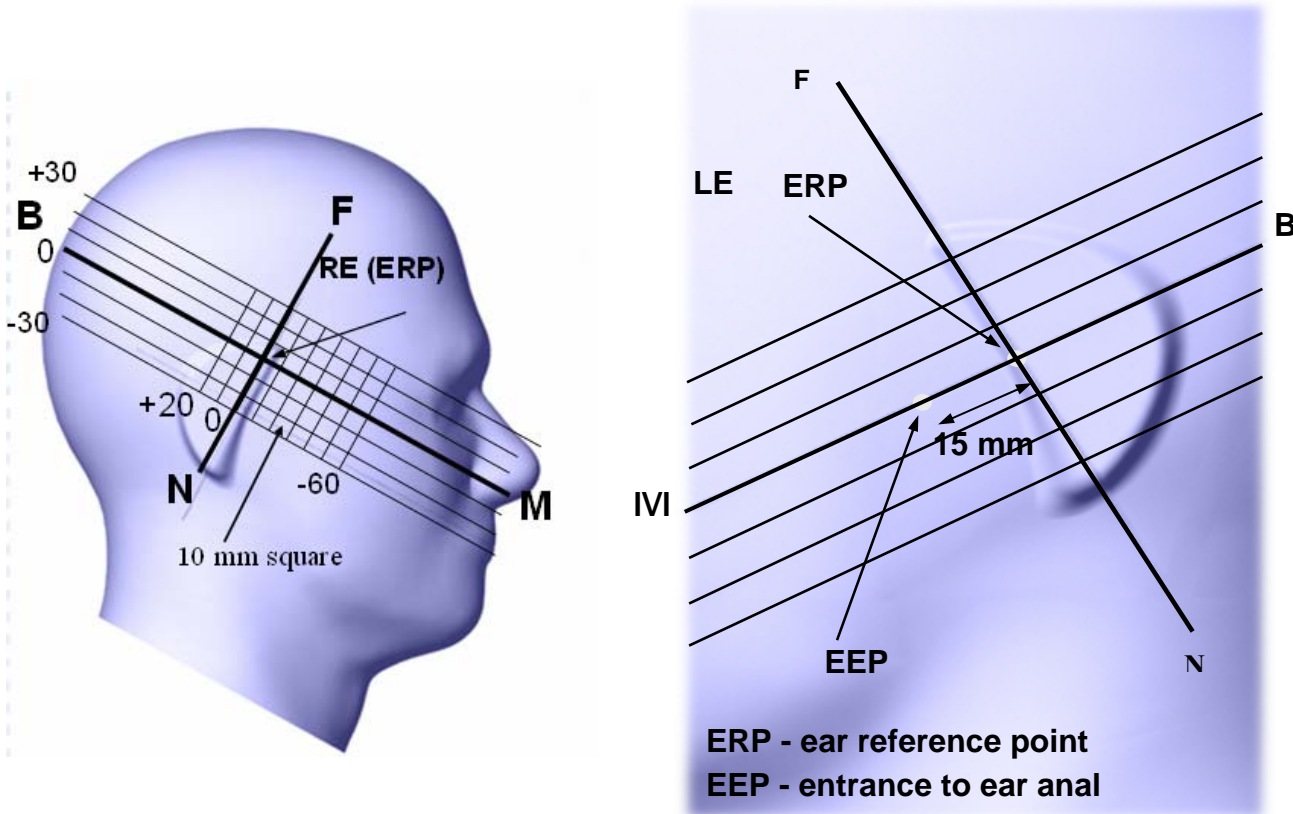

Cheek/Touch Position

The device is brought toward the mouth of the head phantom by pivoting against the “ear reference point” or along the “N-F” line for the SCC-34/SC-2 head phantom.

This test position is established:

- When any point on the display, keypad or mouthpiece portions of the handset is in contact with the phantom.(or) When any portion of a foldout, sliding or similar keypad cover opened to its intended self-adjusting normal use position is in contact with the cheek or mouth of the phantom.

For existing head phantoms – when the handset loses contact with the phantom at the pivoting point, rotation should continue until the device touches the cheek of the phantom or breaks its last contact from the ear spacer.

Check /Touch Position

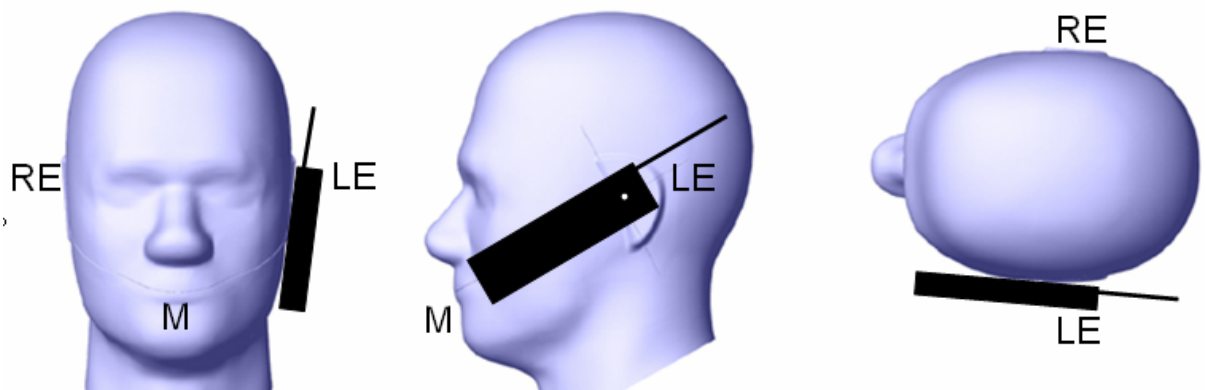

Ear/Tilt Position

With the handset aligned in the “Cheek/Touch Position”:

- 1) If the earpiece of the handset is not in full contact with the phantom’s ear spacer (in the “Cheek/Touch position”) and the peak SAR location for the “Cheek/Touch” position is located at the ear spacer region or corresponds to the earpiece region of the handset, the device should be returned to the “initial ear position” by rotating it away from the mouth until the earpiece is in full contact with the ear spacer.
- 2) (otherwise) The handset should be moved (translated) away from the cheek perpendicular to the line passes through both “ear reference points” (note: one of these ear reference points may not physically exist on a split head model) for approximate 2-3 cm. While it is in this position, the device handset is tilted away from the mouth with respect to the “test device reference point” until the inside angle between the vertical centerline on the front surface of the phone and the horizontal line passing through the ear reference point is by 15 80°. After the tilt, it is then moved (translated) back toward the head perpendicular to the line passes through both “ear reference points” until the device touches the phantom or the ear spacer. If the antenna touches the head first, the positioning process should be repeated with a tilt angle less than 15 80° so that the device and its antenna would touch the phantom simultaneously. This test position may require a device holder or positioner to achieve the translation and tilting with acceptable positioning repeatability.

If a device is also designed to transmit with its keypad cover closed for operating in the head position, such positions should also be considered in the SAR evaluation. The device should be tested on the left and right side of the head phantom in the “Cheek/Touch” and “Ear/Tilt” positions. When applicable, each configuration should be tested with the antenna in its fully extended and fully retracted positions. These test configurations should be tested at the high, middle and low frequency channels of each operating mode; for example, AMPS, CDMA, and TDMA. If the SAR measured at the middle channel for each test configuration (left, right, Cheek/Touch, Tile/Ear, extended and retracted) is at least 2.0 dB lower than the SAR limit, testing at the high and low channels is optional for such test configuration(s). If the transmission band of the test device is less than 10 MHz, testing at the high and low frequency channels is optional.

Ear /Tilt 15° Position

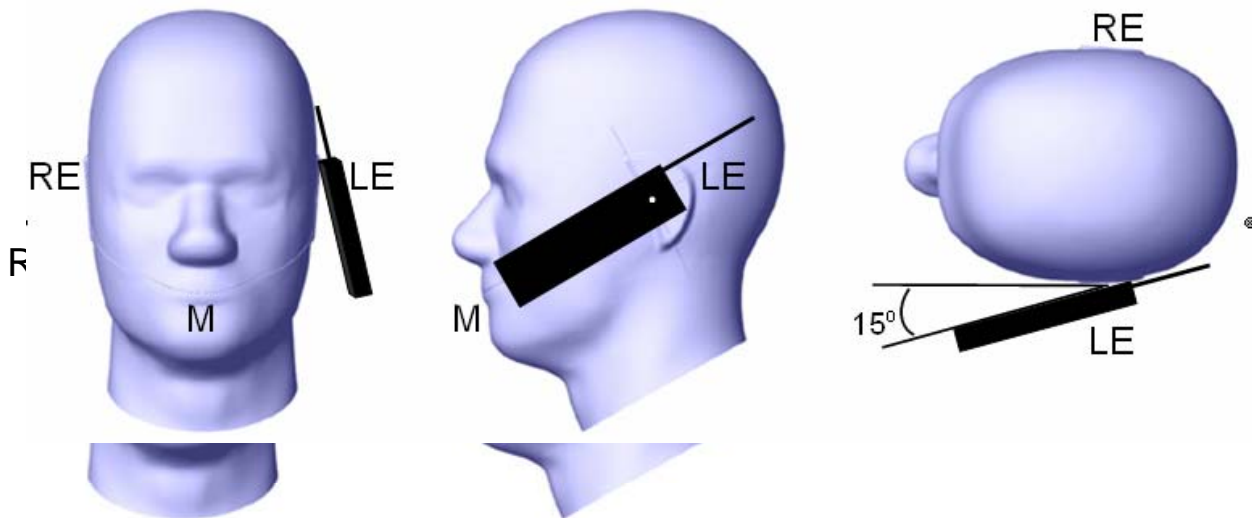

Test positions for body-worn and other configurations

Body-worn operating configurations should be tested with the belt-clips and holsters attached to the device and positioned against a flat phantom in normal use configurations. Devices with a headset output should be tested with a headset connected to the device. When multiple accessories that do not contain metallic components are supplied with the device, the device may be tested with only the accessory that dictates the closest spacing to the body. When multiple accessories that contain metallic components are supplied with the device, the device must be tested with each accessory that contains a unique metallic component. If multiple accessories share an identical metallic component (e.g., the same metallic belt-clip used with different holsters with no other metallic components), only the accessory that dictates the closest spacing to the body must be tested.

Body-worn accessories may not always be supplied or available as options for some devices that are intended to be authorized for body-worn use. A separation distance of 1.5 cm between the back of the device and a flat phantom is recommended for testing body-worn SAR compliance under such circumstances. Other separation distances may be used, but they should not exceed 2.5 cm. In these cases, the device may use body-worn accessories that provide a separation distance greater than that tested for the device provided however that the accessory contains no metallic components.

SAR Evaluation Procedure

The evaluation was performed with the following procedure:

- Step 1:** Measurement of the SAR value at a fixed location above the ear point or central position was used as a reference value for assessing the power drop. The SAR at this point is measured at the start of the test and then again at the end of the testing.
- Step 2:** The SAR distribution at the exposed side of the head was measured at a distance of 4 mm from the inner surface of the shell. The area covered the entire dimension of the head or EUT and the horizontal grid spacing was 15 mm x 15 mm. Based on these data, the area of the maximum absorption was determined by spline interpolation. The first Area Scan covers the entire dimension of the EUT to ensure that the hotspot was correctly identified.
- Step 3:** Around this point, a volume of 30 mm x 30 mm x 21 mm was assessed by measuring 5 x 5 x 7 points. On the basis of this data set, the spatial peak SAR value was evaluated under the following procedure:
1. The data at the surface were extrapolated, since the center of the dipoles is 1.2 mm away from the tip of the probe and the distance between the surface and the lowest measuring point is 1.3 mm. The extrapolation was based on a least square algorithm. A polynomial of the fourth order was calculated through the points in z-axes. This polynomial was then used to evaluate the points between the surface and the probe tip.
 2. The maximum interpolated value was searched with a straightforward algorithm. Around this maximum the SAR values averaged over the spatial volumes (1 g or 10 g) were computed by the 3D-Spline interpolation algorithm. The 3D-Spline is composed of three one dimensional splines with the "Not a knot"-condition (in x, y and z-directions). The volume was integrated with the trapezoidal-algorithm. One thousand points (10 x 10 x 10) were interpolated to calculate the averages.
 3. All neighboring volumes were evaluated until no neighboring volume with a higher average value was found.
- Step 4:** Re-measurement of the SAR value at the same location as in Step 1. If the value changed by more than 5%, the evaluation was repeated.

DASY4 SAR Evaluation Procedure

Step 1: Power Reference Measurement

The Power Reference Measurement and Power Drift Measurement jobs are useful jobs for monitoring the power drift of the device under test in the batch process. Both jobs measure the field at a specified reference position, at a selectable distance from the phantom surface. The reference position can be either the selected section's grid reference point or a user point in this section. The reference job projects the selected point onto the phantom surface, orients the probe perpendicularly to the surface, and approaches the surface using the selected detection method. The Minimum distance of probe sensors to surface determines the closest measurement point to phantom surface. By default, the Minimum distance of probe sensors to surface is 4mm. This distance can be modified by the user, but cannot be smaller than the Distance of sensor calibration points to probe tip as defined in the probe properties (for example, 2.7mm for an ET3DV6 probe type).

Step 2: Area Scan

The Area Scan is used as a fast scan in two dimensions to find the area of high field values, before doing a finer measurement around the hot spot. The sophisticated interpolation routines implemented in DASY4 software can find the maximum locations even in relatively coarse grids.

The scanning area is defined by an editable grid. This grid is anchored at the grid reference point of the selected section in the phantom. When the Area Scan's property sheet is brought-up, grid settings can be edited by a user.

When an Area Scan has measured all reachable points, it computes the field maxima found in the scanned area, within a range of the global maximum. The range (in dB) is specified in the standards for compliance testing. For example, a 2 dB range is required in IEEE 1528-2003, EN50361 and IEC 62209 standards, whereby 3 dB is a requirement when compliance is assessed in accordance with the ARIB standard (Japan). If only one Zoom Scan follows the Area Scan, then only the absolute maximum will be taken as reference. For cases where multiple maximums are detected, the number of Zoom Scans has to be increased accordingly.

After measurement is completed, all maxima and their coordinates are listed in the Results property page. The maximum selected in the list is highlighted in the 3-D view. For the secondary maxima returned from an Area Scan, the user can specify a lower limit (peak SAR value), in addition to the Find secondary maxima within x dB condition. Only the primary maximum and any secondary maxima within x dB from the primary maximum and above this limit will be measured.

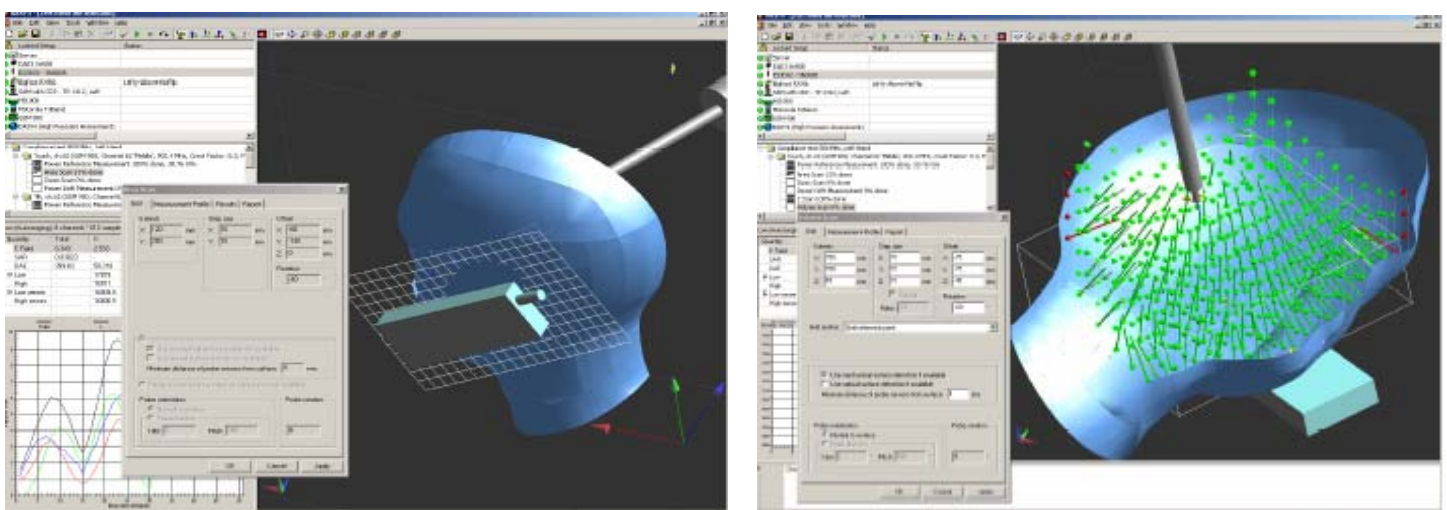

Step 3: Zoom Scan

Zoom Scans are used to assess the peak spatial SAR values within a cubic averaging volume containing 1 g and 10 g of simulated tissue. The default Zoom Scan measures 5 x 5 x 7 points within a cube whose base faces are centered around the maxima found in a preceding area scan job within the same procedure. When the measurement is done, the Zoom Scan evaluates the averaged SAR for 1 g and 10 g and displays these values next to the job's label.

Step 4: Power drift measurement

The Power Drift Measurement job measures the field at the same location as the most recent power reference measurement job within the same procedure, and with the same settings. The Power Drift Measurement gives the field difference in dB from the reading conducted within the last Power Reference Measurement. Several drift measurements are possible for one reference measurement.

This allows a user to monitor the power drift of the device under test within a batch process. The measurement procedure is the same as Step 1.

Step 5: Z-Scan

The Z Scan job measures points along a vertical straight line. The line runs along the Z axis of a one-dimensional grid. A user can anchor the grid to the section reference point, to any defined user point or to the current probe location. As with any other grids, the local Z axis of the anchor location establishes the Z axis of the grid.

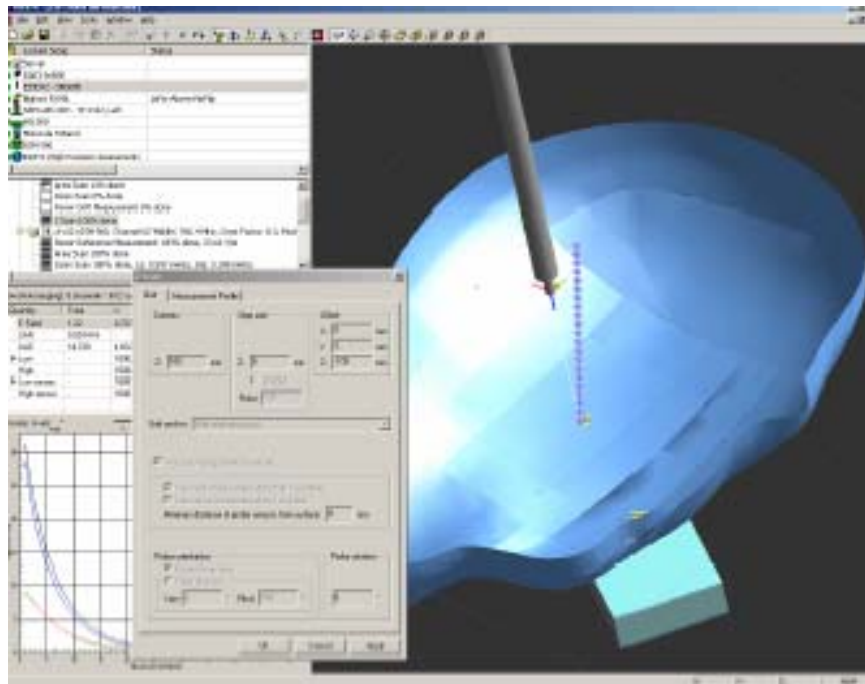

TESTING EQUIPMENT

Equipments List & Calibration Info

Type / Model	Cal. Due Date	S/N:
DASY4 Professional Dosimetric System	N/A	N/A
Robot RX60L	N/A	CS7MBSP / 467
Robot Controller	N/A	F01/5J72A1/A/01
Dell Computer Demension 3000	N/A	N/A
SPEAG EDC3	N/A	N/A
SPEAG DAE3	2008-11-08	456
DASY4 Measurement Server	N/A	1176
SPEAG E-Field Probe ET3DV6	2008-08-28	1604
SPEAG E-Field Probe EX3DV4	2008-09-10	3619
Antenna Dipole D-2450-S-1	2008-08-28	BCL-141
Antenna Dipole D5100V2	2008-11-08	1001
SPEAG Generic Twin Phantom	N/A	N/A
SPEAG Light Alignment Sensor	N/A	278
Phone Holder	N/A	N/A
Agilent, Spectrum Analyzer E4440A	2009-04-28	MY44303352
Microwave Amp. 8349A	N/A	2644A02662
Agilent, Wireless Communications Test Set 8960 Series 10 E5515C	2008-8-8	GB44051221
Dielectric Probe Kit HP85070A	N/A	US99360201
Agilent, Signal Generator, 8648C	2008-12-13	3347M00143
Amplifier, ST181-20	N/A	E012-0101
Antenna, Horn SAS-200/571	2008-4-20	A052704

SAR MEASUREMENT SYSTEM VERIFICATION

System Accuracy Verification

Prior to the assessment, the system validation kit was used to test whether the system was operating within its specifications of $\pm 10\%$. The validation results are tabulated below. And also the corresponding SAR plot is attached as well in the SAR plots files.

IEEE P1528 recommended reference value for Head

Frequency (MHz)	1 g SAR	10 g SAR	Local SAR at surface (above feed point)	Local SAR at surface (v=2cm offset from feed point)
300	3.0	2.0	4.4	2.1
450	4.9	3.3	7.2	3.2
835	9.5	6.2	14.1	4.9
900	10.8	6.9	16.4	5.4
1450	29.0	16.0	50.2	6.5
1800	38.1	19.8	69.5	6.8
1900	39.7	20.5	72.1	6.6
2000	41.1	21.1	74.6	6.5
2450	52.4	24.0	104.2	7.7
3000	63.8	25.7	140.2	9.5

Reference SAR Value for 5GHz Band

f (MHz)	Head Tissue			Body Tissue		
	SAR _{1g}	SAR _{10g}	SAR _{peak}	SAR _{1g}	SAR _{10g}	SAR _{peak}
5000	72.9	20.7	285.6	68.1	19.2	260.3
5100	74.6	21.1	297.5	78.8	19.6	272.3
5200	76.5	21.6	310.3	71.8	20.1	284.7
5500	83.3	23.4	349.4	79.1	22.0	326.3
5800	78.0	21.9	340.9	74.1	200.5	324.7

Note: The reference SAR values were calculated using finite-difference time-domain FDTD method (feed-point impedance set to 50 Ω) and the mechanical dimensions of the D5GHzV2 dipole (manufactured by SPEAG). All SAR values normalized to 1 Watt forward power.

System Setup Block Diagram

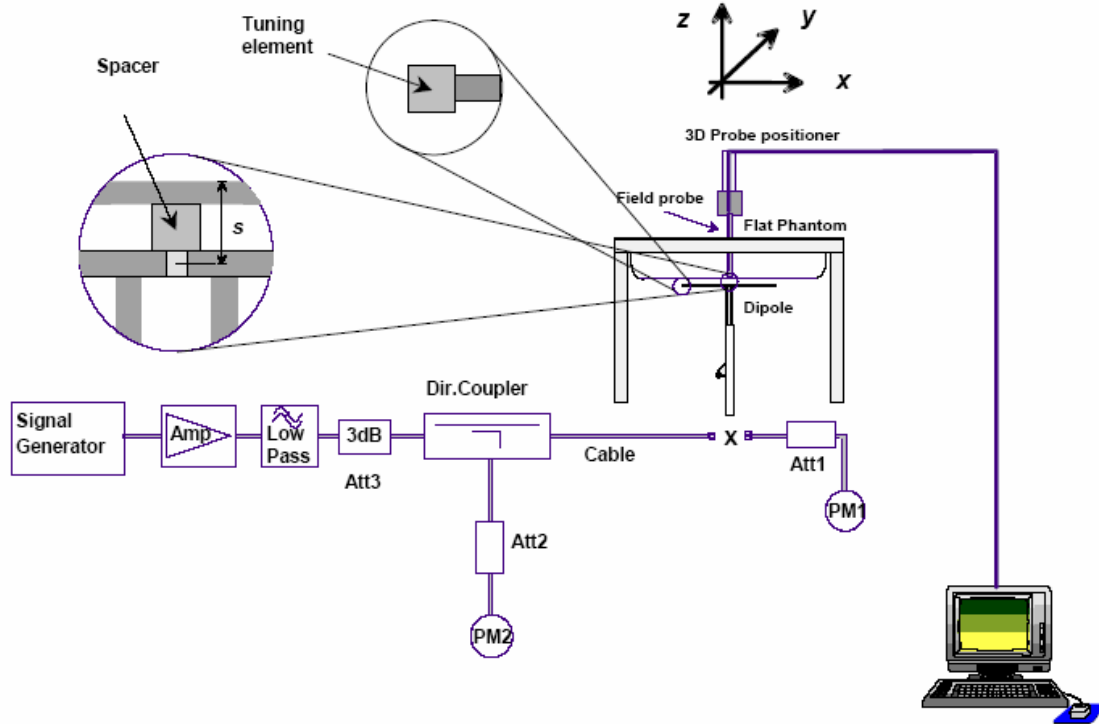

SAR MEASUREMENT RESULTS

This page summarizes the results of the performed dosimetric evaluation. The plots with the corresponding SAR distributions, which reveal information about the location of the maximum SAR with respect to the device, could be found in Appendix E.

SAR Body Worst-Case Test Data

Environmental Conditions

Temperature:	20° C - 22° C
Relative Humidity:	55% - 60° C
ATM Pressure:	1020mbar

Testing was performed by Jimmy Nguyen on 2008-05-20.

802.11b Mode (2.4GHz):

EUT Position	Test Mode	Frequency (MHz)	Conducted Power (mW)	Liquid	Phantom	Measured SAR (1g) Value (mW/g)	Limit (mW/g)	Plot #
Top side touching to the flat phantom	802.11b Low CH	2417	63.1	Body	Flat	0.026	1.6	1
Top side touching to the flat phantom	802.11b Mid CH	2437	79.43	Body	Flat	0.022	1.6	2
Top side touching to the flat phantom	802.11b High CH	2452	87.1	Body	Flat	0.033	1.6	3

802.11g Mode (2.4GHz):

EUT Position	Test Mode	Frequency (MHz)	Conducted Power (mW)	Liquid	Phantom	Measured SAR (1g) Value (mW/g)	Limit (mW/g)	Plot #
Top side touching to the flat phantom	802.11g Low CH	2417	56.2	Body	Flat	0.038	1.6	4
Top side touching to the flat phantom	802.11g Mid CH	2437	100	Body	Flat	0.065	1.6	5
Top side touching to the flat phantom	802.11g High CH	2452	55.0	Body	Flat	0.036	1.6	6

802.11a Mode (5GHz):

EUT Position	Test Mode	Frequency (MHz)	Conducted Power (mW)	Liquid	Phantom	Measured SAR (1g) Value (mW/g)	Limit (mW/g)	Plot #
Top side touching to the flat phantom	802.11a	5180	26.5	Body	Flat	0.151	1.6	7
Top side touching to the flat phantom	802.11a	5260	27.7	Body	Flat	0.096	1.6	8
Top side touching to the flat phantom	802.11a	5500	37.9	Body	Flat	0.202	1.6	9
Top side touching to the flat phantom	802.11a	5600	36.3	Body	Flat	0.214	1.6	10
Top side touching to the flat phantom	802.11a	5700	34.8	Body	Flat	0.117	1.6	11
Top side touching to the flat phantom	802.11a	5745	66.1	Body	Flat	0.060	1.6	12
Top side touching to the flat phantom	802.11a	5785	60.3	Body	Flat	0.055	1.6	13
Top side touching to the flat phantom	802.11a	5825	57.5	Body	Flat	0.047	1.6	14

PPENDIX A – MEASUREMENT UNCERTAINTY

The uncertainty budget has been determined for the DASY4 measurement system and is given in the following Table.

SASY4 Uncertainty Budget According to IEEE 1528								
Error Description	Uncertainty Value	Prob. Dist.	Div.	(c i) 1g	(c i) 10g	Std. Unc. (1g)	Std. Unc. (10g)	(v i) veff
Measurement System								
Probe Calibration	± 5.9%	N	1	1	1	± 5.9%	± 5.9%	∞
Axial Isotropy	± 4.7%	R	$\sqrt{3}$	0.7	0.7	± 1.9%	± 1.9%	∞
Hemispherical Isotropy	± 9.6%	R	$\sqrt{3}$	0.7	0.7	± 3.9%	± 3.9%	∞
Boundary Effects	± 1.0%	R	$\sqrt{3}$	1	1	± 0.6%	± 0.6%	∞
Linearity	± 4.7%	R	$\sqrt{3}$	1	1	± 2.7%	± 2.7%	∞
System Detection Limits	± 1.0%	R	$\sqrt{3}$	1	1	± 0.6%	± 0.6%	∞
Readout Electronics	± 0.3%	N	1	1	1	± 0.3%	± 0.3%	∞
Response Time	± 0.8%	R	$\sqrt{3}$	1	1	± 0.5%	± 0.5%	∞
Integration Time	± 2.6%	R	$\sqrt{3}$	1	1	± 1.5%	± 1.5%	∞
RF Ambient Conditions	± 3.0%	R	$\sqrt{3}$	1	1	± 1.7%	± 1.7%	∞
Probe Positioner	± 0.4%	R	$\sqrt{3}$	1	1	± 0.2%	± 0.2%	∞
Probe Positioning	± 2.9%	R	$\sqrt{3}$	1	1	± 1.7%	± 1.7%	∞
Max. SAR Eval.	± 1.0%	R	$\sqrt{3}$	1	1	± 0.6%	± 0.6%	∞
Test Sample Related								
Device Positioning	± 2.9%	N	1	1	1	± 2.9%	± 2.9%	145
Device Holder	± 3.6%	N	1	1	1	± 3.6%	± 2.6%	5
Power Drift	± 5.0%	R		1	1	± 2.9%	± 2.9%	∞
Phantom and Setup								
Phantom Uncertainty	± 4.0%	R	$\sqrt{3}$	1	1	± 2.3%	± 2.3%	∞
Liquid Conductivity (Target)	± 5.0%	R	$\sqrt{3}$	0.64	0.43	± 1.8%	± 1.2%	∞
Liquid Conductivity (meas.)	± 2.5%	N	1	0.64	0.43	± 1.6%	± 1.1%	∞
Liquid Permittivity (Target)	± 5.0%	R	$\sqrt{3}$	0.6	0.49	± 1.7%	± 1.4%	∞
Liquid Permittivity (meas.)	± 2.5%	N	1	0.6	0.49	± 1.5%	± 1%	∞
Combined Std. Uncertainty						± 10.8%	± 10.6%	330
Expanded STD Uncertainty						± 21.6%	± 21.1%	

SASY4 Uncertainty Budget According to CENELEC EN 50361								
Error Description	Uncertainty Value	Prob. Dist.	Div.	(c i) 1g	(c i) 10g	Std. Unc. (1g)	Std. Unc. (10g)	(v i) veff
Measurement System								
Probe Calibration	± 5.9%	N	1	1	1	± 5.9%	± 5.9%	∞
Axial Isotropy	± 4.7%	R	$\sqrt{3}$	0.7	0.7	± 1.9%	± 1.9%	∞
Spherical Isotropy	± 9.6%	R	$\sqrt{3}$	0.7	0.7	± 3.9%	± 3.9%	∞
Probe Linearity	± 4.7%	R	$\sqrt{3}$	1	1	± 2.7%	± 0.6%	∞
Detection Limits	± 1.0%	R	$\sqrt{3}$	1	1	± 0.6%	± 2.7%	∞
Boundary Effects	± 1.0%	R	$\sqrt{3}$	1	1	± 0.6%	± 0.6%	∞
Readout Electronics	± 0.3%	N	1	1	1	± 0.3%	± 0.3%	∞
Response Time	± 0.8%	N	1	1	1	± 0.8%	± 0.5%	∞
Noise	± 0.0%	N	1	1	1	± 0.0%	± 1.5%	∞
Integration Time	± 2.6%	N	1	1	1	± 2.6%	± 1.7%	∞
Mechanical Constraints								
Scanning System	± 0.4%	R	$\sqrt{3}$	1	1	± 0.2%	± 1.7%	∞
Phantom Shell	± 4.0%	R	$\sqrt{3}$	1	1	± 2.3%	± 0.6%	∞
Probe Positioning	± 2.9%	R	$\sqrt{3}$	1	1	± 1.7%	± 2.9%	∞
Device Positioning	± 2.9%	N	1	1	1	± 2.9%	± 2.6%	145
Physical Parameters0.5								
Liquid Conductivity (Target)	± 5.0%	R	$\sqrt{3}$	0.7	0.5	± 2.0%	± 1.2%	∞
Liquid Conductivity (meas.)	± 4.3%	R	$\sqrt{3}$	0.7	0.5	± 1.7%	± 1.1%	∞
Liquid Permittivity (Target)	± 5.0%	R	$\sqrt{3}$	0.6	0.5	± 1.7%	± 1.4%	∞
Liquid Permittivity (Target)	± 4.3%	R	$\sqrt{3}$	0.6	0.5	± 1.5%	± 1%	∞
Power Drift	± 5.0%	R	$\sqrt{3}$	1	1	± 2.9%	± 10.6%	∞
RF Ambient Conditions	± 3.0%	R	$\sqrt{3}$	1	1	± 1.7%	± 21.1%	∞
Post-Processing								
Extrap. and Integration	± 1.0%	R	$\sqrt{3}$	1	1	± 0.6%	± 2.3%	∞
Combined Std. Uncertainty						± 10.9%	± 10.6%	18125
Expanded Std. Uncertainty						± 21.7%	± 12.1%	

APPENDIX B – PROBE CALIBRATION CERTIFICATES

**Calibration Laboratory of
Schmid & Partner
Engineering AG**
Zeughausstrasse 43, 8004 Zurich, Switzerland



S Schweizerischer Kalibrierdienst
C Service suisse d'étalonnage
S Servizio svizzero di taratura
S Swiss Calibration Service

Accredited by the Swiss Federal Office of Metrology and Accreditation
The Swiss Accreditation Service is one of the signatories to the EA
Multilateral Agreement for the recognition of calibration certificates

Accreditation No.: **SCS 108**

Client **BACL**

Certificate No: **ET3-1604_Aug07**

CALIBRATION CERTIFICATE

Object **ET3DV6 - SN:1604**

Calibration procedure(s) **QA CAL-01.v6 and QA CAL-12.v5
Calibration procedure for dosimetric E-field probes**

Calibration date: **August 28, 2007**

Condition of the calibrated item **In Tolerance**

This calibration certificate documents the traceability to national standards, which realize the physical units of measurements (SI).
The measurements and the uncertainties with confidence probability are given on the following pages and are part of the certificate.

All calibrations have been conducted in the closed laboratory facility: environment temperature (22 ± 3)°C and humidity < 70%.

Calibration Equipment used (M&TE critical for calibration)

Primary Standards	ID #	Cal Date (Calibrated by, Certificate No.)	Scheduled Calibration
Power meter E4419B	GB41293874	29-Mar-07 (METAS, No. 217-00670)	Mar-08
Power sensor E4412A	MY41495277	29-Mar-07 (METAS, No. 217-00670)	Mar-08
Power sensor E4412A	MY41498087	29-Mar-07 (METAS, No. 217-00670)	Mar-08
Reference 3 dB Attenuator	SN: S5054 (3c)	8-Aug-07 (METAS, No. 217-00719)	Aug-08
Reference 20 dB Attenuator	SN: S5086 (20b)	29-Mar-07 (METAS, No. 217-00671)	Mar-08
Reference 30 dB Attenuator	SN: S5129 (30b)	8-Aug-07 (METAS, No. 217-00720)	Aug-08
Reference Probe ES3DV2	SN: 3013	4-Jan-07 (SPEAG, No. ES3-3013_Jan07)	Jan-08
DAE4	SN: 654	20-Apr-07 (SPEAG, No. DAE4-654_Apr07)	Apr-08
Secondary Standards	ID #	Check Date (in house)	Scheduled Check
RF generator HP 8648C	US3642U01700	4-Aug-99 (SPEAG, in house check Nov-05)	In house check: Nov-07
Network Analyzer HP 8753E	US37390585	18-Oct-01 (SPEAG, in house check Oct-06)	In house check: Oct-07

	Name	Function	Signature
Calibrated by:	Katja Pokovic	Technical Manager	
Approved by:	Niels Kuster	Quality Manager	

Issued: August 28, 2007

Certificate No: ET3-1604_Aug07

Page 1 of 9

Verify OK!
Wanda
9/17/2007

**Calibration Laboratory of
Schmid & Partner
Engineering AG**
Zeughausstrasse 43, 8004 Zurich, Switzerland



S Schweizerischer Kalibrierdienst
C Service suisse d'étalonnage
S Servizio svizzero di taratura
S Swiss Calibration Service

Accredited by the Swiss Federal Office of Metrology and Accreditation
The Swiss Accreditation Service is one of the signatories to the EA
Multilateral Agreement for the recognition of calibration certificates

Accreditation No.: **SCS 108**

Glossary:

TSL tissue simulating liquid
 NORM_{x,y,z} sensitivity in free space
 ConF sensitivity in TSL / NORM_{x,y,z}
 DCP diode compression point
 Polarization φ φ rotation around probe axis
 Polarization ϑ ϑ rotation around an axis that is in the plane normal to probe axis (at measurement center), i.e., ϑ = 0 is normal to probe axis

Calibration is Performed According to the Following Standards:

- a) IEEE Std 1528-2003, "IEEE Recommended Practice for Determining the Peak Spatial-Averaged Specific Absorption Rate (SAR) in the Human Head from Wireless Communications Devices: Measurement Techniques", December 2003
- b) IEC 62209-1, "Procedure to measure the Specific Absorption Rate (SAR) for hand-held devices used in close proximity to the ear (frequency range of 300 MHz to 3 GHz)", February 2005

Methods Applied and Interpretation of Parameters:

- **NORM_{x,y,z}:** Assessed for E-field polarization ϑ = 0 (f ≤ 900 MHz in TEM-cell; f > 1800 MHz: R22 waveguide). NORM_{x,y,z} are only intermediate values, i.e., the uncertainties of NORM_{x,y,z} does not effect the E²-field uncertainty inside TSL (see below *ConvF*).
- **NORM(f)_{x,y,z} = NORM_{x,y,z} * frequency_response** (see Frequency Response Chart). This linearization is implemented in DASY4 software versions later than 4.2. The uncertainty of the frequency response is included in the stated uncertainty of *ConvF*.
- **DCP_{x,y,z}:** DCP are numerical linearization parameters assessed based on the data of power sweep (no uncertainty required). DCP does not depend on frequency nor media.
- **ConvF and Boundary Effect Parameters:** Assessed in flat phantom using E-field (or Temperature Transfer Standard for f ≤ 800 MHz) and inside waveguide using analytical field distributions based on power measurements for f > 800 MHz. The same setups are used for assessment of the parameters applied for boundary compensation (alpha, depth) of which typical uncertainty values are given. These parameters are used in DASY4 software to improve probe accuracy close to the boundary. The sensitivity in TSL corresponds to NORM_{x,y,z} * *ConvF* whereby the uncertainty corresponds to that given for *ConvF*. A frequency dependent *ConvF* is used in DASY version 4.4 and higher which allows extending the validity from ± 50 MHz to ± 100 MHz.
- **Spherical isotropy (3D deviation from isotropy):** in a field of low gradients realized using a flat phantom exposed by a patch antenna.
- **Sensor Offset:** The sensor offset corresponds to the offset of virtual measurement center from the probe tip (on probe axis). No tolerance required.

ET3DV6 SN:1604

August 28, 2007

Probe ET3DV6

SN:1604

Manufactured:	July 30, 2001
Last calibrated:	May 2, 2006
Recalibrated:	August 28, 2007

Calibrated for DASYS Systems

(Note: non-compatible with DASYS2 system!)

ET3DV6 SN:1604

August 28, 2007

DASY - Parameters of Probe: ET3DV6 SN:1604

Sensitivity in Free Space ^A			Diode Compression ^B	
NormX	1.93 ± 10.1%	μV/(V/m) ²	DCP X	93 mV
NormY	1.80 ± 10.1%	μV/(V/m) ²	DCP Y	93 mV
NormZ	1.84 ± 10.1%	μV/(V/m) ²	DCP Z	93 mV

Sensitivity in Tissue Simulating Liquid (Conversion Factors)

Please see Page 8.

Boundary Effect

TSL	900 MHz	Typical SAR gradient: 5 % per mm	
	Sensor Center to Phantom Surface Distance	3.7 mm	4.7 mm
	SAR _{be} [%] Without Correction Algorithm	5.8	2.7
	SAR _{be} [%] With Correction Algorithm	0.1	0.1

TSL	1810 MHz	Typical SAR gradient: 10 % per mm	
	Sensor Center to Phantom Surface Distance	3.7 mm	4.7 mm
	SAR _{be} [%] Without Correction Algorithm	13.2	9.0
	SAR _{be} [%] With Correction Algorithm	1.0	0.0

Sensor Offset

Probe Tip to Sensor Center **2.7 mm**

The reported uncertainty of measurement is stated as the standard uncertainty of measurement multiplied by the coverage factor k=2, which for a normal distribution corresponds to a coverage probability of approximately 95%.

^A The uncertainties of NormX,Y,Z do not affect the E²-field uncertainty inside TSL (see Page 8).

^B Numerical linearization parameter: uncertainty not required.

ET3DV6 SN:1604

August 28, 2007

Frequency Response of E-Field

(TEM-Cell:ifi110 EXX, Waveguide: R22)

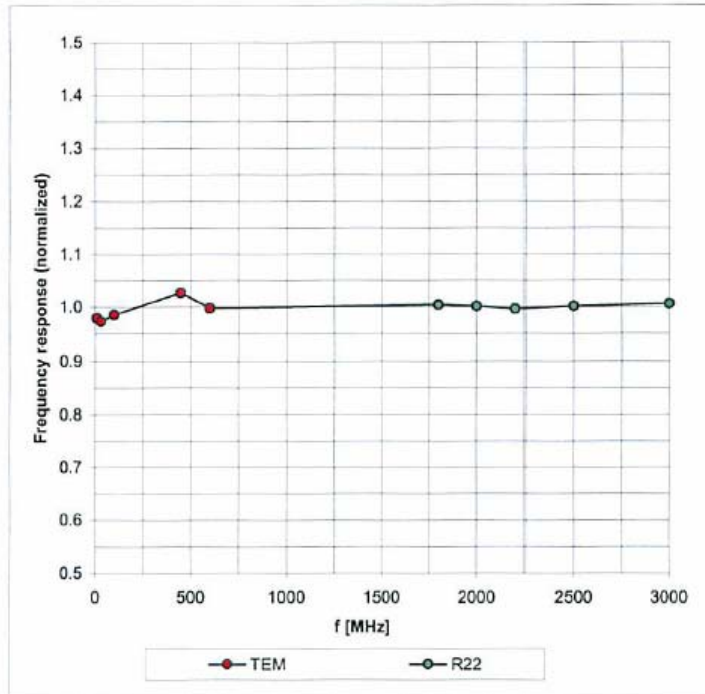

Uncertainty of Frequency Response of E-field: $\pm 6.3\%$ (k=2)

ET3DV6 SN:1604

August 28, 2007

Receiving Pattern (ϕ), $\theta = 0^\circ$

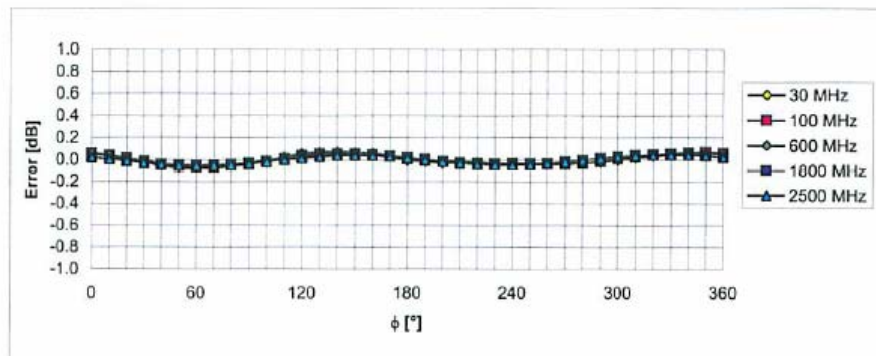
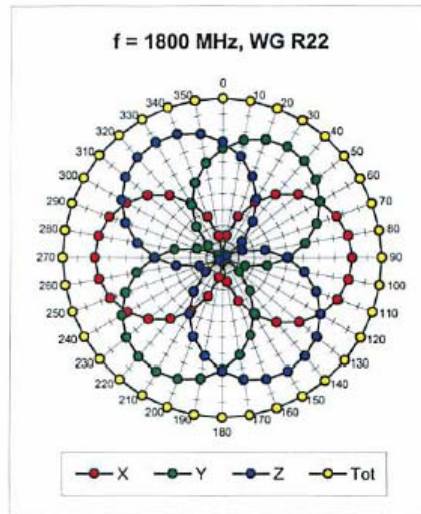
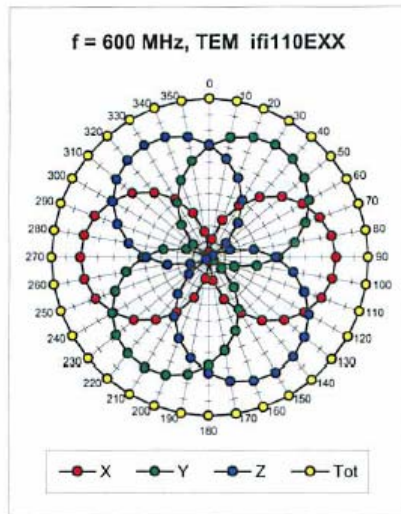

Uncertainty of Axial Isotropy Assessment: $\pm 0.5\%$ ($k=2$)

ET3DV6 SN:1604

August 28, 2007

Dynamic Range $f(SAR_{head})$ (Waveguide R22, $f = 1800$ MHz)

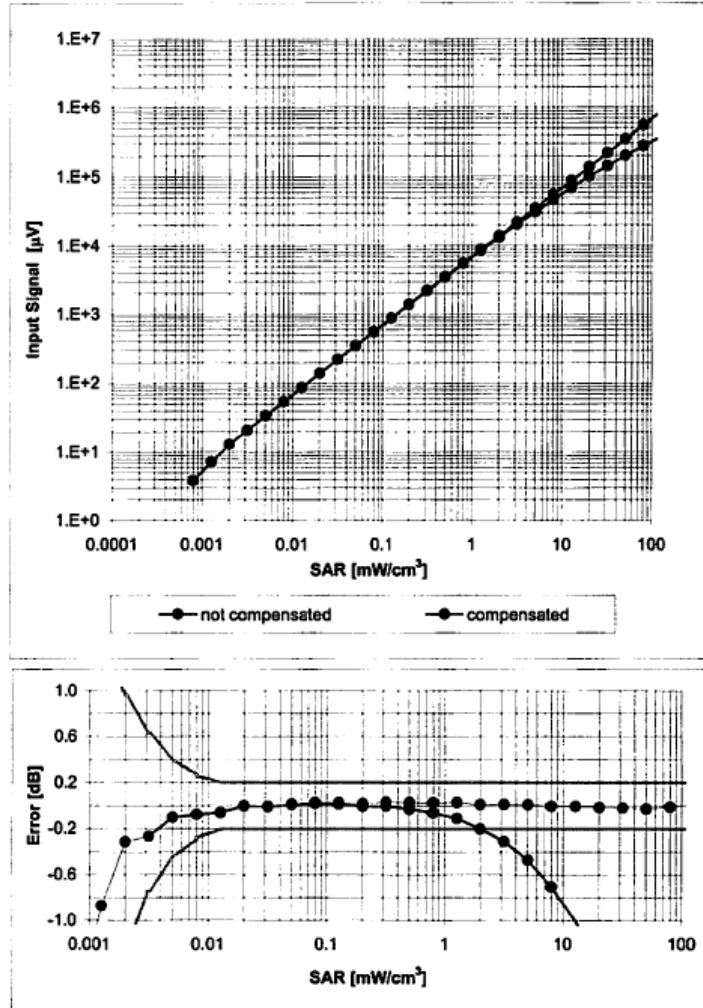

Uncertainty of Linearity Assessment: $\pm 0.6\%$ ($k=2$)

ET3DV6 SN:1604

August 28, 2007

Conversion Factor Assessment

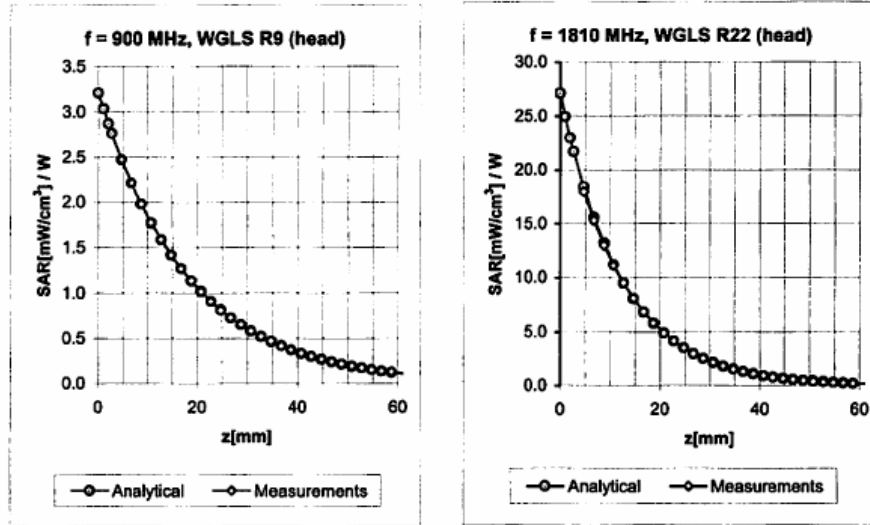

f [MHz]	Validity [MHz] ^c	TSL	Permittivity	Conductivity	Alpha	Depth	ConvF Uncertainty
450	± 50 / ± 100	Head	43.5 ± 5%	0.87 ± 5%	0.35	1.81	7.31 ± 13.3% (k=2)
835	± 50 / ± 99	Head	41.5 ± 5%	0.90 ± 5%	0.36	2.43	6.82 ± 11.0% (k=2)
900	± 50 / ± 100	Head	41.5 ± 5%	0.97 ± 5%	0.31	2.68	6.68 ± 11.0% (k=2)
1810	± 50 / ± 100	Head	40.0 ± 5%	1.40 ± 5%	0.52	2.55	5.29 ± 11.0% (k=2)
1900	± 50 / ± 101	Head	40.0 ± 5%	1.40 ± 5%	0.56	2.46	5.21 ± 11.0% (k=2)
2450	± 50 / ± 100	Head	39.2 ± 5%	1.80 ± 5%	0.68	1.87	4.74 ± 11.8% (k=2)
450	± 50 / ± 100	Body	56.7 ± 5%	0.94 ± 5%	0.30	1.88	7.84 ± 13.3% (k=2)
835	± 50 / ± 100	Body	55.2 ± 5%	0.97 ± 5%	0.28	2.82	6.47 ± 11.0% (k=2)
900	± 50 / ± 100	Body	55.0 ± 5%	1.05 ± 5%	0.42	2.35	6.23 ± 11.0% (k=2)
1810	± 50 / ± 100	Body	53.3 ± 5%	1.52 ± 5%	0.62	2.59	4.78 ± 11.0% (k=2)
1900	± 50 / ± 100	Body	53.3 ± 5%	1.52 ± 5%	0.74	2.24	4.68 ± 11.0% (k=2)
2450	± 50 / ± 100	Body	52.7 ± 5%	1.95 ± 5%	0.65	2.11	4.11 ± 11.8% (k=2)

^c The validity of ± 100 MHz only applies for DASYS v4.4 and higher (see Page 2). The uncertainty is the RSS of the ConvF uncertainty at calibration frequency and the uncertainty for the indicated frequency band.

ET3DV6 SN:1604

August 28, 2007

Deviation from Isotropy in HSL

Error (ϕ, θ), $f = 900$ MHz

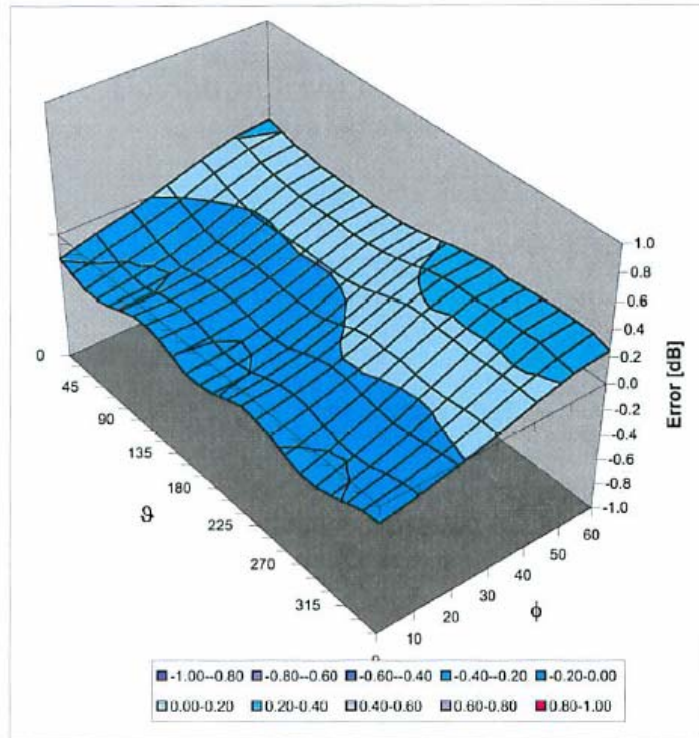

Uncertainty of Spherical Isotropy Assessment: $\pm 2.6\%$ ($k=2$)

This calibration certificate documents the traceability to national standards, which realize the physical units of measurements (SI).

**Calibration Laboratory of
Schmid & Partner
Engineering AG**
Zeughausstrasse 43, 8004 Zurich, Switzerland



S Schweizerischer Kalibrierdienst
C Service suisse d'étalonnage
S Servizio svizzero di taratura
S Swiss Calibration Service

Accredited by the Swiss Federal Office of Metrology and Accreditation
The Swiss Accreditation Service is one of the signatories to the EA
Multilateral Agreement for the recognition of calibration certificates

Accreditation No.: SCS 108

Client: **BACL**

Certificate No: **EX3-3619_Sep07**

CALIBRATION CERTIFICATE

Object: **EX3DV4 - SN:3619**

Calibration procedure(s): **QA CAL-01.v6 and QA CAL-14.v3
Calibration procedure for dosimetric E-field probes**

Calibration date: **September 10, 2007**

Condition of the calibrated item: **In Tolerance**

This calibration certificate documents the traceability to national standards, which realize the physical units of measurements (SI).
The measurements and the uncertainties with confidence probability are given on the following pages and are part of the certificate.

All calibrations have been conducted in the closed laboratory facility: environment temperature (22 ± 3)°C and humidity < 70%.

Calibration Equipment used (M&TE critical for calibration)

Primary Standards	ID #	Cal Date (Calibrated by, Certificate No.)	Scheduled Calibration
Power meter E4419B	GB41293874	29-Mar-07 (METAS, No. 217-00670)	Mar-08
Power sensor E4412A	MY41495277	29-Mar-07 (METAS, No. 217-00670)	Mar-08
Power sensor E4412A	MY41498087	29-Mar-07 (METAS, No. 217-00670)	Mar-08
Reference 3 dB Attenuator	SN: S5054 (3c)	8-Aug-07 (METAS, No. 217-00719)	Aug-08
Reference 20 dB Attenuator	SN: S5086 (20b)	29-Mar-07 (METAS, No. 217-00671)	Mar-08
Reference 30 dB Attenuator	SN: S5129 (30b)	8-Aug-07 (METAS, No. 217-00720)	Aug-08
Reference Probe ES3DV2	SN: 3013	4-Jan-07 (SPEAG, No. ES3-3013_Jan07)	Jan-08
DAE4	SN: 654	20-Apr-07 (SPEAG, No. DAE4-654_Apr07)	Apr-08
Secondary Standards	ID #	Check Date (in house)	Scheduled Check
RF generator HP 8648C	US3642U01700	4-Aug-99 (SPEAG, in house check Nov-05)	In house check: Nov-07
Network Analyzer HP 8753E	US37390585	18-Oct-01 (SPEAG, in house check Oct-06)	In house check: Oct-07

	Name	Function	Signature
Calibrated by:	Katja Pokovic	Technical Manager	
Approved by:	Niels Kuster	Quality Manager	

Issued: September 10, 2007

This calibration certificate shall not be reproduced except in full without written approval of the laboratory.

assessment of the parameters applied for boundary compensation (alpha, depth) of which typical uncertainty values are given. These parameters are used in DASY4 software to improve probe accuracy close to the boundary. The sensitivity in TSL corresponds to $NORM_{x,y,z} * ConvF$ whereby the uncertainty corresponds to that given for $ConvF$. A frequency dependent $ConvF$ is used in DASY version 4.4 and higher which allows extending the validity from ± 50 MHz to ± 100 MHz.

- *Spherical isotropy (3D deviation from isotropy):* in a field of low gradients realized using a

**Calibration Laboratory of
Schmid & Partner
Engineering AG**
Zeughausstrasse 43, 8004 Zurich, Switzerland



S Schweizerischer Kalibrierdienst
C Service suisse d'étalonnage
S Servizio svizzero di taratura
S Swiss Calibration Service

Accredited by the Swiss Federal Office of Metrology and Accreditation
The Swiss Accreditation Service is one of the signatories to the EA
Multilateral Agreement for the recognition of calibration certificates

Accreditation No.: **SCS 108**

Glossary:

TSL	tissue simulating liquid
$NORM_{x,y,z}$	sensitivity in free space
ConF	sensitivity in TSL / $NORM_{x,y,z}$
DCP	diode compression point
Polarization φ	φ rotation around probe axis
Polarization ϑ	ϑ rotation around an axis that is in the plane normal to probe axis (at measurement center), i.e., $\vartheta = 0$ is normal to probe axis

Calibration is Performed According to the Following Standards:

- IEEE Std 1528-2003, "IEEE Recommended Practice for Determining the Peak Spatial-Averaged Specific Absorption Rate (SAR) in the Human Head from Wireless Communications Devices: Measurement Techniques", December 2003
- IEC 62209-1, "Procedure to measure the Specific Absorption Rate (SAR) for hand-held devices used in close proximity to the ear (frequency range of 300 MHz to 3 GHz)", February 2005

Methods Applied and Interpretation of Parameters:

- $NORM_{x,y,z}$: Assessed for E-field polarization $\vartheta = 0$ ($f \leq 900$ MHz in TEM-cell; $f > 1800$ MHz: R22 waveguide). $NORM_{x,y,z}$ are only intermediate values, i.e., the uncertainties of $NORM_{x,y,z}$ does not effect the E^2 -field uncertainty inside TSL (see below $ConvF$).
- $NORM(f)_{x,y,z} = NORM_{x,y,z} * frequency_response$ (see Frequency Response Chart). This linearization is implemented in DASY4 software versions later than 4.2. The uncertainty of the frequency response is included in the stated uncertainty of $ConvF$.
- $DCP_{x,y,z}$: DCP are numerical linearization parameters assessed based on the data of power sweep (no uncertainty required). DCP does not depend on frequency nor media.
- $ConvF$ and Boundary Effect Parameters: Assessed in flat phantom using E-field (or Temperature Transfer Standard for $f \leq 800$ MHz) and inside waveguide using analytical field distributions based on power measurements for $f > 800$ MHz. The same setups are used for assessment of the parameters applied for boundary compensation (alpha, depth) of which typical uncertainty values are given. These parameters are used in DASY4 software to improve probe accuracy close to the boundary. The sensitivity in TSL corresponds to $NORM_{x,y,z} * ConvF$ whereby the uncertainty corresponds to that given for $ConvF$. A frequency dependent $ConvF$ is used in DASY version 4.4 and higher which allows extending the validity from ± 50 MHz to ± 100 MHz.
- Spherical isotropy (3D deviation from isotropy):* in a field of low gradients realized using a flat phantom exposed by a patch antenna.
- Sensor Offset:* The sensor offset corresponds to the offset of virtual measurement center from the probe tip (on probe axis). No tolerance required.

Calibrated for DASY Systems

EX3DV4 SN:3619

September 10, 2007

Probe EX3DV4

SN:3619

Manufactured: July 3, 2007
Calibrated: September 10, 2007

Calibrated for DASY Systems

(Note: non-compatible with DASY2 system!)

Certificate No: EX3-3619_Sep07

Page 3 of 9

EX3DV4 SN:3619

September 10, 2007

DASY - Parameters of Probe: EX3DV4 SN:3619

Sensitivity in Free Space^A

Diode Compression^B

NormX	0.460 ± 10.1%	$\mu V/(V/m)^2$	DCP X	88 mV
NormY	0.370 ± 10.1%	$\mu V/(V/m)^2$	DCP Y	87 mV
NormZ	0.400 ± 10.1%	$\mu V/(V/m)^2$	DCP Z	87 mV

Sensitivity in Tissue Simulating Liquid (Conversion Factors)

Please see Page 8.

Boundary Effect

TSL 5200 MHz Typical SAR gradient: 25 % per mm

Sensor Center to Phantom Surface Distance		2.0 mm	3.0 mm
SAR _{be} [%]	Without Correction Algorithm	8.0	3.0
SAR _{be} [%]	With Correction Algorithm	0.2	0.1

TSL 5800 MHz Typical SAR gradient: 30 % per mm

Sensor Center to Phantom Surface Distance		2.0 mm	3.0 mm
SAR _{be} [%]	Without Correction Algorithm	10.0	2.5
SAR _{be} [%]	With Correction Algorithm	0.2	0.1

Sensor Offset

Probe Tip to Sensor Center 1.0 mm

The reported uncertainty of measurement is stated as the standard uncertainty of measurement multiplied by the coverage factor k=2, which for a normal distribution corresponds to a coverage probability of approximately 95%.

^A The uncertainties of NormX,Y,Z do not affect the E²-field uncertainty inside TSL (see Page 8).

^B Numerical linearization parameter: uncertainty not required.

EX3DV4 SN:3619

September 10, 2007

Frequency Response of E-Field (TEM-Cell:ifi110 EXX, Waveguide: R22)

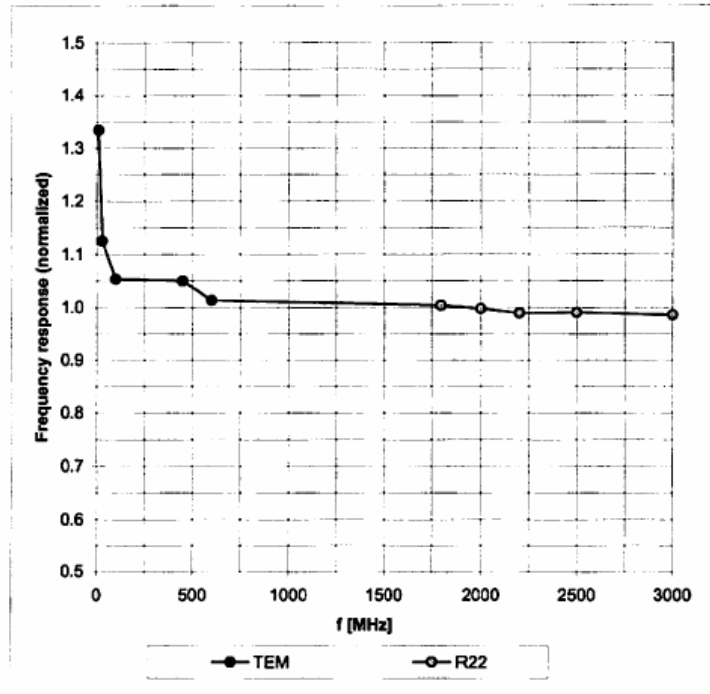

Uncertainty of Frequency Response of E-field: $\pm 6.3\%$ (k=2)

EX3DV4 SN:3619

September 10, 2007

Receiving Pattern (ϕ), $\vartheta = 0^\circ$

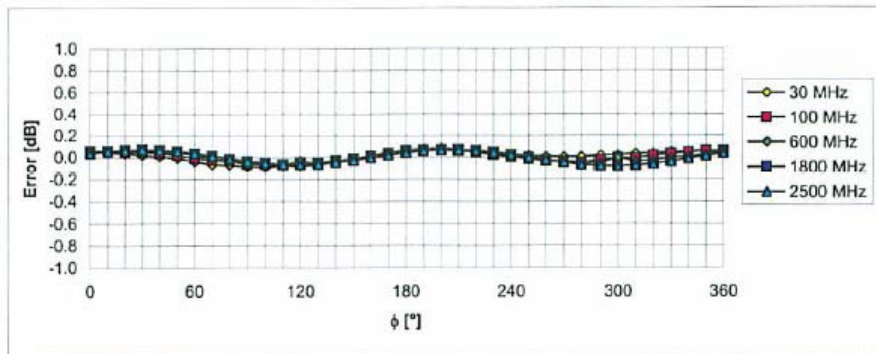
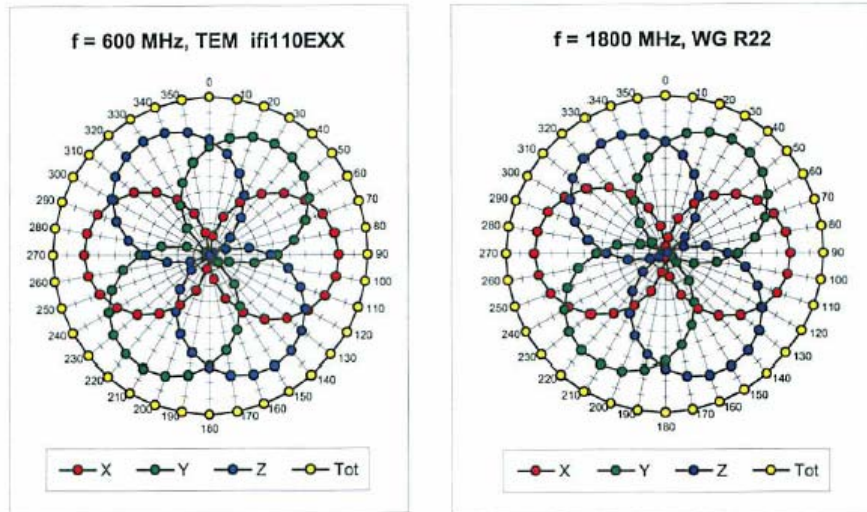

Uncertainty of Axial Isotropy Assessment: $\pm 0.5\%$ (k=2)

EX3DV4 SN:3619

September 10, 2007

Dynamic Range $f(SAR_{head})$ (Waveguide R22, $f = 1800$ MHz)

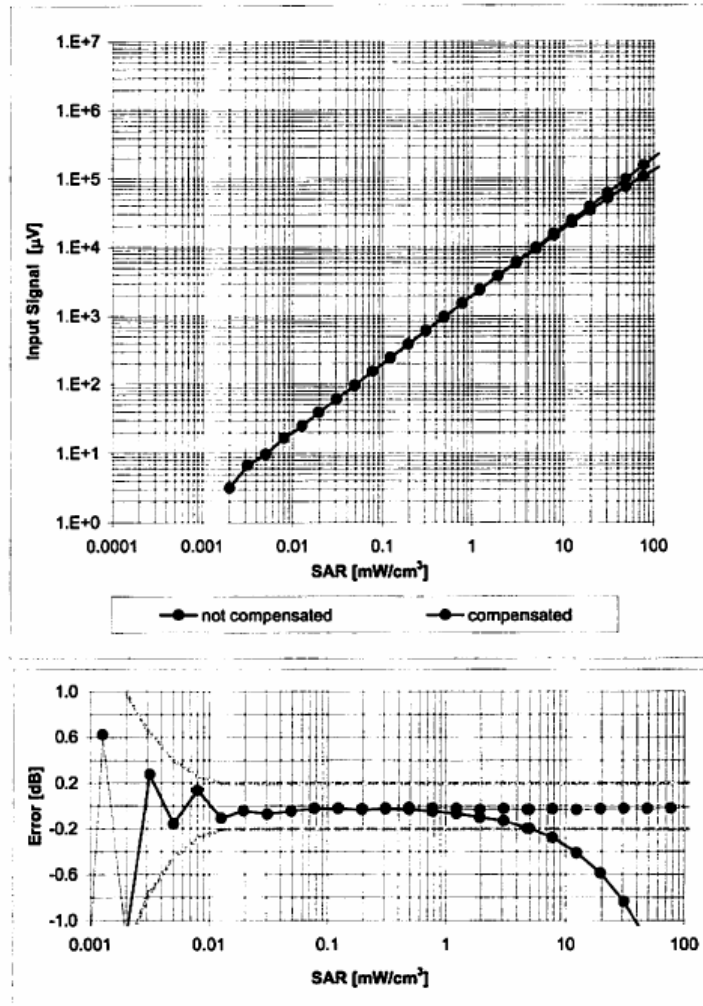

Uncertainty of Linearity Assessment: $\pm 0.6\%$ ($k=2$)

EX3DV4 SN:3619

September 10, 2007

Conversion Factor Assessment

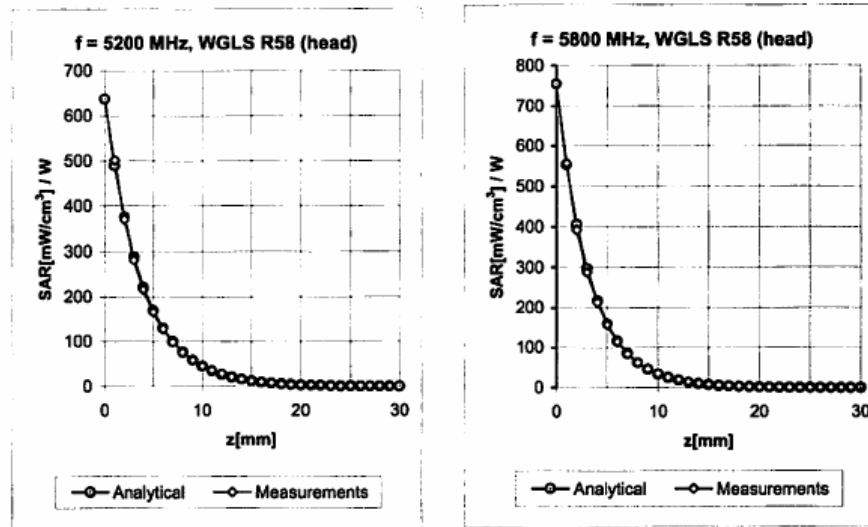

f [MHz]	Validity [MHz] ^c	TSL	Permittivity	Conductivity	Alpha	Depth	ConvF Uncertainty
5200	± 50 / ± 100	Head	36.0 ± 5%	4.66 ± 5%	0.38	1.60	4.64 ± 13.1% (k=2)
5500	± 50 / ± 100	Head	35.6 ± 5%	4.96 ± 5%	0.38	1.60	4.37 ± 13.1% (k=2)
5800	± 50 / ± 100	Head	35.3 ± 5%	5.27 ± 5%	0.38	1.60	4.07 ± 13.1% (k=2)
5200	± 50 / ± 100	Body	49.0 ± 5%	5.30 ± 5%	0.35	1.60	4.11 ± 13.1% (k=2)
5500	± 50 / ± 100	Body	48.6 ± 5%	5.65 ± 5%	0.34	1.60	3.80 ± 13.1% (k=2)
5800	± 50 / ± 100	Body	48.2 ± 5%	6.00 ± 5%	0.34	1.60	4.08 ± 13.1% (k=2)

^c The validity of ± 100 MHz only applies for DASY v4.4 and higher (see Page 2). The uncertainty is the RSS of the ConvF uncertainty at calibration frequency and the uncertainty for the indicated frequency band.

EX3DV4 SN:3619

September 10, 2007

Deviation from Isotropy in HSL

Error (ϕ, ϑ), $f = 900$ MHz

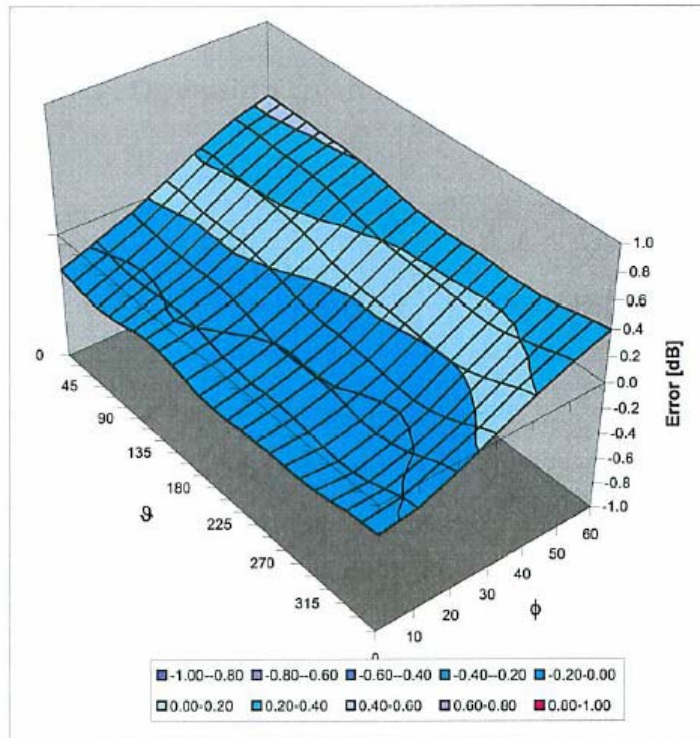

Uncertainty of Spherical Isotropy Assessment: $\pm 2.6\%$ ($k=2$)

APPENDIX C – DIPOLE CALIBRATION CERTIFICATES

**Calibration Laboratory of
Schmid & Partner
Engineering AG**
Zeughausstrasse 43, 8004 Zurich, Switzerland



S Schweizerischer Kalibrierdienst
C Service suisse d'étalonnage
S Servizio svizzero di taratura
S Swiss Calibration Service

Accredited by the Swiss Accreditation Service (SAS)
The Swiss Accreditation Service is one of the signatories to the EA
Multilateral Agreement for the recognition of calibration certificates

Accreditation No.: **SCS 108**

Client **BACL**

Certificate No: **D5100V2-1001_Nov07**

CALIBRATION CERTIFICATE

Object **D5GHzV2 - SN: 1001**

Calibration procedure(s) **QA CAL-22.v1
Calibration procedure for dipole validation kits between 3-6 GHz**

Calibration date: **November 8, 2007**

Condition of the calibrated item **In Tolerance**

This calibration certificate documents the traceability to national standards, which realize the physical units of measurements (SI).
The measurements and the uncertainties with confidence probability are given on the following pages and are part of the certificate.

All calibrations have been conducted in the closed laboratory facility: environment temperature (22 ± 3)°C and humidity < 70%.

Calibration Equipment used (M&TE critical for calibration)

Primary Standards	ID #	Cal Date (Calibrated by, Certificate No.)	Scheduled Calibration
Power meter EPM-442A	GB37480704	04-Oct-07 (METAS, No. 217-00736)	Oct-08
Power sensor HP 8481A	US37292783	04-Oct-07 (METAS, No. 217-00736)	Oct-08
Reference 20 dB Attenuator	SN: S5072.1 (20g)	07-Aug-07 (METAS, No. 217-00718)	Aug-08
Reference Probe EX3DV4	SN: 3503	9-Mar-07 (SPEAG, No. EX3-3503_Mar07)	Mar-08
DAE4	SN 601	30-Jan-07 (SPEAG, No. DAE4-601_Jan07)	Jan-08
Secondary Standards	ID #	Check Date (in house)	Scheduled Check
RF generator R&S SMT-06	100005	4-Aug-99 (SPEAG, in house check Oct-07)	In house check: Oct-09
Network Analyzer HP 8753E	US37390585 S4206	18-Oct-01 (SPEAG, in house check Oct-07)	In house check: Oct-08
Power meter E4419B	GB43310788	29-Oct-07 (SPEAG, in house check Oct-07)	In house check: Oct-08
Power sensor HP 8481A	MY41093315	29-Oct-07 (SPEAG, in house check Oct-07)	In house check: Oct-08

	Name	Function	Signature
Calibrated by:	Mike Meili	Laboratory Technician	
Approved by:	Katja Pokovic	Technical Manager	

Issued: November 14, 2007

This calibration certificate shall not be reproduced except in full without written approval of the laboratory.

**Calibration Laboratory of
Schmid & Partner
Engineering AG**
Zeughausstrasse 43, 8004 Zurich, Switzerland



S Schweizerischer Kalibrierdienst
C Service suisse d'étalonnage
S Servizio svizzero di taratura
S Swiss Calibration Service

Accredited by the Swiss Accreditation Service (SAS)
The Swiss Accreditation Service is one of the signatories to the EA
Multilateral Agreement for the recognition of calibration certificates

Accreditation No.: **SCS 108**

Glossary:

TSL tissue simulating liquid
ConvF sensitivity in TSL / NORM x,y,z
N/A not applicable or not measured

Calibration is Performed According to the Following Standards:

- a) IEC Std 62209 Part 2, "Evaluation of Human Exposure to Radio Frequency Fields from Handheld and Body-Mounted Wireless Communication Devices in the Frequency Range of 30 MHz to 6 GHz: Human models, Instrumentation, and Procedures"; Part 2: "Procedure to determine the Specific Absorption Rate (SAR) for including accessories and multiple transmitters", Draft Version 0.9, December 2004
- b) Federal Communications Commission Office of Engineering & Technology (FCC OET), "Evaluating Compliance with FCC Guidelines for Human Exposure to Radiofrequency Electromagnetic Fields; Additional Information for Evaluating Compliance of Mobile and Portable Devices with FCC Limits for Human Exposure to Radiofrequency Emissions", Supplement C (Edition 01-01) to Bulletin 65

Additional Documentation:

- c) DASY4 System Handbook

Methods Applied and Interpretation of Parameters:

- *Measurement Conditions:* Further details are available from the Validation Report at the end of the certificate. All figures stated in the certificate are valid at the frequency indicated.
- *Antenna Parameters with TSL:* The dipole is mounted with the spacer to position its feed point exactly below the center marking of the flat phantom section, with the arms oriented parallel to the body axis.
- *Feed Point Impedance and Return Loss:* These parameters are measured with the dipole positioned under the liquid filled phantom. The impedance stated is transformed from the measurement at the SMA connector to the feed point. The Return Loss ensures low reflected power. No uncertainty required.
- *Electrical Delay:* One-way delay between the SMA connector and the antenna feed point. No uncertainty required.
- *SAR measured:* SAR measured at the stated antenna input power.
- *SAR normalized:* SAR as measured, normalized to an input power of 1 W at the antenna connector.
- *SAR for nominal TSL parameters:* The measured TSL parameters are used to calculate the nominal SAR result.

Measurement Conditions

DASY system configuration, as far as not given on page 1.

DASY Version	DASY4	V4.7
Extrapolation	Advanced Extrapolation	
Phantom	Modular Flat Phantom V5.0	
Distance Dipole Center - TSL	10 mm	with Spacer
Area Scan resolution	dx, dy = 10 mm	
Zoom Scan Resolution	dx, dy = 4.0 mm, dz = 2.5 mm	
Frequency	5200 MHz ± 1 MHz 5800 MHz ± 1 MHz	

Head TSL parameters at 5200 MHz

The following parameters and calculations were applied.

	Temperature	Permittivity	Conductivity
Nominal Head TSL parameters	22.0 °C	36.0	4.66 mho/m
Measured Head TSL parameters	(22.0 ± 0.2) °C	35.0 ± 6 %	4.46 mho/m ± 6 %
Head TSL temperature during test	(22.0 ± 0.2) °C	—	—

SAR result with Head TSL at 5200 MHz

SAR averaged over 1 cm³ (1 g) of Head TSL	condition	
SAR measured	100 mW input power	7.68 mW / g
SAR normalized	normalized to 1W	76.8 mW / g
SAR for nominal Head TSL parameters ¹	normalized to 1W	76.2 mW / g ± 19.9 % (k=2)

SAR averaged over 10 cm³ (10 g) of Head TSL	condition	
SAR measured	100 mW input power	2.17 mW / g
SAR normalized	normalized to 1W	21.7 mW / g
SAR for nominal Head TSL parameters ¹	normalized to 1W	21.5 mW / g ± 19.5 % (k=2)

¹ Correction to nominal TSL parameters according to c), chapter "SAR Sensitivities"

Head TSL parameters at 5800 MHz

The following parameters and calculations were applied.

	Temperature	Permittivity	Conductivity
Nominal Head TSL parameters	22.0 °C	35.3	5.27 mho/m
Measured Head TSL parameters	(22.0 ± 0.2) °C	33.9 ± 6 %	5.01 mho/m ± 6 %
Head TSL temperature during test	(21.4 ± 0.2) °C	—	—

SAR result with Head TSL at 5800 MHz

SAR averaged over 1 cm ³ (1 g) of Head TSL	condition	
SAR measured	100 mW input power	8.29 mW / g
SAR normalized	normalized to 1W	82.9 mW / g
SAR for nominal Head TSL parameters ²	normalized to 1W	81.7 mW / g ± 19.9 % (k=2)

SAR averaged over 10 cm ³ (10 g) of Head TSL	condition	
SAR measured	100 mW input power	2.34 mW / g
SAR normalized	normalized to 1W	23.4 mW / g
SAR for nominal Head TSL parameters ²	normalized to 1W	23.0 mW / g ± 19.5 % (k=2)

² Correction to nominal TSL parameters according to c), chapter "SAR Sensitivities"

Appendix

Antenna Parameters with Head TSL at 5200 MHz

Impedance, transformed to feed point	50.2 Ω - 10.0 jΩ
Return Loss	-20.0 dB

Antenna Parameters with Head TSL at 5800 MHz

Impedance, transformed to feed point	54.5 Ω - 0.9 jΩ
Return Loss	-27.1 dB

General Antenna Parameters and Design

Electrical Delay (one direction)	1.202 ns
----------------------------------	----------

After long term use with 40 W radiated power, only a slight warming of the dipole near the feedpoint can be measured.

The dipole is made of standard semirigid coaxial cable. The center conductor of the feeding line is directly connected to the second arm of the dipole. The antenna is therefore short-circuited for DC-signals. No excessive force must be applied to the dipole arms, because they might bend or the soldered connections near the feedpoint may be damaged.

Additional EUT Data

Manufactured by	SPEAG
Manufactured on	April 2, 2003

DASY4 Validation Report for Head TSL

Date/Time: 08.11.2007 14:03:06

Test Laboratory: SPEAG, Zurich, Switzerland

DUT: Dipole 5GHz; Type: D5GHz; Serial: D5100V2 - SN:1001

Communication System: CW-5GHz; Frequency: 5200 MHz; Frequency: 5800 MHz; Duty Cycle: 1:1

Medium parameters used: $f = 5200$ MHz; $\sigma = 4.46$ mho/m; $\epsilon_r = 35$; $\rho = 1000$ kg/m³

Medium parameters used: $f = 5800$ MHz; $\sigma = 5.03$ mho/m; $\epsilon_r = 33.9$; $\rho = 1000$ kg/m³

Phantom section: Flat Section

Measurement Standard: DASY4 (High Precision Assessment)

DASY4 Configuration:

- Probe: EX3DV4 - SN3503; ConvF(5.56, 5.56, 5.56)ConvF(4.97, 4.97, 4.97); Calibrated: 09.03.2007
- Sensor-Surface: 2mm (Mechanical Surface Detection)
- Electronics: DAE4 Sn601; Calibrated: 30.01.2007
- Phantom: Flat Phantom 5.0 (front); Type: QD000P50AA; Serial: 1001
- Measurement SW: DASY4, V4.7 Build 55; Postprocessing SW: SEMCAD, V1.8 Build 176

d=10mm, Pin=100mW, f=5200 MHz/Area Scan (91x91x1):

Measurement grid: dx=10mm, dy=10mm

Maximum value of SAR (interpolated) = 16.3 mW/g

d=10mm, Pin=100mW, f=5200 MHz/Zoom Scan (8x8x8), dist=2mm (8x8x8)/Cube 0:

Measurement grid: dx=4mm, dy=4mm, dz=2.5mm

Reference Value = 50.6 V/m; Power Drift = 0.006 dB

Peak SAR (extrapolated) = 28.9 W/kg

SAR(1 g) = 7.68 mW/g; SAR(10 g) = 2.17 mW/g

Maximum value of SAR (measured) = 14.6 mW/g

d=10mm, Pin=100mW, f=5800 MHz/Zoom Scan (8x8x10), dist=2mm (8x8x10)/Cube 0:

Measurement grid: dx=4mm, dy=4mm, dz=2.5mm

Reference Value = 48.8 V/m; Power Drift = 0.004 dB

Peak SAR (extrapolated) = 33.6 W/kg

SAR(1 g) = 8.29 mW/g; SAR(10 g) = 2.34 mW/g

Maximum value of SAR (measured) = 17.3 mW/g

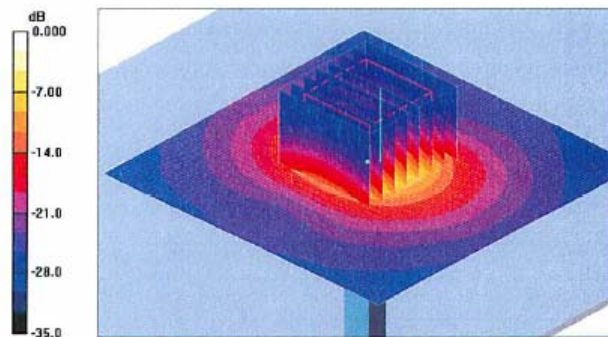

Impedance Measurement Plot for Head TSL

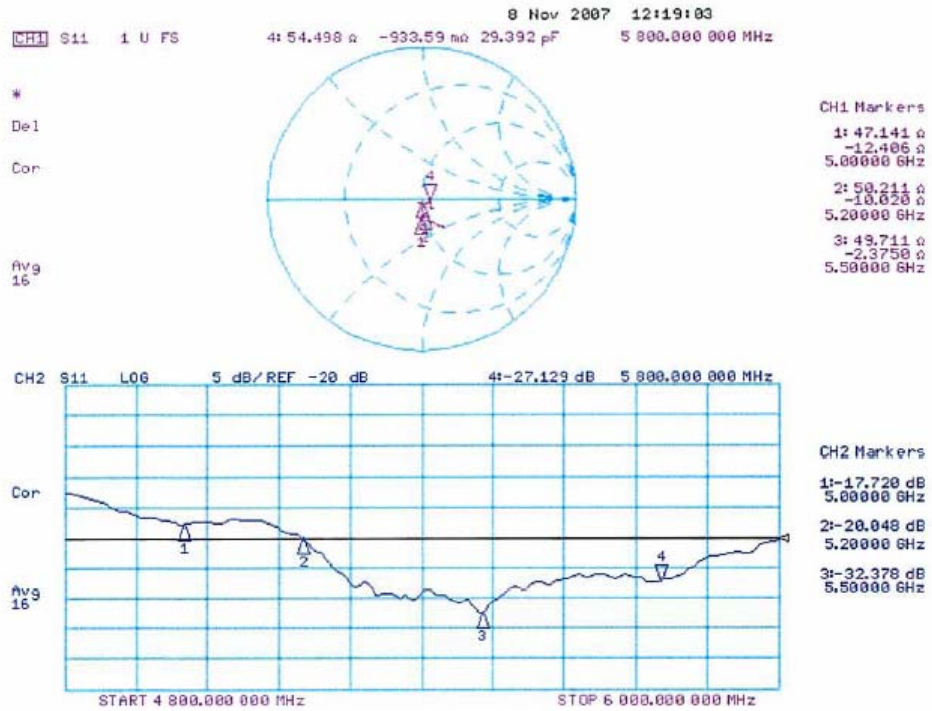



NCL CALIBRATION LABORATORIES

Calibration File No: DC-713
Project Number: BACL-CAL-D-2450-5249

CERTIFICATE OF CALIBRATION

It is certified that the equipment identified below has been calibrated in the **NCL CALIBRATION LABORATORIES** by qualified personnel following recognized procedures and using transfer standards traceable to NRC/NIST.

BACL Validation Dipole

Manufacturer: APREL Laboratories

Part number: D-2450-S-1

Frequency: 2450 MHz

Serial No: BCL-141

Customer: Bay Area Compliance Laboratory

Calibrated: 28th August 2006
Released on: 28th August 2006

Released By: _____

NCL CALIBRATION LABORATORIES

51 SPECTRUM WAY
NEPEAN, ONTARIO
CANADA K2R 1E6

Division of APREL Lab.
TEL: (613) 820-4988
FAX: (613) 820-4162

verified
[Signature]
2006-8-31

- Feed Point Impedance and Return Loss: These parameters are measured with the dipole positioned under the liquid filled phantom. The impedance stated is transformed from the measurement at the SMA connector to the feed point. The Return Loss ensures low reflected power. NO UNCERTAINTY REQUIRED.
- Electrical Delay: One-way delay between the SMA connector and the antenna feed point. No uncertainty required.
- SAR measured: SAR measured at the stated antenna input power.
- SAR normalized: SAR as measured, normalized to an input power of 1 W at the antenna connector.
- SAR for nominal TSL parameters: The measured TSL parameters are used to calculate the nominal SAR result.

NCL Calibration Laboratories

Division of APREL Laboratories.

Conditions

Dipole BCL-141 was received from customer in good condition for re-calibration, SMA connector required cleaning prior to calibration.

Ambient Temperature of the Laboratory: 22 °C +/- 0.5°C

Temperature of the Tissue: 21 °C +/- 0.5°C

We the undersigned attest that to the best of our knowledge the calibration of this device has been accurately conducted and that all information contained within this report has been reviewed for accuracy.

D. Brooks
Member of Engineering Staff
(Calibration Engineer)

This page has been reviewed for content and attested to by signature within this document.

NCL Calibration Laboratories

Division of APREL Laboratories.

Calibration Results Summary

The following results relate the Calibrated Dipole and should be used as a quick reference for the user.

Mechanical Dimensions

Length: 51.5 mm
Height: 30.4 mm

Electrical Specification

SWR: 1.095 U to 1.397 U
Return Loss: -26.77 dB to -15.52 dB
Impedance: 47.81 Ω to 63.37 Ω

System Validation Results

Frequency	1 Gram	10 Gram	Peak
2450 MHz	5.31	2.44	10.18

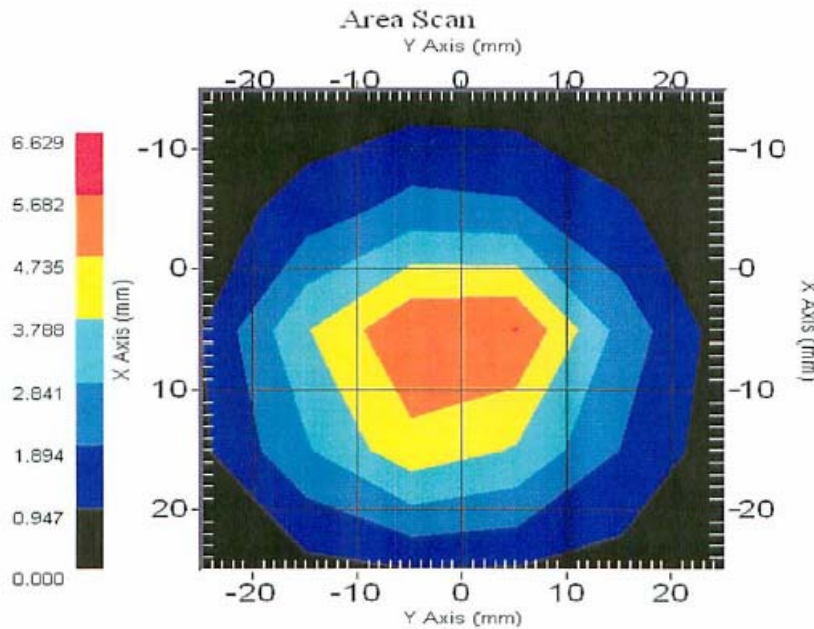

This page has been reviewed for content and attested to by signature within this document.

NCL Calibration Laboratories

Division of APREL Laboratories.

Introduction

This Calibration Report has been produced in line with the SSI Dipole Calibration Procedure SSI-TP-018-ALSAS. The results contained within this report are for Validation Dipole BCL-141. The calibration routine consisted of a three-step process. Step 1 was a mechanical verification of the dipole to ensure that it meets the mechanical specifications. Step 2 was an Electrical Calibration for the Validation Dipole, where the SWR, Impedance, and the Return loss were assessed. Step 3 involved a System Validation using the ALSAS-10U, along with APREL E-020 130 MHz to 26 GHz E-Field Probe Serial Number 212.

References

SSI-TP-018-ALSAS Dipole Calibration Procedure
SSI-TP-016 Tissue Calibration Procedure
IEEE 1528 "Recommended Practice for Determining the Peak Spatial-Average Specific Absorption Rate (SAR) in the Human Body Due to Wireless Communications Devices: Experimental Techniques"

Conditions

Dipole BCL-141 was received from customer in good condition for re-calibration, SMA connector required cleaning prior to calibration.

Ambient Temperature of the Laboratory: 22 °C +/- 0.5°C
Temperature of the Tissue: 20 °C +/- 0.5°C

This page has been reviewed for content and attested to by signature within this document.

NCL Calibration Laboratories

Division of APREL Laboratories.

Dipole Calibration Results

Mechanical Verification

APREL Length	APREL Height	Measured Length	Measured Height
51.5 mm	30.4 mm	51.6 mm	30.5 mm

Tissue Validation

Head Tissue 2450 MHz	Measured
Dielectric constant, ϵ_r	39.2
Conductivity, σ [S/m]	1.80

This page has been reviewed for content and attested to by signature within this document.

NCL Calibration Laboratories

Division of APREL Laboratories.

Electrical Calibration

Test	Result
S11 R/L	-26.77 dB to -15.52 dB
SWR	1.095 U to 1.397 U
Impedance	47.81 Ω to 63.37 Ω

The Following Graphs are the results as displayed on the Vector Network Analyzer.

S11 Parameter Return Loss

S22 REVERSE REFLECTION



CH 4 - S22
REFERENCE PLANE
0.0000 mm

MARKER 1
2.450046 GHz
-15.516 dB

MARKER TO MAX
▶ MARKER TO MIN

2 2.352262 GHz
-26.773 dB

MARKER READOUT
FUNCTIONS

This page has been reviewed for content and attested to by signature within this document.

NCL Calibration Laboratories
Division of APREL Laboratories.

SWR

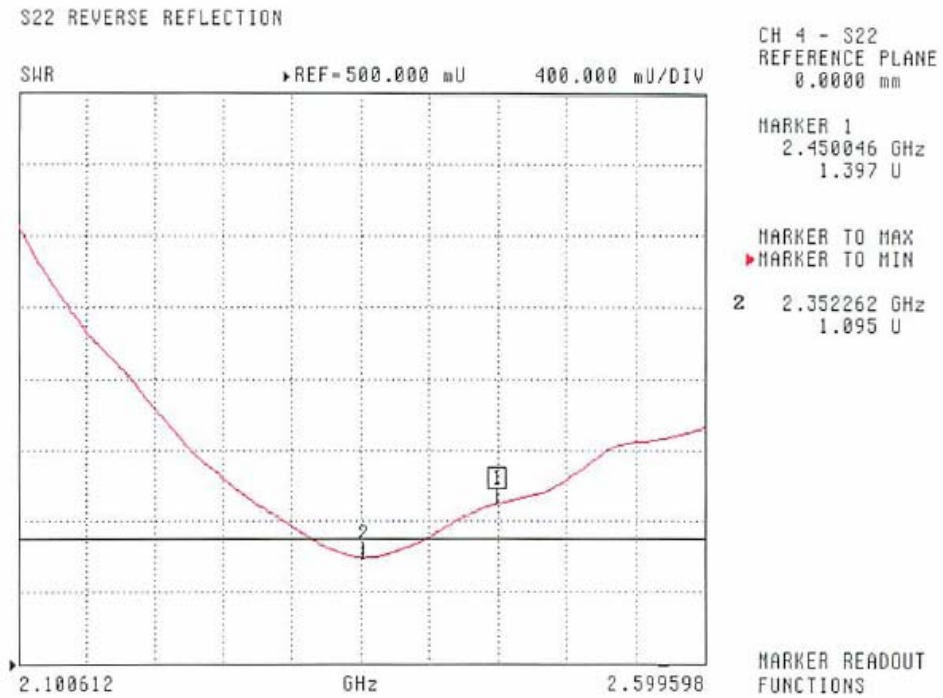

This page has been reviewed for content and attested to by signature within this document.

NCL Calibration Laboratories

Division of APREL Laboratories.

Smith Chart Dipole Impedance

S22 REVERSE REFLECTION
IMPEDANCE

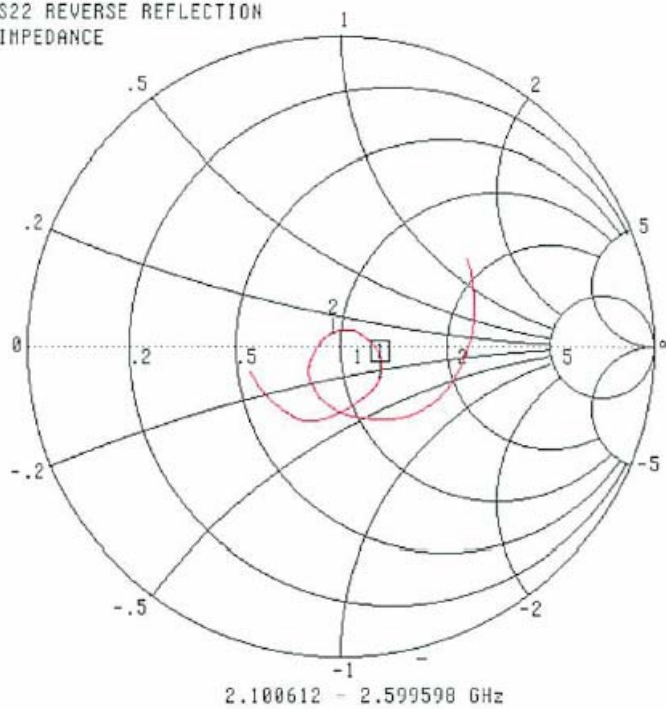

CH 4 - S22
REFERENCE PLANE
0.0000 mm

MARKER 1
2.450046 GHz
63.373 Ω
-13.350 j Ω

MARKER TO MAX
▶ MARKER TO MIN
2 2.352262 GHz
47.800 Ω
3.861 j Ω

MARKER READOUT
FUNCTIONS

This page has been reviewed for content and attested to by signature within this document. 8

NCL Calibration Laboratories

Division of APREL Laboratories.

System Validation Results Using the Electrically Calibrated Dipole

Head Tissue Frequency	1 Gram	10 Gram	Peak Above Feed Point
2450 MHz	5.31	2.44	10.18

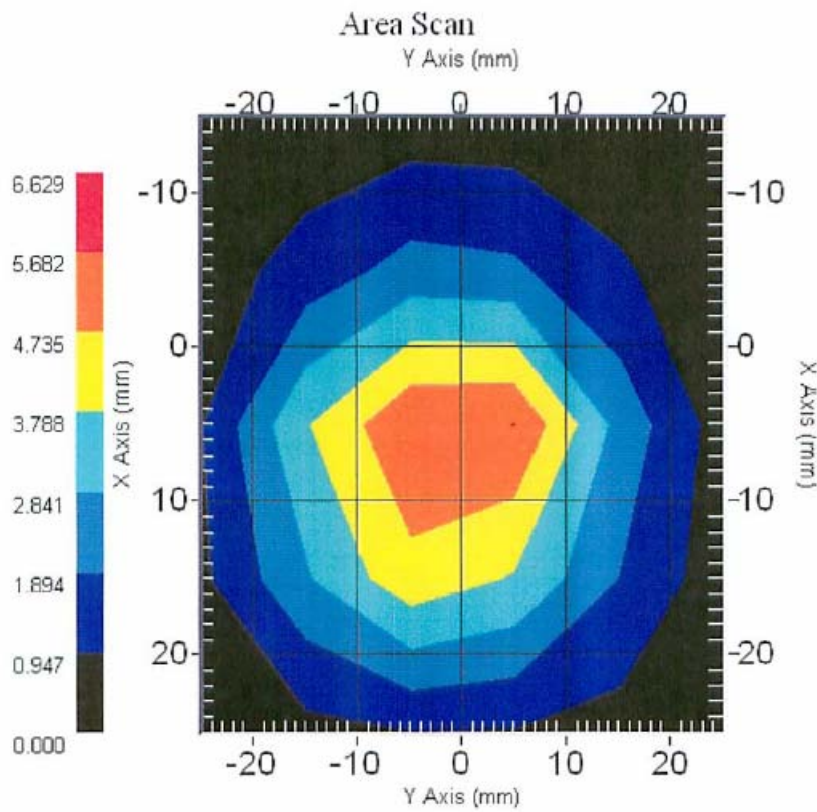

This page has been reviewed for content and attested to by signature within this document.

NCL Calibration Laboratories

Division of APREL Laboratories.

Test Equipment

The test equipment used during Probe Calibration, manufacturer, model number and, current calibration status are listed and located on the main APREL server R:\NCL\Calibration Equipment\Instrument List

This page has been reviewed for content and attested to by signature within this document.

10

APPENDIX D - TEST SYSTEM VERIFICATIONS SCANS

Liquid Measurement Result

Testing was performed by Jimmy Nguyen on 2008-05-20.

Simulant	Freq [MHz]	Parameters	Liquid Temp [°C]	Target Value	Measured Value	Deviation [%]	Limits [%]
Head	2450	ϵ_r	22	39.2	39.3	0.26	±5
		σ	22	1.80	1.88	4.44	±5
		1g SAR	22	52.4	55.6	6.11	±10

Simulant	Freq [MHz]	Parameters	Liquid Temp [°C]	Target Value	Measured Value	Deviation [%]	Limits [%]
Head	5200	ϵ_r	22	36.0	37.2	3.33	±5
		σ	22	4.66	4.76	2.15	±5
		1g SAR	22	76.5	80.8	5.62	±10
	5500	ϵ_r	22	35.6	36.9	3.65	±5
		σ	22	4.96	4.83	-2.62	±5
		1g SAR	22	83.3	79.6	-4.44	±10
	5800	ϵ_r	22	35.3	36.3	2.83	±5
		σ	22	5.27	5.03	-4.55	±5
		1g SAR	22	78.0	82.6	5.90	±10

Test Laboratory: Bay Area Compliance Lab Corp. (BACL)

System Performance Check 2450MHz Head

Dipole 2450 MHz; Type: D2450V2; Serial: D2450V2 - SN: BCL-141

Communication System: CW; Frequency: 2450 MHz; Duty Cycle: 1:1

Medium parameters used: $f = 2450$ MHz; $\sigma = 1.88$ mho/m; $\epsilon_r = 39.3$; $\rho = 1000$ kg/m³

Phantom section: Flat Section

DASY4 Configuration:

- Probe: ET3DV6 - SN1604; ConvF(4.74, 4.74, 4.74); Calibrated: 8/28/2007
- Sensor-Surface: 4mm (Mechanical Surface Detection)
- Electronics: DAE3 Sn456; Calibrated: 11/8/2007
- Phantom: SAM with CRP; Type: Twin SAM; Serial: TP-1032
- Measurement SW: DASY4, V4.7 Build 71; Post processing SW: SEMCAD, V1.8 Build 184

d =10 mm, Pin = 0.5W/Area Scan (61x101x1): Measurement grid: dx=15mm, dy=15mm

Maximum value of SAR (interpolated) = 47.6 mW/g

d =10 mm, Pin = 0.5W/Zoom Scan (7x7x7)/Cube 0: Measurement grid: dx=5mm, dy=5mm, dz=5mm

Reference Value = 151.6 V/m; Power Drift = 0.055 dB

Peak SAR (extrapolated) = 97.9 W/kg

SAR (1 g) = 27.8 mW/g; SAR (10 g) = 12.1 mW/g

Maximum value of SAR (measured) = 39.8 mW/g

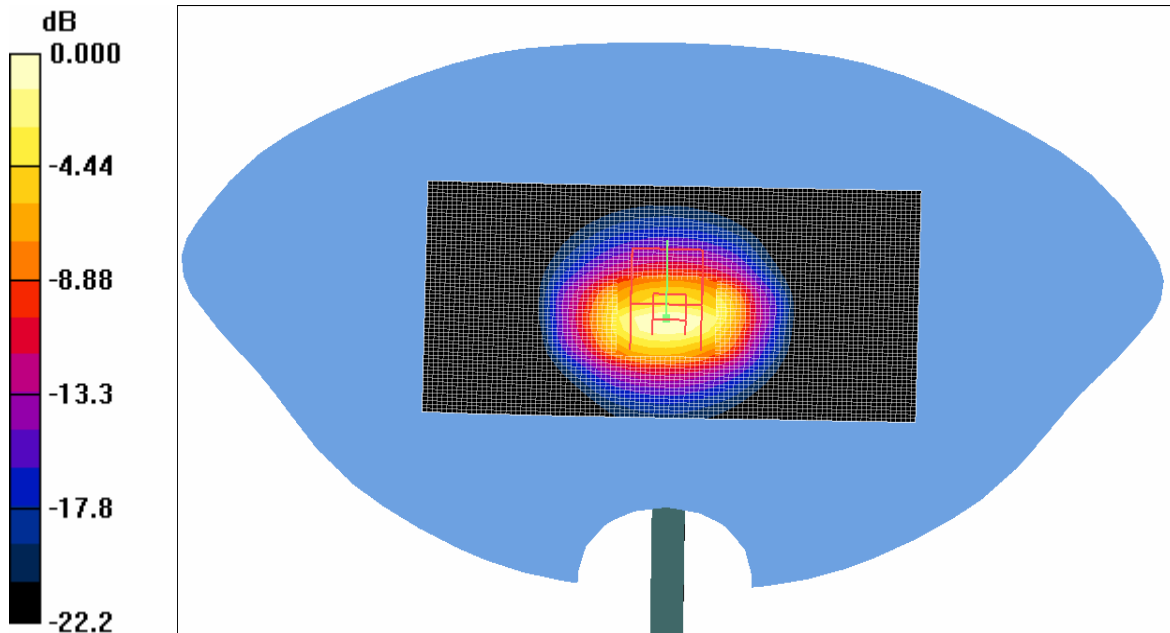

0 dB = 39.8 mW/g

System Validation for Head Tissue

Test Laboratory: Bay Area Compliance Lab Corp. (BACL)

5200 MHz System Validation for Head

Dipole 5100MHZ; Type: D5100; Serial: D5100V2-SN: 1001

Communication System: CW; Frequency: 5200 MHz; Duty Cycle: 1:1

Medium parameters used: $f = 5200$ MHz; $\sigma = 4.76$ mho/m; $\epsilon_r = 37.2$; $\rho = 1000$ kg/m³

Phantom section: Flat Section

DASY4 Configuration:

- Probe: EX3DV4 - SN3619; ConvF(4.64, 4.64, 4.64); Calibrated: 9/10/2007
- Sensor-Surface: 2mm (Mechanical Surface Detection)
- Electronics: DAE3 Sn456; Calibrated: 11/8/2007
- Phantom: SAM with CRP; Type: SAM; Serial: TP-1032
- Measurement SW: DASY4, V4.6 Build 23; Post processing SW: SEMCAD, V1.8 Build 184

d=10mm, Pin=0.5W/Area Scan (61x61x1): Measurement grid: dx=5mm, dy=5mm

Maximum value of SAR (interpolated) = 89.8 mW/g

d=10mm, Pin=0.5W/Zoom Scan (11x11x9)/Cube 0: Measurement grid: dx=3mm, dy=3mm, dz=2.5mm

Reference Value = 99.2 V/m; Power Drift = 0.106 dB

Peak SAR (extrapolated) = 168.9 W/kg

SAR (1 g) = 40.4 mW/g; SAR (10 g) = 11.6 mW/g

Maximum value of SAR (measured) = 84.9 mW/g

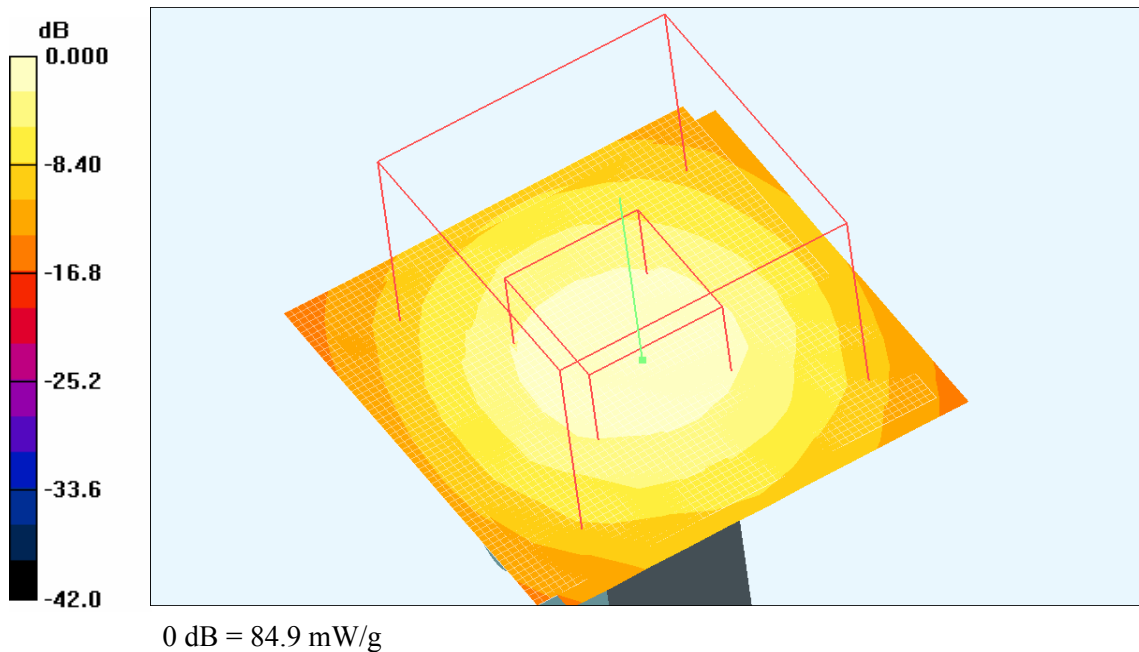

Test Laboratory: Bay Area Compliance Lab Corp. (BACL)

5500 MHz System Validation for Head

Dipole 5100MHZ; Type: D5100; Serial: D5100V2-SN: 1001

Communication System: CW; Frequency: 5500 MHz; Duty Cycle: 1:1

Medium parameters used: $f = 5500$ MHz; $\sigma = 4.83$ mho/m; $\epsilon_r = 36.9$; $\rho = 1000$ kg/m³

Phantom section: Flat Section

DASY4 Configuration:

- Probe: EX3DV4 - SN3619; ConvF(4.37, 4.37, 4.37); Calibrated: 9/10/2007
- Sensor-Surface: 2mm (Mechanical Surface Detection)
- Electronics: DAE3 Sn456; Calibrated: 11/8/2007
- Phantom: SAM with CRP; Type: SAM; Serial: TP-1032
- Measurement SW: DASY4, V4.6 Build 23; Post processing SW: SEMCAD, V1.8 Build 184

d=10mm, Pin=0.5W/Area Scan (61x61x1): Measurement grid: dx=5mm, dy=5mm

Maximum value of SAR (interpolated) = 94.5 mW/g

d=10mm, Pin=0.5W/Zoom Scan (11x11x9)/Cube 0: Measurement grid: dx=3mm, dy=3mm, dz=2.5mm

Reference Value = 99.5 V/m; Power Drift = 0.615 dB

Peak SAR (extrapolated) = 189.5 W/kg

SAR (1 g) = 39.8 mW/g; SAR (10 g) = 11 mW/g

Maximum value of SAR (measured) = 90.5 mW/g

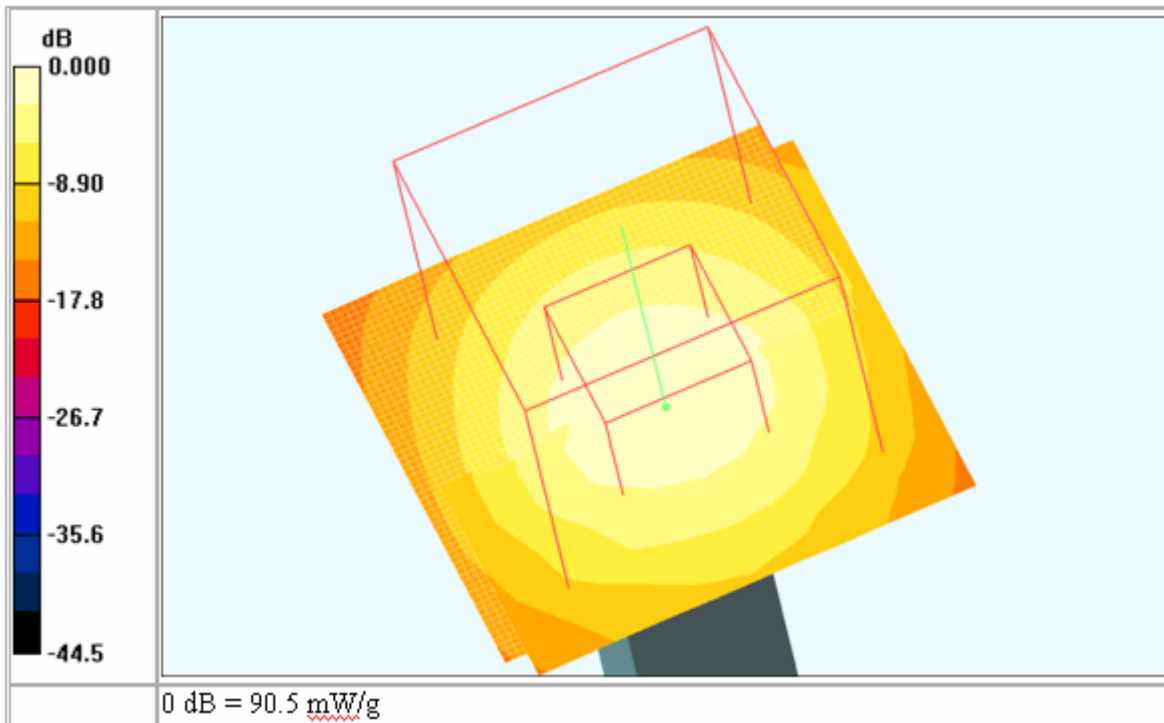

Test Laboratory: Bay Area Compliance Lab Corp. (BACL)

5800 MHz System Validation for Head

Dipole 5100MHZ; Type: D5100; Serial: D5100V2-SN: 1001

Communication System: CW; Frequency: 5800 MHz; Duty Cycle: 1:1
 Medium parameters used: $f = 5800 \text{ MHz}$; $\sigma = 5.03 \text{ mho/m}$; $\epsilon_r = 36.3$; $\rho = 1000 \text{ kg/m}^3$
 Phantom section: Flat Section

DASY4 Configuration:

- Probe: EX3DV4 - SN3619; ConvF(4.07, 4.07, 4.07); Calibrated: 9/10/2007
- Sensor-Surface: 2mm (Mechanical Surface Detection)
- Electronics: DAE3 Sn456; Calibrated: 11/8/2007
- Phantom: SAM with CRP; Type: SAM; Serial: TP-1032
- Measurement SW: DASY4, V4.6 Build 23; Post processing SW: SEMCAD, V1.8 Build 184

d=10mm, Pin=0.5W/Area Scan (61x61x1): Measurement grid: dx=5mm, dy=5mm
 Maximum value of SAR (interpolated) = 90.9 mW/g

d=10mm, Pin=0.5W/Zoom Scan (11x11x9)/Cube 0: Measurement grid: dx=3mm, dy=3mm, dz=2.5mm
 Reference Value = 91.5 V/m; Power Drift = 0.049 dB
 Peak SAR (extrapolated) = 193.1 W/kg

SAR (1 g) = 41.3 mW/g; SAR (10 g) = 11.5 mW/g
 Maximum value of SAR (measured) = 86.8 mW/g

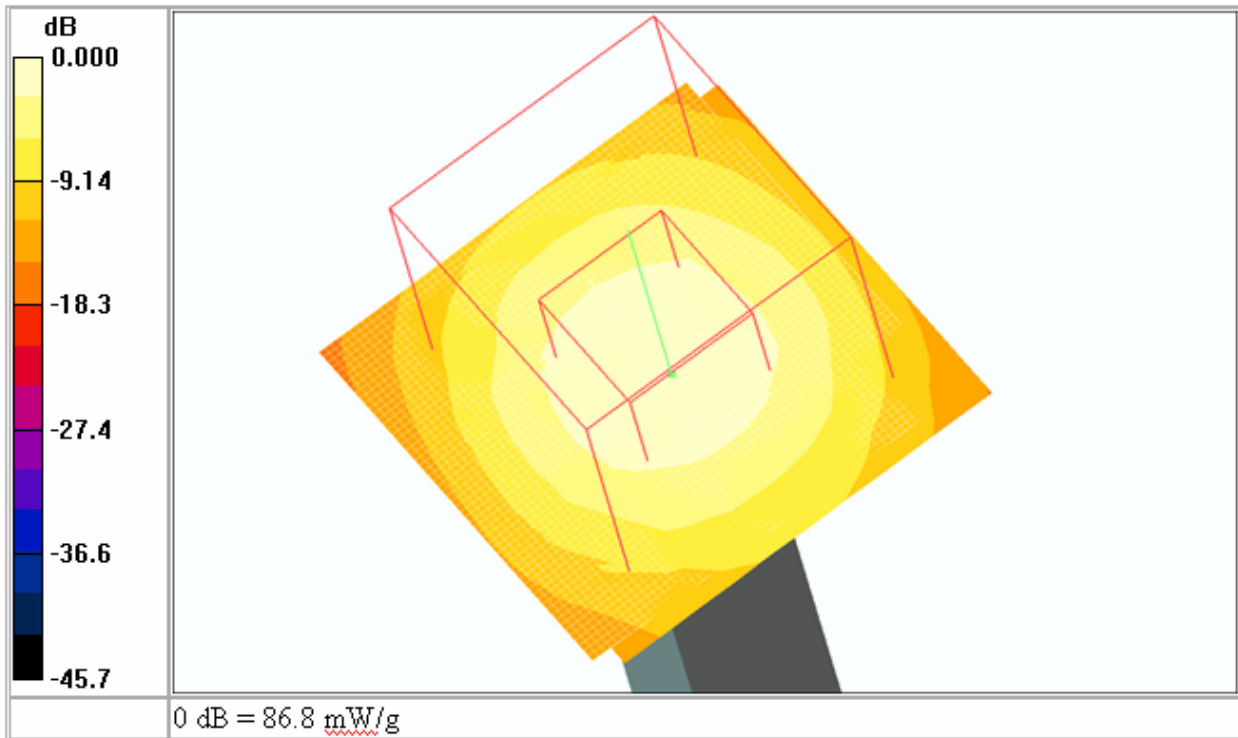

System Validation for Head Tissue

APPENDIX E - EUT SCANS

Test Laboratory: Bay Area Compliance Lab Corp. (BACL)
EUT Top Touch to the Flat Phantom 2417MHz
Psion Teklogix; Type: 7527 G2; Serial: B1793

Communication System: 802.11b; Frequency: 2417 MHz; Duty Cycle: 1:1
Medium parameters used (interpolated): $f = 2417$ MHz; $\sigma = 1.98$ mho/m; $\epsilon_r = 50.8$; $\rho = 1000$ kg/m³
Phantom section: Flat Section

DASY4 Configuration:

- Probe: ET3DV6 - SN1604; ConvF(4.11, 4.11, 4.11); Calibrated: 8/28/2007
- Sensor-Surface: 4mm (Mechanical Surface Detection)
- Electronics: DAE3 Sn456; Calibrated: 11/8/2007
- Phantom: SAM with CRP; Type: Twin SAM; Serial: TP-1032
- Measurement SW: DASY4, V4.7 Build 71; Postprocessing SW: SEMCAD, V1.8 Build 184

EUT Top Touching /Area Scan (61x101x1): Measurement grid: dx=15mm, dy=15mm
Maximum value of SAR (interpolated) = 0.040 mW/g

EUT Top Touching/Zoom Scan (7x7x7)/Cube 0: Measurement grid: dx=5mm, dy=5mm, dz=5mm
Reference Value = 3.23 V/m; Power Drift = 0.123 dB
Peak SAR (extrapolated) = 0.180 W/kg

SAR (1 g) = 0.026 mW/g; SAR (10 g) = 0.00792 mW/g
Maximum value of SAR (measured) = 0.052 mW/g

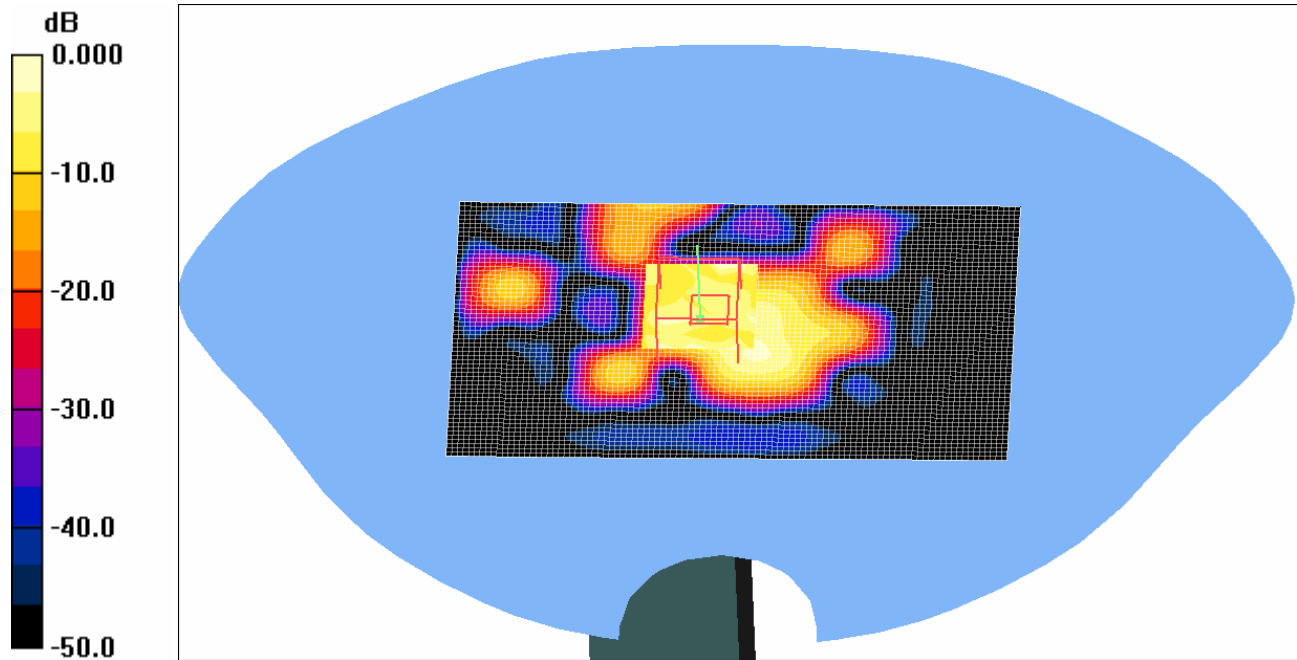

0 dB = 0.052 mW/g

Plot # 1

Test Laboratory: Bay Area Compliance Lab Corp. (BACL)
 EUT Top Touch to the Flat Phantom 2437 MHz
 Psion Teklogix; Type: 7527 G2; Serial: B1793

Communication System: 802.11b; Frequency: 2437 MHz; Duty Cycle: 1:1
 Medium parameters used (interpolated): $f = 2437$ MHz; $\sigma = 2.01$ mho/m; $\epsilon_r = 50.7$; $\rho = 1000$ kg/m³
 Phantom section: Flat Section

DASY4 Configuration:

- Probe: ET3DV6 - SN1604; ConvF(4.11, 4.11, 4.11); Calibrated: 8/28/2007
- Sensor-Surface: 4mm (Mechanical Surface Detection)
- Electronics: DAE3 Sn456; Calibrated: 11/8/2007
- Phantom: SAM with CRP; Type: Twin SAM; Serial: TP-1032
- Measurement SW: DASY4, V4.7 Build 71; Post processing SW: SEMCAD, V1.8 Build 184

EUT Top Touching Position/Area Scan (61x101x1): Measurement grid: dx=15mm, dy=15mm
 Maximum value of SAR (interpolated) = 0.044 mW/g

EUT Top Touching Position/Zoom Scan (7x7x7)/Cube 0: Measurement grid: dx=5mm, dy=5mm, dz=5mm
 Reference Value = 2.59 V/m; Power Drift = -0.403 dB
 Peak SAR (extrapolated) = 0.108 W/kg

SAR (1 g) = 0.022 mW/g; SAR (10 g) = 0.00748 mW/g
 Maximum value of SAR (measured) = 0.032 mW/g

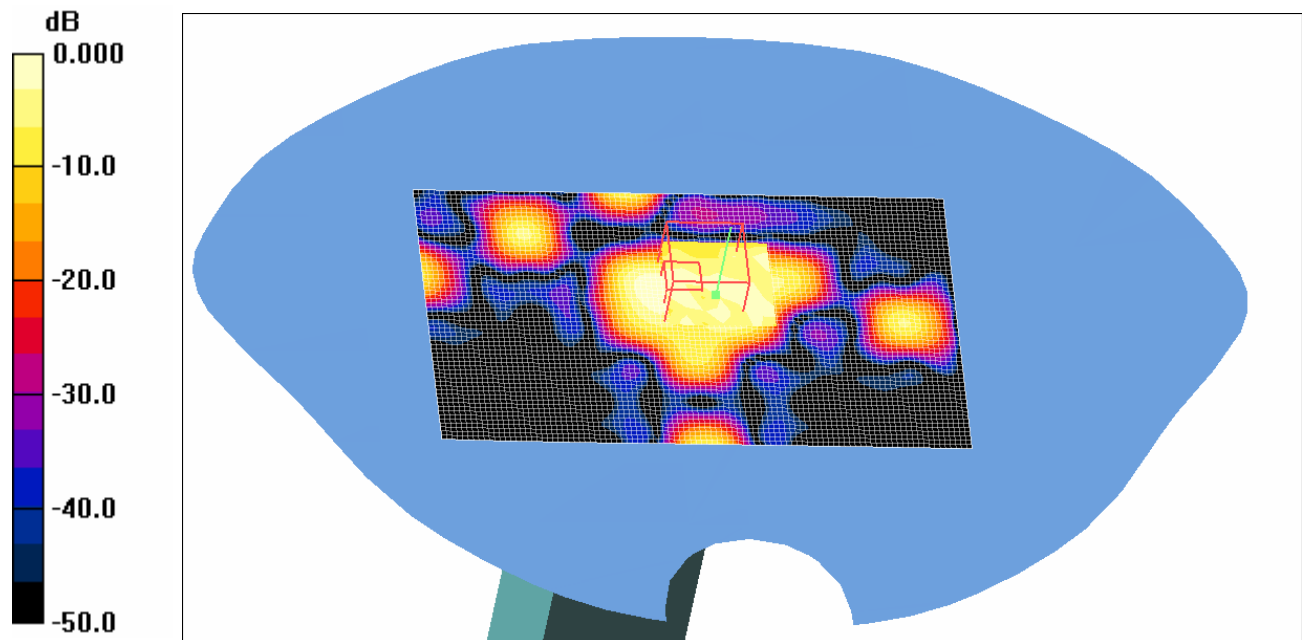

0 dB = 0.032 mW/g

Plot # 2

Test Laboratory: Bay Area Compliance Lab Corp. (BACL)
 EUT Top Touch to the Flat Phantom 2452 MHz
 Psion Teklogix; Type: 7527 G2; Serial: B1793

Communication System: 802.11b; Frequency: 2452 MHz; Duty Cycle: 1:1
 Medium parameters used (interpolated): $f = 2452$ MHz; $\sigma = 2.02$ mho/m; $\epsilon_r = 50.5$; $\rho = 1000$ kg/m³
 Phantom section: Flat Section

DASY4 Configuration:

- Probe: ET3DV6 - SN1604; ConvF(4.11, 4.11, 4.11); Calibrated: 8/28/2007
- Sensor-Surface: 4mm (Mechanical Surface Detection)
- Electronics: DAE3 Sn456; Calibrated: 11/8/2007
- Phantom: SAM with CRP; Type: Twin SAM; Serial: TP-1032
- Measurement SW: DASY4, V4.7 Build 71; Postprocessing SW: SEMCAD, V1.8 Build 184

EUT Top Touching Position/Area Scan (61x101x1): Measurement grid: dx=15mm, dy=15mm
 Maximum value of SAR (interpolated) = 0.030 mW/g

EUT Top Touching Position/Zoom Scan (7x7x7)/Cube 0: Measurement grid: dx=5mm, dy=5mm, dz=5mm
 Reference Value = 2.76 V/m; Power Drift = -0.195 dB
 Peak SAR (extrapolated) = 0.128 W/kg

SAR (1 g) = 0.033 mW/g; SAR (10 g) = 0.00791 mW/g
 Maximum value of SAR (measured) = 0.068 mW/g

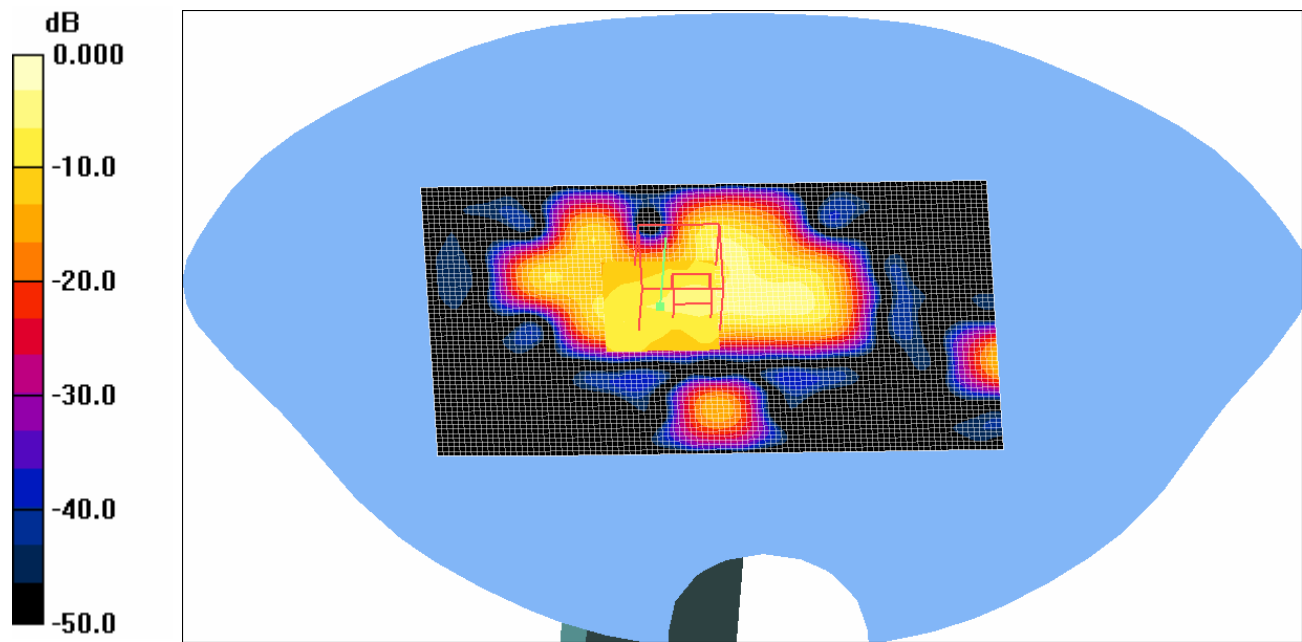

0 dB = 0.068 mW/g

Plot # 3

Test Laboratory: Bay Area Compliance Lab Corp. (BACL)
EUT Top Touch to the Flat Phantom 2417 MHz
Psion Teklogix; Type: 7527 G2; Serial: B1793

Communication System: 802.11g; Frequency: 2417 MHz; Duty Cycle: 1:1
Medium parameters used: $f = 2417$ MHz; $\sigma = 1.98$ mho/m; $\epsilon_r = 50.8$; $\rho = 1000$ kg/m³
Phantom section: Flat Section

DASY4 Configuration:

- Probe: ET3DV6 - SN1604; ConvF(4.11, 4.11, 4.11); Calibrated: 8/28/2007
- Sensor-Surface: 4mm (Mechanical Surface Detection)
- Electronics: DAE3 Sn456; Calibrated: 11/8/2007
- Phantom: SAM with CRP; Type: Twin SAM; Serial: TP-1032
- Measurement SW: DASY4, V4.7 Build 71; Post processing SW: SEMCAD, V1.8 Build 184

EUT Top Touching Position/Area Scan (61x101x1): Measurement grid: dx=15mm, dy=15mm
Maximum value of SAR (interpolated) = 0.059 mW/g

EUT Top Touching Position/Zoom Scan (7x7x7)/Cube 0: Measurement grid: dx=5mm, dy=5mm, dz=5mm
Reference Value = 3.09 V/m; Power Drift = 0.054 dB
Peak SAR (extrapolated) = 0.121 W/kg

SAR (1 g) = 0.038 mW/g; SAR (10 g) = 0.014 mW/g
Maximum value of SAR (measured) = 0.063 mW/g

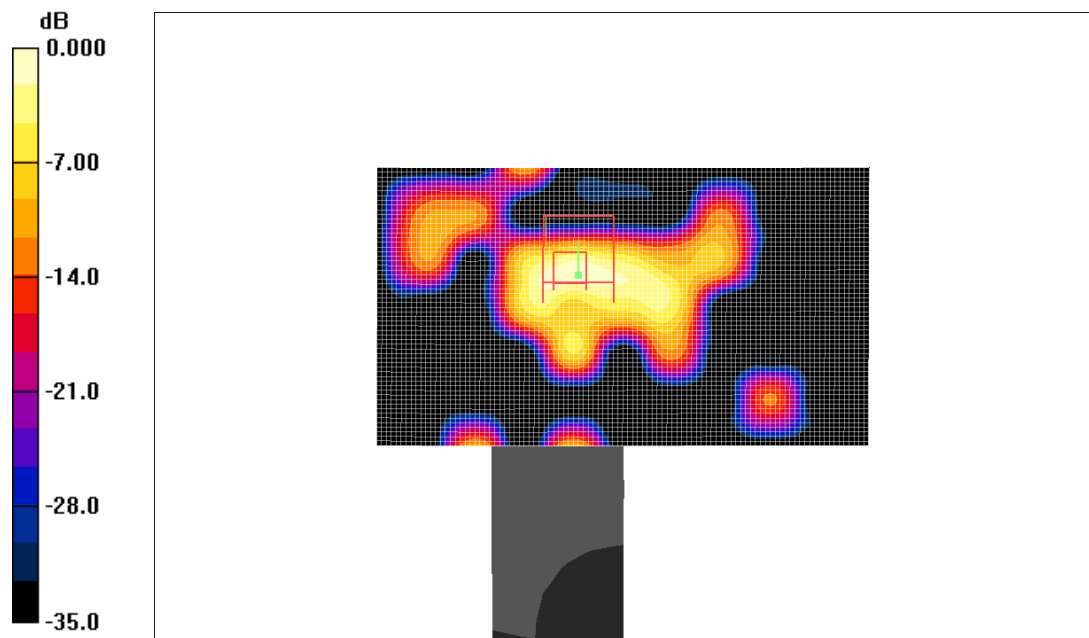

Plot # 4

Test Laboratory: Bay Area Compliance Lab Corp. (BACL)
EUT Top Touch to the Flat Phantom 2437 MHz
Psion Teklogix; Type: 7527 G2; Serial: B1793

Communication System: 802.11g; Frequency: 2437 MHz; Duty Cycle: 1:1
Medium parameters used: $f = 2437 \text{ MHz}$; $\sigma = 2.01 \text{ mho/m}$; $\epsilon_r = 50.7$; $\rho = 1000 \text{ kg/m}^3$
Phantom section: Flat Section

DASY4 Configuration:

- Probe: ET3DV6 - SN1604; ConvF(4.11, 4.11, 4.11); Calibrated: 8/28/2007
- Sensor-Surface: 4mm (Mechanical Surface Detection)
- Electronics: DAE3 Sn456; Calibrated: 11/8/2007
- Phantom: SAM with CRP; Type: Twin SAM; Serial: TP-1032
- Measurement SW: DASY4, V4.7 Build 71; Postprocessing SW: SEMCAD, V1.8 Build 184

EUT Top Touching Position/Area Scan (61x101x1): Measurement grid: $dx=15\text{mm}$, $dy=15\text{mm}$
Maximum value of SAR (interpolated) = 0.077 mW/g

EUT Top Touching Position/Zoom Scan (7x7x7)/Cube 0: Measurement grid: $dx=5\text{mm}$, $dy=5\text{mm}$, $dz=5\text{mm}$
Reference Value = 3.75 V/m; Power Drift = -0.27 dB
Peak SAR (extrapolated) = 0.299 W/kg

SAR (1 g) = 0.065 mW/g; SAR (10 g) = 0.022 mW/g
Maximum value of SAR (measured) = 0.075 mW/g

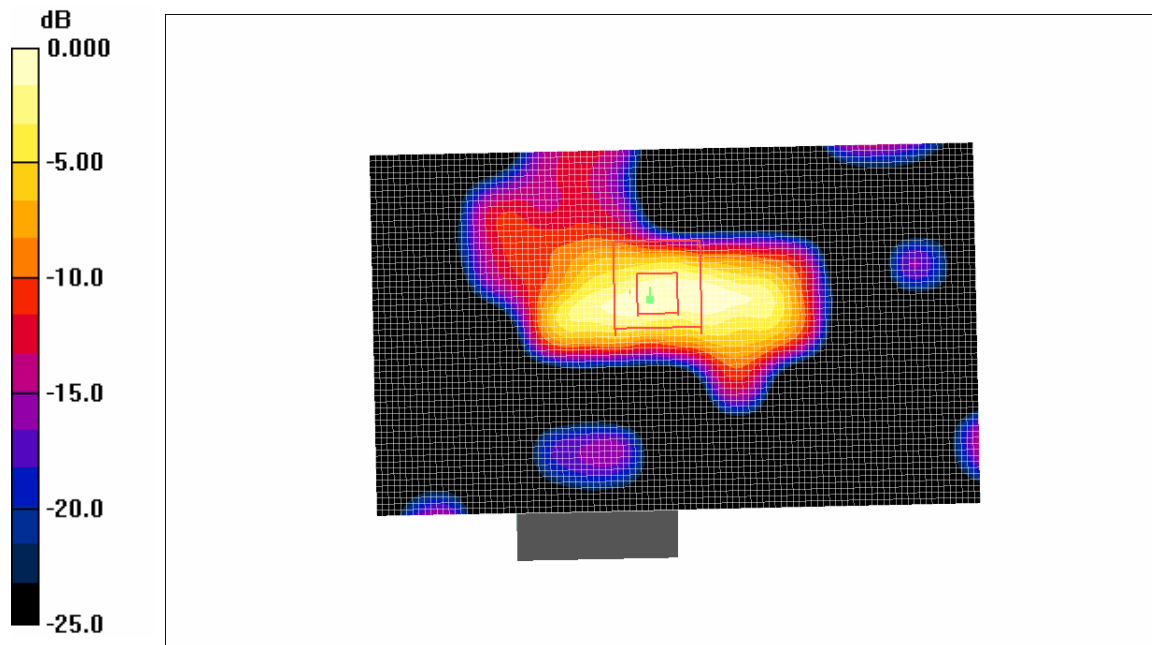

0 dB = 0.075mW/g

Plot # 5

Test Laboratory: Bay Area Compliance Lab Corp. (BACL)
EUT Top Touch to the Flat Phantom 2457 MHz
Psion Teklogix; Type: 7527 G2; Serial: B1793

Communication System: 802.11g; Frequency: 2452 MHz; Duty Cycle: 1:1
Medium parameters used: $f = 2452 \text{ MHz}$; $\sigma = 2.02 \text{ mho/m}$; $\epsilon_r = 50.5$; $\rho = 1000 \text{ kg/m}^3$
Phantom section: Flat Section

DASY4 Configuration:

- Probe: ET3DV6 - SN1604; ConvF(4.11, 4.11, 4.11); Calibrated: 8/28/2007
- Sensor-Surface: 4mm (Mechanical Surface Detection)
- Electronics: DAE3 Sn456; Calibrated: 11/8/2007
- Phantom: SAM with CRP; Type: Twin SAM; Serial: TP-1032
- Measurement SW: DASY4, V4.7 Build 71; Post processing SW: SEMCAD, V1.8 Build 184

EUT Top Touching Position/Area Scan (61x101x1): Measurement grid: $dx=15\text{mm}$, $dy=15\text{mm}$
Maximum value of SAR (interpolated) = 0.050 mW/g

EUT Top Touching Position/Zoom Scan (7x7x7)/Cube 0: Measurement grid: $dx=5\text{mm}$, $dy=5\text{mm}$, $dz=5\text{mm}$
Reference Value = 4.56 V/m; Power Drift = 0.120 dB
Peak SAR (extrapolated) = 0.101 W/kg

SAR (1 g) = 0.036 mW/g; SAR (10 g) = 0.010 mW/g
Maximum value of SAR (measured) = 0.075 mW/g

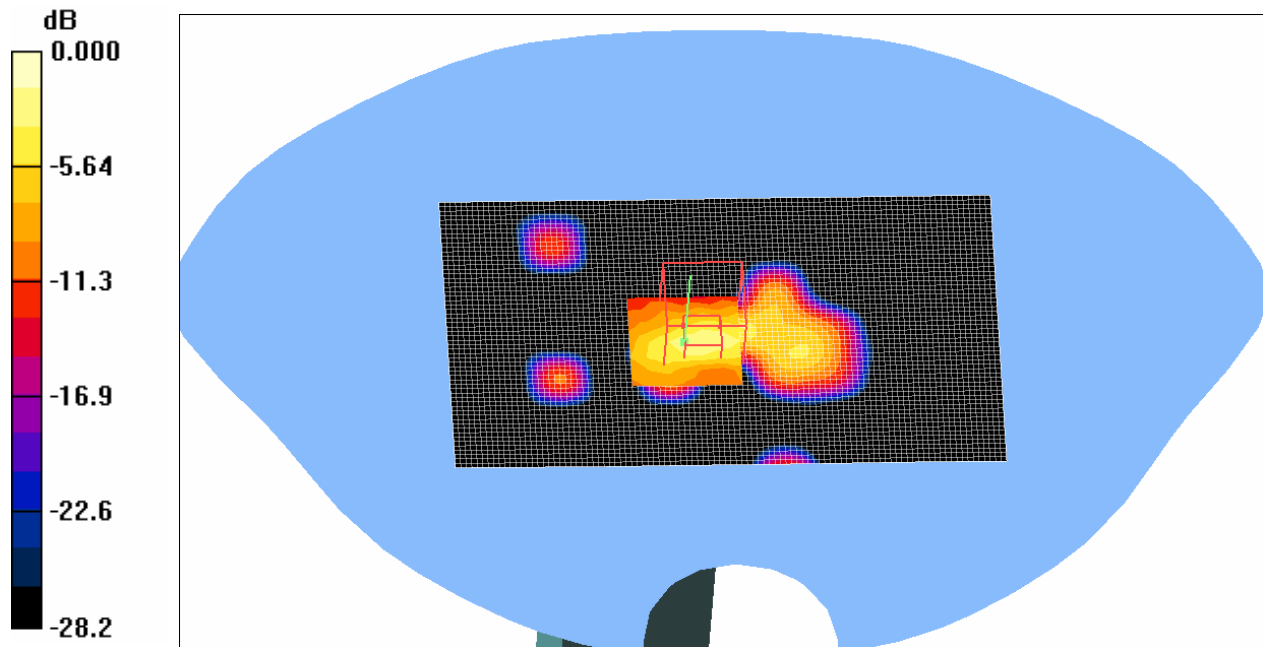

Plot # 6

Test Laboratory: Bay Area Compliance Lab Corp. (BACL)
 EUT Top Touch to the Flat Phantom 5180 MHz
 Psion Teklogix; Type: 7527C G2; Serial: B1793

Communication System: 802.11a; Frequency: 5180 MHz; Duty Cycle: 1:1
 Medium parameters used: $f = 5180 \text{ MHz}$; $\sigma = 5.22 \text{ mho/m}$; $\epsilon_r = 48.4$; $\rho = 1000 \text{ kg/m}^3$
 Phantom section: Flat Section

DASY4 Configuration:

- Probe: EX3DV4 - SN3619; ConvF(4.11, 4.11, 4.11); Calibrated: 9/10/2007
- Sensor-Surface: 4mm (Mechanical Surface Detection)
- Electronics: DAE3 Sn456; Calibrated: 11/8/2007
- Phantom: SAM with CRP; Type: Twin SAM; Serial: TP-1032
- Measurement SW: DASY4, V4.7 Build 71; Post processing SW: SEMCAD, V1.8 Build 184

EUT Top Touch Position/Area Scan (101x121x1): Measurement grid: $dx=10\text{mm}$, $dy=10\text{mm}$
 Maximum value of SAR (interpolated) = 0.161 mW/g

EUT Top Touch Position/Zoom Scan (11x11x11)/Cube 0: Measurement grid: $dx=3\text{mm}$, $dy=3\text{mm}$, $dz=2.5\text{mm}$
 Reference Value = 2.05 V/m; Power Drift = 0.406 dB
 Peak SAR (extrapolated) = 0.537 W/kg

SAR (1 g) = 0.151 mW/g; SAR (10 g) = 0.051 mW/g
 Maximum value of SAR (measured) = 0.309 mW/g

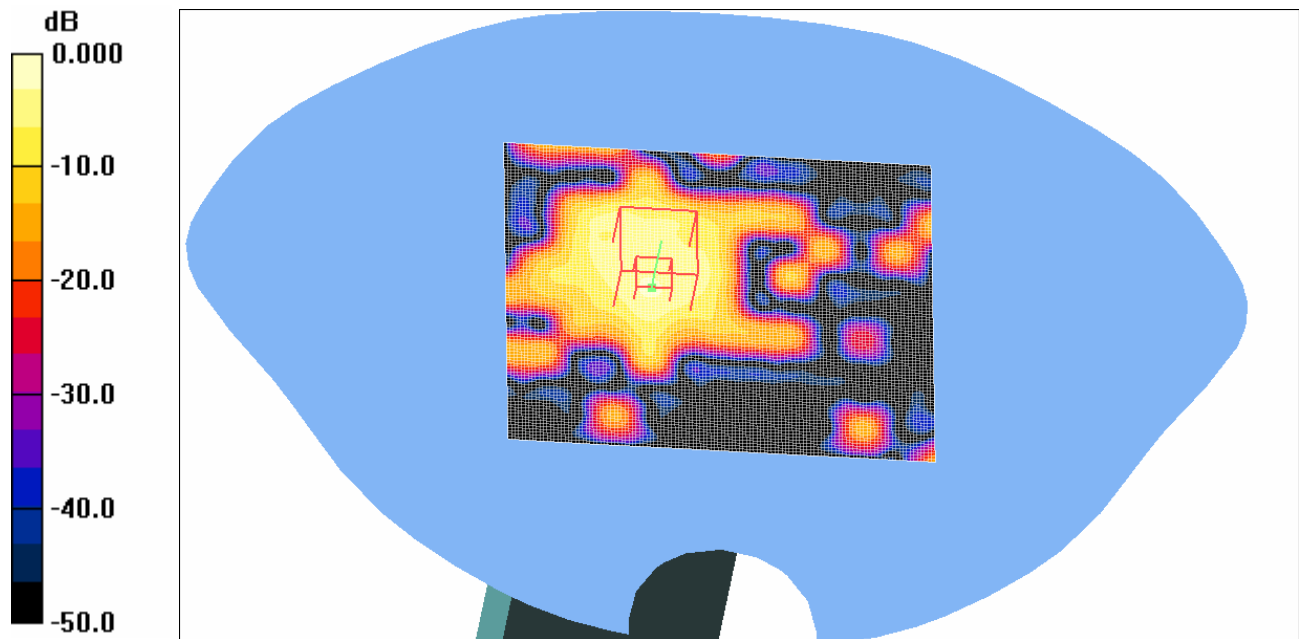

0 dB = 0.309 mW/g

Plot # 7

Test Laboratory: Bay Area Compliance Lab Corp. (BACL)
 EUT Top Touch to the Flat Phantom 5260MHz
 Psion Teklogix; Type: 7527C G2; Serial: B1793

Communication System: 802.11a; Frequency: 5260 MHz; Duty Cycle: 1:1
 Medium parameters used: $f = 5260 \text{ MHz}$; $\sigma = 5.28 \text{ mho/m}$; $\epsilon_r = 48$; $\rho = 1000 \text{ kg/m}^3$
 Phantom section: Flat Section DASY4 Configuration:

- Probe: EX3DV4 - SN3619; ConvF(4.11, 4.11, 4.11); Calibrated: 9/10/2007
- Sensor-Surface: 4mm (Mechanical Surface Detection)
- Electronics: DAE3 Sn456; Calibrated: 11/8/2007
- Phantom: SAM with CRP; Type: Twin SAM; Serial: TP-1032
- Measurement SW: DASY4, V4.7 Build 71; Post processing SW: SEMCAD, V1.8 Build 184

EUT Top Touching Position/Area Scan (101x121x1): Measurement grid: $dx=10\text{mm}$, $dy=10\text{mm}$
 Maximum value of SAR (interpolated) = 0.381 mW/g

EUT Top Touching Position/Zoom Scan (11x11x11)/Cube 0: Measurement grid: $dx=3\text{mm}$, $dy=3\text{mm}$, $dz=2.5\text{mm}$
 Reference Value = 3.09 V/m; Power Drift = -0.27 dB
 Peak SAR (extrapolated) = 0.445 W/kg

SAR (1 g) = 0.096 mW/g; SAR (10 g) = 0.034 mW/g
 Maximum value of SAR (measured) = 0.234 mW/g

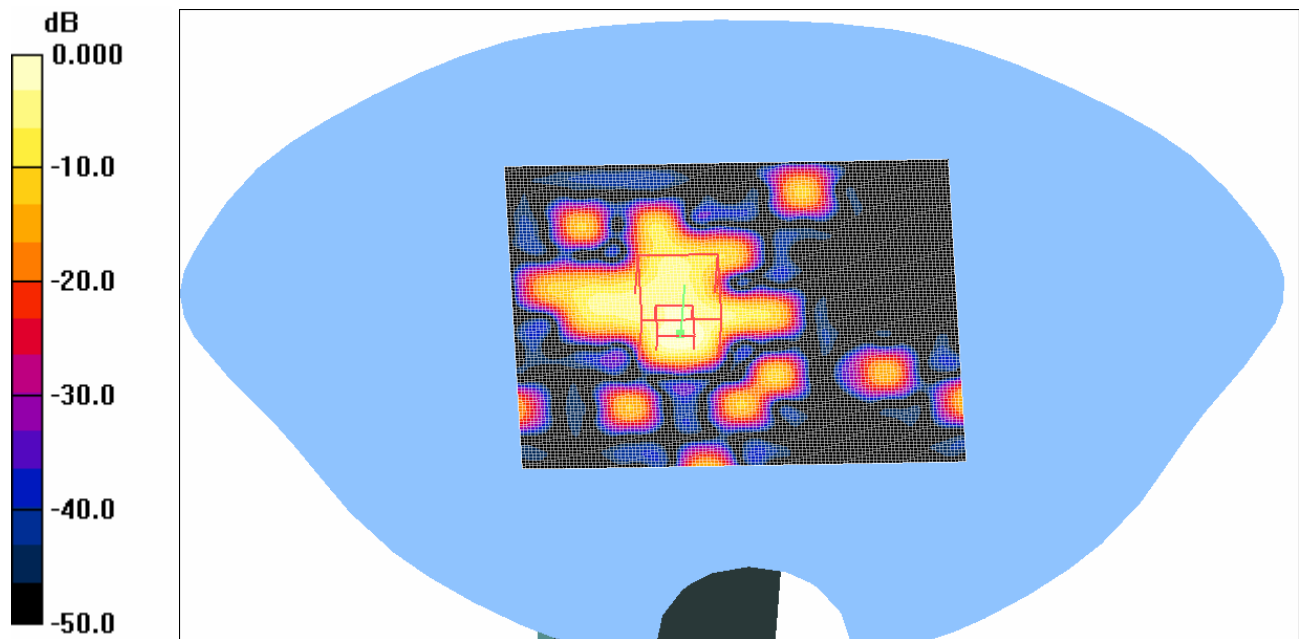

0 dB = 0.234 mW/g

Plot # 8

Test Laboratory: Bay Area Compliance Lab Corp. (BACL)
 EUT Top Touch to the Flat Phantom 5500MHz
 Psion Teklogix; Type: 7527C G2; Serial: B1793

Communication System: 802.11a; Frequency: 5500 MHz; Duty Cycle: 1:1
 Medium parameters used: $f = 5500 \text{ MHz}$; $\sigma = 5.72 \text{ mho/m}$; $\epsilon_r = 47.9$; $\rho = 1000 \text{ kg/m}^3$
 Phantom section: Flat Section

DASY4 Configuration:

- Probe: EX3DV4 - SN3619; ConvF(3.8, 3.8, 3.8); Calibrated: 9/10/2007
- Sensor-Surface: 4mm (Mechanical Surface Detection)
- Electronics: DAE3 Sn456; Calibrated: 11/8/2007
- Phantom: SAM with CRP; Type: Twin SAM; Serial: TP-1032
- Measurement SW: DASY4, V4.7 Build 71; Post processing SW: SEMCAD, V1.8 Build 184

EUT Top Touching Position/Area Scan (101x121x1): Measurement grid: $dx=10\text{mm}$, $dy=10\text{mm}$
 Maximum value of SAR (interpolated) = 0.246 mW/g

EUT Top Touching Position/Zoom Scan (11x11x11)/Cube 0: Measurement grid: $dx=3\text{mm}$, $dy=3\text{mm}$, $dz=2.5\text{mm}$
 Reference Value = 1.80 V/m; Power Drift = 0.40 dB
 Peak SAR (extrapolated) = 0.763 W/kg

SAR (1 g) = 0.202 mW/g; SAR (10 g) = 0.068 mW/g
 Maximum value of SAR (measured) = 0.423 mW/g

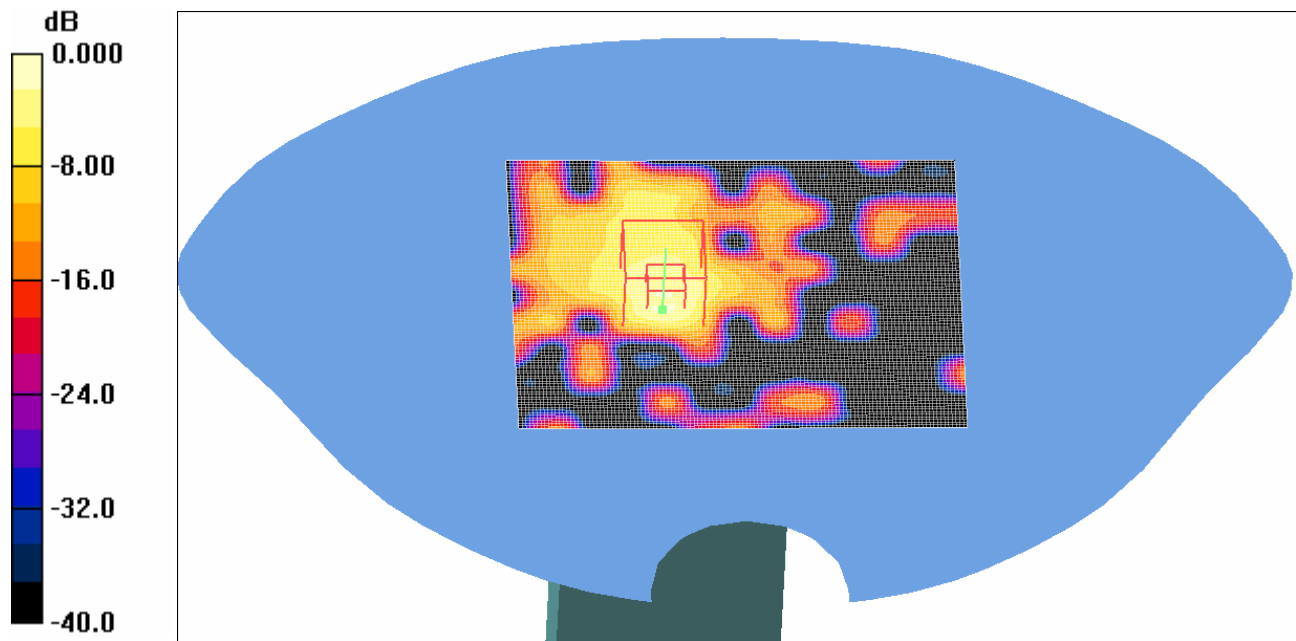

0 dB = 0.423 mW/g

Plot # 9

Test Laboratory: Bay Area Compliance Lab Corp. (BACL)
 EUT Top Touch to the Flat Phantom 5600MHz
 Psion Teklogix; Type: 7527C G2; Serial: B1793

Communication System: 802.11a; Frequency: 5600 MHz; Duty Cycle: 1:1
 Medium parameters used: $f = 5600 \text{ MHz}$; $\sigma = 5.83 \text{ mho/m}$; $\epsilon_r = 47.8$; $\rho = 1000 \text{ kg/m}^3$
 Phantom section: Flat Section

DASY4 Configuration:

- Probe: EX3DV4 - SN3619; ConvF(3.8, 3.8, 3.8); Calibrated: 9/10/2007
- Sensor-Surface: 4mm (Mechanical Surface Detection)
- Electronics: DAE3 Sn456; Calibrated: 11/8/2007
- Phantom: SAM with CRP; Type: Twin SAM; Serial: TP-1032
- Measurement SW: DASY4, V4.7 Build 71; Postprocessing SW: SEMCAD, V1.8 Build 184

EUT Top Touching Position/Area Scan (101x121x1): Measurement grid: $dx=10\text{mm}$, $dy=10\text{mm}$
 Maximum value of SAR (interpolated) = 0.274 mW/g

EUT Top Touching Position/Zoom Scan (11x11x11)/Cube 0: Measurement grid: $dx=3\text{mm}$, $dy=3\text{mm}$, $dz=2.5\text{mm}$
 Reference Value = 1.83 V/m; Power Drift = 0.27 dB
 Peak SAR (extrapolated) = 0.813 W/kg

SAR (1 g) = 0.214 mW/g; SAR (10 g) = 0.073 mW/g
 Maximum value of SAR (measured) = 0.459 mW/g

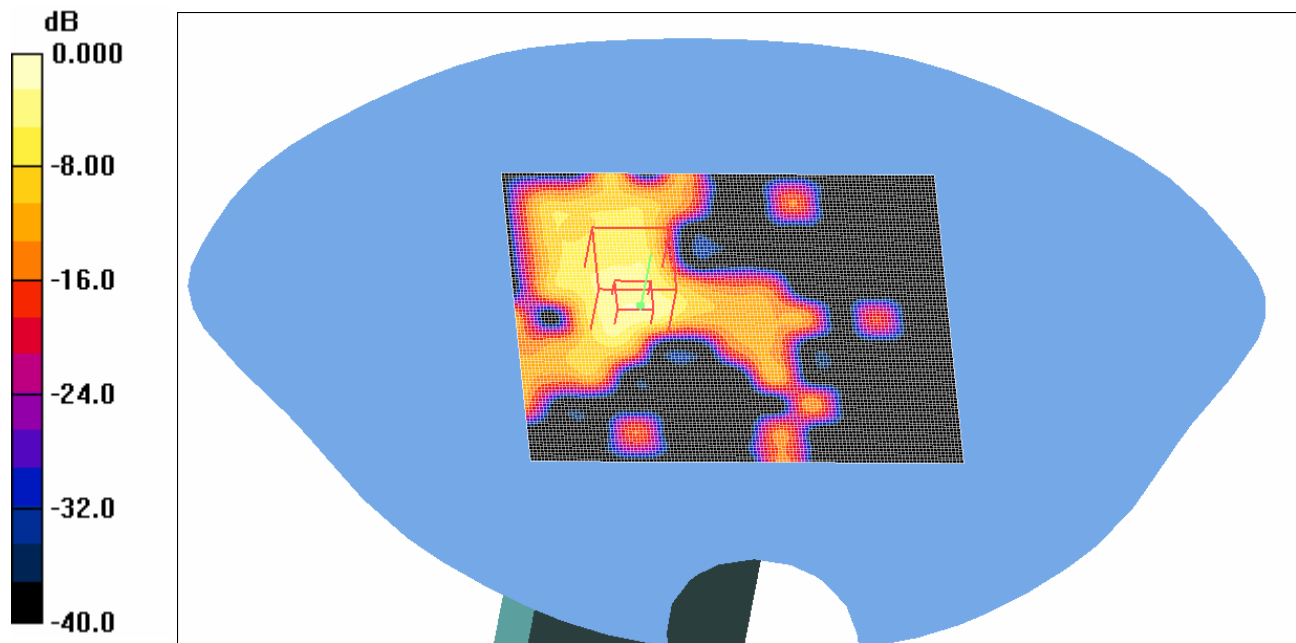

0 dB = 0.459 mW/g

Plot # 10

Test Laboratory: Bay Area Compliance Lab Corp. (BACL)
EUT Top Touch to the Flat Phantom 5700 MHz
Psion Teklogix; Type: 7527C G2; Serial: B1793

Communication System: 802.11a; Frequency: 5700 MHz; Duty Cycle: 1:1
Medium parameters used: $f = 5700$ MHz; $\sigma = 5.94$ mho/m; $\epsilon_r = 47.6$; $\rho = 1000$ kg/m³
Phantom section: Flat Section

DASY4 Configuration:

- Probe: EX3DV4 - SN3619; ConvF(4.08, 4.08, 4.08); Calibrated: 9/10/2007
- Sensor-Surface: 4mm (Mechanical Surface Detection)
- Electronics: DAE3 Sn456; Calibrated: 11/8/2007
- Phantom: SAM with CRP; Type: Twin SAM; Serial: TP-1032
- Measurement SW: DASY4, V4.7 Build 71; Post processing SW: SEMCAD, V1.8 Build 184

EUT Top Touching Position/Area Scan (101x121x1): Measurement grid: dx=10mm, dy=10mm
Maximum value of SAR (interpolated) = 0.123 mW/g

EUT Top Touching Position/Zoom Scan (11x11x11)/Cube 0: Measurement grid: dx=3mm, dy=3mm, dz=2.5mm
Reference Value = 0.976 V/m; Power Drift = 0.42 dB
Peak SAR (extrapolated) = 0.473 W/kg

SAR (1 g) = 0.117 mW/g; SAR (10 g) = 0.034 mW/g
Maximum value of SAR (measured) = 0.268 mW/g

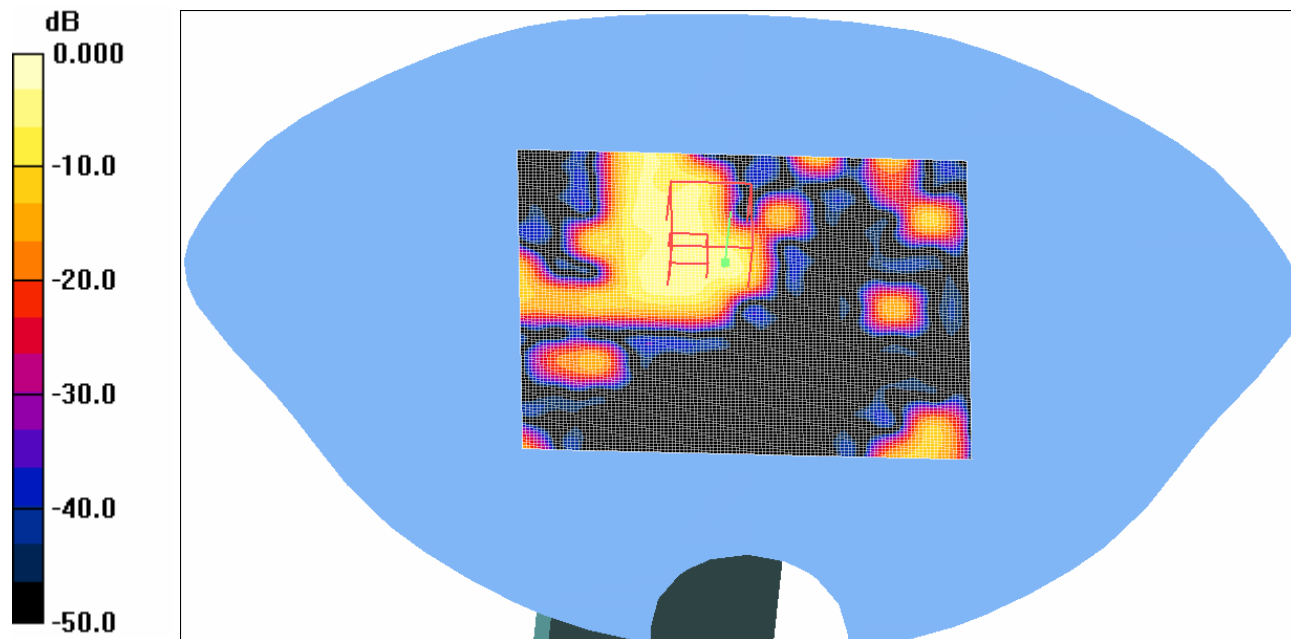

0 dB = 0.268 mW/g

Plot # 11

Test Laboratory: Bay Area Compliance Lab Corp. (BACL)
EUT Top Touch to the Flat Phantom 5745MHz
Psion Teklogix; Type: 7527C G2; Serial: B1793

Communication System: 802.11a; Frequency: 5745 MHz; Duty Cycle: 1:1
Medium parameters used: $f = 5745 \text{ MHz}$; $\sigma = 6.08 \text{ mho/m}$; $\epsilon_r = 47.5$; $\rho = 1000 \text{ kg/m}^3$
Phantom section: Flat Section

DASY4 Configuration:

- Probe: EX3DV4 - SN3619; ConvF(4.08, 4.08, 4.08); Calibrated: 9/10/2007
- Sensor-Surface: 4mm (Mechanical Surface Detection)
- Electronics: DAE3 Sn456; Calibrated: 11/8/2007
- Phantom: SAM with CRP; Type: Twin SAM; Serial: TP-1032
- Measurement SW: DASY4, V4.7 Build 71; Post processing SW: SEMCAD, V1.8 Build 184

EUT Top Touching Position/Area Scan (101x121x1): Measurement grid: $dx=10\text{mm}$, $dy=10\text{mm}$
Maximum value of SAR (interpolated) = 0.128 mW/g

EUT Top Touching Position/Zoom Scan (11x11x11)/Cube 0: Measurement grid: $dx=3\text{mm}$, $dy=3\text{mm}$, $dz=2.5\text{mm}$
Reference Value = 1.06 V/m; Power Drift = -0.199 dB
Peak SAR (extrapolated) = 0.365 W/kg

SAR (1 g) = 0.060 mW/g; SAR (10 g) = 0.021 mW/g
Maximum value of SAR (measured) = 0.156 mW/g

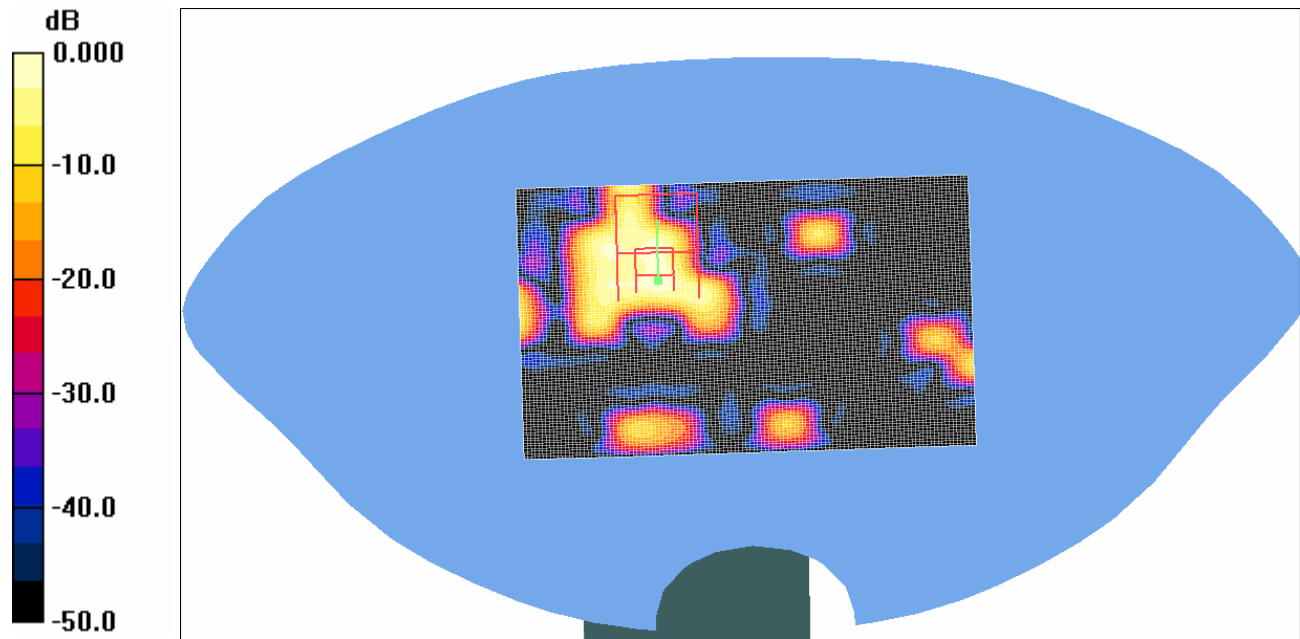

0 dB = 0.156 mW/g

Plot # 12

Test Laboratory: Bay Area Compliance Lab Corp. (BACL)
 EUT Top Touch to the Flat Phantom 5785MHz
 Psion Teklogix; Type: 7527C G2; Serial: B1793

Communication System: 802.11a; Frequency: 5785 MHz; Duty Cycle: 1:1
 Medium parameters used: $f = 5785 \text{ MHz}$; $\sigma = 6.09 \text{ mho/m}$; $\epsilon_r = 47.4$; $\rho = 1000 \text{ kg/m}^3$
 Phantom section: Flat Section

DASY4 Configuration:

- Probe: EX3DV4 - SN3619; ConvF(4.08, 4.08, 4.08); Calibrated: 9/10/2007
- Sensor-Surface: 4mm (Mechanical Surface Detection)
- Electronics: DAE3 Sn456; Calibrated: 11/8/2007
- Phantom: SAM with CRP; Type: Twin SAM; Serial: TP-1032
- Measurement SW: DASY4, V4.7 Build 71; Post processing SW: SEMCAD, V1.8 Build 184

EUT Top Touching Position/Area Scan (101x121x1): Measurement grid: $dx=10\text{mm}$, $dy=10\text{mm}$
 Maximum value of SAR (interpolated) = 0.095 mW/g

EUT Top Touching Position/Zoom Scan (11x11x11)/Cube 0: Measurement grid: $dx=3\text{mm}$, $dy=3\text{mm}$, $dz=2.5\text{mm}$
 Reference Value = 0.733 V/m; Power Drift = 0.2 dB
 Peak SAR (extrapolated) = 0.384 W/kg

SAR (1 g) = 0.055 mW/g; SAR (10 g) = 0.019 mW/g
 Maximum value of SAR (measured) = 0.142 mW/g

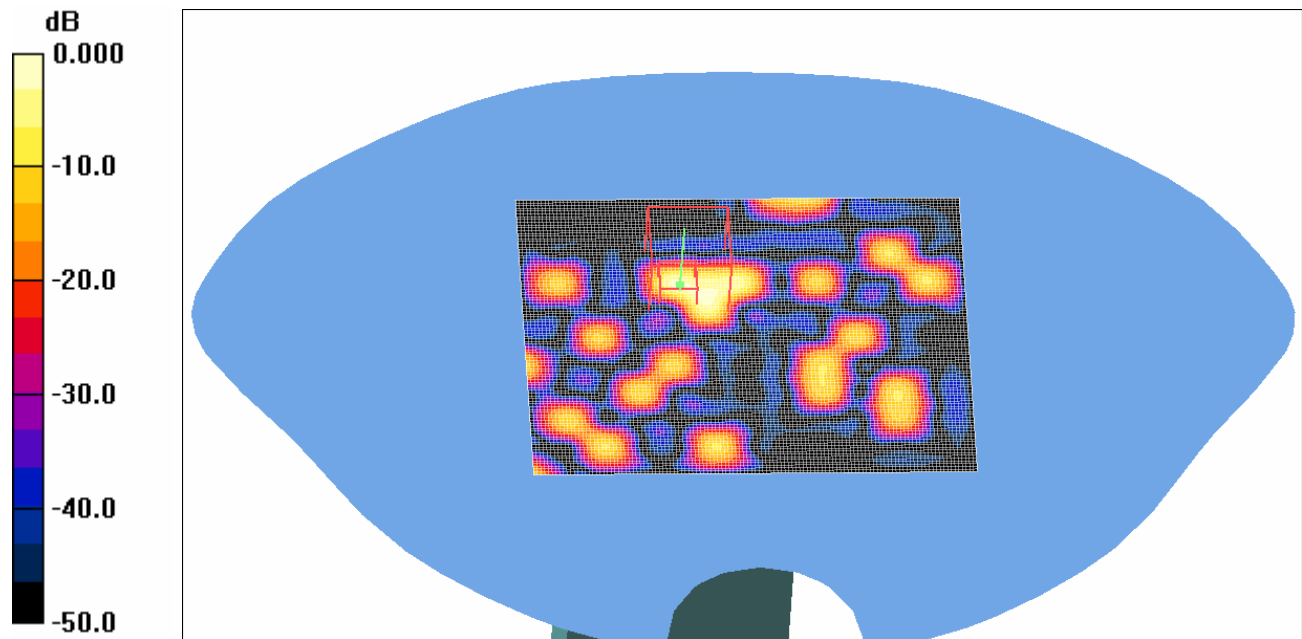

0 dB = 0.142 mW/g

Plot # 13

Test Laboratory: Bay Area Compliance Lab Corp. (BACL)
EUT Top Touch to the Flat Phantom 5825MHz
Psion Teklogix; Type: 7527CG2; Serial: B1793

Communication System: 802.11a; Frequency: 5825 MHz; Duty Cycle: 1:1
Medium parameters used: $f = 5825 \text{ MHz}$; $\sigma = 6.10 \text{ mho/m}$; $\epsilon_r = 47.4$; $\rho = 1000 \text{ kg/m}^3$
Phantom section: Flat Section

DASY4 Configuration:

- Probe: EX3DV4 - SN3619; ConvF(4.08, 4.08, 4.08); Calibrated: 9/10/2007
- Sensor-Surface: 4mm (Mechanical Surface Detection)
- Electronics: DAE3 Sn456; Calibrated: 11/8/2007
- Phantom: SAM with CRP; Type: Twin SAM; Serial: TP-1032
- Measurement SW: DASY4, V4.7 Build 71; Post processing SW: SEMCAD, V1.8 Build 184

EUT Top Touching Position/Area Scan (101x121x1): Measurement grid: $dx=10\text{mm}$, $dy=10\text{mm}$
Maximum value of SAR (interpolated) = 0.054 mW/g

EUT Top Touching Position/Zoom Scan (11x11x11)/Cube 0: Measurement grid: $dx=3\text{mm}$, $dy=3\text{mm}$, $dz=2.5\text{mm}$
Reference Value = 1.34 V/m; Power Drift = 0.77 dB
Peak SAR (extrapolated) = 0.466 W/kg

SAR (1 g) = 0.047 mW/g; SAR (10 g) = 0.017 mW/g
Maximum value of SAR (measured) = 0.109 mW/g

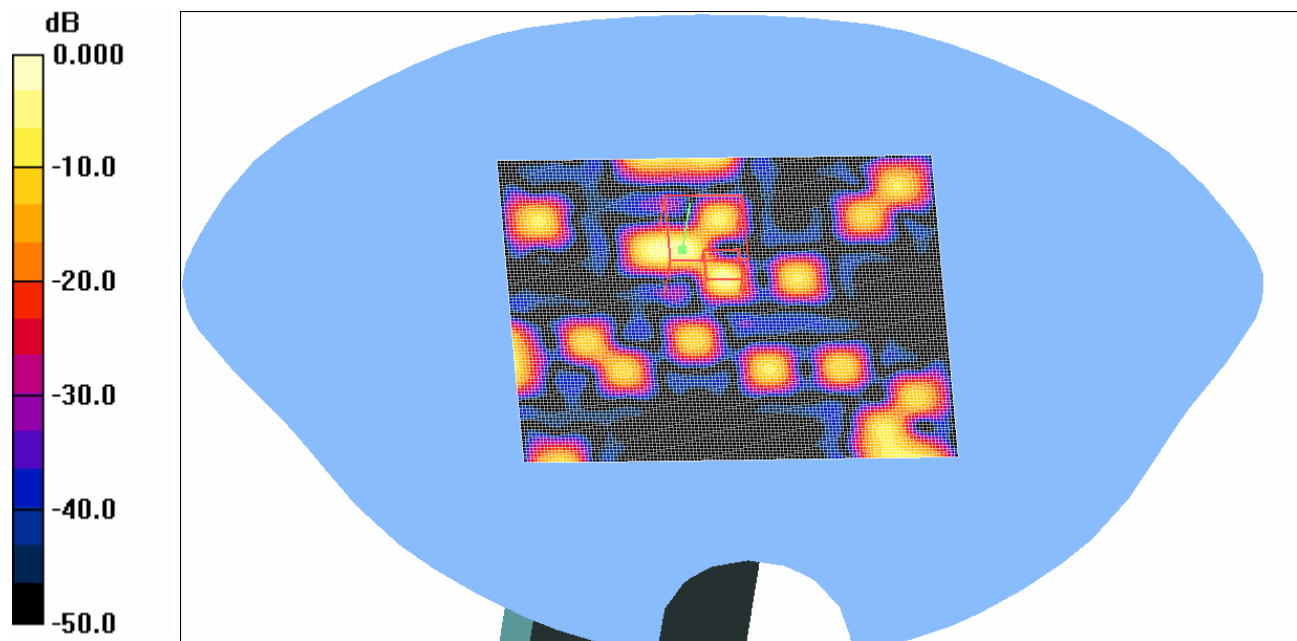

0 dB = 0.109 mW/g

Plot # 14

APPENDIX F – CONDUCTED OUTPUT POWER MEASUREMENT

Provision Applicable

The measured peak output power should be greater and within 5% than EMI measurement.

Test Procedure

The RF output of the transmitter was connected to the input of the spectrum analyzer through sufficient attenuation.



Test Equipment List

Manufacturer	Description	Model No.	Serial No.	Calibration Date
Agilent	Analyzer, Spectrum	E4440A	MY44303352	2008-04-28

Test Results

802.11b Mode (2.4GHz):

Channel No.	Frequency (MHz)	Measured Output Power	
		(dBm)	(mW)
2	2417	18	63.1
6	2437	19	79.43
9	2452	19.4	87.1

802.11g Mode (2.4GHz):

Channel No.	Frequency (MHz)	Measured Output Power	
		(dBm)	(mW)
2	2417	17.5	56.2
6	2437	20	100
9	2452	18.8	55.0

802.11a Mode:

Channel No.	Frequency (MHz)	Measured Output Power	
		(dBm)	(mW)
36	5180	17	26.5
52	5260	24	27.7
100	5500	15.79	37.9
126	5600	15.6	36.3
140	5700	15.41	34.8
149	5745	18.2	66.1
157	5785	17.8	60.3
165	5825	17.6	57.5

APPENDIX G – EUT TEST POSITION PHOTOS

EUT Top Side touching to the flat phantom



APPENDIX H- EUT PHOTO

EUT – Front Side View



EUT – Bottom Side View



EUT – Left Side View



EUT – Top Side View



EUT – Cover off View

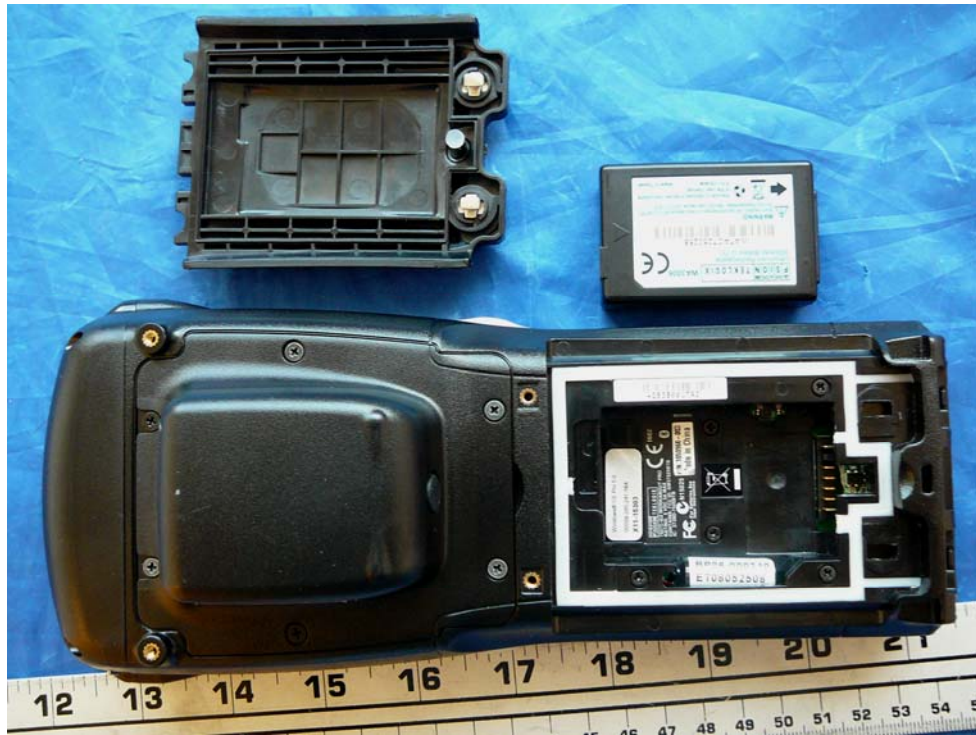

EUT – Battery View



APPENDIX I - INFORMATIVE REFERENCES

- [1] Federal Communications Commission, "Report and order: Guidelines for evaluating the environmental effects of radiofrequency radiation", Tech. Rep. FCC 96-326, FCC, Washington, D.C. 20554, 1996.
- [2] David L. Means Kwok Chan, Robert F. Cleveland, "Evaluating compliance with FCC guidelines for human exposure to radiofrequency electromagnetic fields", Tech. Rep., Federal Communication Commission, Office of Engineering & Technology, Washington, DC, 1997.
- [3] Thomas Schmid, Oliver Egger, and Niels Kuster, "Automated E-field scanning system for dosimetric assessments", IEEE Transactions on Microwave Theory and Techniques, vol. 44, pp. 105-113, Jan. 1996.
- [4] Niels Kuster, Ralph Kastle, and Thomas Schmid, "Dosimetric evaluation of mobile communications equipment with known precision", IEEE Transactions on Communications, vol. E80-B, no. 5, pp. 645-652, May 1997.
- [5] CENELEC, "Considerations for evaluating of human exposure to electromagnetic fields (EMFs) from mobile telecommunication equipment (MTE) in the frequency range 30MHz - 6GHz", Tech. Rep., CENELEC, European Committee for Electrotechnical Standardization, Brussels, 1997.
- [6] ANSI, ANSI/IEEE C95.1-1992: IEEE Standard for Safety Levels with Respect to Human Exposure to Radio Frequency Electromagnetic Fields, 3 kHz to 300 GHz, The Institute of Electrical and Electronics Engineers, Inc., New York, NY 10017, 1992.
- [7] Katja Pokovic, Thomas Schmid, and Niels Kuster, "Robust setup for precise calibration of E-field probes in tissue simulating liquids at mobile communications frequencies", in ICECOM '97, Dubrovnik, October 15-17, 1997, pp. 120-24.
- [8] Katja Pokovic, Thomas Schmid, and Niels Kuster, "E-field probe with improved isotropy in brain simulating liquids", in Proceedings of the ELMAR, Zadar, Croatia, 23-25 June, 1996, pp. 172-175.
- [9] Volker Hombach, Klaus Meier, Michael Burkhardt, Eberhard Kuhn, and Niels Kuster, "The dependence of EM energy absorption upon human head modeling at 900 MHz", IEEE Transactions on Microwave Theory and Techniques, vol. 44, no. 10, pp. 1865-1873, Oct. 1996.
- [10] Klaus Meier, Ralf Kastle, Volker Hombach, Roger Tay, and Niels Kuster, "The dependence of EM energy absorption upon human head modeling at 1800 MHz", IEEE Transactions on Microwave Theory and Techniques, Oct. 1997, in press.
- [11] W. Gander, Computermathematik, Birkhaeuser, Basel, 1992.
- [12] W. H. Press, S. A. Teukolsky, W. T. Vetterling, and B. P. Flannery, Numerical Recipes in C, The Art of Scientific Computing, Second Edition, Cambridge University Press, 1992. Dosimetric Evaluation of Sample device, month 1998 9
- [13] NIS81 NAMAS, "The treatment of uncertainty in EMC measurement", Tech. Rep., NAMAS Executive, National Physical Laboratory, Teddington, Middlesex, England, 1994.
- [14] Barry N. Taylor and Christ E. Kuyatt, "Guidelines for evaluating and expressing the uncertainty of NIST measurement results", Tech. Rep., National Institute of Standards and Technology, 1994. Dosimetric Evaluation of Sample device, month 1998 10.
- [15] SAR measurement procedures for 802.11a/b/g transmitters, Laboratory Division Office of Engineering and Technology FCC, October 2006
- [16] SAR measurement procedures for 3-6GHz device, Laboratory Division Office of Engineering and Technology FCC, October 2006.

***** END OF REPORT *****