

# ENGINEERING TEST REPORT

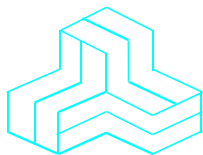

## WORKABOUT PRO Handheld Computer Co-Location RFID with 802.11b/g Wireless LAN and Bluetooth Model No.: 7527C

### Tested For

**Psion Teklogix Inc.**  
2100 Meadowvale Blvd.  
Mississauga, ON  
Canada, L5N 7J9

### In Accordance With

**SAR (Specific Absorption Rate) Requirements  
using guidelines established in IEEE Standard C95.1,  
FCC OET Bulletin 65 (Supplement C),  
Industry Canada RSS-102(Issue 2),  
EN 50360 (Council Recommendation 1999/519/EC) and  
ACA 2003 / ARPANSA Standard**

**UltraTech's File No.: TEK-602-SAR**

This Test report is Issued under the Authority of  
Tri M. Luu, Professional Engineer,  
Vice President of Engineering  
UltraTech Group of Labs



Date: August 8, 2007

Report Prepared by:  
JaeWook Choi

Issued Date:  
August 8, 2007

*The results in this Test Report apply only to the sample(s) tested, which has been randomly selected.*

---

## UltraTech

3000 Bristol Circle, Oakville, Ontario, Canada, L6H 6G4  
Telephone (905) 829-1570 Facsimile (905) 829-8050  
Website: [www.ultratech-labs.com](http://www.ultratech-labs.com) Email: [vic@ultratech-labs.com](mailto:vic@ultratech-labs.com)

## TABLE OF CONTENTS

**EXHIBIT 1. PERFORMANCE ASSESSMENT ..... 2**

1.1. CLIENT AND MANUFACTURER INFORMATION ..... 2

1.2. DEVICE UNDER TEST (D.U.T.) DESCRIPTION..... 2

**EXHIBIT 2. COLOCATION RFID WITH 802.11B/G WIRELESS LAN AND BLUETOOTH ..... 5**

2.1. APPLICABILITY & SUMMARY OF SAR RESULTS..... 5

2.1.1. *Summary of Peak Spatial-Average SAR in the Body Configuration*..... 6

2.1.1.1. Summary of Peak Spatial-Average SAR in the Body Configuration for RFID ..... 6

2.1.1.2. Summary of Peak Spatial-Average SAR in the Body Configuration for Bluetooth..... 6

2.1.1.3. Summary of Peak Spatial-Average SAR in the Body Configuration for 802.11b/g Wireless LAN ..... 7

2.1.1.3.1. Keypad Up With 1.5 cm Gap..... 7

2.1.1.3.2. Keypad Down With 1.5 cm Gap ..... 7

2.1.1.3.3. Holster Left Side Touch..... 8

2.1.1.3.4. Holster Right Side Touch..... 8

2.1.2. *Maximum Peak Spatial-Average SAR in the Body Configuration*..... 9

2.1.2.1. Maximum Peak Spatial-Average SAR in the Body Configuration for RFID ..... 9

2.1.2.2. Maximum Peak Spatial-Average SAR in the Body Configuration for Bluetooth..... 9

2.1.2.3. Maximum Peak Spatial-Average SAR in the Body Configuration for 802.11b/g Wireless LAN..... 9

2.1.2.3.1. Holster Left Side Touch..... 9

2.1.3. *Maximum Peak Spatial-Average SAR for Co-location RFID, Bluetooth and 802.11b/g Wireless LAN* ..... 10

2.2. SAR MEASUREMENT UNCERTAINTY ..... 11

**ULTRATECH GROUP OF LABS**

3000 Bristol Circle, Oakville, Ontario, Canada L6H 6G4  
Tel. #: 905-829-1570, Fax. #: 905-829-8050, Email: vic@ultratech-labs.com, Website: http://www.ultratech-labs.com

**File #: TEK-602-SAR**  
**August 8, 2007**

- Assessed by ITI (UK) Competent Body, NVLAP (USA) Accreditation Body & ACA/AUSTEL (Australia), VCCI (Japan)
- Accredited by Industry Canada (Canada) under ACC-LAB (Europe/Canada MRA and APEC/Canada MRA)
- Recognized/Listed by FCC (USA )
- All test results contained in this engineering test report are traceable to National Institute of Standards and Technology (NIST)

## EXHIBIT 1. PERFORMANCE ASSESSMENT

### 1.1. CLIENT AND MANUFACTURER INFORMATION

<b>APPLICANT:</b>	
<b>Name:</b>	Psion Teklogix Inc.
<b>Address:</b>	2100 Meadowvale Blvd. Mississauga, ON Canada, L5N 7J9
<b>Contact Person:</b>	Mr. Sada Dharwarkar Phone #: +1.905.812.6200 ext. 3358 Fax #: +1.905.812.6301 Email Address: <a href="mailto:Sada.dharwarkar@psionteklogix.com">Sada.dharwarkar@psionteklogix.com</a>

<b>MANUFACTURER:</b>	
<b>Name:</b>	Psion Teklogix Inc.
<b>Address:</b>	2100 Meadowvale Blvd. Mississauga, ON Canada, L5N 7J9
<b>Contact Person:</b>	Mr. Sada Dharwarkar Phone #: +1.905.812.6200 ext. 3358 Fax #: +1.905.812.6301 Email Address: <a href="mailto:Sada.dharwarkar@psionteklogix.com">Sada.dharwarkar@psionteklogix.com</a>

### 1.2. DEVICE UNDER TEST (D.U.T.) DESCRIPTION

The following is the information provided by the applicant.

<b>Trade Name</b>	Psion Teklogix WORKABOUT PRO
<b>Product Description</b>	Handheld Computer
<b>Type/Model Number</b>	7527C contains the following three radios: #1. WJRFID RFID module #2. RA2041 802.11b/g Wireless Lan module #3. BTL040 Bluetooth module
<b>Power Supply</b>	Lithium Ion Rechargeable 3000 mAh Battery (3.7V), Psion Teklogix Model No.: WA3006
<b>Primary User Functions of D.U.T.</b>	Provide data communication link through air

#### ULTRATECH GROUP OF LABS

3000 Bristol Circle, Oakville, Ontario, Canada L6H 6G4  
Tel. #: 905-829-1570, Fax. #: 905-829-8050, Email: vic@ultratech-labs.com, Website: http://www.ultratech-labs.com

File #: **TEK-602-SAR**  
August 8, 2007

- Assessed by ITI (UK) Competent Body, NVLAP (USA) Accreditation Body & ACA/AUSTEL (Australia), VCCI (Japan)
- Accredited by Industry Canada (Canada) under ACC-LAB (Europe/Canada MRA and APEC/Canada MRA)
- Recognized/Listed by FCC (USA)
- All test results contained in this engineering test report are traceable to National Institute of Standards and Technology (NIST)

**SPECIFIC ABSORPTION RATE (SAR)**

IEEE C95.1-1991, FCC OET Bulletin 65 (Supplement C), Industry Canada RSS-102(Issue 2) and ACA Radiocommunications (Electromagnetic Radiation – Human Exposure) Amendment Standard 2000 (No. 1)

**WORKABOUT PRO G2 Handheld Computer M/N: 7527C****FCC ID: GM37527CBTRA2041M**

<b>Radio #1- RFID</b>	
<i>Location</i>	PCMCIA SLOT
<i>Manufacturer:</i>	WJ
<i>Product</i>	WJRFID
<i>Model number</i>	MPR6000
<i>Psion teklogix model number</i>	N/A
<i>Serial number</i>	
<i>Transmitter power</i>	0.5 Watt
<i>Frequency range</i>	902-928 MHz
<i>Type of modulation</i>	Frequency Hopping Spread Spectrum
<i>Data rates</i>	
<i>Channels</i>	79
<i>Internal/extrenal antenna</i>	External (Inside the Host)

<b>Radio #2 – 802.11b/g Wireless LAN</b>	
<i>Location</i>	Compact Flash Slot
<i>Manufacturer:</i>	SUMMIT
<i>Product</i>	802.11b/g Compact Flash Radio Module
<i>Model number</i>	SDC-CF10G
<i>Teklogix model number</i>	RA2041
<i>Serial number</i>	N/A
<i>Fcc id</i>	TWG-SDCCF10G
<i>Power</i>	32 mW
<i>Frequency range</i>	2412 to 2472 MHz
<i>Data rates</i>	1, 2, 5.5, 6, 9, 11, 12, 18, 24, 36, 48, 54 MBps
<i>Channels</i>	13 (EU)
<i>L.o. frequencies</i>	2.32 – 2.62 GHz
<i>Ref. Osc. Frequencies</i>	44 MHz, 14.67 MHz
<i>Internal/extrenal antenna</i>	EXTERNAL (Inside the Host)
<i>Rf cable type</i>	50 Ohm coaxial, 1.09 mm Dia
<i>Antenna type + gain</i>	PCB, 0 dBi

**ULTRATECH GROUP OF LABS**3000 Bristol Circle, Oakville, Ontario, Canada L6H 6G4  
Tel. #: 905-829-1570, Fax. #: 905-829-8050, Email: vic@ultratech-labs.com, Website: http://www.ultratech-labs.com**File #: TEK-602-SAR**  
**August 8, 2007**

- Assessed by ITI (UK) Competent Body, NVLAP (USA) Accreditation Body & ACA/AUSTEL (Australia), VCCI (Japan)
- Accredited by Industry Canada (Canada) under ACC-LAB (Europe/Canada MRA and APEC/Canada MRA)
- Recognized/Listed by FCC (USA)
- All test results contained in this engineering test report are traceable to National Institute of Standards and Technology (NIST)

**SPECIFIC ABSORPTION RATE (SAR)**

IEEE C95.1-1991, FCC OET Bulletin 65 (Supplement C), Industry Canada RSS-102(Issue 2) and ACA Radiocommunications (Electromagnetic Radiation – Human Exposure) Amendment Standard 2000 (No. 1)

**WORKABOUT PRO G2 Handheld Computer M/N: 7527C****FCC ID: GM37527CBTRA2041M**

<b>Radio #3 – Bluetooth</b>	
<b>Location</b>	Main Logic Board (Integrated Bluetooth)
<b>Manufacturer:</b>	Askey Computer Corporation
<b>Product</b>	2.4 GHz FHSS Bluetooth
<b>Model number</b>	BTL040
<b>Psion teklogix model number</b>	N/A
<b>Serial number</b>	
<b>Power</b>	<5mW
<b>Frequency range</b>	2402-2480 MHz
<b>Data rates</b>	As per the BT standard
<b>Channels</b>	79
<b>Internal/extrenal antenna</b>	internal

**ULTRATECH GROUP OF LABS**

3000 Bristol Circle, Oakville, Ontario, Canada L6H 6G4

Tel. #: 905-829-1570, Fax. #: 905-829-8050, Email: vic@ultratech-labs.com, Website: http://www.ultratech-labs.com

**File #: TEK-602-SAR****August 8, 2007**

- Assessed by ITI (UK) Competent Body, NVLAP (USA) Accreditation Body & ACA/AUSTEL (Australia), VCCI (Japan)
- Accredited by Industry Canada (Canada) under ACC-LAB (Europe/Canada MRA and APEC/Canada MRA)
- Recognized/Listed by FCC (USA )
- All test results contained in this engineering test report are traceable to National Institute of Standards and Technology (NIST)

## **EXHIBIT 2. COLOCATION RFID WITH 802.11B/G WIRELESS LAN AND BLUETOOTH**

### **2.1. APPLICABILITY & SUMMARY OF SAR RESULTS**

Co-location of RFID with 802.11b/g Wireless LAN(M/N: RA2041) and Bluetooth(M/N: BTL040) in the 7527C had been addressed in this test report.

Since RFID operates at the different frequency range from Wireless LAN and Bluetooth, SAR evaluation were performed independently for each frequency using appropriate probe calibration and tissue dielectric parameter.

SAR evaluation detail of individual radios had been described in the enclosed test reports of

- a) ‘GM37527CBTMPR6XXX-SAR.pdf’ for RFID,
- b) ‘GM37527CBTMPR6XXX-SAR\_CoLoc.pdf’ for Bluetooth, and
- c) ‘GM37527RA2041-SAR\_#.pdf’ for Wireless LAN respectively.

Three radio modules are relatively deployed and located in the host computer (M/N: 7527C) as depicted in the following diagram.

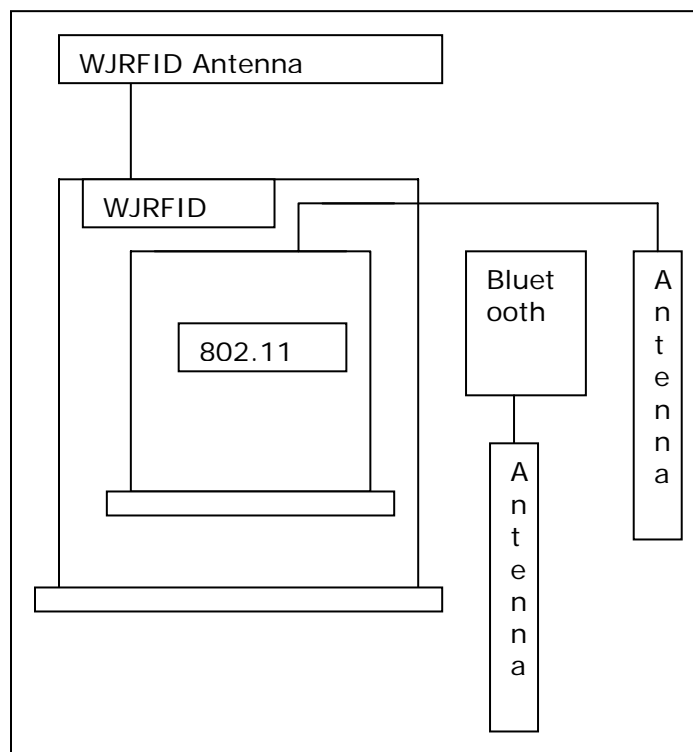

Summary of SAR measurement results excerpted from the corresponding test reports for RFID, Bluetooth and Wireless LAN are listed in the following sections.

### **ULTRATECH GROUP OF LABS**

3000 Bristol Circle, Oakville, Ontario, Canada L6H 6G4  
 Tel. #: 905-829-1570, Fax. #: 905-829-8050, Email: vic@ultratech-labs.com, Website: http://www.ultratech-labs.com

**File #: TEK-602-SAR**  
**August 8, 2007**

- Assessed by ITI (UK) Competent Body, NVLAP (USA) Accreditation Body & ACA/AUSTEL (Australia), VCCI (Japan)
- Accredited by Industry Canada (Canada) under ACC-LAB (Europe/Canada MRA and APEC/Canada MRA)
- Recognized/Listed by FCC (USA)
- All test results contained in this engineering test report are traceable to National Institute of Standards and Technology (NIST)

**2.1.1. Summary of Peak Spatial-Average SAR in the Body Configuration**

**2.1.1.1. Summary of Peak Spatial-Average SAR in the Body Configuration for RFID**

#	Configuration	Antenna Position	Frequency [MHz]	Channel	SAR <sub>local</sub> Before [W/Kg]	SAR <sub>local</sub> After [W/Kg]	MAX SAR <sub>1g</sub> [W/Kg]
* General Population/Uncontrolled Exposure Category Limit							1.6
01	Top of DUT perpendicular to the phantom with spacing of 15 mm	Integrated	902.75	Low			-
02		Integrated	915.25	Middle	0.53	0.51	0.54
03		Integrated	927.25	High			-
04	Front side of DUT in parallel to the phantom with spacing of 15 mm	Integrated	902.75	Low			-
05		Integrated	915.25	Middle	0.38	0.37	0.36
06		Integrated	927.25	High			-
07	Back side of DUT in parallel to the phantom and belt-clip in contact	Integrated	902.75	Low			-
08		Integrated	915.25	Middle	0.00	0.00	< 0.01
09		Integrated	927.25	High			-
10	Left side of DUT in parallel to the phantom with spacing of 15 mm	Integrated	902.75	Low			-
11		Integrated	915.25	Middle	0.02	0.01	0.10
12		Integrated	927.25	High			-
13	Right side of DUT in parallel to the phantom with spacing of 15 mm	Integrated	902.75	Low			-
14		Integrated	915.25	Middle	0.03	0.03	0.10
15		Integrated	927.25	High			-

**2.1.1.2. Summary of Peak Spatial-Average SAR in the Body Configuration for Bluetooth**

#	Configuration	Antenna Position	Frequency [MHz]	Channel	SAR <sub>local</sub> Before [W/Kg]	SAR <sub>local</sub> After [W/Kg]	MAX SAR <sub>1g</sub> [W/Kg]
* General Population/Uncontrolled Exposure Category Limit							1.6
01	Top of DUT perpendicular to the phantom with spacing of 15 mm	Integrated	2402	00			-
02		Integrated	2441	39	0.00	0.00	Less than 0.01
03		Integrated	2480	78			-

**ULTRATECH GROUP OF LABS**

3000 Bristol Circle, Oakville, Ontario, Canada L6H 6G4  
 Tel. #: 905-829-1570, Fax. #: 905-829-8050, Email: vic@ultratech-labs.com, Website: http://www.ultratech-labs.com

File #: **TEK-602-SAR**  
 August 8, 2007

- Assessed by ITI (UK) Competent Body, NVLAP (USA) Accreditation Body & ACA/AUSTEL (Australia), VCCI (Japan)
- Accredited by Industry Canada (Canada) under ACC-LAB (Europe/Canada MRA and APEC/Canada MRA)
- Recognized/Listed by FCC (USA)
- All test results contained in this engineering test report are traceable to National Institute of Standards and Technology (NIST)

**2.1.1.3. Summary of Peak Spatial-Average SAR in the Body Configuration for 802.11b/g Wireless LAN**

**2.1.1.3.1. Keypad Up With 1.5 cm Gap**

Model	Mode	Accessory	Ch an.	Freq(MHz)	Modulation Type	Conducted Power (dBm)	Power Drift (dB)	Measured 1g SAR (W/Kg)	Limit (W/Kg)	Results	
7527C	802.11b	Endcap 1+B2	1	2412(Low)	CCK	20.65	0.177	0.011	1.6	Pass	
			6	2437(Mid)	CCK	20.32	0.171	0.011	1.6	Pass	
			11	2462(High)	CCK	20.40	-0.175	0.00986	1.6	Pass	
	802.11b	With BT On	Endcap 1+B2	<b>6</b>	<b>2437(Mid)</b>	<b>CCK</b>	<b>20.32</b>	<b>-0.171</b>	<b>0.012</b>	<b>1.6</b>	<b>Pass</b>
	802.11g	Endcap 1+B2	1	2412(Low)	OFDM	22.98	-	-	-	-	-
			6	2437(Mid)	OFDM	22.07	0.174	0.0067	1.6	Pass	
11			2462(High)	OFDM	22.11	-	-	-	-	-	
7527C	802.11b	Endcap 1+B2	6	2437(Mid)	CCK	20.32	0.148	0.014	1.6	Pass	
	802.11b	With BT On	Endcap 1+B2	<b>6</b>	<b>2437(Mid)</b>	<b>CCK</b>	<b>20.32</b>	<b>0.106</b>	<b>0.014</b>	<b>1.6</b>	<b>Pass</b>

**2.1.1.3.2. Keypad Down With 1.5 cm Gap**

Model	Mode	Accessory	Ch an.	Freq(MHz)	Modulation Type	Conducted Power (dBm)	Power Drift (dB)	Measured 1g SAR (W/Kg)	Limit (W/Kg)	Results	
7527C	802.11b	Endcap 1+B2	1	2412(Low)	CCK	20.65	-	-	-	-	
			6	2437(Mid)	CCK	20.32	-0.116	0.011	1.6	Pass	
			11	2462(High)	CCK	20.40	-	-	-	-	-
	802.11g	Endcap 1+B2	1	2412(Low)	OFDM	22.98	-	-	-	-	-
			6	2437(Mid)	OFDM	22.07	-	-	-	-	-
			11	2462(High)	OFDM	22.11	-	-	-	-	-

- Assessed by ITI (UK) Competent Body, NVLAP (USA) Accreditation Body & ACA/AUSTEL (Australia), VCCI (Japan)
- Accredited by Industry Canada (Canada) under ACC-LAB (Europe/Canada MRA and APEC/Canada MRA)
- Recognized/Listed by FCC (USA)
- All test results contained in this engineering test report are traceable to National Institute of Standards and Technology (NIST)



**SPECIFIC ABSORPTION RATE (SAR)**

IEEE C95.1-1991, FCC OET Bulletin 65 (Supplement C), Industry Canada RSS-102(Issue 2) and ACA Radiocommunications (Electromagnetic Radiation – Human Exposure) Amendment Standard 2000 (No. 1)

**WORKABOUT PRO G2 Handheld Computer M/N: 7527C****FCC ID: GM37527CBTRA2041M****2.1.1.3.3. Holster Left Side Touch**

Model	Mode	Accessory	Chan.	Freq(MHz)	Modulation Type	Conducted Power (dBm)	Power Drift (dB)	Measured 1g SAR (W/Kg)	Limit (W/Kg)	Results
7527C	802.11b	Endcap 1+B2	1	2412(Low)	CCK	20.65	-0.004	0.15	1.6	Pass
			6	2437(Mid)	CCK	20.32	-0.168	0.154	1.6	Pass
			11	2462(High)	CCK	20.40	-0.089	0.154	1.6	Pass
		Endcap 1+B2	6	2437(Mid)	CCK	20.32	-0.165	0.198	1.6	Pass
		Endcap 1+B2	6	2437(Mid)	CCK	20.32	0.127	0.162	1.6	Pass
		Endcap 1+B2	<b>1</b>	<b>2412(Low)</b>	<b>CCK</b>	<b>20.65</b>	<b>-0.192</b>	<b>0.23</b>	<b>1.6</b>	<b>Pass</b>
			6	2437(Mid)	CCK	20.32	-0.12	0.216	1.6	Pass
			11	2462(High)	CCK	20.40	-0.062	0.157	1.6	Pass
		Endcap 1+B2	6	2437(Mid)	CCK	20.32	0.114	0.197	1.6	Pass
		POD 1 + B2	6	2437(Mid)	CCK	20.32	-0.106	0.132	1.6	Pass
		POD 2 + B2	6	2437(Mid)	CCK	20.32	-0.014	0.159	1.6	Pass
		POD 3 + B2	6	2437(Mid)	CCK	20.32	-0.149	0.152	1.6	Pass
	POD 4 + B2	6	2437(Mid)	CCK	20.32	0.116	0.138	1.6	Pass	
POD 6 + B2	6	2437(Mid)	CCK	20.32	0.022	0.172	1.6	Pass		
802.11b With BT On	Endcap 1+B2	6	2437(Mid)	CCK	20.32	-0.087	0.161	1.6	Pass	
802.11g	Endcap 1+B2	6	2437(Mid)	OFDM	22.07	-0.125	0.024	1.6	Pass	
7527C	802.11b	Endcap 6+B2	<b>1</b>	<b>2412(Low)</b>	<b>CCK</b>	<b>20.65</b>	<b>-0.147</b>	<b>0.234</b>	<b>1.6</b>	<b>Pass</b>

**2.1.1.3.4. Holster Right Side Touch**

Model	Mode	Accessory	Chan.	Freq(MHz)	Modulation Type	Conducted Power (dBm)	Power Drift (dB)	Measured 1g SAR (W/Kg)	Limit (W/Kg)	Results
7527C	802.11b	Endcap 1+B2	1	2412(Low)	CCK	20.65	-0.103	0.01	1.6	Pass
			6	2437(Mid)	CCK	20.32	0.107	0.012	1.6	Pass

**ULTRATECH GROUP OF LABS**3000 Bristol Circle, Oakville, Ontario, Canada L6H 6G4  
Tel. #: 905-829-1570, Fax. #: 905-829-8050, Email: vic@ultratech-labs.com, Website: http://www.ultratech-labs.comFile #: **TEK-602-SAR**  
August 8, 2007

- Assessed by ITI (UK) Competent Body, NVLAP (USA) Accreditation Body & ACA/AUSTEL (Australia), VCCI (Japan)
- Accredited by Industry Canada (Canada) under ACC-LAB (Europe/Canada MRA and APEC/Canada MRA)
- Recognized/Listed by FCC (USA)
- All test results contained in this engineering test report are traceable to National Institute of Standards and Technology (NIST)

**SPECIFIC ABSORPTION RATE (SAR)**

IEEE C95.1-1991, FCC OET Bulletin 65 (Supplement C), Industry Canada RSS-102(Issue 2) and ACA Radiocommunications (Electromagnetic Radiation – Human Exposure) Amendment Standard 2000 (No. 1)

**WORKABOUT PRO G2 Handheld Computer M/N: 7527C****FCC ID: GM37527CBTRA2041M****2.1.2. Maximum Peak Spatial-Average SAR in the Body Configuration****2.1.2.1. Maximum Peak Spatial-Average SAR in the Body Configuration for RFID**

#	Configuration	Device Test Positions	Antenna Position	Freq. [MHz]	Channel	MAX. SAR <sub>1g</sub> [W/Kg]
*	General Population/Uncontrolled Exposure Category Limit					1.6
02	Top of DUT perpendicular to the phantom with spacing of 15 mm	Body	Integrated	915.25	Middle	0.54

**2.1.2.2. Maximum Peak Spatial-Average SAR in the Body Configuration for Bluetooth**

#	Configuration	Device Test Positions	Antenna Position	Freq. [MHz]	Channel	MAX. SAR <sub>1g</sub> [W/Kg]
*	General Population/Uncontrolled Exposure Category Limit					1.6
02	Top of DUT perpendicular to the phantom with spacing of 15 mm	Body	Integrated	2441	39	< 0.01

**2.1.2.3. Maximum Peak Spatial-Average SAR in the Body Configuration for 802.11b/g Wireless LAN****2.1.2.3.1. Holster Left Side Touch**

Model	Mode	Accessory	Chan.	Freq(MHz)	Modulation Type	Conducted Power (dBm)	Power Drift (dB)	Measured 1g SAR (W/Kg)	Limit (W/Kg)	Results
7527C	802.11b	Endcap 6+B2	1	2412(Low)	CCK	20.65	-0.147	0.234	1.6	Pass

**ULTRATECH GROUP OF LABS**3000 Bristol Circle, Oakville, Ontario, Canada L6H 6G4  
Tel. #: 905-829-1570, Fax. #: 905-829-8050, Email: vic@ultratech-labs.com, Website: http://www.ultratech-labs.comFile #: TEK-602-SAR  
August 8, 2007

- Assessed by ITI (UK) Competent Body, NVLAP (USA) Accreditation Body & ACA/AUSTEL (Australia), VCCI (Japan)
- Accredited by Industry Canada (Canada) under ACC-LAB (Europe/Canada MRA and APEC/Canada MRA)
- Recognized/Listed by FCC (USA)
- All test results contained in this engineering test report are traceable to National Institute of Standards and Technology (NIST)

**2.1.3. Maximum Peak Spatial-Average SAR for Co-location RFID, Bluetooth and 802.11b/g Wireless LAN**

The worst case maximum peak spatial-average SAR measurement result for each radio configuration was summed to verify and confirm the compliance of RF exposure safety requirement.

$$\begin{aligned}
 & \text{(Maximum Peak Spatial-Average SAR for RFID)} \\
 & + \text{(Maximum Peak Spatial-Average SAR for Bluetooth)} \\
 & + \text{(Maximum Peak Spatial-Average SAR for 802.11b/g Wireless LAN)} \\
 & = 0.54 + (\text{less than } 0.01) + 0.234 = (\text{less than } 0.774)
 \end{aligned}$$

The maximum peak spatial - average SAR measured was found to be less than 0.774 W/Kg.

Exposure Category and SAR Limits	Test Requirements	Compliance (Yes/No)
<p><b>General population/Uncontrolled exposure</b>                      0.08W/kg whole body average and <b>spatial peak SAR of 1.6W/kg</b>, averaged over 1gram of tissue                      Hands, wrist, feet and ankles have a peak SAR not to exceed 4 W/kg, averaged over 10 grams of tissue.</p>	<p>Requirements using guidelines established in IEEE C95.1-1991</p> <p>FCC OET Bulletin 65 (Supplement C Edition 01-01)</p> <p>Industry Canada RSS-102 (Issue 2).</p> <p>ACA Radiocommunications (Electromagnetic Radiation – Human Exposure) Amendment Standard 2000 (No. 1)</p>	<p>YES</p>
<p><b>Occupational/Controlled Exposure</b>                      0.4W/kg whole body average and <b>spatial peak SAR of 8W/kg</b>, averaged over 1gram of tissue                      Hands, wrist, feet and ankles have a peak SAR not to exceed 20 W/kg, averaged over 10 grams of tissue.</p>	<p>Requirements using guidelines established in IEEE C95.1-1991</p> <p>FCC OET Bulletin 65 (Supplement C Edition 01-01),</p> <p>Industry Canada RSS-102 (Issue 2)</p> <p>ACA Radiocommunications (Electromagnetic Radiation – Human Exposure) Amendment Standard 2000 (No. 1)</p>	<p>N/A</p>

- Assessed by ITI (UK) Competent Body, NVLAP (USA) Accreditation Body & ACA/AUSTEL (Australia), VCCI (Japan)
- Accredited by Industry Canada (Canada) under ACC-LAB (Europe/Canada MRA and APEC/Canada MRA)
- Recognized/Listed by FCC (USA)
- All test results contained in this engineering test report are traceable to National Institute of Standards and Technology (NIST)

## **2.2. SAR MEASUREMENT UNCERTAINTY**

Please refer to each enclosed SAR test report for the uncertainty analysis of the corresponding radio module respectively for detail.

---

### **ULTRATECH GROUP OF LABS**

3000 Bristol Circle, Oakville, Ontario, Canada L6H 6G4  
Tel. #: 905-829-1570, Fax. #: 905-829-8050, Email: vic@ultratech-labs.com, Website: <http://www.ultratech-labs.com>

**File #: TEK-602-SAR**  
**August 8, 2007**

- Assessed by ITI (UK) Competent Body, NVLAP (USA) Accreditation Body & ACA/AUSTEL (Australia), VCCI (Japan)
- Accredited by Industry Canada (Canada) under ACC-LAB (Europe/Canada MRA and APEC/Canada MRA)
- Recognized/Listed by FCC (USA)
- *All test results contained in this engineering test report are traceable to National Institute of Standards and Technology (NIST)*