



FCC/IC TEST REPORT

for

47 CFR Part 22H, 24E, RSS-132, and RSS-133

Equipment : Hand-held Micro-computer
Trade Name : WORKABOUT PRO
Model No. : RA3030-G2
FCC ID : GM375273RADA
IC ID : 2739D-7527RADA
Tx Frequency Range : GSM850 : 824~849 MHz
PCS1900 : 1850~1910 MHz
Max. ERP/EIRP Power : GSM850(GSM) : 0.45 W for 7527C
0.47 W for 7527S
GSM850(EDGE) : 0.07 W for 7527C
0.06 W for 7527S
PCS1900(GSM) : 1.38 W for 7527C
0.98 W for 7527S
PCS1900(EDGE) : 0.19 W for 7527C
0.12 W for 7527S
Emission Designator : GSM : 300KGXW
EDGE : 300KG7W
Application Type : PC II Chage
Applicant : Psion Teklogix Inc.
2100 Meadowvale Blvd., Mississauga, Ontario, L5N 7J9,
Canada

- The test result refers exclusively to the test presented test model / sample.
- Without written approval of SPORTON International Inc., the test report shall not be reproduced except in full.
- **Certificate or Test Report must not be used by the applicant to claim the product in this test report endorsement by NVLAP or any agency of U.S. government.**
- The data shown in this test report were carried out on May 08, 2007 at **Sporton International Inc. LAB.**
- Report No.: FG710211-B, Report Version: Rev. 03.

Roy Wu
Deputy Manager

SPORTON International Inc.

6F, No.106, Sec. 1, Hsin Tai Wu Rd., Hsi Chih, Taipei Hsien, Taiwan, R.O.C.

SPORTON International Inc.

TEL : 886-2-2696-2468

FAX : 886-2-2696-2255

Report Version: Rev. 03



Table of Contents

History of this test report.....ii

1. General Information 1

 1.1. Applicant1

 1.2. Manufacturer1

 1.3. Basic Description of Equipment under Test.....1

 1.4. Details of the Accessory.....2

 1.5. Feature of Equipment under Test3

 1.6. Report Date.....4

2 Test Configuration of Equipment under Test5

 2.1 Test Manner5

 2.2 Test Mode6

 2.3 Connection Diagram of Test System7

 2.4 Ancillary Equipment List.....7

3. General Information of Test Site8

 3.1 Test Voltage8

 3.2 Test in Compliance with8

 3.3 Frequency Range Investigated8

 3.4 Test Distance8

4. Test Data and Test Result.....9

 4.1 List of Measurements and Examinations9

 4.2 RF Output Power10

 4.3 ERP / EIRP Measurement11

 4.4 Occupied Bandwidth and Band Edge Measurement29

 4.5 Conducted Emission56

 4.6 Field Strength of Spurious Radiation75

 4.7 Frequency Stability (Temperature Variation)297

 4.8 Frequency Stability (Voltage Variation).....300

5 List of Measurement Equipments302

6 Uncertainty Evaluation.....303

Appendix A - External Photographs

Appendix B - Internal Photographs

Appendix C - Setup Photographs



History of this test report

Report Issue Date: May 14, 2007

Report No.	Description



1. General Information

1.1. Applicant

Psion Teklogix Inc.

2100 Meadowvale Blvd., Mississauga, Ontario, L5N 7J9, Canada

1.2 Manufacturer

ASKEY COMPUTER CORP.

10F, No. 119, Chienkang Rd., Chung-Ho, Taipei, Taiwan, R.O.C.

1.3 Basic Description of Equipment under Test

Equipment : Hand-held Micro-computer
Trade Name : WORKABOUT PRO
Model No. : RA3030-G2
FCC ID : GM375273RADA
IC ID : 2739D-7527RADA
Power Supply Type : Switching
AC Power Cord : AC 120V, Wall-mount, 2 pin

Remark:

1. The host 7527S is the shorter version of model 7527C. They have the same module and antenna. The only difference between the two models is the keypad.



1.4 Details of the Accessory

Terminal Options				
		Model Number	Part Number	Remark
GSM	Quad-band MC75 GSM Radio with Stubby antenna	RA3030-G2	N/A	
Kit	Blackroc Endcap Kit 3-Port (RS232,TTL,IRDA); kit	BR1000-G1	1050812	Endcap 7
802.11g	802.11g CF Radio	RA2041	N/A	
Endcap with GSM	Imager, 2D HHP 5180 Endcap with GSM antenna	WA8110-G1	1050830	Endcap 5
	Imager, 1D EV15 Endcap, with GSM antenna	WA9113-G1	1050778	Endcap 1
	Scanner, 1D SE955 Endcap, with GSM antenna	WA9112-G1	1050491	Endcap 2
Endcap	Imager, 2D HHP 5180 Endcap	WA8010-G1	1050890	Endcap 6
	Imager, 1D Intermec EV15 Endcap	WA9103-G1	1050777	Endcap 3
	Scanner, 1D SE955 Endcap	WA9102-G1	1050492	Endcap 4
POD	Imager, 1D Intermec EV15 Pod	WA9003-G1	1050462	POD 1
	Scanner, 1D SE955 Pod	WA9002-G1	1050230	POD 2
	Scanner, 1D SE1223HP Pod	WA9000-G1	1050229	POD 3
	Scanner, 1D SE1223LR Pod	WA9005-G1	1051025	POD 4
	Imager, 2D HHP 5180 Pod	WA9012-G1	1050865	POD 6

Docks and Connectivity Options				
Docking	Desktop Docking Station	WA4003-G2	1050955	Docking 1
	USB Cable	N/A	N/A	USB 1
	Vehicle Cradle - Powered 12V with Port Replicator	WA4005-G1 (port replicator)	1080224 (port replicator)	
	Cigarette light adaptor	WA3113-G2	1050463-001	
	Standalone Power Supply	PS1050-G1	1050465	
USB	USB to Ethernet adaptor module	WA4010-G1	1050236	USB 2
	USB to RS232 adaptor module	WA4015-G1	1050067-300	USB 3
Tether	Tether to Ethernet adaptor module	WA4025	1050255	USB 5
	Tether adaptor cable (for connecting keyboards)	WA1001	1050551	USB 4

Others				
Battery	3000mAh	WA3006		B2
	4000mAh	WA3010	1050192	B3
Holster	Soft Shell Holster	WA6050	1030227	C1
Pistol Grips	Pistol Grip Symbol SE1223 Scanner	WA6001-G1	1050460	C2

Remark:

1. USB Cable comes in the box as part of the Docking StationWA4003-G2.
2. Desktop Docking system is only used to battery charging.
3. The Endcap and POD use different type of scanner and imager components inside, please find the clause 7.3 of user manual.



1.5 Feature of Equipment under Test

GSM module

Product Feature & Specification	
1. Model Name :	RA3030-G2
2. FCC ID :	GM375273RADA
3. IC ID :	2739D-7527RADA
4. Tx Frequency :	GSM850 : 824 ~ 849 MHz PCS1900 : 1850 ~1910 MHz
5. Rx Frequency :	GSM850 : 869 ~ 894 MHz PCS1900 : 1930 ~ 1990 MHz
6. Maximum Output Power to Antenna :	GSM : 31.54 dBm(GSM) ; 23.10 dBm(EDGE) PCS : 29.03 dBm(GSM) ; 22.00 dBm(EDGE)
7. Maximum ERP/EIRP :	GSM850(GSM) : 0.45 W (26.53 dBm) for 7527C 0.47 W (26.73 dBm) for 7527S GSM850(EDGE) : 0.07 W (18.17 dBm) for 7527C 0.06 W (17.85 dBm) for 7527S PCS1900(GSM) : 1.38 W (31.39 dBm) for 7527C 0.98 W (29.92 dBm) for 7527S PCS1900(EDGE) : 0.19 W (22.84 dBm) for 7527C 0.12 W (20.85 dBm) for 7527S
8. Antenna Type :	PCB Antenna
9. Power Rating (DC/AC , Voltage and Current of RF element or PA) :	DC 3.8V / 810 mA
10. Digital Modulation Emission :	GSM : GMSK EDGE : 8PSK
11. Type of Emission :	GSM : 300KGXW EDGE : 300KG7W
12. Device Power Class :	GSM850 : 4 PCS1900 : 1

Co-transmission BT Module

Product Feature & Specification			
1. Model Name	BTL040		
2. FCC ID	GM37525BTB		
3. IC ID	2739D-7525BTB		
4. Modulation Type/Data Rate	GFSK		
5. Frequency Range.	2400 MHz ~ 2483.5 MHz		
6. Number of Channels	79		
7. Carrier Frequency of each channel	2402+ n*1 MHz, n= 0~78		
8. Channel Spacing	1 MHz		
9. Maximum Output Power to Antenna (Normal condition)	0.59 dBm		
10. Type of Antenna Connector	N/A		
11. Antenna Type	Chip Antenna		
12. Antenna Gain	4.1 dBi		
13. Function Type	Transmitter	Transceiver	V
14. Power Rating (DC/AC , Voltage)	AC100~240V		



Co-transmission WLAN Module

Product Feature & Specification	
1. Model Name	RA2041
2. FCC ID	GM37527RA2041
3. IC ID	2739D-BGRADA
4. Modulation Type/Data Rate	DSSS / OFDM
5. Frequency Range.	2400 MHz ~ 2483.5 MHz
6. Number of Channels	11
7. Carrier Frequency of each channel	2412+(n-1)*5 MHz; n=1~11
8. Maximum Output Power to Antenna (Normal condition)	802.11b : 20.65 dBm 802.11g : 22.98 dBm
9. Type of Antenna Connector	N/A
10. Antenna Type	PCB Antenna
11. Antenna Gain	-2.66 dBi (7527C) -2.48 dBi (7527S)
12. Function Type	Transmitter Transceiver V
13. Power Rating (DC/AC , Voltage)	AC100~240V

Host

Product Feature & Specification	
1. Equipment	Hand-held Micro-computer
2. Trade Name	WORKABOUT PRO
3. Model Name	7527C / 7527S Series
4. HW Version	7527C : ES3 7527S : ES2
5. SW Version	A
6. Battery	WA3006

1.6 Report Date

EUT Received : Jan. 02, 2007

Report Date : May 14, 2007



2 Test Configuration of Equipment under Test

2.1 Test Manner

- a. The spurious emission measurements were carried out in semi-anechoic chamber with 3-meter test range.
- b. During all testings, EUT is in link mode with base station emulator at maximum power level.
- c. Frequency range investigated: radiated emission 30 MHz to 9000 MHz for GSM850; 30MHz to 19000 MHz for PCS.



2.2 Test Mode

Application	GSM850	PCS1900
Radiated Emission	<input checked="" type="checkbox"/> Mode 1: GSM Link for 7527C <input checked="" type="checkbox"/> Mode 2: EDGE Link for 7527C <input checked="" type="checkbox"/> Mode 5: GSM Link for 7527S <input checked="" type="checkbox"/> Mode 6: EDGE Link for 7527S <input checked="" type="checkbox"/> Mode 9: GSM Link Mode + BT Link + WLAN Link for 7527C <input checked="" type="checkbox"/> Mode 10: GSM Link + Endcap 1 for 7527C <input checked="" type="checkbox"/> Mode 11: GSM Link + Endcap 2 for 7527C <input checked="" type="checkbox"/> Mode 12: GSM Link + Endcap 5 + for 7527C <input checked="" type="checkbox"/> Mode 13: GSM Link + POD 1 for 7527C <input checked="" type="checkbox"/> Mode 14: GSM Link + POD 2 for 7527C <input checked="" type="checkbox"/> Mode 15: GSM Link + POD 3 for 7527C <input checked="" type="checkbox"/> Mode 16: GSM Link + POD 4 for 7527C <input checked="" type="checkbox"/> Mode 17: GSM Link + POD 6 for 7527C <input checked="" type="checkbox"/> Mode 18: EDGE Link + Endcap 5 for 7527C <input checked="" type="checkbox"/> Mode 19: GSM Link + Endcap 5 + Pistol Grips for 7527C <input checked="" type="checkbox"/> Mode 30: GSM Link + Endcap 5 for 7527S	<input checked="" type="checkbox"/> Mode 3: GSM Link for 7527C <input checked="" type="checkbox"/> Mode 4: EDGE Link for 7527C <input checked="" type="checkbox"/> Mode 7: GSM Link for 7527S <input checked="" type="checkbox"/> Mode 8: EDGE Link for 7527S <input checked="" type="checkbox"/> Mode 20: GSM Link + Endcap 1 for 7527C <input checked="" type="checkbox"/> Mode 21: GSM Link + Endcap 2 for 7527C <input checked="" type="checkbox"/> Mode 22: GSM Link + Endcap 5 + for 7527C <input checked="" type="checkbox"/> Mode 23: GSM Link + POD 1 for 7527C <input checked="" type="checkbox"/> Mode 24: GSM Link + POD 2 for 7527C <input checked="" type="checkbox"/> Mode 25: GSM Link + POD 3 for 7527C <input checked="" type="checkbox"/> Mode 26: GSM Link + POD 4 for 7527C <input checked="" type="checkbox"/> Mode 27: GSM Link + POD 6 for 7527C <input checked="" type="checkbox"/> Mode 28: EDGE Link + Endcap 2 for 7527C <input checked="" type="checkbox"/> Mode 29: GSM Link + Endcap 2 + Pistol Grips for 7527C <input checked="" type="checkbox"/> Mode 31: GSM Link + Endcap 2 for 7527S
Conducted Measurement	<input checked="" type="checkbox"/> Mode 1: GSM_CH 189 <input checked="" type="checkbox"/> Mode 2: EDGE_CH 189	<input checked="" type="checkbox"/> Mode 3: GSM_CH 661 <input checked="" type="checkbox"/> Mode 4: EDGE_CH 661

Remark:

1. We chose the worst case mode from test mode 1 through 8 for co-location, test mode 9, the radiated emission testing for GSM, Bluetooth, and WLAN co-transmission on the Host 7527C.
2. Then performed new additional tests using different accessories, Endcap and POD, against 7527C in test mode 10 to 17 for GSM 850 system and test mode 20 to 27 for GSM 1900 system, then chose the worst case for EDGE mode and Pistol Grips ,test mode 18,19 and 28,29 .
3. Finally, we performed test mode 30 and 31 against 7527S which is the worst case mode as mentioned above.

2.3 Connection Diagram of Test System

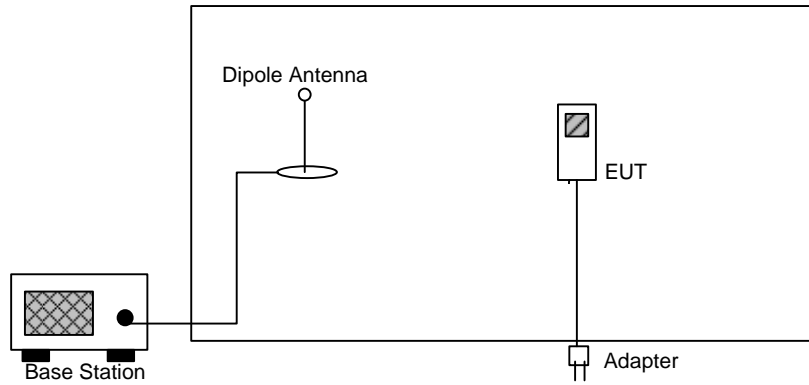

2.4 Ancillary Equipment List

Item	Equipment	Model No.	Serial No.
1.	Base Station(R&S)	CMU200	106656



3. General Information of Test Site

Test Site Location : No. 52, Hwa Ya 1st Rd., Hwa Ya Technology Park,
Kwei-Shan Hsiang, Tao Yuan Hsien, Taiwan, R.O.C.
TEL : 886-3-327-3456
FAX : 886-3-318-0055

Test Site No : 03CH06-HY

The chamber meets the characteristics of ANSI C63.4-2003. This site is on file with the FCC.

3.1 Test Voltage

120V/ 60Hz

3.2 Test in Compliance with

47 CFR Part 22H, 24E, Part 2, IC RSS-132 Issued 2 and RSS-133 Issued 3

3.3 Frequency Range Investigated

- a. Radiation: from 30MHz to 9000MHz for GSM850.
- b. Radiation: from 30 MHz to 19000 MHz for PCS1900.

3.4 Test Distance

The test distance of radiated emission from antenna to EUT is 3 m.



4. Test Data and Test Result

4.1 List of Measurements and Examinations

FCC Rule	IC Rule	DESCRIPTION OF TEST	Result	Section
§2.1046	RSS-132 §4.4 RSS-133 §6.4	RF Output Power	Passed	4.2
§ 22.913 §24.232	RSS-132 §4.4 RSS-133 §6.4	ERP / EIRP	Passed	4.3
§2.1049, § 22.917, § 24.238(b)	RSS-132 §4.5 RSS-133 §6.5	Occupied Bandwidth & Band Edge Measurement	Passed	4.4
§2.1051	RSS-132 §4.5 RSS-133 §6.5	Conducted Emission	Passed	4.5
§2.1053	RSS-132 §4.5 RSS-133 §6.5	Field Strength of Spurious Radiation	Passed	4.6
§2.1055, § 22.355, §24.235	RSS-132 §4.3 RSS-133 §6.3	Frequency Stability vs. Temperature	Passed	4.7
§2.1055, §22.355, §24.235	RSS-132 §4.3 RSS-133 §6.3	Frequency Stability vs. Voltage	Passed	4.8

4.2 RF Output Power

4.2.1 Measurement Instruments :

As described in chapter 5 of this test report.

4.2.2 Test Procedure :

1. The transmitter output was connected to power meter and base station through power divider.
2. Set EUT at PCL=5 for GSM850 and/or PCL=0 for PCS1900 maximum power through base station.
3. Select lowest, middle, and highest channels for each band.

4.2.3 Test Setup Layout :

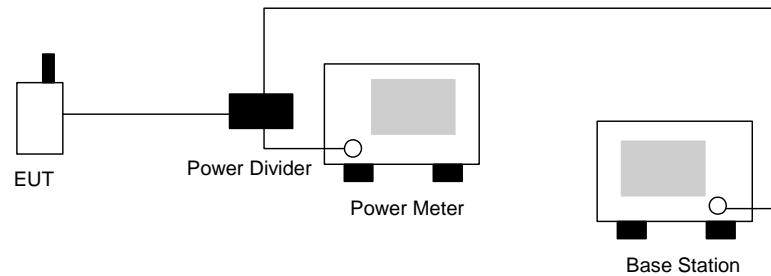

4.2.4 Test Result :

Bands	Channel	Frequency (MHz)	Conducted Power (dBm)	Conducted Power (Watts)
GSM850 (GSM)	128	824.2 (Low)	31.54	1.426
	189	836.4 (Mid)	31.49	1.409
	251	848.8 (High)	31.44	1.393
GSM850 (EDGE)	128	824.2 (Low)	23.10	0.204
	189	836.4 (Mid)	23.10	0.204
	251	848.8 (High)	23.00	0.200
PCS1900 (GSM)	512	1850.2 (Low)	29.03	0.800
	661	1880.0 (Mid)	28.76	0.752
	810	1909.8 (High)	28.41	0.693
PCS1900 (EDGE)	512	1850.2 (Low)	22.00	0.158
	661	1880.0 (Mid)	21.90	0.155
	810	1909.8 (High)	21.70	0.148



4.3 ERP / EIRP Measurement

Equivalent isotropic radiated power measurements by substitution method according to ANSI/TIA/EIA-603-C.

4.3.1 Measurement Instruments

As described in chapter 5 of this test report.

4.3.2 Test Procedure

4. The EUT was placed on a rotatable table with 1.0 meter height in an fully anechoic chamber.
5. The EUT was set 1.2 meters from the receiving antenna which was mounted on the antenna tower.
6. The table was rotated 360 degrees to determine the position of the highest radiated power.
7. The height of the receiving antenna is also kept at 1.0M height.
8. Taking the record of maximum ERP/EIRP.
9. A dipole antenna was substituted in place of the EUT and was driven by a signal generator.
10. The conducted power at the terminal of the dipole antenna is measured.
11. Repeat step 3 to step 5 to get the maximum ERP/EIRP of the substitution antenna.
12. $ERP/EIRP = P_s + E_t - E_s + G_s = P_s + R_t - R_s + G_s$

P_s (dBm) : Input power to substitution antenna.

G_s (dBi or dBd) : Substitution antenna Gain.

$E_t = R_t + AF$

$E_s = R_s + AF$

AF (dB/m) : Receive antenna factor

R_t : The highest received signal in Spectrum Analyzer for EUT.

R_s : The highest received signal in spectrum analyzer for substitution antenna.

4.3.3 Test Setup Layout of ERP/EIRP

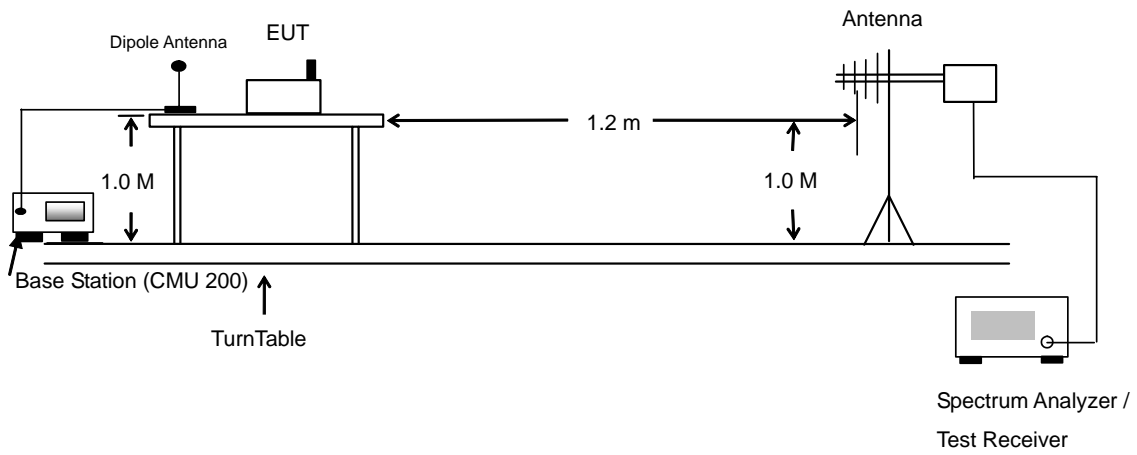



4.3.4 Test Result

GSM850 (GSM) Radiated Power ERP for 7527C						
Horizontal Polarization						
Frequency (MHz)	Rt (dBm)	Rs (dBm)	Ps (dBm)	Gs (dBd)	ERP (dBm)	ERP (W)
824.20	-22.90	-48.12	0.00	-1.08	24.14	0.26
836.40	-22.44	-48.28	0.00	-0.93	24.91	0.31
848.80	-21.58	-48.35	0.00	-0.76	26.01	0.40
Vertical Polarization						
Frequency (MHz)	Rt (dBm)	Rs (dBm)	Ps (dBm)	Gs (dBd)	ERP (dBm)	ERP (W)
824.20	-23.06	-47.97	0.00	-1.08	23.83	0.24
836.40	-22.97	-48.01	0.00	-0.93	24.11	0.26
848.80	-22.45	-48.05	0.00	-0.76	24.84	0.30

GSM850 (GSM) Radiated Power ERP for 7527S						
Horizontal Polarization						
Frequency (MHz)	Rt (dBm)	Rs (dBm)	Ps (dBm)	Gs (dBd)	ERP (dBm)	ERP (W)
824.20	-22.90	-48.12	0.00	-1.08	24.14	0.26
836.40	-22.12	-48.28	0.00	-0.93	25.23	0.33
848.80	-21.10	-48.35	0.00	-0.76	26.49	0.45
Vertical Polarization						
Frequency (MHz)	Rt (dBm)	Rs (dBm)	Ps (dBm)	Gs (dBd)	ERP (dBm)	ERP (W)
824.20	-23.06	-47.97	0.00	-1.08	23.83	0.24
836.40	-21.17	-48.01	0.00	-0.93	25.91	0.39
848.80	-20.58	-48.05	0.00	-0.76	26.71	0.47



GSM850 (EDGE) Radiated Power ERP for 7527C						
Horizontal Polarization						
Frequency (MHz)	Rt (dBm)	Rs (dBm)	Ps (dBm)	Gs (dBd)	ERP (dBm)	ERP (W)
824.20	-29.97	-48.12	0.00	-1.08	17.07	0.05
836.40	-30.00	-48.28	0.00	-0.93	17.35	0.05
848.80	-30.27	-48.35	0.00	-0.76	17.32	0.05
Vertical Polarization						
Frequency (MHz)	Rt (dBm)	Rs (dBm)	Ps (dBm)	Gs (dBd)	ERP (dBm)	ERP (W)
824.20	-29.55	-47.97	0.00	-1.08	17.34	0.05
836.40	-29.14	-48.01	0.00	-0.93	17.94	0.06
848.80	-29.12	-48.05	0.00	-0.76	18.17	0.07

GSM850 (EDGE) Radiated Power ERP for 7527S						
Horizontal Polarization						
Frequency (MHz)	Rt (dBm)	Rs (dBm)	Ps (dBm)	Gs (dBd)	ERP (dBm)	ERP (W)
824.20	-29.74	-48.12	0.00	-1.08	17.30	0.05
836.40	-29.56	-48.28	0.00	-0.93	17.79	0.06
848.80	-29.74	-48.35	0.00	-0.76	17.85	0.06
Vertical Polarization						
Frequency (MHz)	Rt (dBm)	Rs (dBm)	Ps (dBm)	Gs (dBd)	ERP (dBm)	ERP (W)
824.20	-31.68	-47.97	0.00	-1.08	15.21	0.03
836.40	-31.00	-48.01	0.00	-0.93	16.08	0.04
848.80	-30.75	-48.05	0.00	-0.76	16.54	0.05

**PCS1900 (GSM) Radiated Power EIRP for 7527C**

Horizontal Polarization

Frequency (MHz)	Rt (dBm)	Rs (dBm)	Ps (dBm)	Gs (dBi)	EIRP (dBm)	EIRP (W)
1850.20	-26.29	-51.88	0.00	1.96	27.55	0.57
1880.00	-27.42	-52.99	0.00	2.00	27.57	0.57
1909.80	-30.07	-54.28	0.00	1.98	26.19	0.42

Vertical Polarization

Frequency (MHz)	Rt (dBm)	Rs (dBm)	Ps (dBm)	Gs (dBi)	EIRP (dBm)	EIRP (W)
1850.20	-22.98	-52.13	0.00	1.96	31.11	1.29
1880.00	-23.78	-53.17	0.00	2.00	31.39	1.38
1909.80	-25.64	-54.13	0.00	1.98	30.47	1.11

PCS1900 (GSM) Radiated Power EIRP for 7527S

Horizontal Polarization

Frequency (MHz)	Rt (dBm)	Rs (dBm)	Ps (dBm)	Gs (dBi)	EIRP (dBm)	EIRP (W)
1850.20	-25.05	-51.88	0.00	1.96	28.79	0.76
1880.00	-25.96	-52.99	0.00	2.00	29.03	0.80
1909.80	-27.88	-54.28	0.00	1.98	28.38	0.69

Vertical Polarization

Frequency (MHz)	Rt (dBm)	Rs (dBm)	Ps (dBm)	Gs (dBi)	EIRP (dBm)	EIRP (W)
1850.20	-24.58	-52.13	0.00	1.96	29.51	0.89
1880.00	-25.25	-53.17	0.00	2.00	29.92	0.98
1909.80	-26.42	-54.13	0.00	1.98	29.69	0.93



PCS1900 (EDGE) Radiated Power EIRP for 7527C						
Horizontal Polarization						
Frequency (MHz)	Rt (dBm)	Rs (dBm)	Ps (dBm)	Gs (dBi)	EIRP (dBm)	EIRP (W)
1850.20	-31.38	-51.88	0.00	1.96	22.46	0.18
1880.00	-32.15	-52.99	0.00	2.00	22.84	0.19
1909.80	-34.23	-54.28	0.00	1.98	22.03	0.16
Vertical Polarization						
Frequency (MHz)	Rt (dBm)	Rs (dBm)	Ps (dBm)	Gs (dBi)	EIRP (dBm)	EIRP (W)
1850.20	-33.54	-52.13	0.00	1.96	20.55	0.11
1880.00	-35.24	-53.17	0.00	2.00	19.93	0.10
1909.80	-37.46	-54.13	0.00	1.98	18.65	0.07

PCS1900 (EDGE) Radiated Power EIRP for 7527S						
Horizontal Polarization						
Frequency (MHz)	Rt (dBm)	Rs (dBm)	Ps (dBm)	Gs (dBi)	EIRP (dBm)	EIRP (W)
1850.20	-33.70	-51.88	0.00	1.96	20.14	0.10
1880.00	-35.15	-52.99	0.00	2.00	19.84	0.10
1909.80	-36.67	-54.28	0.00	1.98	19.59	0.09
Vertical Polarization						
Frequency (MHz)	Rt (dBm)	Rs (dBm)	Ps (dBm)	Gs (dBi)	EIRP (dBm)	EIRP (W)
1850.20	-33.24	-52.13	0.00	1.96	20.85	0.12
1880.00	-34.66	-53.17	0.00	2.00	20.51	0.11
1909.80	-36.37	-54.13	0.00	1.98	19.74	0.09



GSM850 (GSM) + Endcap 1 + Battery B2 Radiated Power ERP for 7527C						
Horizontal Polarization						
Frequency (MHz)	Rt (dBm)	Rs (dBm)	Ps (dBm)	Gs (dBd)	ERP (dBm)	ERP (W)
NA	NA	NA	NA	NA	NA	NA
836.40	-20.99	-48.28	0.00	-0.93	26.36	0.43
NA	NA	NA	NA	NA	NA	NA
Vertical Polarization						
Frequency (MHz)	Rt (dBm)	Rs (dBm)	Ps (dBm)	Gs (dBd)	ERP (dBm)	ERP (W)
NA	NA	NA	NA	NA	NA	NA
836.40	-20.86	-48.01	0.00	-0.93	26.22	0.42
NA	NA	NA	NA	NA	NA	NA

GSM850 (GSM) + Endcap 2 + Battery B2 Radiated Power ERP for 7527C						
Horizontal Polarization						
Frequency (MHz)	Rt (dBm)	Rs (dBm)	Ps (dBm)	Gs (dBd)	ERP (dBm)	ERP (W)
NA	NA	NA	NA	NA	NA	NA
836.40	-21.09	-48.28	0.00	-0.93	26.26	0.42
NA	NA	NA	NA	NA	NA	NA
Vertical Polarization						
Frequency (MHz)	Rt (dBm)	Rs (dBm)	Ps (dBm)	Gs (dBd)	ERP (dBm)	ERP (W)
NA	NA	NA	NA	NA	NA	NA
836.40	-21.27	-48.01	0.00	-0.93	25.81	0.38
NA	NA	NA	NA	NA	NA	NA



GSM850 (GSM) + Endcap 5 + Battery B2 Radiated Power ERP for 7527C						
Horizontal Polarization						
Frequency (MHz)	Rt (dBm)	Rs (dBm)	Ps (dBm)	Gs (dBd)	ERP (dBm)	ERP (W)
NA	NA	NA	NA	NA	NA	NA
836.40	-21.59	-48.28	0.00	-0.93	25.76	0.38
NA	NA	NA	NA	NA	NA	NA
Vertical Polarization						
Frequency (MHz)	Rt (dBm)	Rs (dBm)	Ps (dBm)	Gs (dBd)	ERP (dBm)	ERP (W)
NA	NA	NA	NA	NA	NA	NA
836.40	-21.00	-48.01	0.00	-0.93	26.08	0.41
NA	NA	NA	NA	NA	NA	NA

GSM850 (GSM) + POD 1 + Battery B2 Radiated Power ERP for 7527C						
Horizontal Polarization						
Frequency (MHz)	Rt (dBm)	Rs (dBm)	Ps (dBm)	Gs (dBd)	ERP (dBm)	ERP (W)
NA	NA	NA	NA	NA	NA	NA
836.40	-20.92	-48.28	0.00	-0.93	26.43	0.44
NA	NA	NA	NA	NA	NA	NA
Vertical Polarization						
Frequency (MHz)	Rt (dBm)	Rs (dBm)	Ps (dBm)	Gs (dBd)	ERP (dBm)	ERP (W)
NA	NA	NA	NA	NA	NA	NA
836.40	-20.91	-48.01	0.00	-0.93	26.17	0.41
NA	NA	NA	NA	NA	NA	NA



GSM850 (GSM) + POD 2 + Battery B2 Radiated Power ERP for 7527C						
Horizontal Polarization						
Frequency (MHz)	Rt (dBm)	Rs (dBm)	Ps (dBm)	Gs (dBd)	ERP (dBm)	ERP (W)
824.20	-21.94	-48.12	0.00	-1.08	25.10	0.32
836.40	-21.51	-48.28	0.00	-0.93	25.84	0.38
848.80	-21.51	-48.35	0.00	-0.76	26.08	0.41
Vertical Polarization						
Frequency (MHz)	Rt (dBm)	Rs (dBm)	Ps (dBm)	Gs (dBd)	ERP (dBm)	ERP (W)
824.20	-22.02	-47.97	0.00	-1.08	24.87	0.31
836.40	-21.01	-48.01	0.00	-0.93	26.07	0.40
848.80	-20.76	-48.05	0.00	-0.76	26.53	0.45

GSM850 (GSM) + POD 3 + Battery B2 Radiated Power ERP for 7527C						
Horizontal Polarization						
Frequency (MHz)	Rt (dBm)	Rs (dBm)	Ps (dBm)	Gs (dBd)	ERP (dBm)	ERP (W)
NA	NA	NA	NA	NA	NA	NA
836.40	-20.99	-48.28	0.00	-0.93	26.36	0.43
NA	NA	NA	NA	NA	NA	NA
Vertical Polarization						
Frequency (MHz)	Rt (dBm)	Rs (dBm)	Ps (dBm)	Gs (dBd)	ERP (dBm)	ERP (W)
NA	NA	NA	NA	NA	NA	NA
836.40	-21.30	-48.01	0.00	-0.93	25.78	0.38
NA	NA	NA	NA	NA	NA	NA



GSM850 (GSM) + POD 4 + Battery B2 Radiated Power ERP for 7527C						
Horizontal Polarization						
Frequency (MHz)	Rt (dBm)	Rs (dBm)	Ps (dBm)	Gs (dBd)	ERP (dBm)	ERP (W)
NA	NA	NA	NA	NA	NA	NA
836.40	-21.09	-48.28	0.00	-0.93	26.26	0.42
NA	NA	NA	NA	NA	NA	NA
Vertical Polarization						
Frequency (MHz)	Rt (dBm)	Rs (dBm)	Ps (dBm)	Gs (dBd)	ERP (dBm)	ERP (W)
NA	NA	NA	NA	NA	NA	NA
836.40	-21.32	-48.01	0.00	-0.93	25.76	0.38
NA	NA	NA	NA	NA	NA	NA

GSM850 (GSM) + POD 6 + Battery B2 Radiated Power ERP for 7527C						
Horizontal Polarization						
Frequency (MHz)	Rt (dBm)	Rs (dBm)	Ps (dBm)	Gs (dBd)	ERP (dBm)	ERP (W)
NA	NA	NA	NA	NA	NA	NA
836.40	-22.15	-48.28	0.00	-0.93	25.20	0.33
NA	NA	NA	NA	NA	NA	NA
Vertical Polarization						
Frequency (MHz)	Rt (dBm)	Rs (dBm)	Ps (dBm)	Gs (dBd)	ERP (dBm)	ERP (W)
NA	NA	NA	NA	NA	NA	NA
836.40	-24.62	-48.01	0.00	-0.93	22.46	0.18
NA	NA	NA	NA	NA	NA	NA



GSM850 (GSM) + POD 2 + Battery B3 Radiated Power ERP for 7527C						
Horizontal Polarization						
Frequency (MHz)	Rt (dBm)	Rs (dBm)	Ps (dBm)	Gs (dBd)	ERP (dBm)	ERP (W)
NA	NA	NA	NA	NA	NA	NA
836.40	-20.92	-48.28	0.00	-0.93	26.43	0.44
NA	NA	NA	NA	NA	NA	NA
Vertical Polarization						
Frequency (MHz)	Rt (dBm)	Rs (dBm)	Ps (dBm)	Gs (dBd)	ERP (dBm)	ERP (W)
NA	NA	NA	NA	NA	NA	NA
836.40	-20.91	-48.01	0.00	-0.93	26.17	0.41
NA	NA	NA	NA	NA	NA	NA

GSM850 (EDGE) + POD 2 + Battery B2 Radiated Power ERP for 7527C						
Horizontal Polarization						
Frequency (MHz)	Rt (dBm)	Rs (dBm)	Ps (dBm)	Gs (dBd)	ERP (dBm)	ERP (W)
824.20	-29.23	-48.12	0.00	-1.08	17.81	0.06
836.40	-29.42	-48.28	0.00	-0.93	17.93	0.06
848.80	-30.86	-48.35	0.00	-0.76	16.73	0.05
Vertical Polarization						
Frequency (MHz)	Rt (dBm)	Rs (dBm)	Ps (dBm)	Gs (dBd)	ERP (dBm)	ERP (W)
824.20	-29.55	-47.97	0.00	-1.08	17.34	0.05
836.40	-29.40	-48.01	0.00	-0.93	17.68	0.06
848.80	-29.31	-48.05	0.00	-0.76	17.98	0.06



GSM850 (GSM) + POD 2 + Battery B2 Radiated Power ERP for 7527S						
Horizontal Polarization						
Frequency (MHz)	Rt (dBm)	Rs (dBm)	Ps (dBm)	Gs (dBd)	ERP (dBm)	ERP (W)
824.20	-20.92	-48.12	0.00	-1.08	26.12	0.41
836.40	-21.31	-48.28	0.00	-0.93	26.04	0.40
848.80	-20.86	-48.35	0.00	-0.76	26.73	0.47
Vertical Polarization						
Frequency (MHz)	Rt (dBm)	Rs (dBm)	Ps (dBm)	Gs (dBd)	ERP (dBm)	ERP (W)
824.20	-22.98	-47.97	0.00	-1.08	23.91	0.25
836.40	-22.26	-48.01	0.00	-0.93	24.82	0.30
848.80	-21.29	-48.05	0.00	-0.76	26.00	0.40

GSM850 (EDGE) + POD 2 + Battery B2 Radiated Power ERP for 7527S						
Horizontal Polarization						
Frequency (MHz)	Rt (dBm)	Rs (dBm)	Ps (dBm)	Gs (dBd)	ERP (dBm)	ERP (W)
824.20	-32.32	-48.12	0.00	-1.08	14.72	0.03
836.40	-32.31	-48.28	0.00	-0.93	15.04	0.03
848.80	-31.86	-48.35	0.00	-0.76	15.73	0.04
Vertical Polarization						
Frequency (MHz)	Rt (dBm)	Rs (dBm)	Ps (dBm)	Gs (dBd)	ERP (dBm)	ERP (W)
824.20	-34.38	-47.97	0.00	-1.08	12.51	0.02
836.40	-33.26	-48.01	0.00	-0.93	13.82	0.02
848.80	-32.29	-48.05	0.00	-0.76	15.00	0.03



PCS1900 (GSM) + Endcap 1 + Battery B2 Radiated Power EIRP for 7527C						
Horizontal Polarization						
Frequency (MHz)	Rt (dBm)	Rs (dBm)	Ps (dBm)	Gs (dBi)	EIRP (dBm)	EIRP (W)
NA	NA	NA	NA	NA	NA	NA
1880.00	-25.33	-52.99	0.00	2.00	29.66	0.92
NA	NA	NA	NA	NA	NA	NA
Vertical Polarization						
Frequency (MHz)	Rt (dBm)	Rs (dBm)	Ps (dBm)	Gs (dBi)	EIRP (dBm)	EIRP (W)
NA	NA	NA	NA	NA	NA	NA
1880.00	-27.40	-53.17	0.00	2.00	27.77	0.60
NA	NA	NA	NA	NA	NA	NA

PCS1900 (GSM) + Endcap 2 + Battery B2 Radiated Power EIRP for 7527C						
Horizontal Polarization						
Frequency (MHz)	Rt (dBm)	Rs (dBm)	Ps (dBm)	Gs (dBi)	EIRP (dBm)	EIRP (W)
NA	NA	NA	NA	NA	NA	NA
1880.00	-26.54	-52.99	0.00	2.00	28.45	0.70
NA	NA	NA	NA	NA	NA	NA
Vertical Polarization						
Frequency (MHz)	Rt (dBm)	Rs (dBm)	Ps (dBm)	Gs (dBi)	EIRP (dBm)	EIRP (W)
NA	NA	NA	NA	NA	NA	NA
1880.00	-27.40	-53.17	0.00	2.00	27.77	0.60
NA	NA	NA	NA	NA	NA	NA



PCS1900 (GSM) + Endcap 5 + Battery B2 Radiated Power EIRP for 7527C						
Horizontal Polarization						
Frequency (MHz)	Rt (dBm)	Rs (dBm)	Ps (dBm)	Gs (dBi)	EIRP (dBm)	EIRP (W)
NA	NA	NA	NA	NA	NA	NA
1880.00	-26.92	-52.99	0.00	2.00	28.07	0.64
NA	NA	NA	NA	NA	NA	NA
Vertical Polarization						
Frequency (MHz)	Rt (dBm)	Rs (dBm)	Ps (dBm)	Gs (dBi)	EIRP (dBm)	EIRP (W)
NA	NA	NA	NA	NA	NA	NA
1880.00	-27.36	-53.17	0.00	2.00	27.81	0.60
NA	NA	NA	NA	NA	NA	NA

PCS1900 (GSM) + POD 1 + Battery B2 Radiated Power EIRP for 7527C						
Horizontal Polarization						
Frequency (MHz)	Rt (dBm)	Rs (dBm)	Ps (dBm)	Gs (dBi)	EIRP (dBm)	EIRP (W)
NA	NA	NA	NA	NA	NA	NA
1880.00	-25.26	-52.99	0.00	2.00	29.73	0.94
NA	NA	NA	NA	NA	NA	NA
Vertical Polarization						
Frequency (MHz)	Rt (dBm)	Rs (dBm)	Ps (dBm)	Gs (dBi)	EIRP (dBm)	EIRP (W)
NA	NA	NA	NA	NA	NA	NA
1880.00	-27.39	-53.17	0.00	2.00	27.78	0.60
NA	NA	NA	NA	NA	NA	NA



PCS1900 (GSM) + POD 2 + Battery B2 Radiated Power EIRP for 7527C						
Horizontal Polarization						
Frequency (MHz)	Rt (dBm)	Rs (dBm)	Ps (dBm)	Gs (dBi)	EIRP (dBm)	EIRP (W)
1850.20	-24.25	-51.88	0.00	1.96	29.59	0.91
1880.00	-26.06	-52.99	0.00	2.00	28.93	0.78
1909.80	-28.64	-54.28	0.00	1.98	27.62	0.58
Vertical Polarization						
Frequency (MHz)	Rt (dBm)	Rs (dBm)	Ps (dBm)	Gs (dBi)	EIRP (dBm)	EIRP (W)
1850.20	-26.47	-52.13	0.00	1.96	27.62	0.58
1880.00	-28.04	-53.17	0.00	2.00	27.13	0.52
1909.80	-30.68	-54.13	0.00	1.98	25.43	0.35

PCS1900 (GSM) + POD 3 + Battery B2 Radiated Power EIRP for 7527C						
Horizontal Polarization						
Frequency (MHz)	Rt (dBm)	Rs (dBm)	Ps (dBm)	Gs (dBi)	EIRP (dBm)	EIRP (W)
NA	NA	NA	NA	NA	NA	NA
1880.00	-25.54	-52.99	0.00	2.00	29.45	0.88
NA	NA	NA	NA	NA	NA	NA
Vertical Polarization						
Frequency (MHz)	Rt (dBm)	Rs (dBm)	Ps (dBm)	Gs (dBi)	EIRP (dBm)	EIRP (W)
NA	NA	NA	NA	NA	NA	NA
1880.00	-28.63	-53.17	0.00	2.00	26.54	0.45
NA	NA	NA	NA	NA	NA	NA



PCS1900 (GSM) + POD 4 + Battery B2 Radiated Power EIRP for 7527C						
Horizontal Polarization						
Frequency (MHz)	Rt (dBm)	Rs (dBm)	Ps (dBm)	Gs (dBi)	EIRP (dBm)	EIRP (W)
NA	NA	NA	NA	NA	NA	NA
1880.00	-25.51	-52.99	0.00	2.00	29.48	0.89
NA	NA	NA	NA	NA	NA	NA
Vertical Polarization						
Frequency (MHz)	Rt (dBm)	Rs (dBm)	Ps (dBm)	Gs (dBi)	EIRP (dBm)	EIRP (W)
NA	NA	NA	NA	NA	NA	NA
1880.00	-28.30	-53.17	0.00	2.00	26.87	0.49
NA	NA	NA	NA	NA	NA	NA

PCS1900 (GSM) + POD 6 + Battery B2 Radiated Power EIRP for 7527C						
Horizontal Polarization						
Frequency (MHz)	Rt (dBm)	Rs (dBm)	Ps (dBm)	Gs (dBi)	EIRP (dBm)	EIRP (W)
NA	NA	NA	NA	NA	NA	NA
1880.00	-25.94	-52.99	0.00	2.00	29.05	0.80
NA	NA	NA	NA	NA	NA	NA
Vertical Polarization						
Frequency (MHz)	Rt (dBm)	Rs (dBm)	Ps (dBm)	Gs (dBi)	EIRP (dBm)	EIRP (W)
NA	NA	NA	NA	NA	NA	NA
1880.00	-26.50	-53.17	0.00	2.00	28.67	0.74
NA	NA	NA	NA	NA	NA	NA



PCS1900 (GSM) + POD 2 + Battery B3 Radiated Power EIRP for 7527C						
Horizontal Polarization						
Frequency (MHz)	Rt (dBm)	Rs (dBm)	Ps (dBm)	Gs (dBi)	EIRP (dBm)	EIRP (W)
NA	NA	NA	NA	NA	NA	NA
1880.00	-25.26	-52.99	0.00	2.00	29.73	0.94
NA	NA	NA	NA	NA	NA	NA
Vertical Polarization						
Frequency (MHz)	Rt (dBm)	Rs (dBm)	Ps (dBm)	Gs (dBi)	EIRP (dBm)	EIRP (W)
NA	NA	NA	NA	NA	NA	NA
1880.00	-27.39	-53.17	0.00	2.00	27.78	0.60
NA	NA	NA	NA	NA	NA	NA

PCS1900 (EDGE) + POD 2 + Battery 2 Radiated Power EIRP for 7527C						
Horizontal Polarization						
Frequency (MHz)	Rt (dBm)	Rs (dBm)	Ps (dBm)	Gs (dBi)	EIRP (dBm)	EIRP (W)
1850.20	-31.29	-51.88	0.00	1.96	22.55	0.18
1880.00	-33.03	-52.99	0.00	2.00	21.96	0.16
1909.80	-34.71	-54.28	0.00	1.98	21.55	0.14
Vertical Polarization						
Frequency (MHz)	Rt (dBm)	Rs (dBm)	Ps (dBm)	Gs (dBi)	EIRP (dBm)	EIRP (W)
1850.20	-33.14	-52.13	0.00	1.96	20.95	0.12
1880.00	-34.76	-53.17	0.00	2.00	20.41	0.11
1909.80	-36.16	-54.13	0.00	1.98	19.95	0.10



PCS1900 (GSM) + POD 2 + Battery 2 Radiated Power EIRP for 7527S						
Horizontal Polarization						
Frequency (MHz)	Rt (dBm)	Rs (dBm)	Ps (dBm)	Gs (dBi)	EIRP (dBm)	EIRP (W)
1850.20	-32.97	-51.88	0.00	1.96	20.87	0.12
1880.00	-28.04	-52.99	0.00	2.00	26.95	0.50
1909.80	-29.11	-54.28	0.00	1.98	27.15	0.52
Vertical Polarization						
Frequency (MHz)	Rt (dBm)	Rs (dBm)	Ps (dBm)	Gs (dBi)	EIRP (dBm)	EIRP (W)
1850.20	-26.60	-52.13	0.00	1.96	27.49	0.56
1880.00	-27.88	-53.17	0.00	2.00	27.29	0.54
1909.80	-29.26	-54.13	0.00	1.98	26.85	0.48

PCS1900 (EDGE) + POD 2 + Battery 2 Radiated Power EIRP for 7527S						
Horizontal Polarization						
Frequency (MHz)	Rt (dBm)	Rs (dBm)	Ps (dBm)	Gs (dBi)	EIRP (dBm)	EIRP (W)
1850.20	-41.27	-51.88	0.00	1.96	12.57	0.02
1880.00	-36.84	-52.99	0.00	2.00	18.15	0.07
1909.80	-38.51	-54.28	0.00	1.98	17.75	0.06
Vertical Polarization						
Frequency (MHz)	Rt (dBm)	Rs (dBm)	Ps (dBm)	Gs (dBi)	EIRP (dBm)	EIRP (W)
1850.20	-34.90	-52.13	0.00	1.96	19.19	0.08
1880.00	-36.68	-53.17	0.00	2.00	18.49	0.07
1909.80	-38.66	-54.13	0.00	1.98	17.45	0.06

4.4 Occupied Bandwidth and Band Edge Measurement

4.4.1 Measurement Instruments

As described in chapter 5 of this test report.

4.4.2 Test Procedure

1. The EUT was connected to Spectrum Analyzer and Base Station via power divider.
2. The 99% occupied bandwidth of middle channel for the highest and lowest RF powers were measured.
3. The bandedge of low and high channels for the highest RF powers within the transmitting frequency band were measured. Setting RBW as roughly $BW/100$.

4.4.3 Test Setup Layout

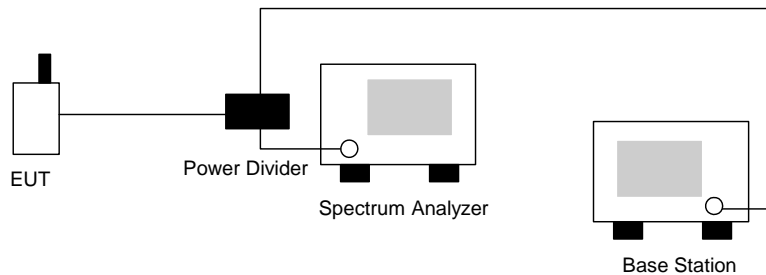



4.4.4 Test Result

- Mode 1
- Test Mode : GSM850 (GSM) CH128 Lower Band Edge
- Power State : High

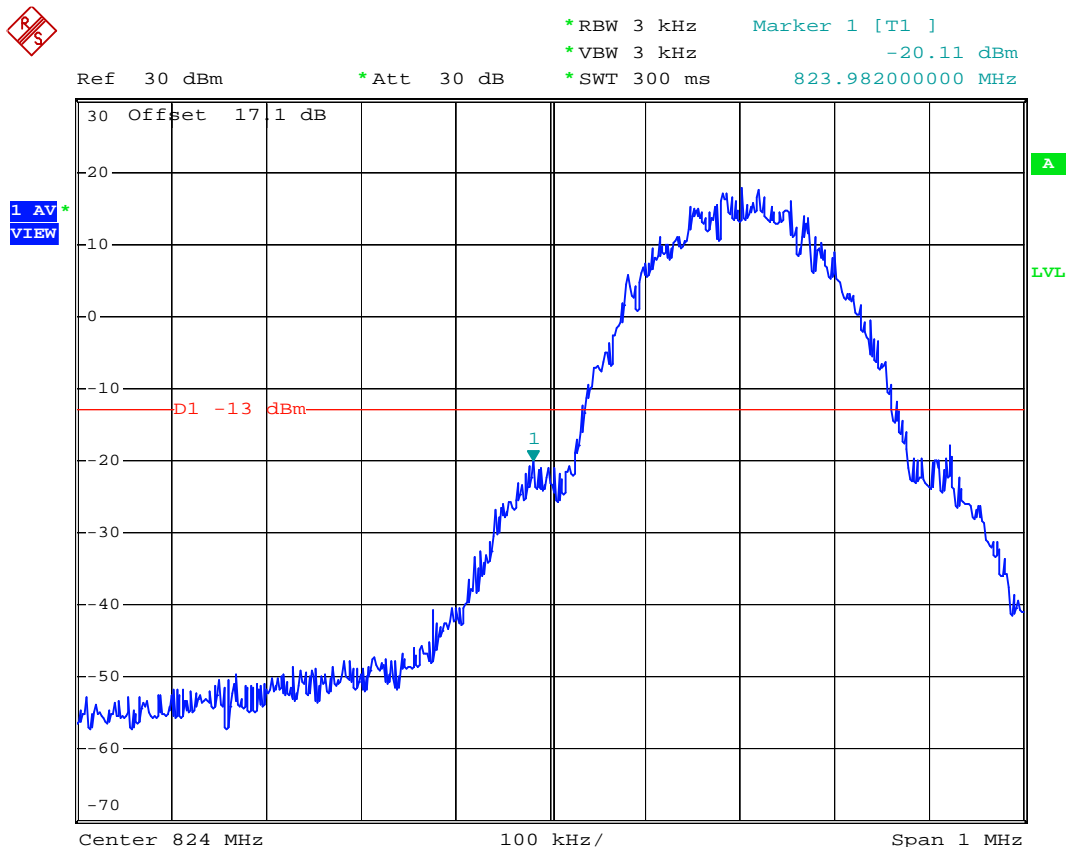

Date: 1.DEC.2006 16:20:47



Ref 30 dBm * Att 30 dB * RBW 3 kHz Marker 1 [T1] -16.48 dBm
* VBW 10 kHz 823.996794872 MHz
* SWT 300 ms

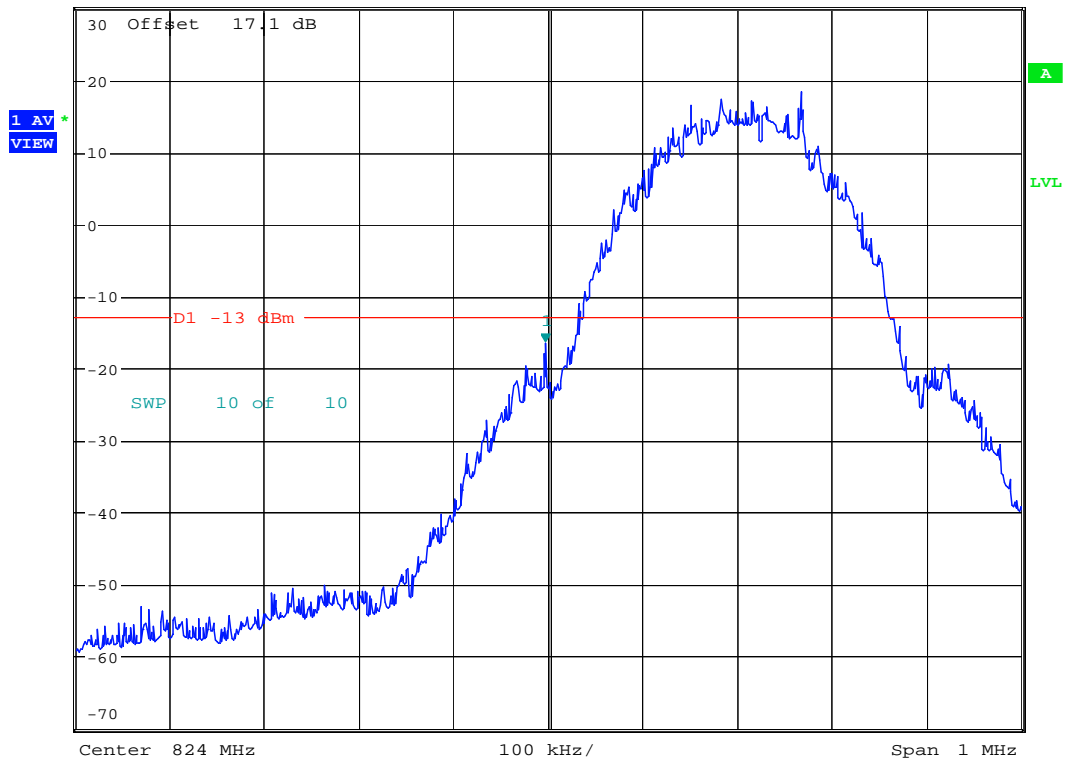

Date: 28.MAR.2007 14:49:05



- Test Mode : GSM850 (GSM) CH189 99% Occupied Bandwidth
- Power State : Low

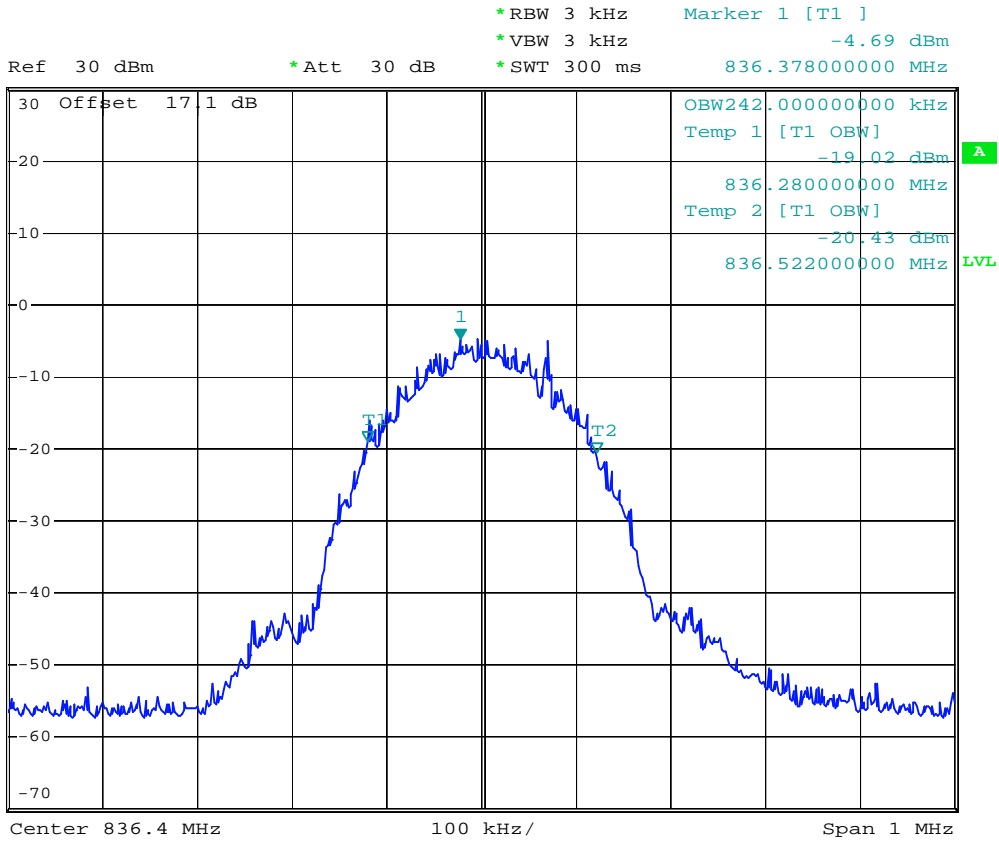

Date: 1.DEC.2006 16:11:03



- Test Mode : GSM850 (GSM) CH189 99% Occupied Bandwidth
- Power State : High

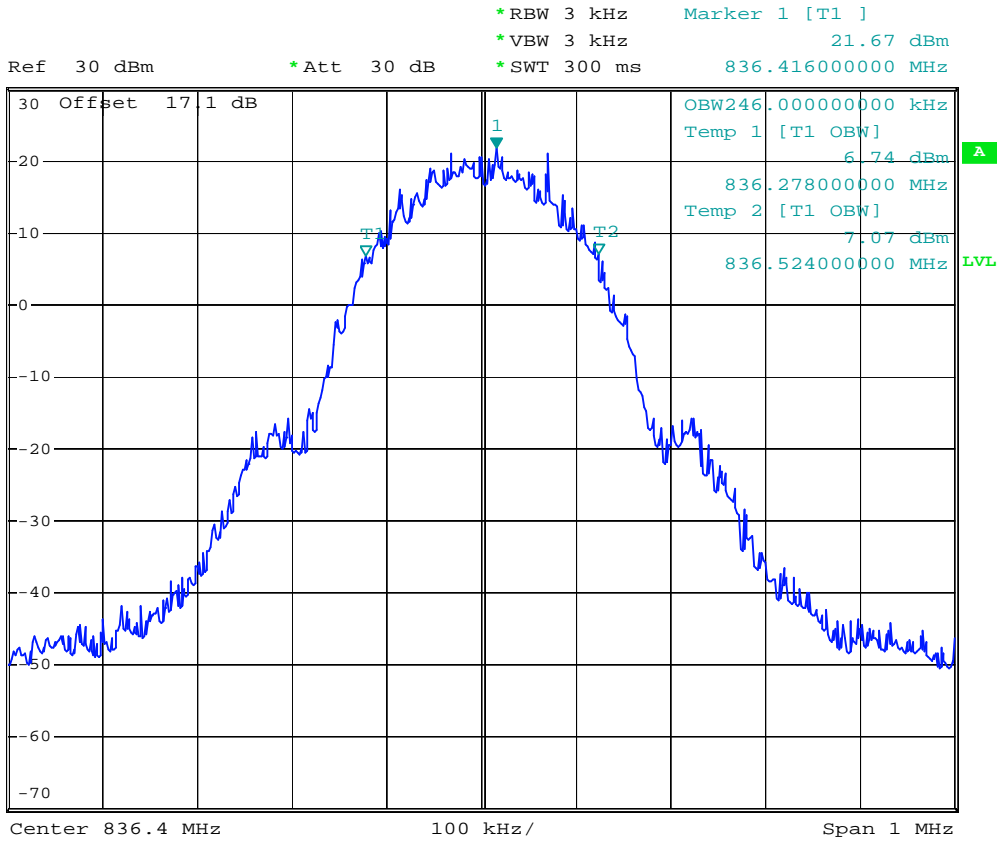

Date: 1.DEC.2006 16:09:57



*RBW 3 kHz Marker 1 [T1] 23.33 dBm
*VBW 30 kHz
*SWT 300 ms 836.36800000 MHz

Ref 30 dBm

*Att 30 dB

1 PK
VIEW

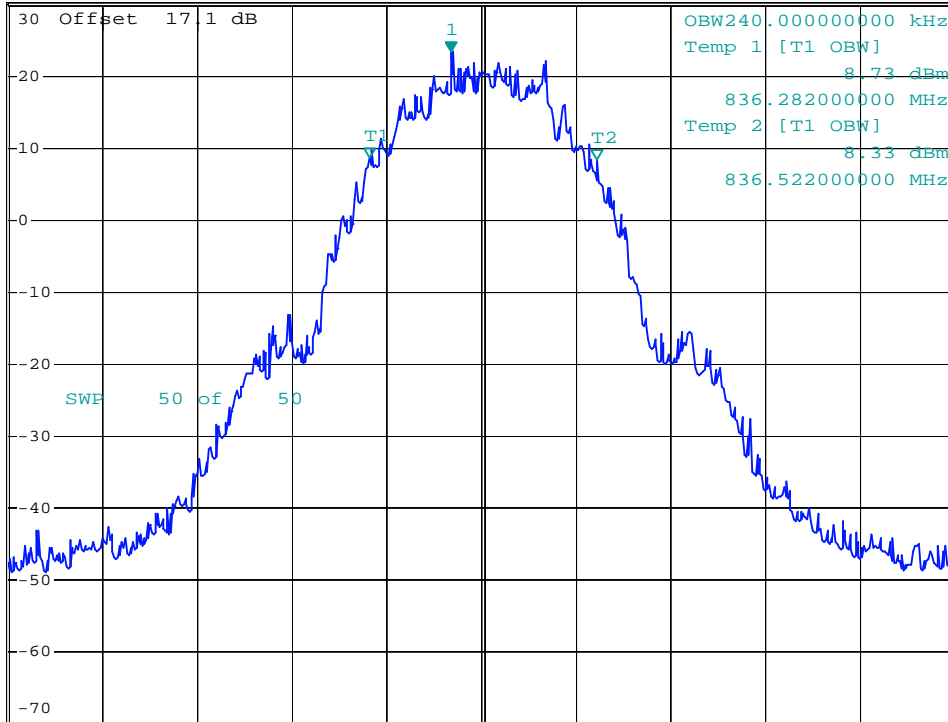

Center 836.4 MHz 100 kHz/ Span 1 MHz

Date: 1.DEC.2006 16:18:57



- Test Mode : GSM850 (GSM) CH251 Higher Band Edge
- Power State : High



Date: 1.DEC.2006 16:21:28



Ref 30 dBm * Att 30 dB * RBW 3 kHz Marker 1 [T1] -18.63 dBm
* VBW 10 kHz * SWT 300 ms 849.020833333 MHz

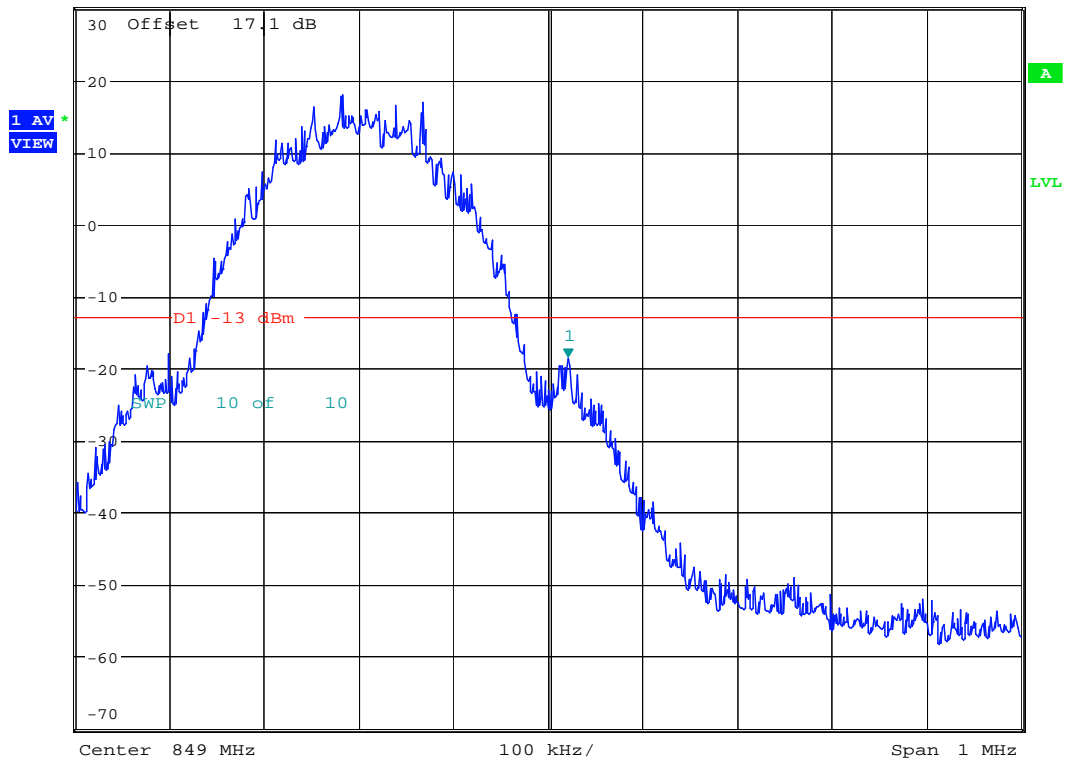

Date: 28.MAR.2007 14:46:42



- Mode 2
- Test Mode : GSM850 (EDGE) CH128 Lower Band Edge
- Power State : High



Ref 30 dBm *Att 30 dB *RBW 3 kHz Marker 1 [T1]
 *VBW 3 kHz -21.12 dBm
 *SWT 300 ms 823.998000000 MHz

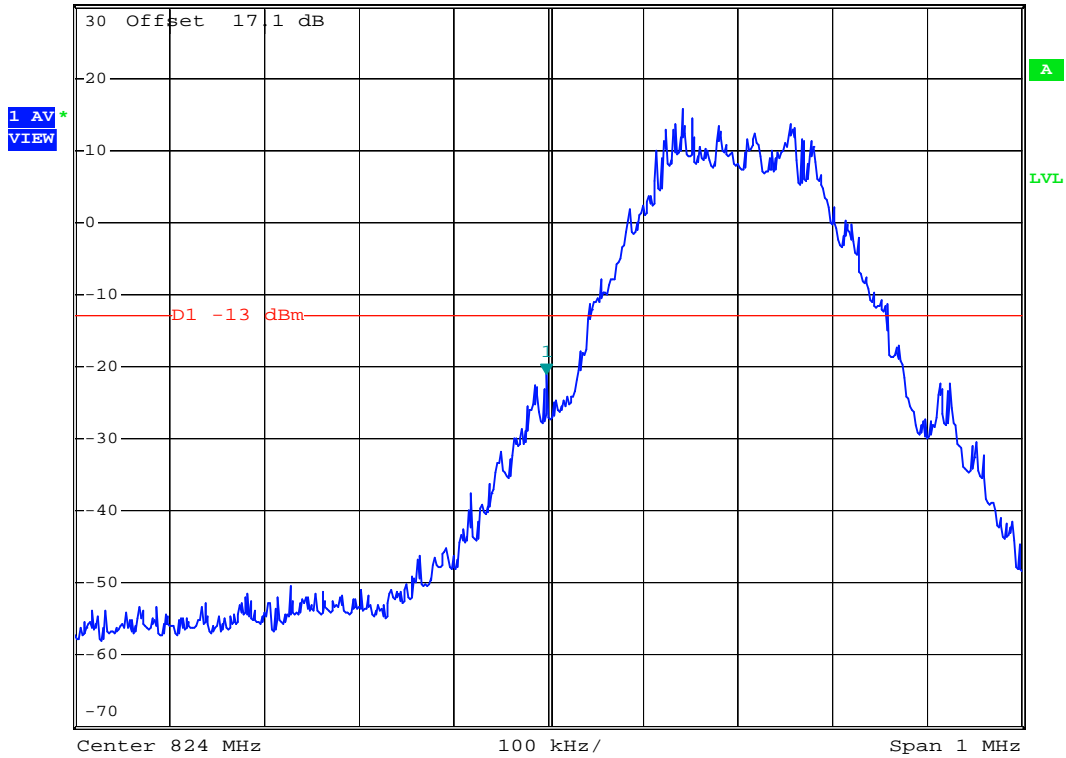

Date: 7.FEB.2007 15:06:32



* RBW 3 kHz Marker 1 [T1]
 * VBW 10 kHz -21.09 dBm
 * SWT 300 ms 823.985576923 MHz

Ref 30 dBm * Att 30 dB

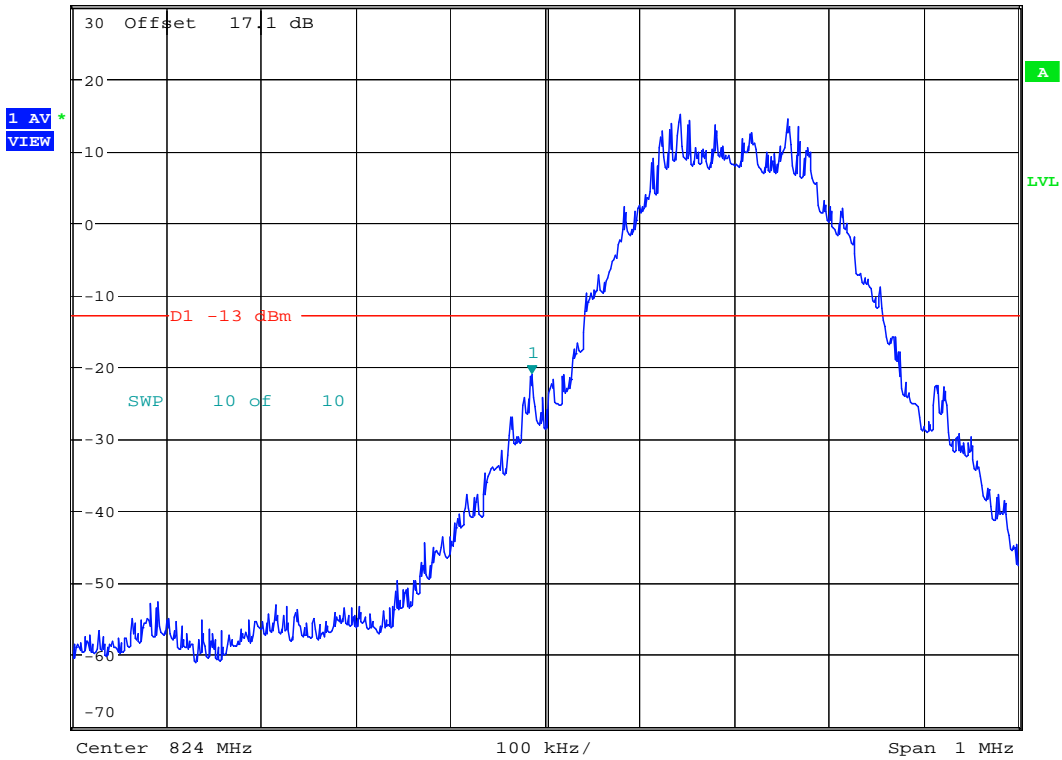

Date: 28.MAR.2007 14:58:08



- Test Mode : GSM850 (EDGE) CH189 99% Occupied Bandwidth
- Power State : High

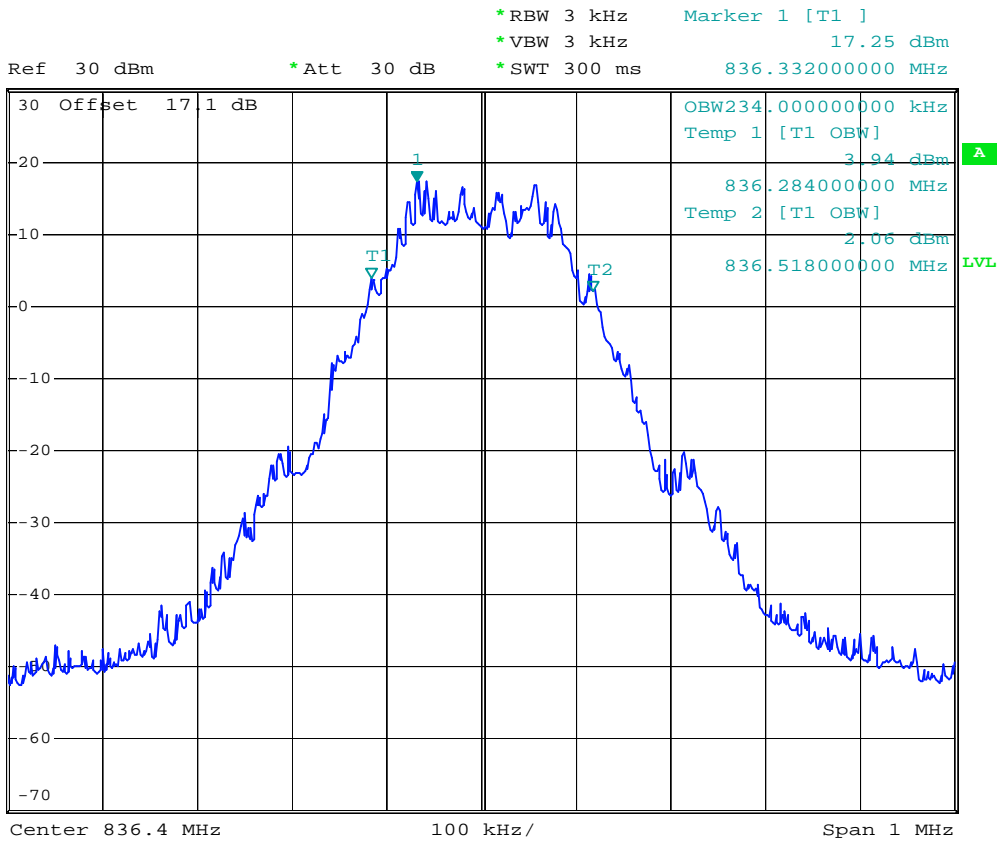

Date: 9.FEB.2007 14:33:24



*RBW 3 kHz Marker 1 [T1]
 *VBW 30 kHz 16.33 dBm
 *SWT 300 ms 836.342000000 MHz

Ref 30 dBm

*Att 30 dB

1 PK
VIEW

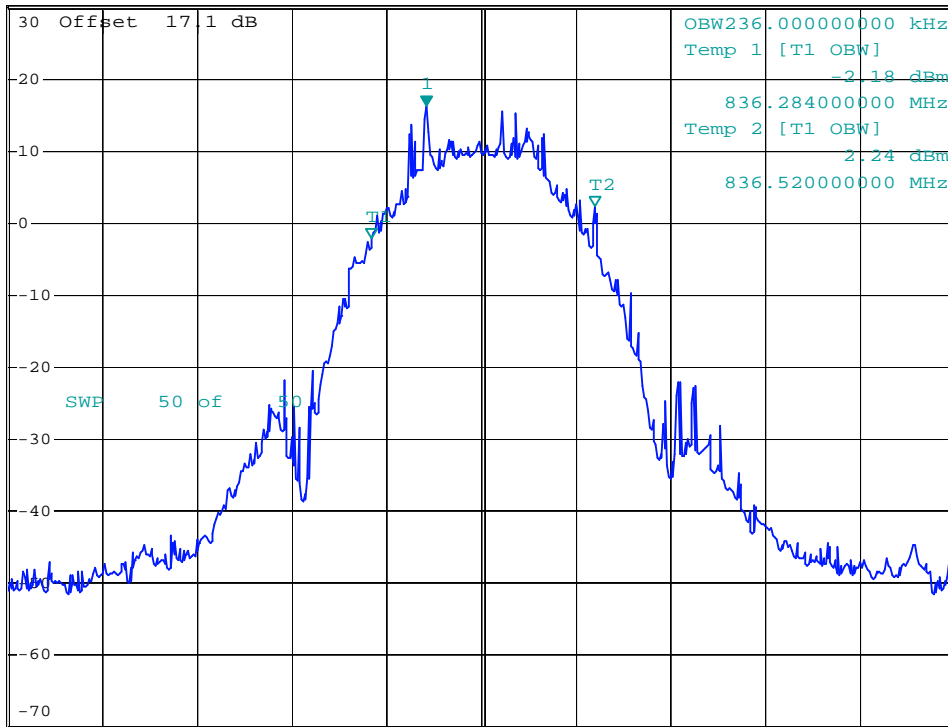

Center 836.4 MHz 100 kHz/ Span 1 MHz

Date: 9.FEB.2007 14:32:22



- Test Mode : GSM850 (EDGE) CH251 Higher Band Edge
- Power State : High



Ref 30 dBm *Att 30 dB *RBW 3 kHz Marker 1 [T1]
*VBW 3 kHz -22.67 dBm
*SWT 300 ms 849.014000000 MHz

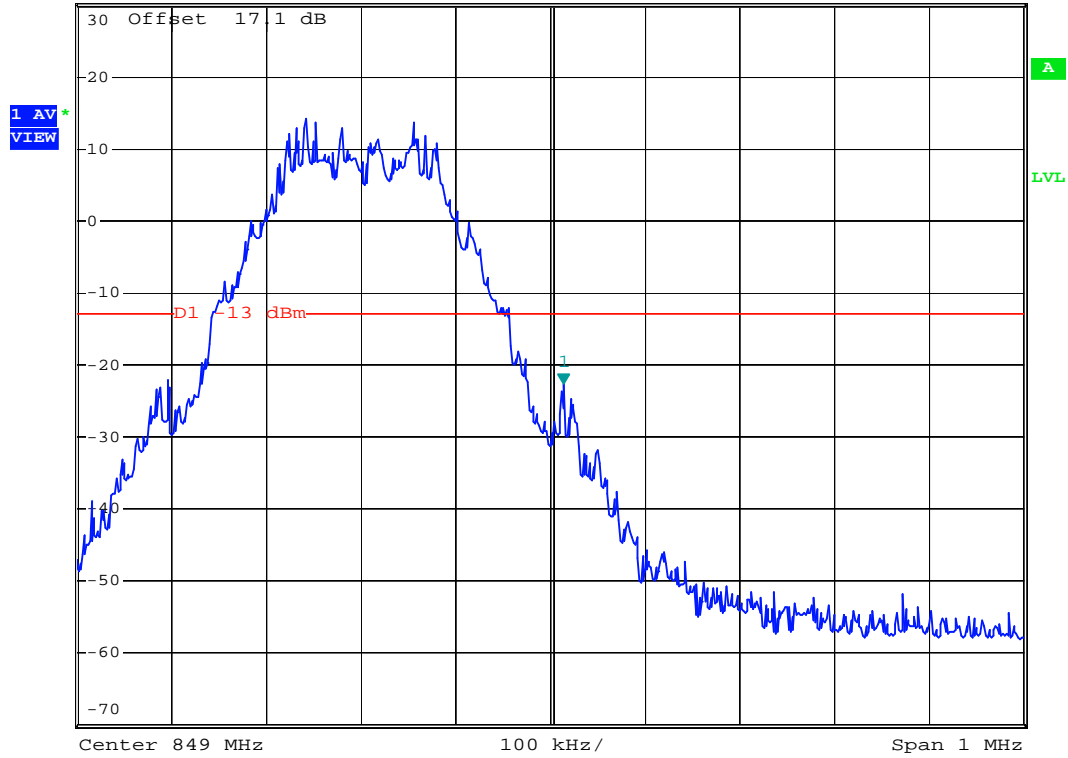

Date: 7.FEB.2007 15:07:10



Ref 30 dBm * Att 30 dB * RBW 3 kHz Marker 1 [T1] -22.84 dBm
* VBW 10 kHz 849.014423077 MHz
* SWT 300 ms

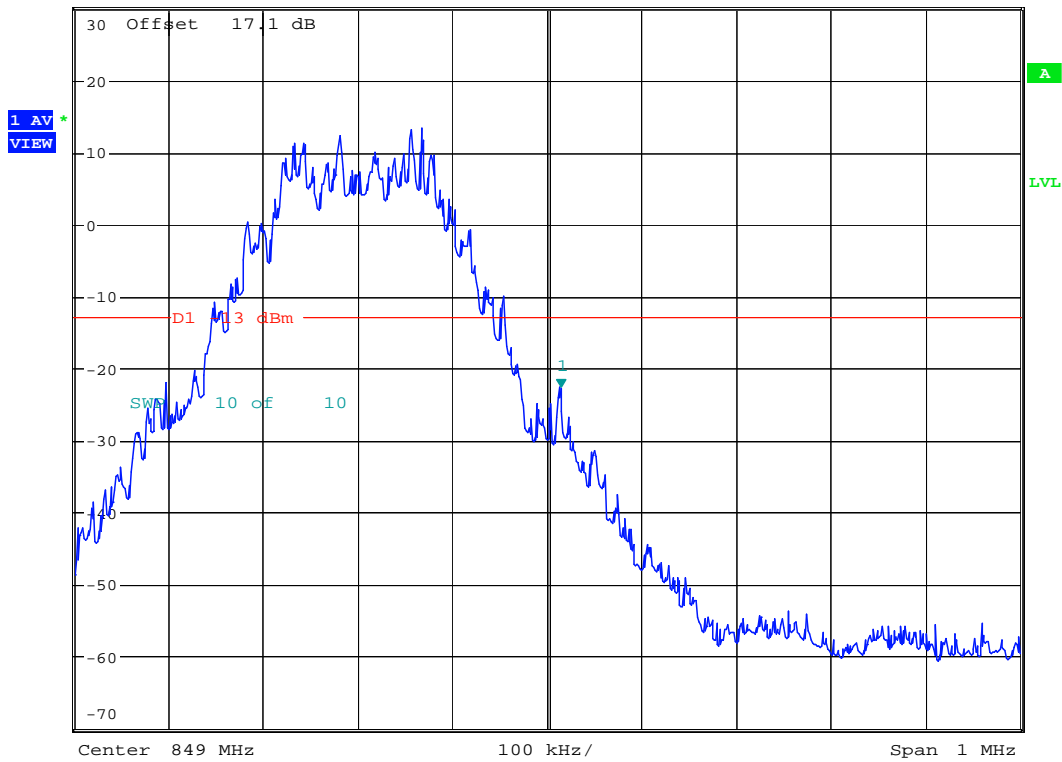

Date: 28.MAR.2007 14:43:26



- Mode 3
- Test Mode : PCS1900 (GSM) CH512 Lower Band Edge
- Power State : High



Ref 30 dBm * Att 30 dB * RBW 3 kHz Marker 1 [T1]
* VBW 3 kHz -17.91 dBm
* SWT 300 ms 1.849998000 GHz

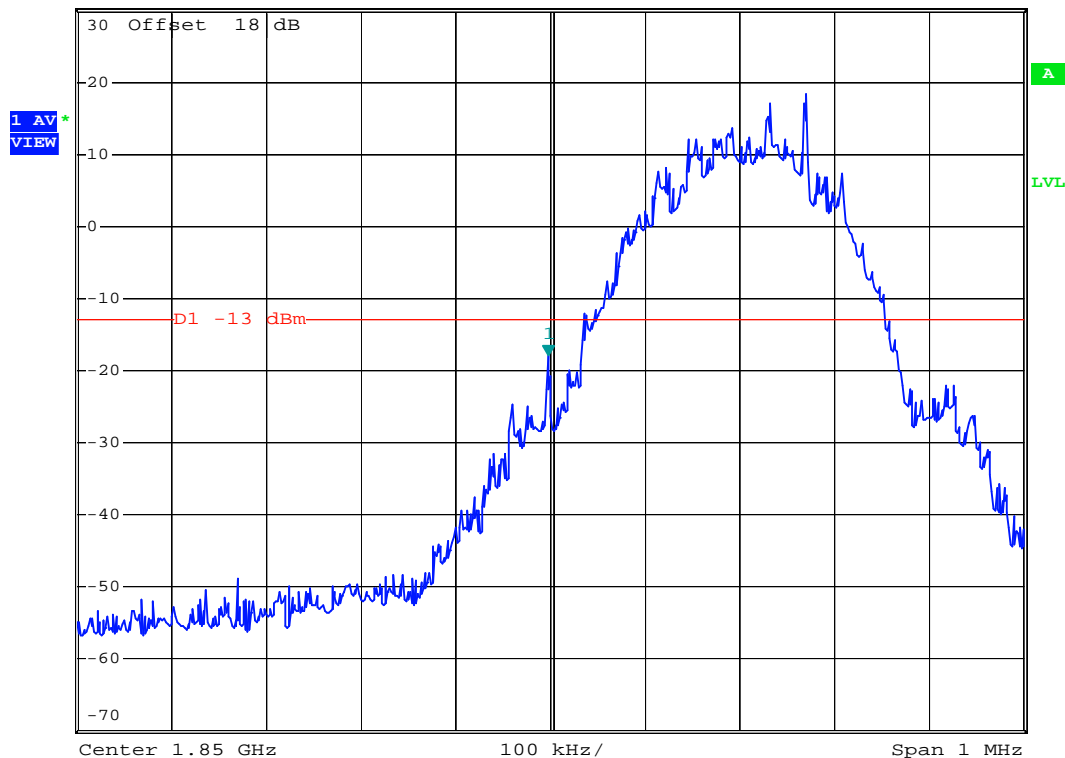

Date: 1.DEC.2006 16:51:34

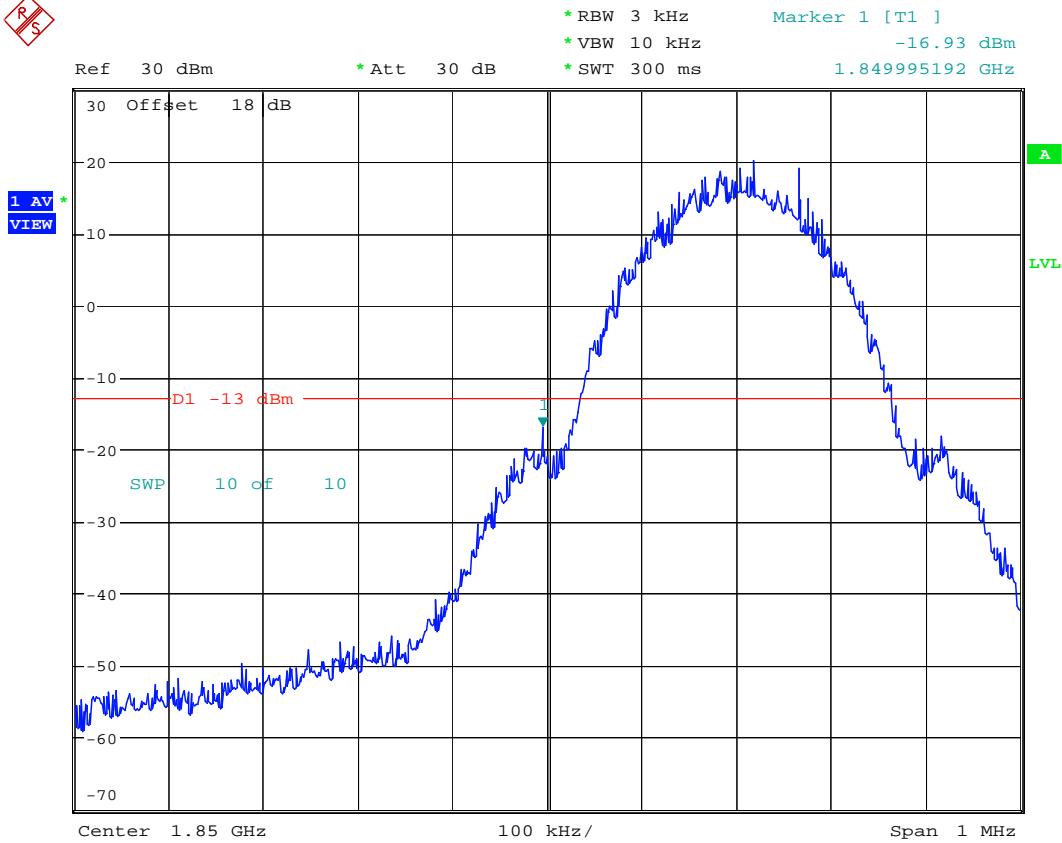

Date: 28.MAR.2007 12:44:28



- Test Mode : PCS1900 (GSM) CH661 99% Occupied Bandwidth
- Power State : Low

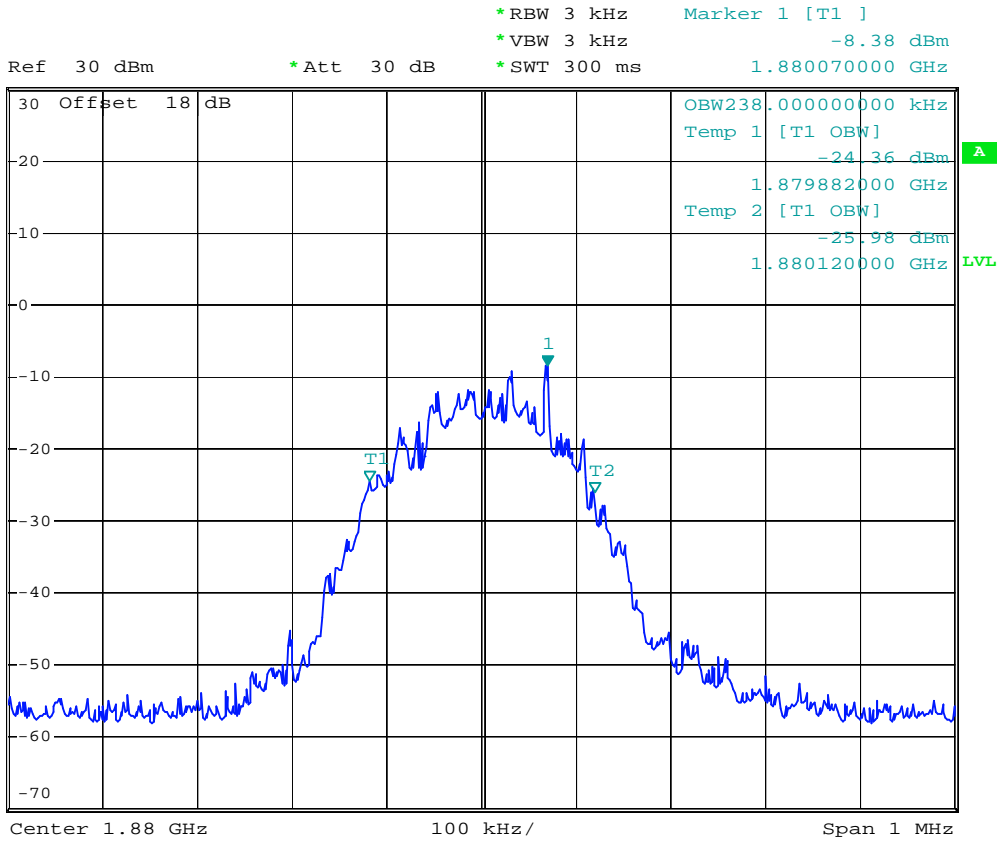

Date: 1.DEC.2006 16:48:24



- Test Mode : PCS1900 (GSM) CH661 99% Occupied Bandwidth
- Power State : High

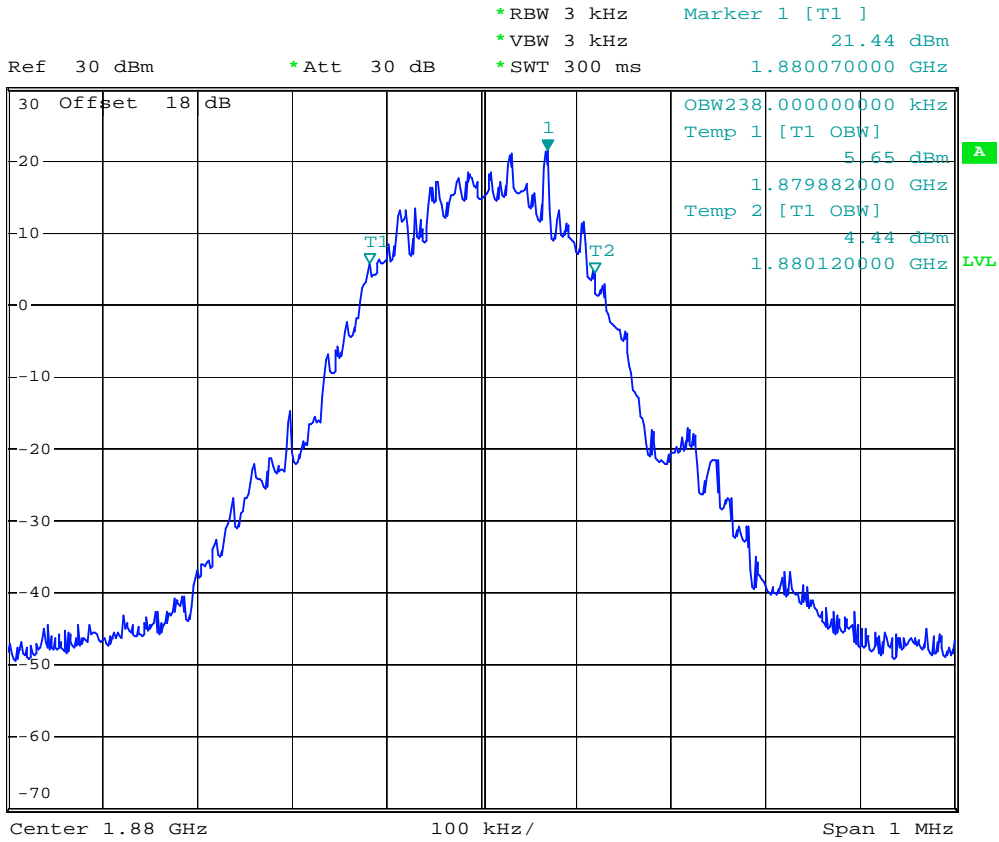

Date: 1.DEC.2006 16:47:51

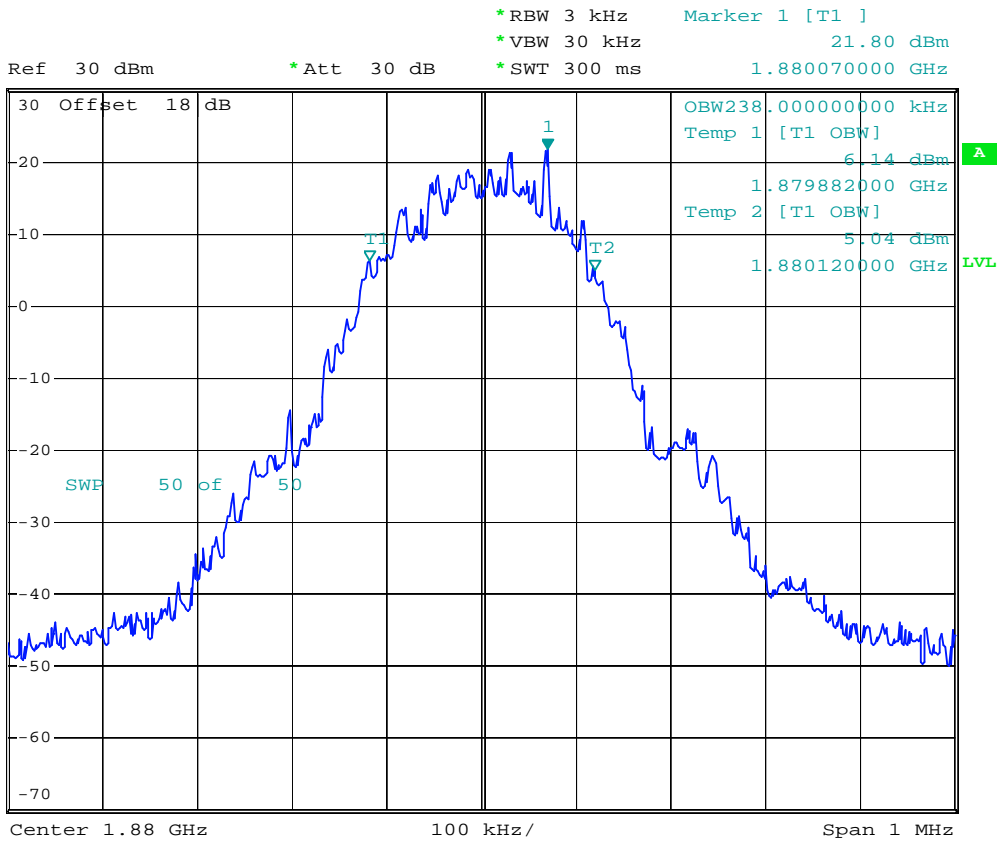

Date: 1.DEC.2006 16:46:40



- Test Mode : PCS1900 (GSM) CH810 Higher Band Edge
- Power State : High



*RBW 3 kHz Marker 1 [T1]
 *VBW 3 kHz -22.11 dBm
 *SWT 300 ms 1.910026000 GHz

Ref 30 dBm

*Att 30 dB

1 AV
VIEW

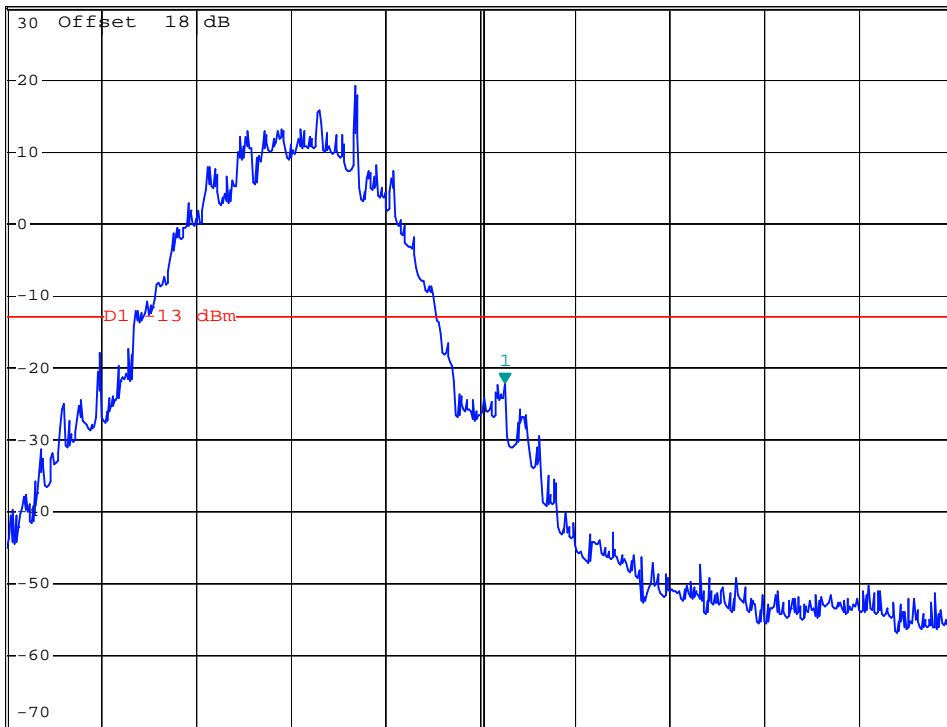

Center 1.91 GHz

100 kHz/

Span 1 MHz

Date: 1.DEC.2006 16:50:12



Ref 30 dBm * Att 30 dB * RBW 3 kHz Marker 1 [T1]
 * VBW 10 kHz -20.60 dBm
 * SWT 300 ms 1.910014423 GHz

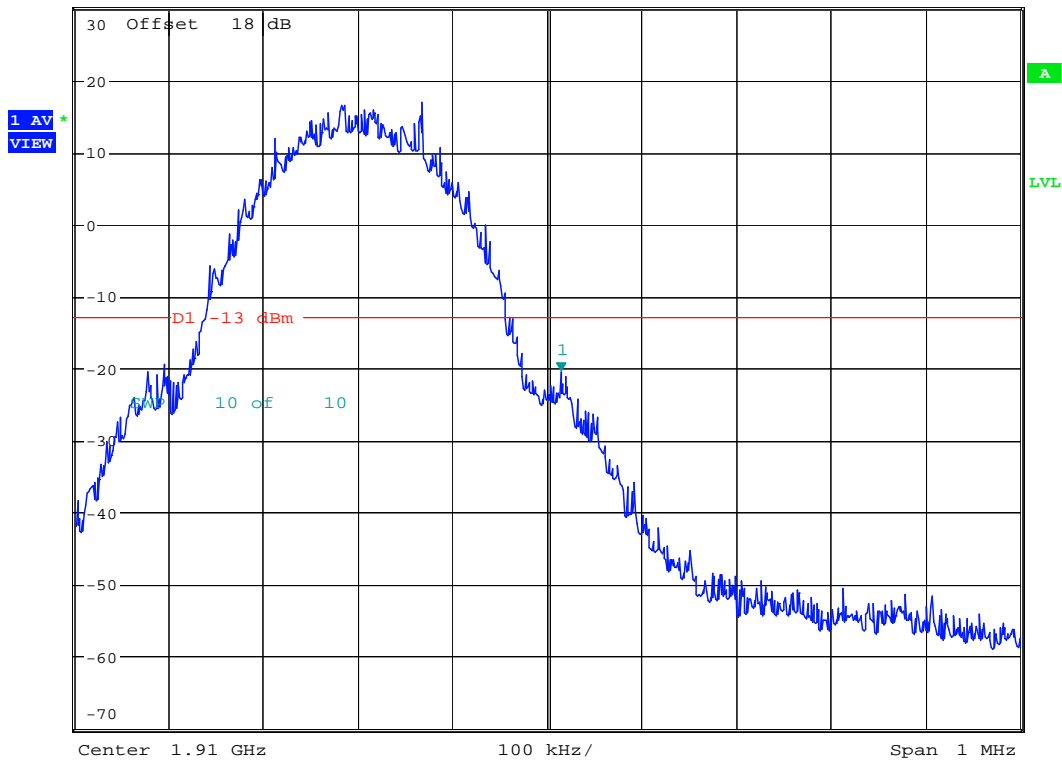

Date: 28.MAR.2007 12:46:04



- Mode 4
- Test Mode : PCS1900 (EDGE) CH512 Lower Band Edge
- Power State : High



Ref 30 dBm *Att 30 dB *RBW 3 kHz Marker 1 [T1]
 *VBW 3 kHz -26.37 dBm
 *SWT 300 ms 1.849996000 GHz

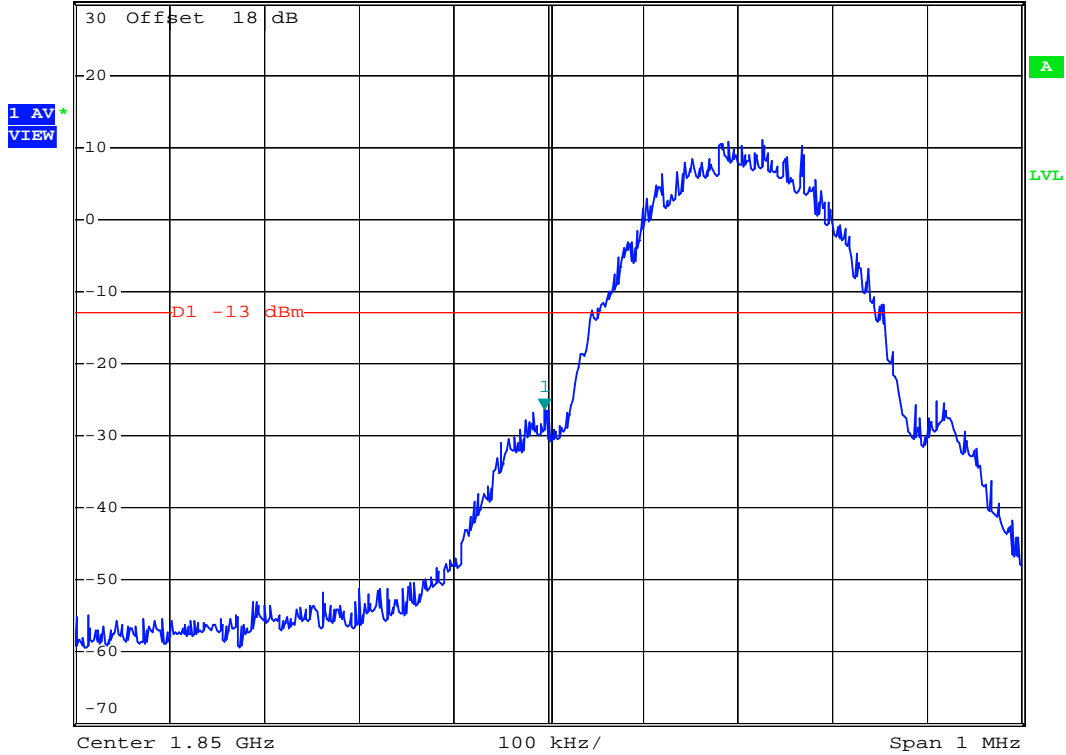

Date: 12.FEB.2007 11:16:12



Ref 30 dBm * Att 30 dB * RBW 3 kHz * VBW 10 kHz * SWT 300 ms Marker 1 [T1] -22.25 dBm 1.849987179 GHz

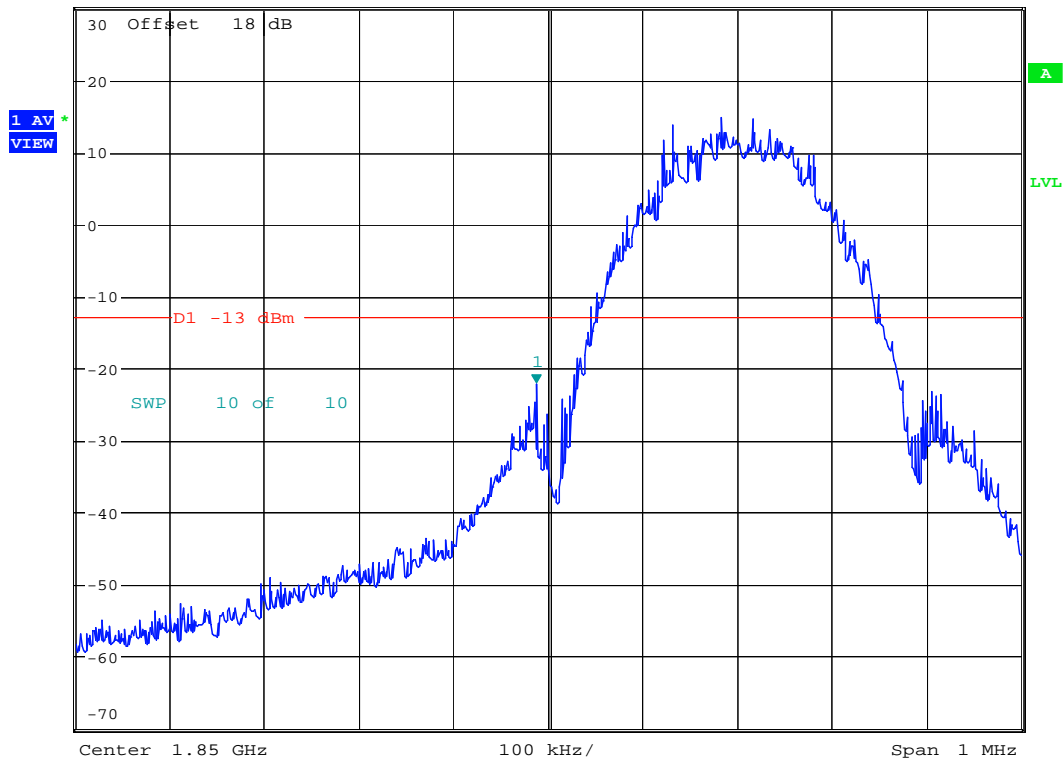

Date: 28.MAR.2007 13:41:30



- Test Mode : PCS1900(EDGE) CH661 99% Occupied Bandwidth
- Power State : High



*RBW 3 kHz Marker 1 [T1]
 *VBW 3 kHz 17.09 dBm
 *SWT 300 ms 1.879984000 GHz

Ref 30 dBm

*Att 30 dB

1 PK VIEW

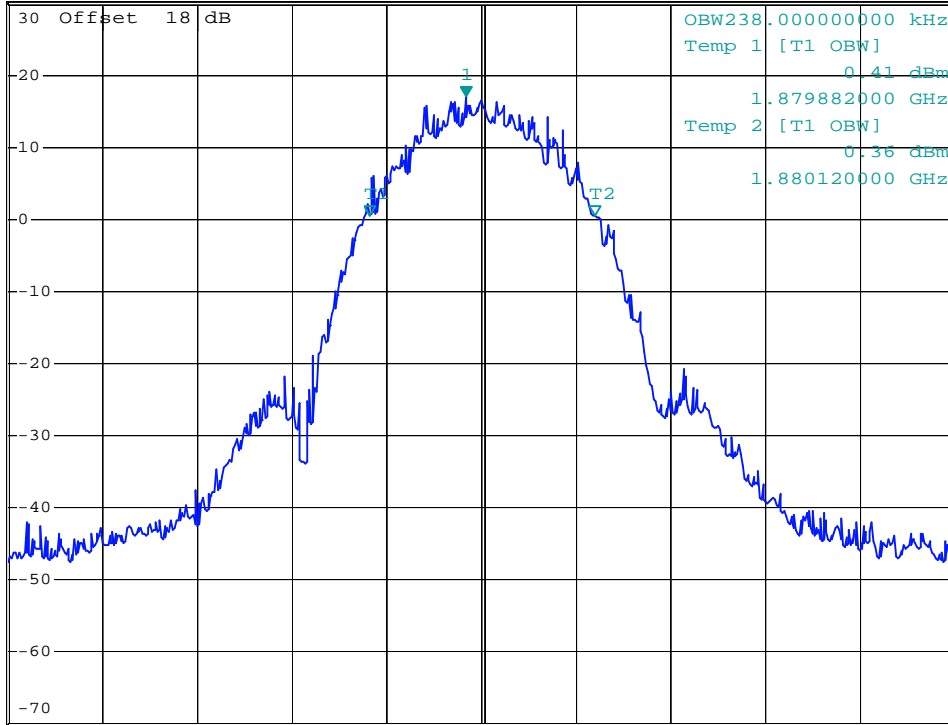

Center 1.88 GHz

100 kHz/

Span 1 MHz

Date: 7.FEB.2007 19:22:41



*RBW 3 kHz Marker 1 [T1] 12.52 dBm
*VBW 30 kHz
*SWT 300 ms 1.880016000 GHz

Ref 30 dBm

*Att 30 dB

1 PK
VIEW

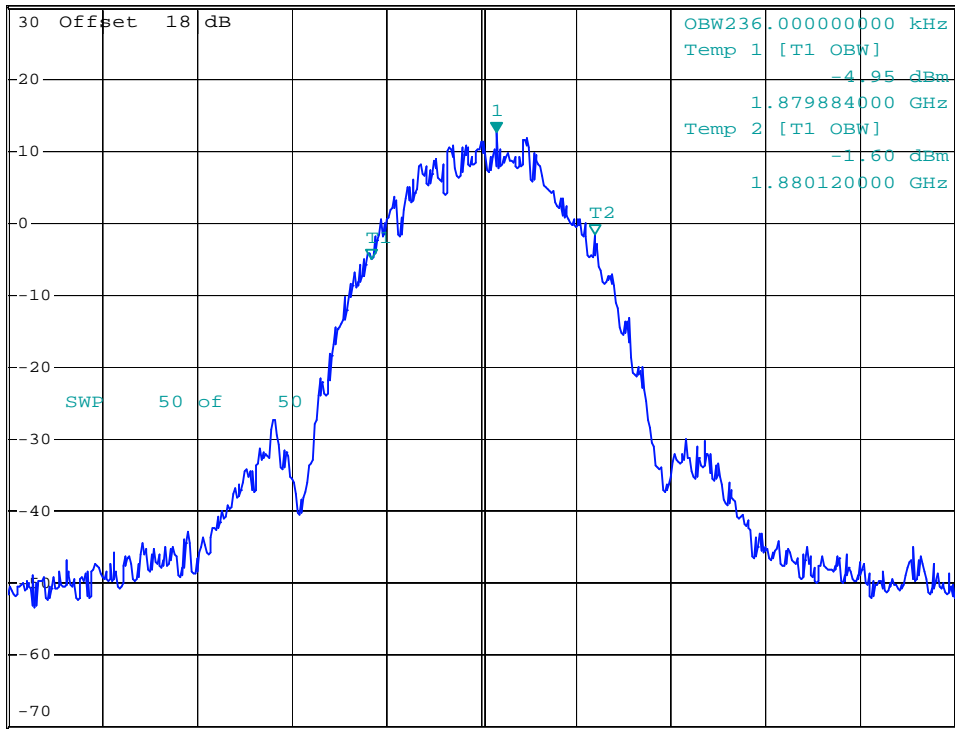

Date: 9.FEB.2007 14:45:20



- Test Mode : PCS1900(EDGE) CH810 Higher Band Edge
- Power State : High



Ref 30 dBm *Att 30 dB *RBW 3 kHz Marker 1 [T1]
*VBW 3 kHz -23.85 dBm
*SWT 300 ms 1.910022000 GHz

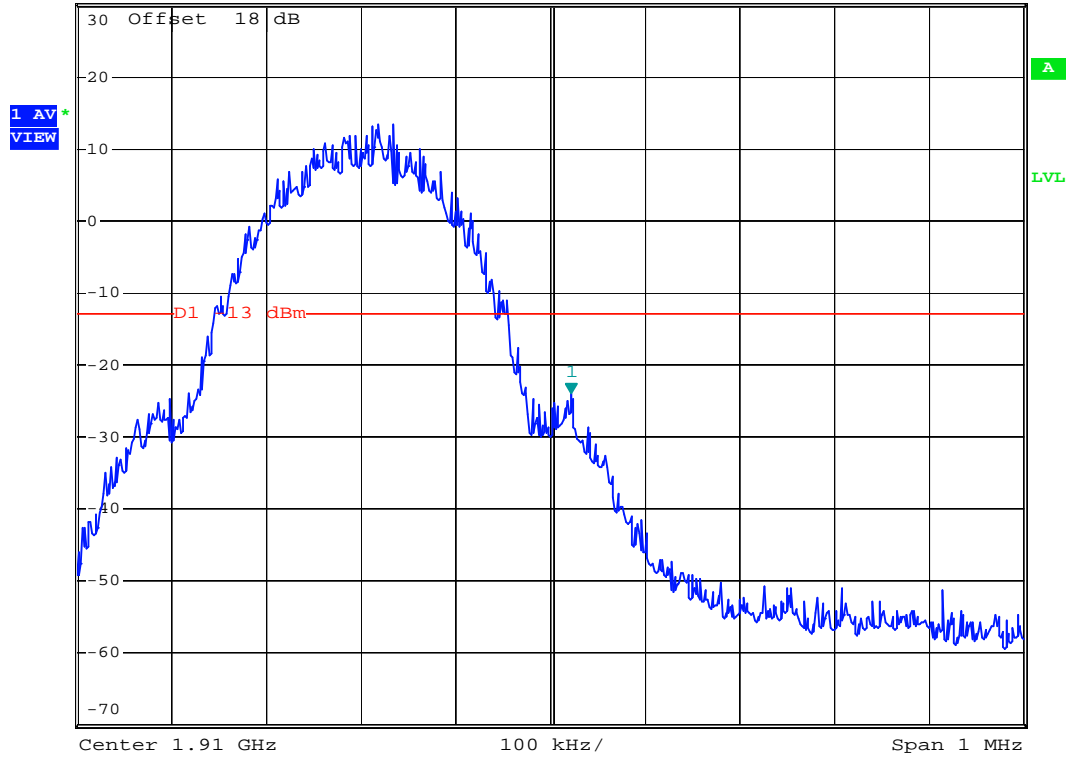

Date: 12.FEB.2007 11:17:34



Ref 30 dBm * Att 30 dB * RBW 3 kHz Marker 1 [T1] -26.38 dBm
* VBW 10 kHz 1.910016026 GHz
* SWT 300 ms

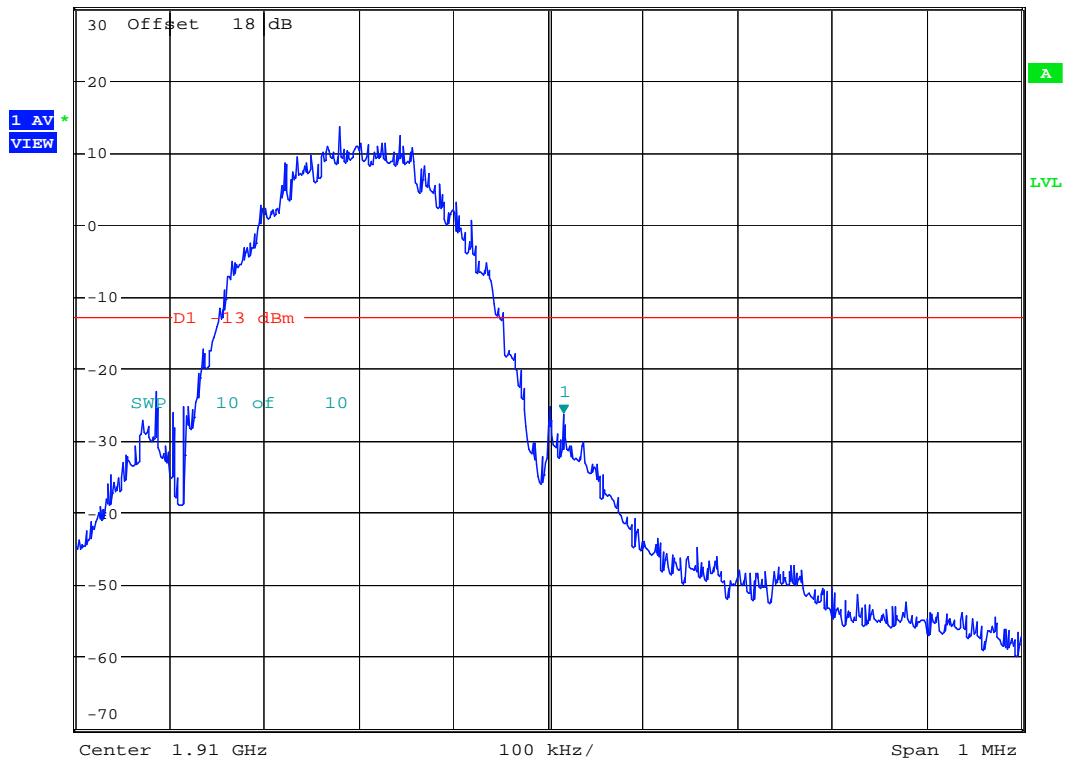

Date: 28.MAR.2007 13:39:25

4.5 Conducted Emission

4.5.1 Measurement Instruments

As described in chapter 5 of this test report.

4.5.2 Test Procedure

1. The EUT was connected to Spectrum Analyzer and Base Station via power divider.
2. The middle channel for the highest RF power within the transmitting frequency was measured.
3. The conducted spurious emission for the whole frequency range was taken.

4.5.3 Test Setup Layout

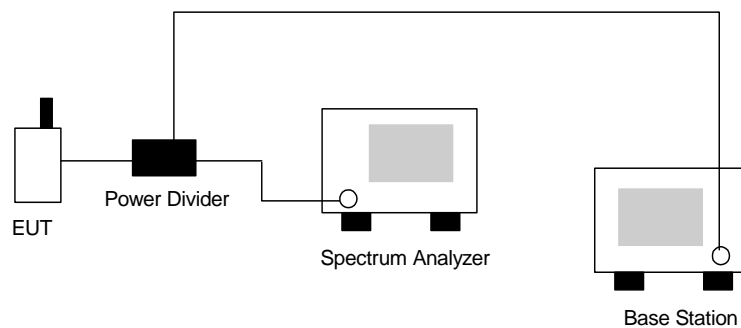



4.5.4 Test Result

- Mode 1
- Test Mode : GSM850 (GSM) CH189
- Frequency Range : 30M-1G

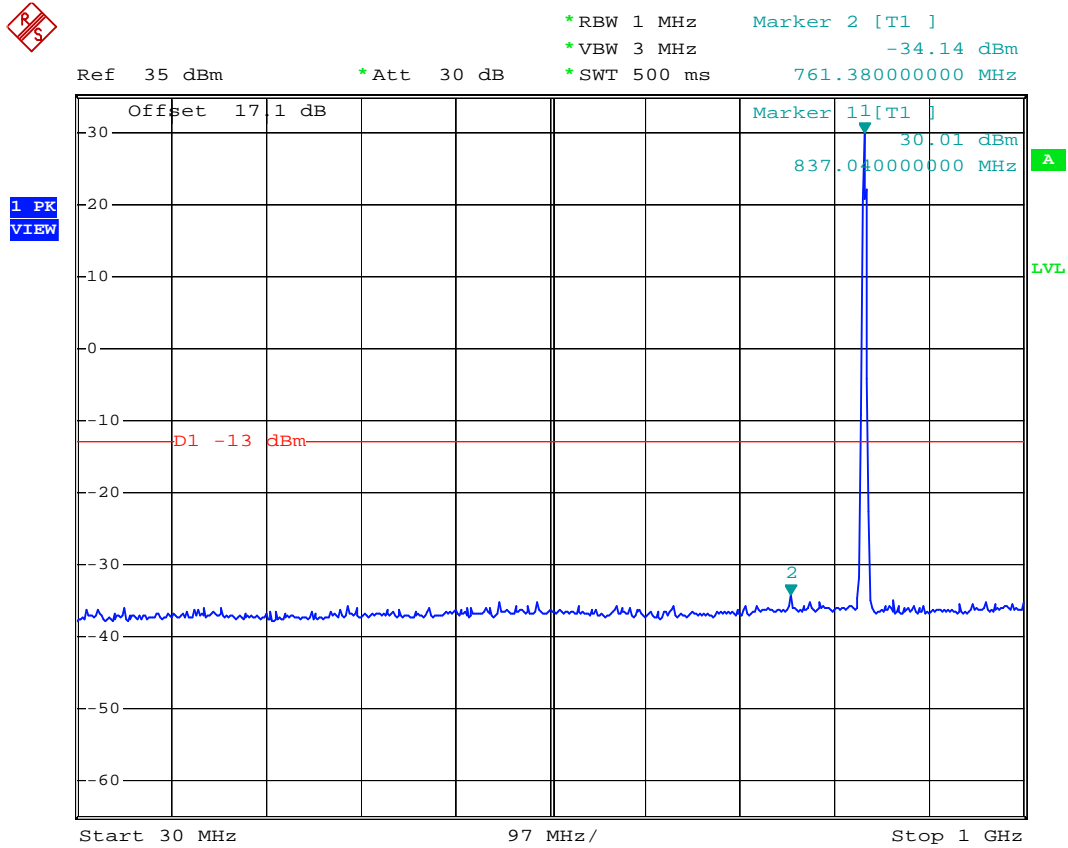

Date: 1.DEC.2006 16:23:50



- Test Mode : GSM850 (GSM) CH189
- Frequency Range : 1G-3G

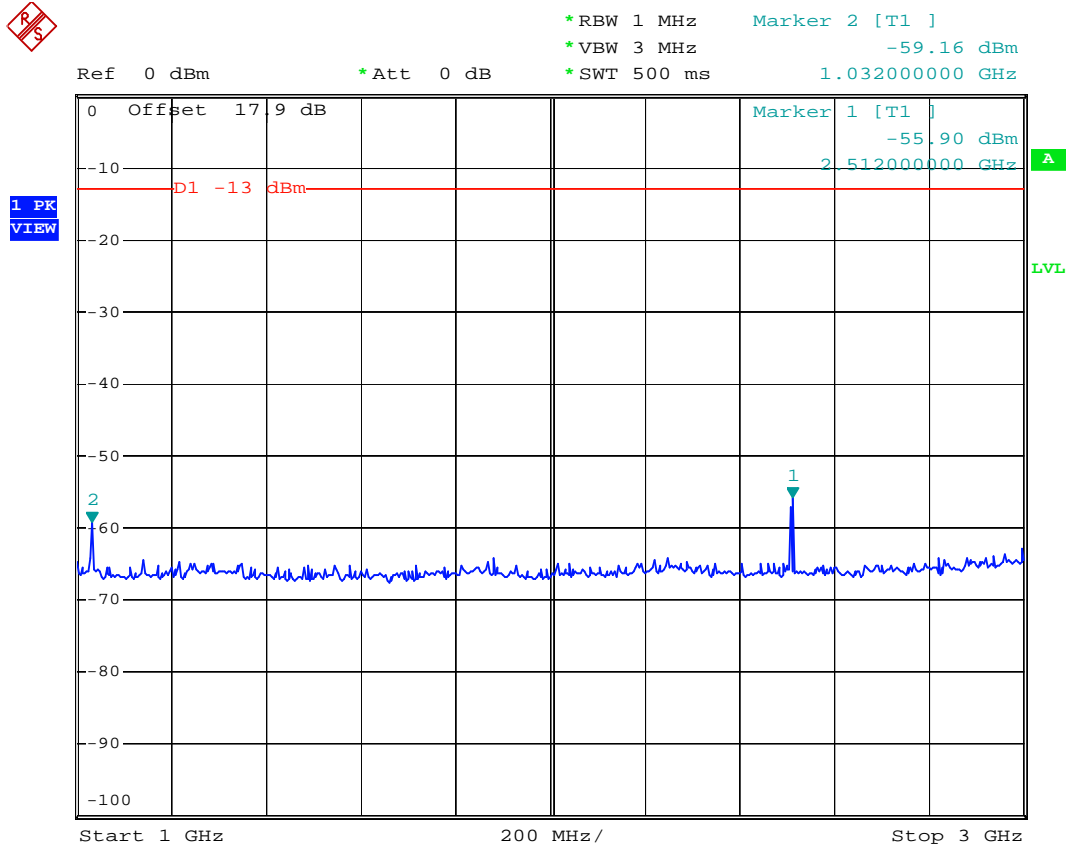

Date: 1.DEC.2006 16:28:46



- Test Mode : GSM850 (GSM) CH189
- Frequency Range : 3G-7G

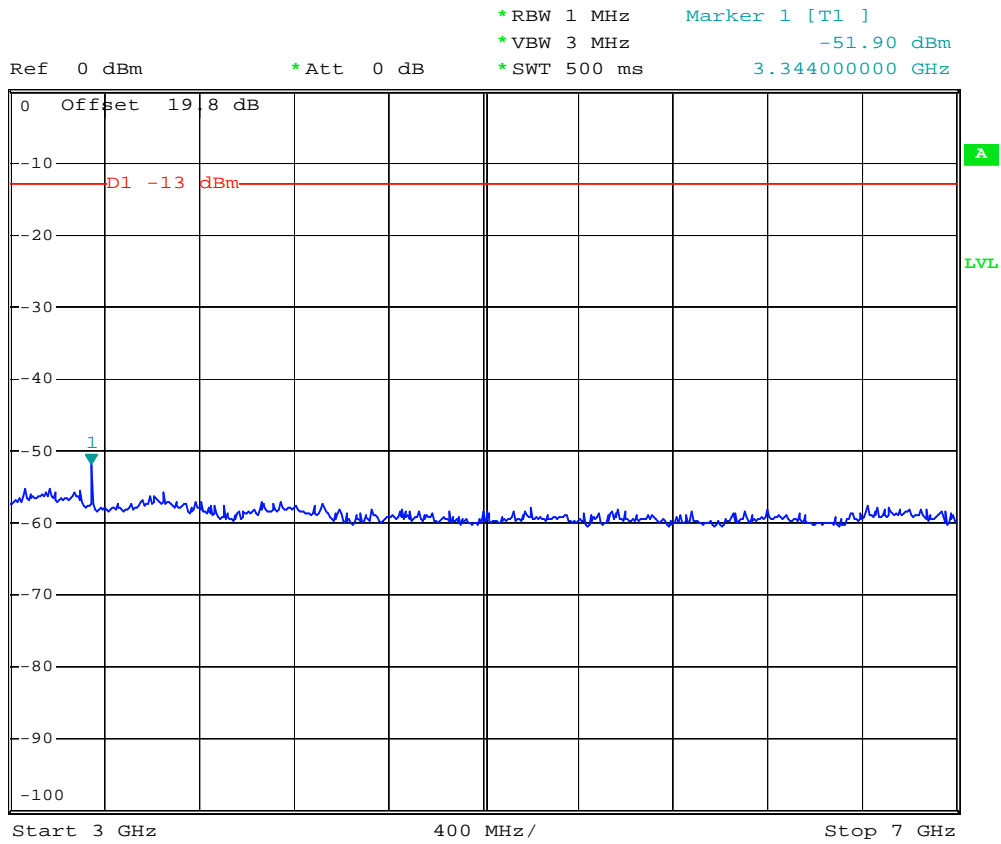

Date: 1.DEC.2006 16:30:30



- Test Mode : GSM850 (GSM) CH189
- Frequency Range : 7G-9G

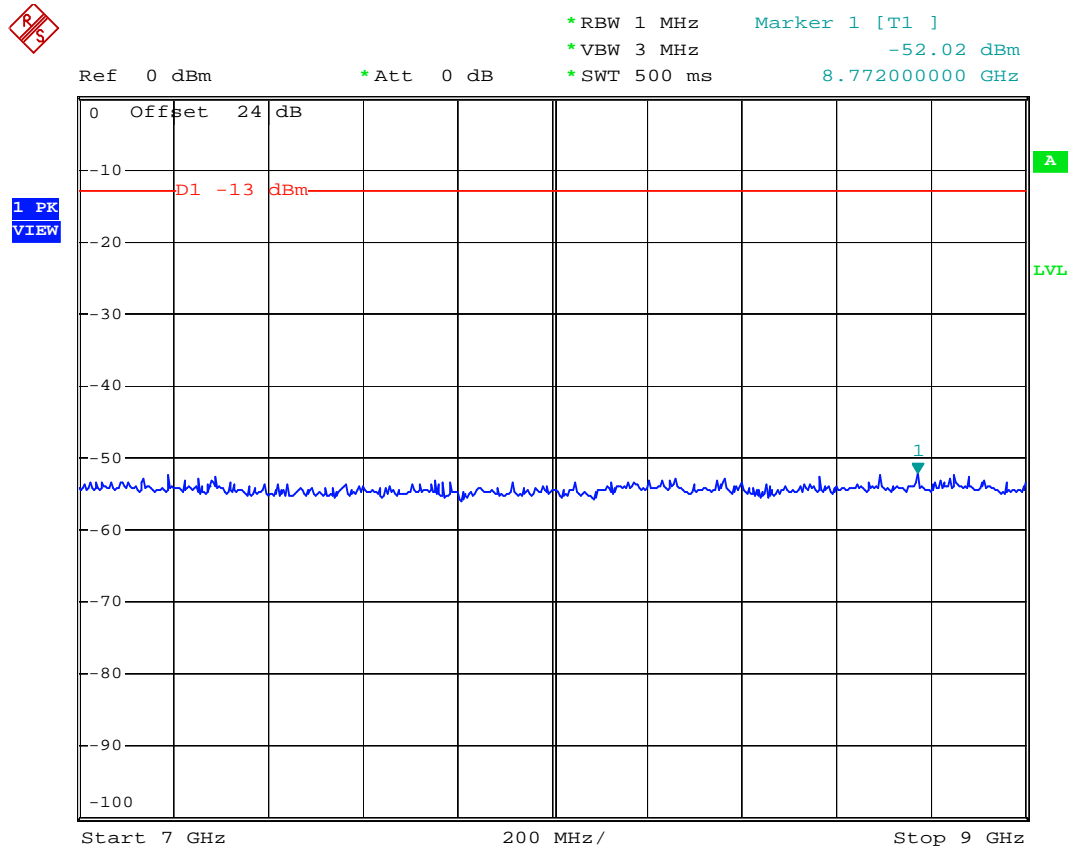

Date: 1.DEC.2006 16:31:44



- Mode 2
- Test Mode : GSM850 (EDGE) CH189
- Frequency Range : 30M-1G

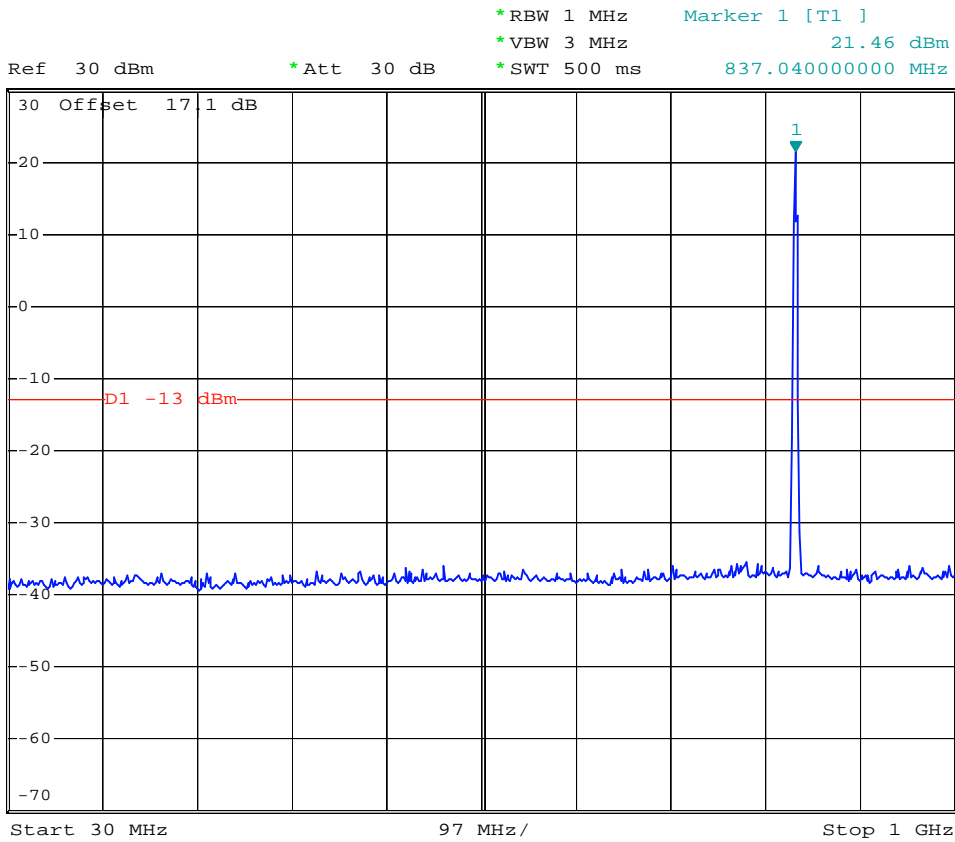

Date: 7.FEB.2007 15:08:27



- Test Mode : GSM850 (EDGE) CH189
- Frequency Range : 1G-3G

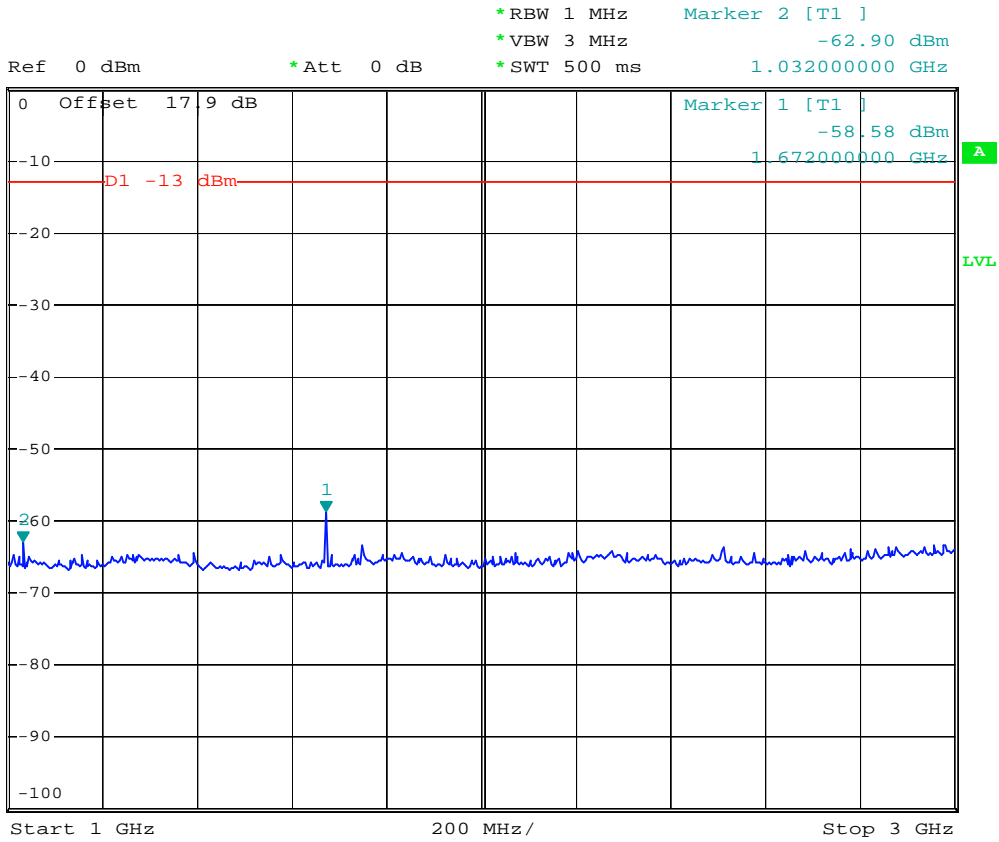

Date: 7.FEB.2007 15:13:49



- Test Mode : GSM850 (EDGE) CH189
- Frequency Range : 3G-7G

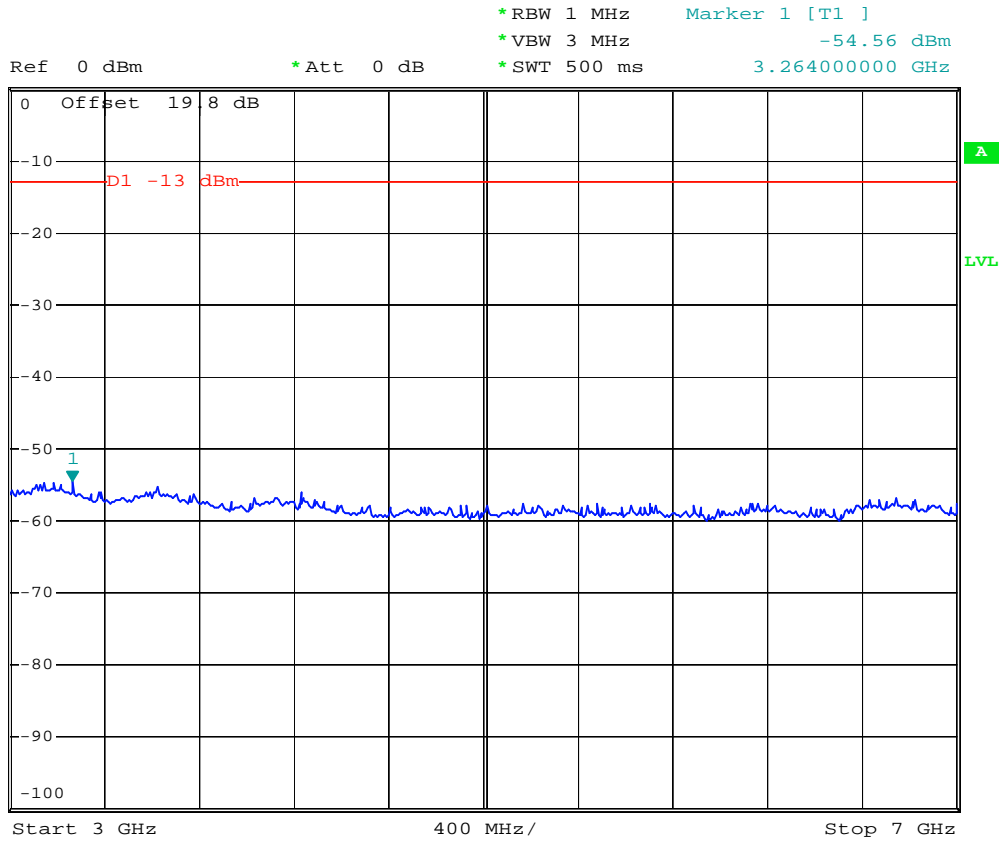

Date: 7.FEB.2007 15:15:31



- Test Mode : GSM850 (EDGE) CH189
- Frequency Range : 7G-9G

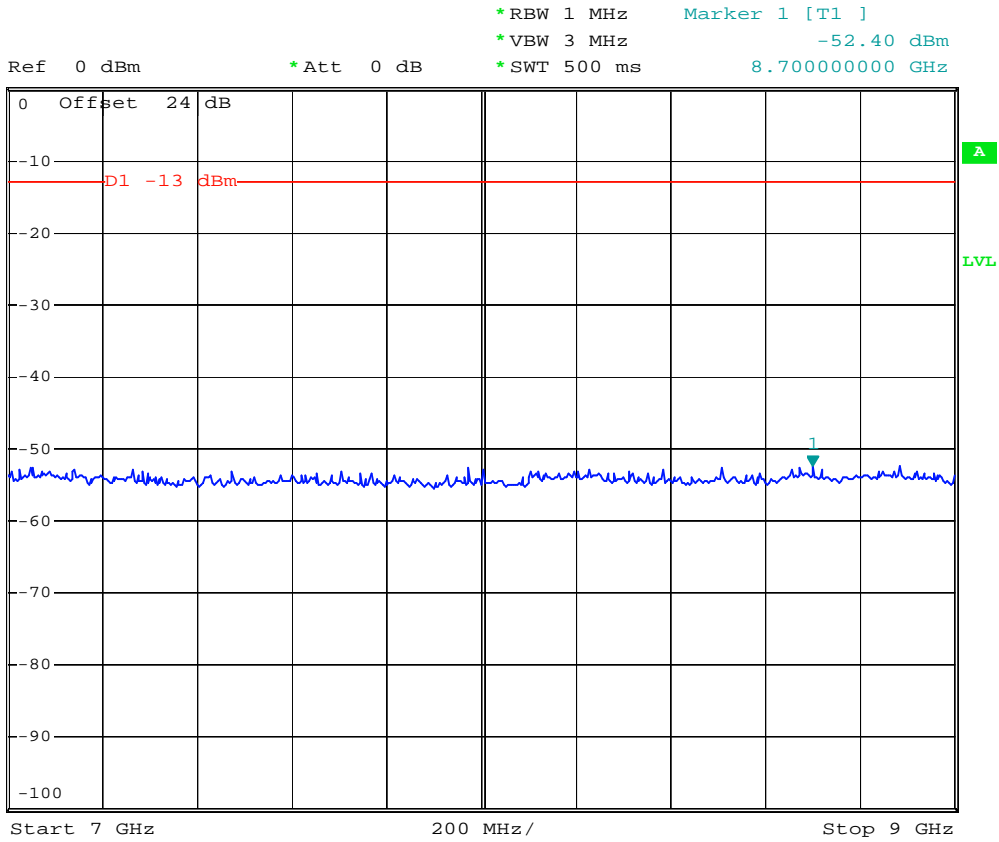

Date: 7.FEB.2007 15:18:03



- Mode 3
- Test Mode : PCS1900 (GSM) CH661
- Frequency Range : 30M-1G



Ref 30 dBm * Att 30 dB * RBW 1 MHz Marker 1 [T1]
* VBW 3 MHz -31.28 dBm
* SWT 500 ms 111.48000000 MHz

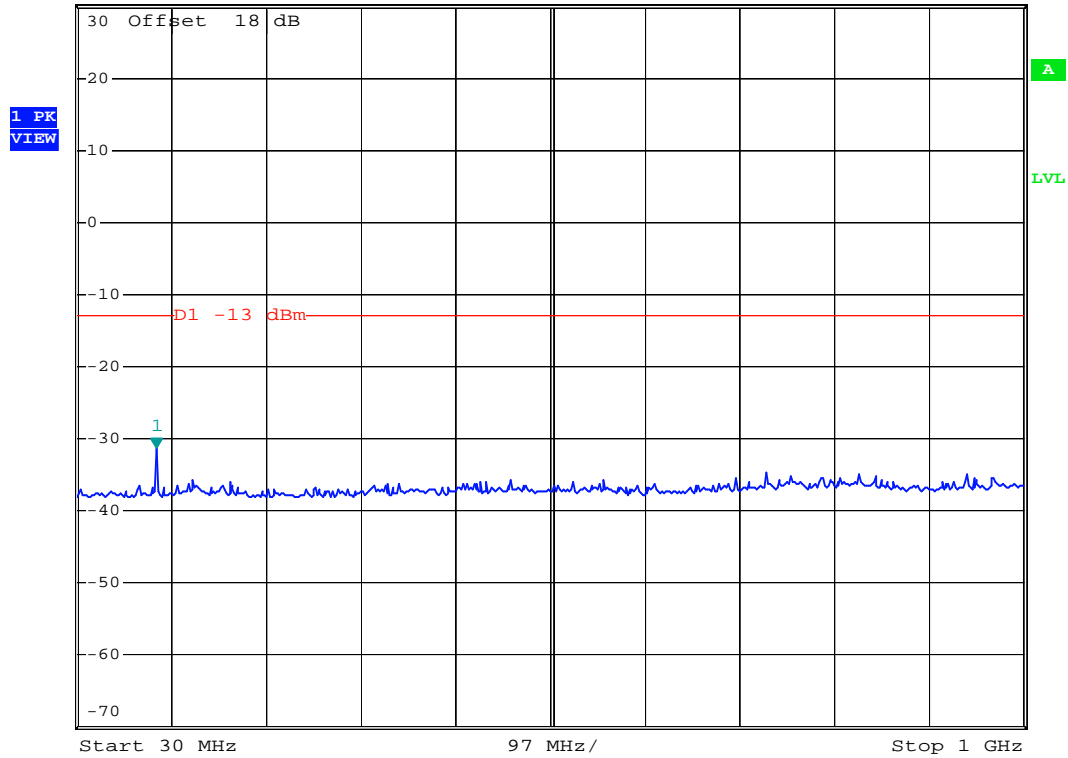

Date: 1.DEC.2006 16:55:15



- Test Mode : PCS1900 (GSM) CH661
- Frequency Range : 1G-3G

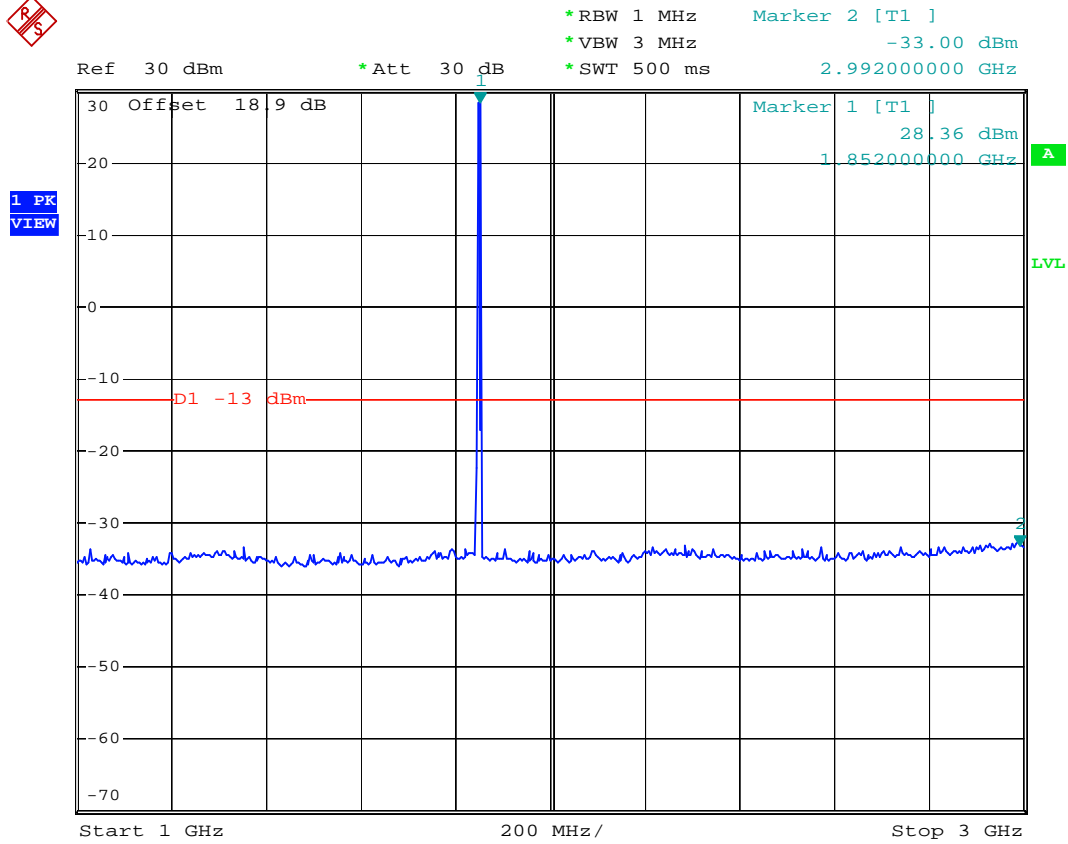

Date: 1.DEC.2006 16:56:59



- Test Mode : PCS1900 (GSM) CH661
- Frequency Range : 3G-7G

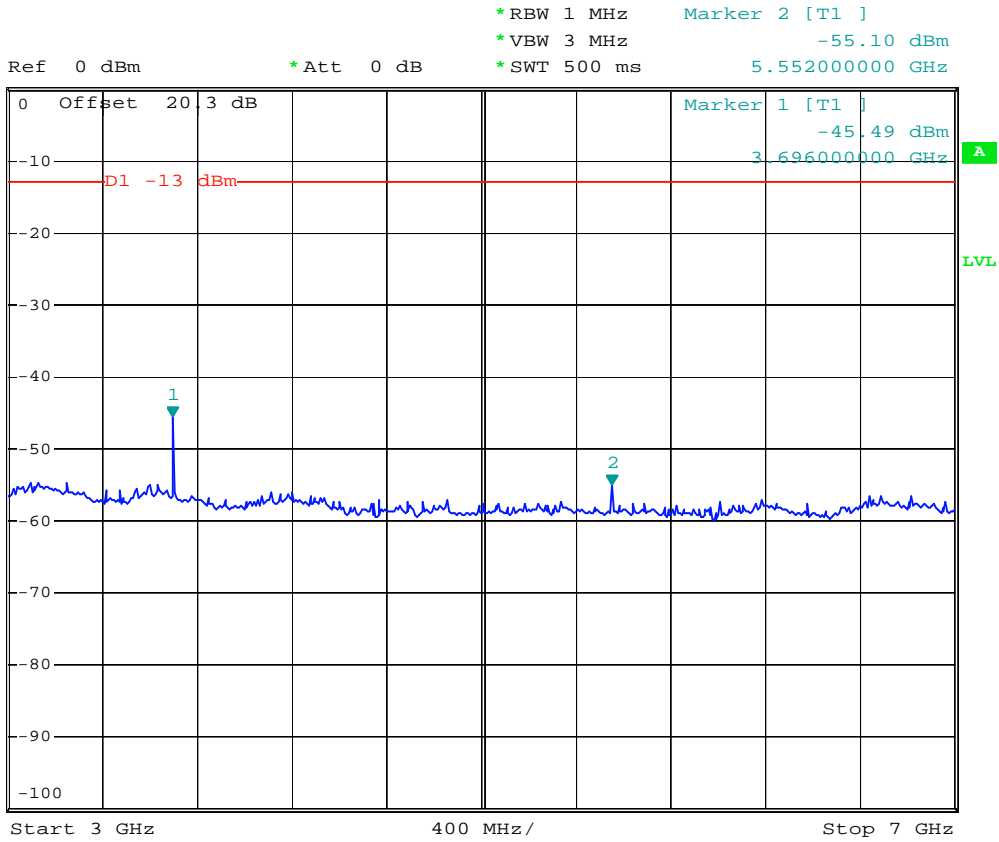

Date: 1.DEC.2006 16:58:53



- Test Mode : PCS1900 (GSM) CH661
- Frequency Range : 7G-13.6G

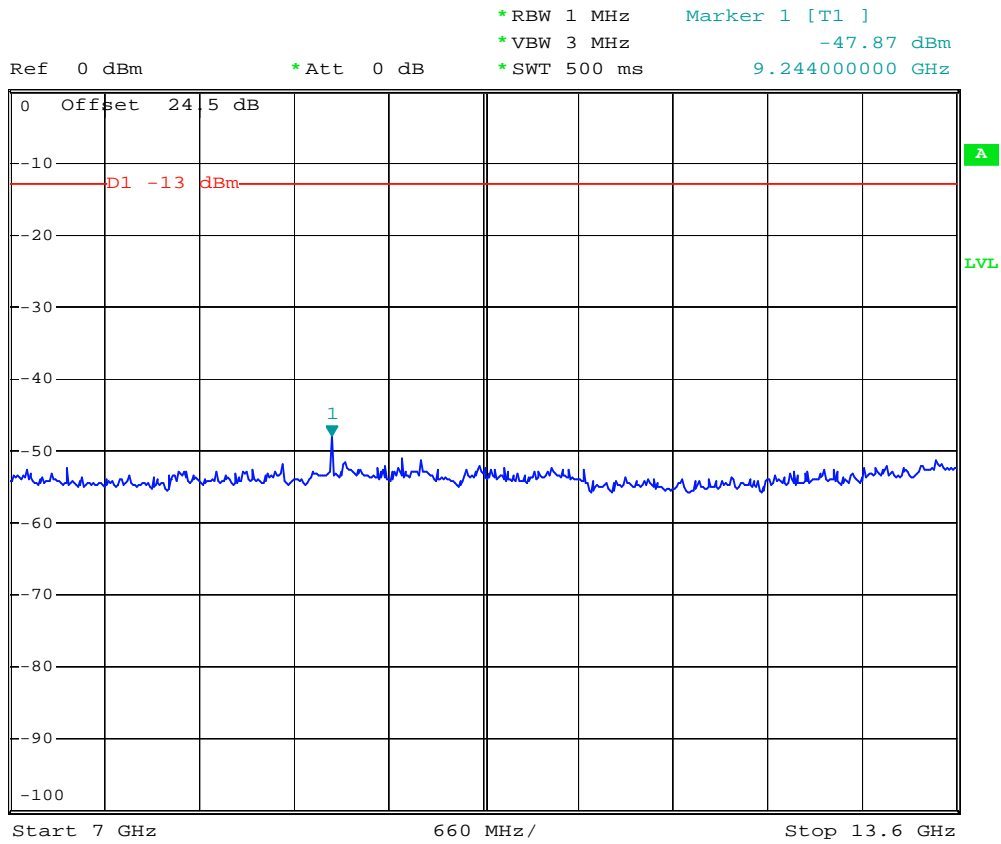

Date: 1.DEC.2006 17:04:34



- Test Mode : PCS1900 (GSM) CH661
- Frequency Range : 13.6G-19.1G

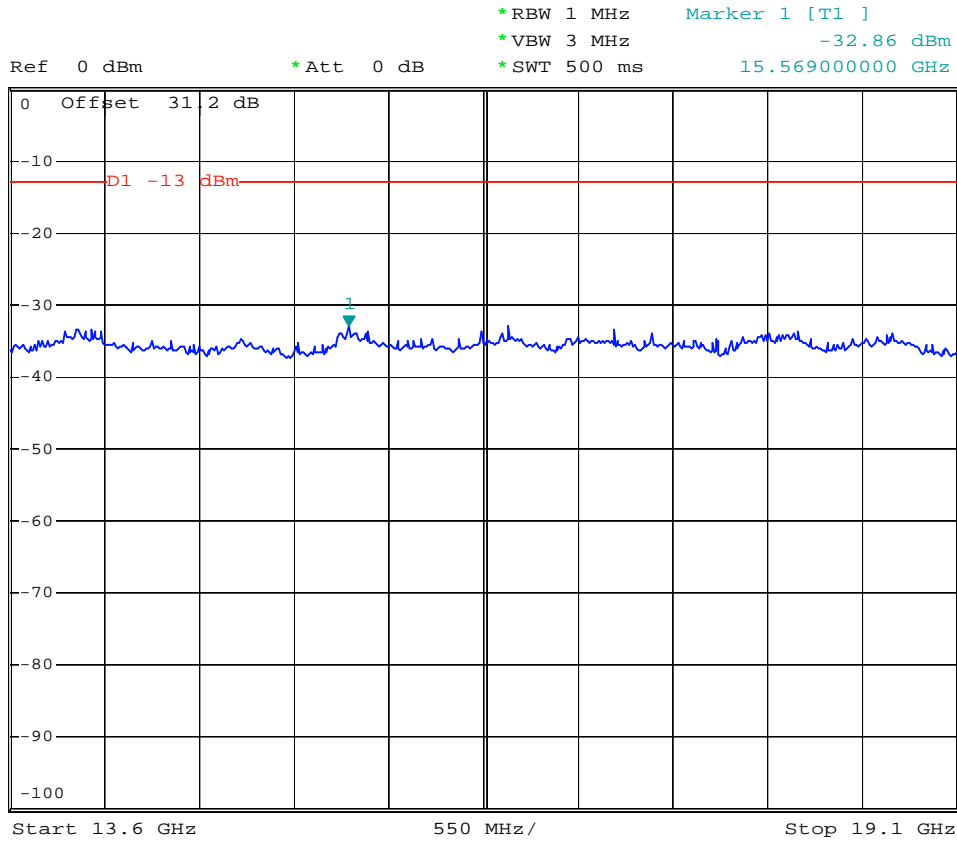

Date: 1.DEC.2006 17:06:29



- Mode 4
- Test Mode : PCS1900 (EDGE) CH661
- Frequency Range : 30M-1G



*RBW 1 MHz Marker 1 [T1]
 *VBW 3 MHz -27.97 dBm
 *SWT 500 ms 140.58000000 MHz

Ref 30 dBm

*Att 30 dB

1 PK VIEW

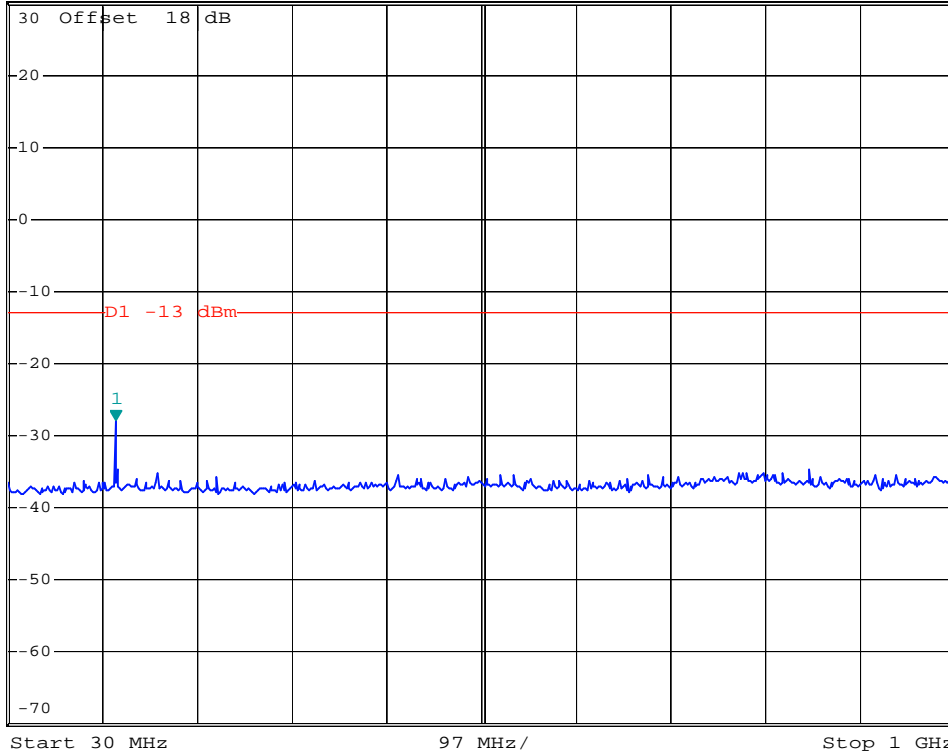

Date: 7.FEB.2007 19:28:56



- Test Mode : PCS1900 (EDGE) CH661
- Frequency Range : 1G-3G

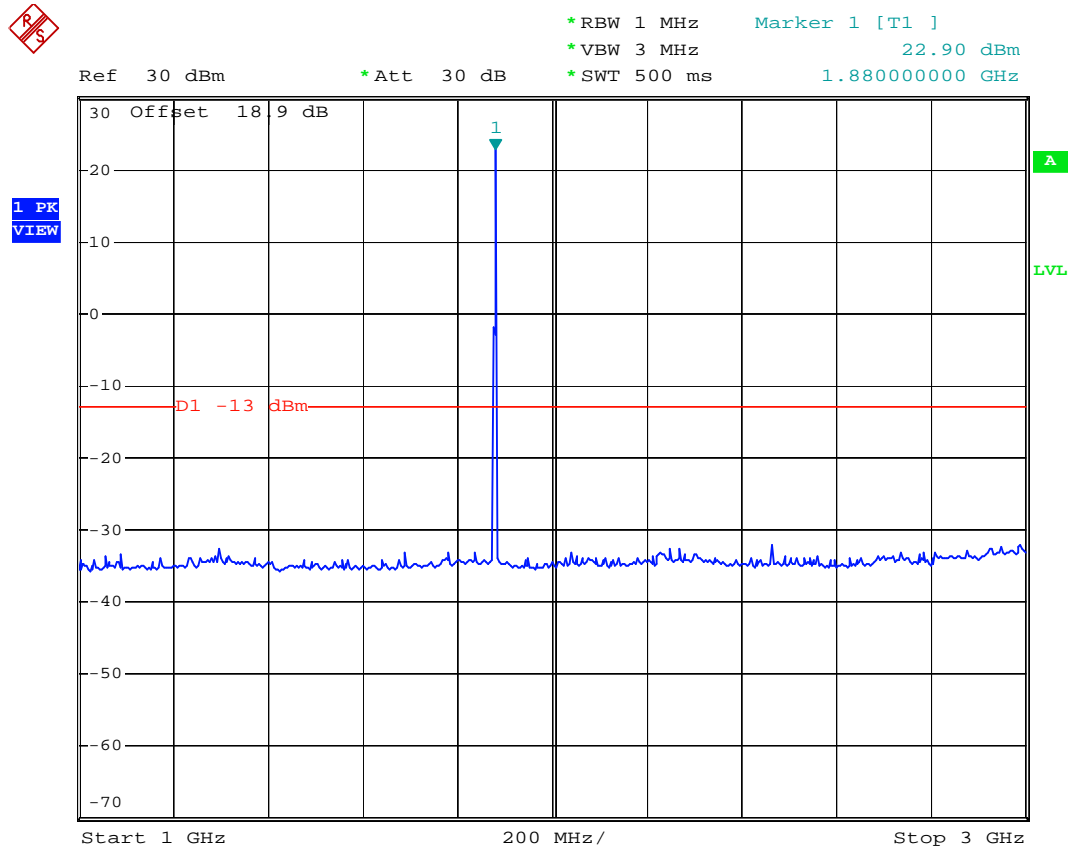

Date: 9.FEB.2007 14:48:31



- Test Mode : PCS1900 (EDGE) CH661
- Frequency Range : 3G-7G

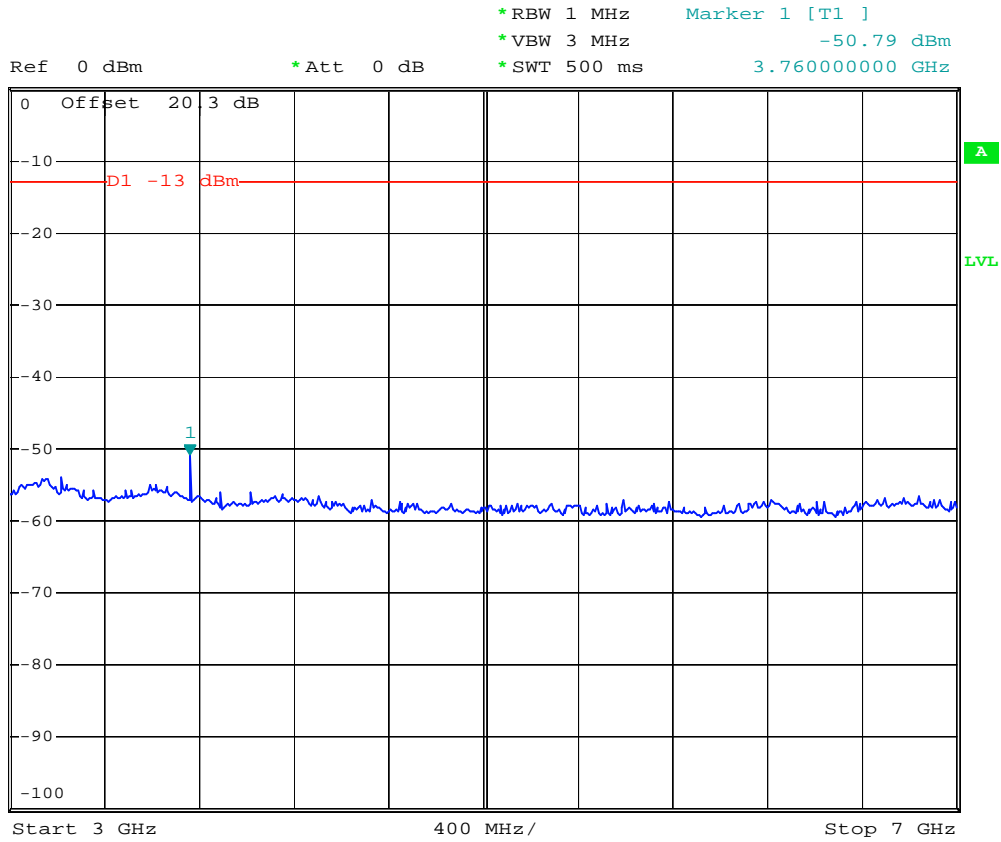

Date: 7.FEB.2007 19:41:20



- Test Mode : PCS1900 (EDGE) CH661
- Frequency Range : 7G-13.6G

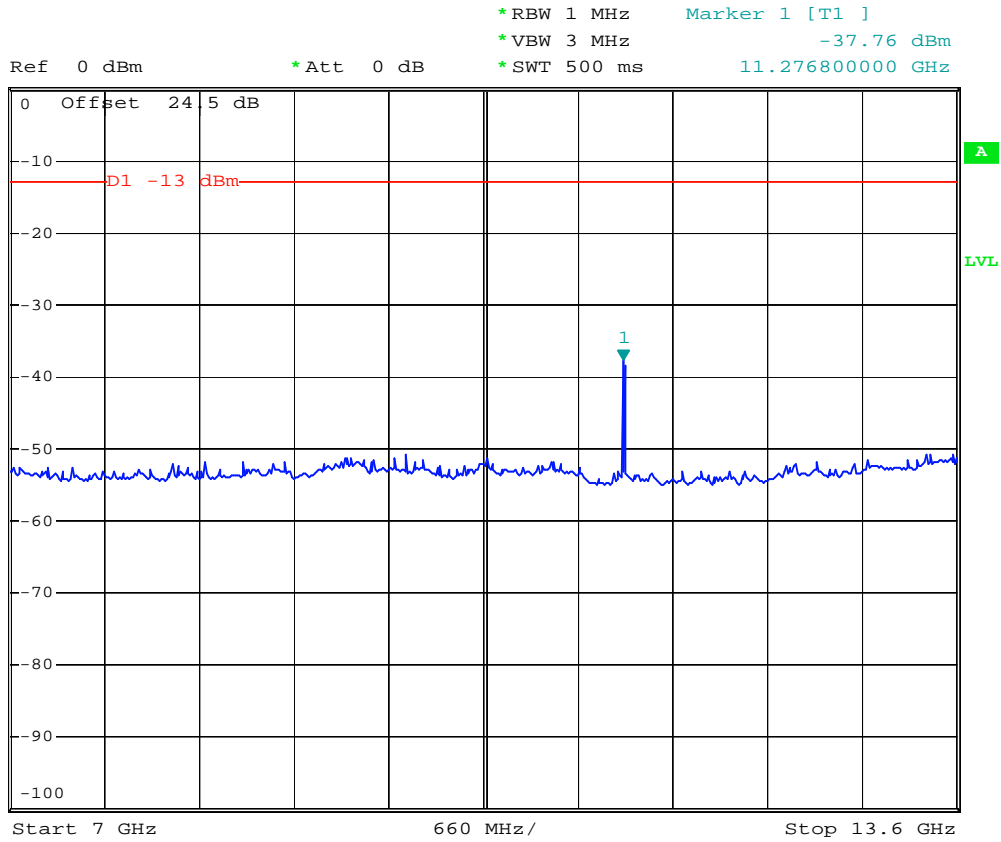

Date: 7.FEB.2007 19:43:12



- Test Mode : PCS1900 (EDGE) CH661
- Frequency Range : 13.6G-19.1G

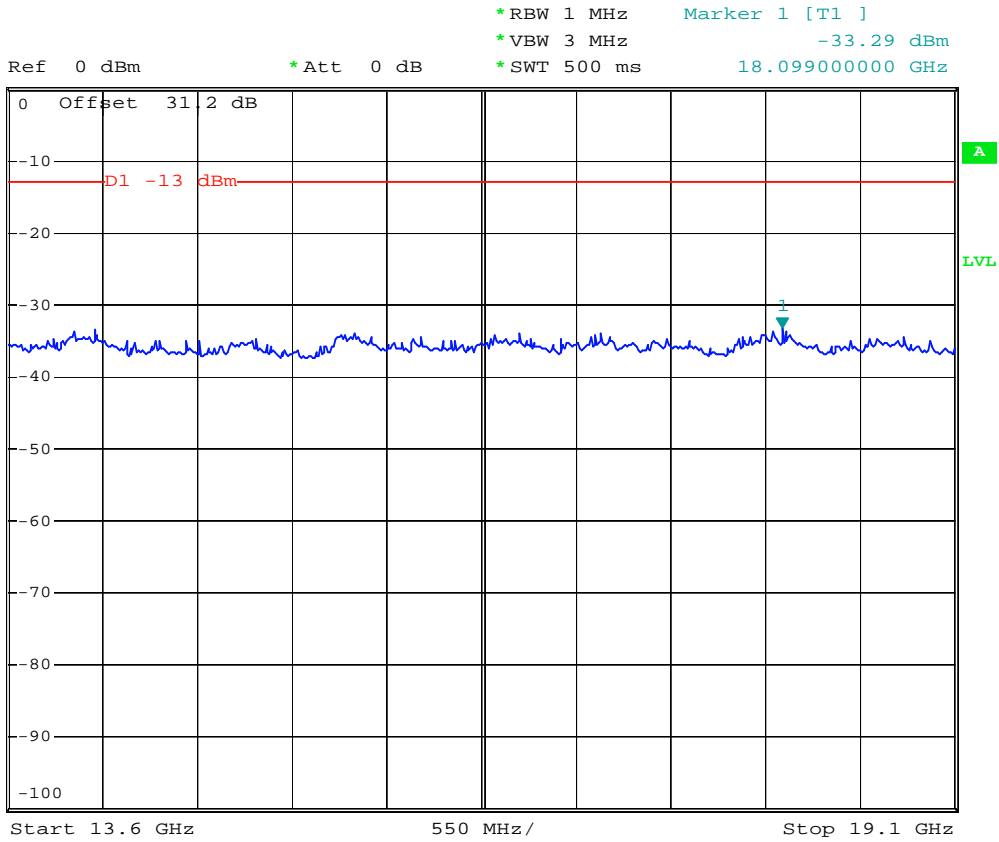

Date: 7.FEB.2007 19:44:50

4.6 Field Strength of Spurious Radiation

Equivalent isotropic radiated Power Measurements by substitution method according to ANSI/TIA/EIA-603-C.

4.6.1 Measurement Instruments

As described in chapter 5 of this test report.

4.6.2 Test Procedure

1. The EUT was placed on a rotatable wooden table with 0.8 meter about ground.
2. The EUT was set 3 meters from the receiving antenna which was mounted on the antenna tower.
3. The table was rotated 360 degrees to determine the position of the highest spurious emission.
4. The height of the receiving antenna is varied between one meter and four meters to reach the maximum spurious emission for both horizontal and vertical polarizations.
5. Taking the record of maximum spurious emission.
6. A Horn antenna was substituted in place of the EUT and was driven by a signal generator.
7. Tune the output power of signal generator to the same emission level with EUT maximum spurious emission.
8. Taking the record of output power at antenna port.
9. Repeat step 7 to step 8 for another polarization.
10. Emission level (dBm) = output power + substitution Gain.

4.6.3 Test Setup Layout

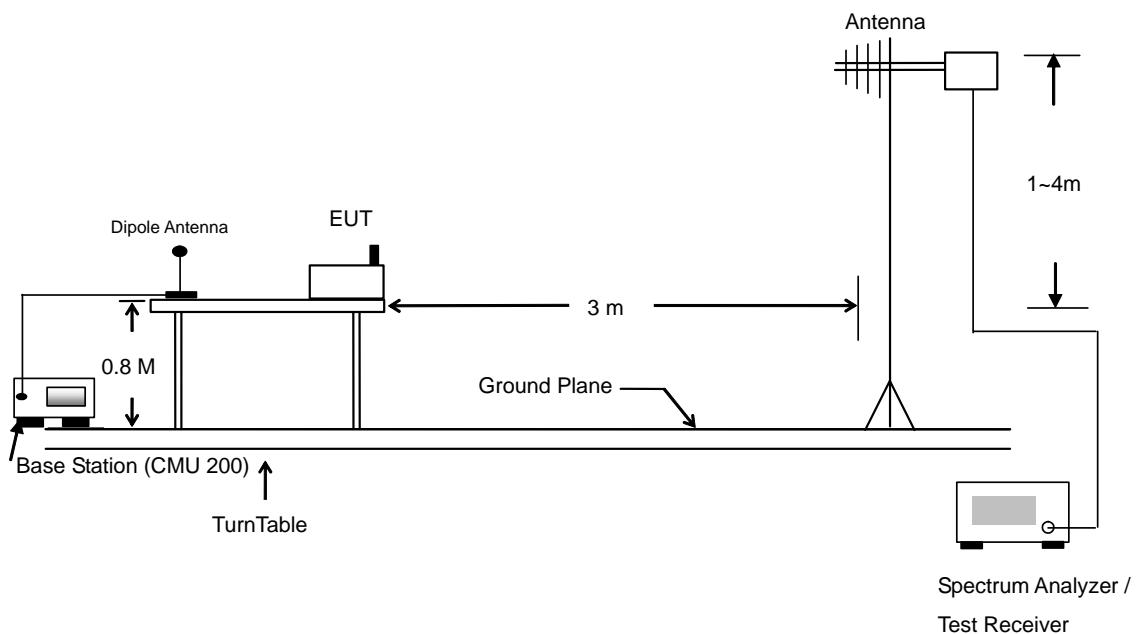



4.6.4 Test Result

- Test Mode : Mode 1

GSM850 (GSM) Radiated Spurious ERP for 7527C							
H Polarization				V Polarization			
Frequency (MHz)	ERP (dBm)	Limit (dBm)	Margin (dB)	Frequency (MHz)	ERP (dBm)	Limit (dBm)	Margin (dB)
33.780	-52.260	-13	-39.26	34.590	-40.360	-13	-27.36
146.640	-51.830	-13	-38.83	154.740	-46.010	-13	-33.01
225.480	-44.650	-13	-31.65	226.290	-40.380	-13	-27.38
402.900	-56.560	-13	-43.56	623.400	-56.420	-13	-43.42
1674.000	-37.210	-13	-24.21	1674.000	-34.020	-13	-21.02
2508.000	-47.230	-13	-34.23	2508.000	-45.820	-13	-32.82
3344.000	-33.790	-13	-20.79	3344.000	-38.020	-13	-25.02
4184.000	-50.030	-13	-37.03	3498.000	-54.940	-13	-41.94
5018.000	-52.250	-13	-39.25	3524.000	-53.370	-13	-40.37
				3578.000	-54.680	-13	-41.68
				3664.000	-55.360	-13	-42.36
				5018.000	-51.790	-13	-38.79
				5854.000	-53.810	-13	-40.81

- Test Mode : Mode 2

GSM850 (EDGE) Radiated Spurious ERP for 7527C							
H Polarization				V Polarization			
Frequency (MHz)	ERP (dBm)	Limit (dBm)	Margin (dB)	Frequency (MHz)	ERP (dBm)	Limit (dBm)	Margin (dB)
33.240	-50.480	-13	-37.48	33.240	-38.120	-13	-25.12
145.290	-50.900	-13	-37.90	82.380	-46.500	-13	-33.50
238.440	-45.560	-13	-32.56	237.630	-42.160	-13	-29.16
995.800	-50.140	-13	-37.14	995.800	-57.070	-13	-44.07
1000.000	-54.880	-13	-41.88	1674.000	-52.040	-13	-39.04
1034.000	-55.680	-13	-42.68	2508.000	-47.110	-13	-34.11
1674.000	-49.390	-13	-36.39	4184.000	-55.470	-13	-42.47
2508.000	-46.680	-13	-33.68				



- Test Mode : Mode 3

PCS1900 (GSM) Radiated Spurious EIRP for 7527C							
H Polarization				V Polarization			
Frequency (MHz)	EIRP (dBm)	Limit (dBm)	Margin (dB)	Frequency (MHz)	EIRP (dBm)	Limit (dBm)	Margin (dB)
70.230	-57.660	-13	-44.66	44.580	-52.440	-13	-39.44
204.690	-58.770	-13	-45.77	95.880	-57.330	-13	-44.33
298.380	-47.580	-13	-34.58	299.190	-48.070	-13	-35.07
308.400	-44.500	-13	-31.50	304.900	-48.430	-13	-35.43
519.800	-57.360	-13	-44.36	519.800	-54.700	-13	-41.70
623.400	-56.790	-13	-43.79	623.400	-51.810	-13	-38.81
1718.000	-46.480	-13	-33.48	1718.000	-51.080	-13	-38.08
3758.000	-43.780	-13	-30.78	3758.000	-53.370	-13	-40.37
5638.000	-51.250	-13	-38.25	5638.000	-48.160	-13	-35.16
				7518.000	-32.280	-13	-19.28

- Test Mode : Mode 4

PCS1900 (EDGE) Radiated Spurious EIRP for 7527C							
H Polarization				V Polarization			
Frequency (MHz)	EIRP (dBm)	Limit (dBm)	Margin (dB)	Frequency (MHz)	EIRP (dBm)	Limit (dBm)	Margin (dB)
39.180	-54.510	-13	-41.51	40.530	-50.590	-13	-37.59
112.080	-50.650	-13	-37.65	79.680	-49.120	-13	-36.12
145.290	-53.410	-13	-40.41	145.830	-49.390	-13	-36.39
449.800	-63.830	-13	-50.83	376.300	-61.220	-13	-48.22
831.300	-64.230	-13	-51.23	453.300	-62.860	-13	-49.86
962.900	-63.650	-13	-50.65	995.800	-61.280	-13	-48.28
1634.000	-58.380	-13	-45.38	1718.000	-49.640	-13	-36.64
1698.000	-54.980	-13	-41.98	3758.000	-42.390	-13	-29.39
1718.000	-46.500	-13	-33.50	5638.000	-46.760	-13	-33.76
3758.000	-46.020	-13	-33.02	7518.000	-43.640	-13	-30.64
5638.000	-45.670	-13	-32.67	11278.000	-42.250	-13	-29.25
7518.000	-38.370	-13	-25.37				
11278.000	-41.430	-13	-28.43				



- Test Mode : Mode 5

GSM850 (GSM) Radiated Spurious ERP for 7527S							
H Polarization				V Polarization			
Frequency (MHz)	ERP (dBm)	Limit (dBm)	Margin (dB)	Frequency (MHz)	ERP (dBm)	Limit (dBm)	Margin (dB)
33.780	-46.260	-13	-33.26	33.780	-36.170	-13	-23.17
144.480	-45.380	-13	-32.38	130.440	-47.230	-13	-34.23
219.540	-40.470	-13	-27.47	220.080	-38.620	-13	-25.62
444.900	-52.280	-13	-39.28	439.300	-51.090	-13	-38.09
1674.000	-40.150	-13	-27.15	1634.000	-56.890	-13	-43.89
2508.000	-46.810	-13	-33.81	1674.000	-43.100	-13	-30.10
				2508.000	-44.960	-13	-31.96

- Test Mode : Mode 6

GSM850 (EDGE) Radiated Spurious ERP for 7527S							
H Polarization				V Polarization			
Frequency (MHz)	ERP (dBm)	Limit (dBm)	Margin (dB)	Frequency (MHz)	ERP (dBm)	Limit (dBm)	Margin (dB)
39.180	-57.350	-13	-44.35	40.530	-52.810	-13	-39.81
123.690	-58.670	-13	-45.67	81.840	-48.960	-13	-35.96
141.780	-55.480	-13	-42.48	103.980	-42.890	-13	-29.89
179.040	-57.810	-13	-44.81	143.130	-47.540	-13	-34.54
516.300	-58.150	-13	-45.15	521.900	-59.730	-13	-46.73
675.900	-60.450	-13	-47.45	675.900	-61.220	-13	-48.22
995.800	-53.810	-13	-40.81	995.800	-58.100	-13	-45.10
1674.000	-36.510	-13	-23.51	1674.000	-37.470	-13	-24.47
2508.000	-39.650	-13	-26.65	2508.000	-40.970	-13	-27.97



- Test Mode : Mode 7

PCS1900 (GSM) Radiated Spurious EIRP for 7527S							
H Polarization				V Polarization			
Frequency (MHz)	EIRP (dBm)	Limit (dBm)	Margin (dB)	Frequency (MHz)	EIRP (dBm)	Limit (dBm)	Margin (dB)
81.030	-55.400	-13	-42.40	65.640	-53.350	-13	-40.35
99.930	-60.380	-13	-47.38	149.880	-46.880	-13	-33.88
148.530	-58.660	-13	-45.66	178.230	-53.390	-13	-40.39
402.900	-50.390	-13	-37.39	437.900	-50.930	-13	-37.93
439.300	-48.150	-13	-35.15	519.800	-58.120	-13	-45.12
519.800	-54.250	-13	-41.25	623.400	-57.480	-13	-44.48
1718.000	-47.280	-13	-34.28	1718.000	-52.470	-13	-39.47
3758.000	-45.920	-13	-32.92	3758.000	-43.630	-13	-30.63
5638.000	-48.780	-13	-35.78	5638.000	-51.580	-13	-38.58
				11278.000	-43.310	-13	-30.31

- Test Mode : Mode 8

PCS1900 (EDGE) Radiated Spurious EIRP for 7527S							
H Polarization				V Polarization			
Frequency (MHz)	EIRP (dBm)	Limit (dBm)	Margin (dB)	Frequency (MHz)	EIRP (dBm)	Limit (dBm)	Margin (dB)
80.490	-56.450	-13	-43.45	81.030	-48.870	-13	-35.87
125.040	-53.540	-13	-40.54	120.990	-48.570	-13	-35.57
147.180	-56.570	-13	-43.57	146.640	-49.920	-13	-36.92
831.300	-63.540	-13	-50.54	327.300	-60.550	-13	-47.55
917.400	-64.580	-13	-51.58	442.800	-63.700	-13	-50.70
978.300	-63.940	-13	-50.94	519.800	-63.060	-13	-50.06
1718.000	-48.920	-13	-35.92	1718.000	-55.940	-13	-42.94
3758.000	-35.720	-13	-22.72	1738.000	-53.980	-13	-40.98
5638.000	-41.410	-13	-28.41	3758.000	-34.380	-13	-21.38
5638.000	-37.120	-13	-24.12				



- Test Mode : Mode 9

GSM850 (GSM) with Bluetooth and WLAN (802.11b/g) Co-location Radiated Spurious EIRP for 7527C							
H Polarization				V Polarization			
Frequency (MHz)	EIRP (dBm)	Limit (dBm)	Margin (dB)	Frequency (MHz)	EIRP (dBm)	Limit (dBm)	Margin (dB)
33.780	-55.560	-13	-42.56	33.240	-43.810	-13	-30.81
224.130	-53.140	-13	-40.14	152.040	-46.100	-13	-33.10
299.190	-49.750	-13	-36.75	224.940	-48.180	-13	-35.18
309.800	-46.640	-13	-33.64	313.300	-49.880	-13	-36.88
836.900	-43.360	-13	-30.36	836.900	-45.220	-13	-32.22
880.300	-42.210	-13	-29.21	1574.000	-39.500	-13	-26.50
1000.000	-54.840	-13	-41.84	1674.000	-48.230	-13	-35.23
1034.000	-55.170	-13	-42.17	2204.000	-46.150	-13	-33.15
1574.000	-39.490	-13	-26.49	2508.000	-48.100	-13	-35.10
1674.000	-50.290	-13	-37.29	2618.000	-33.410	-13	-20.41
2204.000	-48.260	-13	-35.26	3248.000	-45.130	-13	-32.13
2508.000	-50.340	-13	-37.34	3344.000	-52.780	-13	-39.78
2614.000	-37.140	-13	-24.14	4818.000	-36.620	-13	-23.62
2764.000	-55.430	-13	-42.43	7234.000	-26.150	-13	-13.15
3248.000	-43.740	-13	-30.74				
3344.000	-49.230	-13	-36.23				
3994.000	-52.010	-13	-39.01				
4824.000	-43.340	-13	-30.34				
7234.000	-41.540	-13	-28.54				

- Test Mode : Mode 10

GSM850 (GSM) + Endcap 1 Radiated Spurious ERP for 7527C							
H Polarization				V Polarization			
Frequency (MHz)	ERP (dBm)	Limit (dBm)	Margin (dB)	Frequency (MHz)	ERP (dBm)	Limit (dBm)	Margin (dB)
32.430	-48.950	-13	-35.95	33.240	-37.860	-13	-24.86
147.180	-53.910	-13	-40.91	148.530	-45.640	-13	-32.64
221.430	-43.040	-13	-30.04	221.430	-42.120	-13	-29.12
995.800	-57.240	-13	-44.24	995.800	-54.170	-13	-41.17
1674.000	-54.250	-13	-41.25	1674.000	-51.550	-13	-38.55
2508.000	-51.560	-13	-38.56	2508.000	-51.140	-13	-38.14



Test Mode : Mode 11

GSM850 (GSM) + Endcap 2 Radiated Spurious ERP for 7527C							
H Polarization				V Polarization			
Frequency (MHz)	ERP (dBm)	Limit (dBm)	Margin (dB)	Frequency (MHz)	ERP (dBm)	Limit (dBm)	Margin (dB)
32.430	-48.960	-13	-35.96	33.240	-39.570	-13	-26.57
145.830	-54.470	-13	-41.47	148.530	-45.570	-13	-32.57
220.890	-44.900	-13	-31.90	220.080	-45.560	-13	-32.56
995.800	-56.830	-13	-43.83	995.800	-53.740	-13	-40.74
1674.000	-52.450	-13	-39.45	1674.000	-53.090	-13	-40.09
2508.000	-52.880	-13	-39.88	2508.000	-52.950	-13	-39.95

Test Mode : Mode 12

GSM850 (GSM) + Endcap 5 Radiated Spurious ERP for 7527C							
H Polarization				V Polarization			
Frequency (MHz)	ERP (dBm)	Limit (dBm)	Margin (dB)	Frequency (MHz)	ERP (dBm)	Limit (dBm)	Margin (dB)
33.240	-52.560	-13	-39.56	32.430	-38.090	-13	-25.09
145.830	-52.340	-13	-39.34	144.480	-45.850	-13	-32.85
220.890	-37.730	-13	-24.73	220.890	-30.320	-13	-17.32
995.800	-52.040	-13	-39.04	995.800	-58.580	-13	-45.58
1674.000	-27.320	-13	-14.32	1674.000	-35.980	-13	-22.98
2508.000	-47.800	-13	-34.80	2508.000	-45.340	-13	-32.34
3344.000	-54.140	-13	-41.14				

Test Mode : Mode 13

GSM850 (GSM) + POD 1 Radiated Spurious ERP for 7527C							
H Polarization				V Polarization			
Frequency (MHz)	ERP (dBm)	Limit (dBm)	Margin (dB)	Frequency (MHz)	ERP (dBm)	Limit (dBm)	Margin (dB)
33.240	-48.810	-13	-35.81	33.240	-38.840	-13	-25.84
147.180	-54.060	-13	-41.06	149.340	-45.510	-13	-32.51
220.080	-44.110	-13	-31.11	221.430	-45.030	-13	-32.03
995.800	-58.020	-13	-45.02	995.800	-54.060	-13	-41.06
1674.000	-51.810	-13	-38.81	1674.000	-55.160	-13	-42.16
2508.000	-51.920	-13	-38.92	2508.000	-54.450	-13	-41.45



- Test Mode : Mode 14

GSM850 (GSM) + POD 2 Radiated Spurious ERP for 7527C							
H Polarization				V Polarization			
Frequency (MHz)	ERP (dBm)	Limit (dBm)	Margin (dB)	Frequency (MHz)	ERP (dBm)	Limit (dBm)	Margin (dB)
33.240	-47.010	-13	-34.01	33.240	-37.730	-13	-24.73
178.230	-55.130	-13	-42.13	153.930	-46.640	-13	-33.64
220.080	-42.330	-13	-29.33	219.540	-41.890	-13	-28.89
995.800	-58.620	-13	-45.62	995.800	-54.200	-13	-41.20
1674.000	-39.360	-13	-26.36	1674.000	-46.760	-13	-33.76
1828.000	-60.550	-13	-47.55	2508.000	-49.960	-13	-36.96
2508.000	-51.420	-13	-38.42	3664.000	-55.490	-13	-42.49

- Test Mode : Mode 15

GSM850 (GSM) + POD 3 Radiated Spurious ERP for 7527C							
H Polarization				V Polarization			
Frequency (MHz)	ERP (dBm)	Limit (dBm)	Margin (dB)	Frequency (MHz)	ERP (dBm)	Limit (dBm)	Margin (dB)
32.430	-47.440	-13	-34.44	33.780	-38.990	-13	-25.99
145.830	-54.630	-13	-41.63	154.740	-46.660	-13	-33.66
220.890	-44.110	-13	-31.11	220.080	-43.930	-13	-30.93
995.800	-56.470	-13	-43.47	995.800	-53.740	-13	-40.74
1674.000	-52.220	-13	-39.22	1124.000	-46.070	-13	-33.07
2508.000	-45.320	-13	-32.32	1674.000	-50.790	-13	-37.79
				2508.000	-48.130	-13	-35.13
				3664.000	-56.140	-13	-43.14
				3706.000	-55.170	-13	-42.17



- Test Mode : Mode 16

GSM850 (GSM) + POD 4 Radiated Spurious ERP for 7527C							
H Polarization				V Polarization			
Frequency (MHz)	ERP (dBm)	Limit (dBm)	Margin (dB)	Frequency (MHz)	ERP (dBm)	Limit (dBm)	Margin (dB)
32.430	-47.290	-13	-34.29	33.240	-40.130	-13	-27.13
145.290	-56.020	-13	-43.02	153.390	-46.470	-13	-33.47
220.890	-42.850	-13	-29.85	220.080	-44.600	-13	-31.60
995.800	-56.470	-13	-43.47	995.800	-54.050	-13	-41.05
1614.000	-55.660	-13	-42.66	1674.000	-54.800	-13	-41.80
1674.000	-47.000	-13	-34.00	2508.000	-47.810	-13	-34.81
2508.000	-44.710	-13	-31.71				

- Test Mode : Mode 17

GSM850 (GSM) + POD 6 Radiated Spurious ERP for 7527C							
H Polarization				V Polarization			
Frequency (MHz)	ERP (dBm)	Limit (dBm)	Margin (dB)	Frequency (MHz)	ERP (dBm)	Limit (dBm)	Margin (dB)
32.430	-47.110	-13	-34.11	33.240	-40.120	-13	-27.12
145.290	-56.380	-13	-43.38	152.580	-46.950	-13	-33.95
220.890	-44.890	-13	-31.89	220.890	-46.150	-13	-33.15
995.800	-57.740	-13	-44.74	995.800	-54.510	-13	-41.51
1674.000	-36.720	-13	-23.72	1674.000	-36.130	-13	-23.13
2508.000	-50.170	-13	-37.17	2508.000	-46.130	-13	-33.13
3344.000	-49.470	-13	-36.47	3344.000	-57.360	-13	-44.36

- Test Mode : Mode 18

GSM850 (EDGE) + Endcap 5 Radiated Spurious ERP for 7527C							
H Polarization				V Polarization			
Frequency (MHz)	ERP (dBm)	Limit (dBm)	Margin (dB)	Frequency (MHz)	ERP (dBm)	Limit (dBm)	Margin (dB)
60.780	-61.560	-13	-48.56	60.240	-53.950	-13	-40.95
143.940	-57.760	-13	-44.76	145.290	-52.420	-13	-39.42
226.830	-58.480	-13	-45.48	152.580	-53.330	-13	-40.33
995.800	-60.640	-13	-47.64	729.800	-56.070	-13	-43.07
1674.000	-47.920	-13	-34.92	1674.000	-58.800	-13	-45.80



- Test Mode : Mode 19

GSM850 (GSM) + Endcap 5 + Pistol Grips Radiated Spurious ERP for 7527C							
H Polarization				V Polarization			
Frequency (MHz)	ERP (dBm)	Limit (dBm)	Margin (dB)	Frequency (MHz)	ERP (dBm)	Limit (dBm)	Margin (dB)
31.890	-51.070	-13	-38.07	33.240	-38.050	-13	-25.05
145.290	-51.250	-13	-38.25	145.290	-45.980	-13	-32.98
220.890	-37.400	-13	-24.40	220.080	-31.170	-13	-18.17
995.800	-51.630	-13	-38.63	995.800	-56.960	-13	-43.96
1674.000	-39.080	-13	-26.08	1674.000	-45.430	-13	-32.43
2508.000	-47.620	-13	-34.62	2508.000	-50.120	-13	-37.12

- Test Mode : Mode 20

PCS1900 (GSM) + Endcap 1 Radiated Spurious EIRP for 7527C							
H Polarization				V Polarization			
Frequency (MHz)	EIRP (dBm)	Limit (dBm)	Margin (dB)	Frequency (MHz)	EIRP (dBm)	Limit (dBm)	Margin (dB)
73.740	-58.100	-13	-45.10	72.390	-51.790	-13	-38.79
133.140	-61.160	-13	-48.16	149.340	-49.460	-13	-36.46
189.840	-60.850	-13	-47.85	188.490	-54.100	-13	-41.10
364.400	-57.110	-13	-44.11	479.900	-59.550	-13	-46.55
852.300	-64.860	-13	-51.86	532.400	-58.980	-13	-45.98
971.300	-63.960	-13	-50.96	570.900	-59.880	-13	-46.88
1718.000	-54.260	-13	-41.26	1718.000	-58.940	-13	-45.94
3758.000	-50.890	-13	-37.89	3758.000	-52.370	-13	-39.37
5638.000	-41.980	-13	-28.98	5638.000	-49.100	-13	-36.10
11278.000	-37.990	-13	-24.99	11278.000	-39.150	-13	-26.15



- Test Mode : Mode 21

PCS1900 (GSM) + Endcap 2 Radiated Spurious EIRP for 7527C							
H Polarization				V Polarization			
Frequency (MHz)	EIRP (dBm)	Limit (dBm)	Margin (dB)	Frequency (MHz)	EIRP (dBm)	Limit (dBm)	Margin (dB)
72.930	-58.270	-13	-45.27	64.290	-53.610	-13	-40.61
83.190	-61.050	-13	-48.05	72.930	-52.330	-13	-39.33
189.030	-61.570	-13	-48.57	148.530	-49.460	-13	-36.46
376.300	-63.940	-13	-50.94	467.300	-58.920	-13	-45.92
519.800	-64.020	-13	-51.02	523.300	-56.370	-13	-43.37
994.400	-63.510	-13	-50.51	553.400	-60.820	-13	-47.82
1718.000	-50.260	-13	-37.26	1018.000	-55.880	-13	-42.88
1898.000	-54.090	-13	-41.09	1454.000	-58.650	-13	-45.65
3758.000	-40.810	-13	-27.81	1528.000	-58.060	-13	-45.06
5638.000	-33.660	-13	-20.66	1664.000	-52.960	-13	-39.96
11278.000	-41.460	-13	-28.46	1718.000	-46.320	-13	-33.32
				1754.000	-44.170	-13	-31.17
				3758.000	-42.560	-13	-29.56
				5638.000	-50.500	-13	-37.50
				11278.000	-41.380	-13	-28.38

- Test Mode : Mode 22

PCS1900 (GSM) + Endcap 5 Radiated Spurious EIRP for 7527C							
H Polarization				V Polarization			
Frequency (MHz)	EIRP (dBm)	Limit (dBm)	Margin (dB)	Frequency (MHz)	EIRP (dBm)	Limit (dBm)	Margin (dB)
72.390	-55.350	-13	-42.35	33.240	-54.640	-13	-41.64
80.490	-58.460	-13	-45.46	71.580	-51.050	-13	-38.05
143.130	-56.640	-13	-43.64	143.130	-52.180	-13	-39.18
311.900	-61.000	-13	-48.00	336.400	-60.500	-13	-47.50
519.800	-61.770	-13	-48.77	519.800	-60.680	-13	-47.68
995.800	-63.670	-13	-50.67	990.900	-61.580	-13	-48.58
1718.000	-53.160	-13	-40.16	1454.000	-51.010	-13	-38.01
3758.000	-52.020	-13	-39.02	1718.000	-58.720	-13	-45.72
5638.000	-44.560	-13	-31.56	3758.000	-47.840	-13	-34.84
				5638.000	-43.220	-13	-30.22
				11278.000	-42.170	-13	-29.17



- Test Mode : Mode 23

PCS1900 (GSM) + POD 1 Radiated Spurious EIRP for 7527C							
H Polarization				V Polarization			
Frequency (MHz)	EIRP (dBm)	Limit (dBm)	Margin (dB)	Frequency (MHz)	EIRP (dBm)	Limit (dBm)	Margin (dB)
72.390	-58.610	-13	-45.61	72.930	-52.200	-13	-39.20
88.590	-61.590	-13	-48.59	100.740	-51.660	-13	-38.66
186.330	-62.070	-13	-49.07	149.340	-50.520	-13	-37.52
376.300	-62.780	-13	-49.78	467.300	-57.350	-13	-44.35
519.800	-64.770	-13	-51.77	519.800	-55.400	-13	-42.40
992.300	-63.590	-13	-50.59	876.800	-61.660	-13	-48.66
1718.000	-52.900	-13	-39.90	1718.000	-55.190	-13	-42.19
2038.000	-57.020	-13	-44.02	3758.000	-46.670	-13	-33.67
5638.000	-40.010	-13	-27.01	5638.000	-40.870	-13	-27.87
11278.000	-40.030	-13	-27.03	11278.000	-41.750	-13	-28.75

- Test Mode : Mode 24

PCS1900 (GSM) + POD 2 Radiated Spurious EIRP for 7527C							
H Polarization				V Polarization			
Frequency (MHz)	EIRP (dBm)	Limit (dBm)	Margin (dB)	Frequency (MHz)	EIRP (dBm)	Limit (dBm)	Margin (dB)
72.390	-58.020	-13	-45.02	34.590	-54.350	-13	-41.35
81.840	-61.480	-13	-48.48	72.390	-52.390	-13	-39.39
186.330	-61.440	-13	-48.44	149.340	-50.620	-13	-37.62
376.300	-63.600	-13	-50.60	397.300	-63.100	-13	-50.10
568.800	-63.500	-13	-50.50	469.400	-57.990	-13	-44.99
969.900	-63.600	-13	-50.60	518.400	-55.690	-13	-42.69
1718.000	-52.120	-13	-39.12	1718.000	-54.340	-13	-41.34
2038.000	-58.200	-13	-45.20	2044.000	-58.390	-13	-45.39
3758.000	-50.670	-13	-37.67	3758.000	-49.370	-13	-36.37
5638.000	-47.890	-13	-34.89	5638.000	-49.860	-13	-36.86
11278.000	-40.320	-13	-27.32	11278.000	-41.480	-13	-28.48



- Test Mode : Mode 25

PCS1900 (GSM) + POD 3 Radiated Spurious EIRP for 7527C							
H Polarization				V Polarization			
Frequency (MHz)	EIRP (dBm)	Limit (dBm)	Margin (dB)	Frequency (MHz)	EIRP (dBm)	Limit (dBm)	Margin (dB)
72.930	-58.310	-13	-45.31	71.580	-52.330	-13	-39.33
87.780	-61.860	-13	-48.86	147.990	-50.040	-13	-37.04
187.680	-60.460	-13	-47.46	155.280	-51.790	-13	-38.79
329.400	-63.690	-13	-50.69	465.900	-58.450	-13	-45.45
519.800	-65.040	-13	-52.04	481.300	-58.750	-13	-45.75
981.800	-64.200	-13	-51.20	519.800	-54.370	-13	-41.37
1718.000	-52.500	-13	-39.50	1718.000	-55.780	-13	-42.78
1748.000	-53.320	-13	-40.32	2338.000	-57.690	-13	-44.69
2038.000	-59.320	-13	-46.32	3758.000	-52.720	-13	-39.72
3758.000	-50.060	-13	-37.06	5638.000	-50.300	-13	-37.30
5638.000	-52.170	-13	-39.17	11278.000	-39.920	-13	-26.92

- Test Mode : Mode 26

PCS1900 (GSM) + POD 4 Radiated Spurious EIRP for 7527C							
H Polarization				V Polarization			
Frequency (MHz)	EIRP (dBm)	Limit (dBm)	Margin (dB)	Frequency (MHz)	EIRP (dBm)	Limit (dBm)	Margin (dB)
72.930	-58.020	-13	-45.02	33.240	-53.200	-13	-40.20
88.590	-61.600	-13	-48.60	149.340	-48.810	-13	-35.81
187.140	-60.320	-13	-47.32	156.630	-51.320	-13	-38.32
329.400	-64.380	-13	-51.38	472.900	-58.780	-13	-45.78
350.400	-64.180	-13	-51.18	488.300	-58.580	-13	-45.58
519.800	-65.160	-13	-52.16	519.800	-55.890	-13	-42.89
1718.000	-53.030	-13	-40.03	1258.000	-42.250	-13	-29.25
2038.000	-58.420	-13	-45.42	1718.000	-54.940	-13	-41.94
3758.000	-49.340	-13	-36.34	3758.000	-52.160	-13	-39.16
5638.000	-49.220	-13	-36.22	5638.000	-50.740	-13	-37.74
11278.000	-41.090	-13	-28.09	11278.000	-40.270	-13	-27.27



- Test Mode : Mode 27

PCS1900 (GSM) + POD 6 Radiated Spurious EIRP for 7527C							
H Polarization				V Polarization			
Frequency (MHz)	EIRP (dBm)	Limit (dBm)	Margin (dB)	Frequency (MHz)	EIRP (dBm)	Limit (dBm)	Margin (dB)
33.780	-52.550	-13	-39.55	33.240	-45.530	-13	-32.53
71.580	-54.420	-13	-41.42	72.390	-49.310	-13	-36.31
191.190	-57.660	-13	-44.66	149.340	-45.030	-13	-32.03
383.300	-61.110	-13	-48.11	519.800	-54.540	-13	-41.54
743.800	-60.170	-13	-47.17	913.900	-55.250	-13	-42.25
792.800	-59.760	-13	-46.76	960.800	-55.830	-13	-42.83
1718.000	-51.200	-13	-38.20	1394.000	-50.290	-13	-37.29
2038.000	-58.050	-13	-45.05	1718.000	-55.200	-13	-42.20
3758.000	-47.860	-13	-34.86	3758.000	-50.480	-13	-37.48
5638.000	-44.390	-13	-31.39	5638.000	-47.790	-13	-34.79
11278.000	-39.670	-13	-26.67	11278.000	-42.810	-13	-29.81

- Test Mode : Mode 28

PCS1900 (EDGE) + Endcap 2 Radiated Spurious EIRP for 7527C							
H Polarization				V Polarization			
Frequency (MHz)	EIRP (dBm)	Limit (dBm)	Margin (dB)	Frequency (MHz)	EIRP (dBm)	Limit (dBm)	Margin (dB)
71.580	-61.620	-13	-48.62	60.240	-54.550	-13	-41.55
138.540	-58.840	-13	-45.84	146.640	-50.840	-13	-37.84
144.480	-56.260	-13	-43.26	153.930	-51.280	-13	-38.28
397.300	-60.980	-13	-47.98	344.800	-60.760	-13	-47.76
418.300	-62.060	-13	-49.06	376.300	-59.300	-13	-46.30
519.800	-62.130	-13	-49.13	428.800	-60.640	-13	-47.64
1718.000	-55.660	-13	-42.66	1718.000	-57.760	-13	-44.76



- Test Mode : Mode 29

PCS1900 (GSM) + Endcap 2 + Pistol Grips Radiated Spurious EIRP for 7527C							
H Polarization				V Polarization			
Frequency (MHz)	EIRP (dBm)	Limit (dBm)	Margin (dB)	Frequency (MHz)	EIRP (dBm)	Limit (dBm)	Margin (dB)
73.740	-56.920	-13	-43.92	141.780	-48.080	-13	-35.08
141.780	-54.880	-13	-41.88	149.880	-48.500	-13	-35.50
149.880	-55.840	-13	-42.84	158.790	-48.960	-13	-35.96
453.300	-62.910	-13	-49.91	351.800	-54.210	-13	-41.21
523.300	-60.920	-13	-47.92	525.400	-62.630	-13	-49.63
810.300	-62.390	-13	-49.39	925.800	-59.810	-13	-46.81
1718.000	-54.010	-13	-41.01	1498.000	-57.070	-13	-44.07
3758.000	-49.230	-13	-36.23	1718.000	-56.590	-13	-43.59
5638.000	-46.490	-13	-33.49	3758.000	-50.070	-13	-37.07
				5638.000	-42.880	-13	-29.88

- Test Mode : Mode 30

GSM850 (GSM) + Endcap 5 Radiated Spurious ERP for 7527S							
H Polarization				V Polarization			
Frequency (MHz)	ERP (dBm)	Limit (dBm)	Margin (dB)	Frequency (MHz)	ERP (dBm)	Limit (dBm)	Margin (dB)
32.430	-48.920	-13	-35.92	33.240	-37.110	-13	-24.11
143.130	-52.240	-13	-39.24	151.230	-47.520	-13	-34.52
221.430	-38.710	-13	-25.71	220.890	-37.900	-13	-24.90
995.800	-52.870	-13	-39.87	995.800	-61.360	-13	-48.36
1674.000	-16.300	-13	-3.30	1674.000	-21.250	-13	-8.25
2508.000	-30.990	-13	-17.99	2508.000	-31.480	-13	-18.48
3344.000	-44.430	-13	-31.43	3344.000	-45.600	-13	-32.60
4178.000	-52.210	-13	-39.21	4184.000	-51.650	-13	-38.65
5018.000	-45.730	-13	-32.73	5018.000	-45.140	-13	-32.14
5854.000	-53.400	-13	-40.40	5854.000	-52.070	-13	-39.07



- Test Mode : Mode 31

PCS1900 (GSM) + Endcap 2 Radiated Spurious EIRP for 7527S							
H Polarization				V Polarization			
Frequency (MHz)	EIRP (dBm)	Limit (dBm)	Margin (dB)	Frequency (MHz)	EIRP (dBm)	Limit (dBm)	Margin (dB)
71.580	-63.730	-13	-50.73	33.510	-54.590	-13	-41.59
145.290	-56.260	-13	-43.26	60.780	-56.740	-13	-43.74
157.170	-61.770	-13	-48.77	145.290	-52.020	-13	-39.02
348.300	-57.150	-13	-44.15	778.800	-62.130	-13	-49.13
386.800	-64.110	-13	-51.11	852.300	-62.100	-13	-49.10
957.300	-62.360	-13	-49.36	950.300	-61.050	-13	-48.05
1718.000	-51.690	-13	-38.69	1718.000	-55.840	-13	-42.84
2038.000	-56.580	-13	-43.58	2038.000	-57.230	-13	-44.23
3758.000	-49.660	-13	-36.66	3758.000	-48.100	-13	-35.10



4.6.5 Test Data

4.6.5.1 Mode 1

Horizontal Polarization

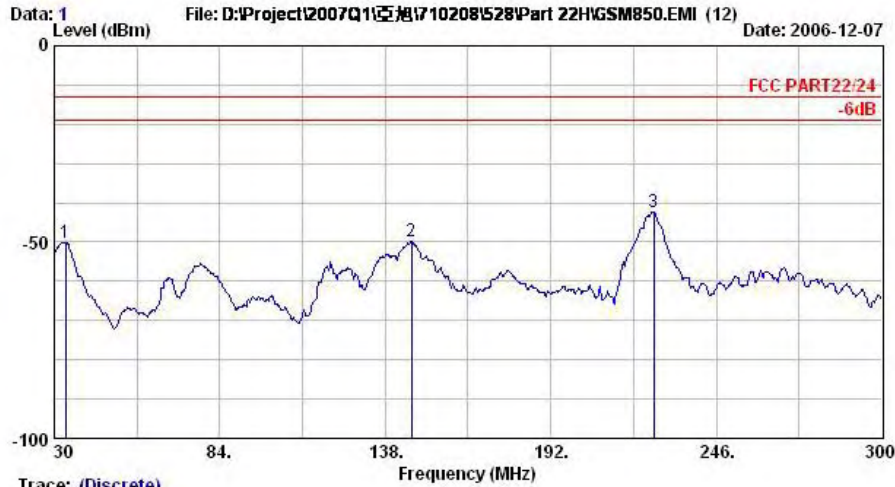

Trace: (Discrete)
 Site : 08CH06-HY
 Condition : LF-SPURIOUS HORIZONTAL
 EUT : FDA
 Power : 120Wac/60Hz
 Model : FG 710211
 Memo : GSM850 Link Mode;Ch189+ Adaptor
 Plane : E2

	Freq MHz	Level dBm	Over Limit dB	Limit Line dBm	Read Level dBm	Factor dB	Remark
1 @	33.8	-50.11	-37.11	-13.00	-48.04	-2.08	Peak
2 @	146.6	-49.68	-36.68	-13.00	-36.90	-12.78	Peak
3 @	225.5	-42.50	-29.50	-13.00	-30.01	-12.49	Peak

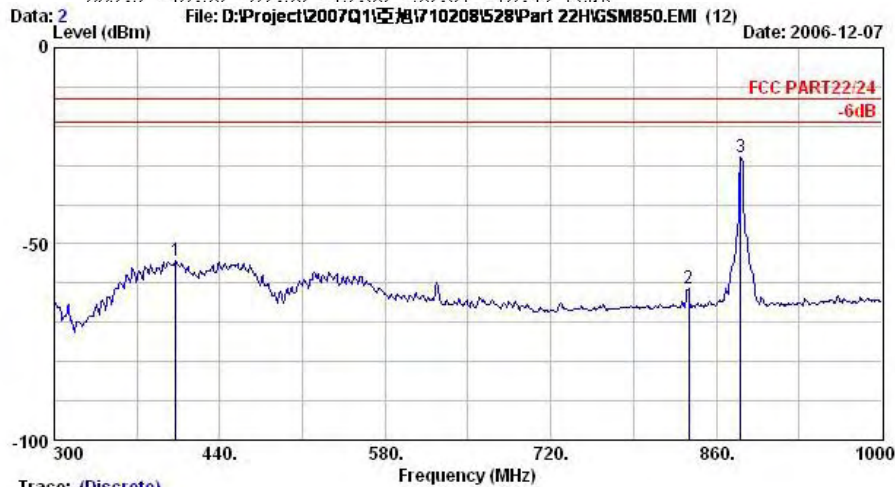

Trace: (Discrete)
 Site : 08CH06-HY
 Condition : LF-SPURIOUS HORIZONTAL
 EUT : FDA
 Power : 120Wac/60Hz
 Model : FG 710211
 Memo : GSM850 Link Mode;Ch189+ Adaptor
 Plane : E2

	Freq MHz	Level dBm	Over Limit dB	Limit Line dBm	Read Level dBm	Factor dB	Remark
1 @	402.9	-54.41	-41.41	-13.00	-47.95	-6.46	Peak
2 @	836.9	-61.42			-60.08	-1.33	Peak
3 @	880.3	-27.95			-27.03	-0.91	Peak

Remark:

1. #2: MS Signal
2. #3: BS Signal



Data: 3 File: D:\Project\2007Q1\200710208528\Part 22HGSM850.EMI (12) Date: 2006-12-07

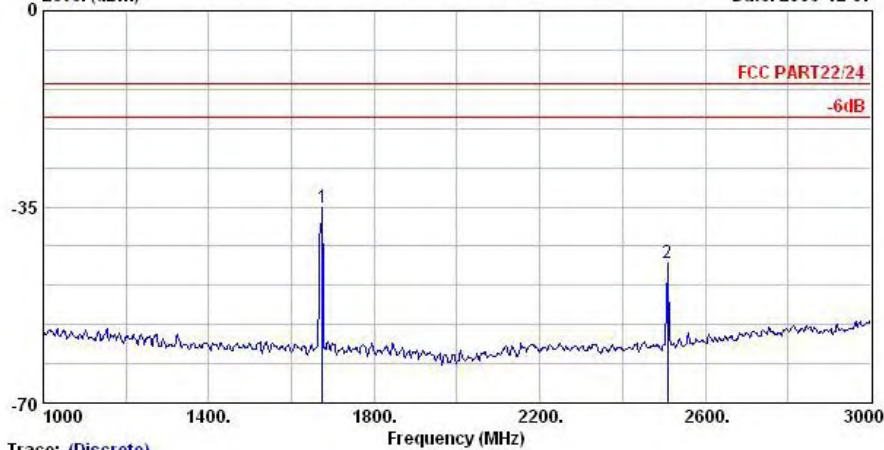

Trace: (Discrete)
 Site : 08CH06-HY
 Condition : HF-SPURIOUS HORIZONTAL
 EUT : PDA
 Power : 120Vac/60Hz
 Model : FG 710211
 Memo : GSM850 Link Mode;Ch189+ Adaptor
 Plane : E2

	Freq MHz	Level dBm	Over Limit dB	Limit Line dBm	Read Level dBm	Factor dB	Remark
1 @	1674.0	-35.06	-22.06	-13.00	-35.28	0.22	Peak
2 @	2508.0	-45.08	-32.08	-13.00	-46.28	1.20	Peak

Data: 4 File: D:\Project\2007Q1\200710208528\Part 22HGSM850.EMI (12) Date: 2006-12-07

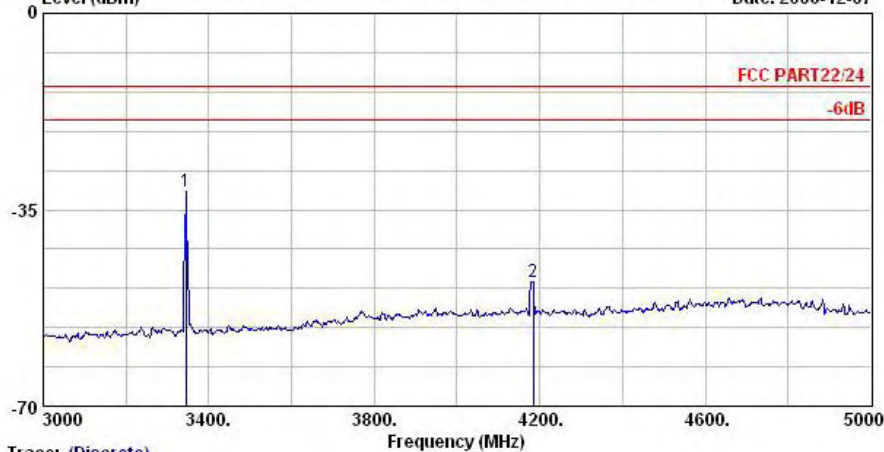

Trace: (Discrete)
 Site : 08CH06-HY
 Condition : HF-SPURIOUS HORIZONTAL
 EUT : PDA
 Power : 120Vac/60Hz
 Model : FG 710211
 Memo : GSM850 Link Mode;Ch189+ Adaptor
 Plane : E2

	Freq MHz	Level dBm	Over Limit dB	Limit Line dBm	Read Level dBm	Factor dB	Remark
1 @	3344.0	-31.64	-18.64	-13.00	-37.04	5.41	Peak
2 @	4184.0	-47.88	-34.88	-13.00	-57.67	9.79	Peak



Data: 5 File: D:\Project\2007Q1\5710208\528\Part 22\HGSM850.EMI (12) Date: 2006-12-07

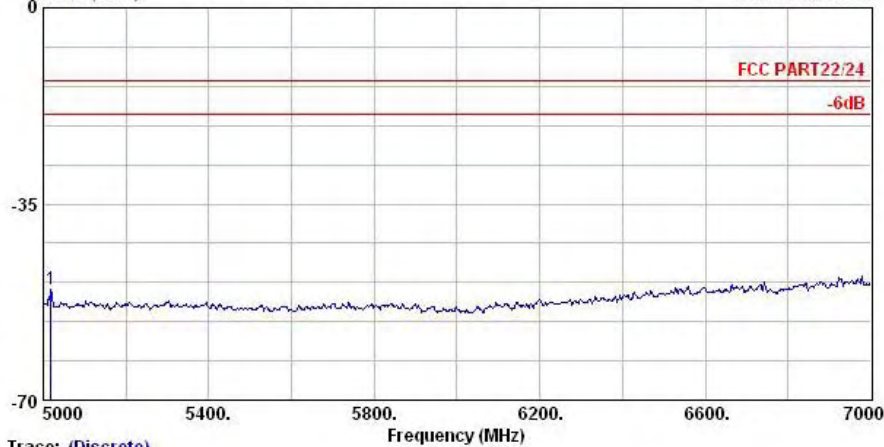

Trace: (Discrete)

Site : 08CH06-HY

Condition : HF-SPURIOUS HORIZONTAL

EUT : PDA

Power : 120Vac,60Hz

Model : FG 710211

Memo : GSM850 Link Mode;Ch189+ Adaptor

Plane : E2

	Freq	Level	Over	Limit	Read	Factor	Remark
	MHz	dBm	dB	dBm	dBm	dB	
1 @	5018.0	-50.10	-37.10	-13.00	-60.33	10.24	Peak

Data: 6 File: D:\Project\2007Q1\5710208\528\Part 22\HGSM850.EMI (12) Date: 2006-12-07

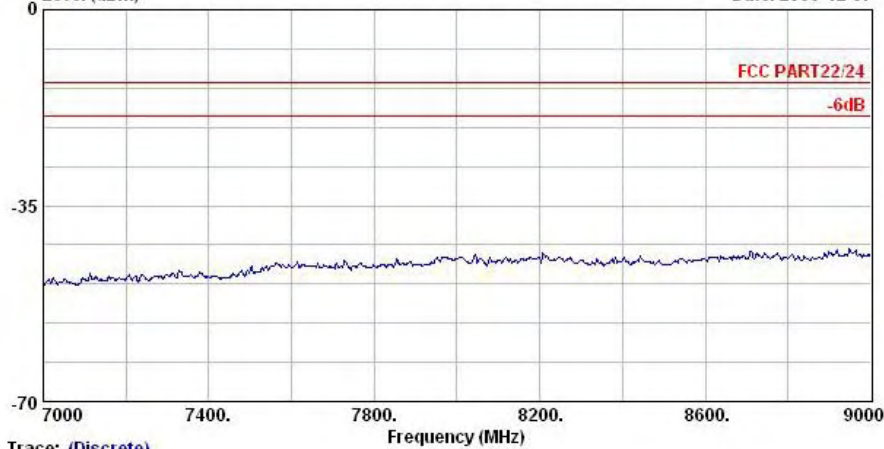

Trace: (Discrete)

Site : 08CH06-HY

Condition : HF-SPURIOUS HORIZONTAL

EUT : PDA

Power : 120Vac,60Hz

Model : FG 710211

Memo : GSM850 Link Mode;Ch189+ Adaptor

Plane : E2



Vertical Polarization

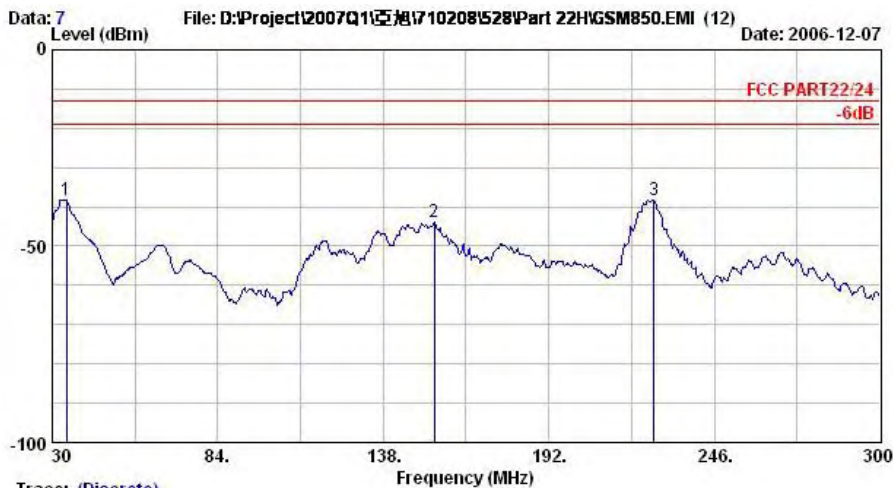

Trace: (Discrete)
 Site : 08CH06-HY
 Condition : LF-SPURIOUS VERTICAL
 EUT : FDA
 Power : 120Wac/60Hz
 Model : FG 710211
 Memo : GSM850 Link Mode;Ch189+ Adaptor
 Plane : E2

	Freq	Level	Over	Limit	Read	
	MHz	dBm	Limit	Line	Level	Factor Remark
			dB	dBm	dBm	dB
1 @	34.6	-38.21	-25.21	-13.00	-27.77	-10.44 Peak
2 @	154.7	-43.86	-30.86	-13.00	-35.68	-8.19 Peak
3 @	226.3	-38.23	-25.23	-13.00	-30.19	-8.03 Peak

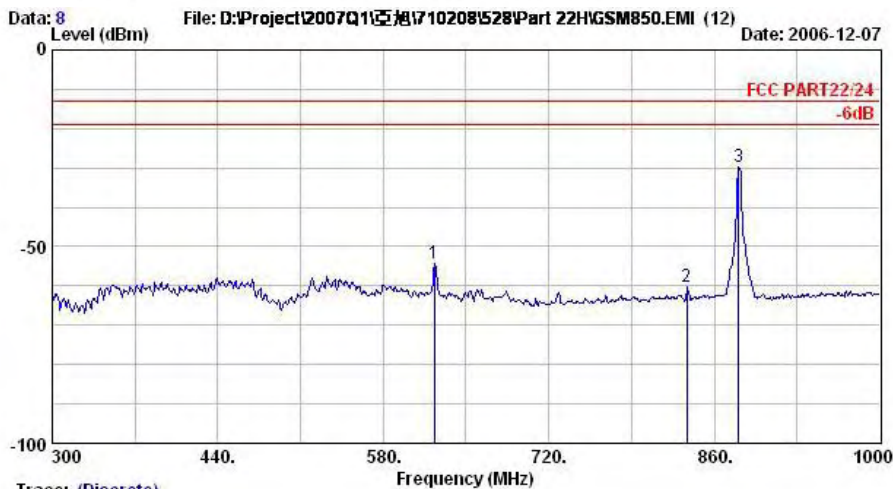

Trace: (Discrete)
 Site : 08CH06-HY
 Condition : LF-SPURIOUS VERTICAL
 EUT : FDA
 Power : 120Wac/60Hz
 Model : FG 710211
 Memo : GSM850 Link Mode;Ch189+ Adaptor
 Plane : E2

	Freq	Level	Over	Limit	Read	
	MHz	dBm	Limit	Line	Level	Factor Remark
			dB	dBm	dBm	dB
1 @	623.4	-54.27	-41.27	-13.00	-52.69	-1.58 Peak
2 @	836.9	-60.32			-61.68	1.36 Peak
3 @	880.3	-29.83			-31.54	1.71 Peak

Remark:

- 1. #2: MS Signal
- 2. #3: BS Signal



Data: 9 File: D:\Project\2007Q1\528\1710208\528\Part 22HGSM850.EMI (12) Date: 2006-12-07

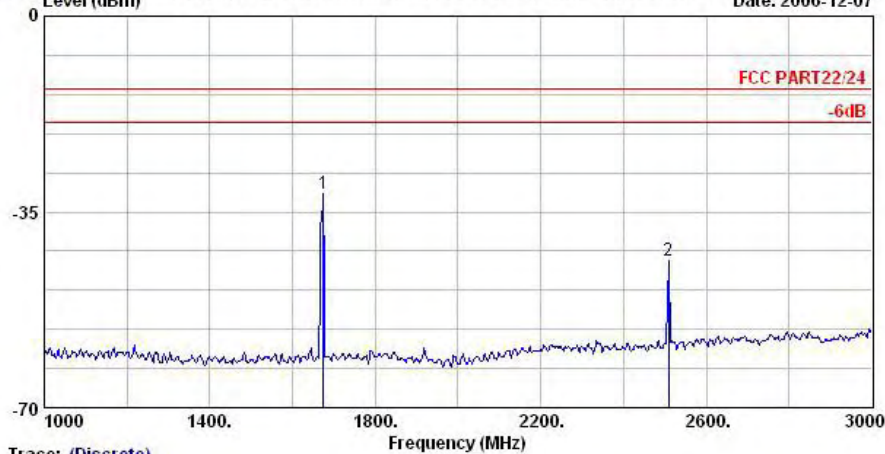

Trace: (Discrete)
 Site : 08CH06-HY
 Condition : HF-SPURIOUS VERTICAL
 EUT : PDA
 Power : 120Vac,60Hz
 Model : FG 710211
 Memo : GSM850 Link Mode;Ch189+Adaptor
 Plane : E2

	Freq	Level	Over	Limit	Read	Factor	Remark
	MHz	dBm	dB	dBm	dBm	dB	
1 @	1674.0	-31.87	-18.87	-13.00	-31.39	-0.48	Peak
2 @	2508.0	-43.67	-30.67	-13.00	-45.94	2.27	Peak

Data: 10 File: D:\Project\2007Q1\528\1710208\528\Part 22HGSM850.EMI (12) Date: 2006-12-07

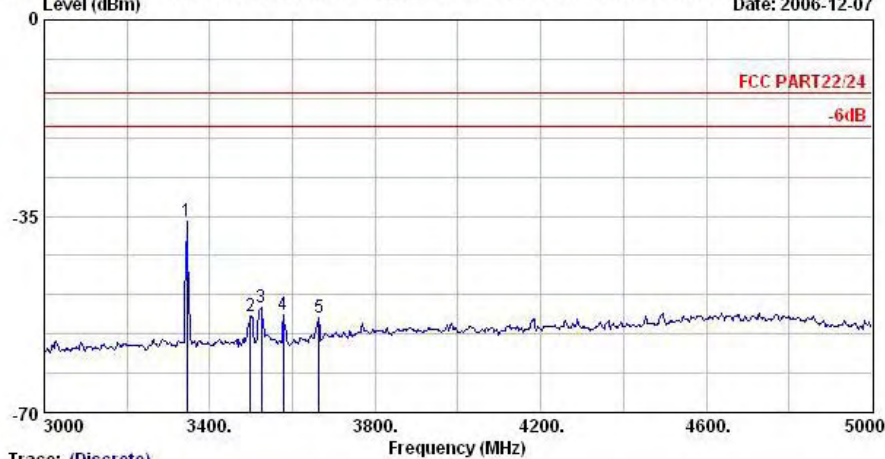

Trace: (Discrete)
 Site : 08CH06-HY
 Condition : HF-SPURIOUS VERTICAL
 EUT : PDA
 Power : 120Vac,60Hz
 Model : FG 710211
 Memo : GSM850 Link Mode;Ch189+Adaptor
 Plane : E2

	Freq	Level	Over	Limit	Read	Factor	Remark
	MHz	dBm	dB	dBm	dBm	dB	
1 @	3344.0	-35.87	-22.87	-13.00	-40.33	4.47	Peak
2 @	3498.0	-52.79	-39.79	-13.00	-57.66	4.87	Peak
3 @	3524.0	-51.22	-38.22	-13.00	-56.15	4.93	Peak
4 @	3578.0	-52.53	-39.53	-13.00	-57.81	5.28	Peak
5 @	3664.0	-53.21	-40.21	-13.00	-58.98	5.77	Peak



Data: 11 File: D:\Project\2007Q1\581710208\528\Part 22HGSM850.EMI (12) Date: 2006-12-07

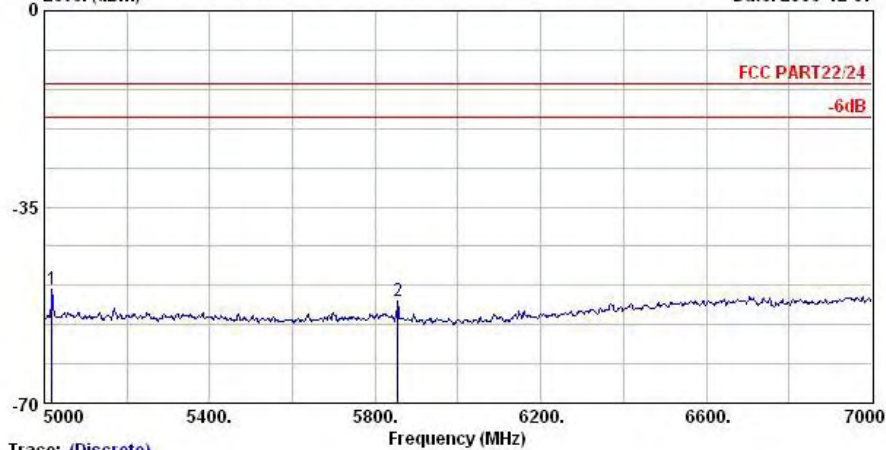

Trace: (Discrete)

Site : 08CHO6-HY
 Condition : HF-SPURIOUS VERTICAL
 EUT : PDA
 Power : 120Vac,60Hz
 Model : FG 710211
 Memo : GSM850 Link Mode;Ch189+ Adaptor
 Plane : E2

	Freq	Level	Over	Limit	Read	Factor	Remark
	MHz	dBm	dB	dBm	dBm	dB	
1 @	5018.0	-49.64	-36.64	-13.00	-58.49	8.85	Peak
2 @	5854.0	-51.66	-38.66	-13.00	-60.47	8.81	Peak

Data: 12 File: D:\Project\2007Q1\581710208\528\Part 22HGSM850.EMI (12) Date: 2006-12-07

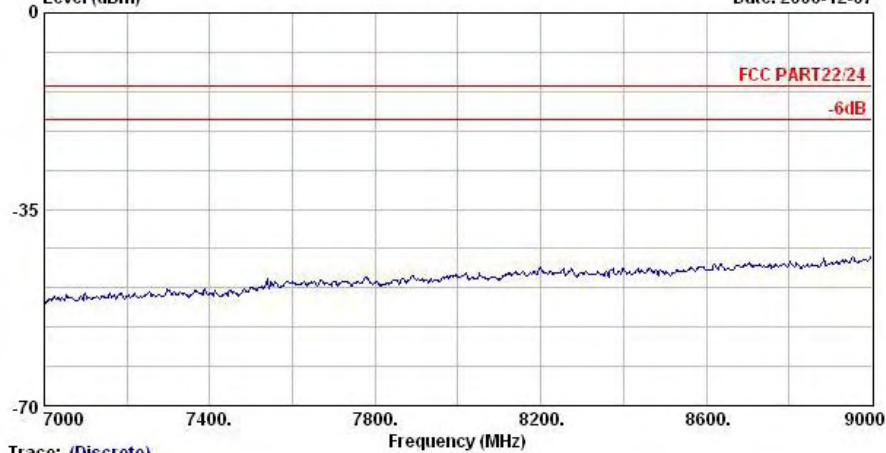

Trace: (Discrete)

Site : 08CHO6-HY
 Condition : HF-SPURIOUS VERTICAL
 EUT : PDA
 Power : 120Vac,60Hz
 Model : FG 710211
 Memo : GSM850 Link Mode;Ch189+ Adaptor
 Plane : E2

Remark : There is no more obvious emission except the listings above.



4.6.5.2 Mode 2
Horizontal Polarization

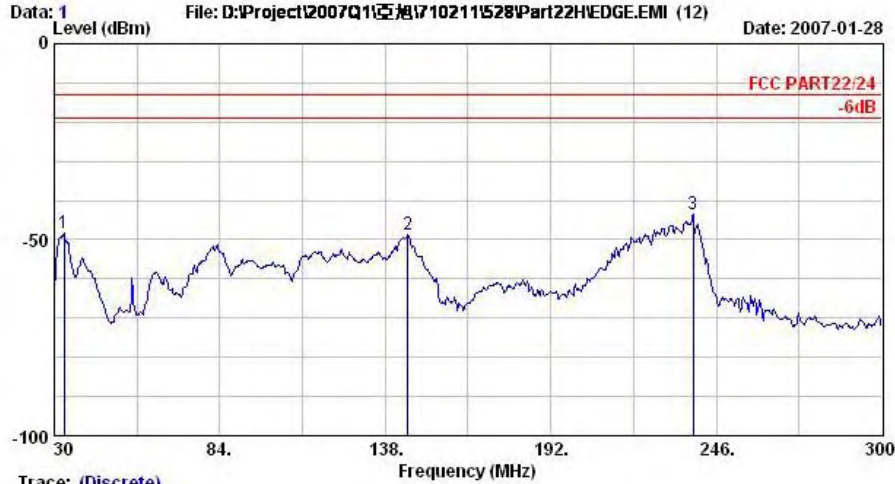

Trace: (Discrete)
 Site : 08CH06-HY
 Condition : LF-SPURIOUS HORIZONTAL
 EUT : PDA with GPRS/EDGE+WLAN11g+BT
 Power : 120Vac/60Hz
 Model : FG710211
 Memo : EDGE Link Mode;Ch189+Adaptor
 Plane : E2

	Freq MHz	Level dBm	Over Limit dB	Limit Line dBm	Read Level dBm	Factor dB	Remark
1	33.2	-48.33	-35.33	-13.00	-46.87	-1.47	Peak
2	145.3	-48.75	-35.75	-13.00	-35.98	-12.76	Peak
3 @	238.4	-43.41	-30.41	-13.00	-31.35	-12.05	Peak

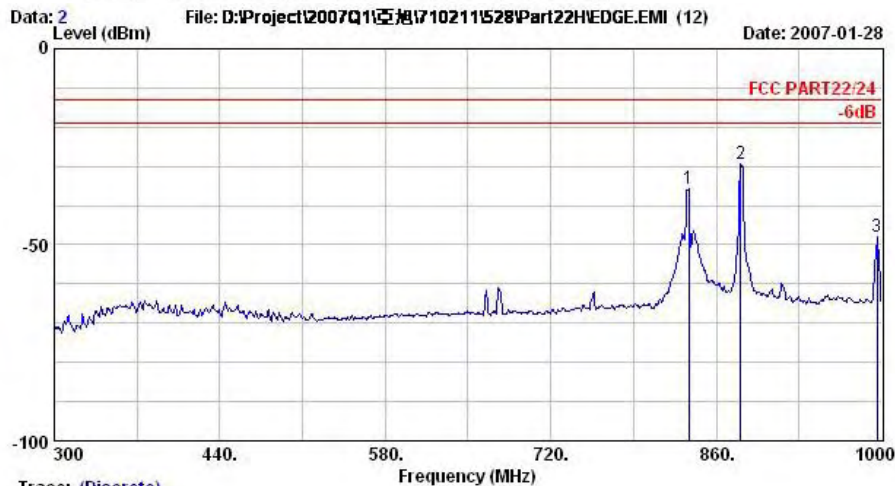

Trace: (Discrete)
 Site : 08CH06-HY
 Condition : LF-SPURIOUS HORIZONTAL
 EUT : PDA with GPRS/EDGE+WLAN11g+BT
 Power : 120Vac/60Hz
 Model : FG710211
 Memo : EDGE Link Mode;Ch189+Adaptor
 Plane : E2

	Freq MHz	Level dBm	Over Limit dB	Limit Line dBm	Read Level dBm	Factor dB	Remark
1 @	836.9	-35.81			-34.48	-1.33	Peak
2 @	880.3	-29.33			-28.42	-0.91	Peak
3	995.8	-47.99	-34.99	-13.00	-48.20	0.20	Peak

Remark:
 1. #1: MS Signal
 2. #2: BS Signal



Data: 3 File: D:\Project\2007Q1\581710211\528\Part22\HEDGE.EMI (12) Date: 2007-01-28

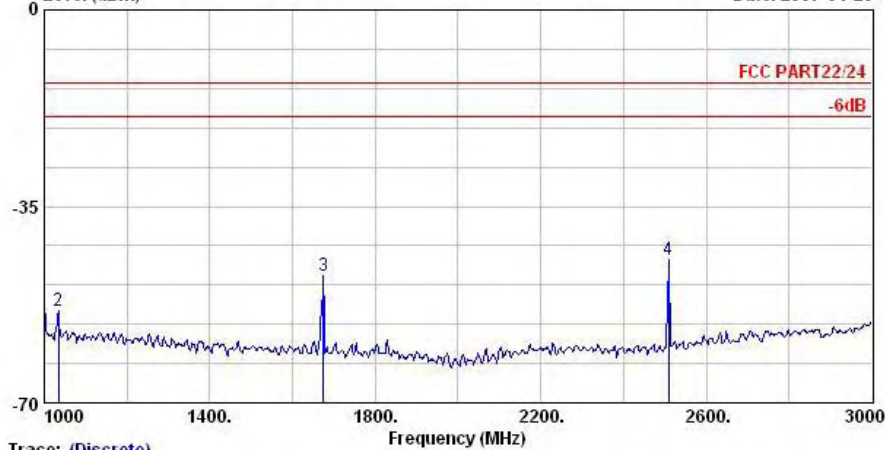

Trace: (Discrete)

Site : 08CH06-HY
 Condition : HF-SFURIOUS HORIZONTAL
 EUT : PDA with GPRS/EDGE+WLAN11g+BT
 Power : 120Vac/60Hz
 Model : FG710211
 Memo : EDGE Link Mode;Ch189+Adaptcx
 Plane : E2

	Freq	Level	Over	Limit	Read		
	MHz	dBm	dB	dBm	dBm	dB	Remark
1	1000.0	-52.73	-39.73	-13.00	-54.54	1.80	Peak
2	1034.0	-53.53	-40.53	-13.00	-55.30	1.78	Peak
3	1674.0	-47.24	-34.24	-13.00	-47.46	0.22	Peak
4	2508.0	-44.53	-31.53	-13.00	-45.73	1.20	Peak

Data: 4 File: D:\Project\2007Q1\581710211\528\Part22\HEDGE.EMI (12) Date: 2007-01-28

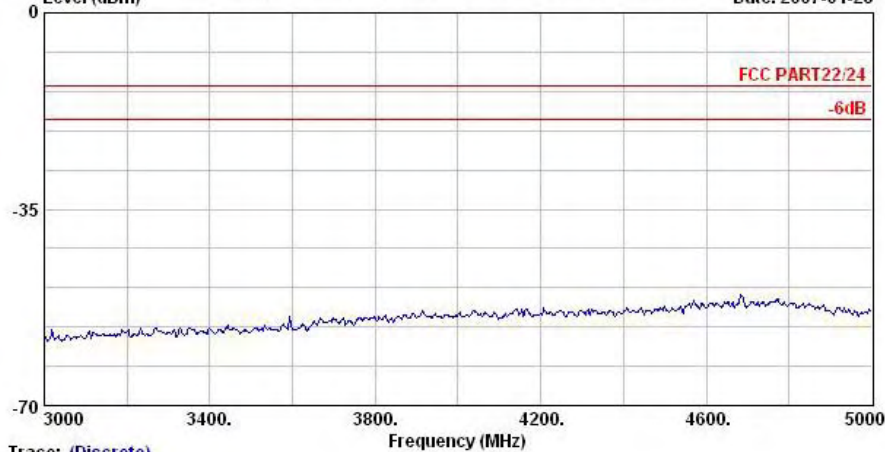

Trace: (Discrete)

Site : 08CH06-HY
 Condition : HF-SFURIOUS HORIZONTAL
 EUT : PDA with GPRS/EDGE+WLAN11g+BT
 Power : 120Vac/60Hz
 Model : FG710211
 Memo : EDGE Link Mode;Ch189+Adaptcx
 Plane : E2

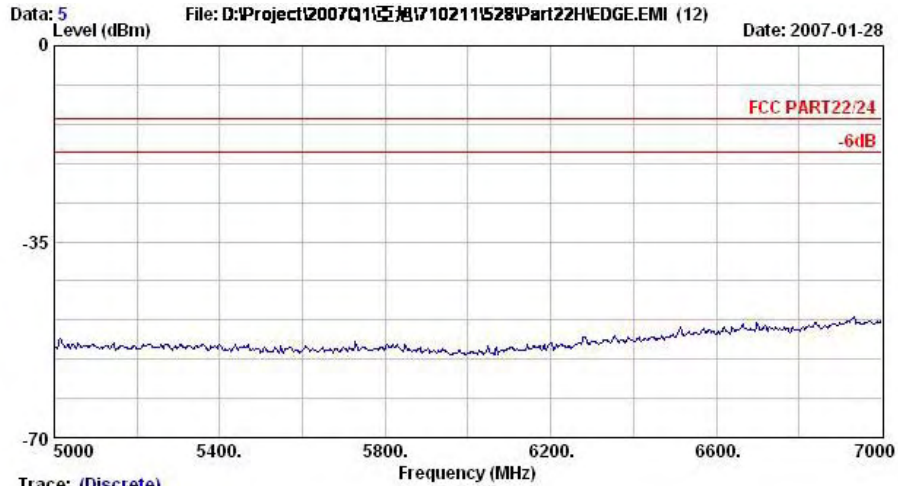

Trace: (Discrete)

Site : 03CH06-HY
Condition : HF-SPURIOUS HORIZONTAL
EUT : PDA with GPRS/EDGE+WLAN11g+BT
Power : 120Vac/60Hz
Model : FG710211
Memo : EDGE Link Mode;Ch189+Adaptor
Plane : E2



Vertical Polarization

Data: 7 File: D:\Project\2007Q1\亞旭\710211\528\Part22\HEDGE.EMI (12) Date: 2007-01-28

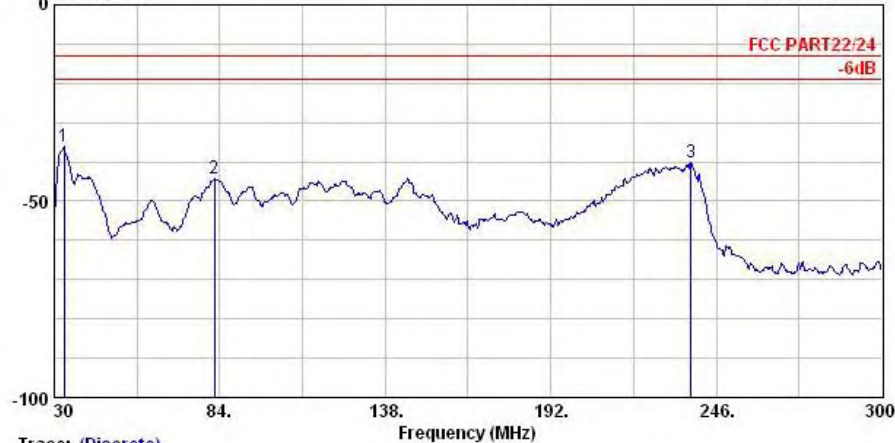

Trace: (Discrete)

Site : 08CHO6-HY

Condition : LF-SPURIOUS VERTICAL

EUT : PDA with GPRS/EDGE+WLAN11g+BT

Power : 120Vac/60Hz

Model : FG710211

Memo : EDGE Link Mode;Ch189+ Adaptor

Plane : E2

	Freq	Level	Over	Limit	Read		
	MHz	dBm	Limit	Line	Level	Factor	Remark
			dB	dBm	dBm	dB	
1 @	33.2	-35.97	-22.97	-13.00	-26.07	-9.89	Peak
2	82.4	-44.35	-31.35	-13.00	-34.15	-10.21	Peak
3 @	237.6	-40.01	-27.01	-13.00	-32.23	-7.78	Peak

Data: 8 File: D:\Project\2007Q1\亞旭\710211\528\Part22\HEDGE.EMI (12) Date: 2007-01-28

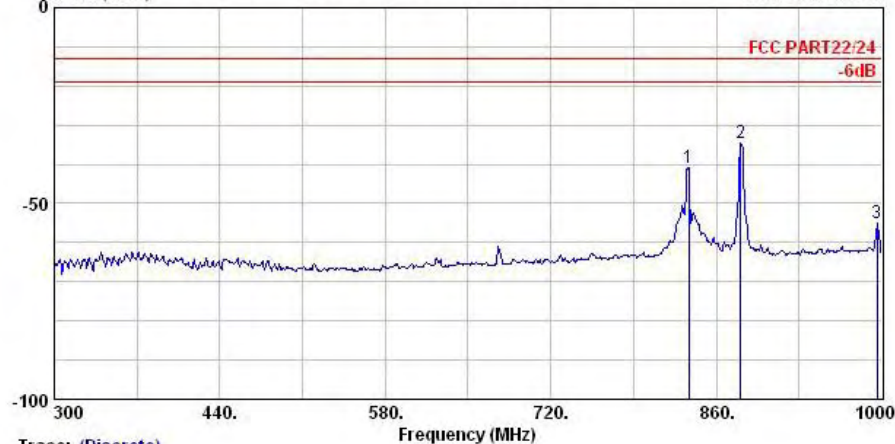

Trace: (Discrete)

Site : 08CHO6-HY

Condition : LF-SPURIOUS VERTICAL

EUT : PDA with GPRS/EDGE+WLAN11g+BT

Power : 120Vac/60Hz

Model : FG710211

Memo : EDGE Link Mode;Ch189+ Adaptor

Plane : E2

	Freq	Level	Over	Limit	Read		
	MHz	dBm	Limit	Line	Level	Factor	Remark
			dB	dBm	dBm	dB	
1 @	836.9	-40.89			-42.25	1.36	Peak
2 @	880.3	-34.56			-36.28	1.71	Peak
3	995.8	-54.92	-41.92	-13.00	-57.55	2.63	Peak

Remark:

- #1: MS Signal
- #2: BS Signal