

# ENGINEERING TEST REPORT



## WORKABOUT PRO (Handheld Computer) Model No.: 7525-RA2025

**FCC ID: GM37525RA2025**

*Applicant:*

**Psion Teklogix Inc.**  
2100 Meadowvale Blvd.  
Mississauga, ON  
Canada, L5N 7J9

*In Accordance With*

**Federal Communications Commission (FCC)  
Part 15, Subpart C, Section 15.247  
Digital Modulation Transmitters Operating in the  
Frequency Band 2400 - 2483.5 MHz**

**UltraTech's File No.: TEK-461F15C247**

This Test report is Issued under the Authority of  
Tri M. Luu, Professional Engineer,  
Vice President of Engineering  
UltraTech Group of Labs



Date: September 2, 2004

Report Prepared by: Dan Huynh

Tested by: Hung Trinh, EMC Technician

Issued Date: September 2, 2004

Test Dates: August 7, 2004

- *The results in this Test Report apply only to the sample(s) tested, and the sample tested is randomly selected.*
- *This report must not be used by the client to claim product endorsement by NVLAP or any agency of the US Government.*

## UltraTech

3000 Bristol Circle, Oakville, Ontario, Canada, L6H 6G4  
Tel.: (905) 829-1570 Fax.: (905) 829-8050

Website: [www.ultratech-labs.com](http://www.ultratech-labs.com), Email: [vic@ultratech-labs.com](mailto:vic@ultratech-labs.com), Email: [tri.luu@sympatico.ca](mailto:tri.luu@sympatico.ca)



31040/SIT



C-1376



46390-2049



200093-0



SL2-IN-E-1119R



00-034



## TABLE OF CONTENTS

<b>EXHIBIT 1.</b>	<b>SUBMITTAL CHECK LIST .....</b>	<b>1</b>
<b>EXHIBIT 2.</b>	<b>INTRODUCTION.....</b>	<b>2</b>
2.1.	SCOPE .....	2
2.2.	RELATED SUBMITTAL(S)/GRANT(S).....	2
2.3.	NORMATIVE REFERENCES .....	2
<b>EXHIBIT 3.</b>	<b>PERFORMANCE ASSESSMENT .....</b>	<b>3</b>
3.1.	CLIENT INFORMATION.....	3
3.2.	EQUIPMENT UNDER TEST (EUT) INFORMATION.....	3
3.3.	EUT'S TECHNICAL SPECIFICATIONS.....	4
3.4.	LIST OF EUT'S PORTS.....	4
<b>EXHIBIT 4.</b>	<b>EUT OPERATING CONDITIONS AND CONFIGURATIONS DURING TESTS.....</b>	<b>5</b>
4.1.	CLIMATE TEST CONDITIONS .....	5
4.2.	OPERATIONAL TEST CONDITIONS & ARRANGEMENT FOR TESTS.....	5
4.3.	DRAWING OF TEST SETUP.....	6
<b>EXHIBIT 5.</b>	<b>SUMMARY OF TEST RESULTS.....</b>	<b>7</b>
5.1.	LOCATION OF TESTS.....	7
5.2.	APPLICABILITY & SUMMARY OF EMC EMISSION TEST RESULTS.....	7
5.3.	MODIFICATIONS INCORPORATED IN THE EUT FOR COMPLIANCE PURPOSES.....	7
<b>EXHIBIT 6.</b>	<b>MEASUREMENTS, EXAMINATIONS &amp; TEST DATA FOR EMC EMISSIONS.....</b>	<b>8</b>
6.1.	TEST PROCEDURES .....	8
6.2.	MEASUREMENT UNCERTAINTIES .....	8
6.3.	MEASUREMENT EQUIPMENT USED .....	8
6.4.	ESSENTIAL/PRIMARY FUNCTIONS AS DECLARED BY THE MANUFACTURER.....	8
6.5.	PEAK OUTPUT POWER (CONDUCTED) [§ 15.247(b)].....	9
6.6.	SPURIOUS EMISSIONS (RADIATED @ 3 METERS) [§§ 15.247(c), 15.209 & 15.205].....	10
<b>EXHIBIT 7.</b>	<b>MEASUREMENT UNCERTAINTY.....</b>	<b>18</b>
7.1.	LINE CONDUCTED EMISSION MEASUREMENT UNCERTAINTY.....	18
7.2.	RADIATED EMISSION MEASUREMENT UNCERTAINTY.....	19
<b>EXHIBIT 8.</b>	<b>MEASUREMENT METHODS.....</b>	<b>20</b>
8.1.	GENERAL TEST CONDITIONS.....	20
8.2.	PEAK CONDUCTED POWER & PEAK EIRP .....	21
8.3.	SPURIOUS EMISSIONS (CONDUCTED & RADIATED).....	24
8.4.	ALTERNATIVE TEST PROCEDURES .....	27

## EXHIBIT 1. SUBMITTAL CHECK LIST

Annex No.	Exhibit Type	Description of Contents	Quality Check (OK)
--	Test Report	Test Report	OK
1	Test Setup Photos	Radiated Emissions Setup Photos	OK
2	External Photos of EUT	External EUT Photos	OK
3	Internal Photos of EUT	Internal EUT Photos	OK
4	Cover Letters	Letter from Ultratech for Certification Request	OK
5	Attestation Statements	<ul style="list-style-type: none"><li>Letter from the Applicant to appoint Ultratech to act as an agent</li><li>Letter from the Applicant to request for Confidentiality Filing</li></ul>	OK OK
6	ID Label/Location Info	<ul style="list-style-type: none"><li>ID Label</li><li>Location of ID Label</li></ul>	OK
7	Block Diagrams	Block Diagram	OK
8	Schematic Diagrams	Schematic Diagrams	OK
9	Parts List/Tune Up Info	Parts List/Tune Up Info	OK
10	Operational Description	Operational Description	OK
11	RF Exposure Info	See SAR Test Report for Details	OK
12	Users Manual	Users Manual	OK

---

---

### ULTRATECH GROUP OF LABS

3000 Bristol Circle, Oakville, Ontario, Canada L6H 6G4  
Tel. #: 905-829-1570, Fax. #: 905-829-8050, Email: [vic@ultratech-labs.com](mailto:vic@ultratech-labs.com), Website: <http://www.ultratech-labs.com>

File #: TEK-461F15C247  
September 2, 2004

*All test results contained in this engineering test report are traceable to National Institute of Standards and Technology (NIST)*

## EXHIBIT 2. INTRODUCTION

### 2.1. SCOPE

<b>Reference:</b>	FCC Part 15, Subpart C, Section 15.247
<b>Title:</b>	Telecommunication - Code of Federal Regulations, CFR 47, Part 15
<b>Purpose of Test:</b>	To gain FCC Certification Authorization for Digital Modulation Transmitters operating in the Frequency Band 2400 - 2483.5 MHz .
<b>Test Procedures:</b>	Both conducted and radiated emissions measurements were conducted in accordance with American National Standards Institute ANSI C63.4 - American National Standard for Methods of Measurement of Radio-Noise Emissions from Low-Voltage Electrical and Electronic Equipment in the Range of 9 kHz to 40 GHz.
<b>Environmental Classification:</b>	<ul style="list-style-type: none"><li>• Light-industry, Commercial</li><li>• Industry</li></ul>

### 2.2. RELATED SUBMITTAL(S)/GRANT(S)

None.

### 2.3. NORMATIVE REFERENCES

Publication	Year	Title
FCC CFR Parts 0-19	2003	Code of Federal Regulations – Telecommunication
ANSI C63.4	2003	American National Standard for Methods of Measurement of Radio-Noise Emissions from Low-Voltage Electrical and Electronic Equipment in the Range of 9 kHz to 40 GHz
CISPR 22 & EN 55022	2003 2003	Limits and Methods of Measurements of Radio Disturbance Characteristics of Information Technology Equipment
CISPR 16-1	2003	Specification for Radio Disturbance and Immunity measuring apparatus and methods
FCC Public Notice DA 00-705	2000	Filing and Measurement Guidelines for Frequency Hopping Spread Spectrum Systems
FCC ET Docket No. 99-231	2002	Amendment to FCC Part 15 of the Commission's Rules Regarding to Spread Spectrum Devices

---

---

#### ULTRATECH GROUP OF LABS

3000 Bristol Circle, Oakville, Ontario, Canada L6H 6G4  
Tel. #: 905-829-1570, Fax. #: 905-829-8050, Email: [vic@ultratech-labs.com](mailto:vic@ultratech-labs.com), Website: <http://www.ultratech-labs.com>

File #: TEK-461F15C247  
September 2, 2004

All test results contained in this engineering test report are traceable to National Institute of Standards and Technology (NIST)

## EXHIBIT 3. PERFORMANCE ASSESSMENT

### 3.1. CLIENT INFORMATION

APPLICANT	
<b>Name:</b>	Psion Teklogix Inc.
<b>Address:</b>	2100 Meadowvale Blvd. Mississauga, ON Canada, L5N 7J9
<b>Contact Person:</b>	Mr. Sada Dharwarkar Phone #: 905-812-6200 (3358) Fax #: 905-812-6301 Email Address: <a href="mailto:sdharwar@teklogix.com">sdharwar@teklogix.com</a>

MANUFACTURER	
<b>Name:</b>	Psion Teklogix Inc.
<b>Address:</b>	2100 Meadowvale Blvd. Mississauga, ON Canada, L5N 7J9
<b>Contact Person:</b>	Mr. Sada Dharwarkar Phone #: 905-812-6200 (3358) Fax #: 905-812-6301 Email Address: <a href="mailto:sdharwar@teklogix.com">sdharwar@teklogix.com</a>

### 3.2. EQUIPMENT UNDER TEST (EUT) INFORMATION

The following information (with the exception of the Date of Receipt) has been supplied by the applicant.

<b>Brand Name:</b>	Psion Teklogix Inc.
<b>Product Name:</b>	WORKABOUT PRO (Handheld Computer)
<b>Model Name or Number:</b>	7525-RA2025
<b>Serial Number:</b>	Test Sample
<b>Type of Equipment:</b>	Digital Modulation Transmitters
<b>Input Power Supply Type:</b>	Internal Battery
<b>Primary User Functions of EUT:</b>	Provide data communication link through air

---

#### ULTRATECH GROUP OF LABS

3000 Bristol Circle, Oakville, Ontario, Canada L6H 6G4  
Tel. #: 905-829-1570, Fax. #: 905-829-8050, Email: [vic@ultratech-labs.com](mailto:vic@ultratech-labs.com), Website: <http://www.ultratech-labs.com>

File #: TEK-461F15C247  
September 2, 2004

All test results contained in this engineering test report are traceable to National Institute of Standards and Technology (NIST)

### 3.3. EUT’S TECHNICAL SPECIFICATIONS

<b>TRANSMITTER</b>	
<b>Equipment Type:</b>	Portable Transceiver
<b>Intended Operating Environment:</b>	Commercial, light industry & heavy industry
<b>Power Supply Requirement:</b>	7.4 Vdc
<b>RF Output Power Rating:</b>	0.0361 Watts
<b>Operating Frequency Range:</b>	2412 - 2462 MHz
<b>RF Output Impedance:</b>	50 Ohms
<b>Duty Cycle:</b>	100%
<b>Modulation Type:</b>	IEEE 802.11b: <ul style="list-style-type: none"> <li>• DBPSK for 1Mb/s Data Rate</li> <li>• DQPSK for 2 Mb/s Data Rate</li> <li>• CCK for 5.5 Mb/s Data Rate</li> <li>• CCK for 11 Mb/s Data Rate</li> </ul>
<b>Emission Designation:</b>	Digital Modulation
<b>Oscillator Frequencies:</b>	32.768 KHz, 6.0 MHz, 3.6864 MHz, 7.3728 MHz, 95.846 MHz, 147.46 MHz, 47.923 MHz, 31.949 MHz, 19.169 MHz, 14.746 MHz, 100 MHz, 200 MHz, 400 MHz
<b>Antenna Description:</b>	Manufacturer: Walsin Technology Corporation Model: RFANT 5220110A0T Frequency: 2400 MHz - 2500 MHz Type of Antenna: Monopole Ceramic Impedance: 50 Ohms Gain: 2 dBi

### 3.4. LIST OF EUT’S PORTS

Port Number	EUT’s Port Description	Number of Identical Ports	Connector Type	Cable Type (Shielded/Non-shielded)
1	*Tether Port	1		Shielded
2	Audio Jack	1		Shielded
3	Low Insertion Force Port (LIF)	1		N/A

\* The tether port is for manufacturer uses only.

## EXHIBIT 4. EUT OPERATING CONDITIONS AND CONFIGURATIONS DURING TESTS

### 4.1. CLIMATE TEST CONDITIONS

The climate conditions of the test environment are as follows:

Temperature:	21°C
Humidity:	51%
Pressure:	102 kPa
Power input source:	7.4 Vdc

### 4.2. OPERATIONAL TEST CONDITIONS & ARRANGEMENT FOR TESTS

<b>Operating Modes:</b>	Each of lowest, middle and highest channel frequencies transmits continuously for emissions measurements.
<b>Special Test Software:</b>	Special software is provided by the Applicant to select and operate the EUT at each channel frequency continuously. For example, the transmitter will be operated at each of lowest, middle and highest frequencies individually continuously during testing.
<b>Special Hardware Used:</b>	None.
<b>Transmitter Test Antenna:</b>	Internal integral antenna.

<b>Transmitter Test Signals</b>	
<b>Frequency Band(s):</b>	2412 - 2462 MHz
<b>Test Frequency(ies):</b> (Near lowest, near middle & near highest frequencies in the frequency range of operation.)	2412, 2437 & 2462 MHz
<b>Transmitter Wanted Output Test Signals:</b>	
Transmitter Power (measured maximum output power):	0.0361 Watts
Normal Test Modulation:	CCK @ 11 Mb/s
Modulating signal source:	Internal

### 4.3. DRAWING OF TEST SETUP

Stand-alone Device

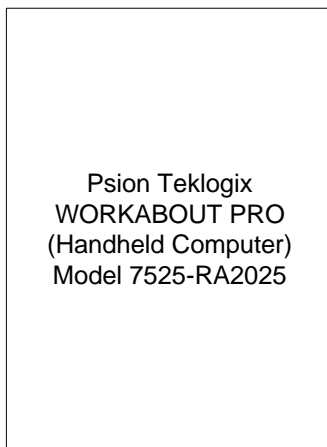



## EXHIBIT 5. SUMMARY OF TEST RESULTS

### 5.1. LOCATION OF TESTS

All of the measurements described in this report were performed at Ultratech Group of Labs located in the city of Oakville, Province of Ontario, Canada.

- AC Powerline Conducted Emissions were performed in UltraTech's shielded room, 16'(L) by 12'(W) by 12'(H).
- Radiated Emissions were performed at the Ultratech's 3 Meter Open Field Test Site (OFTS) situated in the Town of Oakville, province of Ontario.

The above sites have been calibrated in accordance with ANSI C63.4, and found to be in compliance with the requirements of Sec. 2.948 of the FCC Rules. The descriptions and site measurement data of the Oakville Open Field Test Site has been filed with FCC office (FCC File No.: 31040/SIT 1300B3) and Industry Canada office (Industry Canada File No.: IC2049). Last Date of Site Calibration: February 17, 2004.

### 5.2. APPLICABILITY & SUMMARY OF EMC EMISSION TEST RESULTS

FCC Paragraph	Test Requirements	Compliance (Yes/No)
FCC DA 00-1407	Un-licensed Modular Transmitter Approval Requirements	N/A
15.107(a) & 207	AC Power Conducted Emissions	N/A
15.247(a)(2)	6dB Bandwidth of a Digital Modulation System	Yes (See Note 1)
15.247(b) & 1.1310	Maximum Peak Power (Conducted)	Yes
1.1307, 1.1310, 2.1091 & 2.1093	RF Exposure Limit	Yes
15.247(c)	RF Conducted Spurious Emissions at the Transmitter Antenna Terminal	Yes (See Note 1)
15.247(c), 15.209 & 15.205	Transmitter Radiated Emissions	Yes
15.247(d)	Transmitted Power Density of a Digital Modulation System	Yes (See Note 1)
FCC Part 15, Sub. B, Sec. 15.109	Class B Radiated Emissions	Yes (See Note 2)

#### **Notes:**

1. See original filing test report for details (FCC ID: GM3RA2020M).
2. A separate engineering test report for compliance with FCC Part 15, Subpart B - Class B Unintentional Radiators is available upon request.

### 5.3. MODIFICATIONS INCORPORATED IN THE EUT FOR COMPLIANCE PURPOSES

None.

---

#### ULTRATECH GROUP OF LABS

3000 Bristol Circle, Oakville, Ontario, Canada L6H 6G4  
Tel. #: 905-829-1570, Fax. #: 905-829-8050, Email: [vic@ultratech-labs.com](mailto:vic@ultratech-labs.com), Website: <http://www.ultratech-labs.com>

File #: TEK-461F15C247  
September 2, 2004

*All test results contained in this engineering test report are traceable to National Institute of Standards and Technology (NIST)*

---

---

## **EXHIBIT 6. MEASUREMENTS, EXAMINATIONS & TEST DATA FOR EMC EMISSIONS**

### **6.1. TEST PROCEDURES**

This section contains test results only. Details of test methods and procedures can be found in Exhibit 8 of this report and ANSI C63-4.

### **6.2. MEASUREMENT UNCERTAINTIES**

The measurement uncertainties stated were calculated in accordance with requirements of UKAS Document NIS 81 with a confidence level of 95%. Please refer to Exhibit 7 for Measurement Uncertainties.

### **6.3. MEASUREMENT EQUIPMENT USED**

The measurement equipment used complied with the requirements of the Standards referenced in the Methods & Procedures ANSI C64-3, FCC 15.247 and CISPR 16-1.

### **6.4. ESSENTIAL/PRIMARY FUNCTIONS AS DECLARED BY THE MANUFACTURER**

The essential function of the EUT is to correctly communicate data to and from radios over RF link.

## 6.5. PEAK OUTPUT POWER (CONDUCTED) [§ 15.247(b)]

### 6.5.1. Limits

- **FCC 15.247(b)(3):** Maximum peak output power of the transmitter shall not exceed 1 Watt.
- **FCC 15.247(b)(4)(i):** If the device is not for fixed point to point radio, the antenna of directional gain greater than 6 dBi are used, the power shall be reduced by the amount in dB that the directional gain of the antenna exceeds 6 dBi.

### 6.5.2. Method of Measurements & Test Arrangement

Refer to Exhibit 8, Section. 8.2 of this test report, FCC 15.247(b)(1)&(3), ANSI C63. & ETSI 300 328

**Note:** The conducted peak power measurement method was performed in accordance with ETSI 300 328 since it was proven to be independent with the peak power meter characteristics.

### 6.5.3. Test Equipment List

Test Instruments	Manufacturer	Model No.	Serial No.	Frequency Range
Spectrum Analyzer/ EMI Receiver	Hewlett Packard	HP 8546A	...	9 kHz to 5.6 GHz with built-in 30 dB Gain Pre-selector, QP, Average & Peak Detectors.
67297 RF Detector (Diode Detector)	Herotex	DZ122-553	63400	..
Storage Oscilloscope	Philips	PM3320A	ST9907959	--

### 6.5.4. Test Data

Note: It was not possible to measure the conducted power for this device. Therefore, the test data below was obtained from original filing test results for this filing.

Transmitter Channel	Frequency (MHz)	(full bandwidth) Peak Power at Antenna Terminals (dBm)	Maximum Antenna Gain (dBi)	(full bandwidth) Peak EIRP (dBm)	Limit for Power at Antenna Port (dBm)	EIRP Limit (dBm)
Lowest	2412	14.6	0	14.6	30.0	36.0
Middle	2437	15.6	0	15.6	30.0	36.0
Highest	2462	13.8	0	13.8	30.0	36.0

**Remarks:** The above measurements were found to be the same for all different modulations such as below:

- DBPSK for 1Mb/s Data Rate
- DQPSK for 2 Mb/s Data Rate
- CCK for 5.5 Mb/s Data Rate
- CCK for 11 Mb/s Data Rate

**6.6. SPURIOUS EMISSIONS (RADIATED @ 3 METERS) [§§ 15.247(c), 15.209 & 15.205]**

**6.6.1. Limits**

In any 100 KHz bandwidth outside the operating frequency band, the radio frequency power that is produced by modulation products of the spreading sequence, the information sequence and the carrier frequency shall be either at least 20 dB below that in any 100 KHz bandwidth within the band that contains the highest level of the desired power or shall not exceed the general levels specified in @ 15.209(a), which lesser attenuation.

All other emissions inside restricted bands specified in @ 15.205(a) shall not exceed the general radiated emission limits specified in @ 15.209(a)

**Remarks:**

- Applies to harmonics/spurious emissions that fall in the restricted bands listed in Section 15.205. The maximum permitted average field strength is listed in Section 15.209.
- @ **FCC CFR 47, Para. 15.237(c)** - The emission limits as specified above are based on measurement instrument employing an average detector. The provisions in @**15.35** for limiting peak emissions apply.

**FCC CFR 47, Part 15, Subpart C, Para. 15.205(a) - Restricted Frequency Bands**

MHz	MHz	MHz	GHz
0.090 - 0.110	162.0125 - 167.17	2310 - 2390	9.3 - 9.5
0.49 - 0.51	167.72 - 173.2	2483.5 - 2500	10.6 - 12.7
2.1735 - 2.1905	240 - 285	2655 - 2900	13.25 - 13.4
8.362 - 8.366	322 - 335.4	3260 - 3267	14.47 - 14.5
13.36 - 13.41	399.9 - 410	3332 - 3339	14.35 - 16.2
25.5 - 25.67	608 - 614	3345.8 - 3358	17.7 - 21.4
37.5 - 38.25	960 - 1240	3600 - 4400	22.01 - 23.12
73 - 75.4	1300 - 1427	4500 - 5250	23.6 - 24.0
108 - 121.94	1435 - 1626.5	5350 - 5460	31.2 - 31.8
123 - 138	1660 - 1710	7250 - 7750	36.43 - 36.5
149.9 - 150.05	1718.8 - 1722.2	8025 - 8500	Above 38.6
156.7 - 156.9	2200 - 2300	9000 - 9200	

**FCC CFR 47, Part 15, Subpart C, Para. 15.209(a)  
 -- Field Strength Limits within Restricted Frequency Bands --**

FREQUENCY (MHz)	FIELD STRENGTH LIMITS (microvolts/m)	DISTANCE (Meters)
0.009 - 0.490	2,400 / F (KHz)	300
0.490 - 1.705	24,000 / F (KHz)	30
1.705 - 30.0	30	30
30 - 88	100	3
88 - 216	150	3
216 - 960	200	3
Above 960	500	3

### 6.6.2. Method of Measurements

Refer to Exhibit 8, Section 8.3 of this test report and ANSI 63.4 for detailed radiated emissions measurement procedures.

The following measurement procedures were also applied:

- Applies to harmonics/spurious that fall in the restricted bands listed in Section 15.205. the maximum permitted average field strength is listed in Section 15.209. A Pre-Amp and highpass filter are used for this measurement.
- For measurement below 1 GHz, set RBW = 100 KHz, VBW  $\geq$  100 KHz, SWEEP=AUTO.
- For measurement above 1 GHz, set RBW = 1 MHz, VBW = 1 MHz (Peak) & VBW = 10 Hz (Average), SWEEP=AUTO.
- If the emission is pulsed, modified the unit for continuous operation, then use the settings above for measurements, then correct the reading by subtracting the peak-average correction factor derived from the appropriate duty cycle calculation. See Section 15.35(b) and (c).

### 6.6.3. Test Arrangement

Please refer to Test Arrangement in Section. 4.3 for details of test setup for emission measurements.

### 6.6.4. Test Equipment List

Test Instruments	Manufacturer	Model No.	Serial No.	Frequency Range
Spectrum Analyzer	Rohde & Schwarz	FSEK20/B4/B21	834157/005	9 kHz- 40 GHz
Amplifier	Hewlett Packard	83051A	3611A01947	40 MHz – 50 GHz
Biconilog Antenna	EMCO	3143	1029	20 MHz to 2 GHz
Horn Antenna	EMCO	3155	9701-5061	1 GHz – 18 GHz
High Pass Filter	K & L	11SH10-4000/T12000	4	2 – 26 GHz

**6.6.5. Test Data**

**Remark:** Since the RF signal output are exactly identical with different modulations based on our prescans and IEEE 802.1 standard for DSSS, the CCK with 11 Mb/s data rate was chosen for the final tests.

**6.6.5.1. Lowest Frequency (2412 MHz)**

Frequency (MHz)	RF Peak Level (dBµV/m)	RF Avg Level (dBµV/m)	Antenna Plane (H/V)	Limit 15.209 (dBµV/m)	Limit 15.247 (dBµV/m)	Margin (dB)	Pass/Fail
2412.0	105.03	--	V	--	--	--	--
2412.0	108.88	--	H	--	--	--	--
4824.0	59.21	44.93	V	54.0	88.9	-9.1	Pass*
4824.0	60.81	47.01	H	54.0	88.9	-7.0	Pass*

- The emissions were scanned from 10 MHz to 25 GHz and all emissions less 20 dB below the limits were recorded.
- Please refer to Plot # 1 and 2 for Band-Edge Radiated Emissions measured at 3 meters.

\* Frequency in restricted bands, therefore FCC 15.209 limit applied.

**Plot #1: Lower Band-Edge Radiated Emissions @ 3 Meters (Horizontal Polarization)**

**Frequency: 2412 MHz, 11 Mbps, Delta Trace 1 & Trace 2: 7.90 dB**  
**Trace 1: RBW= 1 MHz, VBW= 3 MHz**  
**Trace 2: RBW= 100 kHz, VBW= 1 MHz**

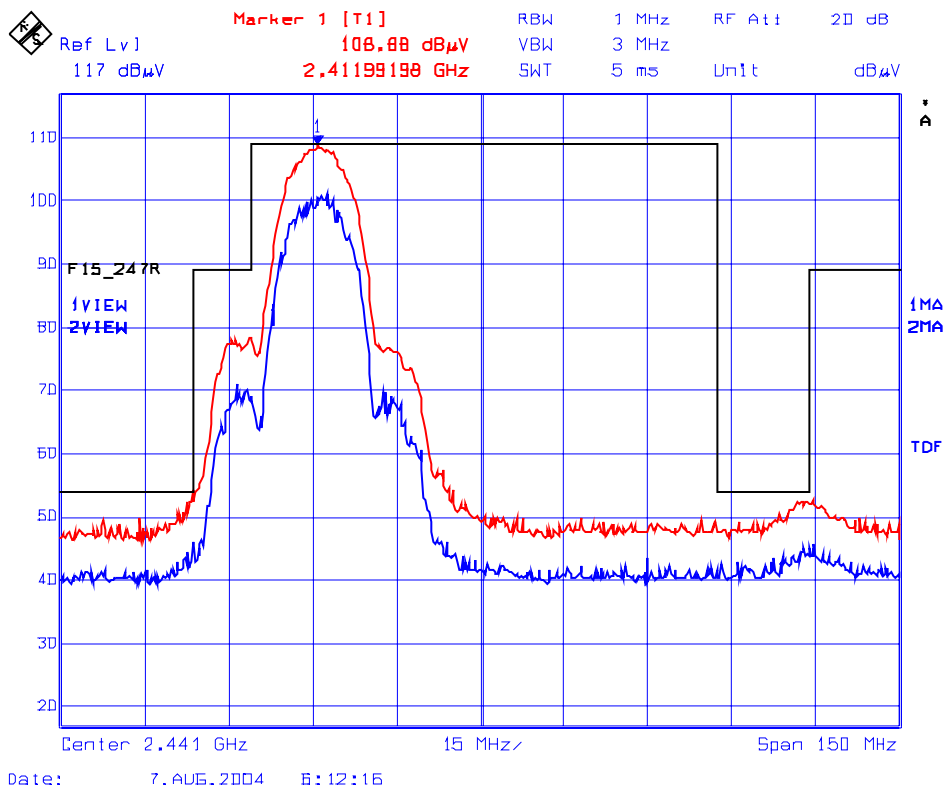

**Plot #2: Lower Band-Edge Radiated Emissions @ 3 Meters (Vertical Polarization)**

**Frequency: 2412 MHz, 11 Mbps, Delta Trace 1 & Trace 2: 7.63 dB**  
**Trace 1: RBW= 1 MHz, VBW= 3 MHz**  
**Trace 2: RBW= 100 kHz, VBW= 1 MHz**

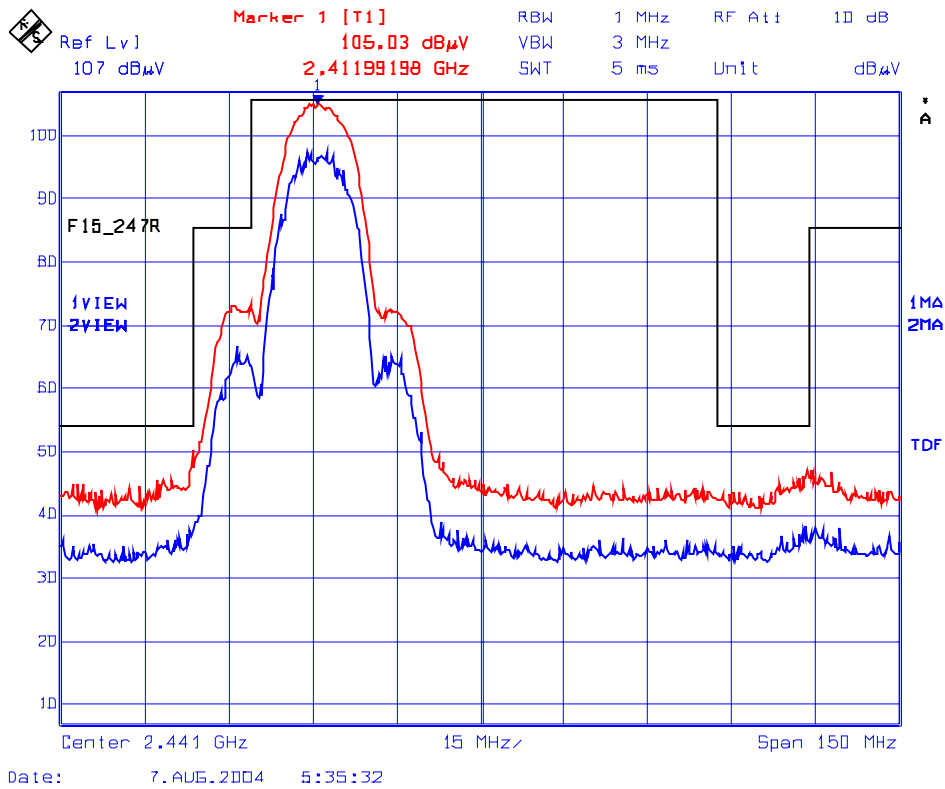



**6.6.5.2. Middle Frequency (2437 MHz)**

Frequency (MHz)	RF Peak Level (dBµV/m)	RF Avg Level (dBµV/m)	Antenna Plane (H/V)	Limit 15.209 (dBµV/m)	Limit 15.247 (dBµV/m)	Margin (dB)	Pass/Fail
2437.00	105.78	--	V	--	--	--	--
2437.00	108.89	--	H	--	--	--	--
4874.00	58.59	44.42	V	54.0	88.9	-9.6	Pass*
4874.00	59.22	44.98	H	54.0	88.9	-9.0	Pass*

The emissions were scanned from 10 MHz to 25 GHz and all emissions less 20 dB below the limits were recorded.

\* Frequency in restricted bands, therefore FCC 15.209 limit applied.

**6.6.5.3. Highest Frequency (2462 MHz)**

Frequency (MHz)	RF Peak Level (dBµV/m)	RF Avg Level (dBµV/m)	Antenna Plane (H/V)	Limit 15.209 (dBµV/m)	Limit 15.247 (dBµV/m)	Margin (dB)	Pass/Fail
2462.00	106.20	--	V	--	--	--	--
2462.00	108.76	--	H	--	--	--	--
4924.00	59.29	45.88	V	54.0	88.8	-8.1	Pass*
4924.00	62.28	48.80	H	54.0	88.8	-5.2	Pass*

- The emissions were scanned from 10 MHz to 25 GHz and all emissions less 20 dB below the limits were recorded.
- Please refer to Plot # 3 and 4 for Band-Edge Radiated Emissions measured at 3 meters.

\* Frequency in restricted bands, therefore FCC 15.209 limit applied.

**Plot #3: Upper Band-Edge Radiated Emissions @ 3 Meters (Horizontal Polarization)**

**Frequency: 2462 MHz, 11 Mbps, Delta Trace 1 & Trace 2: 8.33 dB**  
**Trace 1: RBW= 1 MHz, VBW= 3 MHz**  
**Trace 2: RBW= 100 kHz, VBW= 1 MHz**

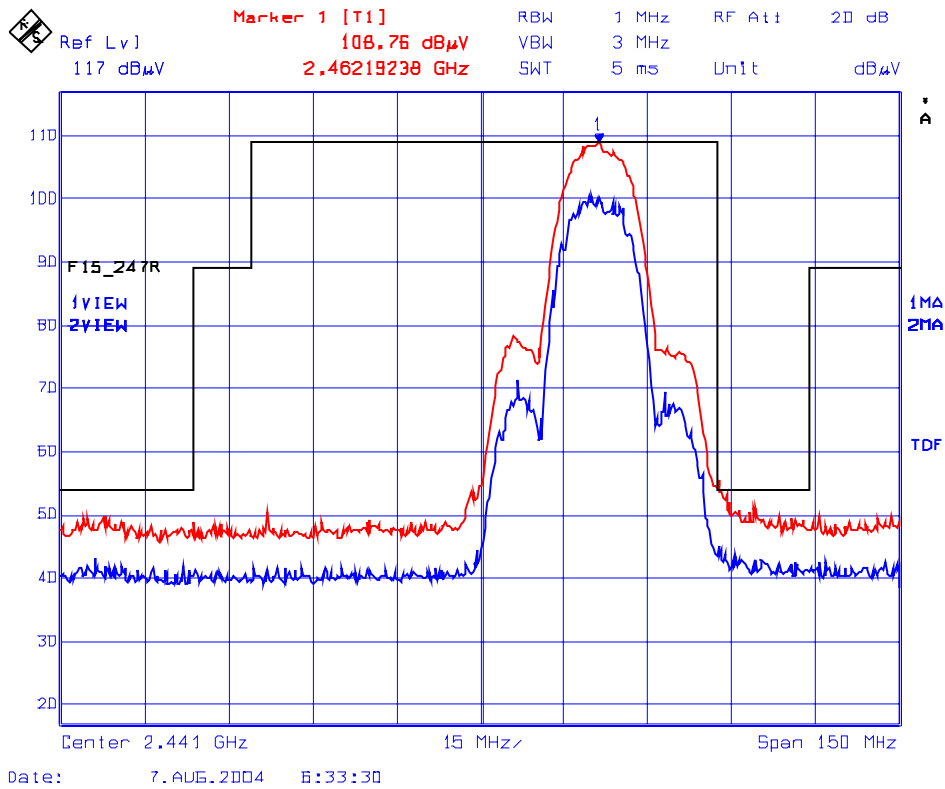

**Plot #4: Upper Band-Edge Radiated Emissions @ 3 Meters (Vertical Polarization)**

**Frequency: 2462 MHz, 11 Mbps, Delta Trace 1 & Trace 2: 7.62 dB**  
**Trace 1: RBW= 1 MHz, VBW= 3 MHz**  
**Trace 2: RBW= 100 kHz, VBW= 1 MHz**

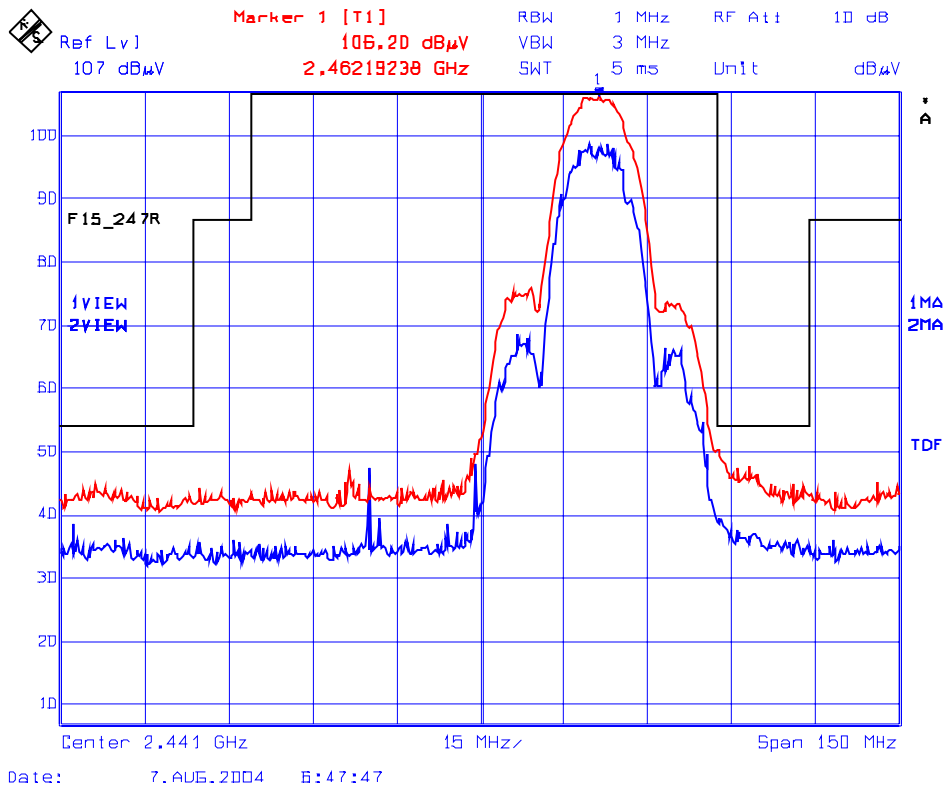

## EXHIBIT 7. MEASUREMENT UNCERTAINTY

The measurement uncertainties stated were calculated in accordance with the requirements of NIST Technical Note 1297 and NIS 81 (1994)

### 7.1. LINE CONDUCTED EMISSION MEASUREMENT UNCERTAINTY

CONTRIBUTION (Line Conducted)	PROBABILITY DISTRIBUTION	UNCERTAINTY (dB)	
		9-150 kHz	0.15-30 MHz
EMI Receiver specification	Rectangular	$\pm 1.5$	$\pm 1.5$
LISN coupling specification	Rectangular	$\pm 1.5$	$\pm 1.5$
Cable and Input Transient Limiter calibration	Normal (k=2)	$\pm 0.3$	$\pm 0.5$
Mismatch: Receiver VRC $\Gamma_1 = 0.03$ LISN VRC $\Gamma_R = 0.8(9 \text{ kHz}) 0.2 (30 \text{ MHz})$ Uncertainty limits $20\text{Log}(1+\Gamma_1\Gamma_R)$	U-Shaped	$\pm 0.2$	$\pm 0.3$
System repeatability	Std. deviation	$\pm 0.2$	$\pm 0.05$
Repeatability of EUT	--	--	--
Combined standard uncertainty	Normal	$\pm 1.25$	$\pm 1.30$
Expanded uncertainty U	Normal (k=2)	$\pm 2.50$	$\pm 2.60$

Sample Calculation for Measurement Accuracy in 450 kHz to 30 MHz Band:

$$u_c(y) = \sqrt{\sum_{i=1}^m u_i^2(y)} = \pm \sqrt{(1.5^2 + 1.5^2)/3 + (0.5/2)^2 + (0.05/2)^2 + 0.35^2} = \pm 1.30 \text{ dB}$$

$$U = 2u_c(y) = \pm 2.6 \text{ dB}$$

## 7.2. RADIATED EMISSION MEASUREMENT UNCERTAINTY

CONTRIBUTION (Radiated Emissions)	PROBABILITY DISTRIBUTION	UNCERTAINTY (+ dB)	
		3 m	10 m
Antenna Factor Calibration	Normal (k=2)	$\pm 1.0$	$\pm 1.0$
Cable Loss Calibration	Normal (k=2)	$\pm 0.3$	$\pm 0.5$
EMI Receiver specification	Rectangular	$\pm 1.5$	$\pm 1.5$
Antenna Directivity	Rectangular	+0.5	+0.5
Antenna factor variation with height	Rectangular	$\pm 2.0$	$\pm 0.5$
Antenna phase center variation	Rectangular	0.0	$\pm 0.2$
Antenna factor frequency interpolation	Rectangular	$\pm 0.25$	$\pm 0.25$
Measurement distance variation	Rectangular	$\pm 0.6$	$\pm 0.4$
Site imperfections	Rectangular	$\pm 2.0$	$\pm 2.0$
Mismatch: Receiver VRC $\Gamma_1 = 0.2$ Antenna VRC $\Gamma_R = 0.67(Bi) 0.3 (Lp)$ Uncertainty limits $20\text{Log}(1+\Gamma_1\Gamma_R)$	U-Shaped	+1.1 -1.25	$\pm 0.5$
System repeatability	Std. Deviation	$\pm 0.5$	$\pm 0.5$
Repeatability of EUT		-	-
Combined standard uncertainty	Normal	+2.19 / -2.21	+1.74 / -1.72
Expanded uncertainty U	Normal (k=2)	+4.38 / -4.42	+3.48 / -3.44

Calculation for maximum uncertainty when 3m biconical antenna including a factor of k=2 is used:

$$U = 2u_c(y) = 2x(+2.19) = +4.38 \text{ dB} \quad \text{and} \quad U = 2u_c(y) = 2x(-2.21) = -4.42 \text{ dB}$$

## EXHIBIT 8. MEASUREMENT METHODS

### 8.1. GENERAL TEST CONDITIONS

The following test conditions shall be applied throughout the tests covered in this report.

#### 8.1.1. Normal temperature and humidity

- Normal temperature: +15°C to +35°C
- Relative Humidity: +20% to 75%

The actual values during tests shall be recorded in the test report.

#### 8.1.2. Normal power source

##### 8.1.2.1. Mains Voltage

The nominal test voltage of the equipment to be connected to mains shall be the nominal mains voltage which is the declared voltage or any of the declared voltages for which the equipment was designed. The frequency of test power source corresponding to the AC mains shall be between 59 Hz and 61 Hz.

##### 8.1.2.2. Battery Power Source.

For operation from battery power sources, the nominal test voltage shall be as declared by the equipment manufacturer. This shall be recorded in the test report.

#### 8.1.3. Operating Condition of Equipment under Test

- All tests were carried out while the equipment operated at the following frequencies:
  - The lowest operating frequency,
  - The middle operating frequency and
  - The highest operating frequency
- Modulation were applied using the Test Data sequence
- The transmitter was operated at the highest output power, or in the case the equipment able to operate at more than one power level, at the lowest and highest output powers

## 8.2. PEAK CONDUCTED POWER & PEAK EIRP

### 8.2.1. Measurements of Transmitter Parameters (Duty Cycle & Peak Power)

- The following shall be applied to the combination(s) of the radio device and its intended antenna(e).
- If the RF level is user adjustable, all measurements shall be made with the highest power level available to the user for that combination.
- The following method of measurement shall apply to both conducted and radiated measurements.
- The radiated measurements are performed at the Ultratech Calibrated Open Field Test Site.
- The measurement shall be performed using normal operation of the equipment with modulation.

Test procedure shall be as follows:

#### Step 1: Duty Cycle (x) and Peak Power (y) parameters measurements

- Connect the transmitter output to a diode detector through an attenuator
- Connect the diode detector to the vertical channel of an oscilloscope.
- The observed duty cycle of the transmitter,  $x = \text{Tx on} / (\text{Tx on} + \text{Tx off})$  with  $0 < x < 1$ , is measure and recorded in the test report. For the purpose of testing, the equipment shall be operated with a duty cycle that is equal or more than 0.1.
- Observe and record the y parameter of the DC level on the oscilloscope.

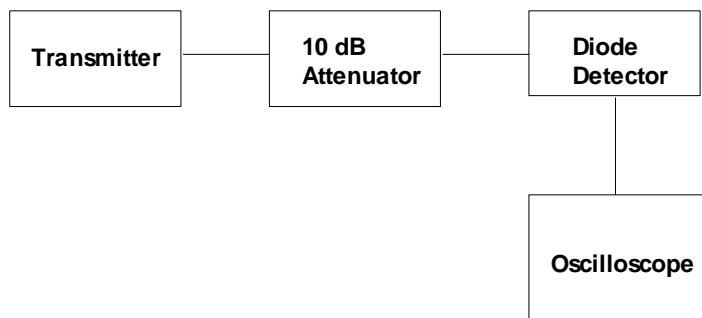

**Step 2: Peak Power Measurements**

- Replace the transmitter by a RF signal generator
- Set the signal generator frequency be the same as the transmitter frequency
- Adjust the rf output level of the RF signal generator until the DC level on the oscilloscope is same as that (y) recorded in step 1.
- Measure the RF signal generator output level using a power meter
- Calculate the total peak power (Pp) by adding the signal generator level with the attenuator value and the cable loss.

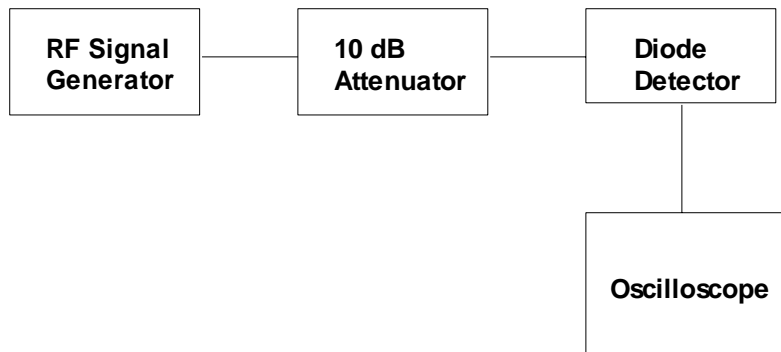

**Step 3: Total Peak EIRP Substitution Method. See Figure 2**

- (a) The setting of the spectrum analyzer shall be:

Center Frequency: equal to the signal source  
Resolution BW: 100 kHz for FSS, 1 MHz for DIGITAL MODULATION  
Video BW: same  
Detector Mode: positive  
Average: off  
Span: 3 x the signal bandwidth

- (b) Connect the transmitter output to the spectrum analyzer and measure the peak power in 1 MHz bandwidth for reference.
- (c) Calculate the difference (Kp) between the total peak power and 1 MHz BW peak power. This value will be used to add onto the 1MHz BW peak EIRP to obtain the TOTAL peak EIRP.
- (d) Test was performed at listed 3m open area test site (listed with FCC, IC, ITI, NVLAP, ACA & VCCI).
- (e) The transmitter under test was placed at the specified height on a non-conducting turntable (80 cm height)
- (f) The horn test antenna was used and tuned to the transmitter carrier frequency.
- (g) The spectrum analyzer was tuned to transmitter carrier frequency. The test antenna was lowered or raised from 1 to 4 meters until the maximum signal level was detected.
- (h) The transmitter was rotated through 360° about a vertical axis until a higher maximum signal was received.
- (i) The test antenna was lowered or raised again from 1 to 4 meters until a maximum was obtained. This level was recorded.
- (j) The substitution horn antenna and the signal generator replaced the transmitter and antenna under test in the same position, and the substitution horn antenna was placed in vertical polarization. The test horn antenna was lowered or raised as necessary to ensure that the maximum signal is stilled received.



- (k) The input signal to the substitution antenna was adjusted in level until an equal or a known related level to that detected from the transmitter was obtained in the test receiver. The maximum carrier radiated power is equal to the power supply by the generator.
- (l) The substitution antenna gain and cable loss were added to the signal generator level for the corrected 1MHz BW peak EIRP level. The total peak EIRP can be calculated by adding its value with the Kp
- (m) Repeat steps (c) to (j) with the substitution antenna oriented in horizontal polarization. Measured in step (c).
- (n) Actual gain of the EUT's antenna is the difference of the measured ERP and measured RF power at the RF port. Correct the antenna gain if necessary.

Figure 2

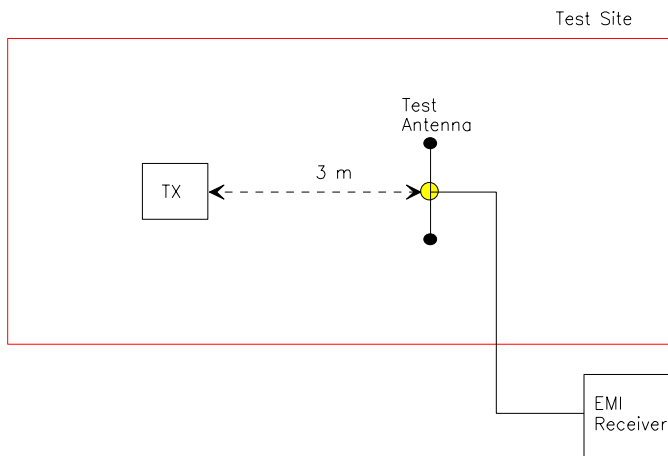
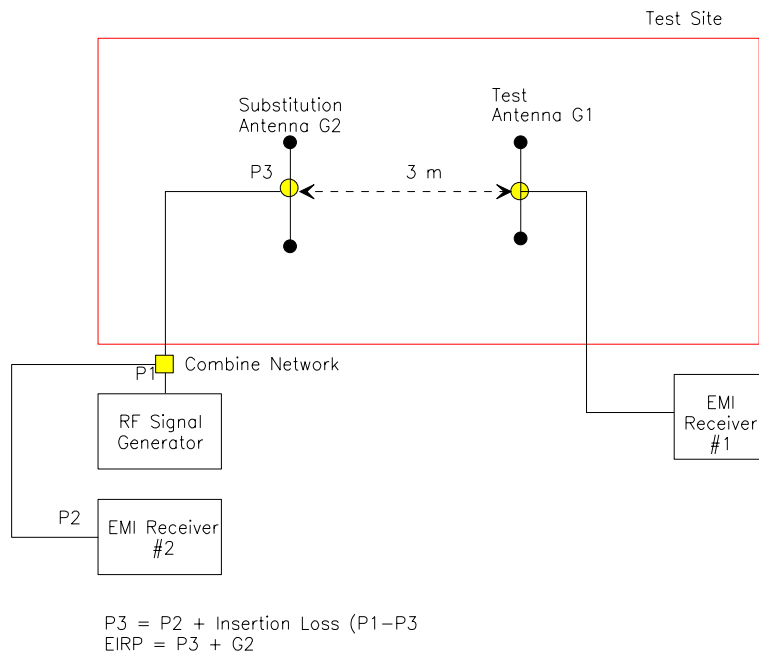

Figure 3



### 8.3. SPURIOUS EMISSIONS (CONDUCTED & RADIATED)

For both conducted and radiated measurements, the spurious emissions were scanned from the lowest frequency generated by the EUT or 10 MHz whichever is lower to 10<sup>th</sup> harmonic of the highest frequency generated by the EUT.

#### 8.3.1. Band-edge and Spurious Emissions (Conducted)

##### Band-edge Compliance of RF Conducted Emissions:

Use the following spectrum analyzer settings:

- The radio was connected to the measuring equipment via a suitable attenuator.
- Span = wide enough to capture the peak level of the emission operating on the channel closest to the band-edge, as well as any modulation products which fall outside of the authorized band of operation.
- RBW = 1 % of the span
- VBW = RBW
- Sweep = auto
- Detector function = peak
- Trace = max hold
- Allow the trace to stabilize
- Set the marker on the emission at the band-edge, or on the highest modulation product outside of the band, if this level is greater than that at the band-edge
- Enable the marker-delta function, then use the marker-to-peak function to move the marker to the peak of the in-band emission.
- The marker-delta value now displayed must comply with the limit specified
- Submit this plot

##### Spurious RF Conducted Emissions:

Use the following spectrum analyzer settings:

- The radio was connected to the measuring equipment via a suitable attenuator.
- Span = wide enough to capture the peak level of the in-band-emission and all spurious emissions (e.g. harmonics) from the lowest frequency generated in the EUT up through the 10<sup>th</sup> harmonic. Typically, several plots are required to cover this entire span.
- RBW = 100 kHz
- VBW = RBW
- Sweep = auto
- Detector function = peak
- Trace = max hold
- Allow the trace to stabilize
- Set the marker on the any spurious emission recorded. The level displayed must comply with the limit specified in this Section.
- Submit this plot

### 8.3.2. Spurious Emissions (Radiated)

- The radiated emission measurements were performed at the UltraTech's 3 Meter Open Field Test Site (OFTS) situated in the Town of Oakville, province of Ontario. The Attenuation Characteristics of OFTS have been filed to FCC, Industry Canada, ACA/Austel, NVLap and ITI.
- Radiated emissions measurements were made using the following test instruments:
  1. Calibrated EMCO BiconiLog antenna in the frequency range from 30 MHz to 2000 MHz.
  2. Calibrated Emco Horn antennas in the frequency range above 1000 MHz (1GHz - 40 GHz).
  3. The test is required for any spurious emission or modulation product that falls in a Restricted Band, as defined in Section 15.205. It must be performed with the highest gain of each type of antenna proposed for use with the EUT. Use the following spectrum analyzer settings:
    - RBW = 100 kHz for  $f < 1\text{GHz}$  and RBW = 1 MHz for  $f \geq 1\text{ GHz}$
    - VBW = RBW
    - Sweep = auto
    - Detector function = peak
    - Trace = max hold
    - Follows the guidelines in ANSI C63.4-1992 with respect to maximizing the emission by rotating the EUT, measuring the emission while the EUT is situated in three orthogonal planes (if appropriate), adjusting the measurement antenna height and polarization, etc.. A pre-amp and highpass filter are required for this test, in order to provide the measuring system with sufficient sensitivity.
    - Allow the trace to stabilize.
    - The peak reading of the emission, after being corrected by the antenna correction factor, cable loss, pre-amp gain, etc.... is the peak field strength which comply with the limit specified in Section 15.35(b)

#### Calculation of Field Strength:

The field strength is calculated by adding the calibrated antenna factor and cable factor, and subtracting the Amplifier gain (if any) from the measured reading. The basic equation with a sample calculation is as follows:

$$FS = RA + AF + CF - AG$$

Where FS = Field Strength  
RA = Receiver/Analyzer Reading  
AF = Antenna Factor  
CF = Cable Attenuation Factor  
AG = Amplifier Gain

Example: If a receiver reading of 60.0 dBuV is obtained, the antenna factor of 7.0 dB/m and cable factor of 1.0 dB are added, and the amplifier gain of 30 dB is subtracted. The actual field strength will be:

Field Level =  $60 + 7.0 + 1.0 - 30 = 38.0$  dBuV/m.

Field Level =  $10^{(38/20)} = 79.43$  uV/m.

- Submit this test data
- Now set the VBW to 10Hz, while maintaining all of the other instrument settings. This peak level, once corrected, must comply with the limit specified in Section 15.209. If the dwell time of the each channel is less than 100ms, then the reading obtained may be further adjusted by a “duty cycle correction factor”, derived from  $10\log(\text{dwell time}/100\text{mS})$  in an effort to demonstrate compliance with the 15.209.
- Submit test data

### **Maximizing The Radiated Emissions:**

- The frequencies of emissions was first detected. Then the amplitude of the emissions was measured at the specified measurement distance using required antenna height, polarization, and detector characteristics.
- During this process, cables and peripheral devices were manipulated within the range of likely configuration.
- For each mode of operation required to be tested, the frequency spectrum was monitored. Variations in antenna heights (from 1 meter to 4 meters above the ground plane), antenna polarization (horizontal plane and vertical plane), cable placement and peripheral placement were explored to produce the highest amplitude signal relative to the limit.

The maximum radiated emission for a given mode of operation was found by using the following step-by-step procedure:

- Step 1: Monitor the frequency range of interest at a fixed antenna height and EUT azimuth.
- Step 2: Manipulate the system cables to produce highest amplitude signal relative to the limit. Note the amplitude and frequency of the suspect signal.
- Step 3: Rotate the EUT 360 degrees to maximize the suspected highest amplitude signal. If the signal or another at a different frequency is observed to exceed the previously noted highest amplitude signal by 1 dB or more, go back to the azimuth and repeat Step 2. Otherwise, orient the EUT azimuth to repeat the highest amplitude observation and proceed.
- Step 4: Move the antenna over its full allowable range of travel (1 to 4 meters) to maximize the suspected highest amplitude signal. If the signal or another at a different frequency is observed to exceed the previously noted highest amplitude signal by 1 dB or more, return to Step 2 with the highest amplitude observation and proceed.
- Step 5: Change the polarization of the antenna and repeat Step 2 through 4. Compare the resulting suspected highest amplitude signal with that found for the other polarization. Select and note the higher of the two signals. This signal is termed the highest observed signal with respect to the limit for this EUT operational mode.
- Step 6: The effects of various modes of operation is examined. This is done by varying the equipment modes as steps 2 through 5 are being performed.
- Step 7: After completing steps 1 through 6, record the final highest emission level, frequency, antenna polarization and detector mode of the measuring instrument.

## 8.4. ALTERNATIVE TEST PROCEDURES

If the antenna conducted tests cannot be performed on this device, radiated tests show compliance with the peak output power limit specified in Section 15.247(b) and the spurious RF conducted emission limit specified in Section 15.247(c) are acceptable. As stated previously, a pre-amp, and, in the later case, a high pass filter, are required for the following measurements:

### 8.4.1. Peak Power Measurements

Calculate the transmitter's peak power using the following equation:

$$E = 30PG/d$$
$$P = (Ed)^2/30G$$

Where:

- E: measured maximum fundamental field strength in V/m. Utilizing a RBW, the 20 dB bandwidth of the emission  $VBW > RBW$ , peak detector function. Follow the procedures in C63.4 with respect to maximizing the emission
- G is numeric gain of the transmitting antenna with reference to an isotropic radiator
- D is the distance in meters from which the field strength was measured
- P is the distance in meters from which the field strength was measured

### 8.4.2. Spurious RF conducted emissions

To demonstrate compliance with the spurious RF conducted emission requirement of Section 15.247©, use the following spectrum analyzer settings:

- Span = wide enough to fully capture the emission being measured
- RBW = 100 kHz
- Sweep = auto
- Detector function = peak
- Trace = max hold
- Measure the field strength of both the fundamental and all spurious emissions with these settings.
- Follow the procedures C62-4 with respect to maximizing the emissions. The measured field strength of all spurious emissions must be below the measured field strength of the fundamental emission by the amount specified in Section 15.247©. Note that if the emission falls in a Restricted Band, as defined in Section 15.205, the procedure for measuring spurious radiated emissions listed above must be followed