

FCC / IC TEST REPORT

for

47 CFR Part 15 Subpart C and RSS-210

Equipment : Bluetooth module
Trade Name : WORKABOUT PRO
Model No. : BTL040
FCC ID : GM37525BTB
IC ID : 2739D-7525BTB
Filing Type : PC II Change
Applicant : Psion Teklogix Inc.
2100 Meadowvale Blvd, Mississauga, Ontario, L5N 7J9, Canada

- The test result refers exclusively to the test presented test model / sample.
- Without written approval of SPORTON International Inc., the test report shall not be reproduced except in full.
- **Certificate or Test Report must not be used by the applicant to claim the product in this test report endorsement by NVLAP or any agency of U.S. government.**
- The data shown in this test report were carried out on Dec. 06~07, 13~14, 2005 and Jan. 28, 2008 at **Sporton International Inc. LAB.**
- Report No.: FR5D0903-03, Report Version: Rev. 01.

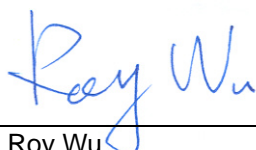

Roy Wu
Manager

SPORTON International Inc.

6F, No.106, Sec. 1, Hsin Tai Wu Rd., Hsi Chih, Taipei Hsien, Taiwan, R.O.C.

SPORTON International Inc.

TEL : 886-2-2696-2468

FAX : 886-2-2696-2255

Report Version: Rev. 01

FCC ID : GM37525BTB
IC ID : 2739D-7525BTB



Table of Contents

History of this test report..... ii

1. General Description of Equipment under Test..... 1

 1.1.Applicant..... 1

 1.2.Manufacturer 1

 1.3.Basic Description of Equipment under Test..... 1

 1.4.Feature of Equipment under Test 2

2. Test Configuration of Equipment under Test 4

 2.1.Test Manner 4

 2.2.Test Mode 4

 2.3.Connection Diagram of Test System 5

 2.4.Ancillary Equipment List..... 5

3. RF Utility 6

4. General Information of Test..... 7

 4.1.Test Voltage 7

 4.2.Standard for Methods of Measurement..... 7

 4.3.Test in Compliance with 7

 4.4.Frequency Range Investigated 7

 4.5.Test Distance 7

5. Report of Measurements and Examinations 8

 5.1.List of Measurements and Examinations 8

 5.2.Hopping Channel Separation 9

 5.3.Number of Hopping Frequency 13

 5.5 Dwell Time of Each Frequency within a 30 Seconds Period 19

 5.6 Output Power 39

 5.7 100kHz Bandwidth of Frequency Band Edges 43

 5.8 Conducted Emission 47

 5.9 Radiated Emission Measurement 50

 5.10 Antenna Requirements..... 68

6. List of Measuring Equipment 69

7. Uncertainty Evaluation..... 70

Appendix A. External Product Photograph

Appendix B. Internal Photograph

Appendix C. Setup Photograph



1. General Description of Equipment under Test

1.1. Applicant

Psion Teklogix Inc.
2100 Meadowvale Blvd, Mississauga, Ontario, L5N 7J9, Canada

1.2. Manufacturer

ASKEY COMPUTER CORP.
10F, No. 119, Chienkang Rd., Chung-Ho, Taipei, Taiwan, R.O.C.

1.3. Basic Description of Equipment under Test

Equipment	Bluetooth module	
Trade Name	WORKABOUT PRO	
Model Name	BTL040	
FCC ID	GM37525BTB	
IC ID	2739D-7525BTB	
Power Supply Type	From Host PSION TEKLOGIX PDA 7525C	
AC Adapter 1	Brand Name	LI SHIN
	Model Name	LSE9912B0515
	Power Rating	I/P:100-240Vac, 50-60Hz, 0.6A; O/P: 5Vdc, 3.0A
	AC Power Cord Type	1.8 meter non-shielded cable with ferrite core
AC Adapter 2	Brand Name	Phihong
	Model Name	PSA15R-050P
	Power Rating	I/P:100-240Vac, 50-60Hz, 0.5A; O/P: 5.0Vdc, 3.0A
	AC Power Cord Type	1.8 meter shielded cable with ferrite core
Battery	Brand Name	PSION TEKLOGIX
	Model Name	WA3006
	Power Rating	3.7Vdc, 3000mAh
	Type	Li-ion
Car Charger	Brand Name	PSION TEKLOGIX
	Model Name	WA3112-G1
	Power Rating	I/P:10-30Vac, 1.3A; O/P: 5Vdc, 2A
Docking Station	Brand Name	PSION TEKLOGIX
	Model Name	WA4003-G2
	Power Rating	5Vdc, 3A

Remark: Above EUT's information was declared by manufacturer. Please refer to the specifications of manufacturer or User's Manual for more detailed features description.



1.4. Feature of Equipment under Test

BT Module

Product Feature & Specification			
1. Modulation Type/Data Rate	GFSK		
2. Frequency Range.	2400 MHz ~ 2483.5 MHz		
3. Number of Channels	79		
4. Carrier Frequency of each channel	2402+ n*1 MHz, n= 0~78		
5. Channel Spacing	1 MHz		
6. Maximum Output Power to Antenna (Normal condition)	3.28 dBm		
7. Type of Antenna Connector	UML		
8. Antenna Type	a. Dipole Antenna b. PIFA Antenna		
9. Antenna Gain	a. 3.89 dBi b. 0.25 dBi		
10. Function Type	Transmitter		Transceiver V
11. Power Rating (DC/AC , Voltage)	120Vac / 60Hz		

**Co-transmission WLAN Card**

Product Feature & Specification	
1. Model Name	WLF010 / RA2015
2. FCC ID	H8NWLF010
3. Type of Modulation	DSSS
4. Frequency Range	2400 ~ 2483.5 MHz
5. Number of Channels	11
6. Carrier Frequency of Each Channel	$2412+(n-1)*5$ MHz; n=1~11
7. Antenna Connector	N/A
8. Antenna Type	Fixed Internal
9. Antenna Gain	2.5 dBi
10. Maximum Output Power	13.36 dBm
11. DUT Stage	Production Unit
12. Application Type	PC II Change



2. Test Configuration of Equipment under Test

2.1. Test Manner

- a. The EUT has been associated with peripherals pursuant to ANSI C63.4-2003 and configuration operated in a manner tended to maximize its emission characteristics in a typical application.
- b. For spurious emission below 1GHz, only one channel of each application was tested because it is not related to channel selection.
- c. The EUT is programmed to transmit signal continuously for all testings.
- d. Frequency range investigated: conduction 150 kHz to 30 MHz, radiation 30 MHz to 25000MHz.

2.2. Test Mode

Application	Bluetooth
Radiated Emission and conducted test items	Mode 1: Tx_CH00_2402 MHz for Dipole Antenna for 7525C with old panel Mode 2: Tx_CH39_2441 MHz for Dipole Antenna for 7525C with old panel Mode 3: Tx_CH78_2480 MHz for Dipole Antenna for 7525C with old panel Mode 4: Tx_CH00_2402 MHz for PIFA Antenna for 7525C with old panel Mode 5: Tx_CH00_2402 MHz with WLAN Tx_CH11_2462 Co-location for WLF010 / RA2015 for 7525C with old panel Mode 6: Tx_CH00_2402 MHz for Dipole Antenna for 7525C with new panel Mode7: Tx_CH39_2441 MHz for Dipole Antenna for 7525C with new panel Mode8: Tx_CH78_2480 MHz for Dipole Antenna for 7525C with new panel Mode9: Tx_CH78_2480 MHz for Dipole Antenna for 7525S with new panel
Conducted Emission	Mode 1: Rx _CH39_2441 MHz

Remark:

- 1. The maximum power channel, CH00, was verified for PIFA antenna and found there is no worse result.
- 2. Radiated spurious emission was verified on BT and WLAN co-transmission mode.

2.3. Connection Diagram of Test System

<Mode 1~4>

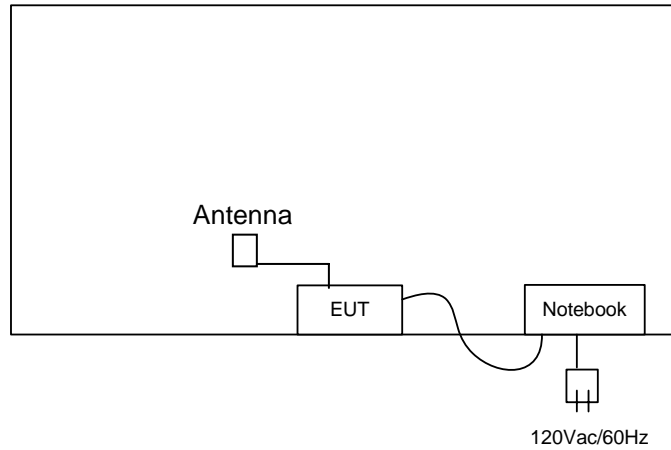

<Mode 5~9>

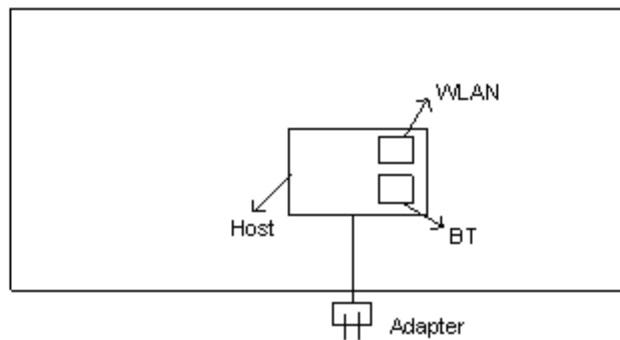

2.4. Ancillary Equipment List

Item	Equipment	Trade Name	Model Name	FCC ID	Data Cable / Power Cord
1.	Notebook	DELL	D400	E2K24GBRL	Unshielded, 1.2m
2.	USB Cable	N/A	N/A	N/A	Unshielded, 1.5m
3.	Host PDA	N/A	7525C	N/A	N/A
4.	Host PDA	N/A	7525S	N/A	N/A



3. RF Utility

Programmed RF utility "Bluetest" can transmit continuous Tx signal.

WLAN card is in the EUT and BT are in continuous Tx mode thru RF test utility.



4. General Information of Test

Test Site Location : No. 52, Hwa Ya 1st Rd., Hwa Ya Technology Park,
Kwei-Shan Hsiang, Tao Yuan Hsien, Taiwan, R.O.C.
TEL : 886-3-327-3456
FAX : 886-3-318-0055
Test Site No : CO01-HY, 03CH06-HY

4.1. Test Voltage

AC 120V

4.2. Standard for Methods of Measurement

ANSI C63.4-2003

4.3. Test in Compliance with

47 CFR Part 15 Subpart C and RSS-210

4.4. Frequency Range Investigated

Conduction: from 150 kHz to 30 MHz
Radiation: from 30 MHz to 25000MHz

4.5. Test Distance

The test distance of radiated emission from antenna to EUT is 3 m.



5. Report of Measurements and Examinations

5.1. List of Measurements and Examinations

FCC Rule	IC Rule	Description of Test	Result	Section
15.247(a)(1)	6.2.2 (o)(a3)	Hopping Channel Separation	Pass	5.2
15.247(a)(1)(iii)	6.2.2 (o)(a3)	Number of Hopping Frequency Used	Pass	5.3
15.247(a)(1)	6.2.2 (o)(a3)	Hopping Channel Bandwidth	Pass	5.4
15.247(a)(1)(iii)	6.2.2 (o)(a3)	Dwell Time of Each Frequency within a 30 Second Period	Pass	5.5
15.247(b)(1)	6.2.2(o)(a3) & Amendment 1	Output Power	Pass	5.6
15.247(c)	6.2.2 (o)(e1)	100kHz Bandwidth of Frequency Band Edges	Pass	5.7
15.207	6.6 & 7.4	Conducted Emission	Pass	5.8
15.209	6.2.2 (o)(e1)	Radiated Emission	Pass	5.9
15.203	6.2.2 (o)(e2) & 6.2.2 (o)(a3)	Antenna Requirement	Pass	5.10

5.2. Hopping Channel Separation

5.2.1. Measuring Instruments :

As described in chapter 6 of this test report.

5.2.2. Test Procedure :

1. The transmitter output was connected to the spectrum analyzer directly.
2. Set RBW of spectrum analyzer to 30kHz and VBW to 100kHz.
3. The Hopping Channel Separation is defined as the channel is separated with the next channel.

5.2.3. Test Setup Layout :

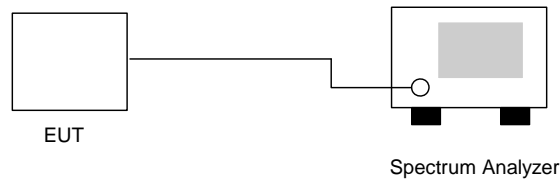

5.2.4. Test Result : The spectrum analyzer plots are attached as below

- Temperature: 24°C
- Relative Humidity: 51%
- Test Engineer : Jay

Channel	Frequency (MHz)	Hopping Channel Separation (MHz)	Limits (MHz)	Plot Ref. No.
00	2402	1.003	0.833	Mode 1
39	2441	1.003	0.861	Mode 2
78	2480	1.003	0.830	Mode 3

Remark: Limit is the greater one of 25kHz or the 20dB bandwidth of the hopping channel.



5.2.5 Hopping Channel Separation

Mode 1: CH00 (2402MHz)



*RBW 30 kHz Delta 2 [T1]
 *VBW 100 kHz 0.03 dB
 *SWT 500 ms 1.003205128 MHz

Ref 10 dBm

* Att 10 dB

1 PK
MAXH

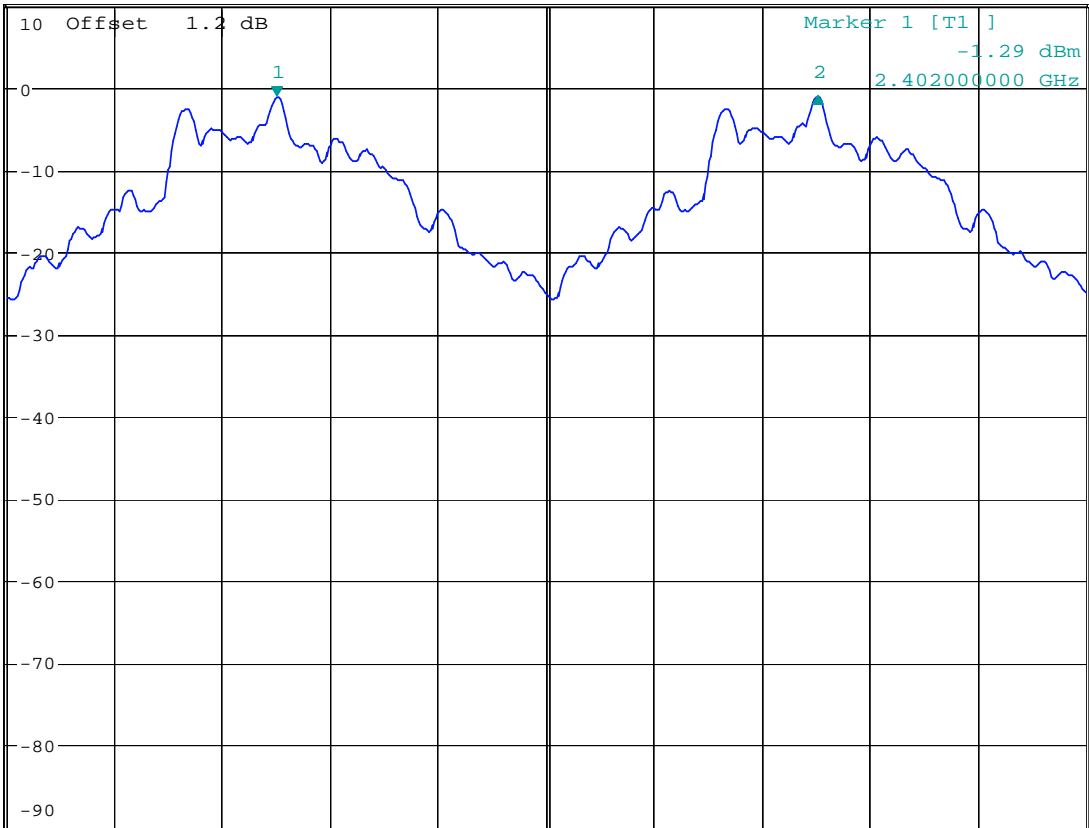

Center 2.4025 GHz 200 kHz/ Span 2 MHz

Date: 6.DEC.2005 11:16:00



Mode 2: CH39 (2441MHz)



*RBW 30 kHz Delta 2 [T1]
*VBW 100 kHz 0.01 dB
*SWT 500 ms 1.003205128 MHz

Ref 10 dBm

*Att 10 dB

1 PK
MAXH

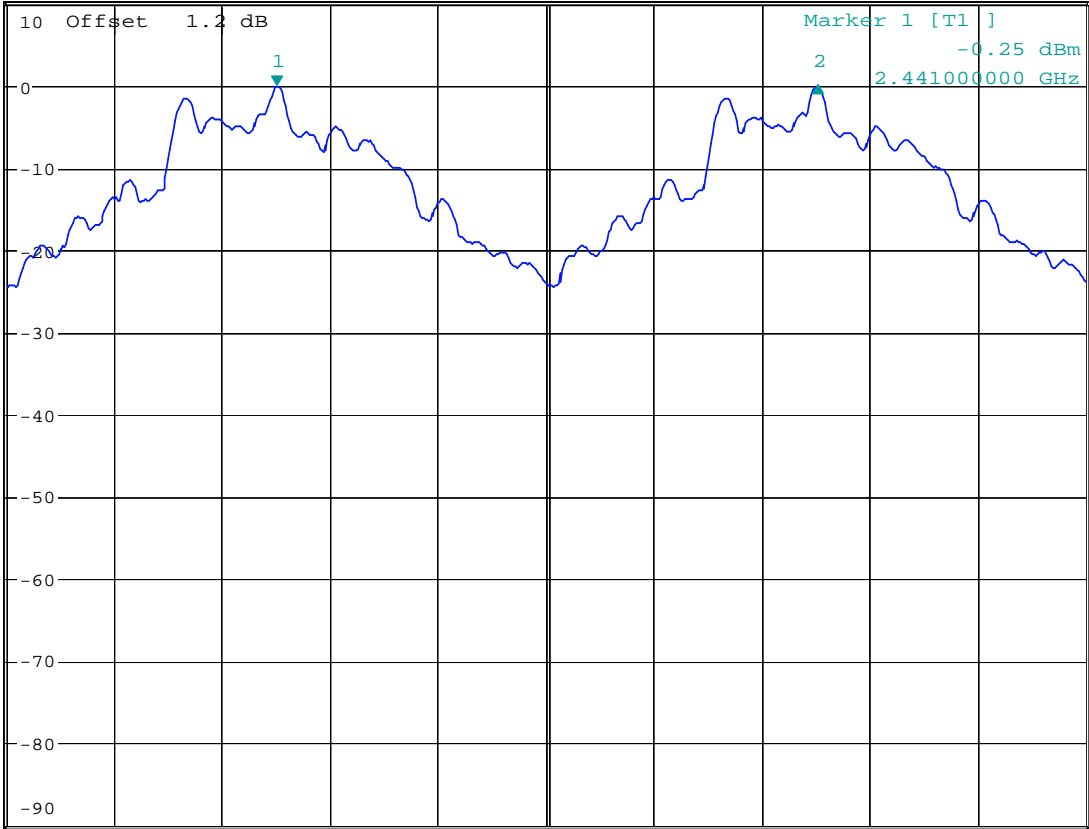

Center 2.4415 GHz

200 kHz/

Span 2 MHz

Date: 6.DEC.2005 11:15:02



Mode 3: CH78 (2480MHz)



*RBW 30 kHz Delta 2 [T1]
 *VBW 100 kHz -0.03 dB
 *SWT 500 ms 1.003205128 MHz

Ref 10 dBm

* Att 10 dB

1 PK
MAXH

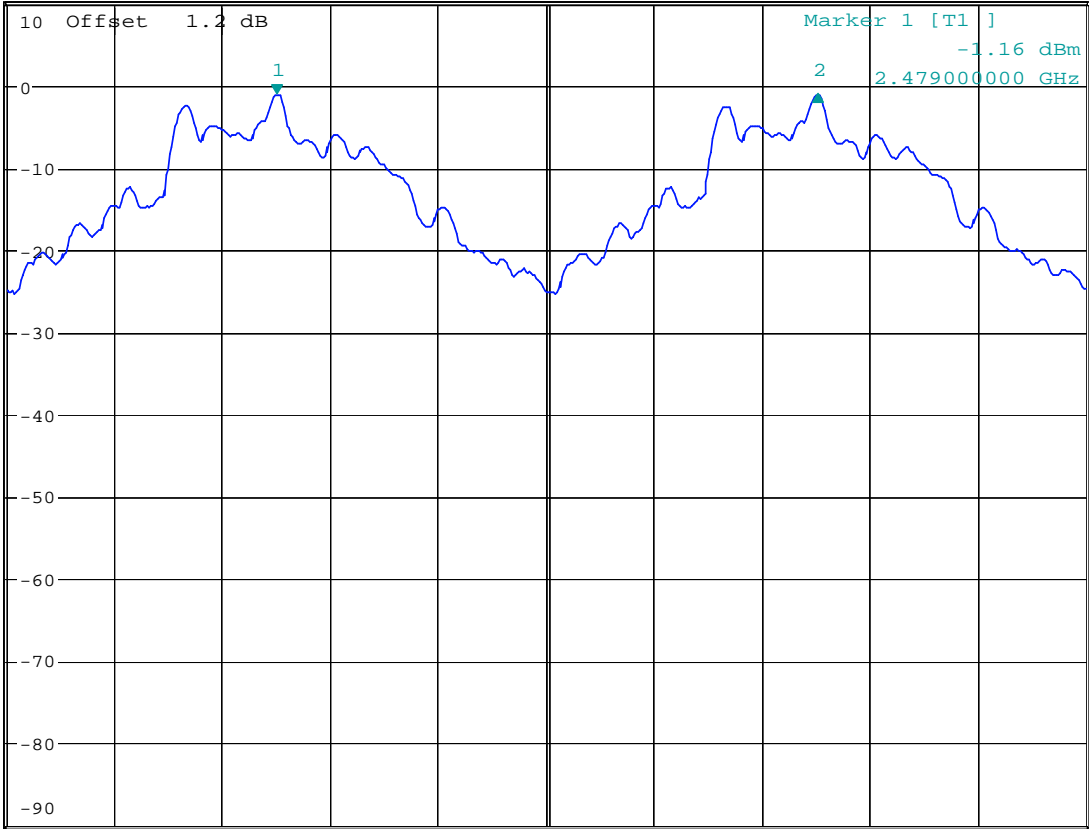

Center 2.4795 GHz

200 kHz/

Span 2 MHz

Date: 6.DEC.2005 11:28:22

5.3. Number of Hopping Frequency

5.3.1. Measuring Instruments :

As described in chapter 6 of this test report.

5.3.2. Test Procedure :

1. The transmitter output was connected to the spectrum analyzer directly.
2. Set RBW of spectrum analyzer to 100kHz and VBW to 100kHz.
3. The number of hopping frequency used is defined as the device has the numbers of total channel.

5.3.3. Test Setup Layout :

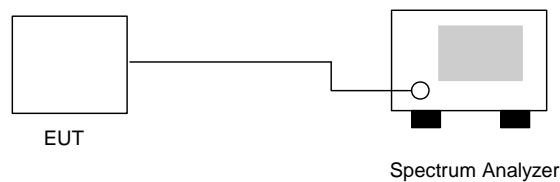

5.3.4. Test Result : See spectrum analyzer plots below

- Temperature: 24°C
- Relative Humidity: 51%
- Test Engineer : Jay

Number of Hopping Frequency (Channel)	Limits (Channel)
79	15



5.3.5 Number of Hopping Frequency

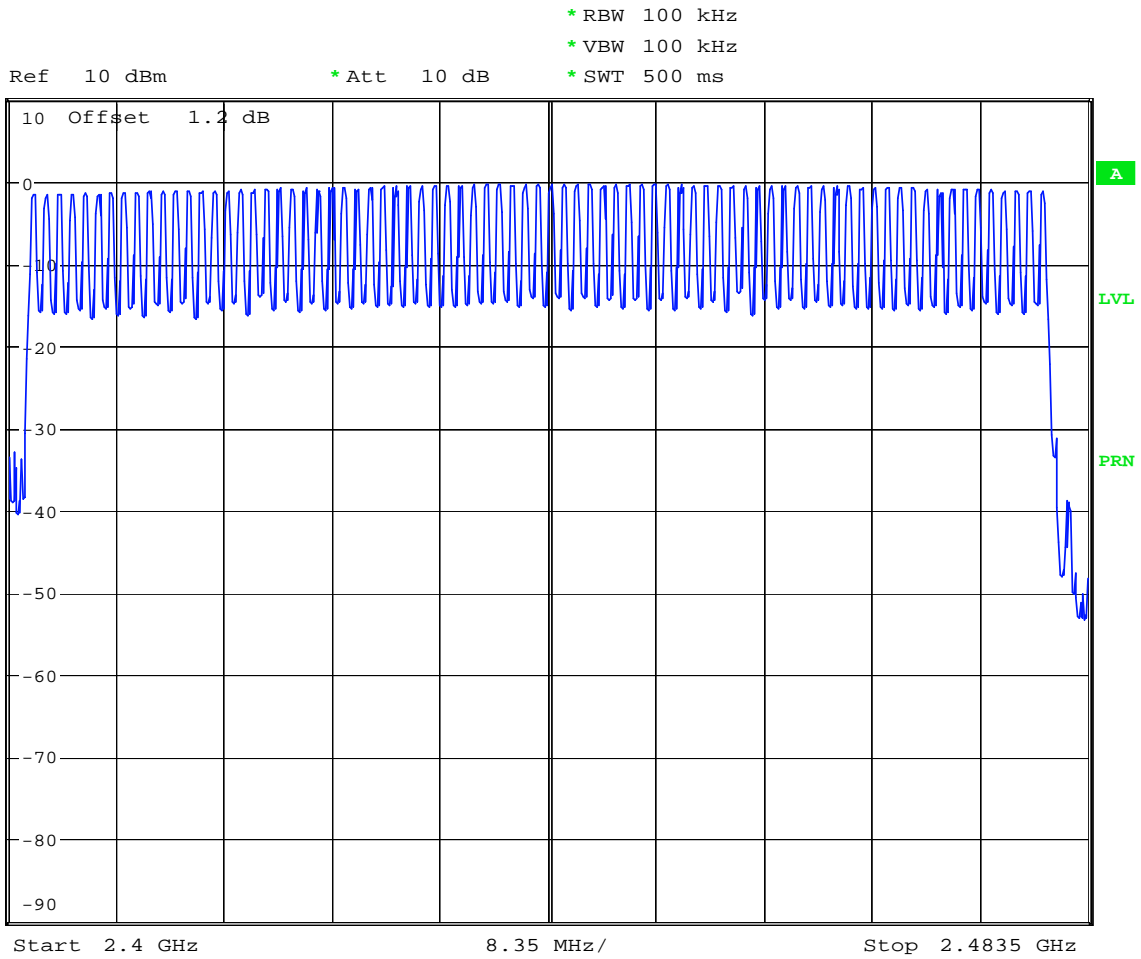

Date: 7.DEC.2005 14:45:52

5.4 Hopping Channel Bandwidth

5.4.1 Measuring Instruments :

As described in chapter 6 of this test report.

5.4.2 Test Procedure :

1. The transmitter output was connected to the spectrum analyzer directly.
2. Set RBW of spectrum analyzer to 30kHz and VBW to 300kHz.
3. The Hopping Channel bandwidth is defined as the frequency range where the power is higher than peak power minus 20dB.

5.4.3 Test Setup Layout :

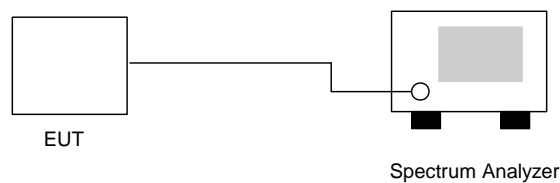

5.4.4 Test Result : See spectrum analyzer plots below

- Temperature: 24°C
- Relative Humidity: 51%
- Test Engineer : Jay

Channel	Frequency (MHz)	Hopping Channel Bandwidth (MHz)	Limits (MHz)	Plot Ref. No.
00	2402	0.833	1.0	Mode 1
39	2441	0.861	1.0	Mode 2
78	2480	0.830	1.0	Mode 3



5.4.5 Hopping Channel Bandwidth

Mode 1: CH00 (2402MHz)

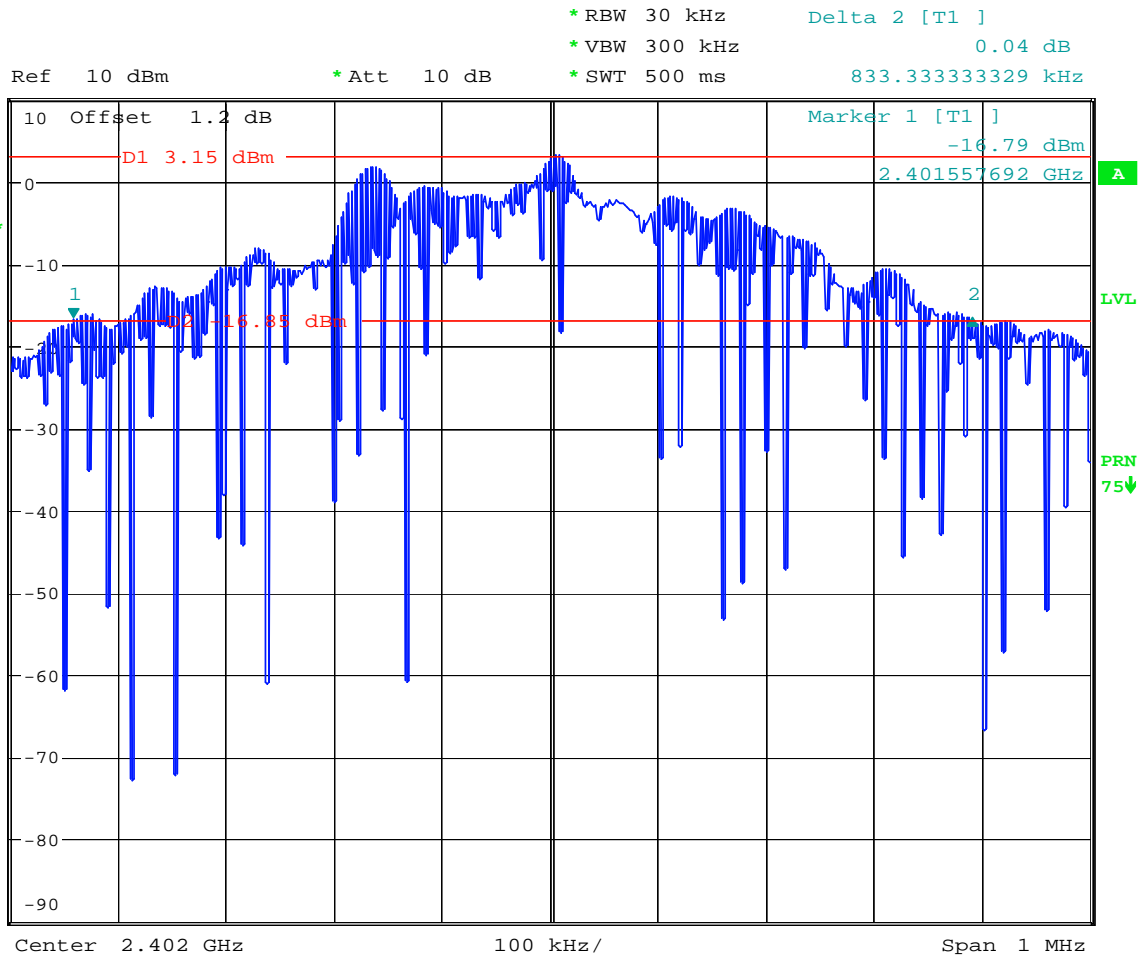

Date: 14.DEC.2005 10:36:55



Mode 2: CH39 (2441MHz)



*RBW 30 kHz Delta 2 [T1]
 *VBW 300 kHz -0.52 dB
 *SWT 500 ms 860.576923075 kHz

Ref 10 dBm

* Att 10 dB

1 PK*
VIEW

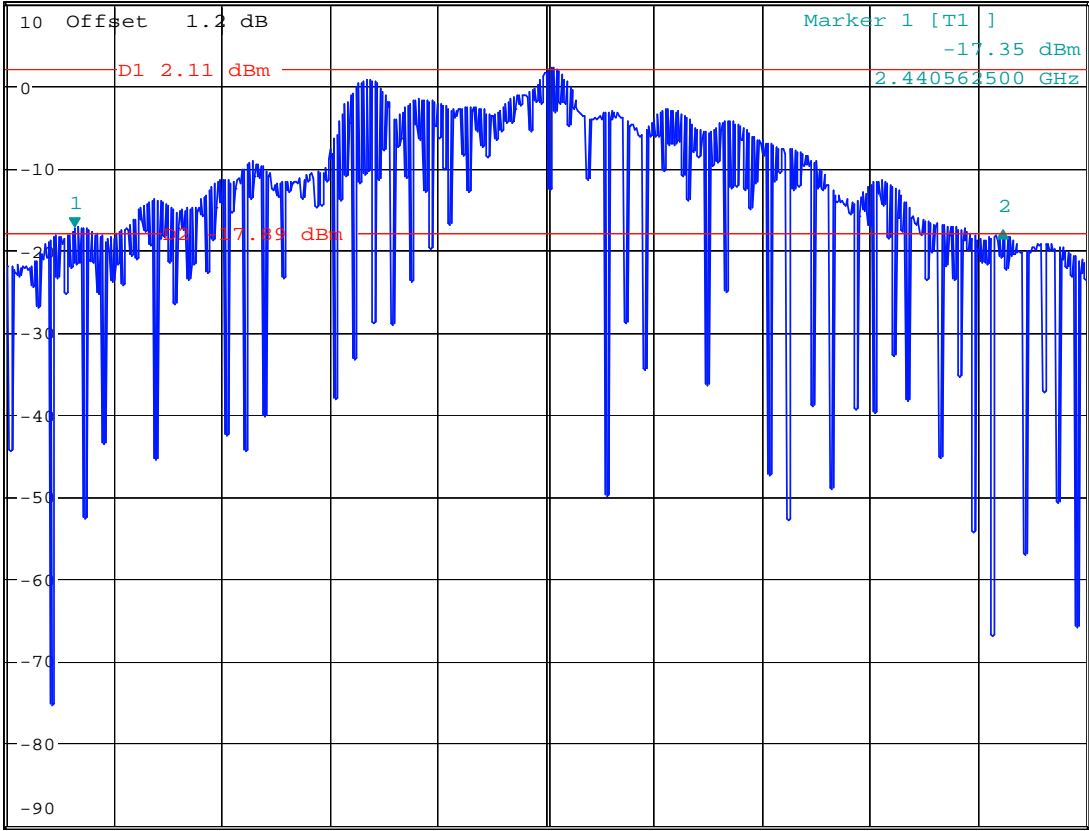

Center 2.441 GHz 100 kHz/ Span 1 MHz

Date: 14.DEC.2005 10:26:34



Mode 3: CH78 (2480MHz)



*RBW 30 kHz Delta 2 [T1]
 *VBW 300 kHz 0.25 dB
 *SWT 500 ms 830.128205128 kHz

Ref 10 dBm

* Att 10 dB

1 PK *
VIEW

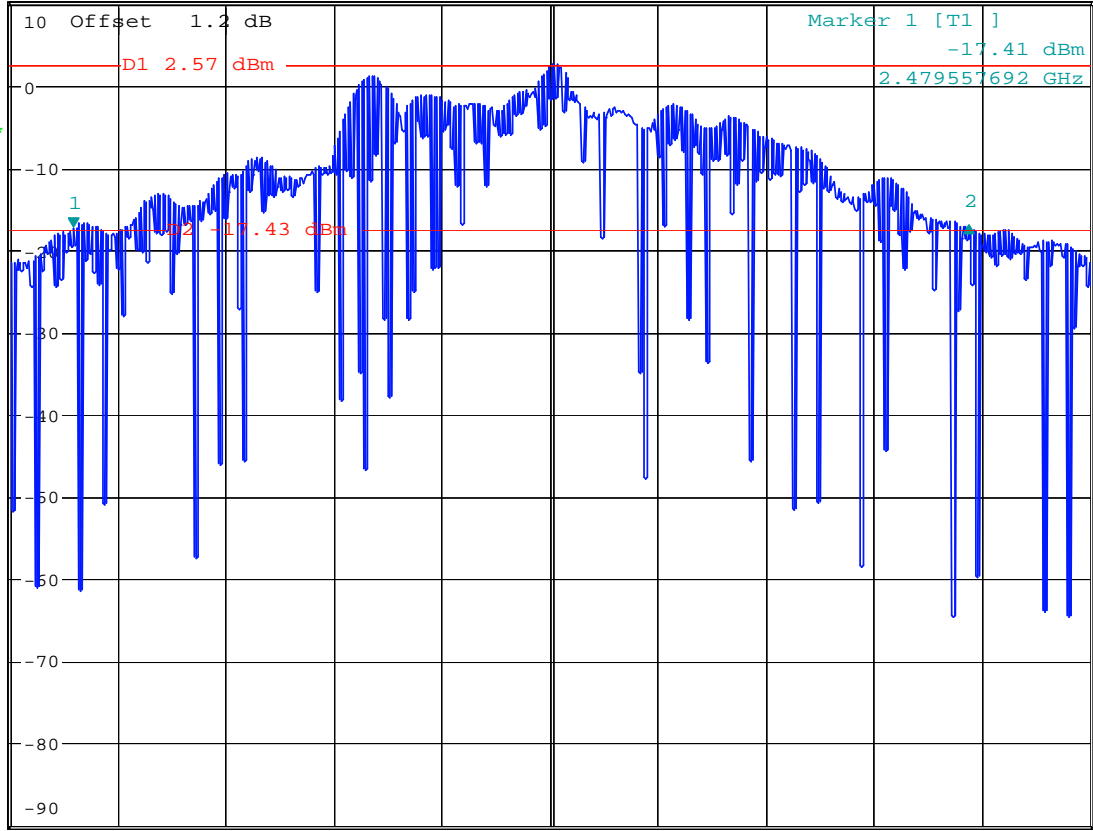

Center 2.48 GHz

100 kHz/

Span 1 MHz

Date: 14.DEC.2005 10:33:27

5.5 Dwell Time of Each Frequency within a 30 Seconds Period

5.5.1 Measuring Instruments :

As described in chapter 6 of this test report.

5.5.2 Test Procedure :

1. The transmitter output was connected to the spectrum analyzer directly.
2. Set RBW of spectrum analyzer to 1MHz and VBW to 1MHz.
3. Set the center frequency on any frequency would be measured and set the frequency span to zero span.
4. The equation = $30 \cdot (1600/79) \cdot t$ (t = the time duration of one single pulse)

5.5.3 Test Setup Layout :

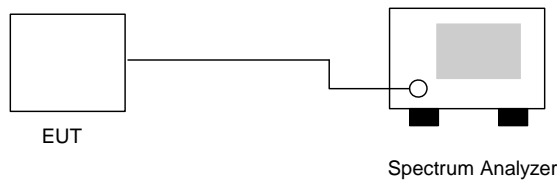

5.5.4 Test Result : See spectrum analyzer plots below

- Temperature: 24°C
- Relative Humidity: 51%
- Test Engineer : Jay

Ch00

Package Mode	Average Hopping Channel	Package Transfer Time (us)	Dwell Time (s)	Limit (s)
DH1	10.1	541.66	0.173	0.4
DH3	5	1807.69	0.286	0.4
DH5	3.4	3057.69	0.329	0.4

**CH39**

Package Mode	Average Hopping Channel	Package Transfer Time (us)	Dwell Time (s)	Limit (s)
DH1	10.2	544.87	0.176	0.4
DH3	5.1	1814.1	0.292	0.4
DH5	3.4	3072.11	0.330	0.4

CH78

Package Mode	Average Hopping Channel	Package Transfer Time (us)	Dwell Time (s)	Limit (s)
DH1	10.2	548.07	0.177	0.4
DH3	5.1	1806.09	0.291	0.4
DH5	3.4	3072.11	0.330	0.4

※ Remark:

3. Dwell Time=79(channels) x 0.4(s) x average hopping channel x package transfer time
4. 79channels come from the Hopping Channel number.
5. Average Hopping Channel = hops/sweep time
6. t: Package Transfer Time(us)



5.5.5 Dwell Time

DH1 (CH00)



Ref 10 dBm * Att 10 dB RBW 1 MHz Delta 3 [T1] -0.01 dB
 * VBW 1 MHz SWT 2 ms 1.256410 ms

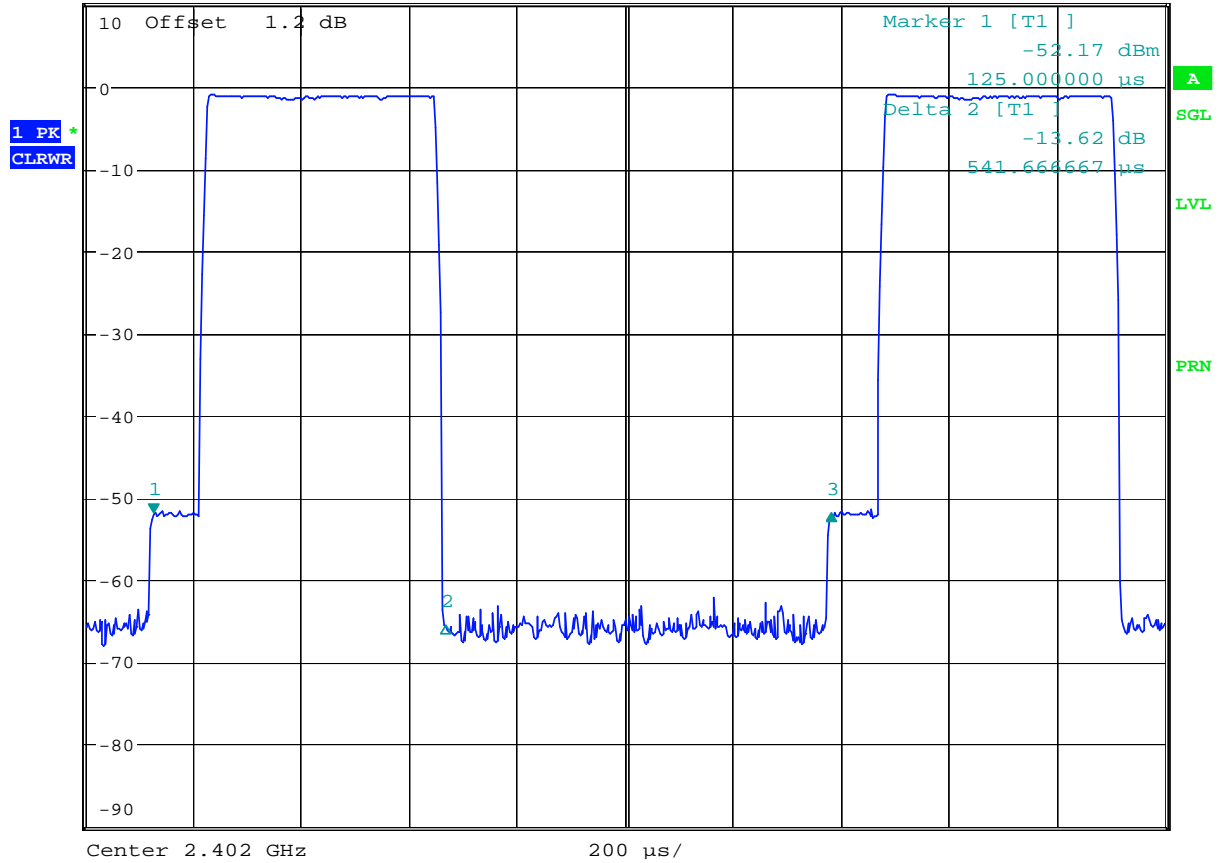

Date: 6.DEC.2005 11:48:50



Ref 10 dBm * Att 10 dB RBW 1 MHz
 * VBW 1 MHz SWT 10 s

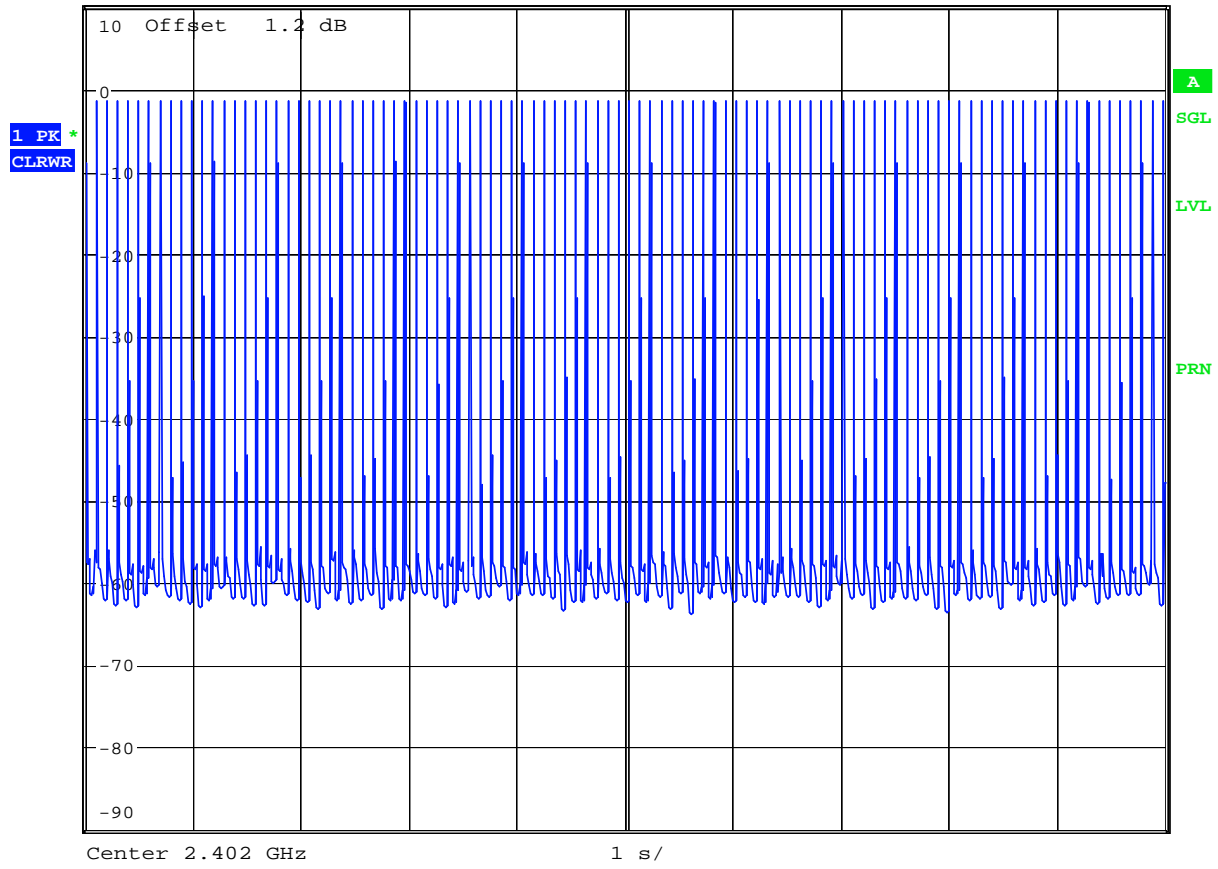

Date: 7.DEC.2005 14:20:34



DH1 (CH39)



Ref 10 dBm * Att 10 dB RBW 1 MHz Delta 3 [T1] 0.11 dB
 * VBW 1 MHz SWT 2 ms 1.256410 ms

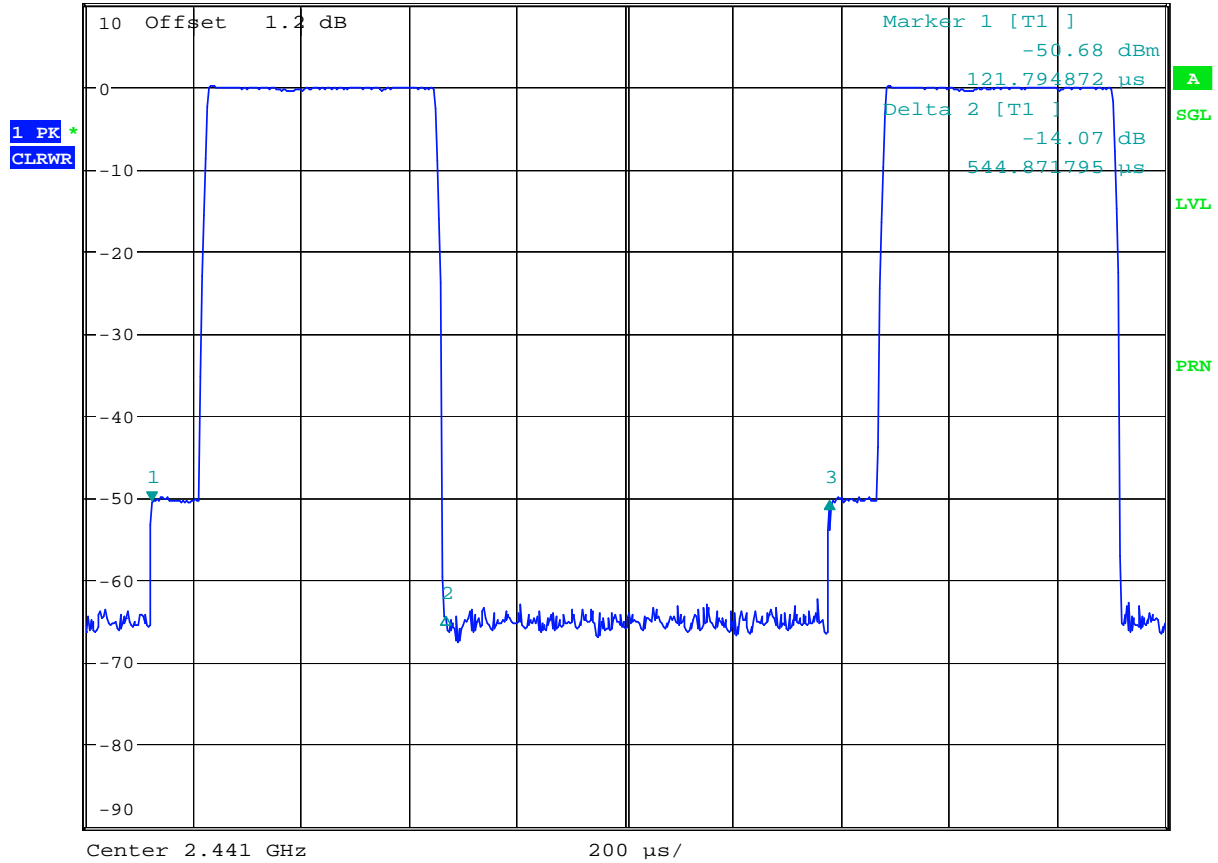

Date: 6.DEC.2005 11:42:31

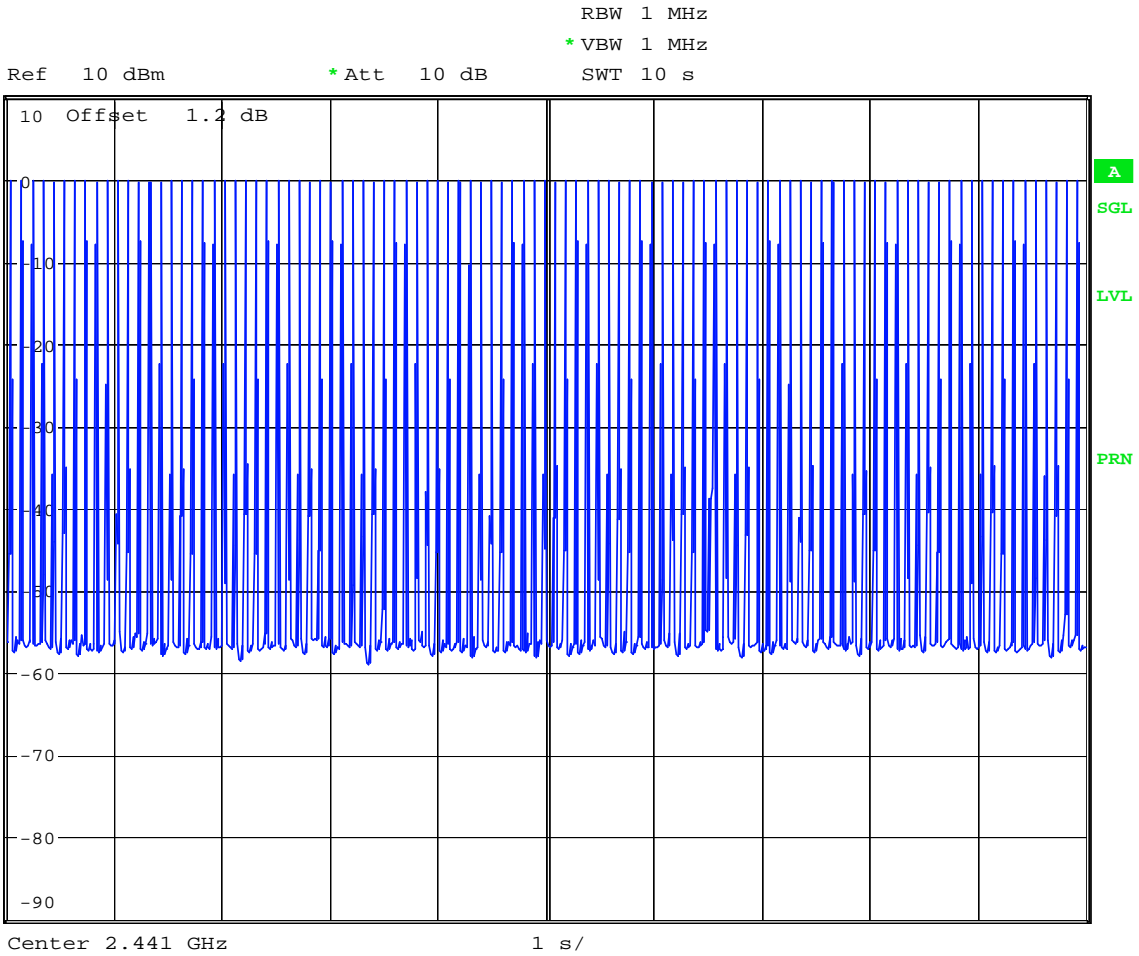

Date: 7.DEC.2005 14:21:30



DH1 (CH78)



Ref 10 dBm * Att 10 dB RBW 1 MHz Delta 3 [T1] -0.36 dB
* VBW 1 MHz SWT 2 ms 1.256410 ms

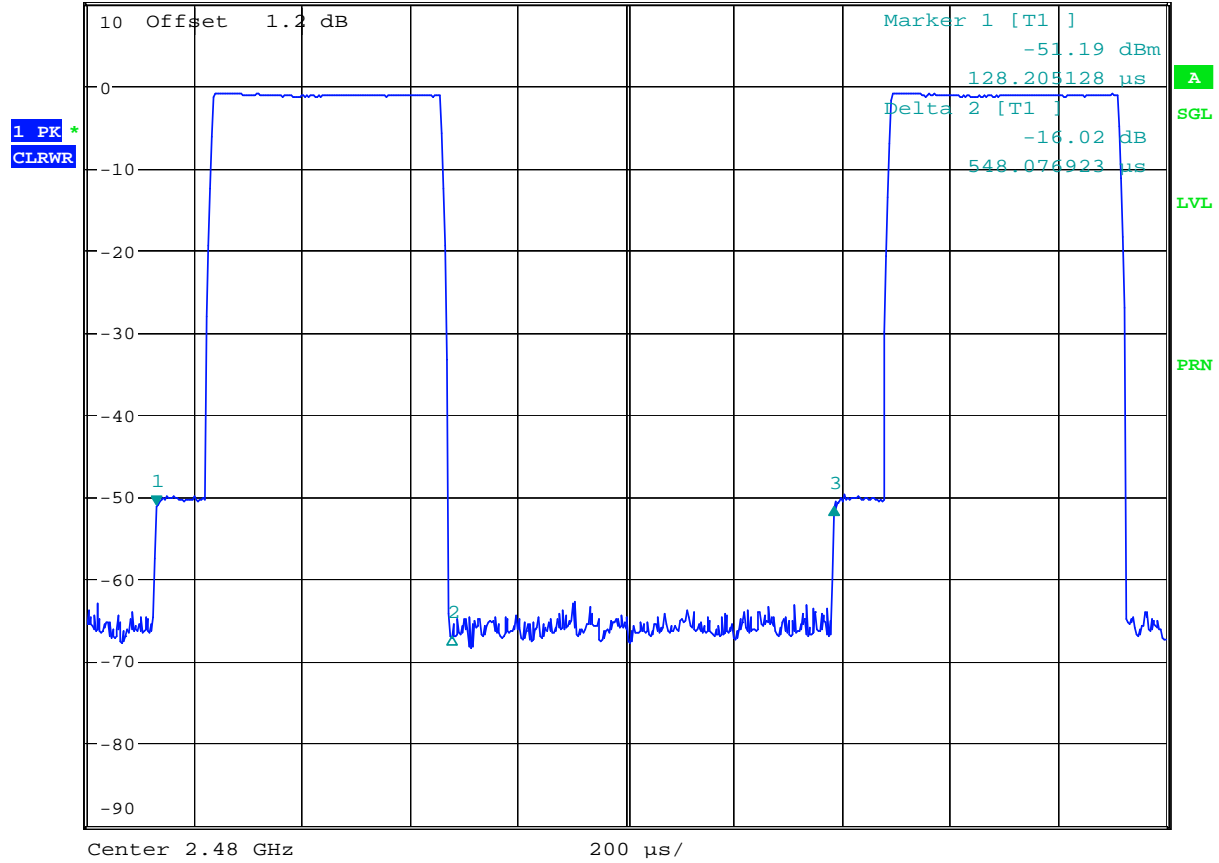

Date: 6.DEC.2005 11:35:40



Ref 10 dBm * Att 10 dB RBW 1 MHz
* VBW 1 MHz SWT 10 s

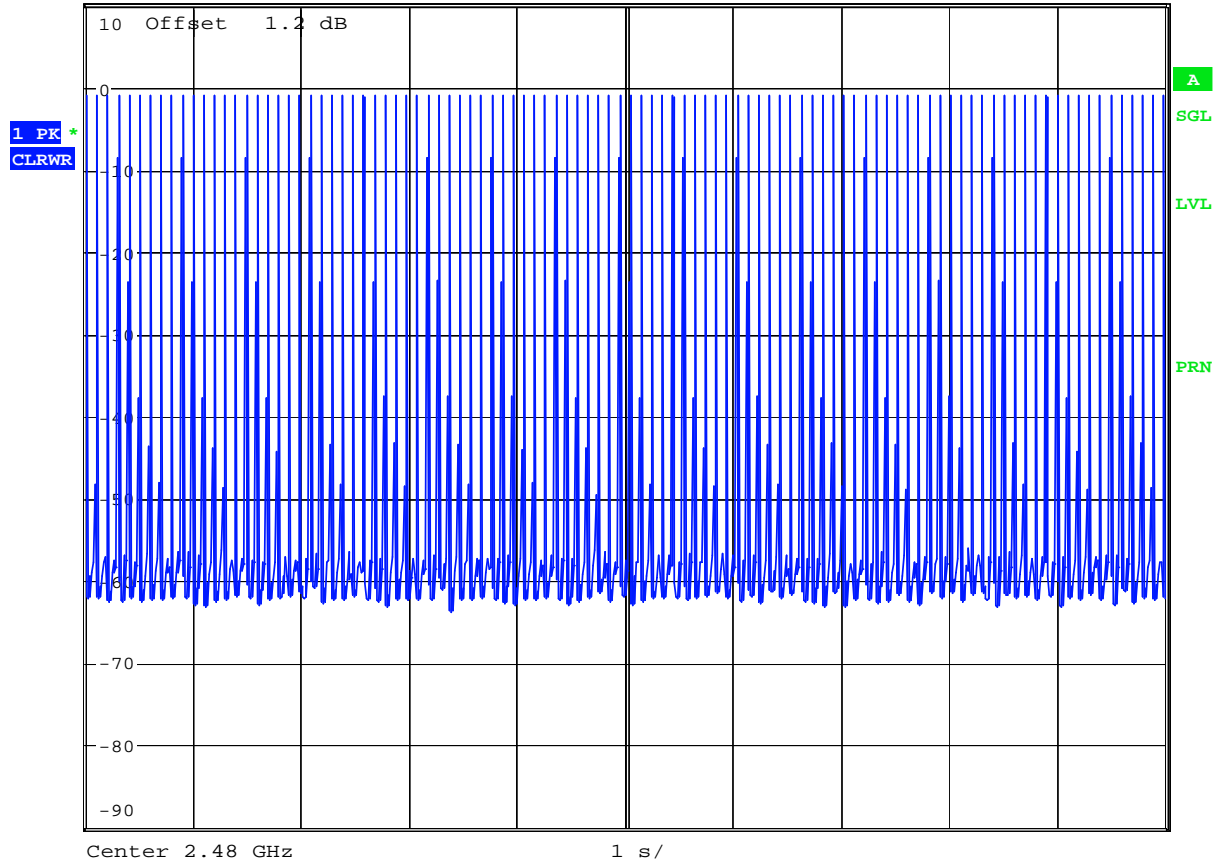

Date: 7.DEC.2005 14:21:56



DH3 (CH00)



Ref 10 dBm * Att 10 dB RBW 1 MHz Delta 3 [T1] -0.22 dB
 * VBW 1 MHz SWT 5 ms 2.514423 ms

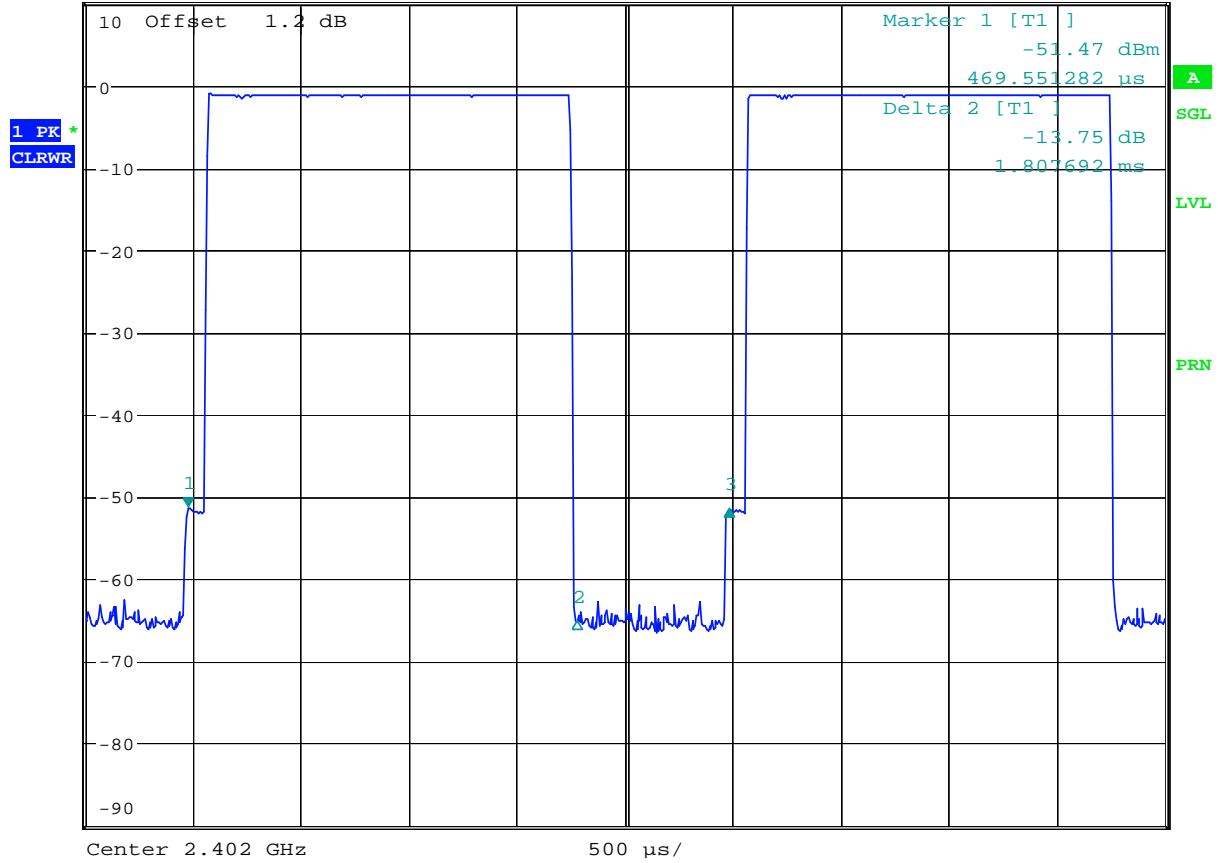

Date: 6.DEC.2005 11:50:00

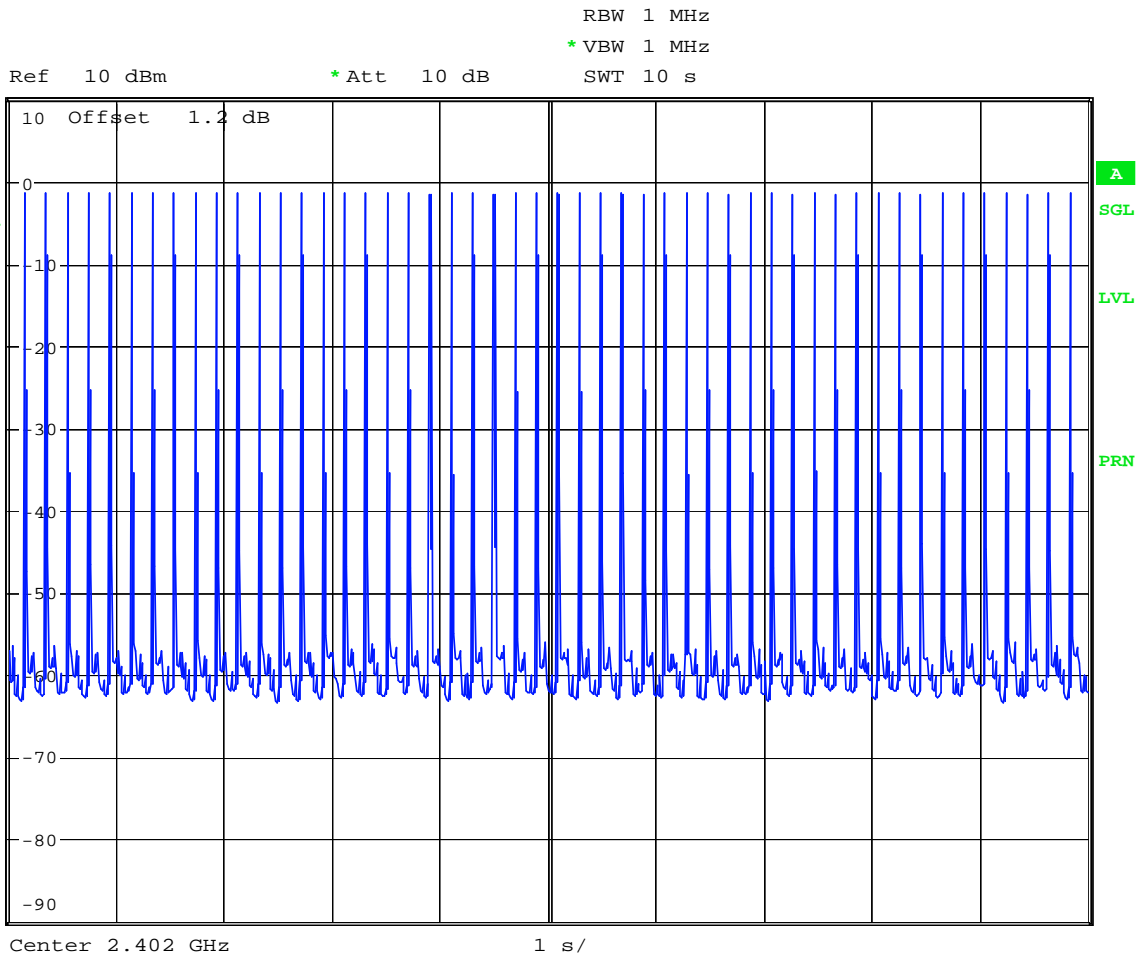

Date: 7.DEC.2005 14:23:28



DH3 (CH39)



Ref 10 dBm * Att 10 dB RBW 1 MHz Delta 3 [T1] 0.71 dB
 * VBW 1 MHz SWT 5 ms 2.514423 ms

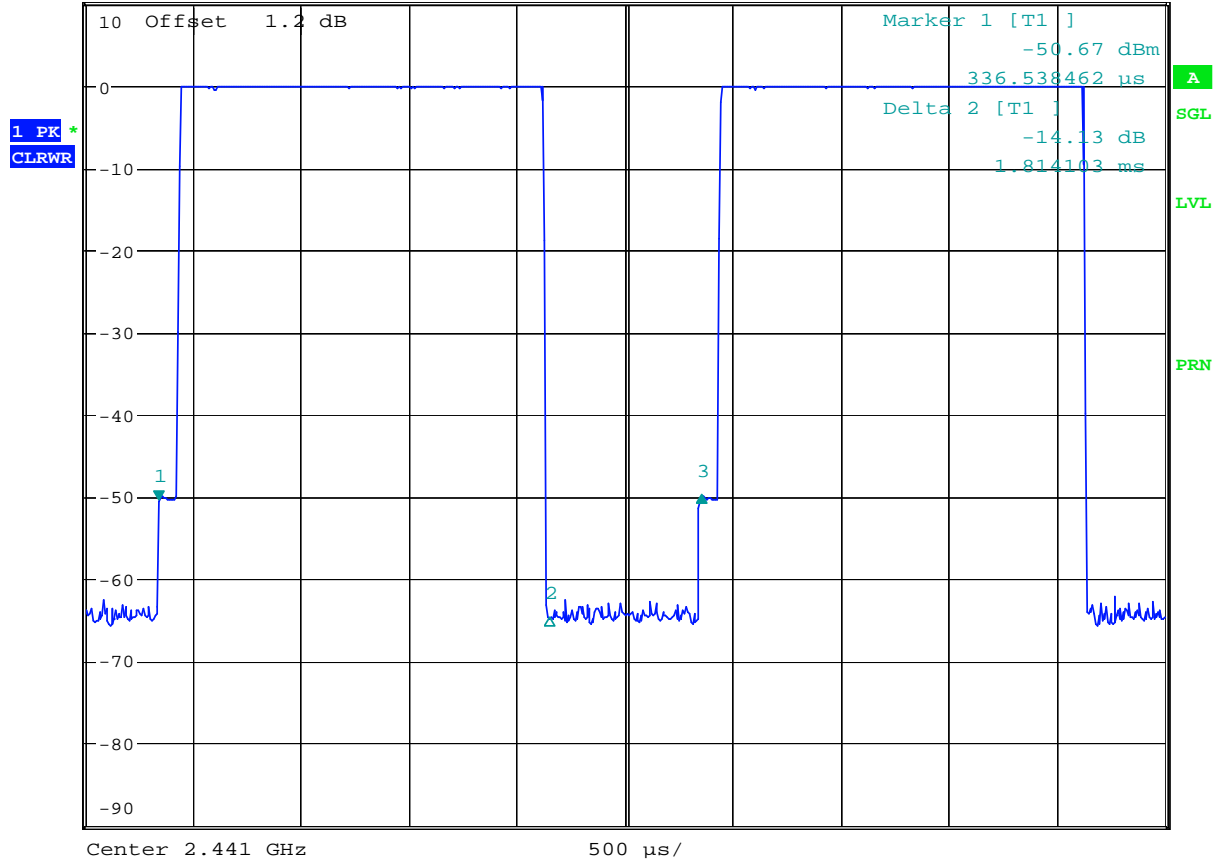

Date: 6.DEC.2005 11:41:33

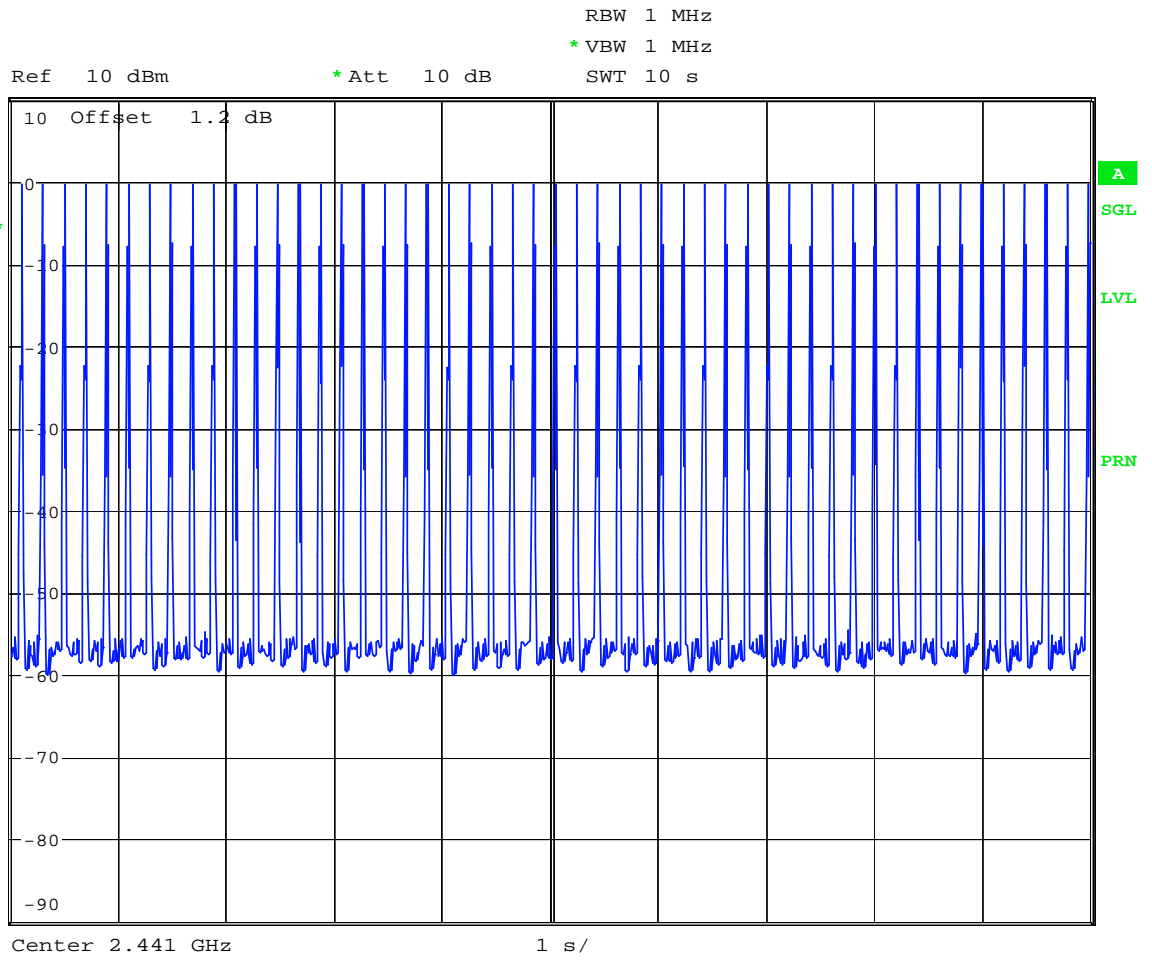

Date: 7.DEC.2005 14:23:00



DH3 (CH78)



RBW 1 MHz Delta 3 [T1] 0.20 dB
 * VBW 1 MHz SWT 5 ms 2.506410 ms
 Ref 10 dBm * Att 10 dB

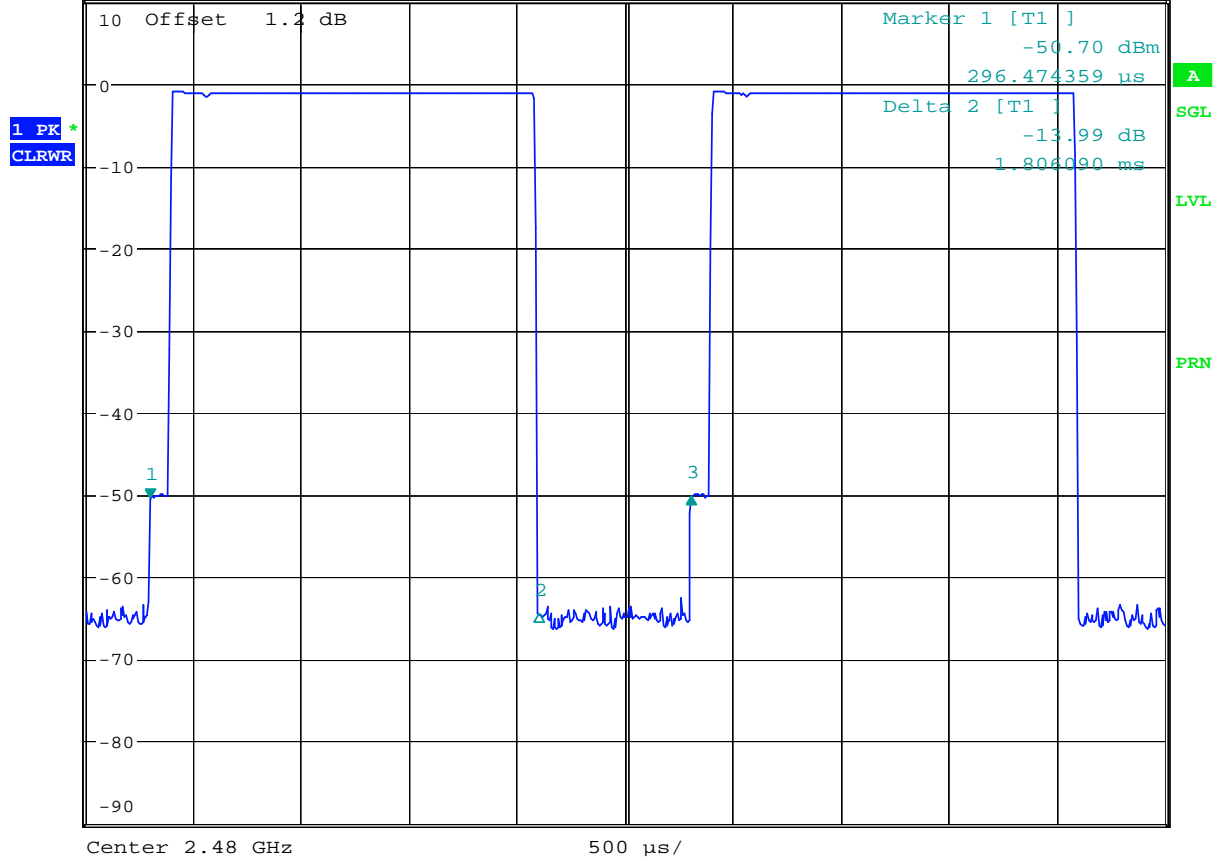

Date: 6.DEC.2005 11:36:45

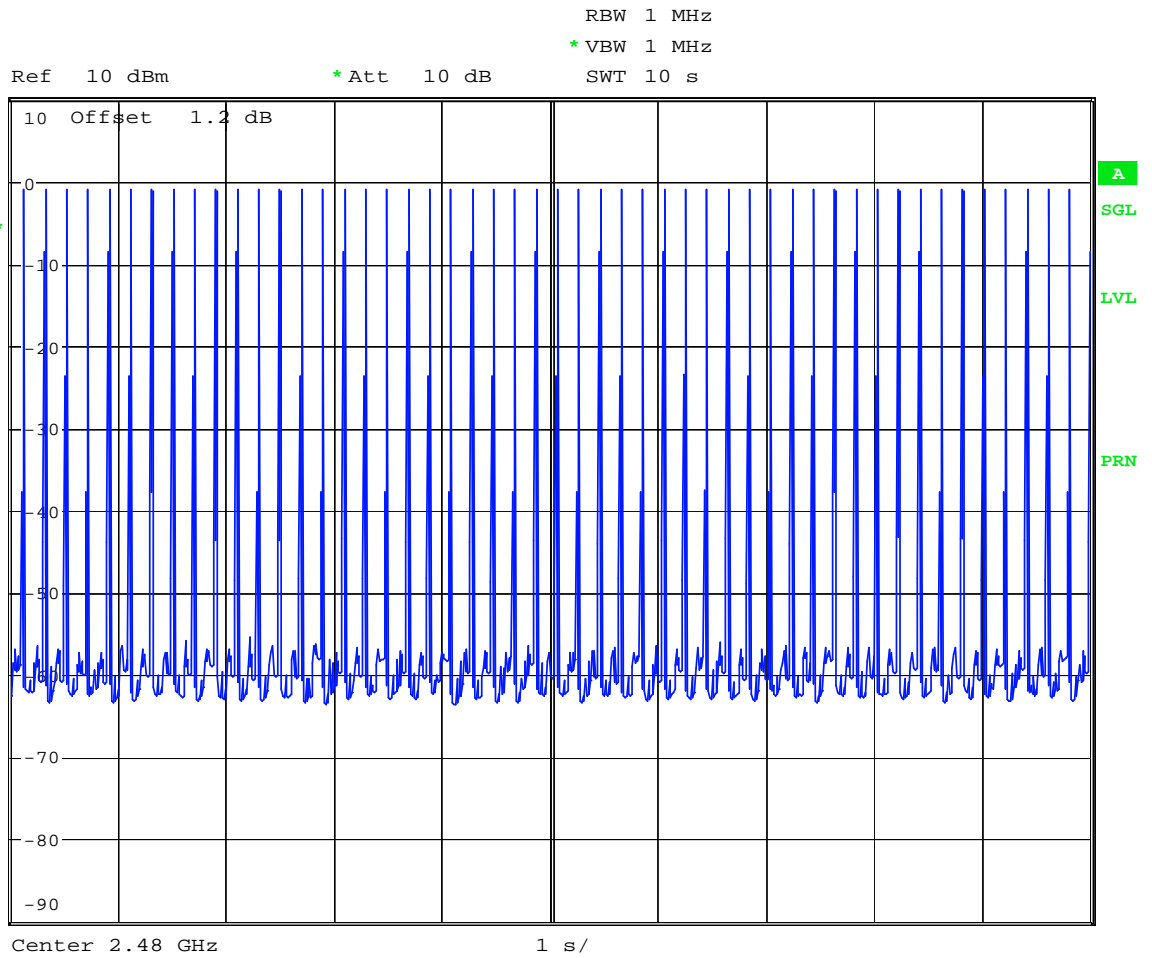

Date: 7.DEC.2005 14:22:32



DH5 (CH00)



Ref 10 dBm * Att 10 dB RBW 1 MHz Delta 3 [T1] 0.04 dB
 * VBW 1 MHz SWT 10 ms 3.764423 ms

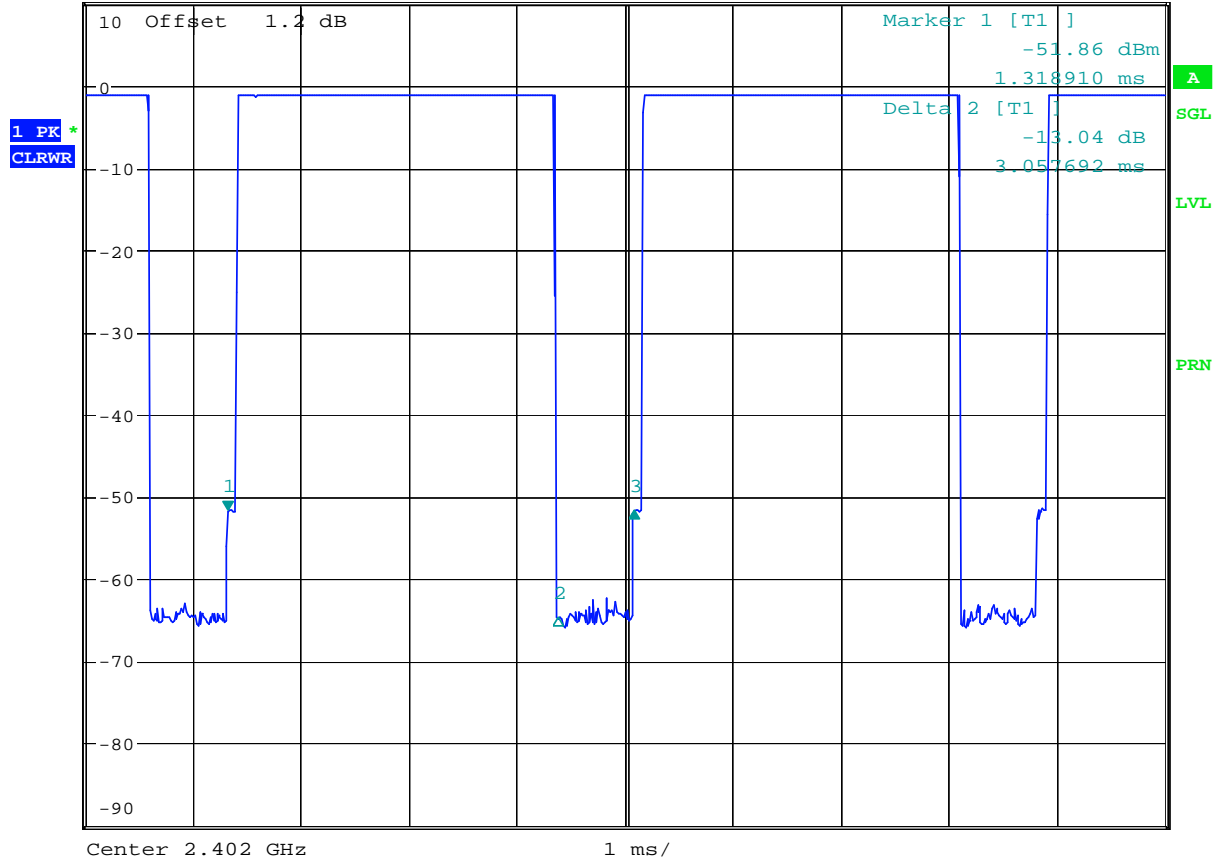

Date: 6.DEC.2005 11:50:41

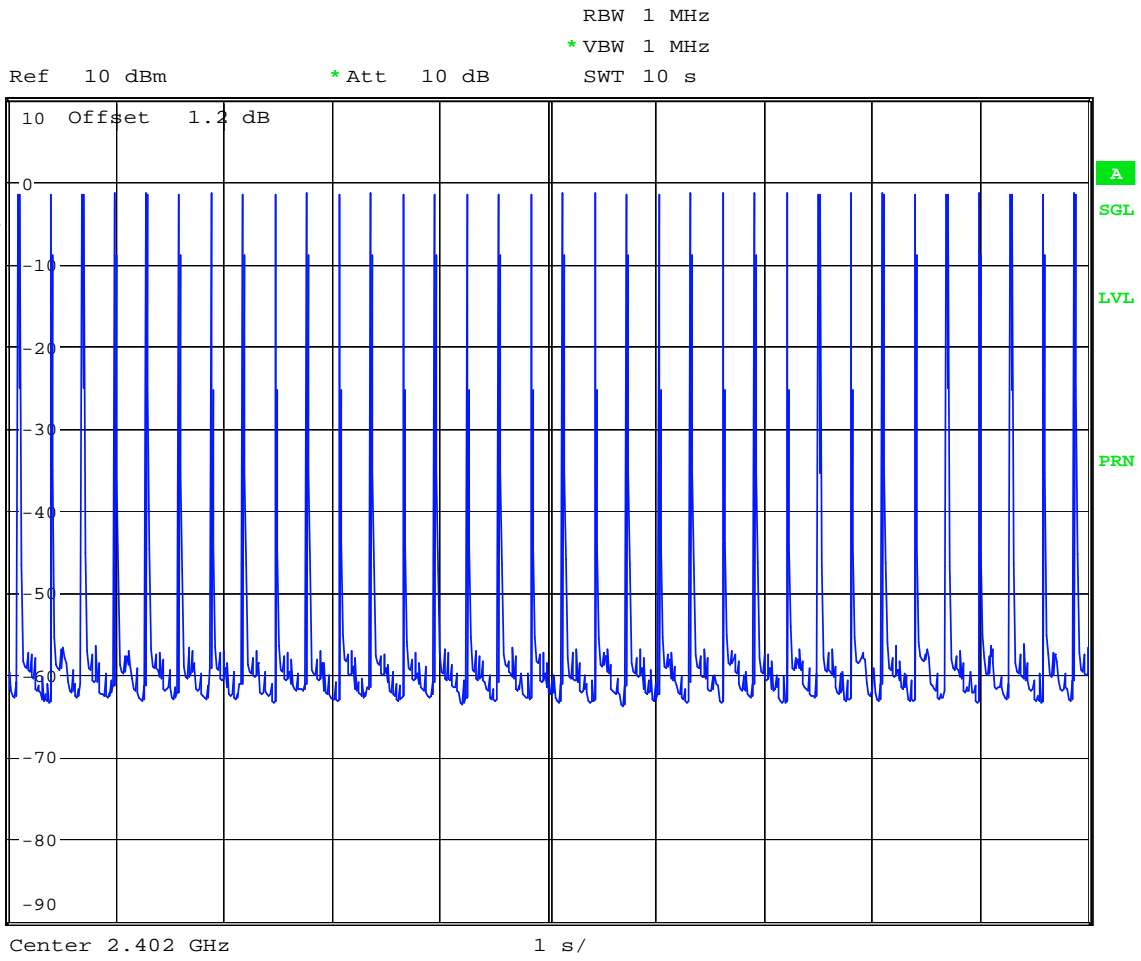

Date: 7.DEC.2005 14:23:54



DH5 (CH39)



Ref 10 dBm * Att 10 dB RBW 1 MHz Delta 3 [T1]
* VBW 1 MHz SWT 10 ms -0.26 dB
3.756410 ms

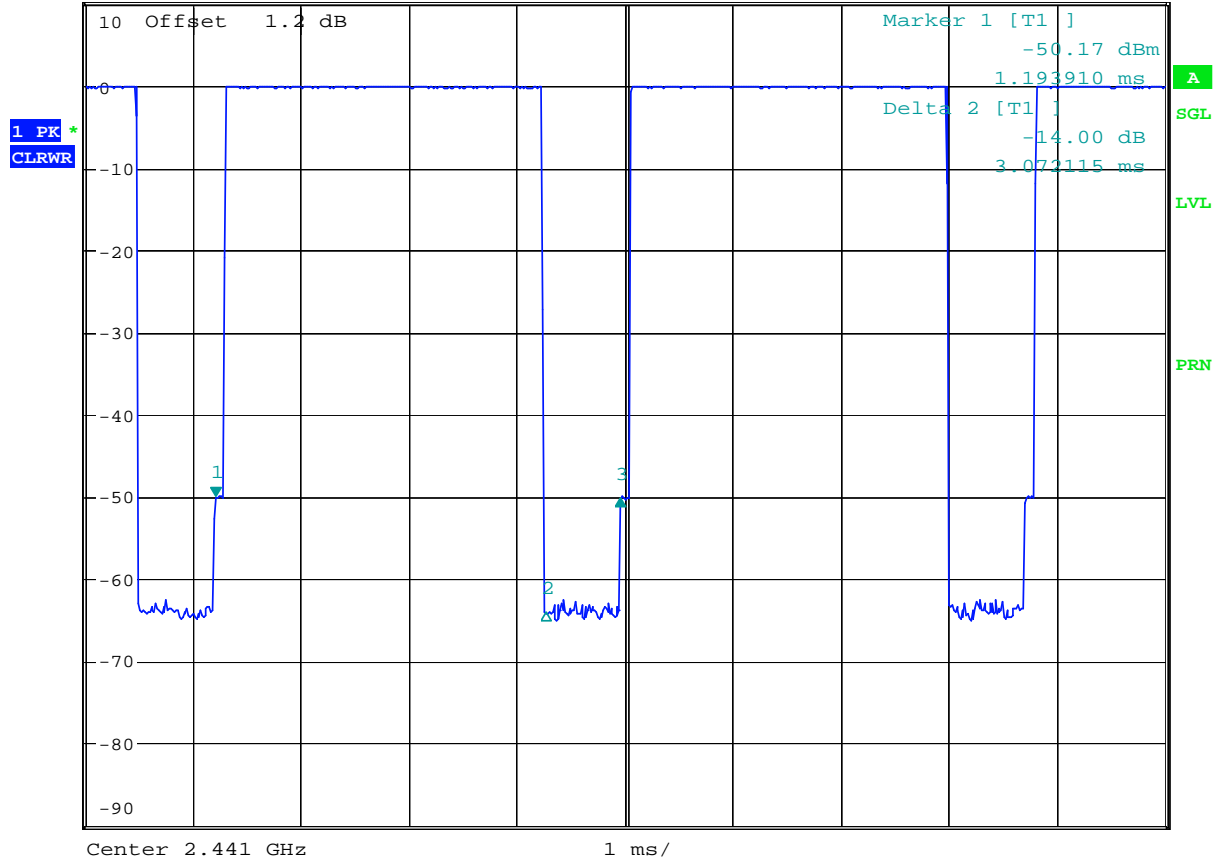

Date: 6.DEC.2005 11:39:01

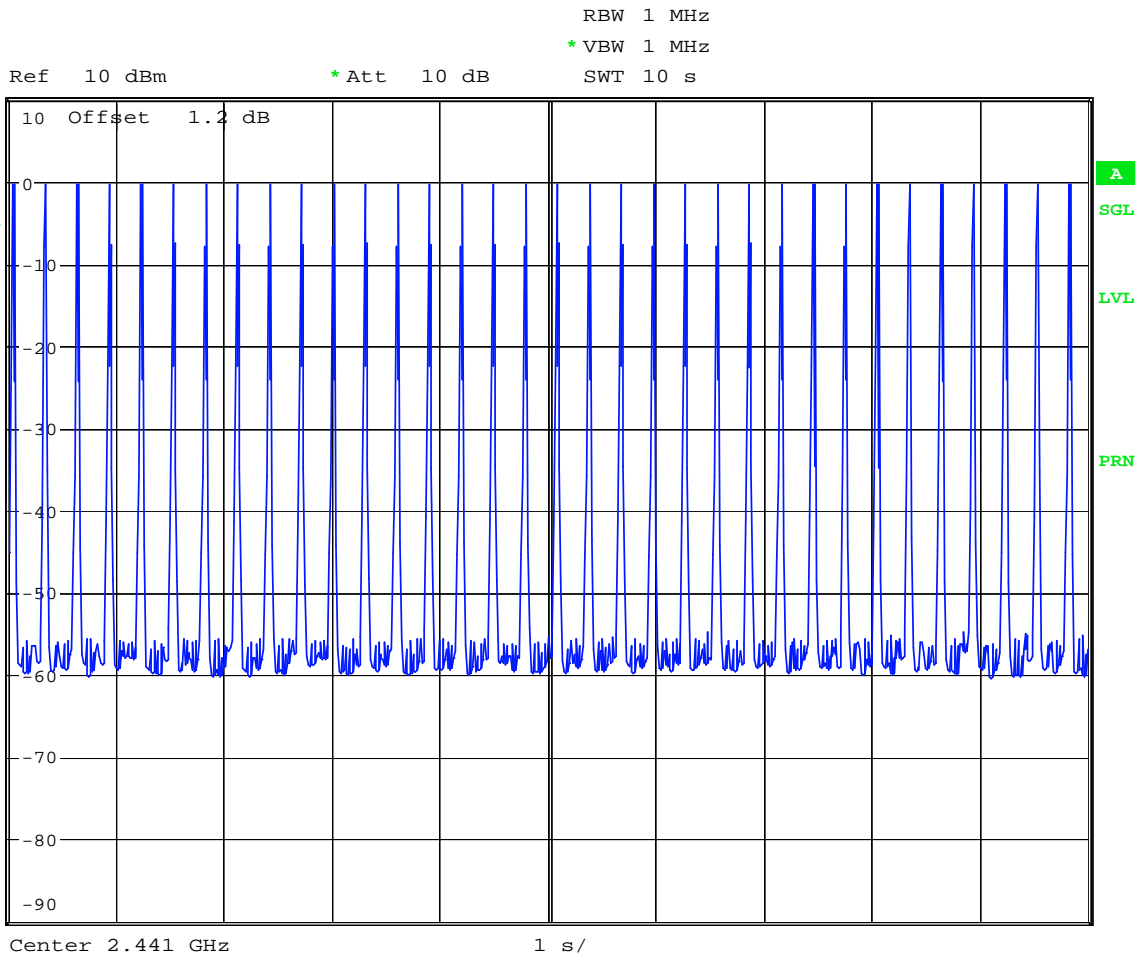

Date: 7.DEC.2005 14:24:27



DH5 (CH78)



Ref 10 dBm * Att 10 dB RBW 1 MHz Delta 3 [T1] 0.14 dB
 * VBW 1 MHz SWT 10 ms 3.772436 ms

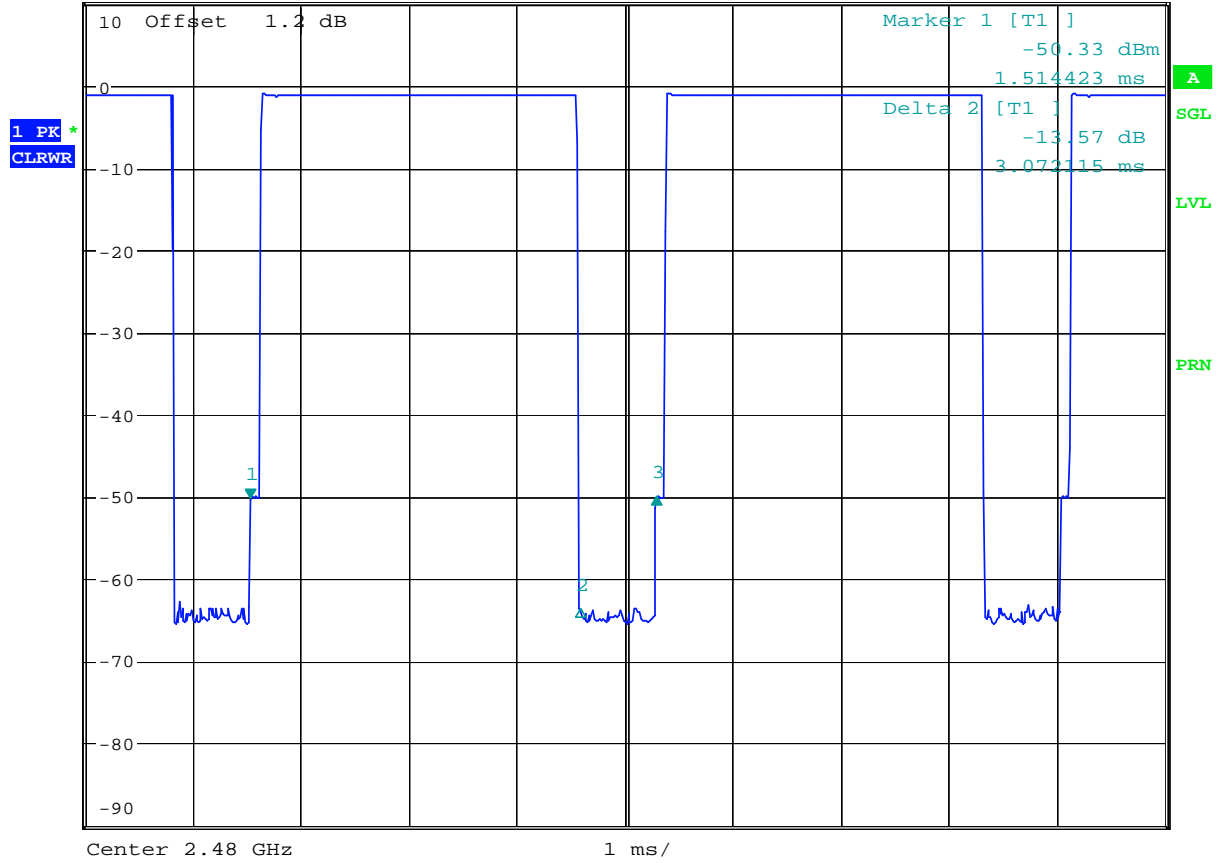

Date: 6.DEC.2005 11:37:42

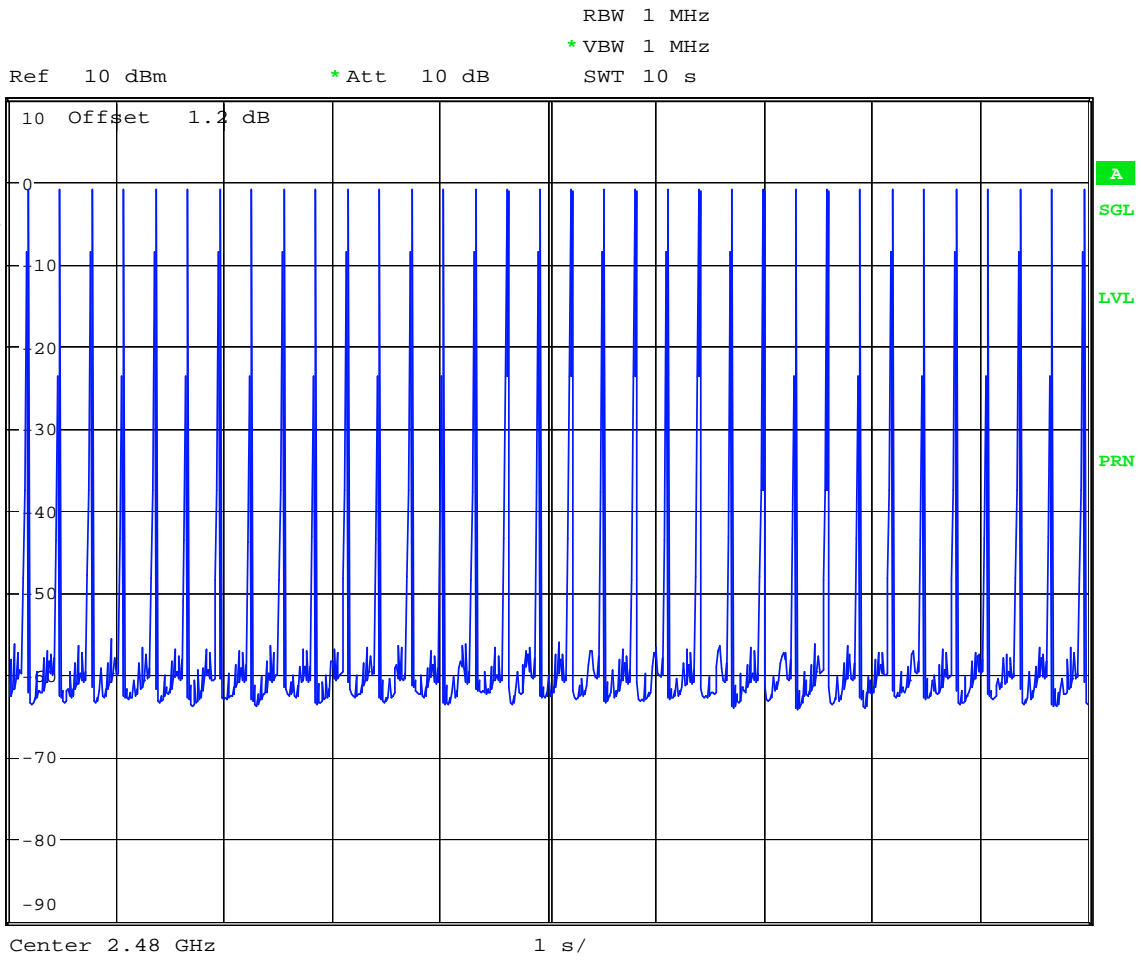

Date: 7.DEC.2005 14:24:54

5.6 Output Power

5.6.1 Measuring Instruments :

As described in chapter 6 of this test report.

5.6.2 Test Procedure :

1. The transmitter output was connected to the spectrum analyzer directly.
2. The center frequency of the spectrum analyzer was set to the fundamental frequency and set RBW to 3MHz and VBW to 3MHz.

5.6.3 Test Setup Layout :

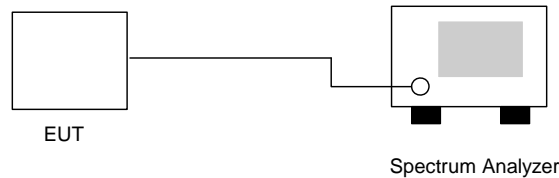

5.6.4 Test Result : See spectrum analyzer plots below

- Temperature: 24°C
- Relative Humidity: 51%
- Test Engineer : Jay

Channel	Frequency (MHz)	Measured Output Power (dBm)	Limits (Watt/dBm)	Plot Ref. No.
00	2402	3.28	1W/30 dBm	Mode 1
39	2441	2.27	1W/30 dBm	Mode 2
78	2480	2.85	1W/30 dBm	Mode 3



5.6.5 Output Power

Mode 1: CH00 (2402MHz)



* RBW 3 MHz Marker 1 [T1]
 * VBW 3 MHz 3.28 dBm
 * SWT 500 ms 2.401815705 GHz
 Ref 10 dBm * Att 10 dB

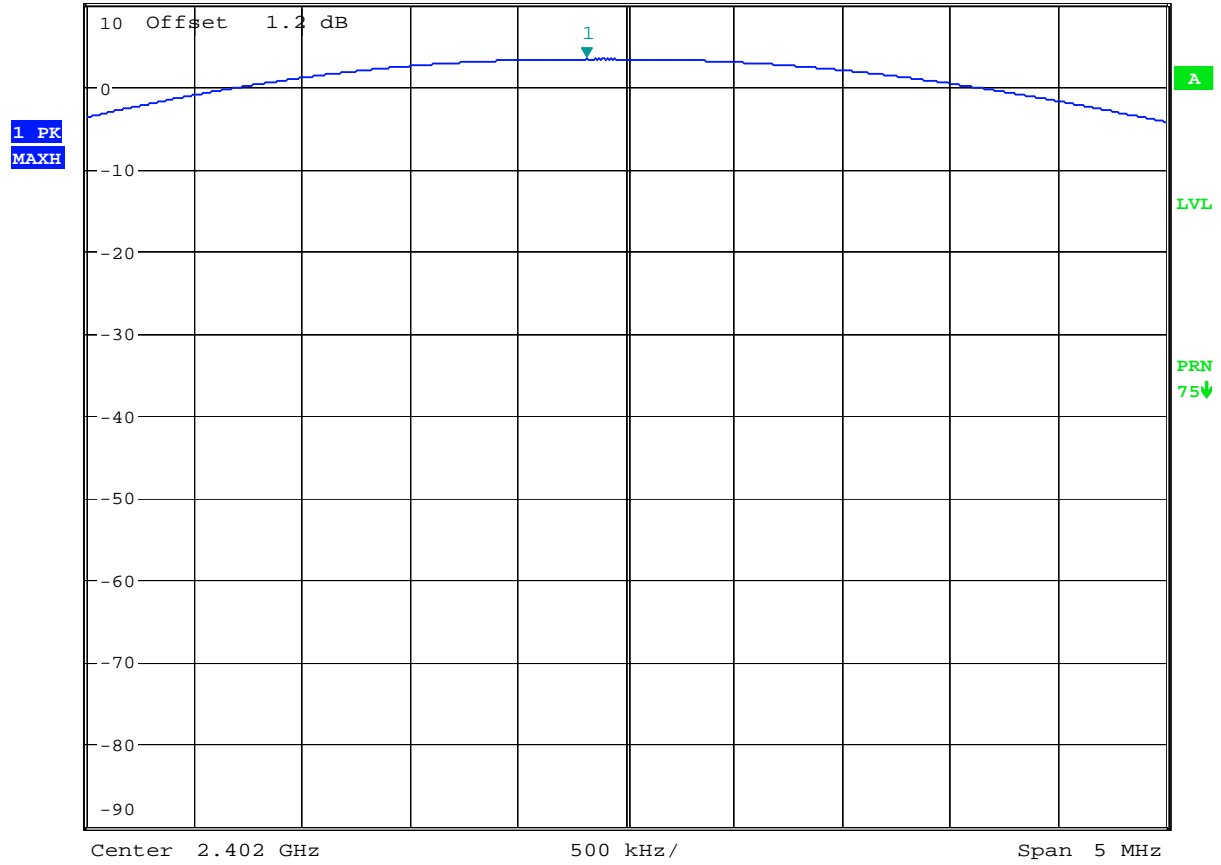

Date: 14.DEC.2005 10:40:03



Mode 2: CH39 (2441MHz)



* RBW 3 MHz
* VBW 3 MHz
* SWT 500 ms
Marker 1 [T1]
2.27 dBm
2.440871795 GHz

Ref 10 dBm

* Att 10 dB

1 PK
MAXH

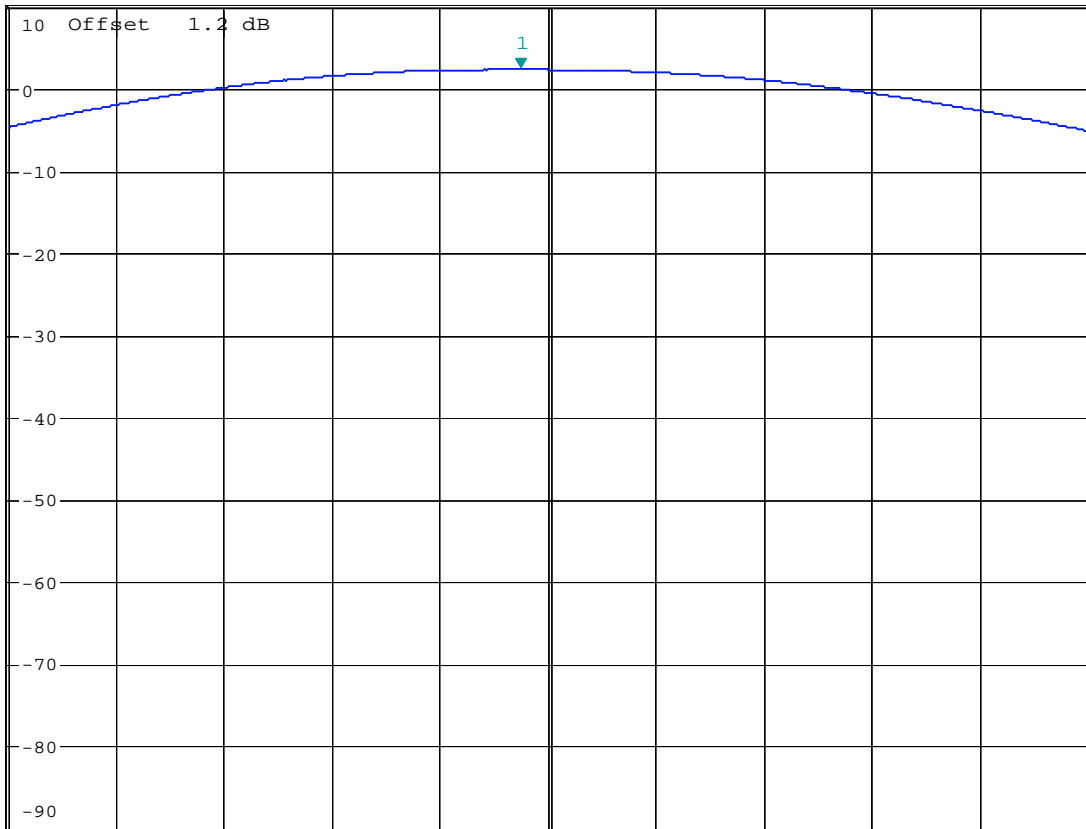

Center 2.441 GHz

500 kHz/

Span 5 MHz

Date: 14.DEC.2005 10:20:13



Mode 3: CH78 (2480MHz)



* RBW 3 MHz Marker 1 [T1]
 * VBW 3 MHz 2.85 dBm
 * SWT 500 ms 2.479783654 GHz

Ref 10 dBm

* Att 10 dB

1 PK
MAXH

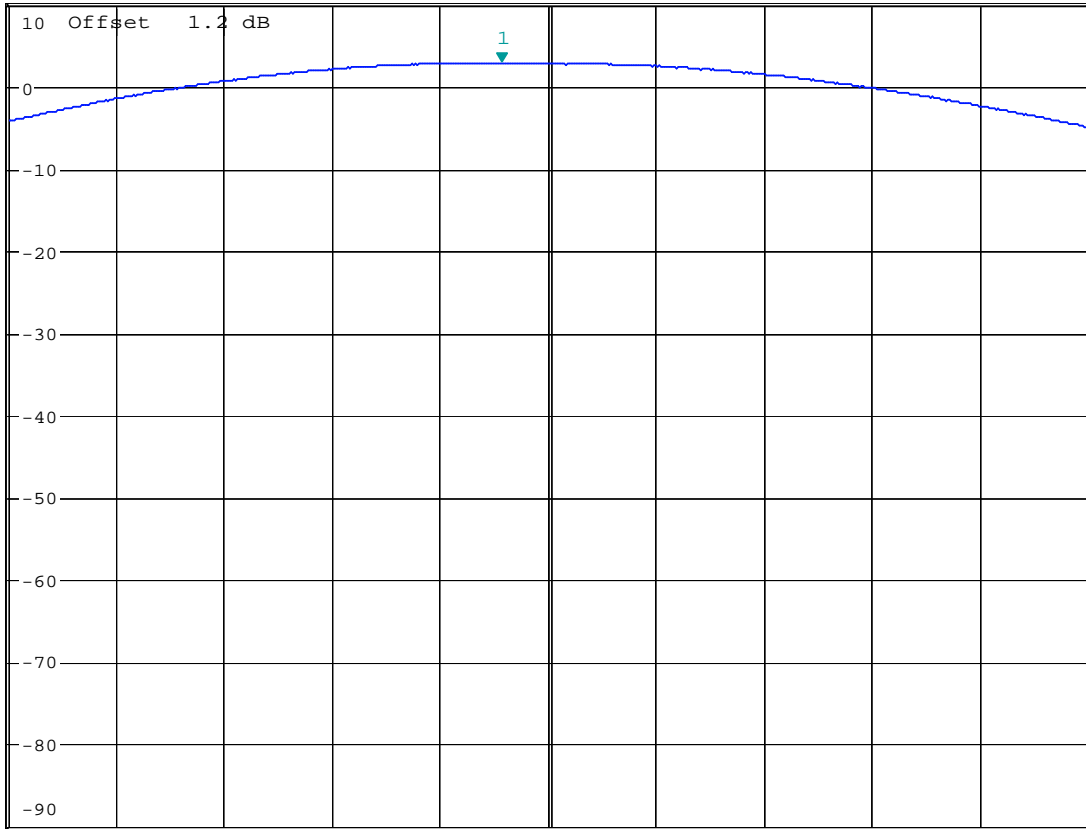

Center 2.48 GHz

500 kHz/

Span 5 MHz

Date: 14.DEC.2005 10:40:32



5.7 100kHz Bandwidth of Frequency Band Edges

5.7.1 Measuring Instruments :

As described in chapter 6 of this test report.

5.7.2 Test Procedure :

1. The transmitter output was connected to the spectrum analyzer via a low lose cable.
2. Set both RBW and VBW of spectrum analyzer to 100kHz with suitable frequency span for the conducted measurement, and RBW/VBW=1MHz/1MHz for peak measurement and RBW/VBW=1MHz/300Hz for average measurement in the radiated measurement.
3. The band edges was measured and recorded.

5.7.3 Test Result :

- Temperature: 24°C
- Relative Humidity: 51%
- Test Engineer : Jay

Test Result in lower band (Channel 00) : PASS

Test Result in higher band(Channel 78) : PASS

5.7.4 Note on Band edge Emission

CH00 (Horizontal)

Frequency (MHz)	Level (dBuV/m)	Over Limit (dB)	Limit Line (dBuV/m)	Read Level (dBuV)	Factor (dB)	Cable Loss (dB)	Preamp Factor (dB)	Ant Pos (cm)	Table Pos (deg)	Detect Mode
2390.00	50.40	-23.60	74.00	51.11	30.48	4.26	35.46	200	0	Peak
2390.00	39.65	-14.35	54.00	40.36	30.48	4.26	35.46	157	328	Average

CH00 (Vertical)

Frequency (MHz)	Level (dBuV/m)	Over Limit (dB)	Limit Line (dBuV/m)	Read Level (dBuV)	Factor (dB)	Cable Loss (dB)	Preamp Factor (dB)	Ant Pos (cm)	Table Pos (deg)	Detect Mode
2390.00	51.22	-22.78	74.00	51.93	30.48	4.26	35.46	200	0	Peak
2390.00	39.55	-14.45	54.00	40.26	30.48	4.26	35.46	100	241	Average



CH78 (Horizontal)

Frequency (MHz)	Level (dBuV/m)	Over Limit (dB)	Limit Line (dBuV/m)	Read Level (dBuV)	Factor (dB)	Cable Loss (dB)	Preamp Factor (dB)	Ant Pos (cm)	Table Pos (deg)	Detect Mode
2483.50	72.94	-1.06	74.00	73.67	30.41	4.36	35.51	200	360	Peak
2483.50	45.43	-8.57	54.00	46.17	30.41	4.36	35.51	100	60	Average

CH78 (Vertical)

Frequency (MHz)	Level (dBuV/m)	Over Limit (dB)	Limit Line (dBuV/m)	Read Level (dBuV)	Factor (dB)	Cable Loss (dB)	Preamp Factor (dB)	Ant Pos (cm)	Table Pos (deg)	Detect Mode
2483.50	70.88	-3.12	74.00	71.62	30.41	4.36	35.51	200	0	Peak
2483.50	47.17	-6.83	54.00	47.91	30.41	4.36	35.51	100	240	Average



5.7.5 Frequency Band Edge

Mode 1: CH00 (2402 MHz)

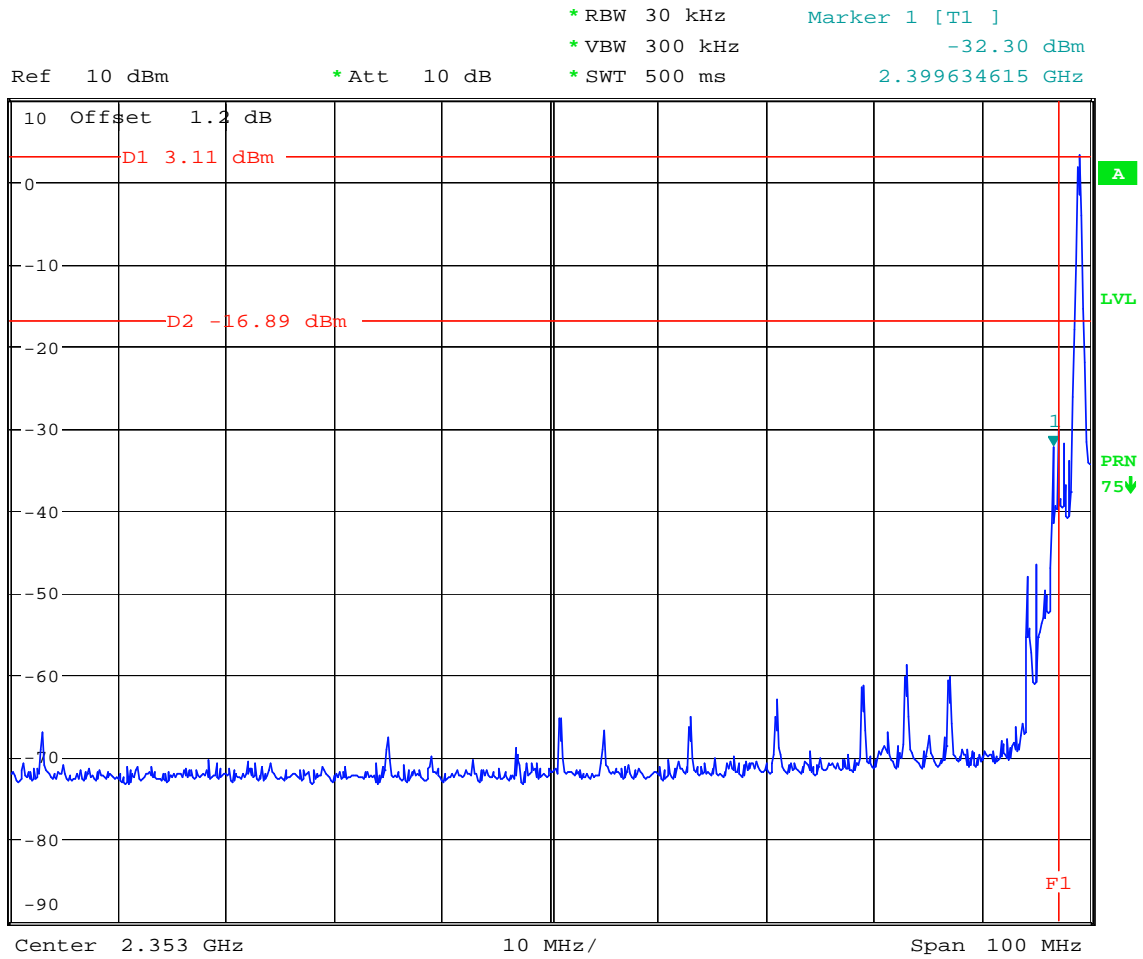

Date: 14.DEC.2005 10:35:15



Mode 3: CH78 (2480 MHz)



* RBW 100 kHz Marker 1 [T1]
* VBW 100 kHz -47.62 dBm
* SWT 500 ms 2.484371795 GHz

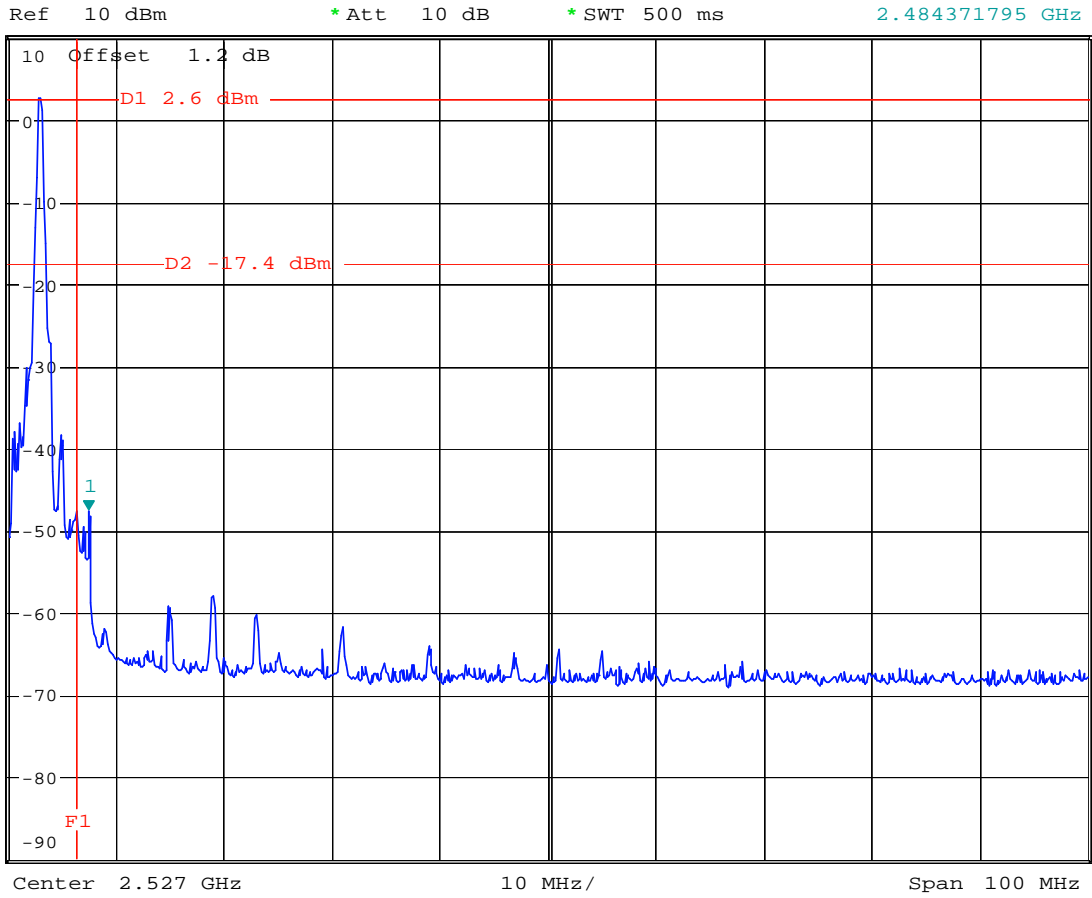

Date: 14.DEC.2005 10:31:57



5.8 Conducted Emission

5.8.1 Measuring Instruments

As described in chapter 6 of this test Report.

5.8.2 Test Procedures :

- a. The EUT was placed 0.4 meter from the conducting wall of the shielding room was kept at least 80 centimeters from any other grounded conducting surface.
- b. Connect EUT to the power port of a line impedance stabilization network (LISN).
- c. All the support units are connected to the other LISN.
- d. The LISN provides 50 ohm coupling impedance for the measuring instrument.
- e. The FCC states that a 50 ohm, 50 microhenry LISN should be used.
- f. Both sides of AC line were checked for maximum conducted interference.
- g. The frequency range from 150 kHz to 30 MHz was searched.
- h. Set the test-receiver system to Peak Detect Function and specified bandwidth with Maximum Hold Mode.



5.8.3 Test Data Test Mode 1

- Temperature: 24°C
- Relative Humidity: 51%
- Test Engineer : Jay
- Test Mode : Mode 1

■ The test that passed at minimum margin was marked by the frame in the following table.

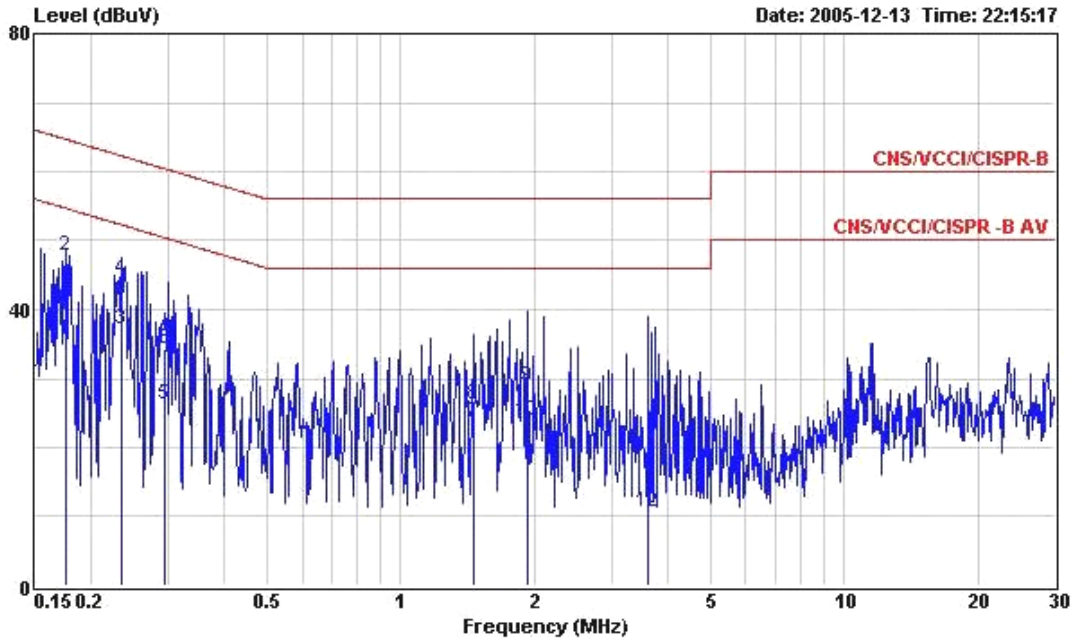

Site : CO01-HY
 Condition : CNS/VCCI/CISPR-B 2001/004 200505 LINE
 EUT : Bluetooth Module
 Power : 120V/60Hz
 Model : FD5D0903
 Memo : BT RX MODE CH39_2441MHZ
 Memo :
 Memo :

	Freq	Level	Over	Limit	Read	Probe	Cable	
	MHz	dBuV	Limit	Line	Level	Factor	Loss	Remark
			dB	dBuV	dBuV	dB	dB	
1	0.176	35.50	-19.17	54.67	35.41	0.06	0.03	Average
2	0.176	47.82	-16.85	64.67	47.73	0.06	0.03	QP
3	0.235	37.22	-15.05	52.27	37.14	0.06	0.02	Average
4	0.235	44.41	-17.86	62.27	44.33	0.06	0.02	QP
5	0.295	26.13	-24.26	50.39	26.04	0.06	0.03	Average
6	0.295	34.17	-26.22	60.39	34.08	0.06	0.03	QP
7	1.460	23.72	-22.28	46.00	23.50	0.11	0.11	Average
8	1.460	26.33	-29.67	56.00	26.11	0.11	0.11	QP
9	1.930	28.81	-27.19	56.00	28.58	0.11	0.12	QP
10	1.930	23.92	-22.08	46.00	23.69	0.11	0.12	Average
11	3.620	18.63	-37.37	56.00	18.28	0.20	0.15	QP
12	3.620	10.64	-35.36	46.00	10.29	0.20	0.15	Average

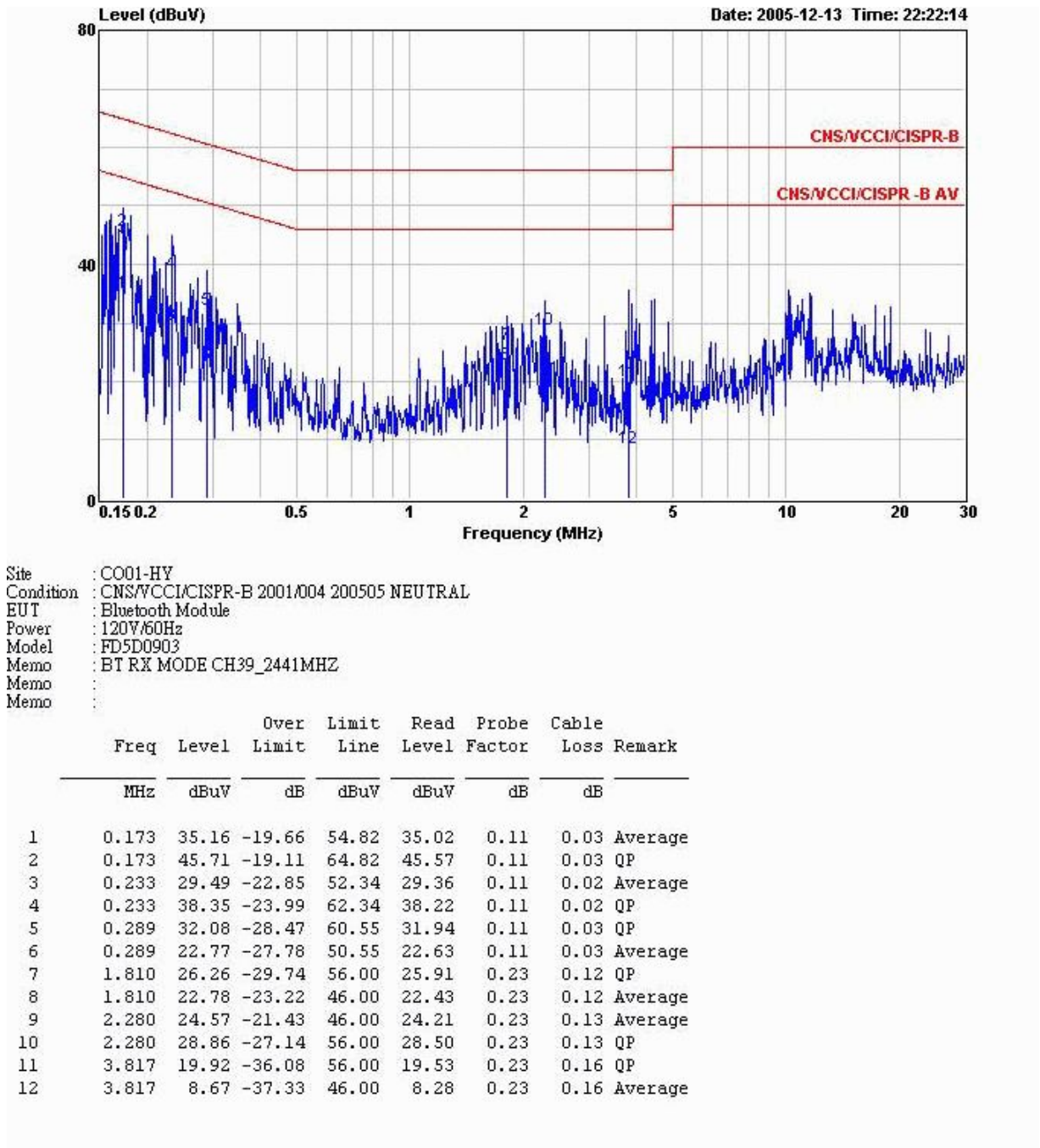

Site : CO01-HY
 Condition : CNS/VCCI/CISPR-B 2001/004 200505 NEUTRAL
 EUT : Bluetooth Module
 Power : 120V/60Hz
 Model : FD5D0903
 Memo : BT RX MODE CH39_2441MHZ
 Memo :
 Memo :

	Freq	Level	Over	Limit	Read	Probe	Cable	
	MHz	dBuV	Limit	Line	Level	Factor	Loss	Remark
			dB	dBuV	dBuV	dB	dB	
1	0.173	35.16	-19.66	54.82	35.02	0.11	0.03	Average
2	0.173	45.71	-19.11	64.82	45.57	0.11	0.03	QP
3	0.233	29.49	-22.85	52.34	29.36	0.11	0.02	Average
4	0.233	38.35	-23.99	62.34	38.22	0.11	0.02	QP
5	0.289	32.08	-28.47	60.55	31.94	0.11	0.03	QP
6	0.289	22.77	-27.78	50.55	22.63	0.11	0.03	Average
7	1.810	26.26	-29.74	56.00	25.91	0.23	0.12	QP
8	1.810	22.78	-23.22	46.00	22.43	0.23	0.12	Average
9	2.280	24.57	-21.43	46.00	24.21	0.23	0.13	Average
10	2.280	28.86	-27.14	56.00	28.50	0.23	0.13	QP
11	3.817	19.92	-36.08	56.00	19.53	0.23	0.16	QP
12	3.817	8.67	-37.33	46.00	8.28	0.23	0.16	Average



5.9 Radiated Emission Measurement

5.9.1 Measuring Instruments

As described in chapter 6 of this Report.

5.9.2 Test Procedures

1. The EUT was placed on a rotatable table top 0.8 meter above ground.
2. The EUT was set 3 meters from the interference receiving antenna which was mounted on the top of a variable height antenna tower.
3. The table was rotated 360 degrees to determine the position of the highest radiation.
4. The antenna is a broadband antenna and its height is varied between one meter and four meters above ground to find the maximum value of the field strength for both horizontal polarization and vertical polarization of the antenna.
5. For each suspected emission, the EUT was arranged to its worst case and then tune the antenna tower (from 1 m to 4 m) and turntable (from 0 degree to 360 degrees) to find the maximum reading.
6. Set the test-receiver system to Peak or CISPR quasi-peak Detect Function and specified bandwidth with Maximum Hold Mode.
7. For testing below 1GHz, If the emission level of the EUT in peak mode was 3 dB lower than the limit specified, then testing will be stopped and peak values of EUT will be reported, otherwise, the emissions will be repeated one by one using the quasi-peak method and reported.
8. For testing above 1GHz, the emission level of the EUT in peak mode was 20dB lower than average limit (that means the emission level in average mode also complies with the limit in average mode), then testing will be stopped and peak values of EUT will be reported, otherwise, the emissions will be measured in average mode again and reported.

5.9.3 Typical Test Setup Layout of Radiated Emission

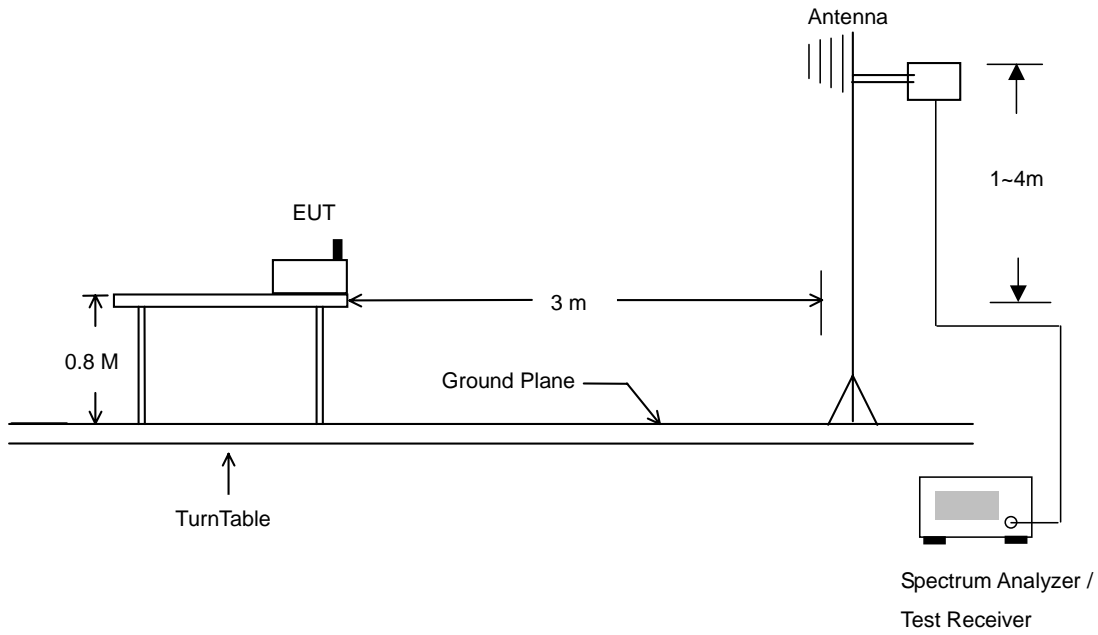



5.9.4 Test Data

- Temperature : 24 °C
- Relating Humidity : 53 %
- Test Enginner : Jay
- Test Mode : Mode 1
- Polarization : Horizontal

The test that passed at the minimum margin was marked by the frame in the following test record

	Freq	Level	Over Limit	Limit Line	ReadAntenna Level	Antenna Factor	Cable Loss	Preamp Factor	Ant Pos	Table Pos	Remark
	MHz	dBuV/m	dB	dBuV/m	dBuV	dB/m	dB	dB	cm	deg	
1	2390.00	50.40	-23.60	74.00	51.11	30.48	4.26	35.46	200	0	Peak
2	2390.00	39.65	-14.35	54.00	40.36	30.48	4.26	35.46	157	328	Average
3 X	2398.00	70.48			71.19	30.48	4.26	35.46	157	328	Average
4 @	2398.00	99.05			99.76	30.48	4.26	35.46	200	0	Peak
5	2494.00	50.74	-23.26	74.00	51.48	30.40	4.39	35.53	200	0	Peak
6	2494.00	39.23	-14.77	54.00	39.97	30.40	4.39	35.53	157	328	Average

Remark: #3 and #4 Fundamental Signal

	Freq	Level	Over Limit	Limit Line	ReadAntenna Level	Antenna Factor	Cable Loss	Preamp Factor	Ant Pos	Table Pos	Remark
	MHz	dBuV/m	dB	dBuV/m	dBuV	dB/m	dB	dB	cm	deg	
1	4804.00	54.17	-19.83	74.00	50.90	33.16	6.21	36.10	200	0	Peak
2	4804.00	41.99	-12.01	54.00	38.72	33.16	6.21	36.10	116	117	Average
3	4844.00	49.21	-24.79	74.00	45.81	33.27	6.27	36.14	200	0	Peak
4	4844.00	36.49	-17.51	54.00	33.09	33.27	6.27	36.14	116	117	Average

- Test Mode : Mode 1
- Polarization : Vertical

The test that passed at minimum margin was marked by the frame in the following table.

	Freq	Level	Over Limit	Limit Line	ReadAntenna Level	Antenna Factor	Cable Loss	Preamp Factor	Ant Pos	Table Pos	Remark
	MHz	dBuV/m	dB	dBuV/m	dBuV	dB/m	dB	dB	cm	deg	
1	2390.00	51.22	-22.78	74.00	51.93	30.48	4.26	35.46	200	0	Peak
2	2390.00	39.55	-14.45	54.00	40.26	30.48	4.26	35.46	100	241	Average
3 X	2398.00	70.10			70.81	30.48	4.26	35.46	100	241	Average
4 X	2398.00	99.00			99.71	30.48	4.26	35.46	200	0	Peak
5	2500.00	50.42	-23.58	74.00	51.16	30.40	4.39	35.53	200	0	Peak
6	2500.00	39.46	-14.54	54.00	40.20	30.40	4.39	35.53	100	241	Average

Remark: #3 and #4 Fundamental Signal

	Freq	Level	Over Limit	Limit Line	ReadAntenna Level	Antenna Factor	Cable Loss	Preamp Factor	Ant Pos	Table Pos	Remark
	MHz	dBuV/m	dB	dBuV/m	dBuV	dB/m	dB	dB	cm	deg	
1	4804.00	57.90	-16.10	74.00	54.63	33.16	6.21	36.10	200	360	Peak
2	4804.00	45.81	-8.19	54.00	42.54	33.16	6.21	36.10	135	318	Average



- Test Mode : Mode 2
- Polarization : Horizontal

The test that passed at minimum margin was marked by the frame in the following table.

	Freq	Level	Over Limit	Limit Line	ReadAntenna Level	Antenna Factor	Cable Loss	Preamp Factor	Ant Pos	Table Pos	Remark
	MHz	dBuV/m	dB	dBuV/m	dBuV	dB/m	dB	dB	cm	deg	
1 @	56.19	31.22	-8.78	40.00	53.00	7.86	1.80	31.44	400	0	Peak
2	226.83	33.91	-12.09	46.00	51.42	10.00	3.73	31.24	400	0	Peak
3	257.88	35.27	-10.73	46.00	49.62	12.67	4.01	31.02	400	0	Peak

	Freq	Level	Over Limit	Limit Line	ReadAntenna Level	Antenna Factor	Cable Loss	Preamp Factor	Ant Pos	Table Pos	Remark
	MHz	dBuV/m	dB	dBuV/m	dBuV	dB/m	dB	dB	cm	deg	
1	768.30	35.80	-10.20	46.00	37.95	20.98	7.35	30.48	100	0	Peak
2 @	794.90	37.66	-8.34	46.00	38.61	21.76	7.44	30.15	100	0	Peak
3 @	925.80	38.31	-7.69	46.00	39.52	20.73	8.17	30.12	100	0	Peak

	Freq	Level	Over Limit	Limit Line	ReadAntenna Level	Antenna Factor	Cable Loss	Preamp Factor	Ant Pos	Table Pos	Remark
	MHz	dBuV/m	dB	dBuV/m	dBuV	dB/m	dB	dB	cm	deg	
1	2348.00	50.96	-23.04	74.00	51.66	30.52	4.20	35.42	0	0	Peak
2	2348.00	38.39	-15.61	54.00	39.09	30.52	4.20	35.42	126	332	Average
3 @	2438.00	96.41			97.15	30.44	4.29	35.47	0	0	Peak
4 @	2438.00	70.23			70.97	30.44	4.29	35.47	126	322	Average
5	2498.00	50.34	-23.66	74.00	51.08	30.40	4.39	35.53	0	0	Peak
6	2498.00	39.22	-14.78	54.00	39.96	30.40	4.39	35.53	126	322	Average

Remark: #3 and #4 Fundamental Signal

	Freq	Level	Over Limit	Limit Line	ReadAntenna Level	Antenna Factor	Cable Loss	Preamp Factor	Ant Pos	Table Pos	Remark
	MHz	dBuV/m	dB	dBuV/m	dBuV	dB/m	dB	dB	cm	deg	
1	4878.00	52.37	-21.63	74.00	48.85	33.39	6.30	36.16	200	0	Peak
2	4878.00	41.64	-12.36	54.00	38.11	33.39	6.30	36.16	100	114	Average



- Test Mode : Mode 2
- Polarization : Vertical

The test that passed at minimum margin was marked by the frame in the following table.

	Freq	Level	Over Limit	Limit Line	ReadAntenna Level	Antenna Factor	Cable Loss	Preamp Factor	Ant Pos	Table Pos	Remark
	MHz	dBuV/m	dB	dBuV/m	dBuV	dB/m	dB	dB	cm	deg	
1 @	46.74	33.64	-6.36	40.00	52.16	11.38	1.66	31.57	400	0	Peak
2	132.33	34.53	-8.97	43.50	51.83	11.52	2.77	31.59	400	0	Peak
3	259.23	37.02	-8.98	46.00	51.25	12.78	4.02	31.03	400	0	Peak

	Freq	Level	Over Limit	Limit Line	ReadAntenna Level	Antenna Factor	Cable Loss	Preamp Factor	Ant Pos	Table Pos	Remark
	MHz	dBuV/m	dB	dBuV/m	dBuV	dB/m	dB	dB	cm	deg	
1	661.90	35.26	-10.74	46.00	40.59	18.61	6.71	30.65	100	0	Peak
2	701.80	36.58	-9.42	46.00	41.15	19.10	6.94	30.60	100	0	Peak
3	731.90	36.87	-9.13	46.00	40.40	19.96	7.06	30.55	100	0	Peak

	Freq	Level	Over Limit	Limit Line	ReadAntenna Level	Antenna Factor	Cable Loss	Preamp Factor	Ant Pos	Table Pos	Remark
	MHz	dBuV/m	dB	dBuV/m	dBuV	dB/m	dB	dB	cm	deg	
1	2314.00	50.76	-23.24	74.00	51.45	30.55	4.17	35.40	200	0	Peak
2	2314.00	39.16	-14.84	54.00	39.90	30.44	4.29	35.47	100	239	Average
3 @	2438.00	99.33			100.07	30.44	4.29	35.47	200	0	Peak
4 @	2438.00	70.71			71.45	30.44	4.29	35.47	100	239	Average
5	2494.00	50.35	-23.65	74.00	51.09	30.40	4.39	35.53	200	0	Peak
6	2494.00	39.19	-14.81	54.00	39.93	30.40	4.39	35.53	100	239	Average

Remark: #3 and #4 Fundamental Signal

	Freq	Level	Over Limit	Limit Line	ReadAntenna Level	Antenna Factor	Cable Loss	Preamp Factor	Ant Pos	Table Pos	Remark
	MHz	dBuV/m	dB	dBuV/m	dBuV	dB/m	dB	dB	cm	deg	
1	4878.00	57.78	-16.22	74.00	54.25	33.39	6.30	36.16	200	360	Peak
2 @	4878.00	46.25	-7.75	54.00	42.72	33.39	6.30	36.16	132	310	Average



- Test Mode : Mode 3
- Polarization : Horizontal

The test that passed at minimum margin was marked by the frame in the following table.

	Freq	Level	Over Limit	Limit Line	Read Level	Antenna Factor	Cable Loss	Preamp Factor	Ant Pos	Table Pos	Remark
	MHz	dBuV/m	dB	dBuV/m	dBuV	dB/m	dB	dB	cm	deg	
1 @	2354.00	51.54	-22.46	74.00	52.25	30.51	4.20	35.42	200	360	Peak
2 @	2354.00	39.43	-14.57	54.00	40.14	30.51	4.20	35.42	100	60	Average
3 @	2478.00	68.40			69.14	30.41	4.36	35.51	100	60	Average
4 @	2478.00	93.49			94.22	30.41	4.36	35.51	200	360	Peak
5 @	2483.50	72.94	-1.06	74.00	73.67	30.41	4.36	35.51	200	360	Peak
6 @	2483.50	45.43	-8.57	54.00	46.17	30.41	4.36	35.51	100	60	Average

Remark: #3 and #4 Fundamental Signal.

	Freq	Level	Over Limit	Limit Line	Read Level	Antenna Factor	Cable Loss	Preamp Factor	Ant Pos	Table Pos	Remark
	MHz	dBuV/m	dB	dBuV/m	dBuV	dB/m	dB	dB	cm	deg	
1 @	4958.00	50.63	-23.37	74.00	46.79	33.68	6.39	36.23	200	0	Peak
2 @	4958.00	40.32	-13.68	54.00	36.47	33.68	6.39	36.23	120	107	Average

- Test Mode : Mode 3
- Polarization : Vertical

The test that passed at minimum margin was marked by the frame in the following table.

	Freq	Level	Over Limit	Limit Line	Read Level	Antenna Factor	Cable Loss	Preamp Factor	Ant Pos	Table Pos	Remark
	MHz	dBuV/m	dB	dBuV/m	dBuV	dB/m	dB	dB	cm	deg	
1 @	2384.00	51.66	-22.34	74.00	52.38	30.50	4.23	35.44	200	0	Peak
2 @	2384.00	39.59	-14.41	54.00	40.30	30.50	4.23	35.44	100	240	Average
3 @	2478.00	69.70			70.44	30.41	4.36	35.51	100	240	Average
4 @	2478.00	95.29			96.02	30.41	4.36	35.51	200	0	Peak
5 @	2483.50	70.88	-3.12	74.00	71.62	30.41	4.36	35.51	200	0	Peak
6 @	2483.50	47.17	-6.83	54.00	47.91	30.41	4.36	35.51	100	240	Average

Remark: #3 and #4 Fundamental Signal

	Freq	Level	Over Limit	Limit Line	Read Level	Antenna Factor	Cable Loss	Preamp Factor	Ant Pos	Table Pos	Remark
	MHz	dBuV/m	dB	dBuV/m	dBuV	dB/m	dB	dB	cm	deg	
1 @	4958.00	55.72	-18.28	74.00	51.87	33.68	6.39	36.23	200	360	Peak
2 @	4958.00	43.82	-10.18	54.00	39.97	33.68	6.39	36.23	100	52	Average



- Test Mode : Mode 4
- Polarization : Horizontal

The test that passed at minimum margin was marked by the frame in the following table.

	Freq	Level	Over Limit	Limit Line	ReadAntenna Level	Antenna Factor	Cable Loss	Preamp Factor	Ant Pos	Table Pos	Remark
	MHz	dBuV/m	dB	dBuV/m	dBuV	dB/m	dB	dB	cm	deg	
1	31.89	22.86	-17.14	40.00	34.95	18.07	1.39	31.55	400	0	Peak
2	116.94	30.92	-12.58	43.50	47.25	12.49	2.59	31.42	400	0	Peak
3 @	193.89	31.67	-11.83	43.50	49.76	9.68	3.45	31.21	400	0	Peak
4	257.88	29.61	-16.39	46.00	43.95	12.67	4.01	31.02	400	0	Peak

	Freq	Level	Over Limit	Limit Line	ReadAntenna Level	Antenna Factor	Cable Loss	Preamp Factor	Ant Pos	Table Pos	Remark
	MHz	dBuV/m	dB	dBuV/m	dBuV	dB/m	dB	dB	cm	deg	
1 @	731.90	34.48	-11.52	46.00	38.00	19.96	7.06	30.55	100	0	Peak
2 @	798.40	36.65	-9.35	46.00	37.50	21.84	7.45	30.13	100	0	Peak
3 @	815.90	34.69	-11.31	46.00	35.97	21.60	7.53	30.41	100	0	Peak

	Freq	Level	Over Limit	Limit Line	ReadAntenna Level	Antenna Factor	Cable Loss	Preamp Factor	Ant Pos	Table Pos	Remark
	MHz	dBuV/m	dB	dBuV/m	dBuV	dB/m	dB	dB	cm	deg	
1	2390.00	53.20	-20.80	74.00	53.91	30.48	4.26	35.46	200	0	Peak
2	2390.00	38.54	-15.46	54.00	39.25	30.48	4.26	35.46	100	64	Average
3 @	2398.00	67.71			68.42	30.48	4.26	35.46	100	64	Average
4 @	2398.00	95.81			96.52	30.48	4.26	35.46	200	0	Peak
5	2484.00	50.16	-23.84	74.00	50.90	30.41	4.36	35.51	200	0	Peak
6	2484.00	38.43	-15.57	54.00	39.17	30.41	4.36	35.51	100	64	Average

Remark: #3 and #4 Fundamental Signal

	Freq	Level	Over Limit	Limit Line	ReadAntenna Level	Antenna Factor	Cable Loss	Preamp Factor	Ant Pos	Table Pos	Remark
	MHz	dBuV/m	dB	dBuV/m	dBuV	dB/m	dB	dB	cm	deg	
1	4804.00	53.50	-20.50	74.00	50.29	33.10	6.21	36.10	200	0	Peak
2 @	4804.00	44.16	-9.84	54.00	40.95	33.10	6.21	36.10	114	109	Average



- Test Mode : Mode 4
- Polarization : Vertical

The test that passed at minimum margin was marked by the frame in the following table.

	Freq	Level	Over Limit	Limit Line	ReadAntenna Level	Antenna Factor	Cable Loss	Preamp Factor	Ant Pos	Table Pos	Remark
	MHz	dBuV/m	dB	dBuV/m	dBuV	dB/m	dB	dB	cm	deg	
1 @	31.89	35.66	-4.34	40.00	47.76	18.07	1.39	31.55	400	0	Peak
2 @	132.33	34.93	-8.57	43.50	52.24	11.52	2.77	31.59	400	0	Peak
3 @	258.69	36.38	-9.62	46.00	50.61	12.78	4.02	31.03	400	0	Peak

	Freq	Level	Over Limit	Limit Line	ReadAntenna Level	Antenna Factor	Cable Loss	Preamp Factor	Ant Pos	Table Pos	Remark
	MHz	dBuV/m	dB	dBuV/m	dBuV	dB/m	dB	dB	cm	deg	
1 @	665.40	34.64	-11.36	46.00	39.90	18.66	6.73	30.64	100	0	Peak
2 @	798.40	35.55	-10.45	46.00	36.39	21.84	7.45	30.13	100	0	Peak
3 @	929.30	35.58	-10.42	46.00	36.69	20.82	8.19	30.12	100	0	Peak

	Freq	Level	Over Limit	Limit Line	ReadAntenna Level	Antenna Factor	Cable Loss	Preamp Factor	Ant Pos	Table Pos	Remark
	MHz	dBuV/m	dB	dBuV/m	dBuV	dB/m	dB	dB	cm	deg	
1	1594.00	49.28	-24.72	74.00	54.08	27.36	3.46	35.62	200	0	Peak
2	1594.00	36.62	-17.38	54.00	41.42	27.36	3.46	35.62	100	257	Average
3	2390.00	38.66	-15.34	54.00	39.37	30.48	4.26	35.46	100	193	Average
4	2390.00	51.13	-22.87	74.00	51.84	30.48	4.26	35.46	200	0	Peak
5 @	2398.00	93.25			93.96	30.48	4.26	35.46	200	0	Peak
6 @	2398.00	66.94			67.65	30.48	4.26	35.46	100	193	Average
7	2494.00	38.39	-15.61	54.00	39.13	30.40	4.39	35.53	100	193	Average
8	2494.00	49.88	-24.12	74.00	50.62	30.40	4.39	35.53	200	0	Peak

Remark: #5 and #6 Fundamental Signal

	Freq	Level	Over Limit	Limit Line	ReadAntenna Level	Antenna Factor	Cable Loss	Preamp Factor	Ant Pos	Table Pos	Remark
	MHz	dBuV/m	dB	dBuV/m	dBuV	dB/m	dB	dB	cm	deg	
1	4804.00	61.10	-12.90	74.00	57.89	33.10	6.21	36.10	200	360	Peak
2 @	4804.00	46.09	-7.91	54.00	42.88	33.10	6.21	36.10	100	312	Average



- Test Mode : Mode 5
- Polarization : Horizontal

The test that passed at minimum margin was marked by the frame in the following table.

	Freq	Level	Over Limit	Limit Line	ReadAntenna Level	Antenna Factor	Cable Loss	Preamp Factor	Ant Pos	Table Pos	Remark
	MHz	dBuV/m	dB	dBuV/m	dBuV	dB/m	dB	dB	cm	deg	
1 @	199.8	36.89	-6.61	43.50	53.12	9.93	2.52	28.68	100	0	Peak
2	258.7	39.31	-6.69	46.00	52.63	12.78	2.87	28.97	100	0	Peak
3	293.0	39.36	-6.64	46.00	52.14	12.93	3.19	28.91	100	0	Peak

	Freq	Level	Over Limit	Limit Line	ReadAntenna Level	Antenna Factor	Cable Loss	Preamp Factor	Ant Pos	Table Pos	Remark
	MHz	dBuV/m	dB	dBuV/m	dBuV	dB/m	dB	dB	cm	deg	
1	2340.0	39.32	-14.68	54.00	40.72	30.24	3.78	35.42	108	312	Average
2	2340.0	50.42	-23.58	74.00	51.82	30.24	3.78	35.42	100	360	Peak
3 @	2402.0	91.84			93.19	30.27	3.84	35.46	100	360	Peak
4 @	2402.0	64.97			66.33	30.26	3.84	35.46	108	312	Average
5 @	2462.0	103.43			104.75	30.29	3.89	35.49	100	360	Peak
6 @	2462.0	98.78			100.10	30.29	3.89	35.49	108	312	Average
7	2488.0	38.91	-15.09	54.00	40.22	30.30	3.90	35.51	108	312	Average
8	2488.0	48.97	-25.03	74.00	50.28	30.30	3.92	35.53	100	360	Peak

Remark: #3 ~ #6 Fundamental Signal

	Freq	Level	Over Limit	Limit Line	ReadAntenna Level	Antenna Factor	Cable Loss	Preamp Factor	Ant Pos	Table Pos	Remark
	MHz	dBuV/m	dB	dBuV/m	dBuV	dB/m	dB	dB	cm	deg	
1	2339.5	50.42	-23.58	74.00	51.82	30.24	3.78	35.42	100	0	Peak
2	2339.5	39.32	-14.68	54.00	40.72	30.24	3.78	35.42	108	312	Average

	Freq	Level	Over Limit	Limit Line	ReadAntenna Level	Antenna Factor	Cable Loss	Preamp Factor	Ant Pos	Table Pos	Remark
	MHz	dBuV/m	dB	dBuV/m	dBuV	dB/m	dB	dB	cm	deg	
1	2487.7	48.97	-25.03	74.00	50.28	30.30	3.90	35.51	100	0	Peak
2	2487.7	38.91	-15.09	54.00	40.22	30.30	3.90	35.51	108	312	Average



- Test Mode : Mode 5
- Polarization : Vertical

The test that passed at minimum margin was marked by the frame in the following table.

	Freq	Level	Over Limit	Limit Line	ReadAntenna Level	Antenna Factor	Cable Loss	Preamp Factor	Ant Pos	Table Pos	Remark
	MHz	dBuV/m	dB	dBuV/m	dBuV	dB/m	dB	dB	cm	deg	
1 @	252.5	40.52	-5.48	46.00	54.60	11.96	2.94	28.98	100	0	QP
2 @	257.9	42.18	-3.82	46.00	55.60	12.67	2.88	28.97	100	0	QP
3 @	263.3	40.40	-5.60	46.00	53.60	12.90	2.86	28.96	100	0	QP

	Freq	Level	Over Limit	Limit Line	ReadAntenna Level	Antenna Factor	Cable Loss	Preamp Factor	Ant Pos	Table Pos	Remark
	MHz	dBuV/m	dB	dBuV/m	dBuV	dB/m	dB	dB	cm	deg	
1 @	301.4	42.21	-3.79	46.00	54.84	13.00	3.27	28.90	100	360	Peak
2 @	306.3	42.76	-3.24	46.00	55.34	13.14	3.19	28.91	100	360	Peak
3 @	332.9	39.44	-6.56	46.00	51.12	13.91	3.39	28.97	100	360	Peak

	Freq	Level	Over Limit	Limit Line	ReadAntenna Level	Antenna Factor	Cable Loss	Preamp Factor	Ant Pos	Table Pos	Remark
	MHz	dBuV/m	dB	dBuV/m	dBuV	dB/m	dB	dB	cm	deg	
1	2343.0	39.07	-14.93	54.00	40.47	30.24	3.78	35.42	100	23	Average
2	2343.0	50.59	-23.41	74.00	51.99	30.24	3.78	35.42	100	0	Peak
3 @	2402.0	98.46			99.83	30.26	3.84	35.46	100	0	Peak
4 @	2402.0	68.51			69.87	30.26	3.84	35.46	100	23	Average
5 @	2462.0	101.18			102.50	30.29	3.89	35.49	100	0	Peak
6 @	2462.0	94.27			95.59	30.29	3.89	35.49	100	23	Average
7	2499.0	48.24	-25.76	74.00	49.55	30.30	3.92	35.53	100	0	Peak
8	2499.0	38.35	-15.65	54.00	39.66	30.30	3.92	35.53	100	23	Average

Remark: #3 ~ #6 Fundamental Signal

	Freq	Level	Over Limit	Limit Line	ReadAntenna Level	Antenna Factor	Cable Loss	Preamp Factor	Ant Pos	Table Pos	Remark
	MHz	dBuV/m	dB	dBuV/m	dBuV	dB/m	dB	dB	cm	deg	
1	4804.0	55.06	-18.94	74.00	52.93	32.88	5.34	36.10	100	360	Peak
2	4804.0	42.76	-11.24	54.00	40.63	32.88	5.34	36.10	100	147	Average

	Freq	Level	Over Limit	Limit Line	ReadAntenna Level	Antenna Factor	Cable Loss	Preamp Factor	Ant Pos	Table Pos	Remark
	MHz	dBuV/m	dB	dBuV/m	dBuV	dB/m	dB	dB	cm	deg	
1	2343.0	50.59	-23.41	74.00	51.99	30.24	3.78	35.42	100	360	Peak
2	2343.0	39.07	-14.93	54.00	40.47	30.24	3.78	35.42	100	23	Average

	Freq	Level	Over Limit	Limit Line	ReadAntenna Level	Antenna Factor	Cable Loss	Preamp Factor	Ant Pos	Table Pos	Remark
	MHz	dBuV/m	dB	dBuV/m	dBuV	dB/m	dB	dB	cm	deg	
1	2498.6	48.24	-25.76	74.00	49.55	30.30	3.92	35.53	100	360	Peak
2	2498.6	38.35	-15.65	54.00	39.66	30.30	3.92	35.53	100	23	Average

Remark: There is no more obvious emission except the listings above.



- Temperature : 24~25°C
- Relating Humidity : 56~57%
- Test Engineer : Leo
- Test Mode : Mode 6
- Polarization : Horizontal

The test that passed at the minimum margin was marked by the frame in the following test record

	Freq	Level	Over Limit	Limit Line	ReadAntenna Level	Antenna Factor	Cable Loss	Preamp Factor	Ant Pos	Table Pos	Remark
	MHz	dBuV/m	dB	dBuV/m	dBuV	dB/m	dB	dB	cm	deg	
1	38.64	32.43	-7.57	40.00	46.73	14.03	0.30	28.63	100	239	Peak
2	282.99	22.35	-23.65	46.00	36.78	12.90	0.70	28.03	---	---	Peak
3	298.38	32.84	-13.16	46.00	46.92	13.19	0.70	27.97	---	---	Peak
4	640.90	24.58	-21.42	46.00	34.61	18.64	1.10	29.78	---	---	Peak
5	696.90	24.11	-21.89	46.00	34.01	18.88	1.10	29.87	---	---	Peak
6	796.30	25.72	-20.28	46.00	34.14	19.78	1.20	29.40	---	---	Peak

	Freq	Level	Over Limit	Limit Line	ReadAntenna Level	Antenna Factor	Cable Loss	Preamp Factor	Ant Pos	Table Pos	Remark
	MHz	dBuV/m	dB	dBuV/m	dBuV	dB/m	dB	dB	cm	deg	
1	2387.61	45.97	-28.03	74.00	45.87	31.86	3.92	35.68	100	0	Peak
2	2387.61	33.15	-20.85	54.00	33.05	31.86	3.92	35.68	140	279	Average
3 X	2402.00	97.80			97.68	31.88	3.92	35.68	100	0	Peak
4 X	2402.00	56.02			55.92	31.86	3.92	35.68	140	279	Average
5	2492.00	44.09	-29.91	74.00	43.74	32.00	4.05	35.70	100	0	Peak
6	2492.00	32.15	-21.85	54.00	31.80	32.00	4.05	35.70	140	279	Average
7	4806.00	54.65	-19.35	74.00	50.44	34.12	5.77	35.68	100	0	Peak
8	4806.00	43.64	-10.36	54.00	39.43	34.12	5.77	35.68	144	68	Average
9	7197.00	53.96	-20.04	74.00	47.16	35.72	7.16	36.08	100	0	Peak
10	7197.00	44.11	-9.89	54.00	37.31	35.72	7.16	36.08	100	296	Average

Remark: 1. #3 and #4 Fundamental Signal

2. There's no more obvious spurious emission except the listings above.



- Test Mode : Mode 6
- Polarization : Vertical

The test that passed at minimum margin was marked by the frame in the following table.

	Freq	Level	Over Limit	Limit Line	ReadAntenna Level	Antenna Factor	Cable Loss	Preamp Factor	Ant Pos	Table Pos	Remark
	MHz	dBuV/m	dB	dBuV/m	dBuV	dB/m	dB	dB	cm	deg	
1	39.18	28.07	-11.93	40.00	42.36	14.03	0.30	28.63	100	281	Peak
2	141.78	23.85	-19.65	43.50	41.60	10.28	0.52	28.54	---	---	Peak
3	298.38	31.89	-14.11	46.00	45.97	13.19	0.70	27.97	---	---	Peak
4	497.40	24.12	-21.88	46.00	35.26	17.38	0.97	29.50	---	---	Peak
5	619.90	29.77	-16.23	46.00	39.86	18.55	1.10	29.74	---	---	Peak
6	959.40	25.30	-20.70	46.00	31.92	20.95	1.29	28.86	---	---	Peak

	Freq	Level	Over Limit	Limit Line	ReadAntenna Level	Antenna Factor	Cable Loss	Preamp Factor	Ant Pos	Table Pos	Remark
	MHz	dBuV/m	dB	dBuV/m	dBuV	dB/m	dB	dB	cm	deg	
1	2382.01	46.59	-27.41	74.00	46.51	31.83	3.92	35.68	100	0	Peak
2	2382.01	33.43	-20.57	54.00	33.35	31.83	3.92	35.68	102	202	Average
3 @	2402.00	98.35			98.23	31.88	3.92	35.68	100	0	Peak
4 X	2402.00	57.22			57.12	31.86	3.92	35.68	102	202	Average
5	2492.00	44.43	-29.57	74.00	44.08	32.00	4.05	35.70	100	0	Peak
6	2492.00	32.06	-21.94	54.00	31.71	32.00	4.05	35.70	102	202	Average
7	4806.00	54.23	-19.77	74.00	50.02	34.12	5.77	35.68	100	0	Peak
8	4806.00	42.56	-11.44	54.00	38.35	34.12	5.77	35.68	100	325	Average
9	8496.00	53.37	-20.63	74.00	46.69	35.80	7.18	36.30	100	0	Peak
10	8496.00	43.46	-10.54	54.00	36.78	35.80	7.18	36.30	100	243	Average

Remark: 1. #3 and #4 Fundamental Signal

2. There's no more obvious spurious emission except the listings above.



- Test Mode : Mode 7
- Polarization : Horizontal

The test that passed at minimum margin was marked by the frame in the following table.

	Freq	Level	Over Limit	Limit Line	Read Level	Antenna Factor	Cable Loss	Preamp Factor	Ant Pos	Table Pos	Remark
	MHz	dBuV/m	dB	dBuV/m	dBuV	dB/m	dB	dB	cm	deg	
1	38.64	26.23	-13.77	40.00	40.52	14.03	0.30	28.63	100	268	Peak
2	283.53	29.66	-16.34	46.00	44.09	12.90	0.70	28.03	---	---	Peak
3	298.38	30.66	-15.34	46.00	44.73	13.19	0.70	27.97	---	---	Peak
4	633.90	26.65	-19.35	46.00	36.76	18.61	1.04	29.76	---	---	Peak
5	696.90	28.53	-17.47	46.00	38.43	18.88	1.10	29.87	---	---	Peak
6	796.30	26.91	-19.09	46.00	35.33	19.78	1.20	29.40	---	---	Peak

	Freq	Level	Over Limit	Limit Line	Read Level	Antenna Factor	Cable Loss	Preamp Factor	Ant Pos	Table Pos	Remark
	MHz	dBuV/m	dB	dBuV/m	dBuV	dB/m	dB	dB	cm	deg	
1	2356.00	44.36	-29.64	74.00	44.36	31.81	3.86	35.67	100	0	Peak
2	2356.00	32.26	-21.74	54.00	32.27	31.81	3.86	35.67	145	248	Average
3 X	2441.00	101.25			101.02	31.93	3.99	35.69	100	0	Peak
4 X	2441.00	57.91			57.69	31.93	3.99	35.69	145	248	Average
5	2484.00	44.85	-29.15	74.00	44.52	31.98	4.05	35.70	100	0	Peak
6	2484.00	32.28	-21.72	54.00	31.95	31.98	4.05	35.70	145	248	Average
7	4881.00	56.16	-17.84	74.00	51.84	34.15	5.82	35.65	100	0	Peak
8	4881.00	43.55	-10.45	54.00	39.23	34.15	5.82	35.65	100	262	Average
9	8712.00	53.36	-20.64	74.00	46.23	36.10	7.45	36.42	100	0	Peak
10	8712.00	43.37	-10.63	54.00	36.24	36.10	7.45	36.42	100	228	Average

Remark: 1. #3 and #4 Fundamental Signal

2. There's no more obvious spurious emission except the listings above.



- Test Mode : Mode 7
- Polarization : Vertical

The test that passed at minimum margin was marked by the frame in the following table.

	Freq	Level	Over Limit	Limit Line	ReadAntenna Level	Antenna Factor	Cable Loss	Preamp Factor	Ant Pos	Table Pos	Remark
	MHz	dBuV/m	dB	dBuV/m	dBuV	dB/m	dB	dB	cm	deg	
1	40.53	28.49	-11.51	40.00	43.75	13.01	0.30	28.57	---	---	Peak
2	140.43	23.96	-19.54	43.50	41.71	10.26	0.51	28.52	---	---	Peak
3	298.38	35.68	-10.32	46.00	49.76	13.19	0.70	27.97	100	283	Peak
4	497.40	28.88	-17.12	46.00	40.03	17.38	0.97	29.50	---	---	Peak
5	596.80	31.70	-14.30	46.00	41.96	18.43	1.00	29.70	---	---	Peak
6	624.80	30.96	-15.04	46.00	41.08	18.57	1.05	29.75	---	---	Peak

	Freq	Level	Over Limit	Limit Line	ReadAntenna Level	Antenna Factor	Cable Loss	Preamp Factor	Ant Pos	Table Pos	Remark
	MHz	dBuV/m	dB	dBuV/m	dBuV	dB/m	dB	dB	cm	deg	
1	2388.00	44.90	-29.10	74.00	44.80	31.86	3.92	35.68	100	0	Peak
2	2388.00	32.40	-21.60	54.00	32.30	31.86	3.92	35.68	102	203	Average
3 @	2441.00	101.49			101.26	31.93	3.99	35.69	100	0	Peak
4 X	2441.00	59.38			59.16	31.93	3.99	35.69	102	203	Average
5	2494.00	44.39	-29.61	74.00	44.04	32.00	4.05	35.70	100	0	Peak
6	2494.00	32.16	-21.84	54.00	31.81	32.00	4.05	35.70	102	203	Average
7	4881.00	56.29	-17.71	74.00	51.97	34.15	5.82	35.65	100	0	Peak
8	4881.00	43.80	-10.20	54.00	39.48	34.15	5.82	35.65	100	350	Average
9	8892.00	53.39	-20.61	74.00	45.90	36.34	7.68	36.53	100	0	Peak
10	8892.00	43.51	-10.49	54.00	36.02	36.34	7.68	36.53	100	227	Average

Remark: 1. #3 and #4 Fundamental Signal

2. There's no more obvious spurious emission except the listings above.



- Test Mode : Mode 8
- Polarization : Horizontal

The test that passed at minimum margin was marked by the frame in the following table.

	Freq	Level	Over Limit	Limit Line	Read Level	Antenna Factor	Cable Loss	Preamp Factor	Ant Pos	Table Pos	Remark
	MHz	dBuV/m	dB	dBuV/m	dBuV	dB/m	dB	dB	cm	deg	
1	30.00	21.37	-18.63	40.00	30.21	19.66	0.30	28.80	---	---	Peak
2	274.89	24.65	-21.35	46.00	39.28	12.73	0.70	28.06	---	---	Peak
3	298.38	39.18	-6.82	46.00	53.25	13.19	0.70	27.97	100	233	Peak
4	596.80	23.91	-22.09	46.00	34.18	18.43	1.00	29.70	---	---	Peak
5	637.40	24.80	-21.20	46.00	34.87	18.62	1.07	29.77	---	---	Peak
6	796.30	25.75	-20.25	46.00	34.17	19.78	1.20	29.40	---	---	Peak

	Freq	Level	Over Limit	Limit Line	Read Level	Antenna Factor	Cable Loss	Preamp Factor	Ant Pos	Table Pos	Remark
	MHz	dBuV/m	dB	dBuV/m	dBuV	dB/m	dB	dB	cm	deg	
1	2388.00	44.44	-29.56	74.00	44.34	31.86	3.92	35.68	100	0	Peak
2	2388.00	32.31	-21.69	54.00	32.21	31.86	3.92	35.68	108	240	Average
3 X	2480.00	101.53			101.20	31.98	4.05	35.70	100	0	Peak
4 X	2480.00	59.61			59.28	31.98	4.05	35.70	108	240	Average
5	2483.50	65.89	-8.11	74.00	65.56	31.98	4.05	35.70	100	0	Peak
6	2483.50	42.02	-11.98	54.00	41.69	31.98	4.05	35.70	108	240	Average
7	4956.00	52.82	-21.18	74.00	48.39	34.19	5.87	35.62	100	0	Peak
8	4956.00	41.53	-12.47	54.00	37.10	34.19	5.87	35.62	153	265	Average
9	7197.00	53.51	-20.49	74.00	46.71	35.72	7.16	36.08	100	0	Peak
10	7197.00	43.67	-10.33	54.00	36.87	35.72	7.16	36.08	100	281	Average

- Remark: 1. #3 and #4 Fundamental Signal
 2. There's no more obvious spurious emission except the listings above.



- Test Mode : Mode 8
- Polarization : Vertical

The test that passed at minimum margin was marked by the frame in the following table.

	Freq	Level	Over Limit	Limit Line	Read Level	Antenna Factor	Cable Loss	Preamp Factor	Ant Pos	Table Pos	Remark
	MHz	dBuV/m	dB	dBuV/m	dBuV	dB/m	dB	dB	cm	deg	
1	40.53	27.99	-12.01	40.00	43.24	13.01	0.30	28.57	---	---	Peak
2	140.43	24.29	-19.21	43.50	42.05	10.26	0.51	28.52	---	---	Peak
3	298.38	35.27	-10.73	46.00	49.34	13.19	0.70	27.97	100	215	Peak
4	589.80	29.06	-16.94	46.00	39.38	18.36	1.00	29.69	---	---	Peak
5	631.80	29.83	-16.17	46.00	39.98	18.60	1.01	29.76	---	---	Peak
6	696.90	27.13	-18.87	46.00	37.03	18.88	1.10	29.87	---	---	Peak

	Freq	Level	Over Limit	Limit Line	Read Level	Antenna Factor	Cable Loss	Preamp Factor	Ant Pos	Table Pos	Remark
	MHz	dBuV/m	dB	dBuV/m	dBuV	dB/m	dB	dB	cm	deg	
1	2388.00	44.90	-29.10	74.00	44.80	31.86	3.92	35.68	100	0	Peak
2	2388.00	32.25	-21.75	54.00	32.15	31.86	3.92	35.68	100	200	Average
3 @	2480.00	101.63			101.30	31.98	4.05	35.70	100	0	Peak
4 X	2480.00	59.98			59.65	31.98	4.05	35.70	100	200	Average
5	2483.50	64.86	-9.14	74.00	64.53	31.98	4.05	35.70	100	0	Peak
6	2483.50	41.54	-12.46	54.00	41.21	31.98	4.05	35.70	100	200	Average
7	4956.00	53.17	-20.83	74.00	48.73	34.19	5.87	35.62	100	0	Peak
8	4956.00	42.46	-11.54	54.00	38.03	34.19	5.87	35.62	100	321	Average
9	7536.00	53.52	-20.48	74.00	46.84	35.61	7.28	36.21	100	0	Peak
10	7536.00	43.43	-10.57	54.00	36.75	35.61	7.28	36.21	100	244	Average

- Remark: 1. #3 and #4 Fundamental Signal
 2. There's no more obvious spurious emission except the listings above.



- Test Mode : Mode 9
- Polarization : Horizontal

The test that passed at minimum margin was marked by the frame in the following table.

	Freq	Level	Over Limit	Limit Line	ReadAntenna Level	Antenna Factor	Cable Loss	Preamp Factor	Ant Pos	Table Pos	Remark
	MHz	dBuV/m	dB	dBuV/m	dBuV	dB/m	dB	dB	cm	deg	
1	38.64	25.89	-14.11	40.00	40.19	14.03	0.30	28.63	100	234	Peak
2	199.83	24.17	-19.33	43.50	42.62	9.30	0.60	28.36	---	---	Peak
3	298.38	24.74	-21.26	46.00	38.82	13.19	0.70	27.97	---	---	Peak
4	596.80	25.85	-20.15	46.00	36.12	18.43	1.00	29.70	---	---	Peak
5	679.40	25.47	-20.53	46.00	35.42	18.80	1.09	29.84	---	---	Peak
6	957.30	26.37	-19.63	46.00	33.03	20.94	1.27	28.87	---	---	Peak

	Freq	Level	Over Limit	Limit Line	ReadAntenna Level	Antenna Factor	Cable Loss	Preamp Factor	Ant Pos	Table Pos	Remark
	MHz	dBuV/m	dB	dBuV/m	dBuV	dB/m	dB	dB	cm	deg	
1	2390.00	44.39	-29.61	74.00	44.29	31.86	3.92	35.68	100	0	Peak
2	2390.00	32.31	-21.69	54.00	32.21	31.86	3.92	35.68	149	238	Average
3 @	2480.00	98.99			98.66	31.98	4.05	35.70	100	0	Peak
4 X	2480.00	57.53			57.20	31.98	4.05	35.70	149	238	Average
5	2483.50	64.80	-9.20	74.00	64.47	31.98	4.05	35.70	100	0	Peak
6	2483.50	41.08	-12.92	54.00	40.75	31.98	4.05	35.70	149	238	Average
7	4956.00	62.24	-11.76	74.00	57.81	34.19	5.87	35.62	100	0	Peak
8 !	4956.00	48.56	-5.44	54.00	44.13	34.19	5.87	35.62	200	309	Average
9	7221.00	53.30	-20.70	74.00	46.52	35.71	7.17	36.09	100	0	Peak
10	7221.00	43.45	-10.55	54.00	36.66	35.71	7.17	36.09	100	291	Average
11	9921.00	44.81	-29.19	74.00	83.00	-9.48	8.07	36.79	---	---	Peak

Remark: 1. #3 and #4 Fundamental Signal

2. There's no more obvious spurious emission except the listings above.



- Test Mode : Mode 9
- Polarization : Vertical

The test that passed at minimum margin was marked by the frame in the following table.

	Freq	Level	Over Limit	Limit Line	ReadAntenna Level	Antenna Factor	Cable Loss	Preamp Factor	Ant Pos	Table Pos	Remark
	MHz	dBuV/m	dB	dBuV/m	dBuV	dB/m	dB	dB	cm	deg	
1	39.99	28.76	-11.24	40.00	43.52	13.51	0.30	28.58	100	285	Peak
2	146.64	24.13	-19.37	43.50	41.84	10.35	0.56	28.62	---	---	Peak
3	298.38	24.83	-21.17	46.00	38.91	13.19	0.70	27.97	---	---	Peak
4	596.80	32.26	-13.74	46.00	42.53	18.43	1.00	29.70	---	---	Peak
5	621.30	28.66	-17.34	46.00	38.76	18.56	1.08	29.74	---	---	Peak
6	990.90	30.09	-23.91	54.00	36.36	21.18	1.30	28.75	---	---	Peak

	Freq	Level	Over Limit	Limit Line	ReadAntenna Level	Antenna Factor	Cable Loss	Preamp Factor	Ant Pos	Table Pos	Remark
	MHz	dBuV/m	dB	dBuV/m	dBuV	dB/m	dB	dB	cm	deg	
1	2342.00	44.64	-29.36	74.00	44.67	31.78	3.86	35.67	100	0	Peak
2	2342.00	32.17	-21.83	54.00	32.20	31.78	3.86	35.67	169	280	Average
3 @	2480.00	94.55			94.22	31.98	4.05	35.70	100	0	Peak
4 X	2480.00	55.14			54.81	31.98	4.05	35.70	169	280	Average
5	2483.50	60.32	-13.68	74.00	59.99	31.98	4.05	35.70	100	0	Peak
6	2483.50	39.49	-14.51	54.00	39.16	31.98	4.05	35.70	169	280	Average
7	4956.00	58.79	-15.21	74.00	54.36	34.19	5.87	35.62	100	0	Peak
8	4956.00	46.60	-7.40	54.00	42.17	34.19	5.87	35.62	132	354	Average
9	8937.00	53.68	-20.32	74.00	46.09	36.41	7.74	36.56	100	0	Peak
10	8937.00	43.70	-10.30	54.00	36.11	36.41	7.74	36.56	100	262	Average

Remark: 1. #3 and #4 Fundamental Signal

2. There's no more obvious spurious emission except the listings above.



5.10 Antenna Requirements

5.10.1 Standard Applicable

For intentional device, according to FCC 47 CFR Section 15.203, an intentional radiator shall be designed to ensure that no other antenna except assembled by the responsible party shall be used with the device.

And according to FCC 47 CFR Section 15.247 (b), if directional gain of transmitting antennas is greater than 6dBi, the power shall be reduced by the same level in dB comparing to gain minus 6dBi.

5.10.2 Antenna Connected Construction

The antenna used in this product are a dipole antenna and PIFA antenna with UML connector and it is considered to meet antenna requirement of FCC.

5.10.3 Antenna Gain

The antenna gain of EUT is less than 6dBi. Therefore, it is not necessary to reduce maximum peak output power limit.



6. List of Measuring Equipment

Instrument	Manufacturer	Model No.	Serial No.	Characteristics	Calibration Date	Due Date	Remark
EMC Receiver	R&S	ESCS 30	100174	9kHz – 2.75GHz	Oct. 19, 2005	Oct. 19, 2006	Conduction (CO01-HY)
LISN	MessTec	NNB-2/16Z	2001/009	9kHz – 30MHz	Apr. 26, 2005	Apr. 26, 2006	Conduction (CO01-HY)
LISN (Support Unit)	MessTec	NNB-2/16Z	2001/004	9kHz – 30MHz	Apr. 20, 2005	Apr. 20, 2006	Conduction (CO01-HY)
EMI Filter	LINDGREN	LRE-2060	1004	< 450Hz	N/A	N/A	Conduction (CO01-HY)
EMI Filter	LINDGREN	N6006	201052	0 – 60Hz	N/A	N/A	Conduction (CO01-HY)
RF Cable-CON	Suhner Switzerland	RG223/U	CB029	9kHz – 30MHz	Dec. 23, 2004	Dec. 23, 2005	Conduction (CO01-HY)
Spectrum Analyzer	Agilent	E4408B	MY44211028	9KHz-26.5GHz	Oct. 17, 2007	Oct. 16, 2008	Radiation (03CH06-HY)
EMI Test Receiver	R&S	ESCS30	100356	9KHz-2.75GHz	Jul. 26, 2007	Jul. 25, 2008	Radiation (03CH06-HY)
Bilog Antenna	SCHAFFNER	CBL6112B	2885	30MHz -2GHz	Dec. 01, 2007	Nov. 30, 2008	Radiation (03CH06-HY)
Double Ridge Horn Antenna	Com-Power	AH118	071025	1G~18G	Jun. 04, 2007	Jun. 03, 2008	Radiation (03CH06-HY)
SHF-EHF Horn	SCHWARZBEC K	BBHA 9170	9170-251	14G - 40G	Oct. 17, 2007	Oct. 16, 2008	Radiation (03CH06-HY)
Pre Amplifier	Agilent	8449B	3008A01917	1G - 26.5G	Nov. 22, 2007	Nov. 21, 2008	Radiation (03CH06-HY)
PreAmplifier	EMEC	PA303	PA303-SMA-0	100K~3GHz	Nov. 26, 2007	Nov. 25, 2008	Radiation (03CH06-HY)
Base Station Simulator	R & S	CMU200	103937	Third-Band	Oct. 19, 2007	Oct. 18, 2008	Radiation (03CH06-HY)



7. Uncertainty Evaluation

Uncertainty of Conducted Emission Measurement (150kHz ~ 30MHz)

Contribution	Uncertainty of x_i		$u(x_i)$
	dB	Probability Distribution	
Receiver reading	0.10	Normal(k=2)	0.05
Cable loss	0.10	Normal(k=2)	0.05
AMN insertion loss	2.50	Rectangular	0.63
Receiver Spec	1.50	Rectangular	0.43
Site imperfection	1.39	Rectangular	0.80
Mismatch	+0.34/-0.35	U-shape	0.24
Combined standard uncertainty Uc(y)	1.13		
Measuring uncertainty for a level of confidence of 95% U=2Uc(y)	2.26		

Uncertainty of Radiated Emission Measurement (30MHz ~ 1000MHz)

Contribution	Uncertainty of x_i		$u(x_i)$
	dB	Probability Distribution	
Receiver reading	0.11	Normal(k=2)	0.06
Antenna factor calibration	0.91	Normal(k=2)	0.46
Cable loss calibration	0.12	Normal(k=2)	0.06
Pre Amplifier Gain calibration	0.15	Normal(k=2)	0.08
RCV/SPA specification	2.50	Rectangular	0.72
Antenna Factor Interpolation for Frequency	1.00	Rectangular	0.29
Site imperfection	1.52	Rectangular	0.88
Mismatch	+0.45/-0.48	U-shaped	0.33
Combined standard uncertainty Uc(y)	1.30		
Measuring uncertainty for a level of confidence of 95% U=2Uc(y)	2.60		



Uncertainty of Radiated Emission Measurement (1GHz ~ 40GHz)

Contribution	Uncertainty of x_i		$u(x_i)$	C_i	$C_i * u(x_i)$
	dB	Probability Distribution			
Receiver reading	±0.10	Normal(k=1)	0.10	1	0.10
Antenna factor calibration	±1.70	Normal(k=2)	0.85	1	0.85
Cable loss calibration	±0.50	Normal(k=2)	0.25	1	0.25
Receiver Correction	±2.00	Rectangular	1.15	1	1.15
Antenna Factor Directional	±1.50	Rectangular	0.87	1	0.87
Site imperfection	±2.80	Triangular	1.14	1	1.14
Mismatch Receiver VSWR $\Gamma_1 = 0.197$ Antenna VSWR $\Gamma_2 = 0.194$ Uncertainty = $20 \log(1 - \Gamma_1 * \Gamma_2 * \Gamma_3)$	+0.34/-0.35	U-shaped	0.244	1	0.244
Combined standard uncertainty $U_c(y)$	2.36				
Measuring uncertainty for a level of confidence of 95% $U = 2U_e(y)$	4.72				

The measured result is : y dBuV \pm U dB
for a level of confidence of approximately 95% , ($k = 2$)