

FCC / IC RF Test Report

APPLICANT : PSION INC.
EQUIPMENT : EP10 Hand-Held Computer
BRAND NAME : **PSION**
MODEL NAME : 7515
FCC ID : GM37515UB
IC : 2739D-7515UB
STANDARD : FCC 47 CFR Part 2, 22(H), 24(E), 27(L)
IC RSS-132 Issue 2
IC RSS-133 Issue 5
IC RSS-139 Issue 2
CLASSIFICATION : PCS Licensed Transmitter (PCB)
Tx/Rx FREQUENCY RANGE : GSM850 : 824.2 ~ 848.8 MHz /
869.2 ~ 893.8 MHz
GSM1900 : 1850.2 ~ 1909.8 MHz /
1930.2 ~ 1989.8 MHz
WCDMA Band V : 826.4 ~ 846.6 MHz /
871.4 ~ 891.6 MHz
WCDMA Band IV : 1712.4 MHz ~ 1752.6 MHz
2112.4 MHz ~ 2152.6 MHz
WCDMA Band II : 1852.4 ~ 1907.6 MHz /
1932.4 ~ 1987.6 MHz
MAX. ERP/EIRP POWER : GSM850 (GPRS 8) : 1.0399 W
GSM850 (EDGE 8) : 0.3972 W
GSM1900 (GPRS 8) : 1.1092 W
GSM1900 (EDGE 8) : 0.4467 W
WCDMA Band V (RMC 12.2Kbps) : 0.1462 W
WCDMA Band IV (RMC 12.2Kbps) : 0.2649 W
WCDMA Band II (RMC 12.2Kbps) : 0.2667 W

The product was received on Dec. 08, 2011 and completely tested on Apr. 02, 2012. We, SPORTON INTERNATIONAL INC., would like to declare that the tested sample has been evaluated in accordance with the procedures given in ANSI / TIA / EIA-603-C-2004 and shown compliance with the applicable technical standards.

The test results in this report apply exclusively to the tested model / sample. Without written approval of SPORTON INTERNATIONAL INC., the test report shall not be reproduced except in full.

Reviewed by:



Jones Tsai / Manager



SPORTON INTERNATIONAL INC.

No. 52, Hwa Ya 1st Rd., Hwa Ya Technology Park, Kwei-Shan Hsiang, Tao Yuan Hsien, Taiwan, R.O.C.



TABLE OF CONTENTS

REVISION HISTORY..... 3

SUMMARY OF TEST RESULT 4

1 GENERAL DESCRIPTION 5

 1.1 Applicant..... 5

 1.2 Manufacturer 5

 1.3 Feature of Equipment Under Test..... 6

 1.4 Emission Designator and Maximum ERP/EIRP Power 7

 1.5 Testing Site..... 8

 1.6 Applied Standards 8

 1.7 Ancillary Equipment List..... 8

2 TEST CONFIGURATION OF EQUIPMENT UNDER TEST 9

 2.1 Test Mode..... 9

 2.2 Connection Diagram of Test System 11

3 TEST RESULT 12

 3.1 Conducted Output Power Measurement..... 12

 3.2 Effective Radiated Power and Effective Isotropic Radiated Power Measurement 14

 3.3 Occupied Bandwidth Measurement 20

 3.4 Band Edge Measurement..... 42

 3.5 Conducted Emission Measurement 57

 3.6 Field Strength of Spurious Radiation Measurement 76

 3.7 Frequency Stability Measurement..... 92

4 LIST OF MEASURING EQUIPMENTS..... 97

5 UNCERTAINTY OF EVALUATION 98

APPENDIX A. PHOTOGRAPHS OF EUT

APPENDIX B. SETUP PHOTOGRAPHS



REVISION HISTORY

REPORT NO.	VERSION	DESCRIPTION	ISSUED DATE
FG1D0814	Rev. 01	Initial issue of report	Apr. 24, 2012



SUMMARY OF TEST RESULT

Report Section	FCC Rule	IC Rule	Description	Limit	Result	Remark
3.1	§2.1046	N/A	Conducted Output Power	N/A	PASS	-
3.2	§22.913(a)(2)	RSS-132(4.4) SRSP-503(5.1.3)	Effective Radiated Power	< 7 Watts	PASS	-
3.2	§24.232(c)	RSS-133 (6.4) SRSP-510(5.1.2)	Equivalent Isotropic Radiated Power	< 2 Watts	PASS	-
3.2	§27.50(d)(2)	RSS-139 (6.4) SRSP-513(5.1.2)	Equivalent Isotropic Radiated Power	< 1 Watts	PASS	-
3.3	§2.1049 §22.917(a) §24.238(a) §27.53(g)	N/A	Occupied Bandwidth	N/A	PASS	-
3.4	§2.1051 §22.917(a) §24.238(a) §27.53(g)	RSS-132 (4.5.1) RSS-133 (6.5.1) RSS-139 (6.5)	Band Edge Measurement	< 43+10log ₁₀ (P[Watts])	PASS	-
3.5	§2.1051 §22.917(a) §24.238(a) §27.53(g)	RSS-132 (4.5.1) RSS-133 (6.5.1) RSS-139 (6.5)	Conducted Emission	< 43+10log ₁₀ (P[Watts])	PASS	-
3.6	§2.1053 §22.917(a) §24.238(a) §27.53(g)	RSS-132 (4.5.1) RSS-133 (6.5.1) RSS-139 (6.5)	Field Strength of Spurious Radiation	< 43+10log ₁₀ (P[Watts])	PASS	Under limit 28.39 dB at 5640.000 MHz
3.7	§2.1055 §22.355 §24.235 §27.54	RSS-132 (4.3) RSS-133 (6.3) RSS-139 (6.3)	Frequency Stability for Temperature & Voltage	< 2.5 ppm	PASS	-



1 General Description

1.1 Applicant

PSION INC.

2100 Meadowvale Blvd, Mississauga ON L5N 7J9, CANADA

1.2 Manufacturer

PSION INC.

2100 Meadowvale Blvd, Mississauga ON L5N 7J9, CANADA

1.3 Feature of Equipment Under Test

Product Feature & Specification	
Equipment	EP10 Hand-Held Computer
Brand Name	ASION
Model Name	7515
FCC ID	GM37515UB
IC	2739D-7515UB
Tx Frequency	GSM850 : 824 MHz ~ 849 MHz GSM1900 : 1850 MHz ~ 1910 MHz WCDMA Band V : 824 MHz ~ 849 MHz WCDMA Band IV : 1710 MHz ~ 1755 MHz WCDMA Band II : 1850 MHz ~ 1910 MHz
Rx Frequency	GSM850 : 869 MHz ~ 894 MHz GSM1900 : 1930 MHz ~ 1990 MHz WCDMA Band V : 869 MHz ~ 894 MHz WCDMA Band IV : 2110 MHz ~ 2155 MHz WCDMA Band II : 1930 MHz ~ 1990 MHz
Maximum Output Power to Antenna	GSM850 : 33.34 dBm GSM1900 : 29.63 dBm WCDMA Band V : 24.06 dBm WCDMA Band IV : 23.88 dBm WCDMA Band II : 24.30 dBm
Antenna Type	Fixed Internal Antenna
HW Version	3
SW Version	2.2.0.0
Type of Modulation	GSM: GMSK GPRS: GMSK EDGE: GMSK / 8PSK WCDMA: QPSK (Uplink) HSDPA: QPSK (Uplink) HSUPA: QPSK (Uplink)
EUT Stage	Identical Prototype

Remark: The above EUT's information was declared by manufacturer. Please refer to the specifications or user's manual for more detailed description.

List of Accessory:

Specification of Accessory		
AC Adapter 1	Brand Name	Leader
	Model Name	IU18-2050300-WP
AC Adapter 2	Brand Name	Phihong
	Model Name	PSA15R-050P
Battery	Brand Name	PSION / ETI
	Model Name	RV3010 / BP08-000760
Car Charger	Brand Name	AOEM
	Model Name	C15C-0520CD0-C0
Desktop Charger Cradle (Single Dock)	Brand Name	PSION
	Model Name	RV4000
Desktop Charger Cradle (AC Adapter)	Brand Name	FSP
	Model Name	FSP050-DBAB1
Charger Snap Module 1	Brand Name	PSION
	Model Name	RV4001
Charger Snap Module 2	Brand Name	PSION
	Model Name	RV4002
LCD Panel	Brand Name	Sharp
	Model Name	LS037V7DW01
Pouch	Brand Name	Psion
	Model Name	RV6091

Remark: For accessories equipped with this EUT, please refer to Appendix A.

1.4 Emission Designator and Maximum ERP/EIRP Power

FCC Rule	System	Type of Modulation	Emission Designator	Maximum ERP/EIRP
Part 22	GSM850 GPRS 8	GMSK	246KGXW	1.0399 W
Part 22	GSM850 EDGE 8	8PSK	248KG7W	0.3972 W
Part 22	WCDMA Band V RMC 12.2Kbps	QPSK	4M18F9W	0.1462 W
Part 24	GSM1900 GPRS 8	GMSK	248KGXW	1.1092 W
Part 24	GSM1900 EDGE 8	8PSK	248KG7W	0.4467 W
Part 24	WCDMA Band II RMC 12.2Kbps	QPSK	4M18F9W	0.2667 W
Part 27	WCDMA Band IV RMC 12.2Kbps	QPSK	4M16F9W	0.2649 W

1.5 Testing Site

Test Site	SPORTON INTERNATIONAL INC.		
Test Site Location	No. 52, Hwa Ya 1 st Rd., Hwa Ya Technology Park, Kwei-Shan Hsiang, Tao Yuan Hsien, Taiwan, R.O.C. TEL: +886-3-327-3456 FAX: +886-3-328-4978		
Test Site No.	Sporton Site No.		FCC/IC Registration No.
	TH02-HY	03CH05-HY	722060/4086B-1

1.6 Applied Standards

According to the specifications of the manufacturer, the EUT must comply with the requirements of the following standards:

- ♦ Preliminary Guidance for Receiving Applications for Certification of 3G Device. May 9, 2006.
- ♦ 47 CFR Part 2, 22(H), 24(E), 27(L)
- ♦ ANSI / TIA / EIA-603-C-2004
- ♦ FCC KDB 971168 D01 Power Meas. License Digital Systems v01
- ♦ IC RSS-132 Issue 2
- ♦ IC RSS-133 Issue 5
- ♦ IC RSS-139 Issue 2

Remark:

1. All test items were verified and recorded according to the standards and without any deviation during the test.
2. This EUT has also been tested and complied with the requirements of FCC Part 15, Subpart B, recorded in a separate test report.

1.7 Ancillary Equipment List

Item	Equipment	Trade Name	Model No.	FCC ID	Data Cable	Power Cord
1.	System Simulator	R&S	CMU200	N/A	N/A	Unshielded, 1.8 m

2 Test Configuration of Equipment Under Test

2.1 Test Mode

During all testing, EUT is in link mode with base station emulator at maximum power level. The spurious emission measurements were carried out in semi-anechoic chamber with 3-meter test range, and EUT is rotated on three test planes to find out the worst emission.

Frequency range investigated for radiated emission is as follows:

1. 30 MHz to 9000 MHz for GSM850 and WCDMA Band V.
2. 30 MHz to 18000 MHz for WCDMA Band IV.
3. 30 MHz to 19000 MHz for GSM1900 and WCDMA Band II.

Test Modes		
Band	Radiated TCs	Conducted TCs
GSM 850	<ul style="list-style-type: none"> ■ GPRS 8 Link ■ EDGE 8 Link 	<ul style="list-style-type: none"> ■ GPRS 8 Link ■ EDGE 8 Link
GSM 1900	<ul style="list-style-type: none"> ■ GPRS 8 Link ■ EDGE 8 Link 	<ul style="list-style-type: none"> ■ GPRS 8 Link ■ EDGE 8 Link
WCDMA Band V	<ul style="list-style-type: none"> ■ RMC 12.2Kbps Link 	<ul style="list-style-type: none"> ■ RMC 12.2Kbps Link
WCDMA Band IV	<ul style="list-style-type: none"> ■ RMC 12.2Kbps Link 	<ul style="list-style-type: none"> ■ RMC 12.2Kbps Link
WCDMA Band II	<ul style="list-style-type: none"> ■ RMC 12.2Kbps Link 	<ul style="list-style-type: none"> ■ RMC 12.2Kbps Link

Note:

1. The maximum power levels are GPRS multi-slot class 8 mode for GMSK link, EDGE multi-slot class 8 mode for 8PSK link, RMC 12.2Kbps mode for WCDMA band V, RMC 12.2Kbps mode for WCDMA band IV, and RMC 12.2Kbps mode for WCDMA band II, only these modes were used for all tests.
2. Because there are individual antennas for each WWAN, WLAN, and Bluetooth, the co-location test modes are not required.



The conducted power tables are as follows:

Conducted Power (*Unit: dBm)						
Band	GSM850			GSM1900		
Channel	128	189	251	512	661	810
Frequency	824.2	836.4	848.8	1850.2	1880	1909.8
GSM	33.28	33.32	32.98	29.42	29.47	29.61
GPRS 8	33.29	33.34	32.99	29.30	29.63	29.61
GPRS 10	30.01	30.20	29.85	25.78	25.74	26.05
EGPRS 8	27.03	27.01	26.96	25.06	25.08	25.30
EGPRS 10	23.88	23.83	23.79	22.00	22.02	22.24

Conducted Power (*Unit: dBm)									
Band	WCDMA Band V			WCDMA Band II			WCDMA Band IV		
Tx Channel	4132	4182	4233	9262	9400	9538	1312	1413	1513
Rx Channel	4357	4408	4458	9662	9800	9938	1537	1638	1738
Frequency	826.4	836.4	846.6	1852.4	1880	1907.6	1712.4	1732.6	1752.6
RMC 12.2K	23.95	24.06	24.02	24.30	23.60	24.16	23.59	23.88	23.63
HSDPA Subtest-1	22.40	22.51	22.44	22.63	22.11	22.76	22.22	22.45	22.36
HSDPA Subtest-2	22.41	22.56	22.42	22.65	22.09	22.74	22.21	22.41	22.27
HSDPA Subtest-3	22.40	22.54	22.43	22.60	22.04	22.76	22.18	22.53	22.39
HSDPA Subtest-4	22.39	22.50	22.41	22.63	22.1	22.74	22.61	22.77	22.54
HSUPA Subtest-1	23.21	23.59	23.39	24.28	23.48	23.38	23.65	23.78	23.86
HSUPA Subtest-2	22.42	22.59	22.68	22.57	22.24	22.67	22.13	22.16	22.36
HSUPA Subtest-3	22.50	22.84	22.76	22.5	22.68	22.65	22.63	22.84	22.59
HSUPA Subtest-4	22.46	22.59	22.51	22.78	22.51	22.65	22.36	22.83	22.29
HSUPA Subtest-5	23.91	23.79	23.94	24.14	23.53	24.20	23.64	23.84	23.87

2.2 Connection Diagram of Test System

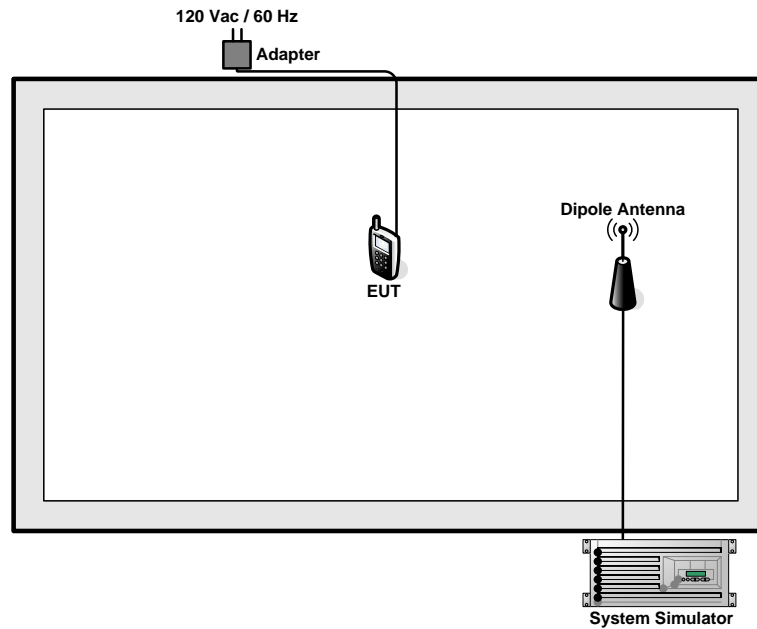

3 Test Result

3.1 Conducted Output Power Measurement

3.1.1 Description of the Conducted Output Power Measurement

A base station simulator was used to establish communication with the EUT. Its parameters were set to transmit the maximum power on the EUT. The measured power in the radio frequency on the transmitter output terminals shall be reported.

3.1.2 Measuring Instruments

See list of measuring instruments of this test report.

3.1.3 Test Procedures

1. The transmitter output port was connected to base station.
2. Set EUT at maximum power through base station.
3. Select lowest, middle, and highest channels for each band and different modulation.

3.1.4 Test Setup

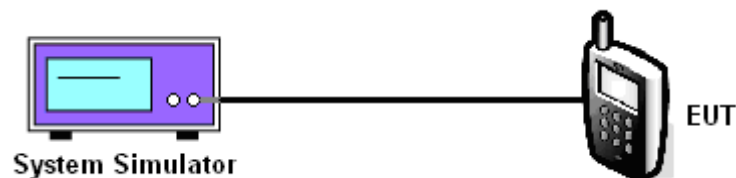

3.1.5 Test Result of Conducted Output Power

Cellular Band									
Modes	GSM850 (GPRS 8)			GSM850 (EDGE 8)			WCDMA Band V (RMC 12.2Kbps)		
Channel	128 (Low)	189 (Mid)	251 (High)	128 (Low)	189 (Mid)	251 (High)	4132 (Low)	4182 (Mid)	4233 (High)
Frequency (MHz)	824.2	836.4	848.8	824.2	836.4	848.8	826.4	836.4	846.6
Conducted Power (dBm)	33.29	33.34	32.99	27.03	27.01	26.96	23.95	24.06	24.02
Conducted Power (Watts)	2.13	2.16	1.99	0.50	0.50	0.50	0.25	0.25	0.25

PCS Band									
Modes	GSM1900 (GPRS 8)			GSM1900 (EDGE 8)			WCDMA Band II (RMC 12.2Kbps)		
Channel	512 (Low)	661 (Mid)	810 (High)	512 (Low)	661 (Mid)	810 (High)	9262 (Low)	9400 (Mid)	9538 (High)
Frequency (MHz)	1850.2	1880	1909.8	1850.2	1880	1909.8	1852.4	1880	1907.6
Conducted Power (dBm)	29.30	29.63	29.61	25.06	25.08	25.30	24.30	23.60	24.16
Conducted Power (Watts)	0.85	0.92	0.91	0.32	0.32	0.34	0.27	0.23	0.26

AWS Band			
Modes	WCDMA Band IV (RMC 12.2Kbps)		
Channel	1312(Low)	1413 (Mid)	1513 (High)
Frequency (MHz)	1712.4	1732.6	1752.6
Conducted Power (dBm)	23.59	23.88	23.63
Conducted Power (Watts)	0.23	0.24	0.23



3.2 Effective Radiated Power and Effective Isotropic Radiated Power Measurement

3.2.1 Description of the ERP/EIRP Measurement

The substitution method, in ANSI / TIA / EIA-603-C-2004, was used for ERP/EIRP measurement, and the spectrum analyzer configuration follows KDB 971168 D01 Power Meas. License Digital Systems v01. The ERP of mobile transmitters must not exceed 7 Watts and the EIRP of mobile transmitters are limited to 2 Watts.

3.2.2 Measuring Instruments

See list of measuring instruments of this test report.

3.2.3 Test Procedures

1. The EUT was placed on a non-conductive rotating platform with 0.8 meter height in a semi-anechoic chamber. The radiated emission at the fundamental frequency was measured at 3 m with a test antenna and a spectrum analyzer with RBW= 1MHz, VBW= 3MHz for GSM, RBW= 300KHz, VBW= 1MHz for WCDMA, and RMS detector settings per section 4.0 of KDB 971168 D01.
2. During the measurement, the EUT was enforced in maximum power and linked with a base station. The highest emission was recorded from analyzer power level (LVL) from the 360 degrees rotation of the turntable and the test antenna raised and lowered over a range from 1 to 4 meters in both horizontally and vertically polarized orientations.
3. Effective Isotropic Radiated Power (EIRP) was measured by substitution method according to TIA/EIA-603-C. The EUT was replaced by dipole antenna (substitution antenna) at same location, and then a known power from S.G. was applied into the dipole antenna through a Tx cable, and then recorded the maximum Analyzer reading through raised and lowered the test antenna. The correction factor (in dB) = S.G. - Tx Cable loss + Substitution antenna gain - Analyzer reading. Then the EUT's EIRP was calculated with the correction factor, $EIRP = LVL + \text{Correction factor}$ and $ERP = EIRP - 2.15$.

3.2.4 Test Setup

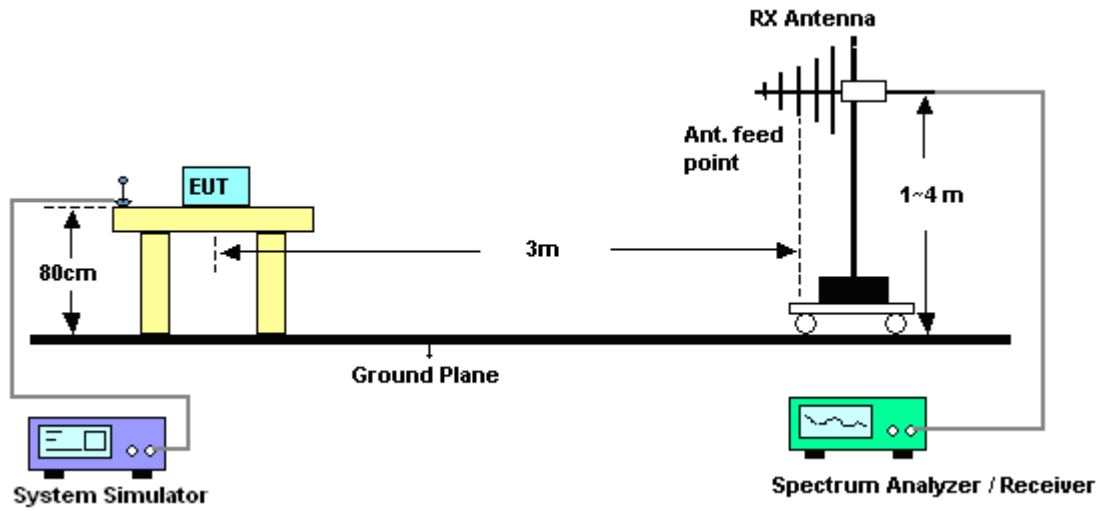

3.2.5 Test Result of ERP

GSM850 (GPRS 8) Radiated Power ERP				
Horizontal Polarization				
Frequency (MHz)	LVL (dBm)	Correction Factor (dB)	ERP (dBm)	ERP (W)
824.2	0.68	30.99	29.52	0.8954
836.4	1.23	30.89	29.97	0.9931
848.8	1.10	31.22	30.17	1.0399
Vertical Polarization				
Frequency (MHz)	LVL (dBm)	Correction Factor (dB)	ERP (dBm)	ERP (W)
824.2	-7.61	34.67	24.91	0.3097
836.4	-7.01	34.88	25.72	0.3733
848.8	-7.25	34.74	25.34	0.3420

* ERP = LVL (dBm) + Correction Factor (dB) – 2.15

GSM850 (EDGE 8) Radiated Power ERP				
Horizontal Polarization				
Frequency (MHz)	LVL (dBm)	Correction Factor (dB)	ERP (dBm)	ERP (W)
824.2	-3.70	30.99	25.14	0.3266
836.4	-3.90	30.89	24.84	0.3048
848.8	-3.08	31.22	25.99	0.3972
Vertical Polarization				
Frequency (MHz)	LVL (dBm)	Correction Factor (dB)	ERP (dBm)	ERP (W)
824.2	-11.45	34.67	21.07	0.1279
836.4	-11.77	34.88	20.96	0.1247
848.8	-11.21	34.74	21.38	0.1374

* ERP = LVL (dBm) + Correction Factor (dB) – 2.15



WCDMA Band V (RMC 12.2Kbps) Radiated Power ERP				
Horizontal Polarization				
Frequency (MHz)	LVL (dBm)	Correction Factor (dB)	ERP (dBm)	ERP (W)
826.4	-7.49	30.74	21.10	0.1288
836.4	-7.09	30.89	21.65	0.1462
846.6	-7.57	31.29	21.57	0.1435
Vertical Polarization				
Frequency (MHz)	LVL (dBm)	Correction Factor (dB)	ERP (dBm)	ERP (W)
826.4	-17.51	34.94	15.28	0.0337
836.4	-17.09	34.88	15.64	0.0366
846.6	-17.51	34.67	15.01	0.0317

* ERP = LVL (dBm) + Correction Factor (dB) – 2.15

3.2.6 Test Result of EIRP

GSM1900 (GPRS 8) Radiated Power EIRP				
Horizontal Polarization				
Frequency (MHz)	LVL (dBm)	Correction Factor (dB)	EIRP (dBm)	EIRP (W)
1850.2	-10.91	40.70	29.79	0.9528
1880.0	-11.46	41.91	30.45	1.1092
1909.8	-11.57	41.73	30.16	1.0375
Vertical Polarization				
Frequency (MHz)	LVL (dBm)	Correction Factor (dB)	EIRP (dBm)	EIRP (W)
1850.2	-16.03	42.78	26.75	0.4732
1880.0	-16.57	43.75	27.18	0.5224
1909.8	-16.44	43.06	26.62	0.4592

* EIRP = LVL (dBm) + Correction Factor (dB)

GSM1900 (EDGE 8) Radiated Power EIRP				
Horizontal Polarization				
Frequency (MHz)	LVL (dBm)	Correction Factor (dB)	EIRP (dBm)	EIRP (W)
1850.2	-15.09	40.70	25.61	0.3639
1880.0	-15.73	41.91	26.18	0.4150
1909.8	-15.23	41.73	26.50	0.4467
Vertical Polarization				
Frequency (MHz)	LVL (dBm)	Correction Factor (dB)	EIRP (dBm)	EIRP (W)
1850.2	-21.49	42.78	21.29	0.1346
1880.0	-22.30	43.75	21.45	0.1396
1909.8	-21.11	43.06	21.95	0.1567

* EIRP = LVL (dBm) + Correction Factor (dB)



WCDMA Band IV (RMC 12.2Kbps) Radiated Power EIRP				
Horizontal Polarization				
Frequency (MHz)	LVL (dBm)	Correction Factor (dB)	EIRP (dBm)	EIRP (W)
1712.4	-15.96	39.34	23.38	0.2178
1732.6	-15.66	39.89	24.23	0.2649
1752.6	-16.11	39.86	23.75	0.2371
Vertical Polarization				
Frequency (MHz)	LVL (dBm)	Correction Factor (dB)	EIRP (dBm)	EIRP (W)
1712.4	-25.83	42.85	17.02	0.0504
1732.6	-24.47	42.13	17.66	0.0583
1752.6	-24.91	41.59	16.68	0.0466

* EIRP = LVL (dBm) + Correction Factor (dB)

WCDMA Band II (RMC 12.2Kbps) Radiated Power EIRP				
Horizontal Polarization				
Frequency (MHz)	LVL (dBm)	Correction Factor (dB)	EIRP (dBm)	EIRP (W)
1852.4	-16.35	40.40	24.05	0.2541
1880.0	-17.65	41.91	24.26	0.2667
1907.6	-18.01	41.59	23.58	0.2280
Vertical Polarization				
Frequency (MHz)	LVL (dBm)	Correction Factor (dB)	EIRP (dBm)	EIRP (W)
1852.4	-24.92	42.69	17.77	0.0598
1880.0	-25.01	43.75	18.74	0.0748
1907.6	-25.38	43.02	17.64	0.0581

* EIRP = LVL (dBm) + Correction Factor (dB)

3.3 Occupied Bandwidth Measurement

3.3.1 Description of Occupied Bandwidth Measurement

The emission bandwidth is defined as the width of the signal between two points, located at the 2 sides of the carrier frequency, outside of which all emissions are attenuated at least 26 dB below the transmitter power.

3.3.2 Measuring Instruments

See list of measuring instruments of this test report.

3.3.3 Test Procedures

1. The EUT was connected to Spectrum Analyzer and Base Station via power divider.
2. The 99% and 26 dB occupied bandwidth (BW) of the middle channel for the highest RF powers were measured.

3.3.4 Test Setup

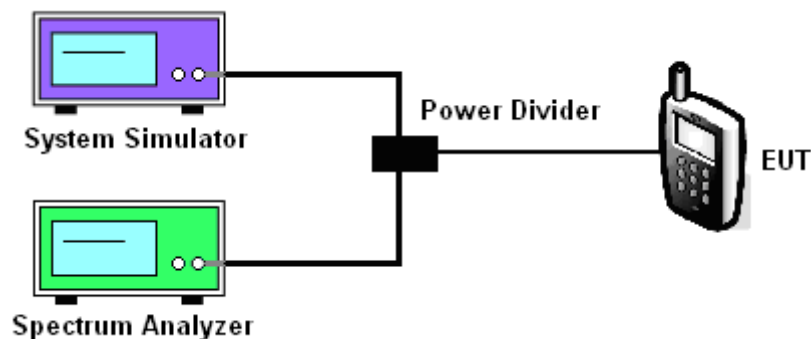



3.3.5 Test Result (Plots) of Occupied Bandwidth

Band :	GSM 850	Power Stage :	High
Test Mode :	GPRS 8 Link		

99% Occupied Bandwidth Plot on Channel 128

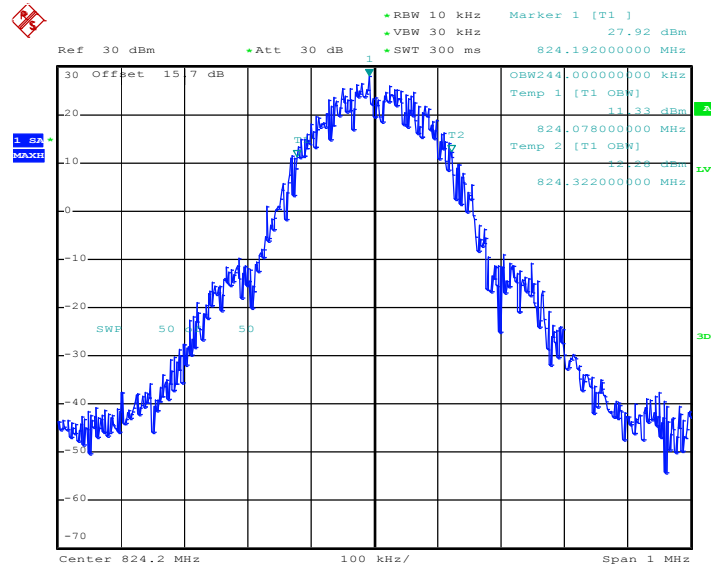

Date: 28.MAR.2012 10:37:52

26dB Bandwidth Plot on Channel 128

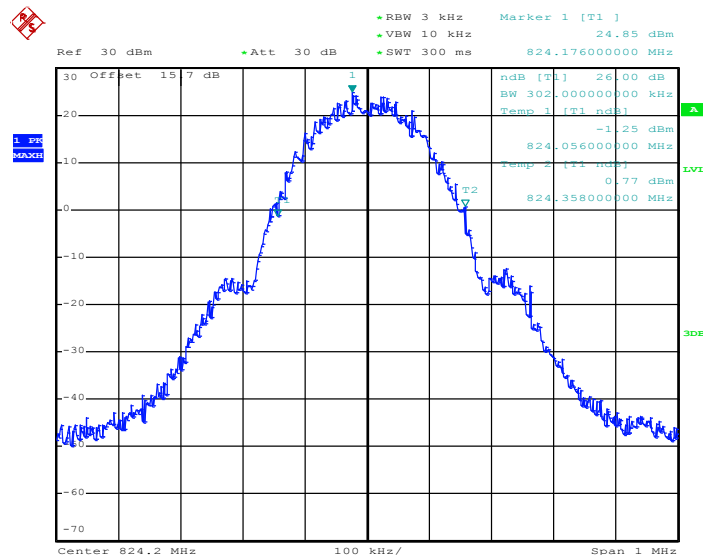

Date: 28.MAR.2012 10:35:21



99% Occupied Bandwidth Plot on Channel 189

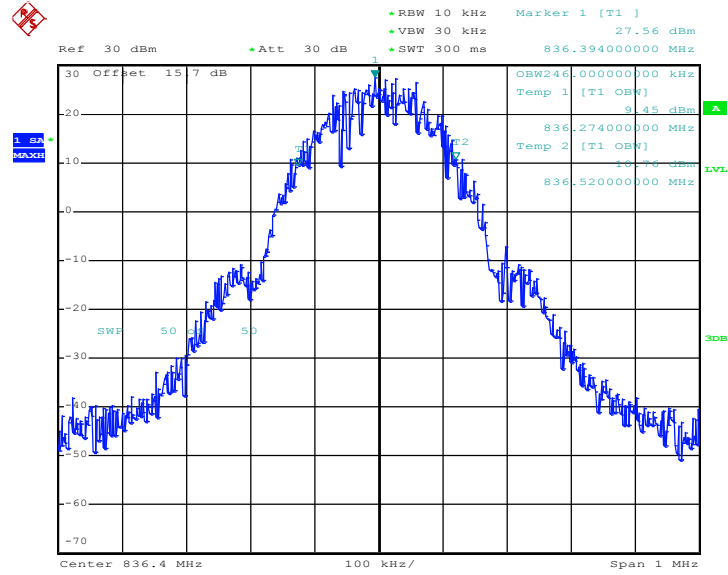

Date: 28.MAR.2012 10:38:12

26dB Bandwidth Plot on Channel 189

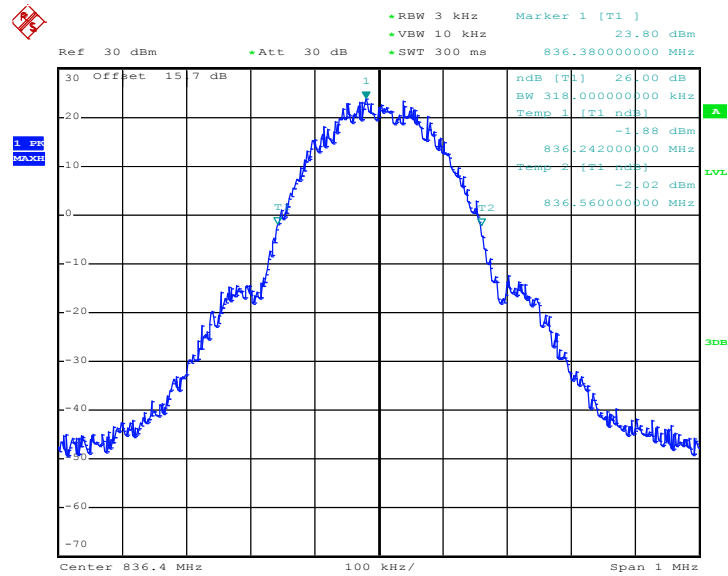

Date: 28.MAR.2012 10:35:47



99% Occupied Bandwidth Plot on Channel 251

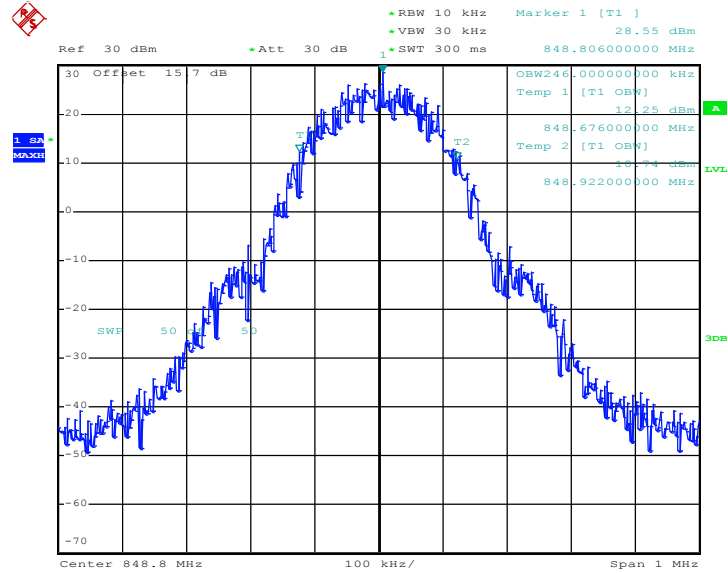

Date: 28.MAR.2012 10:38:31

26dB Bandwidth Plot on Channel 251

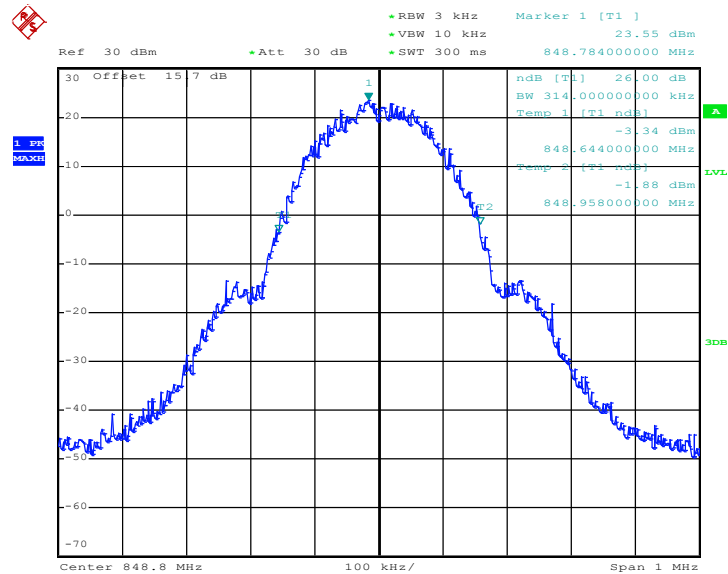

Date: 28.MAR.2012 10:36:13



Band :	GSM 850	Power Stage :	High
Test Mode :	EDGE 8 Link		

99% Occupied Bandwidth Plot on Channel 128

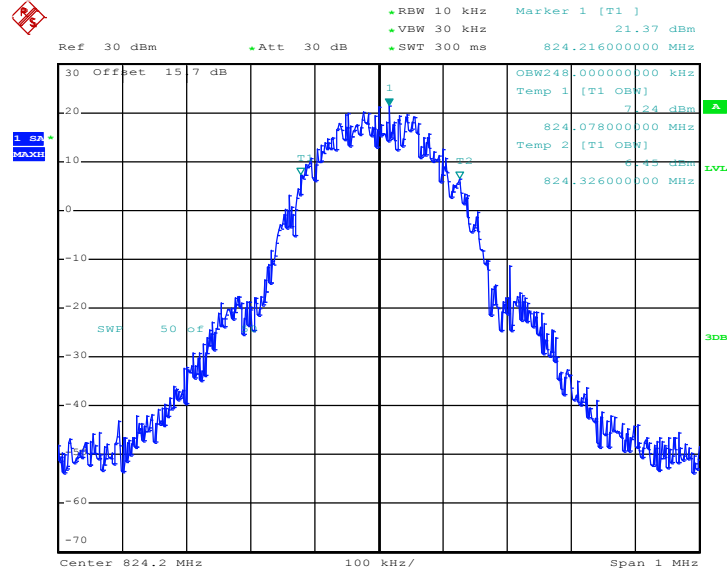

Date: 28.MAR.2012 11:04:20

26dB Bandwidth Plot on Channel 128

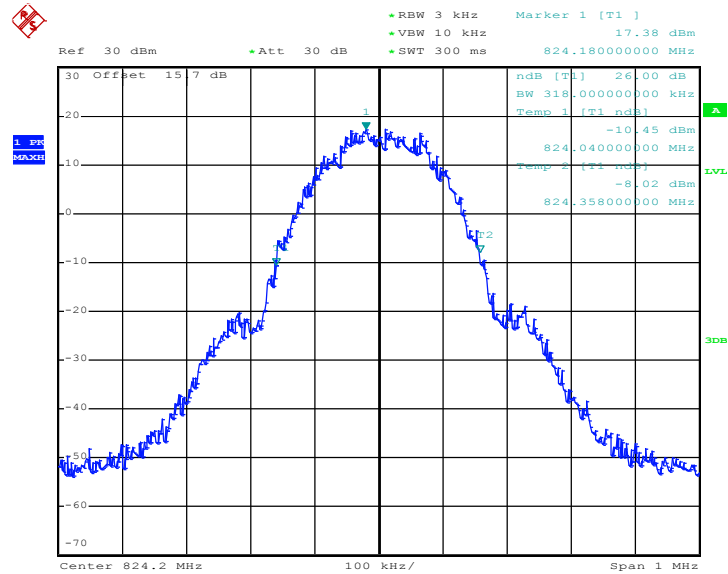

Date: 28.MAR.2012 11:01:49



99% Occupied Bandwidth Plot on Channel 189

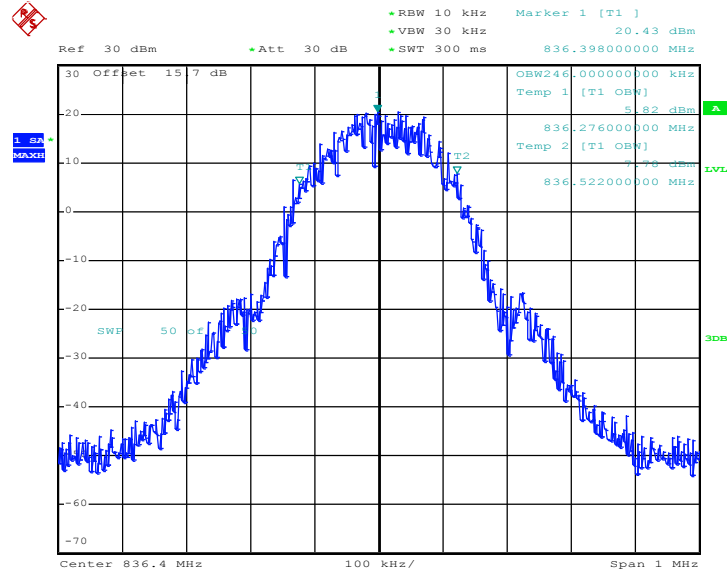

Date: 28.MAR.2012 11:04:39

26dB Bandwidth Plot on Channel 189

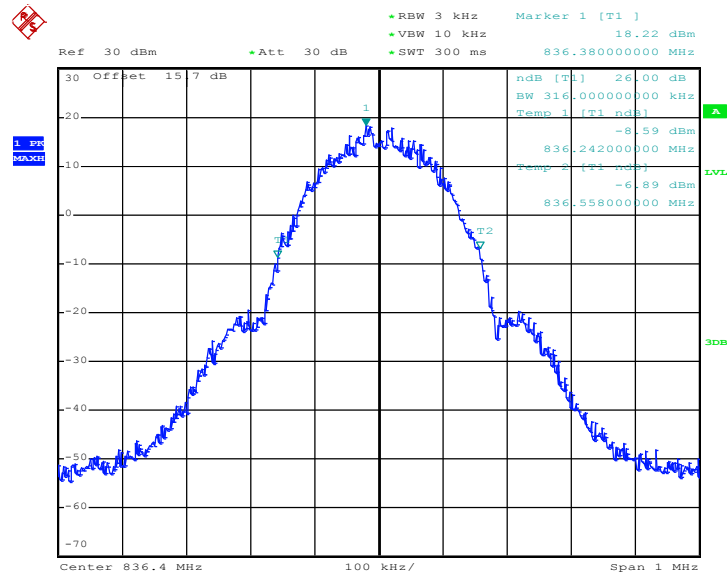

Date: 28.MAR.2012 11:02:15



99% Occupied Bandwidth Plot on Channel 251

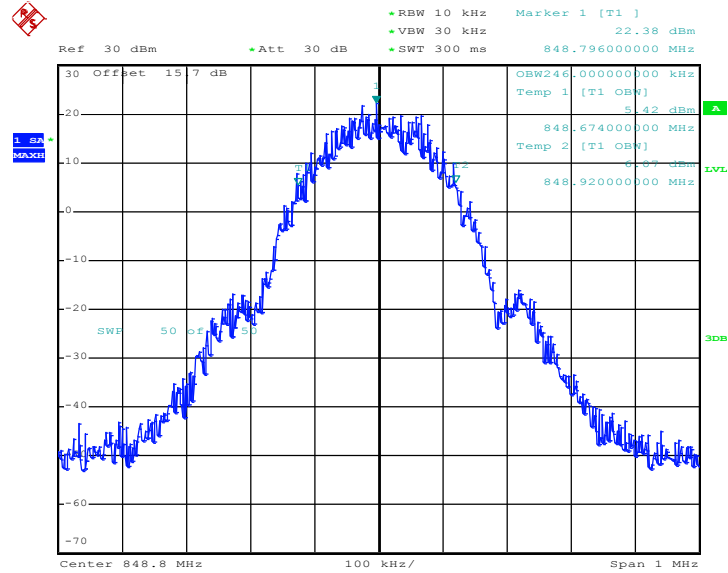

Date: 28.MAR.2012 11:04:59

26dB Bandwidth Plot on Channel 251

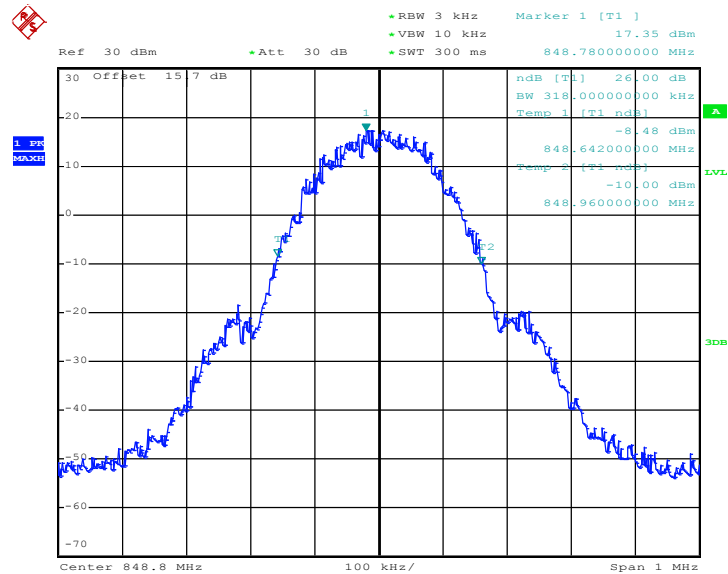

Date: 28.MAR.2012 11:02:41



Band :	GSM 1900	Power Stage :	High
Test Mode :	GPRS 8 Link		

99% Occupied Bandwidth Plot on Channel 512

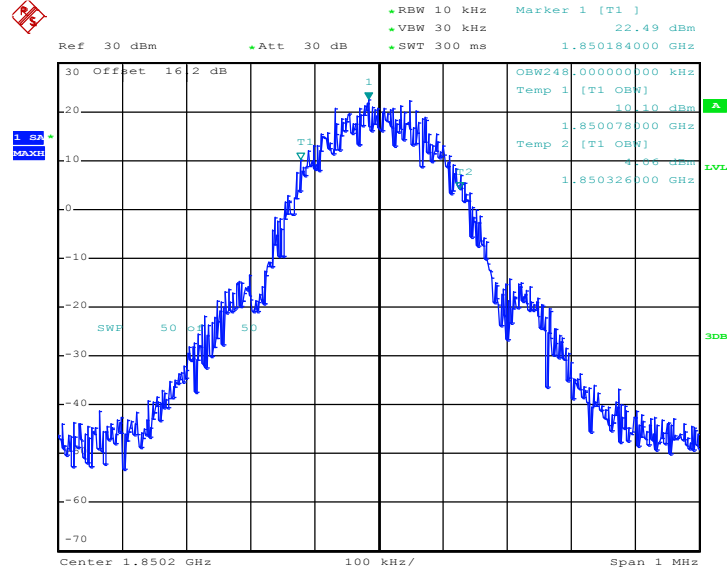

Date: 30.MAR.2012 08:54:59

26dB Bandwidth Plot on Channel 512

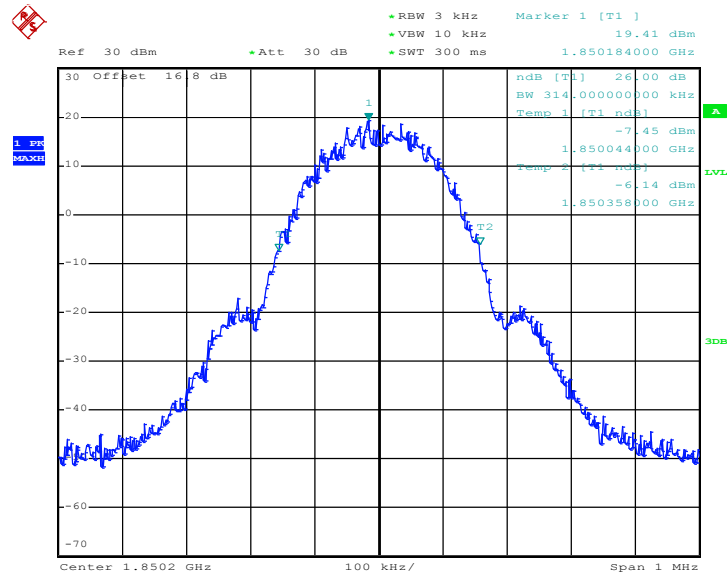

Date: 28.MAR.2012 12:01:21



99% Occupied Bandwidth Plot on Channel 661

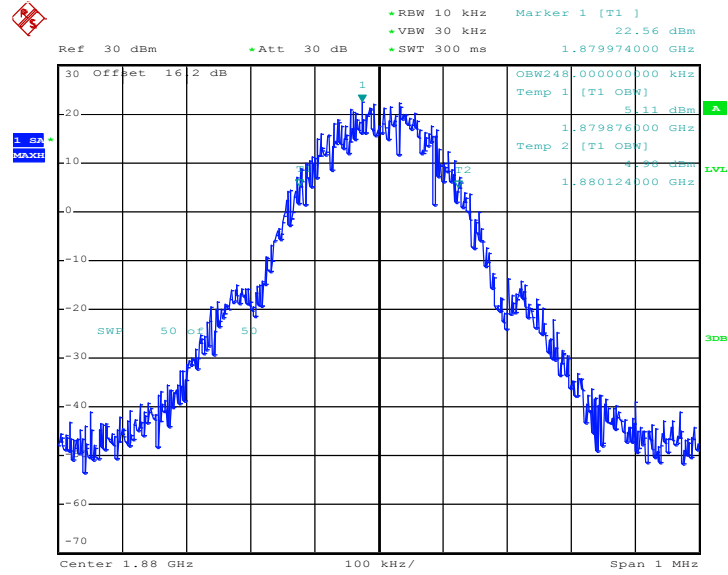

Date: 30.MAR.2012 08:55:18

26dB Bandwidth Plot on Channel 661

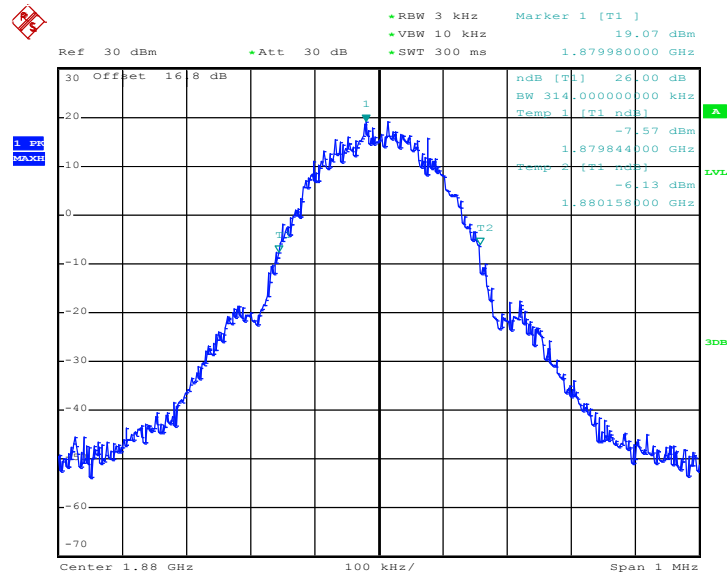

Date: 28.MAR.2012 12:01:48



99% Occupied Bandwidth Plot on Channel 810

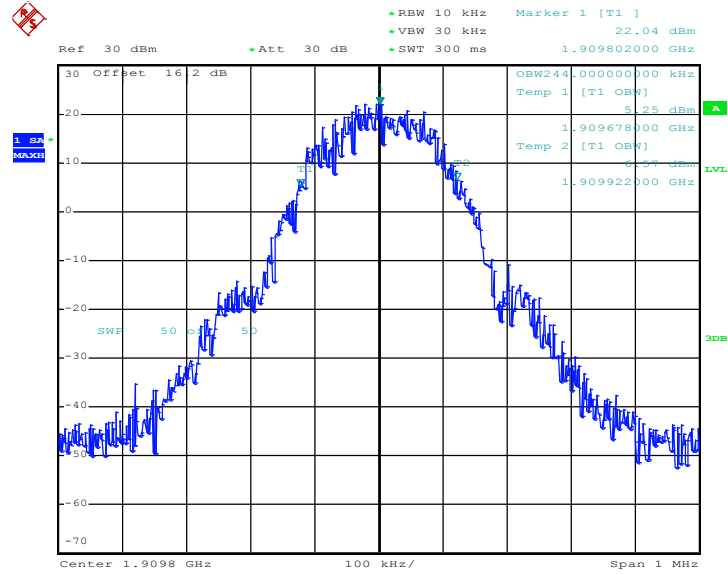

Date: 30.MAR.2012 08:55:38

26dB Bandwidth Plot on Channel 810

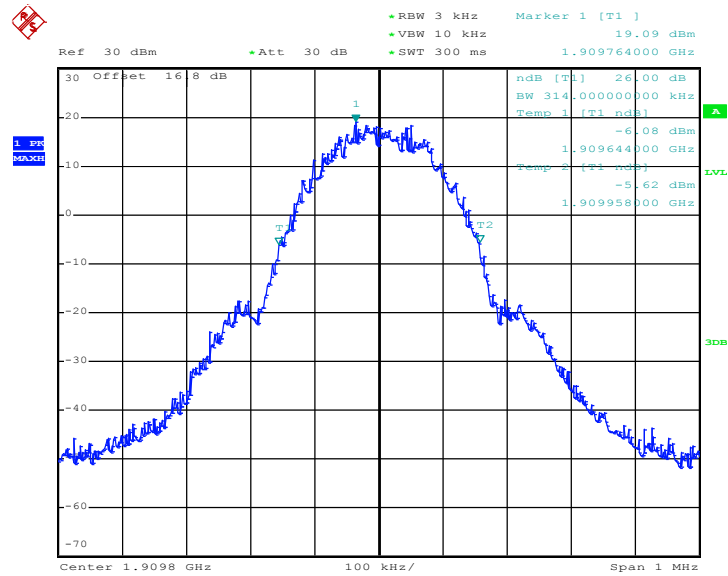

Date: 28.MAR.2012 12:02:14



Band :	GSM 1900	Power Stage :	High
Test Mode :	EDGE 8 Link		

99% Occupied Bandwidth Plot on Channel 512

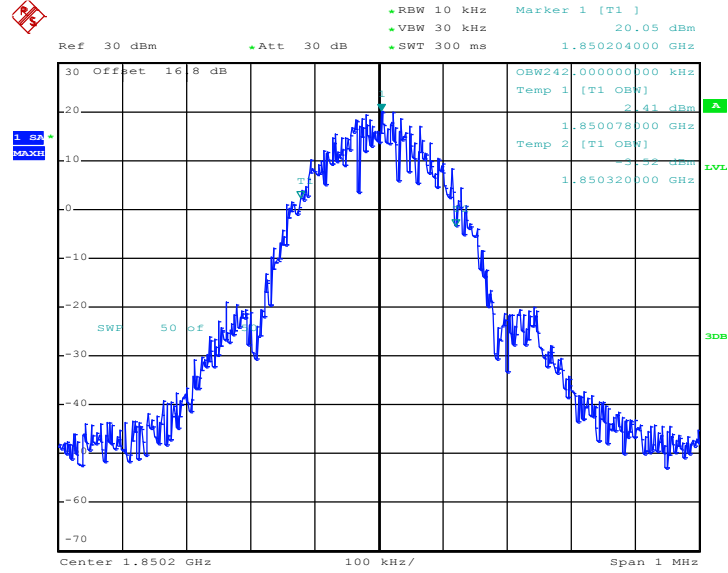

Date: 28.MAR.2012 13:51:53

26dB Bandwidth Plot on Channel 512

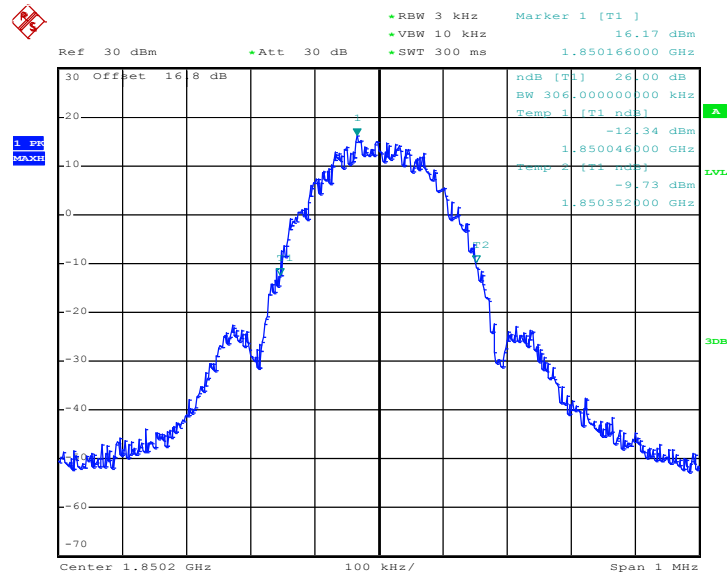

Date: 28.MAR.2012 13:49:21



99% Occupied Bandwidth Plot on Channel 661

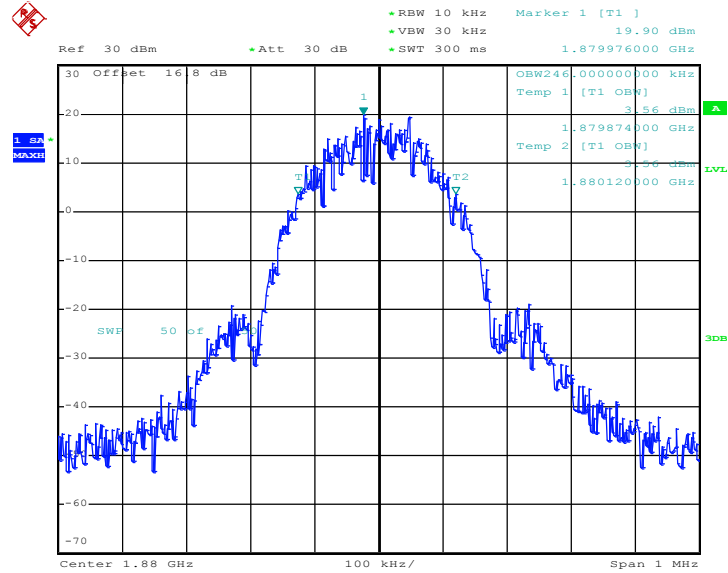

Date: 28.MAR.2012 13:52:12

26dB Bandwidth Plot on Channel 661

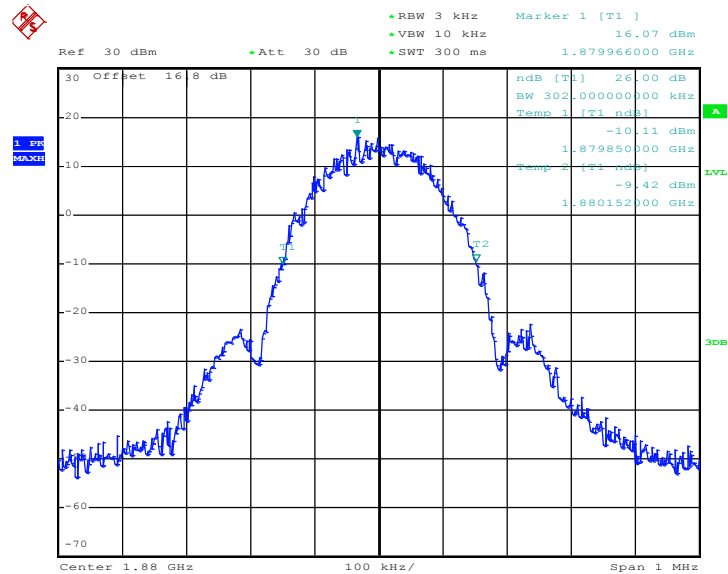

Date: 28.MAR.2012 13:49:48



99% Occupied Bandwidth Plot on Channel 810

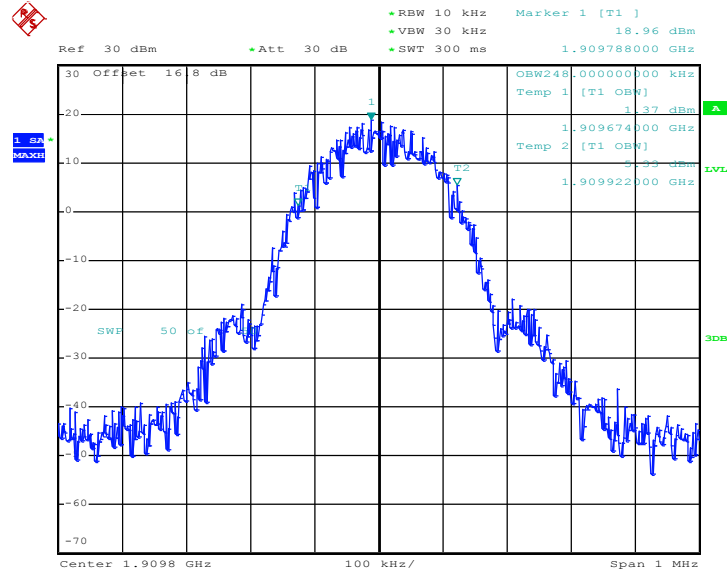

Date: 28.MAR.2012 13:52:32

26dB Bandwidth Plot on Channel 810

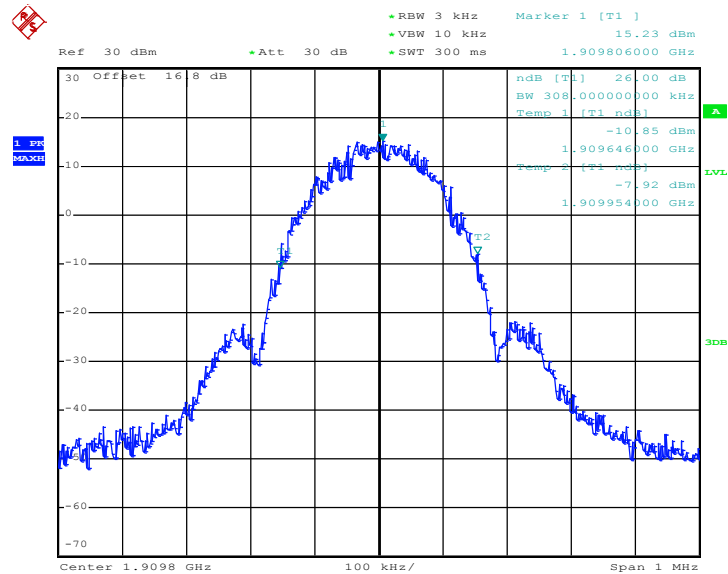

Date: 28.MAR.2012 13:50:14



Band :	WCDMA Band V	Power Stage :	High
Test Mode :	RMC 12.2Kbps Link		

99% Occupied Bandwidth Plot on Channel 4132

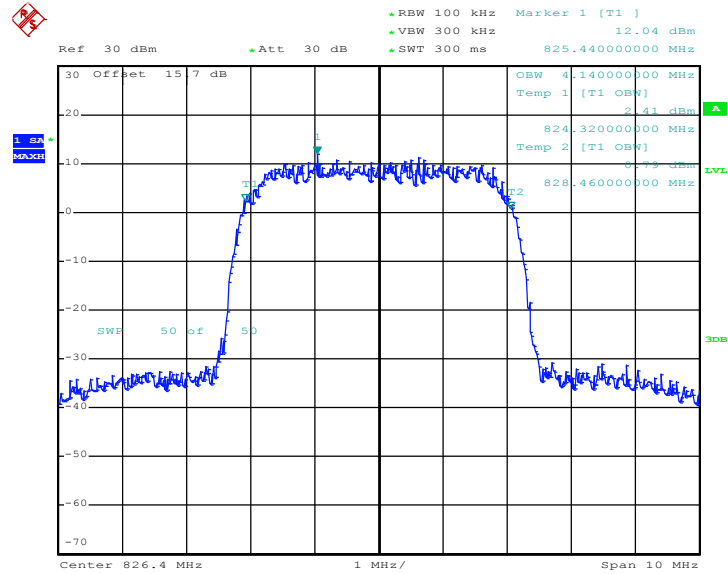

Date: 28.MAR.2012 15:48:07

26dB Bandwidth Plot on Channel 4132

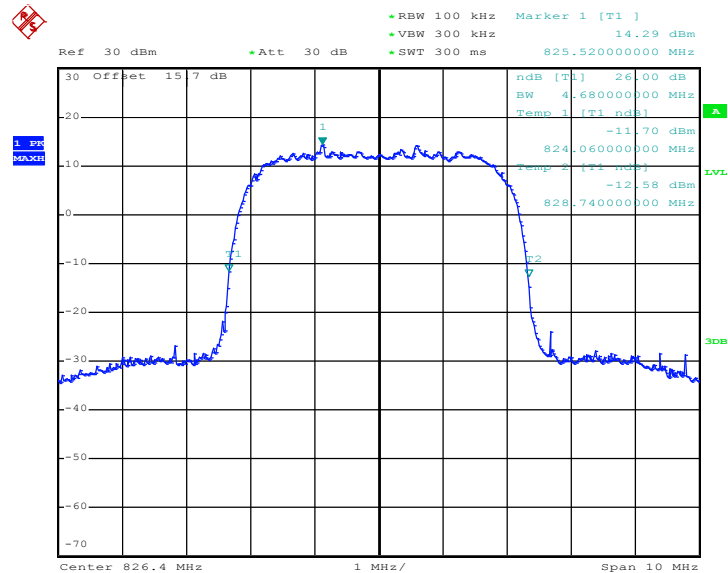

Date: 28.MAR.2012 15:45:35



99% Occupied Bandwidth Plot on Channel 4182

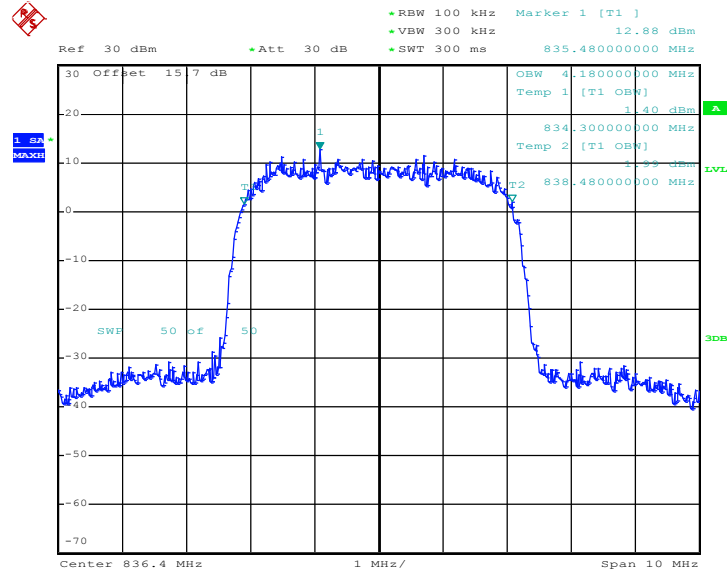

Date: 28.MAR.2012 15:48:27

26dB Bandwidth Plot on Channel 4182

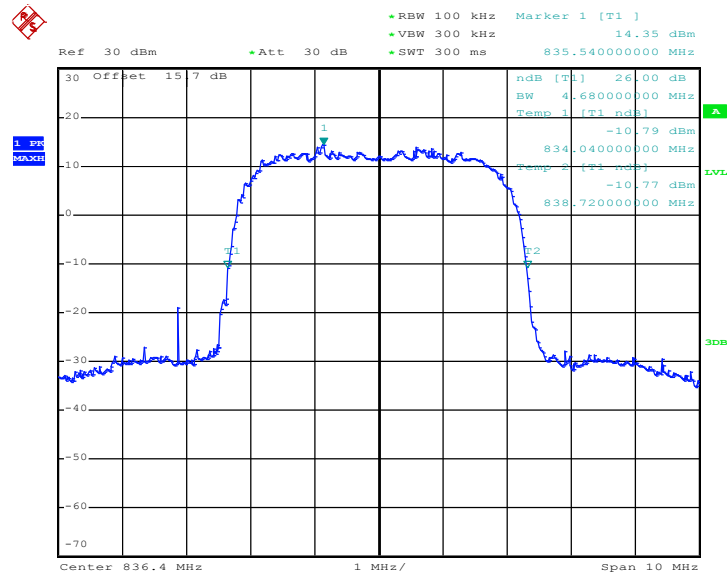

Date: 28.MAR.2012 15:46:01



99% Occupied Bandwidth Plot on Channel 4233

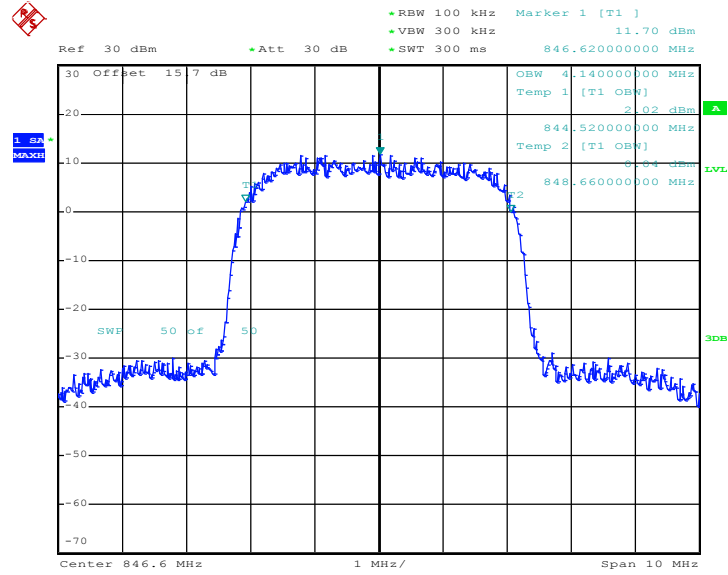

Date: 28.MAR.2012 15:48:48

26dB Bandwidth Plot on Channel 4233

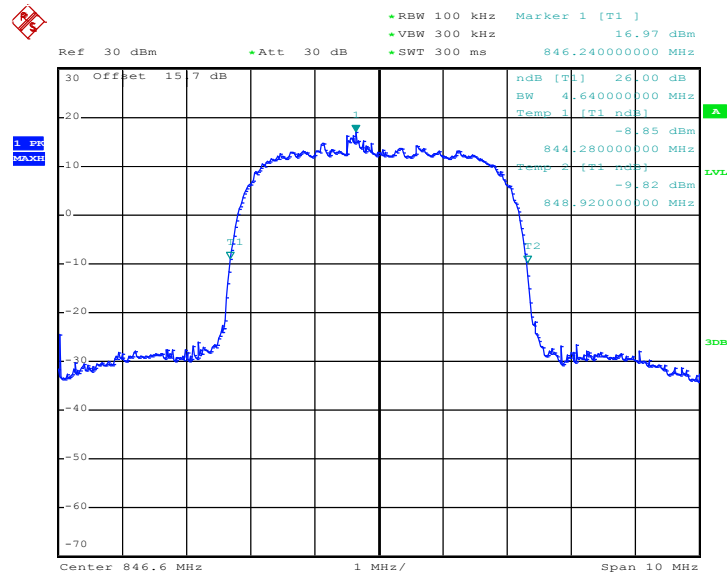

Date: 28.MAR.2012 15:46:28



Band :	WCDMA Band IV	Power Stage :	High
Test Mode :	RMC 12.2Kbps Link		

99% Occupied Bandwidth Plot on Channel 1312

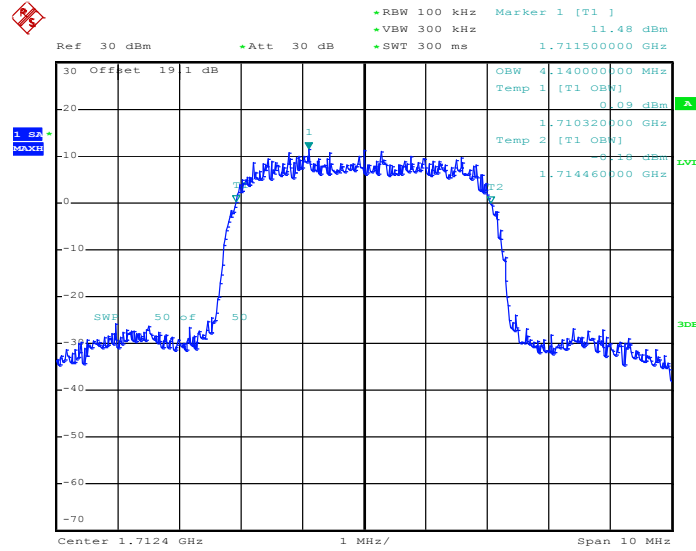

Date: 28.MAR.2012 17:24:03

26dB Bandwidth Plot on Channel 1312

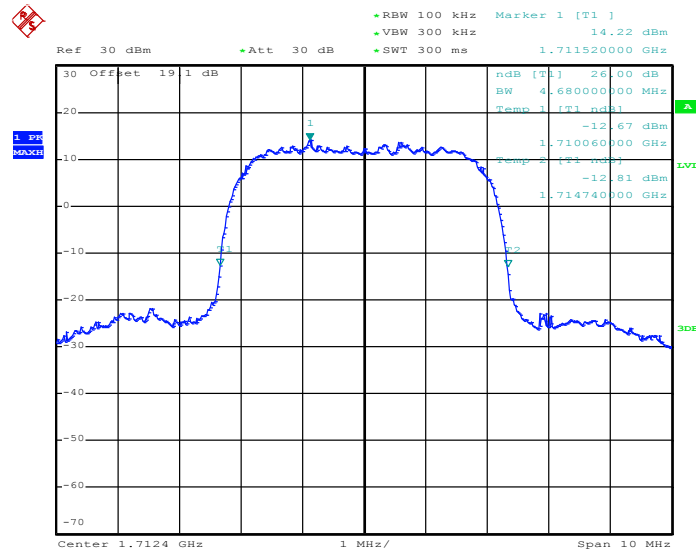

Date: 28.MAR.2012 17:21:31



99% Occupied Bandwidth Plot on Channel 1413

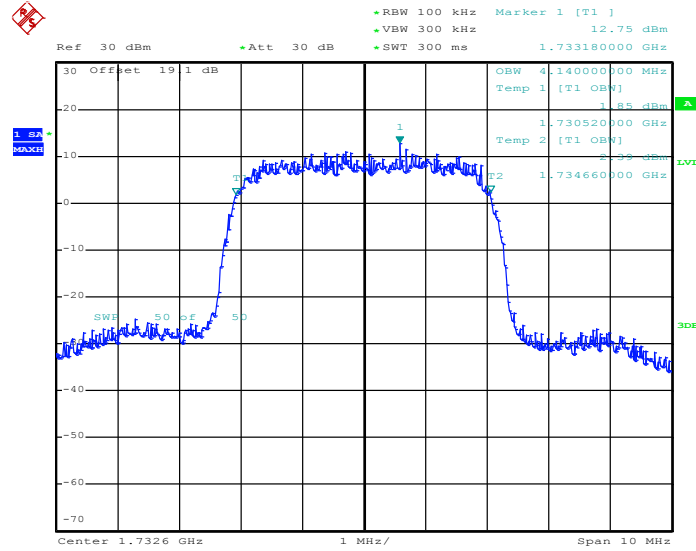

Date: 28.MAR.2012 17:24:23

26dB Bandwidth Plot on Channel 1413

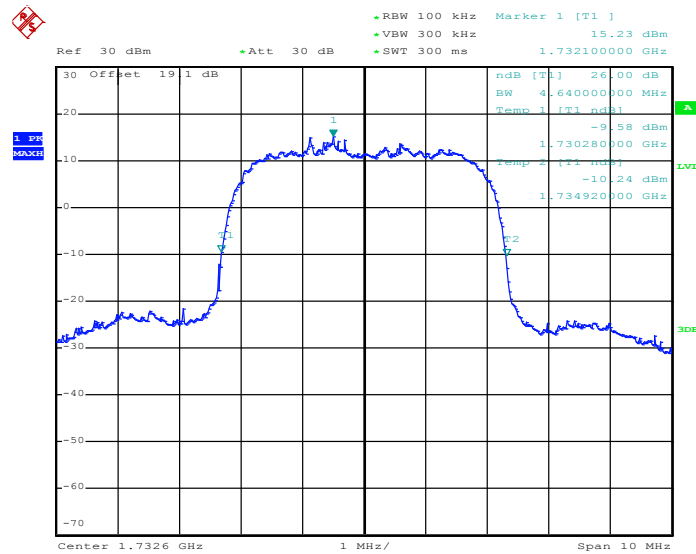

Date: 28.MAR.2012 17:21:57



99% Occupied Bandwidth Plot on Channel 1513

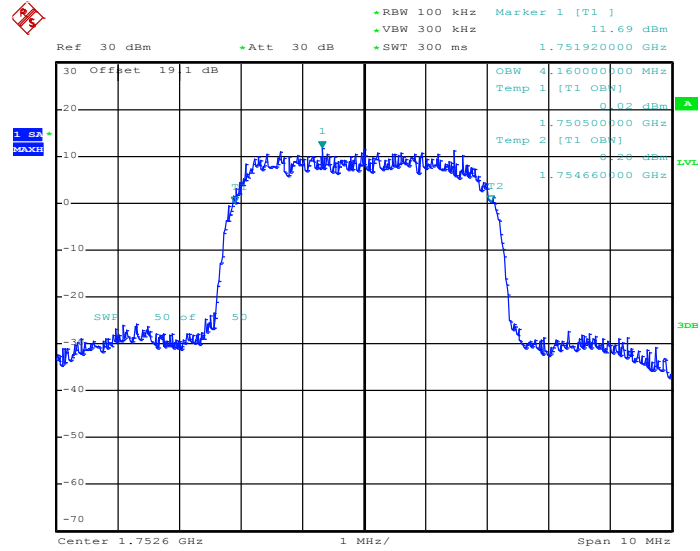

Date: 28.MAR.2012 17:24:43

26dB Bandwidth Plot on Channel 1513

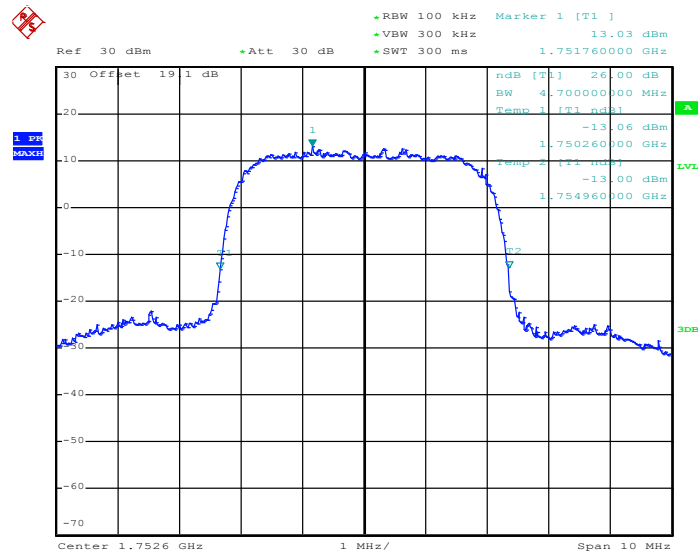

Date: 28.MAR.2012 17:22:24



Band :	WCDMA Band II	Power Stage :	High
Test Mode :	RMC 12.2Kbps Link		

99% Occupied Bandwidth Plot on Channel 9262

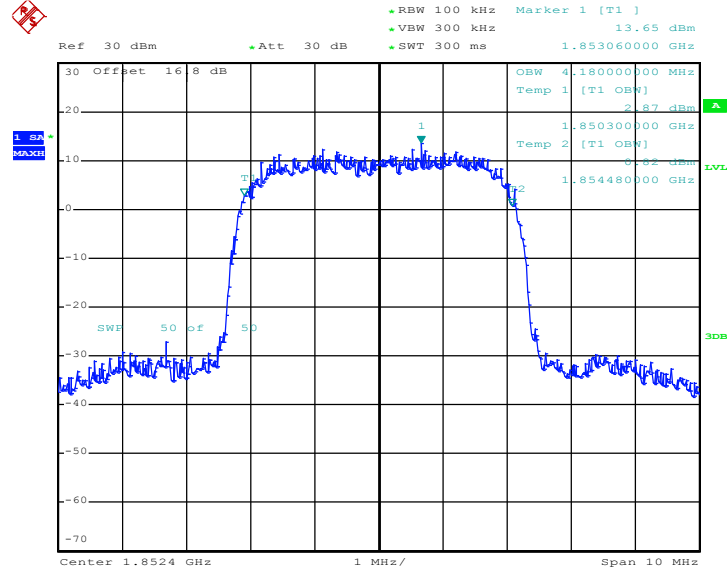

Date: 28.MAR.2012 16:15:36

26dB Bandwidth Plot on Channel 9262

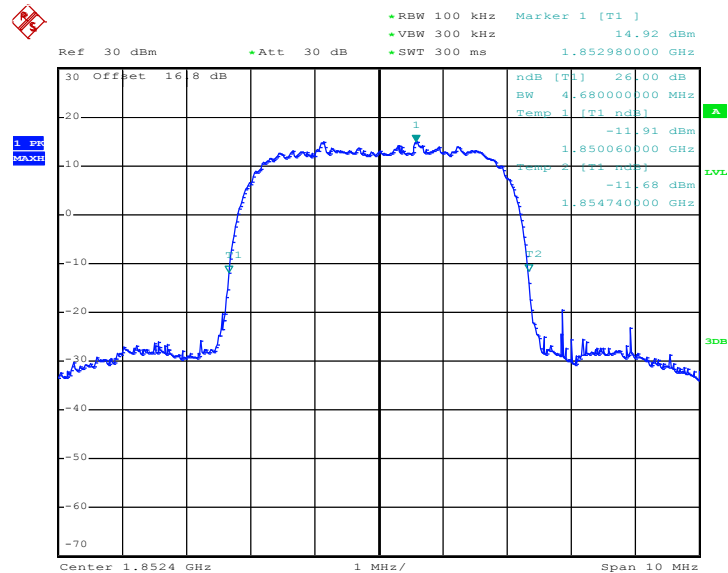

Date: 28.MAR.2012 16:13:04



99% Occupied Bandwidth Plot on Channel 9400

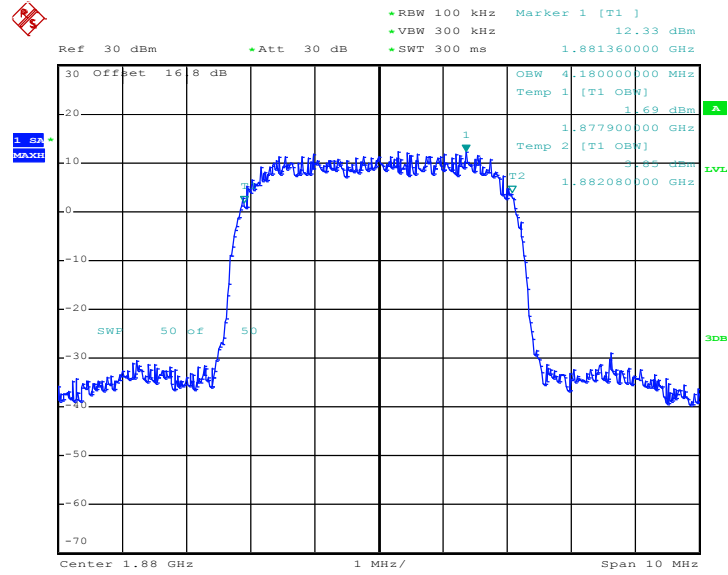

Date: 28.MAR.2012 16:15:56

26dB Bandwidth Plot on Channel 9400

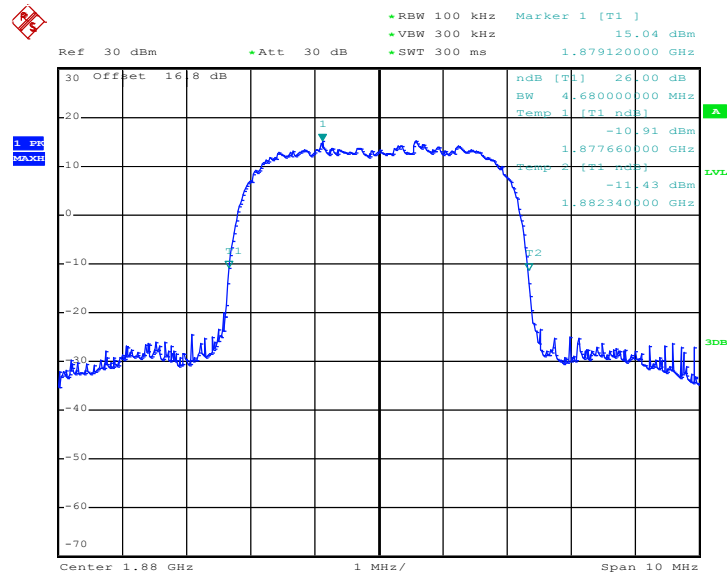

Date: 28.MAR.2012 16:13:30



99% Occupied Bandwidth Plot on Channel 9538

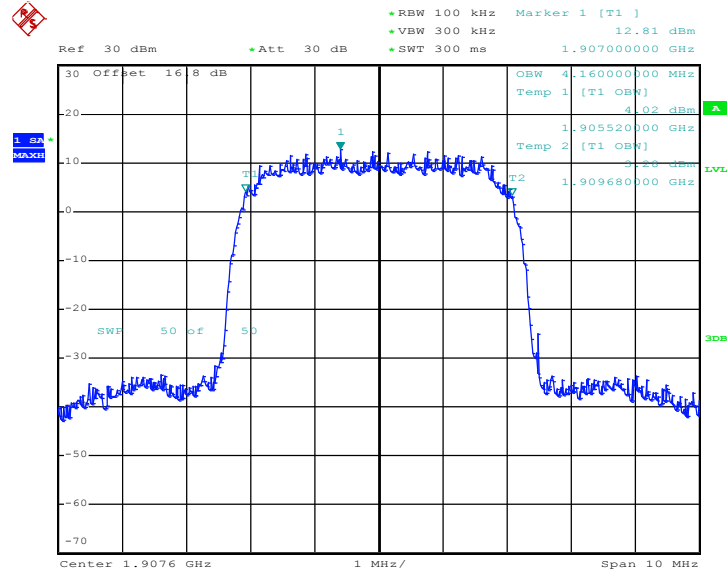

Date: 28.MAR.2012 16:16:17

26dB Bandwidth Plot on Channel 9538

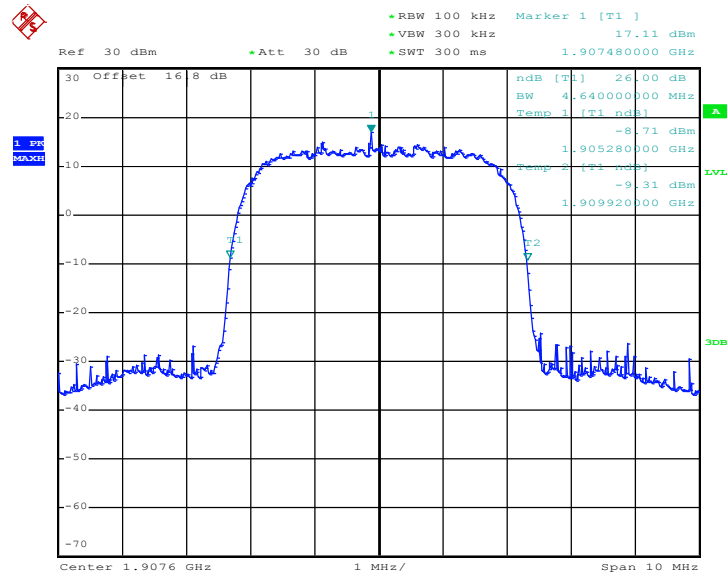

Date: 28.MAR.2012 16:13:57

3.4 Band Edge Measurement

3.4.1 Description of Band Edge Measurement

The power of any emission outside of the authorized operating frequency ranges must be lower than the transmitter power (P) by a factor of at least $43 + 10 \log (P)$ dB.

3.4.2 Measuring Instruments

See list of measuring instruments of this test report.

3.4.3 Test Procedures

1. The EUT was connected to Spectrum Analyzer and Base Station via power divider.
2. The band edges of low and high channels for the highest RF powers were measured. Setting RBW as roughly BW/100.

3.4.4 Test Setup

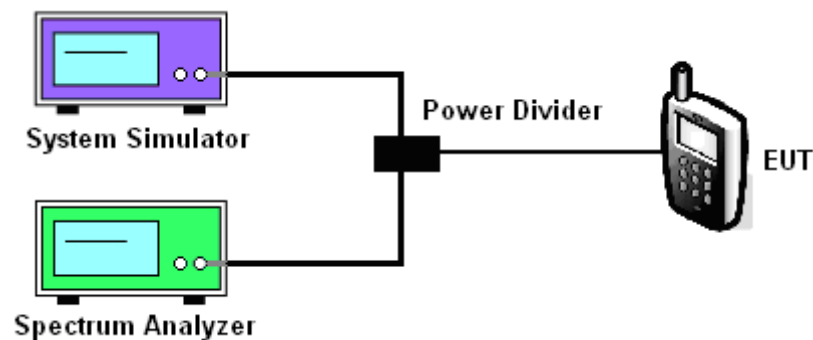



3.4.5 Test Result (Plots) of Conducted Band Edge

Band :	GSM850	Power Stage :	High
Test Mode :	GPRS 8 Link	Maximum 26dB Bandwidth :	0.318MHz
Correction Factor :	0.25dB	Measurement Value :	-18.14dBm
Band Edge :	-17.89dBm		

Lower Band Edge Plot on Channel 128

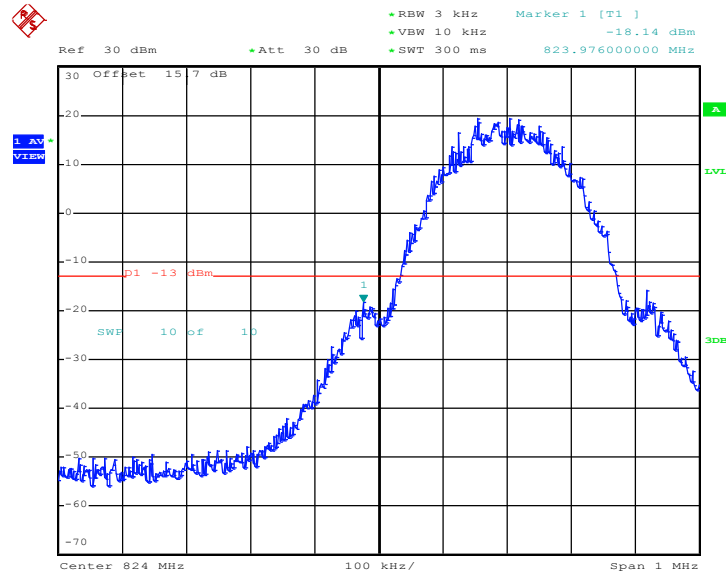

Date: 28.MAR.2012 10:39:54

1. Correction Factor(dB)= 10log(1% Emission BW/RBW)
2. Band Edge= Measurement Value + Correction Factor(dB)



Band :	GSM850	Power Stage :	High
Test Mode :	GPRS 8 Link	Maximum 26dB Bandwidth :	0.318MHz
Correction Factor :	0.25dB	Measurement Value :	-17.48dBm
Band Edge :	-17.23dBm		

Higher Band Edge Plot on Channel 251

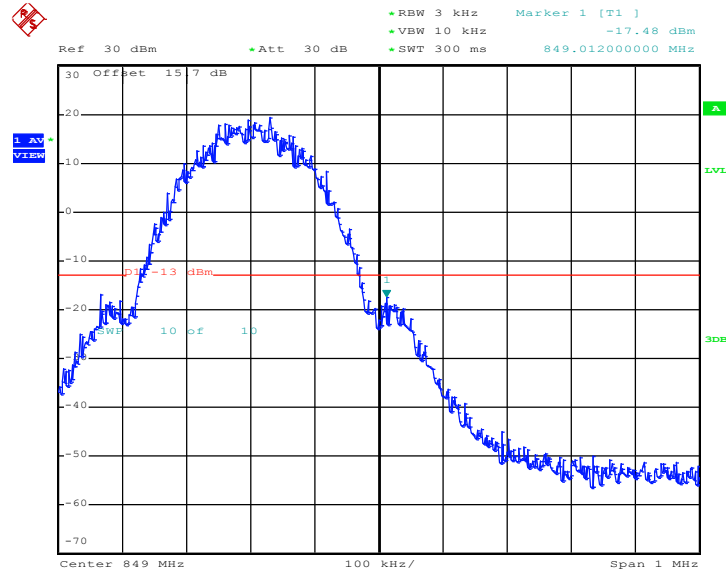

Date: 28.MAR.2012 10:40:24

1. Correction Factor(dB)= $10\log(1\% \text{ Emission BW/RBW})$
2. Band Edge= Measurement Value + Correction Factor(dB)



Band :	GSM850	Power Stage :	High
Test Mode :	EDGE 8 Link	Maximum 26dB Bandwidth :	0.318MHz
Correction Factor :	0.25dB	Measurement Value :	-24.10dBm
Band Edge :	-23.85dBm		

Lower Band Edge Plot on Channel 128

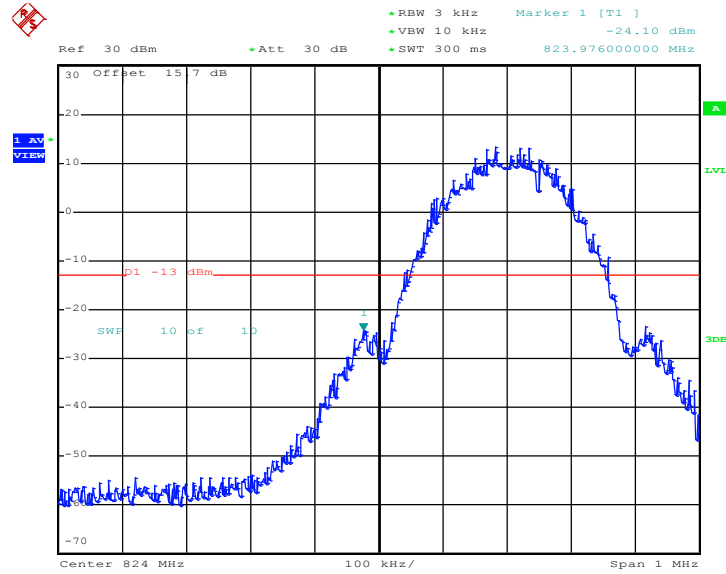

Date: 28.MAR.2012 11:06:22

1. Correction Factor(dB)= $10\log(1\% \text{ Emission BW/RBW})$
2. Band Edge= Measurement Value + Correction Factor(dB)



Band :	GSM850	Power Stage :	High
Test Mode :	EDGE 8 Link	Maximum 26dB Bandwidth :	0.318MHz
Correction Factor :	0.25dB	Measurement Value :	-24.70dBm
Band Edge :	-24.45dBm		

Higher Band Edge Plot on Channel 251

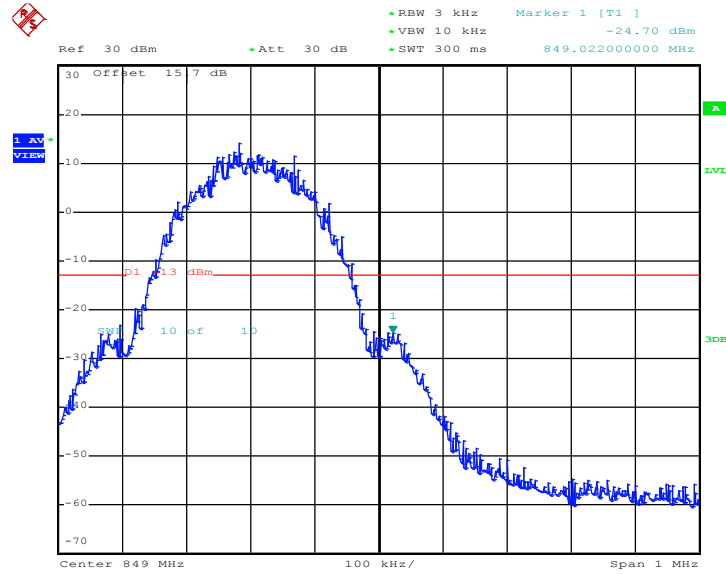

Date: 28.MAR.2012 11:06:52

1. Correction Factor(dB)= $10\log(1\% \text{ Emission BW/RBW})$
2. Band Edge= Measurement Value + Correction Factor(dB)



Band :	GSM1900	Power Stage :	High
Test Mode :	GPRS 8 Link	Maximum 26dB Bandwidth :	0.314MHz
Correction Factor :	0.20dB	Measurement Value :	-23.25dBm
Band Edge :	-23.05dBm		

Lower Band Edge Plot on Channel 512

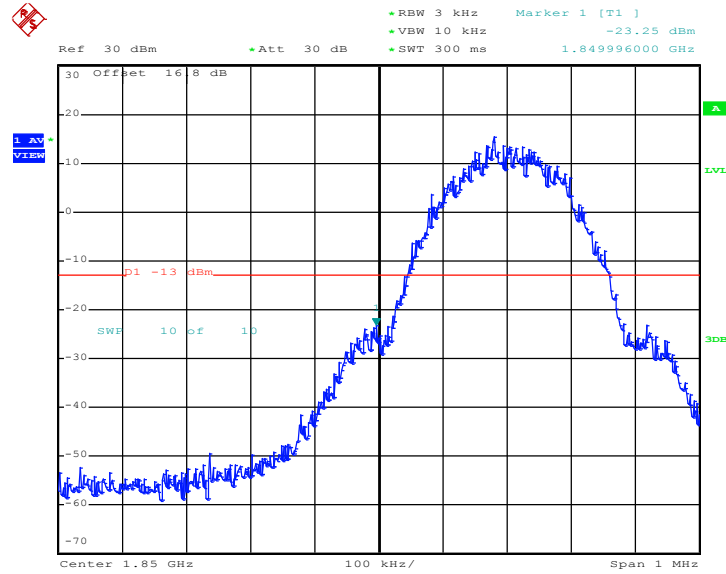

Date: 28.MAR.2012 12:05:55

1. Correction Factor(dB)= $10\log(1\% \text{ Emission BW/RBW})$
2. Band Edge= Measurement Value + Correction Factor(dB)



Band :	GSM1900	Power Stage :	High
Test Mode :	GPRS 8 Link	Maximum 26dB Bandwidth :	0.314MHz
Correction Factor :	0.20dB	Measurement Value :	-22.82dBm
Band Edge :	-22.62dBm		

Higher Band Edge Plot on Channel 810

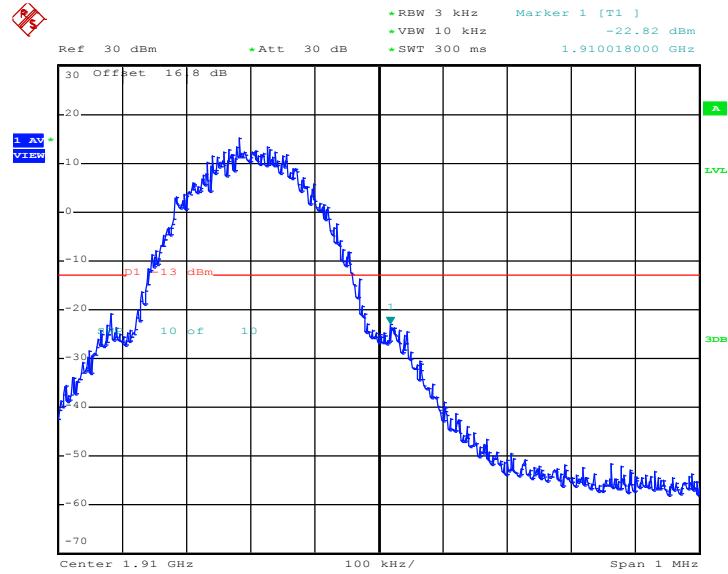

Date: 28.MAR.2012 12:06:24

1. Correction Factor(dB)= $10\log(1\% \text{ Emission BW/RBW})$
2. Band Edge= Measurement Value + Correction Factor(dB)



Band :	GSM1900	Power Stage :	High
Test Mode :	EDGE 8 Link	Maximum 26dB Bandwidth :	0.308MHz
Correction Factor :	0.11dB	Measurement Value :	-26.65dBm
Band Edge :	-26.54dBm		

Lower Band Edge Plot on Channel 512

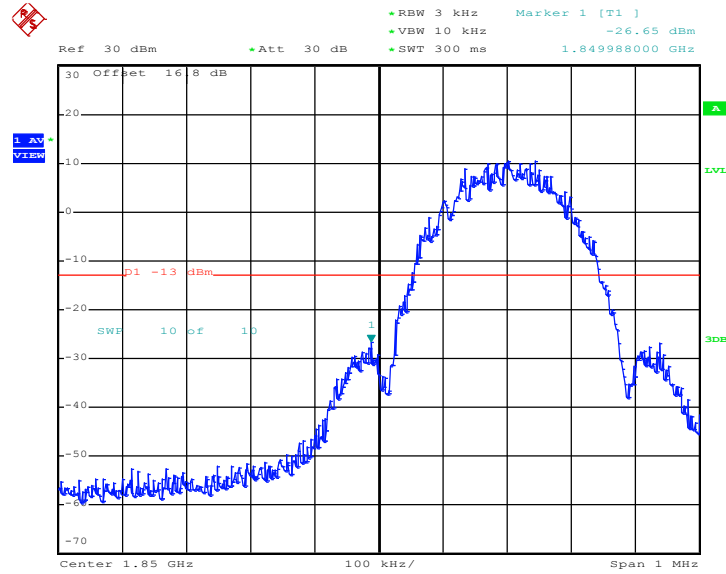

Date: 28.MAR.2012 13:53:55

1. Correction Factor(dB)= 10log(1% Emission BW/RBW)
2. Band Edge= Measurement Value + Correction Factor(dB)



Band :	GSM1900	Power Stage :	High
Test Mode :	EDGE 8 Link	Maximum 26dB Bandwidth :	0.308MHz
Correction Factor :	0.11dB	Measurement Value :	-26.73dBm
Band Edge :	-26.62dBm		

Higher Band Edge Plot on Channel 810

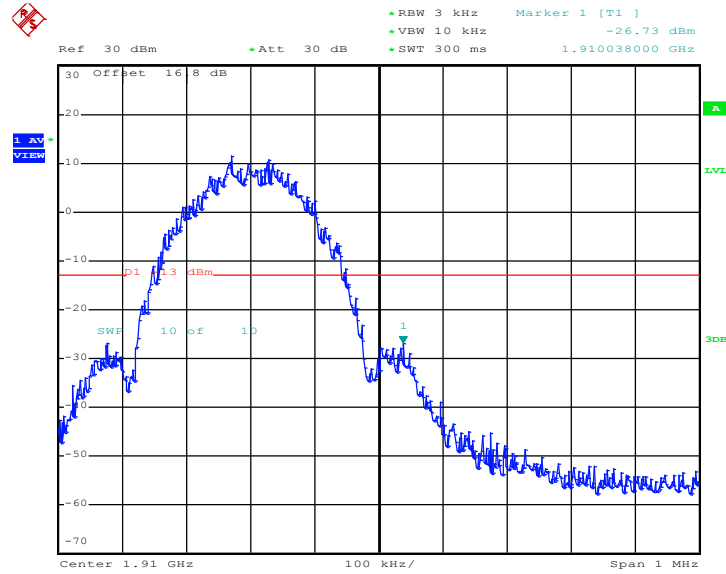

Date: 28.MAR.2012 13:54:24

1. Correction Factor(dB)= 10log(1% Emission BW/RBW)
2. Band Edge= Measurement Value + Correction Factor(dB)



Band :	WCDMA Band V	Power Stage :	High
Test Mode :	RMC 12.2Kbps Link	Maximum 26dB Bandwidth :	4.68MHz
Correction Factor :	-3.30dB	Measurement Value :	-32.27dBm
Band Edge :	-35.57dBm		

Lower Band Edge Plot on Channel 4132

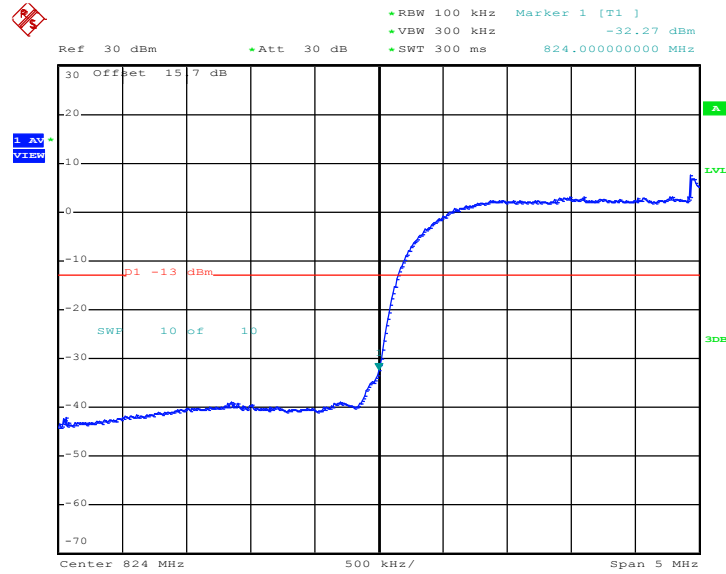

Date: 28.MAR.2012 15:50:11

1. Correction Factor(dB)= $10\log(1\% \text{ Emission BW/RBW})$
2. Band Edge= Measurement Value + Correction Factor(dB)



Band :	WCDMA Band V	Power Stage :	High
Test Mode :	RMC 12.2Kbps Link	Maximum 26dB Bandwidth :	4.68MHz
Correction Factor :	-3.30dB	Measurement Value :	-31.78dBm
Band Edge :	-35.08dBm		

Higher Band Edge Plot on Channel 4233

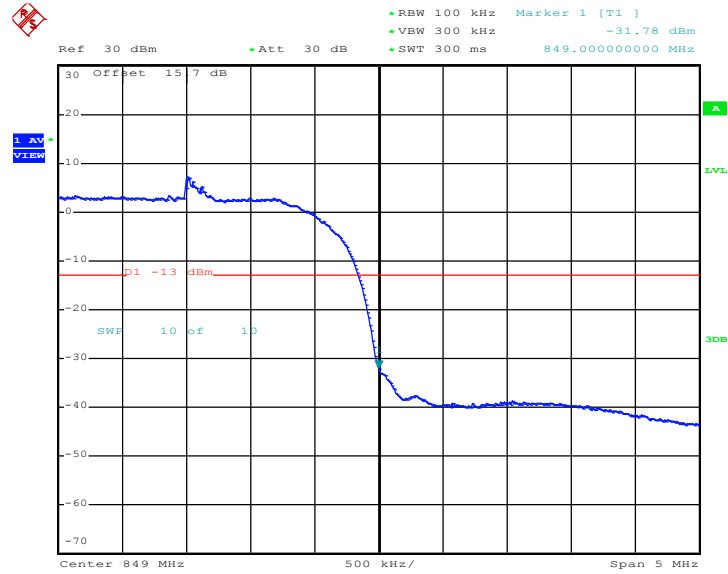

Date: 28.MAR.2012 15:50:40

1. Correction Factor(dB)= 10log(1% Emission BW/RBW)
2. Band Edge= Measurement Value + Correction Factor(dB)



Band :	WCDMA Band IV	Power Stage :	High
Test Mode :	RMC 12.2Kbps Link	Maximum 26dB Bandwidth :	4.70MHz
Correction Factor :	-3.28dB	Measurement Value :	-29.13dBm
Band Edge :	-32.41dBm		

Lower Band Edge Plot on Channel 1312

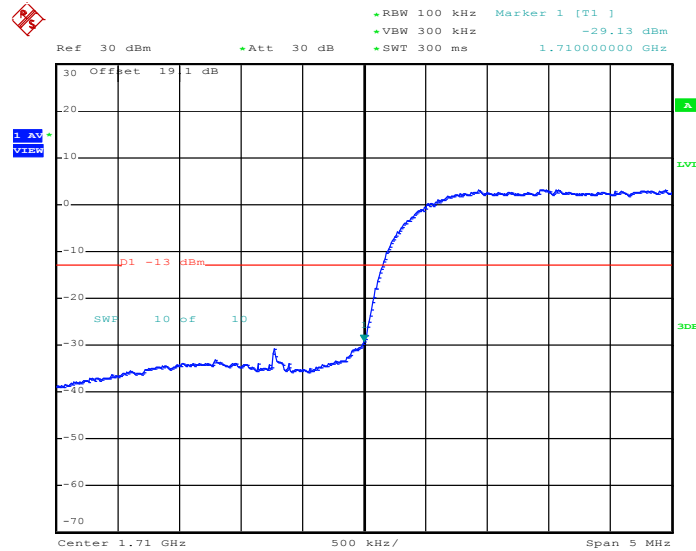

Date: 28.MAR.2012 17:26:06

1. Correction Factor(dB)= $10\log(1\% \text{ Emission BW/RBW})$
2. Band Edge= Measurement Value + Correction Factor(dB)



Band :	WCDMA Band IV	Power Stage :	High
Test Mode :	RMC 12.2Kbps Link	Maximum 26dB Bandwidth :	4.70MHz
Correction Factor :	-3.28dB	Measurement Value :	-32.05dBm
Band Edge :	-35.33dBm		

Higher Band Edge Plot on Channel 1513

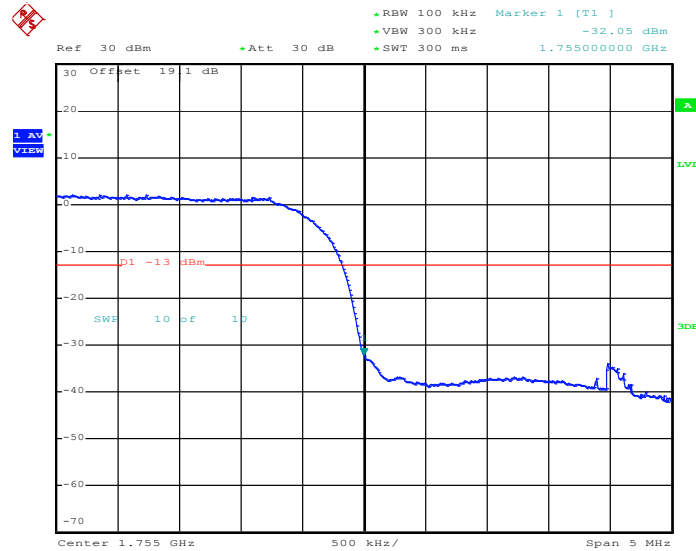

Date: 28.MAR.2012 17:26:36

1. Correction Factor(dB)= $10\log(1\% \text{ Emission BW/RBW})$
2. Band Edge= Measurement Value + Correction Factor(dB)



Band :	WCDMA Band II	Power Stage :	High
Test Mode :	RMC 12.2Kbps Link	Maximum 26dB Bandwidth :	4.68MHz
Correction Factor :	-3.30dB	Measurement Value :	-30.88dBm
Band Edge :	-34.18dBm		

Lower Band Edge Plot on Channel 9262

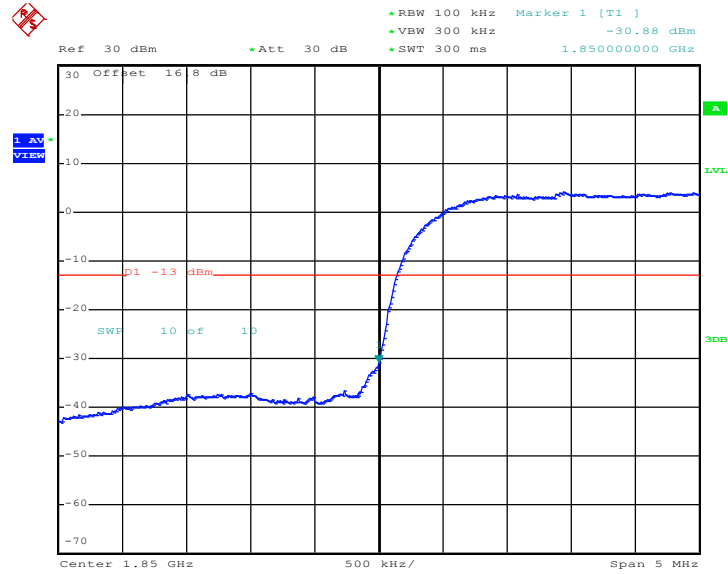

Date: 28.MAR.2012 16:17:40

1. Correction Factor(dB)= $10\log(1\% \text{ Emission BW/RBW})$
2. Band Edge= Measurement Value + Correction Factor(dB)



Band :	WCDMA Band II	Power Stage :	High
Test Mode :	RMC 12.2Kbps Link	Maximum 26dB Bandwidth :	4.68MHz
Correction Factor :	-3.30dB	Measurement Value :	-32.21dBm
Band Edge :	-35.51dBm		

Higher Band Edge Plot on Channel 9538

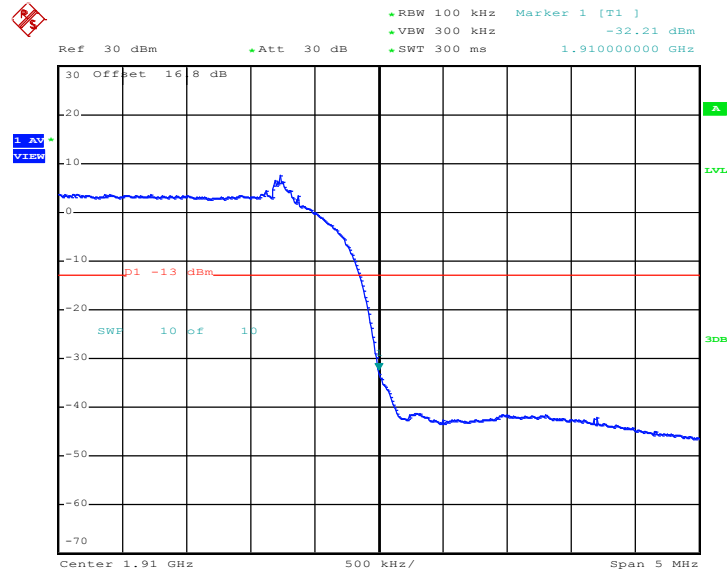

Date: 28.MAR.2012 16:18:09

1. Correction Factor(dB)= $10\log(1\% \text{ Emission BW/RBW})$
2. Band Edge= Measurement Value + Correction Factor(dB)

3.5 Conducted Emission Measurement

3.5.1 Description of Conducted Emission Measurement

The power of any emission outside of the authorized operating frequency ranges must be lower than the transmitter power (P) by a factor of at least $43 + 10 \log (P)$ dB.

It is measured by means of a calibrated spectrum analyzer and scanned from 30 MHz up to a frequency including its 10th harmonic.

3.5.2 Measuring Instruments

See list of measuring instruments of this test report.

3.5.3 Test Procedures

1. The EUT was connected to spectrum analyzer and base station via power divider.
2. The middle channel for the highest RF power within the transmitting frequency was measured.
3. The conducted spurious emission for the whole frequency range was taken.

3.5.4 Test Setup

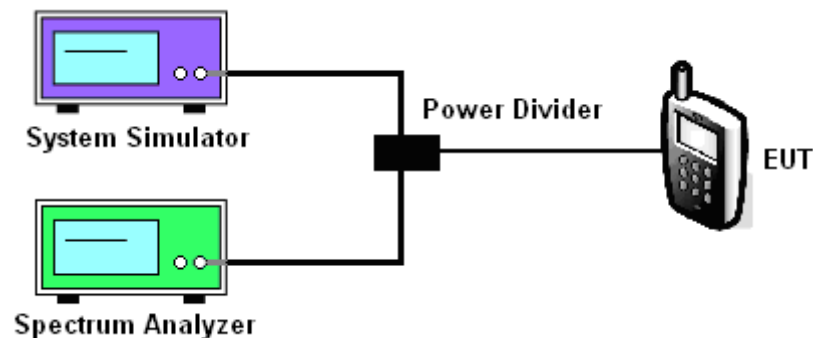



3.5.5 Test Result (Plots) of Conducted Emission

Band :	GSM850	Channel :	CH189
Test Mode :	GPRS 8 Link		

Conducted Emission Plot between 30MHz ~ 1GHz

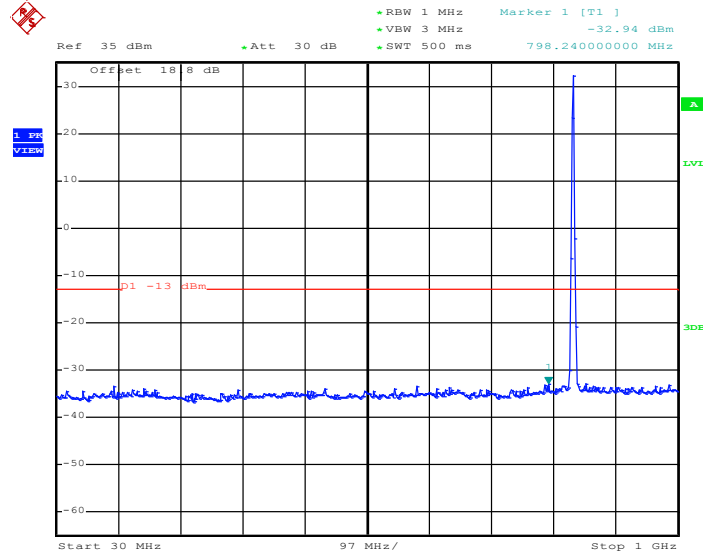

Date: 28.MAR.2012 17:02:53

Conducted Emission Plot between 1GHz ~ 3GHz

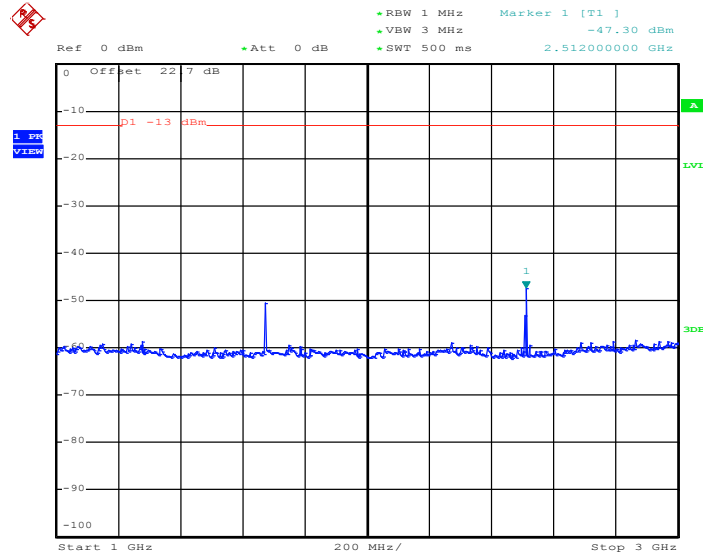

Date: 28.MAR.2012 17:03:18



Conducted Emission Plot between 3GHz ~ 7GHz

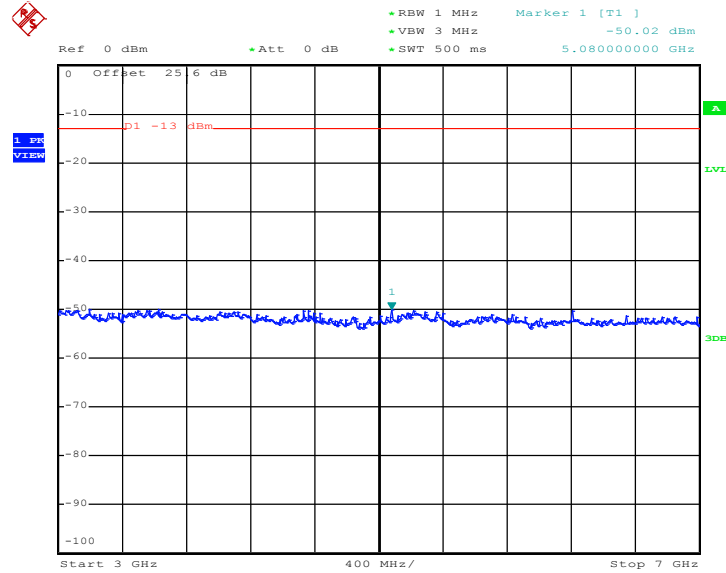

Date: 28.MAR.2012 17:03:30

Conducted Emission Plot between 7GHz ~ 9GHz

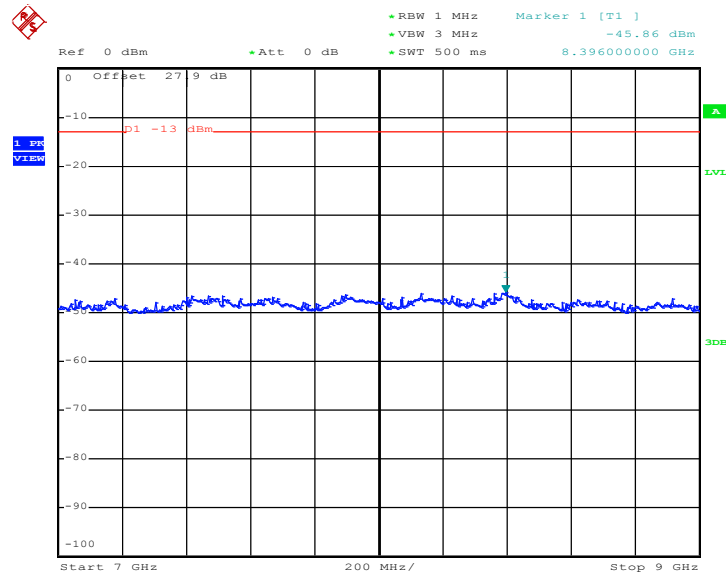

Date: 28.MAR.2012 17:03:43



Band :	GSM850	Channel :	CH189
Test Mode :	EDGE 8 Link		

Conducted Emission Plot between 30MHz ~ 1GHz

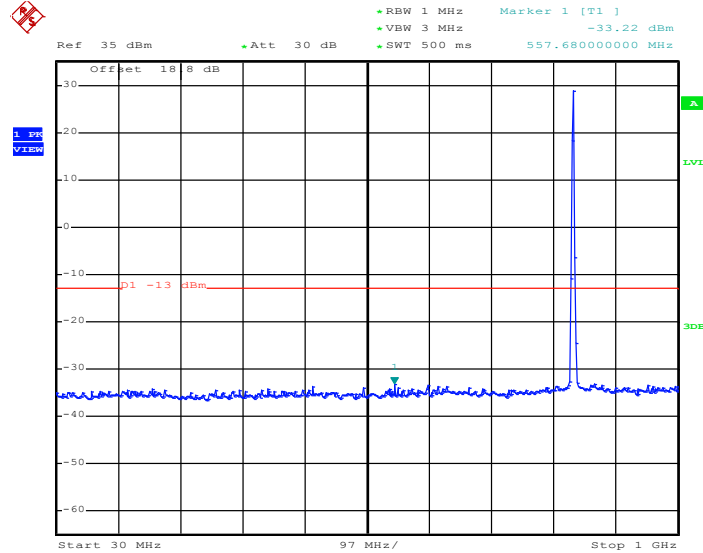

Date: 28.MAR.2012 17:06:20

Conducted Emission Plot between 1GHz ~ 3GHz

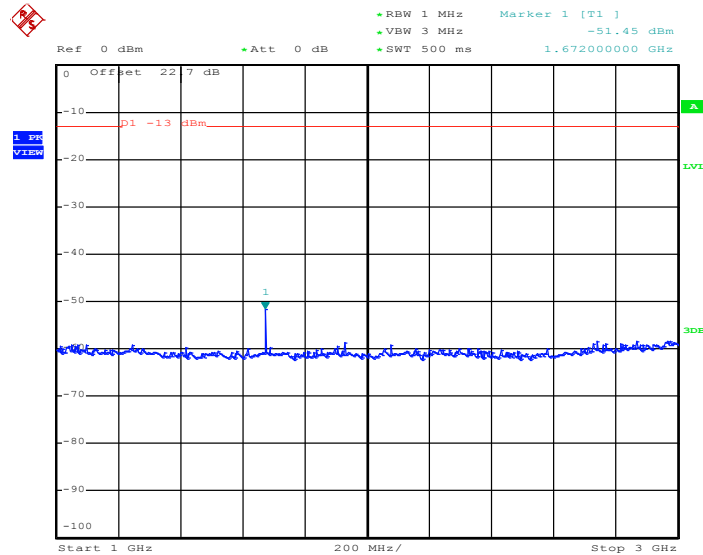

Date: 28.MAR.2012 17:06:38



Conducted Emission Plot between 3GHz ~ 7GHz

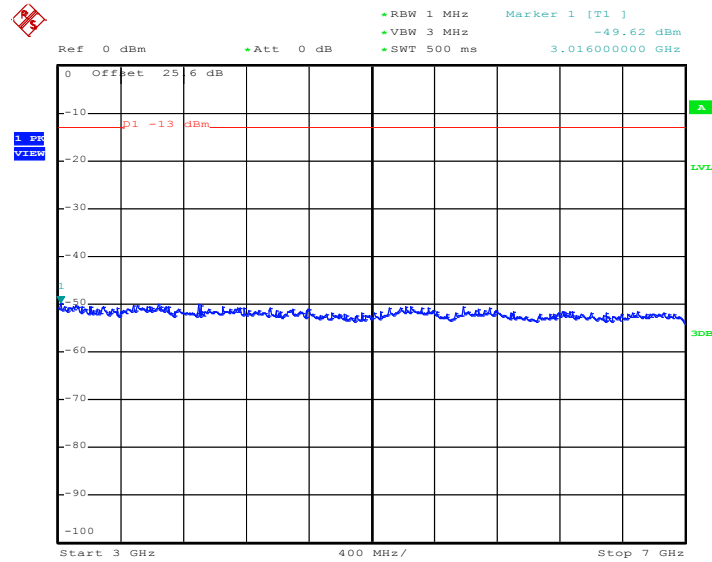

Date: 28.MAR.2012 17:06:51

Conducted Emission Plot between 7GHz ~ 9GHz

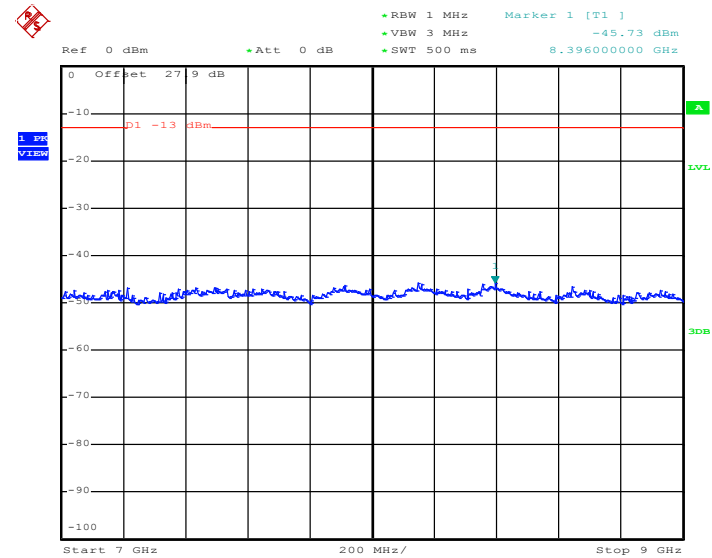

Date: 28.MAR.2012 17:07:04



Band :	GSM1900	Channel :	CH661
Test Mode :	GPRS 8 Link		

Conducted Emission Plot between 30MHz ~ 1GHz

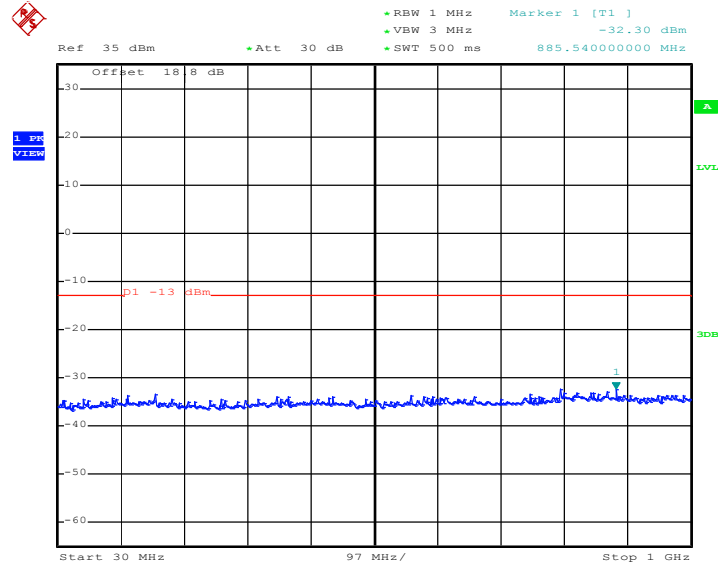

Date: 28.MAR.2012 17:17:34

Conducted Emission Plot between 1GHz ~ 3GHz

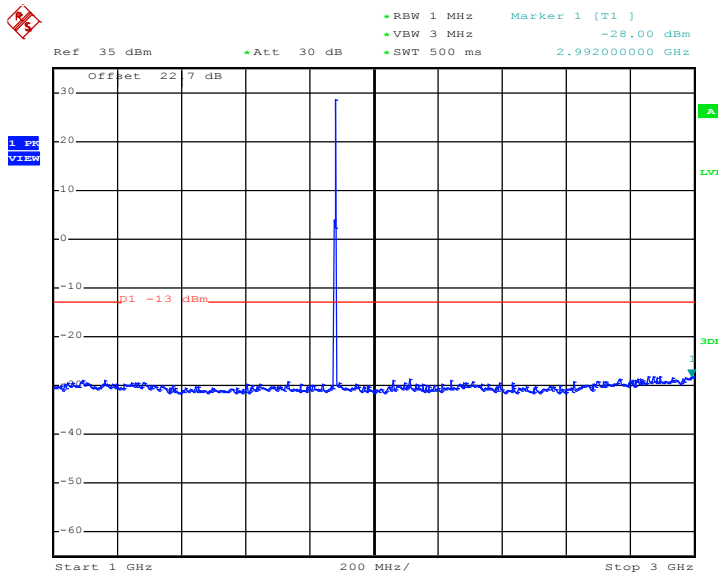

Date: 28.MAR.2012 17:17:47



Conducted Emission Plot between 3GHz ~ 7GHz

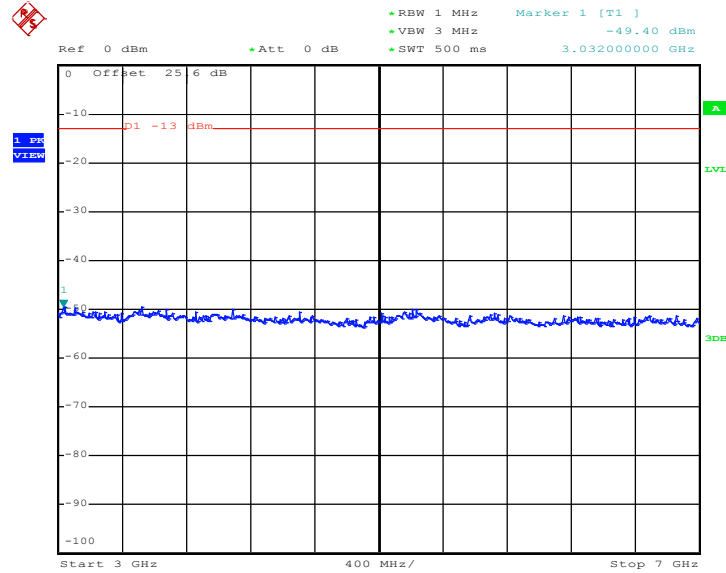

Date: 28.MAR.2012 17:18:13

Conducted Emission Plot between 7GHz ~ 13.6G

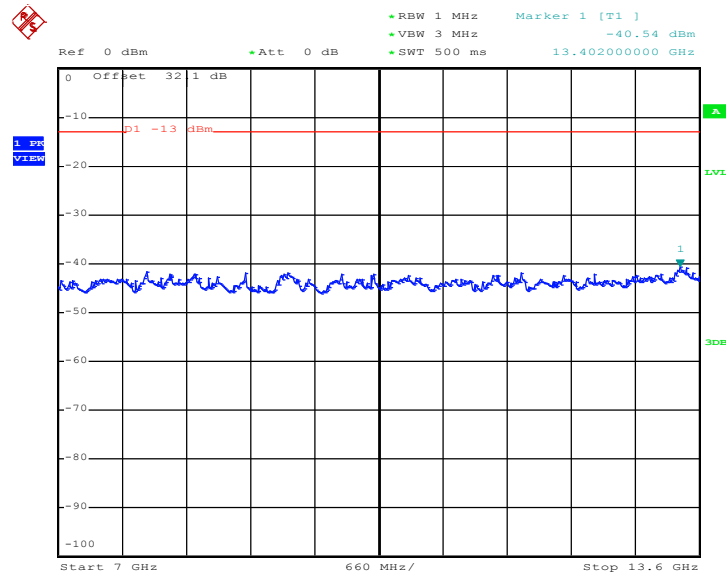

Date: 28.MAR.2012 17:18:25



Conducted Emission Plot between 13.6GHz ~ 19.1GHz

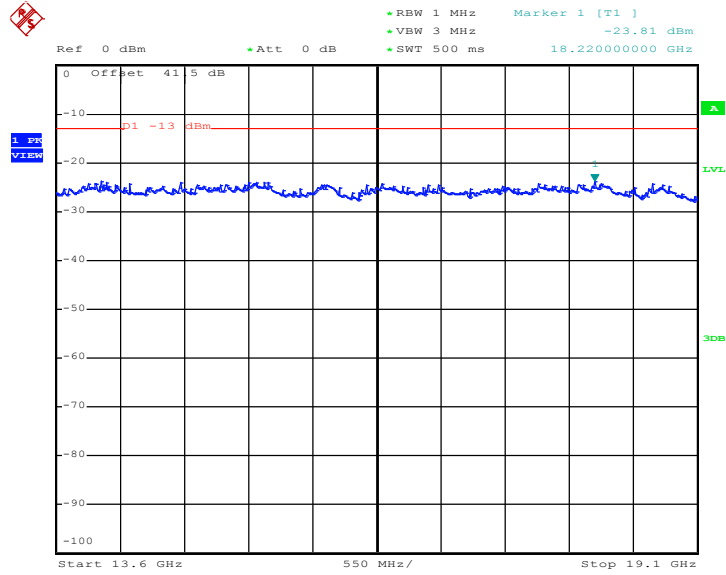

Date: 28.MAR.2012 17:18:38



Band :	GSM1900	Channel :	CH661
Test Mode :	EDGE 8 Link		

Conducted Emission Plot between 30MHz ~ 1GHz

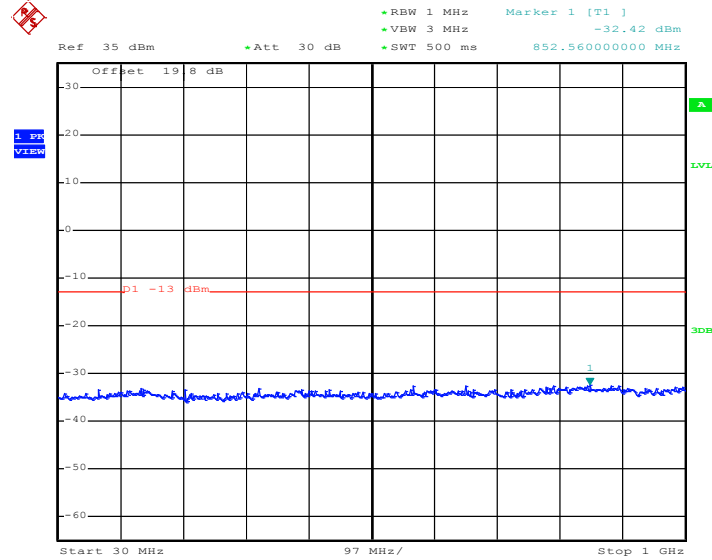

Date: 28.MAR.2012 14:29:39

Conducted Emission Plot between 1GHz ~ 3GHz

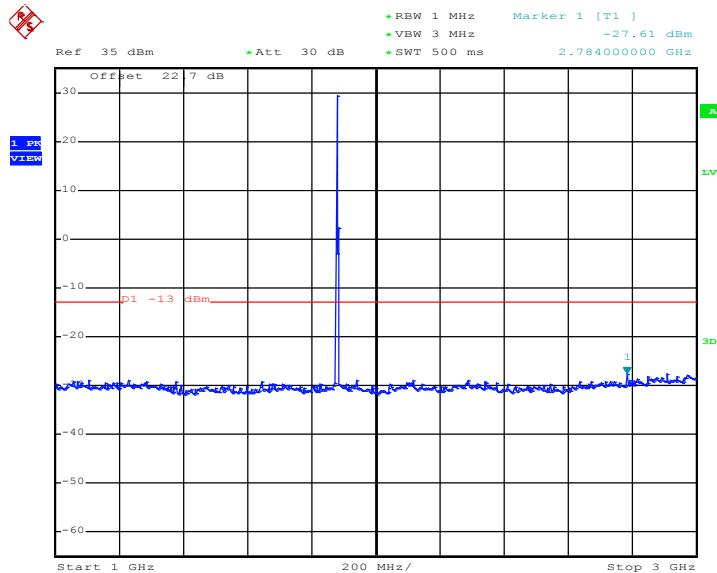

Date: 28.MAR.2012 14:29:52



Conducted Emission Plot between 3GHz ~ 7GHz

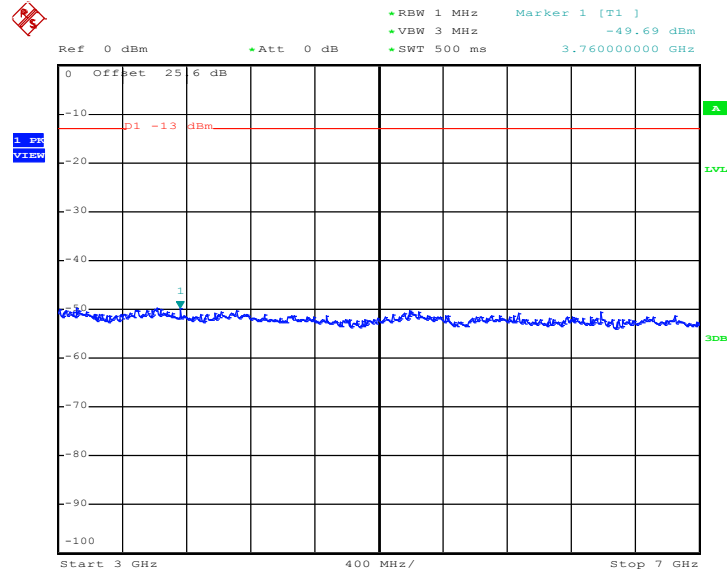

Date: 28.MAR.2012 14:30:10

Conducted Emission Plot between 7GHz ~ 13.6GHz

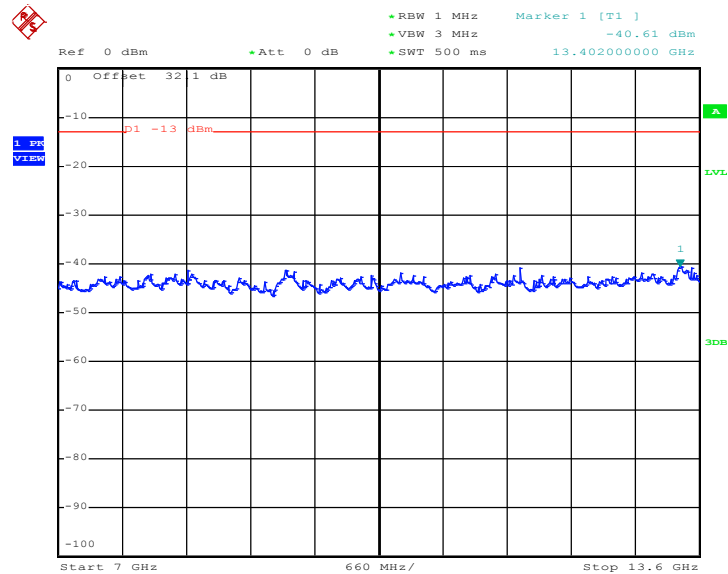

Date: 28.MAR.2012 14:30:23



Conducted Emission Plot between 13.6GHz ~ 19.1GHz

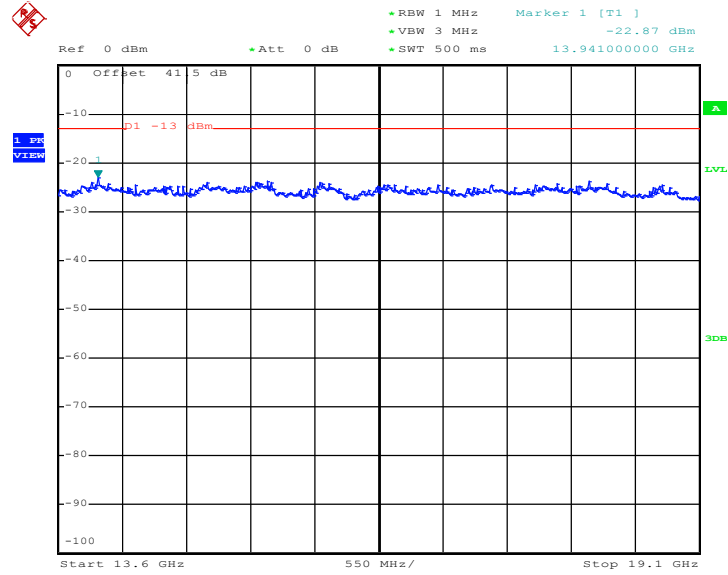

Date: 28.MAR.2012 14:30:36



Band :	WCDMA Band V	Channel :	CH4182
Test Mode :	RMC 12.2Kbps Link		

Conducted Emission Plot between 30MHz ~ 1GHz

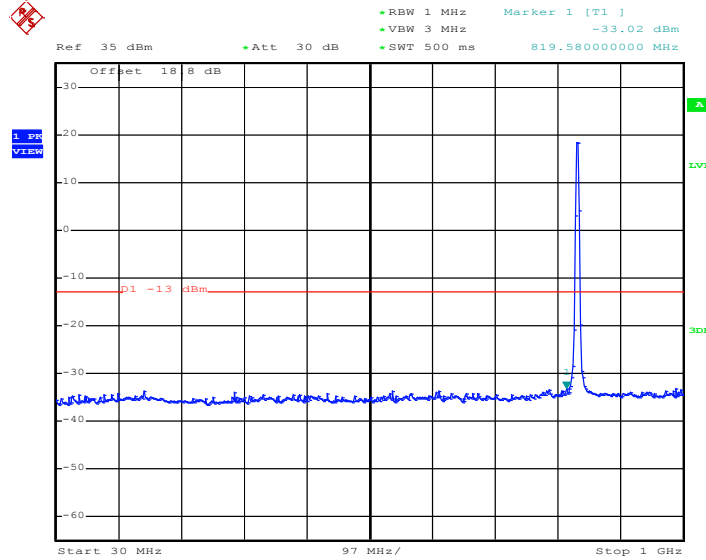

Date: 28.MAR.2012 16:39:24

Conducted Emission Plot between 1GHz ~ 3GHz

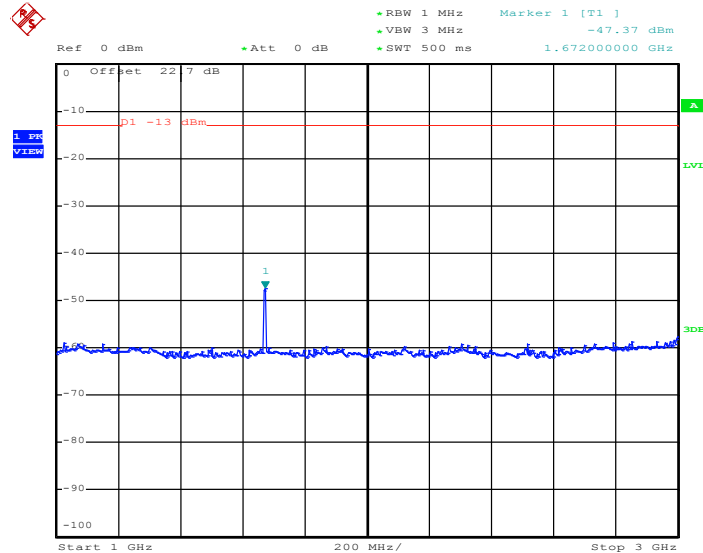

Date: 28.MAR.2012 16:35:55



Conducted Emission Plot between 3GHz ~ 7GHz

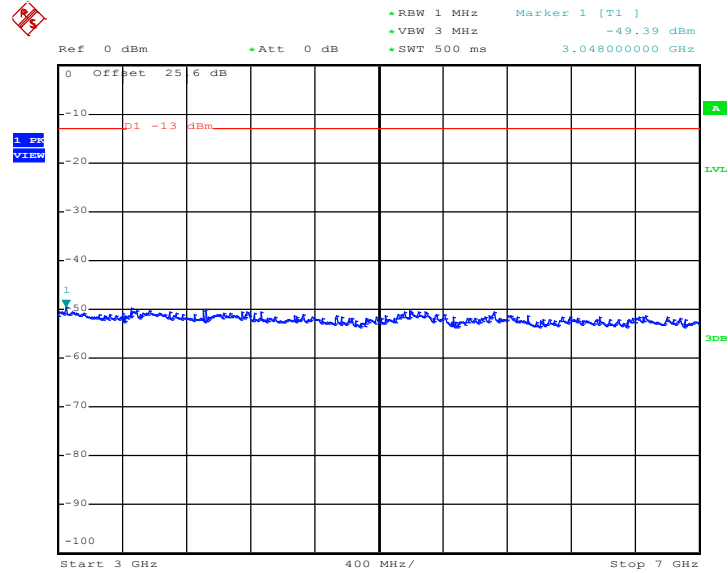

Date: 28.MAR.2012 16:36:08

Conducted Emission Plot between 7GHz ~ 9GHz

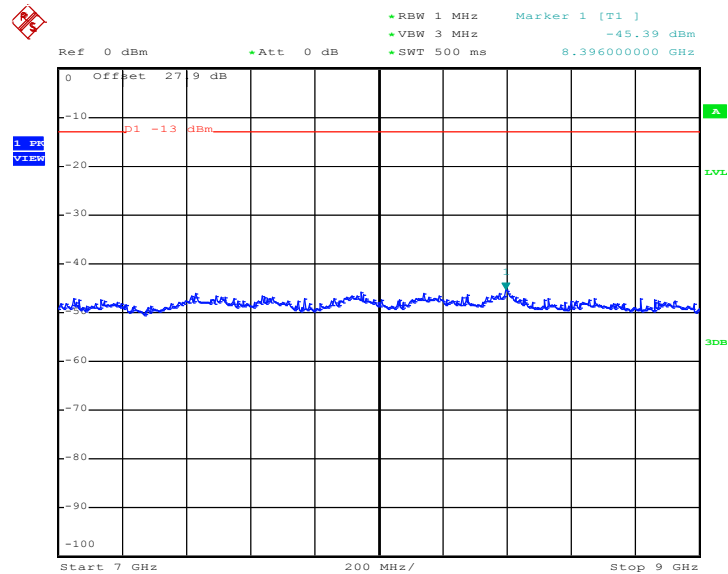

Date: 28.MAR.2012 16:36:21



Band :	WCDMA Band IV	Channel :	CH1413
Test Mode :	RMC 12.2Kbps Link		

Conducted Emission Plot between 30MHz ~ 1GHz

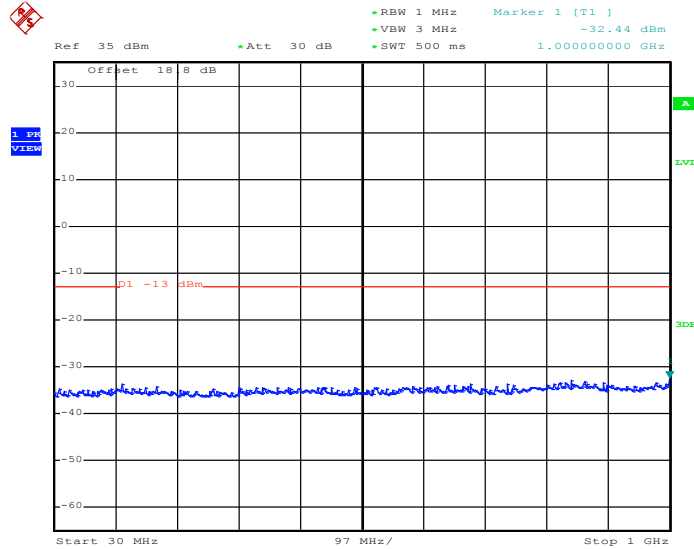

Date: 28.MAR.2012 17:27:55

Conducted Emission Plot between 1GHz ~ 3GHz

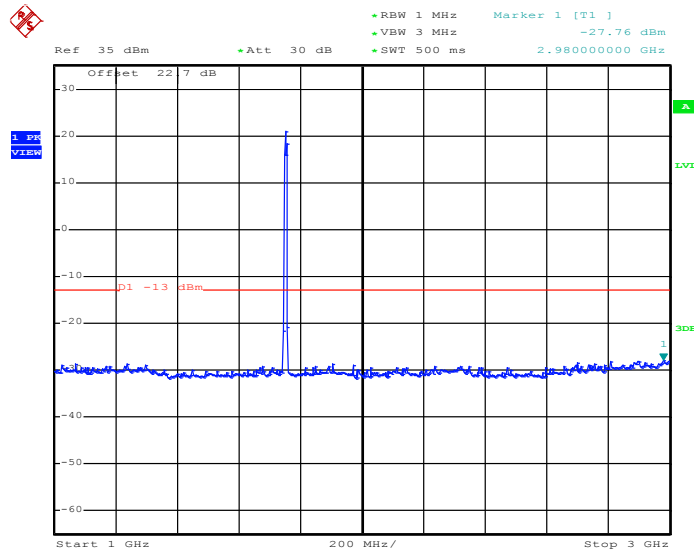

Date: 28.MAR.2012 17:28:07



Conducted Emission Plot between 3GHz ~ 7GHz

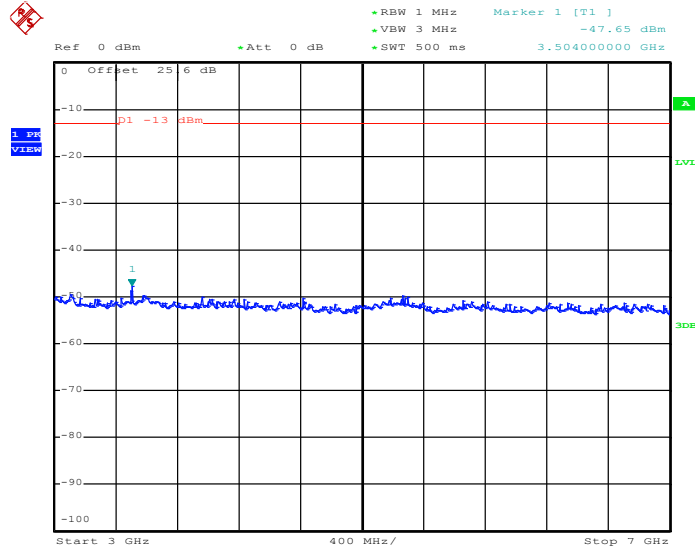

Date: 28.MAR.2012 17:28:26

Conducted Emission Plot between 7GHz ~ 13.6GHz

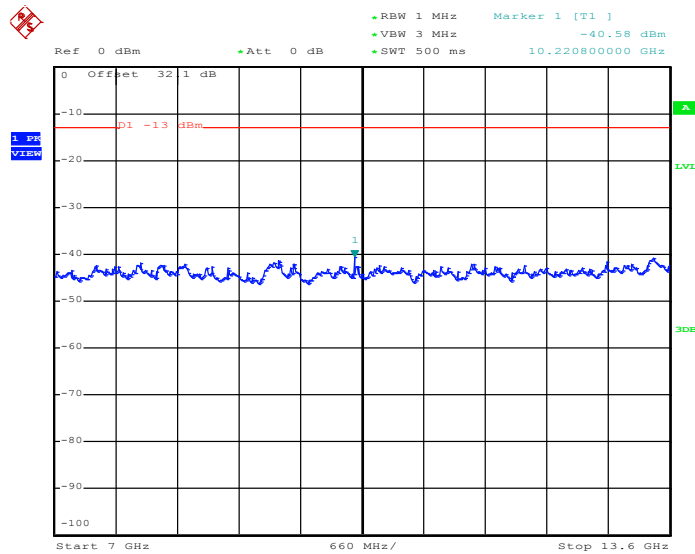

Date: 28.MAR.2012 17:28:38



Conducted Emission Plot between 13.6GHz ~ 18GHz

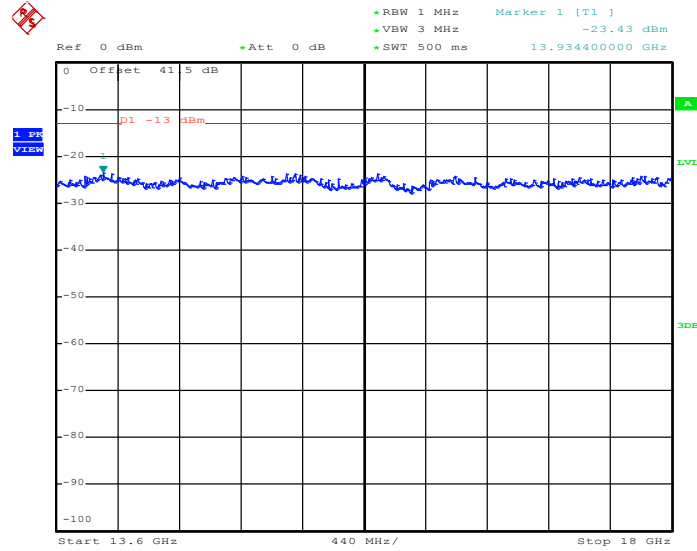

Date: 28.MAR.2012 17:28:51



Band :	WCDMA Band II	Channel :	CH9400
Test Mode :	RMC 12.2Kbps Link		

Conducted Emission Plot between 30MHz ~ 1GHz

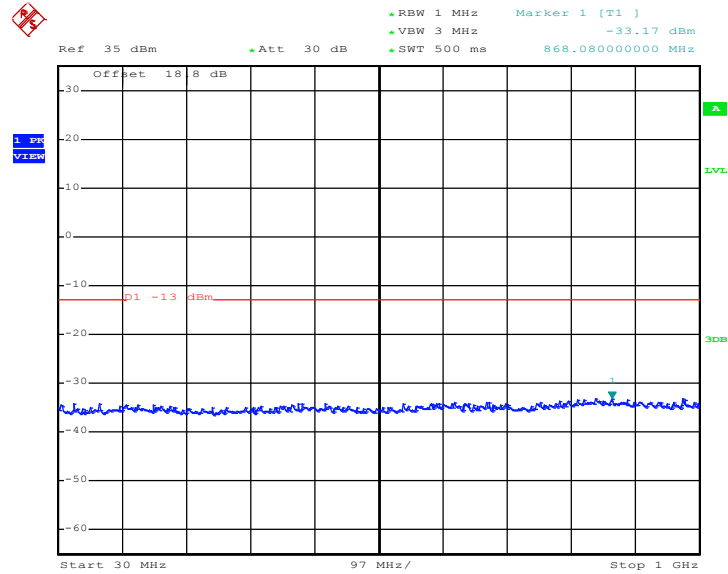

Date: 28.MAR.2012 16:44:31

Conducted Emission Plot between 1GHz ~ 3GHz

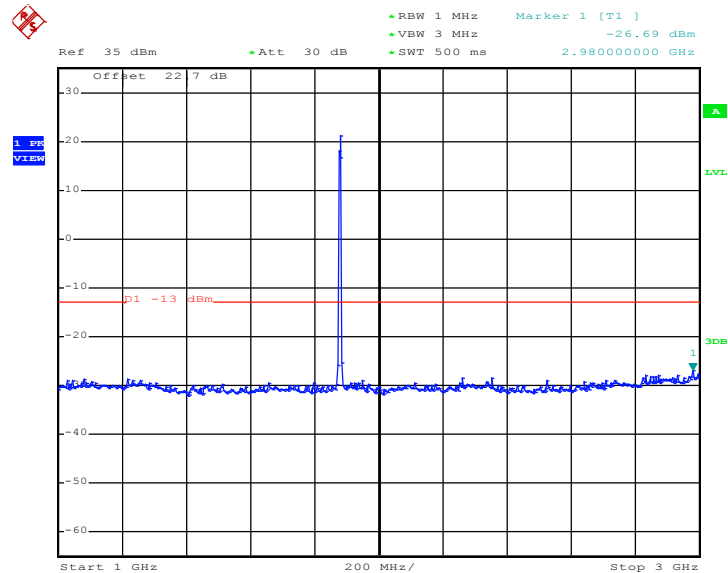

Date: 28.MAR.2012 16:44:44



Conducted Emission Plot between 3GHz ~ 7GHz

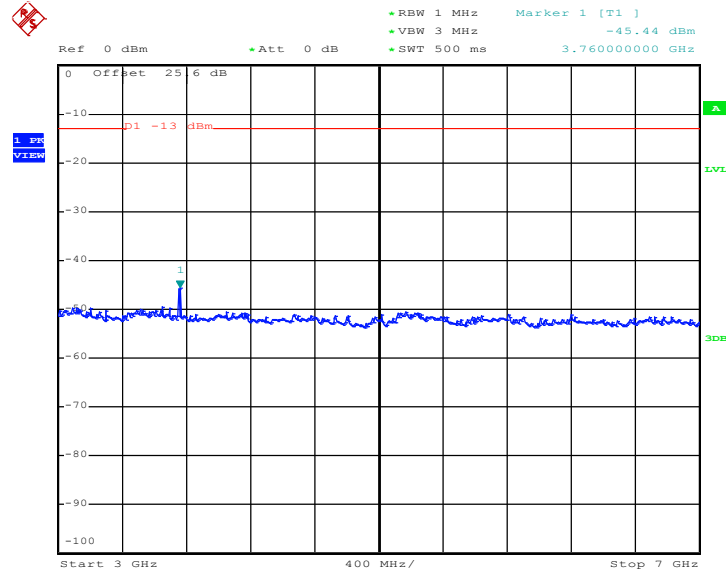

Date: 28.MAR.2012 16:45:07

Conducted Emission Plot between 7GHz ~ 13.6GHz

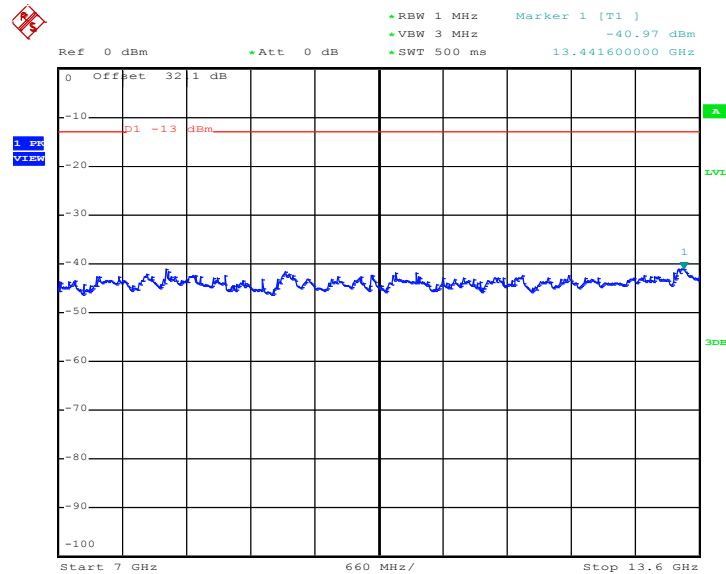

Date: 28.MAR.2012 16:45:19



Conducted Emission Plot between 13.6GHz ~ 19.1GHz

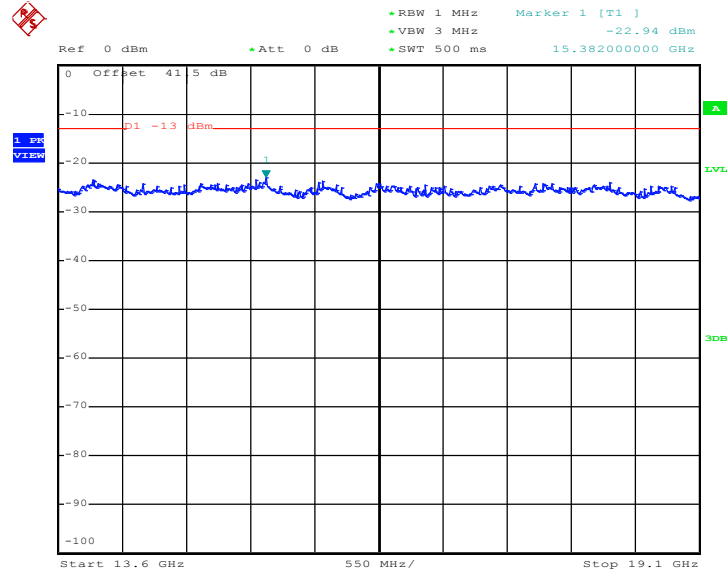

Date: 28.MAR.2012 16:45:32

3.6 Field Strength of Spurious Radiation Measurement

3.6.1 Description of Field Strength of Spurious Radiated Measurement

The radiated spurious emission was measured by substitution method according to ANSI / TIA / EIA-603-C-2004. The power of any emission outside of the authorized operating frequency ranges must be attenuated below the transmitter power (P) by a factor of at least $43 + 10 \log (P)$ dB. The spectrum is scanned from 30 MHz up to a frequency including its 10th harmonic.

3.6.2 Measuring Instruments

See list of measuring instruments of this test report.

3.6.3 Test Procedures

1. The EUT was placed on a rotatable wooden table with 0.8 meter about ground.
2. The EUT was set 3 meters from the receiving antenna, which was mounted on the antenna tower.
3. The table was rotated 360 degrees to determine the position of the highest spurious emission.
4. The height of the receiving antenna is varied between one meter and four meters to search the maximum spurious emission for both horizontal and vertical polarizations.
5. Taking the record of maximum spurious emission.
6. A horn antenna was substituted in place of the EUT and was driven by a signal generator.
7. Tune the output power of signal generator to the same emission level with EUT maximum spurious emission.
8. Taking the record of output power at antenna port.
9. Repeat step 7 to step 8 for another polarization.
10. $EIRP \text{ (dBm)} = S.G. \text{ Power} - Tx \text{ Cable Loss} + Tx \text{ Antenna Gain}$
11. $ERP \text{ (dBm)} = EIRP - 2.15$

3.6.4 Test Setup

For radiated emissions below 30MHz

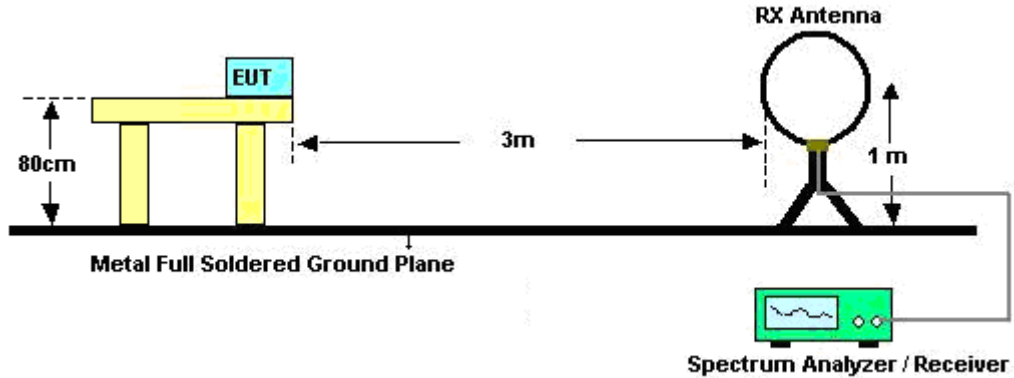

For radiated emissions above 30MHz

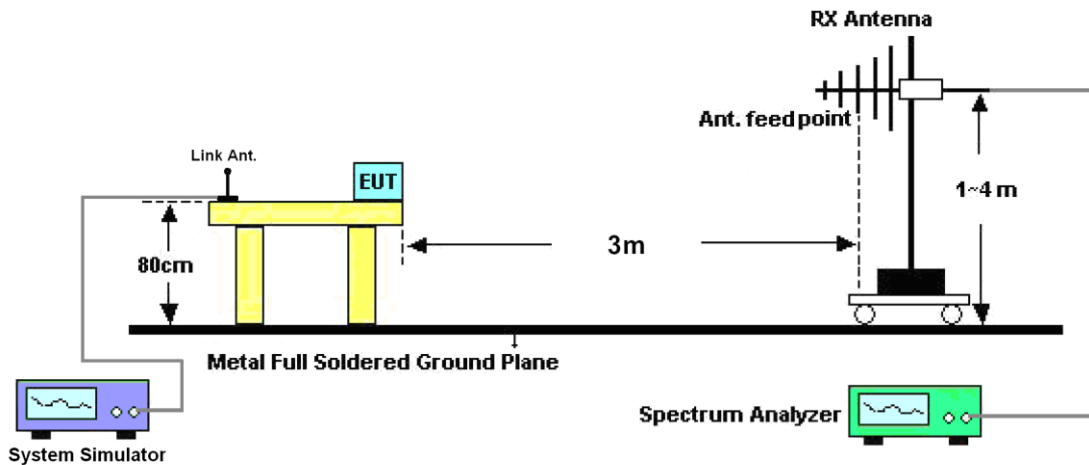

3.6.5 Test Results of Radiated Emissions (9 KHz ~ 30 MHz)

The low frequency, which started from 9 KHz to 30MHz, was pre-scanned and the result which was 20dB lower than the limit line per 15.31(o) was not reported.



3.6.6 Test Result of Field Strength of Spurious Radiated

Band :	GSM850	Temperature :	23~24°C
Test Mode :	GPRS 8 Link	Relative Humidity :	45~47%
Test Engineer :	David Ke and Kai Wang	Polarization :	Horizontal
Remark :	Spurious emissions within 30-1000MHz were found more than 20dB below limit line.		

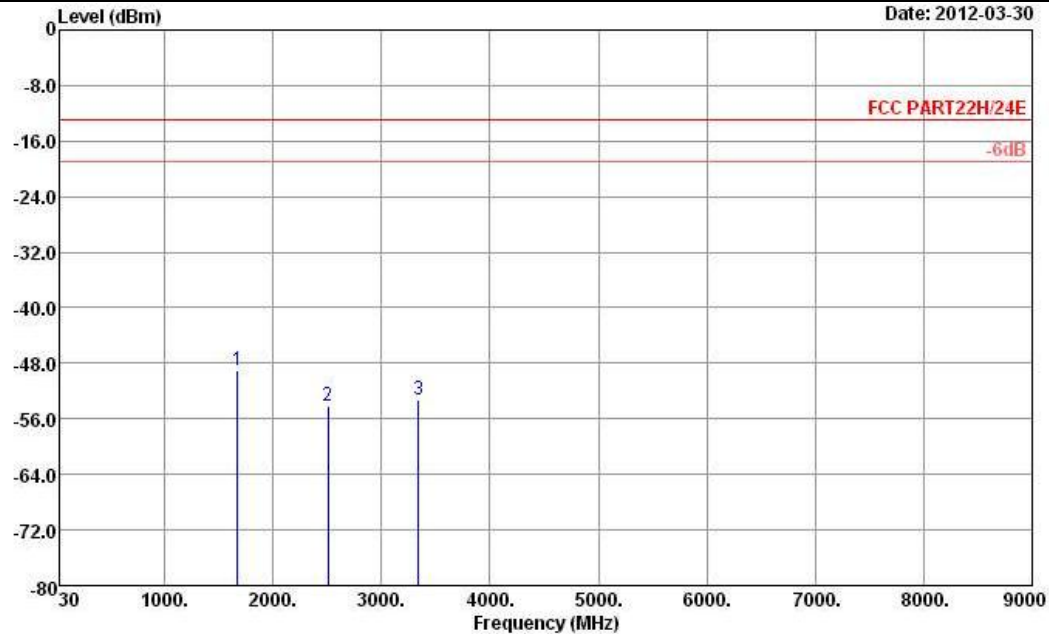

Site : 03CH05-HY
 Condition : FCC PART22H/24E HF_EIRP_101221 HORIZONTAL
 Project : FG 1D0814

Frequency (MHz)	ERP (dBm)	Limit (dBm)	Over Limit (dB)	SPA Reading (dBm)	S.G. Power (dBm)	TX Cable loss (dB)	TX Antenna Gain (dBi)	Polarization (H/V)	Result
1672	-49.04	-13	-36.04	-55.21	-50.23	2.15	5.49	H	Pass
2509	-54.22	-13	-41.22	-63.56	-56.11	2.38	6.41	H	Pass
3345	-53.22	-13	-40.22	-64.86	-56.55	2.86	8.34	H	Pass



Band :	GSM850	Temperature :	23~24°C
Test Mode :	GPRS 8 Link	Relative Humidity :	45~47%
Test Engineer :	David Ke and Kai Wang	Polarization :	Vertical
Remark :	Spurious emissions within 30-1000MHz were found more than 20dB below limit line.		

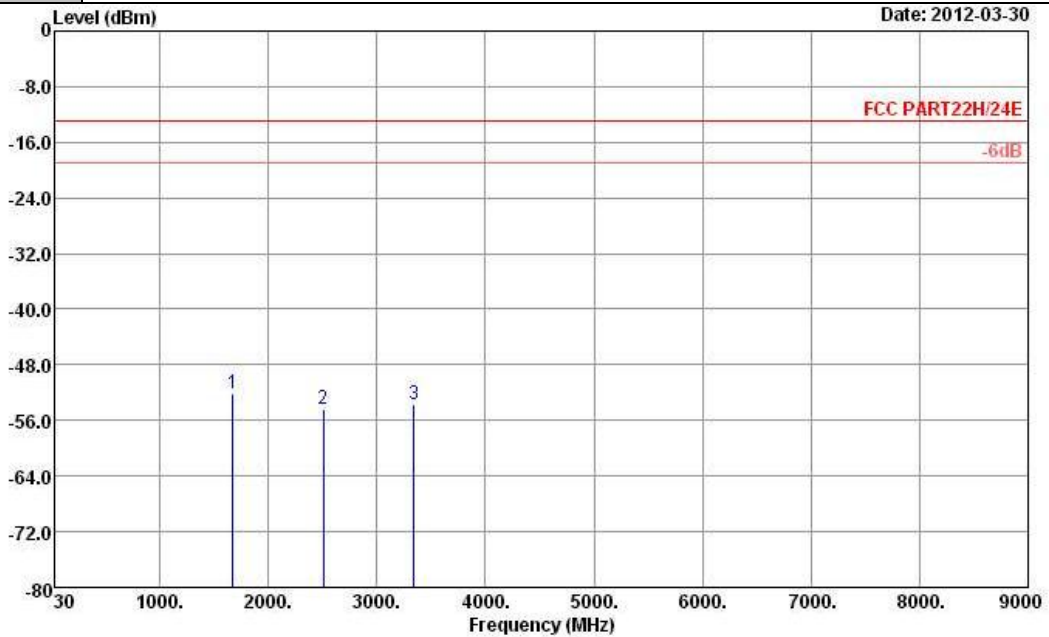

Site : 03CH05-HY
 Condition : FCC PART22H/24E HF_EIRP_101221 VERTICAL
 Project : FG 1D0814

Frequency (MHz)	ERP (dBm)	Limit (dBm)	Over Limit (dB)	SPA Reading (dBm)	S.G. Power (dBm)	TX Cable loss (dB)	TX Antenna Gain (dBi)	Polarization (H/V)	Result
1672	-52.04	-13	-39.04	-58.16	-53.23	2.15	5.49	V	Pass
2509	-54.44	-13	-41.44	-63.86	-56.33	2.38	6.41	V	Pass
3345	-53.67	-13	-40.67	-65.31	-57	2.86	8.34	V	Pass



Band :	GSM850	Temperature :	23~24°C
Test Mode :	EDGE 8 Link	Relative Humidity :	45~47%
Test Engineer :	David Ke and Kai Wang	Polarization :	Horizontal
Remark :	Spurious emissions within 30-1000MHz were found more than 20dB below limit line.		

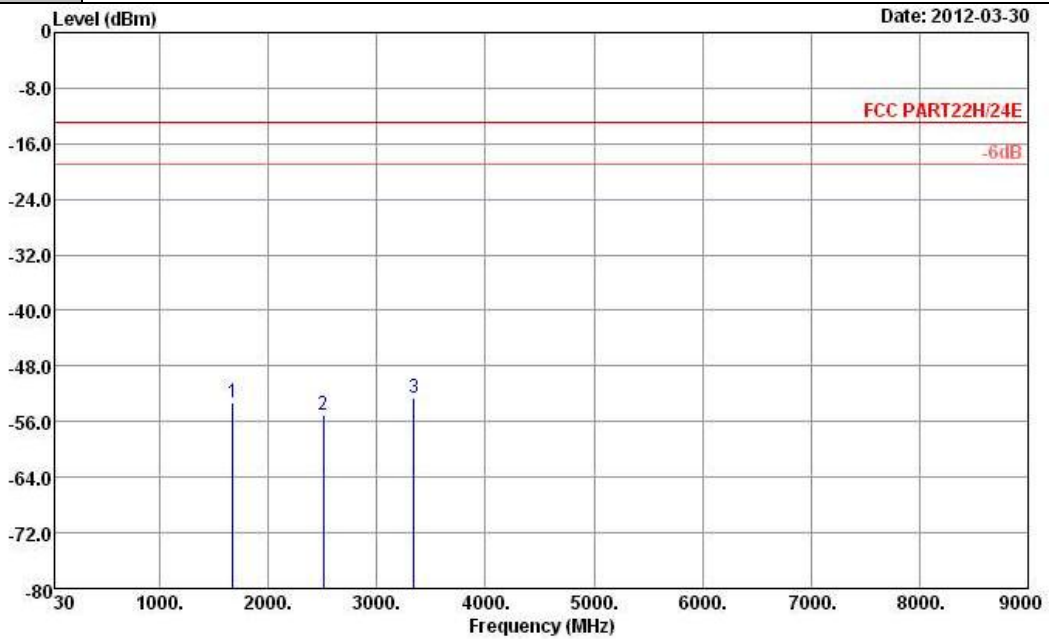

Site : 03CH05-HY
 Condition : FCC PART22H/24E HF_EIRP_101221 HORIZONTAL
 Project : FG 1D0814

Frequency (MHz)	ERP (dBm)	Limit (dBm)	Over Limit (dB)	SPA Reading (dBm)	S.G. Power (dBm)	TX Cable loss (dB)	TX Antenna Gain (dBi)	Polarization (H/V)	Result
1672	-53.35	-13	-40.35	-59.5	-54.54	2.15	5.49	H	Pass
2509	-55.11	-13	-42.11	-64.44	-57	2.38	6.41	H	Pass
3345	-52.67	-13	-39.67	-64.32	-56	2.86	8.34	H	Pass



Band :	GSM850	Temperature :	23~24°C
Test Mode :	EDGE 8 Link	Relative Humidity :	45~47%
Test Engineer :	David Ke and Kai Wang	Polarization :	Vertical
Remark :	Spurious emissions within 30-1000MHz were found more than 20dB below limit line.		

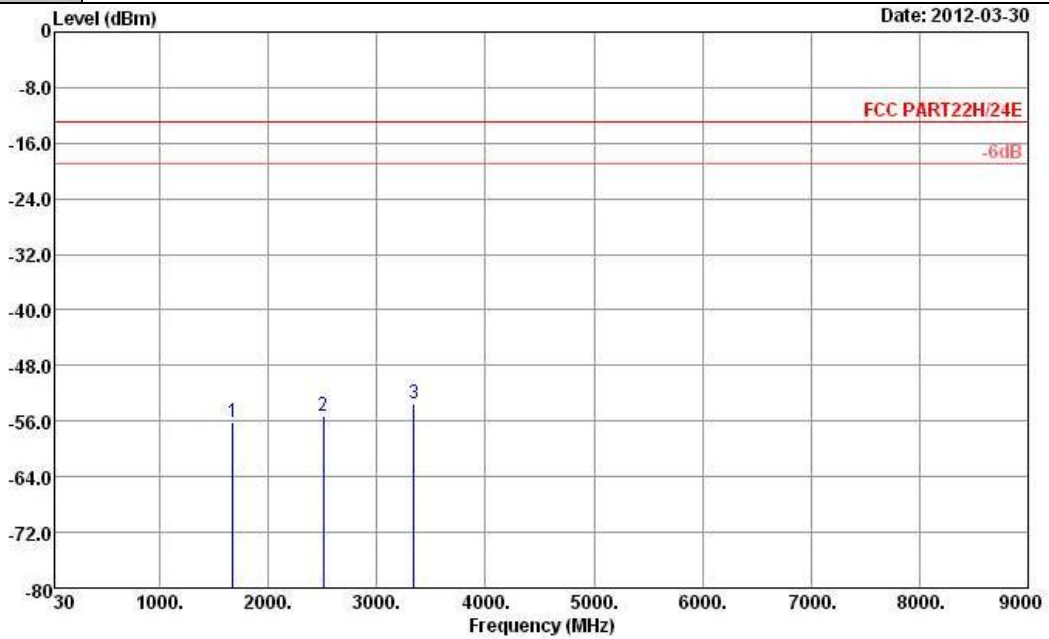

Site : 03CH05-HY
 Condition : FCC PART22H/24E HF_EIRP_101221 VERTICAL
 Project : FG 1D0814

Frequency (MHz)	ERP (dBm)	Limit (dBm)	Over Limit (dB)	SPA Reading (dBm)	S.G. Power (dBm)	TX Cable loss (dB)	TX Antenna Gain (dBi)	Polarization (H/V)	Result
1672	-56.12	-13	-43.12	-62.18	-57.31	2.15	5.49	V	Pass
2509	-55.23	-13	-42.23	-64.65	-57.12	2.38	6.41	V	Pass
3345	-53.41	-13	-40.41	-65.04	-56.74	2.86	8.34	V	Pass



Band :	GSM1900	Temperature :	23~24°C
Test Mode :	GPRS 8 Link	Relative Humidity :	45~47%
Test Engineer :	David Ke and Kai Wang	Polarization :	Horizontal
Remark :	Spurious emissions within 30-1000MHz were found more than 20dB below limit line.		

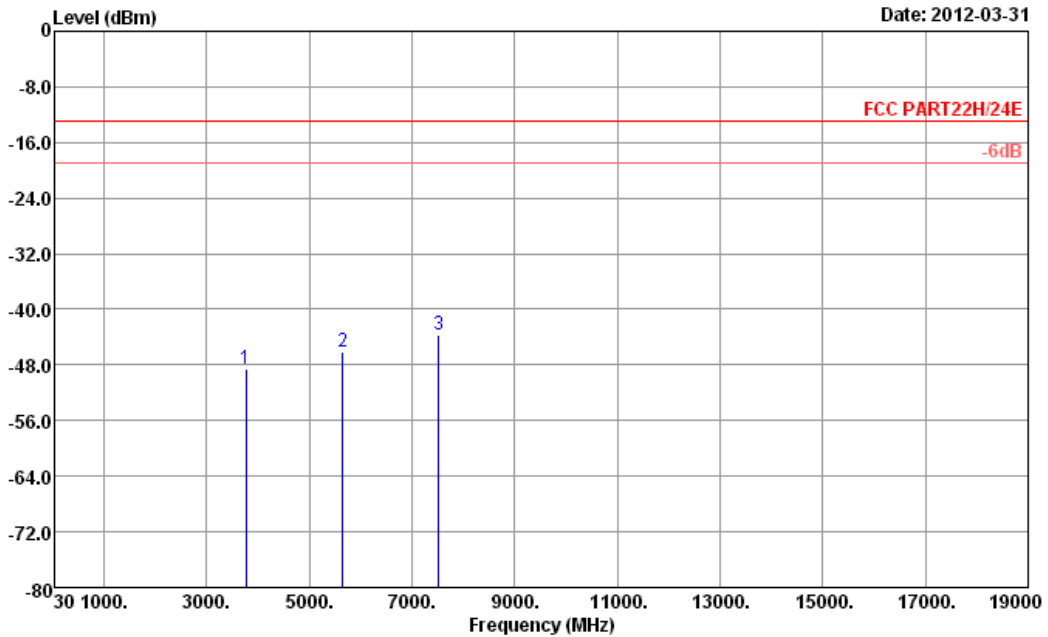

Site : 03CH05-HY
 Condition : FCC PART22H/24E HF_EIRP_101221 HORIZONTAL
 Project : FG 1D0814

Frequency (MHz)	EIRP (dBm)	Limit (dBm)	Over Limit (dB)	SPA Reading (dBm)	S.G. Power (dBm)	TX Cable loss (dB)	TX Antenna Gain (dBi)	Polarization (H/V)	Result
3760	-48.55	-13	-35.55	-61.61	-54.68	2.9292	9.06	H	Pass
5640	-46.04	-13	-33.04	-64.7	-52.96	3.9072	10.83	H	Pass
7520	-43.70	-13	-30.70	-65.38	-51.72	4.5988	12.62	H	Pass



Band :	GSM1900	Temperature :	23~24°C
Test Mode :	GPRS 8 Link	Relative Humidity :	45~47%
Test Engineer :	David Ke and Kai Wang	Polarization :	Vertical
Remark :	Spurious emissions within 30-1000MHz were found more than 20dB below limit line.		

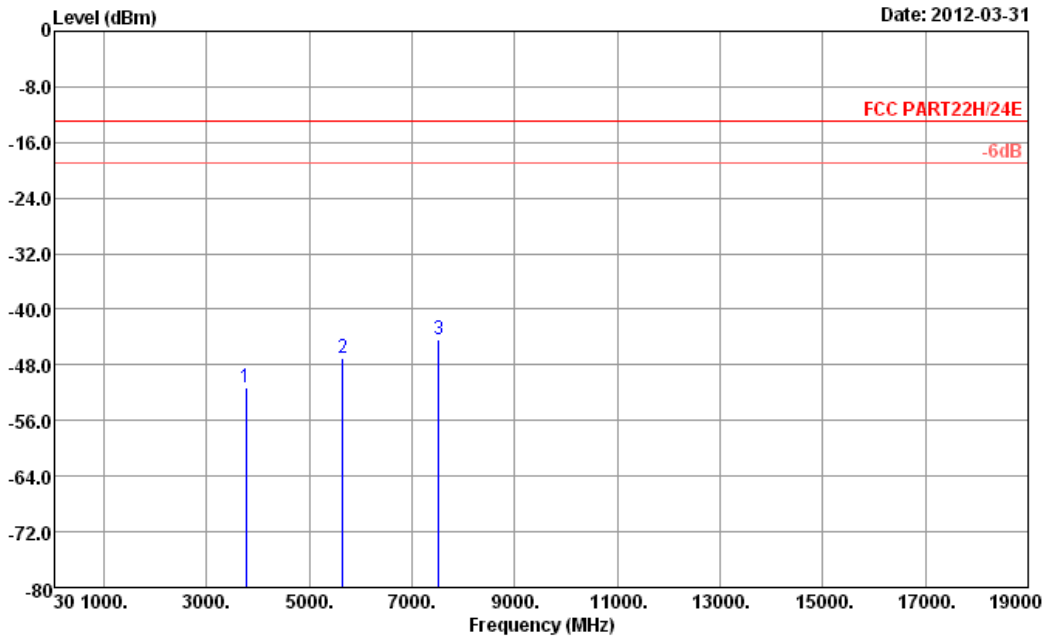

Site : 03CH05-HY
 Condition : FCC PART22H/24E HF_EIRP_101221 VERTICAL
 Project : FG 1D0814

Frequency (MHz)	EIRP (dBm)	Limit (dBm)	Over Limit (dB)	SPA Reading (dBm)	S.G. Power (dBm)	TX Cable loss (dB)	TX Antenna Gain (dBi)	Polarization (H/V)	Result
3760	-51.22	-13	-38.22	-64.23	-57.35	2.9292	9.06	V	Pass
5640	-47.10	-13	-34.10	-65.69	-54.02	3.9072	10.83	V	Pass
7520	-44.34	-13	-31.34	-65.89	-52.36	4.5988	12.62	V	Pass



Band :	GSM1900	Temperature :	23~24°C
Test Mode :	EDGE 8 Link	Relative Humidity :	45~47%
Test Engineer :	David Ke and Kai Wang	Polarization :	Horizontal
Remark :	Spurious emissions within 30-1000MHz were found more than 20dB below limit line.		

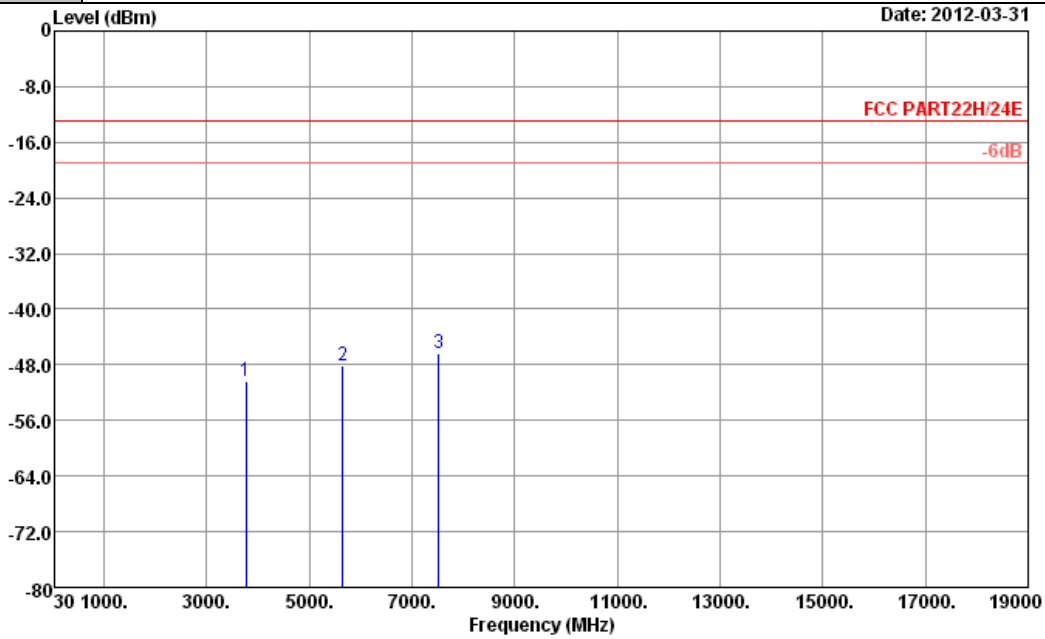

Site : 03CH05-HY
 Condition : FCC PART22H/24E HF_EIRP_101221 HORIZONTAL
 Project : FG 1D0814

Frequency (MHz)	EIRP (dBm)	Limit (dBm)	Over Limit (dB)	SPA Reading (dBm)	S.G. Power (dBm)	TX Cable loss (dB)	TX Antenna Gain (dBi)	Polarization (H/V)	Result
3760	-50.33	-13	-37.33	-63.31	-56.46	2.9292	9.06	H	Pass
5640	-48.20	-13	-35.20	-66.76	-55.12	3.9072	10.83	H	Pass
7520	-46.34	-13	-33.34	-67.91	-54.36	4.5988	12.62	H	Pass



Band :	GSM1900	Temperature :	23~24°C
Test Mode :	EDGE 8 Link	Relative Humidity :	45~47%
Test Engineer :	David Ke and Kai Wang	Polarization :	Vertical
Remark :	Spurious emissions within 30-1000MHz were found more than 20dB below limit line.		

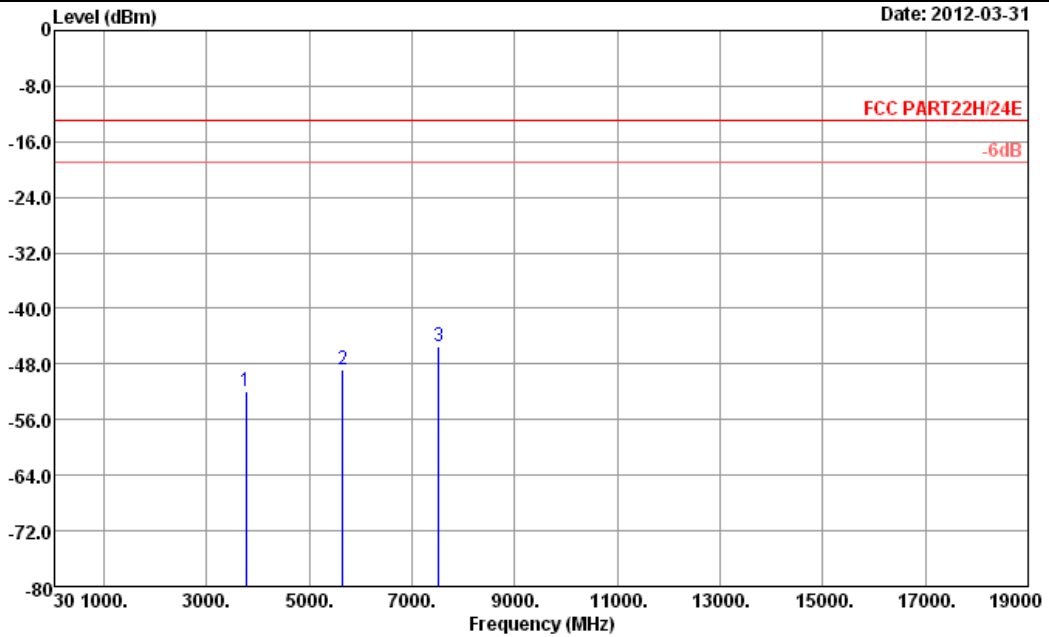

Site : 03CH05-HY
 Condition : FCC PART22H/24E HF_EIRP_101221 VERTICAL
 Project : FG 1D0814

Frequency (MHz)	EIRP (dBm)	Limit (dBm)	Over Limit (dB)	SPA Reading (dBm)	S.G. Power (dBm)	TX Cable loss (dB)	TX Antenna Gain (dBi)	Polarization (H/V)	Result
3760	-51.90	-13	-38.90	-65.03	-58.03	2.9292	9.06	V	Pass
5640	-48.81	-13	-35.81	-67.08	-55.73	3.9072	10.83	V	Pass
7520	-45.43	-13	-32.43	-67.05	-53.45	4.5988	12.62	V	Pass



Band :	WCDMA Band V	Temperature :	23~24°C
Test Mode :	RMC 12.2Kbps Link	Relative Humidity :	45~47%
Test Engineer :	David Ke and Kai Wang	Polarization :	Horizontal
Remark :	Spurious emissions within 30-1000MHz were found more than 20dB below limit line.		

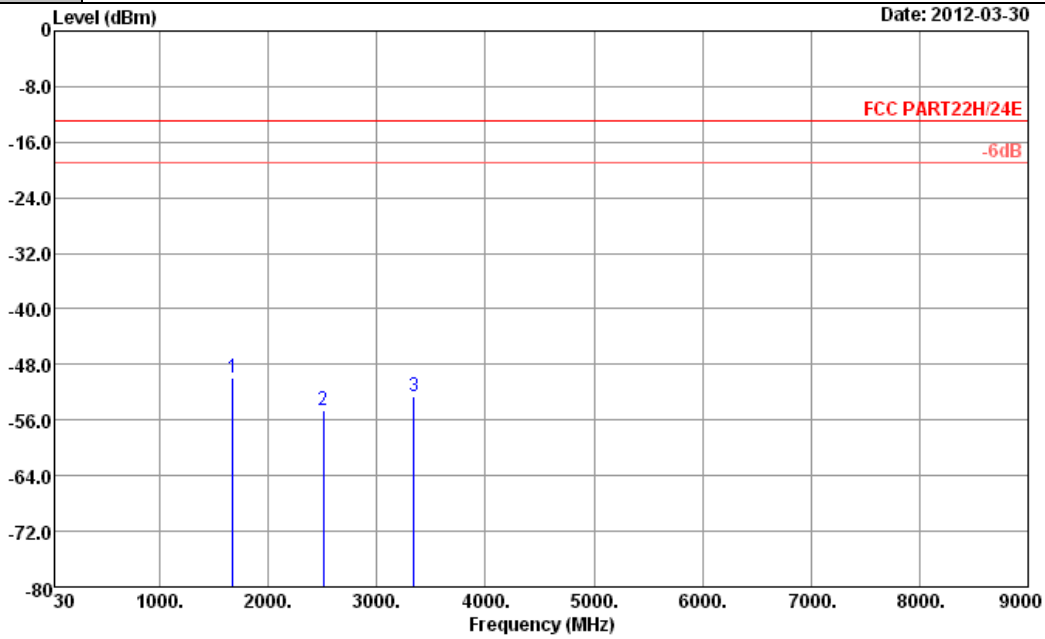

Site : 03CH05-HY
 Condition : FCC PART22H/24E HF_EIRP_101221 HORIZONTAL
 Project : FG 1D0814

Frequency (MHz)	ERP (dBm)	Limit (dBm)	Over Limit (dB)	SPA Reading (dBm)	S.G. Power (dBm)	TX Cable loss (dB)	TX Antenna Gain (dBi)	Polarization (H/V)	Result
1672	-50.01	-13	-37.01	-55.89	-51.2	2.15	5.49	H	Pass
2509	-54.56	-13	-41.56	-63.99	-56.45	2.38	6.41	H	Pass
3345	-52.67	-13	-39.67	-64.28	-56	2.86	8.34	H	Pass



Band :	WCDMA Band V	Temperature :	23~24°C
Test Mode :	RMC 12.2Kbps Link	Relative Humidity :	45~47%
Test Engineer :	David Ke and Kai Wang	Polarization :	Vertical
Remark :	Spurious emissions within 30-1000MHz were found more than 20dB below limit line.		

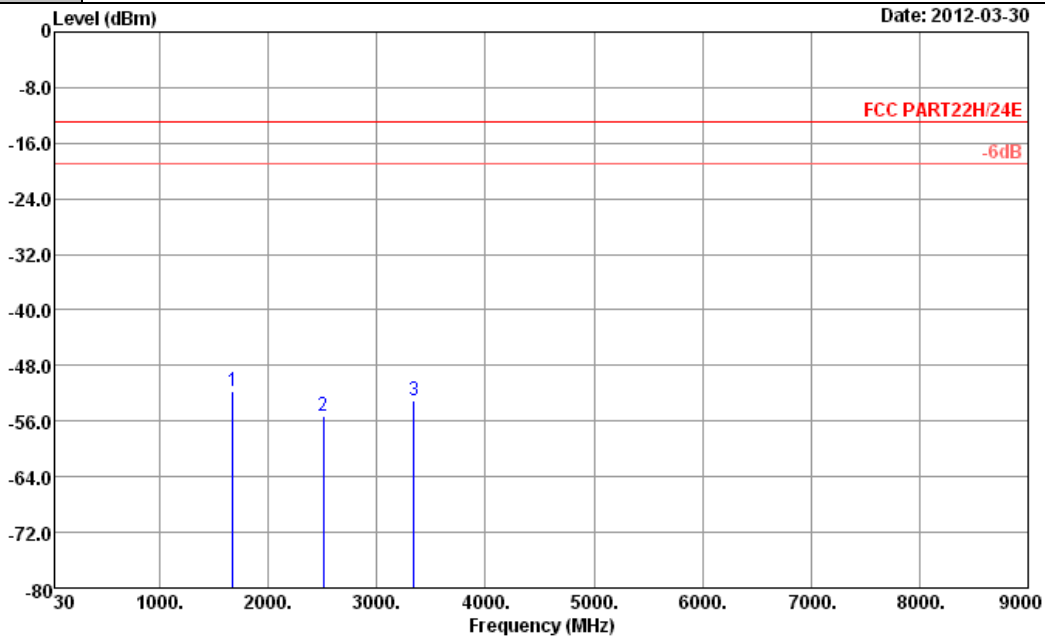

Site : 03CH05-HY
 Condition : FCC PART22H/24E HF_EIRP_101221 VERTICAL
 Project : FG 1D0814

Frequency (MHz)	ERP (dBm)	Limit (dBm)	Over Limit (dB)	SPA Reading (dBm)	S.G. Power (dBm)	TX Cable loss (dB)	TX Antenna Gain (dBi)	Polarization (H/V)	Result
1672	-51.81	-13	-38.81	-57.83	-53	2.15	5.49	V	Pass
2509	-55.33	-13	-42.33	-64.64	-57.22	2.38	6.41	V	Pass
3345	-53.00	-13	-40.00	-64.62	-56.33	2.86	8.34	V	Pass



Band :	WCDMA Band IV	Temperature :	23~24°C
Test Mode :	RMC 12.2Kbps Link	Relative Humidity :	45~47%
Test Engineer :	David Ke and Kai Wang	Polarization :	Horizontal
Remark :	Spurious emissions within 30-1000MHz were found more than 20dB below limit line.		

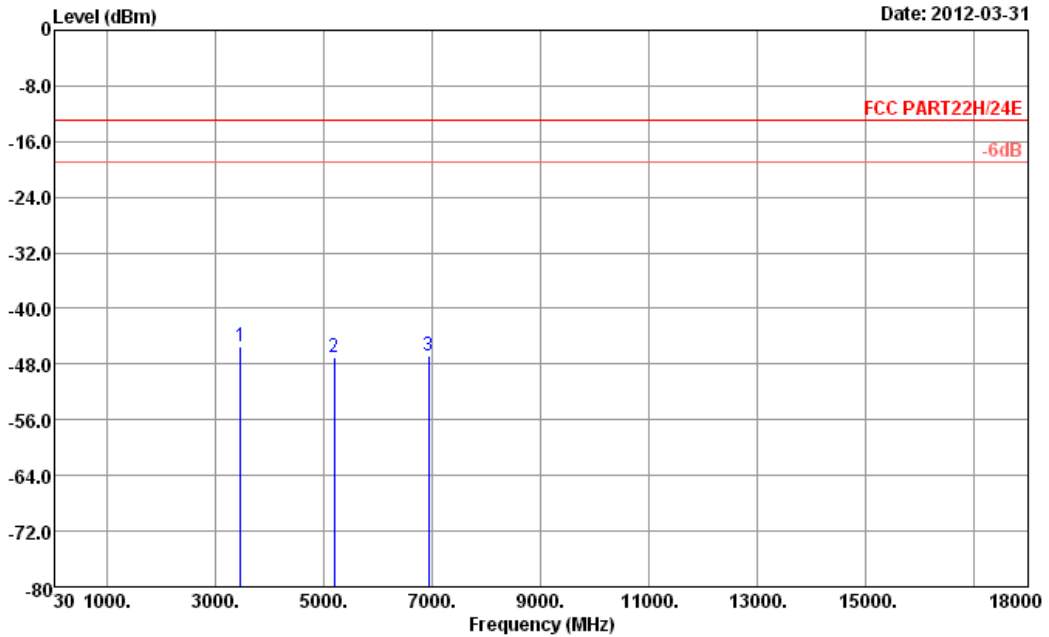

Site : 03CH05-HY
 Condition : FCC PART22H/24E HF_EIRP_101221 HORIZONTAL
 Project : FG 1D0814

Frequency (MHz)	EIRP (dBm)	Limit (dBm)	Over Limit (dB)	SPA Reading (dBm)	S.G. Power (dBm)	TX Cable loss (dB)	TX Antenna Gain (dBi)	Polarization (H/V)	Result
3465.2	-45.50	-13	-32.50	-57.11	-51.76	2.58	8.84	H	Pass
5197.8	-47.08	-13	-34.08	-64.62	-54.02	3.78	10.72	H	Pass
6930.4	-46.87	-13	-33.87	-67.60	-54.62	4.3	12.05	H	Pass



Band :	WCDMA Band IV	Temperature :	23~24°C
Test Mode :	RMC 12.2Kbps Link	Relative Humidity :	45~47%
Test Engineer :	David Ke and Kai Wang	Polarization :	Vertical
Remark :	Spurious emissions within 30-1000MHz were found more than 20dB below limit line.		

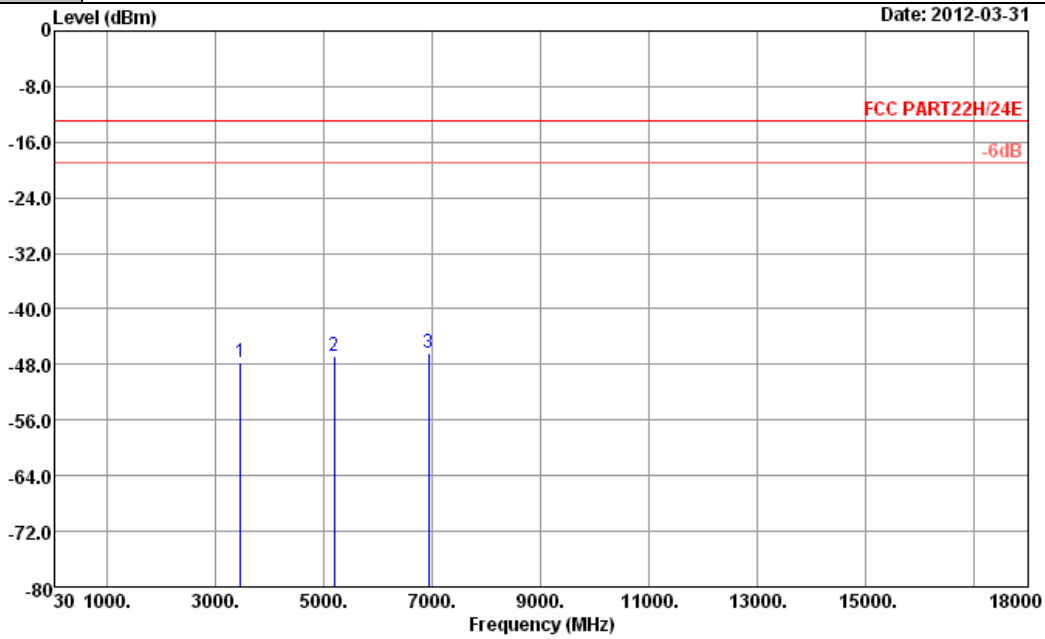

Site : 03CH05-HY
 Condition : FCC PART22H/24E HF_EIRP_101221 VERTICAL
 Project : FG 1D0814

Frequency (MHz)	EIRP (dBm)	Limit (dBm)	Over Limit (dB)	SPA Reading (dBm)	S.G. Power (dBm)	TX Cable loss (dB)	TX Antenna Gain (dBi)	Polarization (H/V)	Result
3465.2	-47.69	-13	-34.69	-59.28	-53.95	2.58	8.84	V	Pass
5197.8	-46.78	-13	-33.78	-64.17	-53.72	3.78	10.72	V	Pass
6930.4	-46.46	-13	-33.46	-67.23	-54.21	4.3	12.05	V	Pass



Band :	WCDMA Band II	Temperature :	23~24°C
Test Mode :	RMC 12.2Kbps Link	Relative Humidity :	45~47%
Test Engineer :	David Ke and Kai Wang	Polarization :	Horizontal
Remark :	Spurious emissions within 30-1000MHz were found more than 20dB below limit line.		

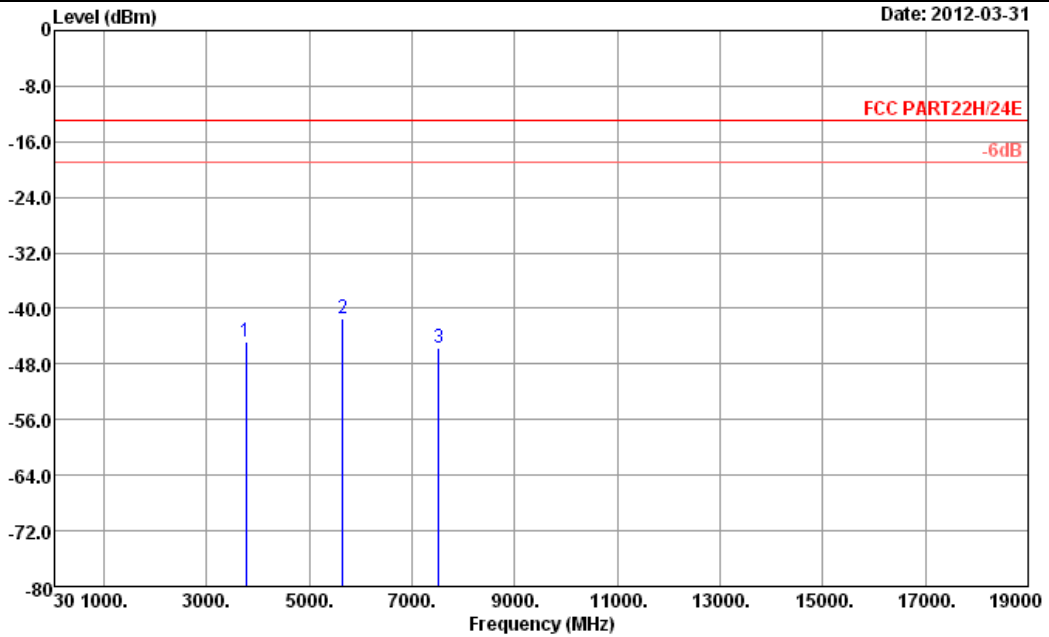

Site : 03CH05-HY
 Condition : FCC PART22H/24E HF_EIRP_101221 HORIZONTAL
 Project : FG 1D0814

Frequency (MHz)	EIRP (dBm)	Limit (dBm)	Over Limit (dB)	SPA Reading (dBm)	S.G. Power (dBm)	TX Cable loss (dB)	TX Antenna Gain (dBi)	Polarization (H/V)	Result
3760	-44.77	-13	-31.77	-57.89	-50.9	2.9292	9.06	H	Pass
5640	-41.39	-13	-28.39	-59.83	-48.31	3.9072	10.83	H	Pass
7520	-45.60	-13	-32.60	-66.92	-53.62	4.5988	12.62	H	Pass



Band :	WCDMA Band II	Temperature :	23~24°C
Test Mode :	RMC 12.2Kbps Link	Relative Humidity :	45~47%
Test Engineer :	David Ke and Kai Wang	Polarization :	Vertical
Remark :	Spurious emissions within 30-1000MHz were found more than 20dB below limit line.		

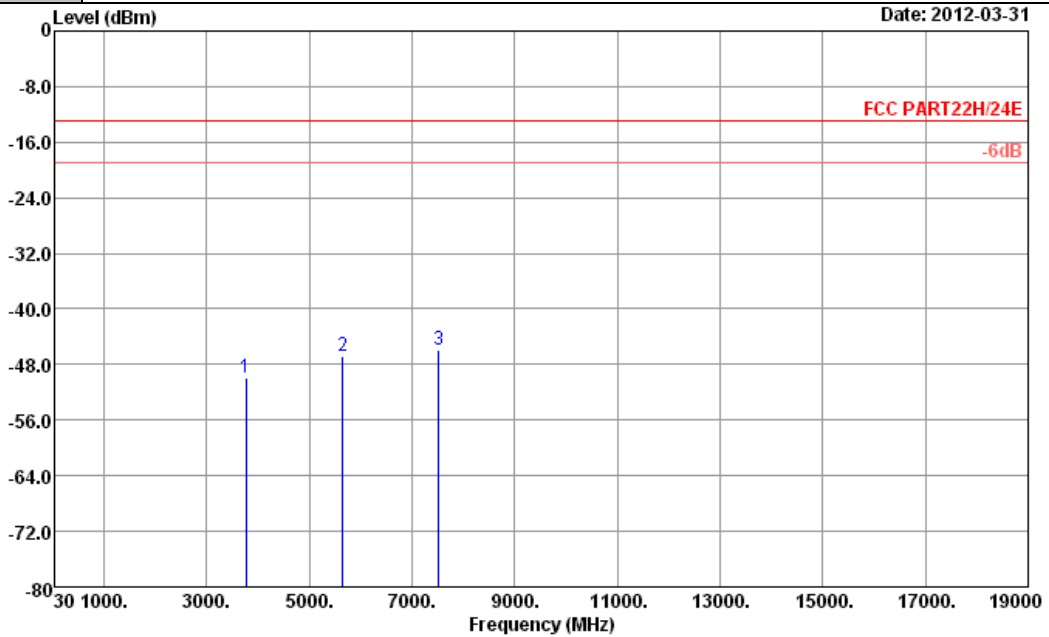

Site : 03CH05-HY
 Condition : FCC PART22H/24E HF_EIRP_101221 VERTICAL
 Project : FG 1D0814

Frequency (MHz)	EIRP (dBm)	Limit (dBm)	Over Limit (dB)	SPA Reading (dBm)	S.G. Power (dBm)	TX Cable loss (dB)	TX Antenna Gain (dBi)	Polarization (H/V)	Result
3760	-49.99	-13	-36.99	-63.11	-56.12	2.9292	9.06	V	Pass
5640	-46.74	-13	-33.74	-65.04	-53.66	3.9072	10.83	V	Pass
7520	-45.84	-13	-32.84	-67.5	-53.86	4.5988	12.62	V	Pass

3.7 Frequency Stability Measurement

3.7.1 Description of Frequency Stability Measurement

The frequency stability shall be measured by variation of ambient temperature and variation of primary supply voltage to ensure that the fundamental emission stays within the authorized frequency block. The frequency stability of the transmitter shall be maintained within $\pm 0.00025\%$ ($\pm 2.5\text{ppm}$) of the center frequency.

3.7.2 Measuring Instruments

See list of measuring instruments of this test report.

3.7.3 Test Procedures for Temperature Variation

1. The EUT was set up in the thermal chamber and connected with the base station.
2. With power OFF, the temperature was decreased to -30°C and the EUT was stabilized for three hours. Power was applied and the maximum change in frequency was recorded within one minute.
3. With power OFF, the temperature was raised in 10°C step up to 50°C . The EUT was stabilized at each step for at least half an hour. Power was applied and the maximum frequency change was recorded within one minute.
4. If the EUT cannot be turned on at -30°C , the testing lowest temperature will be raised in 10°C step until the EUT can be turned on.

3.7.4 Test Procedures for Voltage Variation

1. The EUT was placed in a temperature chamber at $25\pm 5^{\circ}\text{C}$ and connected with the base station.
2. The power supply voltage to the EUT was varied from BEP to 115% of the nominal value measured at the input to the EUT.
3. The variation in frequency was measured for the worst case.

3.7.5 Test Setup

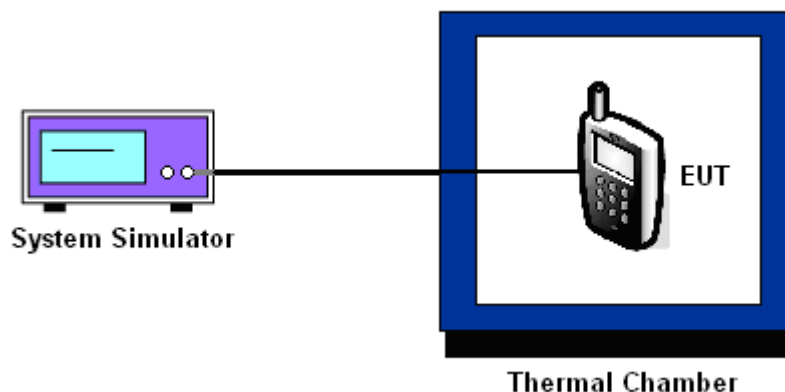

3.7.6 Test Result of Temperature Variation

Band :	GSM 850	Channel :	189		
Limit (ppm) :	2.5				
Temperature (°C)	GPRS 8		EDGE 8		Result
	Freq. Dev. (Hz)	Deviation (ppm)	Freq. Dev. (Hz)	Deviation (ppm)	
-30	N/A	N/A	N/A	N/A	PASS
-20	N/A	N/A	N/A	N/A	
-10	45	0.05	63	0.07	
0	22	0.03	43	0.05	
10	-31	-0.04	41	0.05	
20	25	0.03	39	0.05	
30	27	0.03	-46	-0.05	
40	-22	-0.03	-50	-0.06	
50	43	0.05	-46	-0.05	

Note: The manufacturer declared that the EUT could work properly between temperatures -10°C~50°C.



Band :	GSM 1900	Channel :	661
Limit (ppm) :	2.5		

Temperature (°C)	GPRS 8		EDGE 8		Result
	Freq. Dev. (Hz)	Deviation (ppm)	Freq. Dev. (Hz)	Deviation (ppm)	
-30	N/A	N/A	N/A	N/A	PASS
-20	N/A	N/A	N/A	N/A	
-10	98	0.05	119	0.06	
0	-79	-0.04	57	0.03	
10	58	0.03	45	0.02	
20	-47	-0.02	-34	-0.02	
30	42	0.02	-37	-0.02	
40	-27	-0.01	-33	-0.02	
50	-28	-0.01	-38	-0.02	

Note: The manufacturer declared that the EUT could work properly between temperatures -10°C~50°C.

Band :	WCDMA Band V	Channel :	4182
Limit (ppm) :	2.5		

Temperature (°C)	RMC 12.2Kbps		Result
	Freq. Dev. (Hz)	Deviation (ppm)	
-30	N/A	N/A	PASS
-20	N/A	N/A	
-10	31	0.04	
0	-22	-0.03	
10	-28	-0.03	
20	27	0.03	
30	20	0.02	
40	22	0.03	
50	26	0.03	

Note: The manufacturer declared that the EUT could work properly between temperatures -10°C~50°C.



Band :	WCDMA Band IV	Channel :	1413
Limit (ppm) :	2.5		

Temperature (°C)	RMC 12.2Kbps		Result
	Freq. Dev. (Hz)	Deviation (ppm)	
-30	N/A	N/A	PASS
-20	N/A	N/A	
-10	-41	-0.02	
0	-43	-0.03	
10	-37	-0.02	
20	-35	-0.02	
30	-42	-0.02	
40	-33	-0.02	
50	34	0.02	

Note: The manufacturer declared that the EUT could work properly between temperatures -10°C~50°C.

Band :	WCDMA Band II	Channel :	9400
Limit (ppm) :	2.5		

Temperature (°C)	RMC 12.2Kbps		Result
	Freq. Dev. (Hz)	Deviation (ppm)	
-30	N/A	N/A	PASS
-20	N/A	N/A	
-10	-43	-0.02	
0	-41	-0.02	
10	-34	-0.02	
20	-36	-0.02	
30	-44	-0.02	
40	-37	-0.02	
50	37	0.02	

Note: The manufacturer declared that the EUT could work properly between temperatures -10°C~50°C.



3.7.7 Test Result of Voltage Variation

Band & Channel	Mode	Voltage (Volt)	Freq. Dev. (Hz)	Deviation (ppm)	Limit (ppm)	Result
GSM 850 CH189	GPRS 8	3.7	-30	-0.04	2.5	PASS
		BEP	-21	-0.02		
		4.2	-41	-0.05		
	EDGE 8	3.7	-41	-0.05		
		BEP	-46	-0.05		
		4.2	31	0.04		
GSM 1900 CH661	GPRS 8	3.7	38	0.02		
		BEP	42	0.02		
		4.2	43	0.02		
	EDGE 8	3.7	64	0.03		
		BEP	61	0.03		
		4.2	60	0.03		
WCDMA Band V CH4182	RMC 12.2Kbps	3.7	-28	-0.03		
		BEP	-26	-0.03		
		4.2	-29	-0.03		
WCDMA Band IV CH1413	RMC 12.2Kbps	3.7	33	0.02		
		BEP	36	0.02		
		4.2	-23	-0.01		
WCDMA Band II CH9400	RMC 12.2Kbps	3.7	39	0.02		
		BEP	-34	-0.02		
		4.2	31	0.02		

Note:

1. Normal Voltage = 3.7V.
2. Battery End Point (BEP) = 3.4 V.



4 List of Measuring Equipments

Instrument	Manufacturer	Model No.	Serial No.	Characteristics	Calibration Date	Test Date	Due Date	Remark
System Simulator	R&S	CMU200	117995	N/A	Jul. 28, 2011	Mar. 28, 2012~ Apr. 02, 2012	Jul. 27, 2012	Conducted (TH02-HY)
Spectrum Analyzer	R&S	FSP40	100055	9kHz~40GHz	Jun. 13, 2011	Mar. 28, 2012~ Apr. 02, 2012	Jun. 12, 2012	Conducted (TH02-HY)
Thermal Chamber	Ten Billion	TTH-D35P	TBN-930701	N/A	Jul. 27, 2011	Mar. 28, 2012~ Apr. 02, 2012	Jul. 26, 2012	Conducted (TH02-HY)
Spectrum Analyzer	R&S	ESU26	100390	20Hz ~ 26.5GHz	Dec. 22, 2011	Mar. 20, 2012~ Mar. 31, 2012	Dec. 21, 2012	Radiation (03CH05-HY)
COM-POWER	COM-POWER	PA-103	161075	10Hz~1000MHz	Feb. 27, 2012	Mar. 20, 2012~ Mar. 31, 2012	Feb. 26, 2013	Radiation (03CH05-HY)
Bilog Antenna	SCHAFFNER	CBL6111C	2725	30MHz ~ 2GHz	Oct. 22, 2011	Mar. 20, 2012~ Mar. 31, 2012	Oct. 21, 2012	Radiation (03CH05-HY)
Turn Table	HD	Deis HD 2000	420/611	0 ~ 360 degree	N/A	Mar. 20, 2012~ Mar. 31, 2012	N/A	Radiation (03CH05-HY)
Antenna Mast	HD	MA 240	240/666	1 m ~ 4 m	N/A	Mar. 20, 2012~ Mar. 31, 2012	N/A	Radiation (03CH05-HY)
Horn Antenna	ESCO	3117	66584	1GHz ~ 18GHz	Aug. 04, 2011	Mar. 20, 2012~ Mar. 31, 2012	Aug. 03, 2012	Radiation (03CH05-HY)
Pre Amplifier	COM-POWER	PA-103	161075	10Hz ~ 1000MHz Gain:32dB	Feb. 27, 2012	Mar. 20, 2012~ Mar. 31, 2012	Feb. 26, 2013	Radiation (03CH05-HY)
Pre Amplifier	EMCI	EMC051845	SN980048	1GHz~18GHz	Jul. 18, 2011	Mar. 20, 2012~ Mar. 31, 2012	Jul. 17, 2012	Radiation (03CH05-HY)
Pre Amplifier	Agilent	8449B	3008A01917	1GHz~26.5GHz	Aug. 30, 2011	Mar. 20, 2012~ Mar. 31, 2012	Aug. 29, 2012	Radiation (03CH05-HY)
Loop Antenna	R&S	HFH2-Z2	860004/001	9 kHz~30 MHz	Jul. 29, 2010	Mar. 20, 2012~ Mar. 31, 2012	Jul. 28, 2012	Radiation (03CH05-HY)
System Simulator	R&S	CMU200	117591	N/A	Oct. 21, 2011	Mar. 20, 2012~ Mar. 31, 2012	Oct. 20, 2012	Radiation (03CH05-HY)

5 Uncertainty of Evaluation

Uncertainty of Radiated Emission Measurement (30 MHz ~ 1000 MHz)

Contribution	Uncertainty of X_i		$u(X_i)$
	dB	Probability Distribution	
Receiver Reading	0.41	Normal (k=2)	0.21
Antenna Factor Calibration	0.83	Normal (k=2)	0.42
Cable Loss Calibration	0.25	Normal (k=2)	0.13
Pre-Amplifier Gain Calibration	0.27	Normal (k=2)	0.14
RCV/SPA Specification	2.50	Rectangular	0.72
Antenna Factor Interpolation for Frequency	1.00	Rectangular	0.29
Site Imperfection	1.43	Rectangular	0.83
Mismatch	+0.39 / -0.41	U-Shape	0.28
Combined Standard Uncertainty $U_c(y)$	1.27		
Measuring Uncertainty for a Level of Confidence of 95% ($U = 2U_c(y)$)	2.54		

Uncertainty of Radiated Emission Measurement (1 GHz ~ 40 GHz)

Contribution	Uncertainty of X_i		$u(X_i)$	C_i	$C_i * u(X_i)$
	dB	Probability Distribution			
Receiver Reading	± 0.10	Normal (k=2)	0.10	1	0.10
Antenna Factor Calibration	± 1.70	Normal (k=2)	0.85	1	0.85
Cable Loss Calibration	± 0.50	Normal (k=2)	0.25	1	0.25
Receiver Correction	± 2.00	Rectangular	1.15	1	1.15
Antenna Factor Directional	± 1.50	Rectangular	0.87	1	0.87
Site Imperfection	± 2.80	Triangular	1.14	1	1.14
Mismatch Receiver VSWR $\Gamma_1 = 0.197$ Antenna VSWR $\Gamma_2 = 0.194$ Uncertainty = $20\text{Log}(1-\Gamma_1*\Gamma_2)$	+0.34 / -0.35	U-Shape	0.244	1	0.244
Combined Standard Uncertainty $U_c(y)$	2.36				
Measuring Uncertainty for a Level of Confidence of 95% ($U = 2U_c(y)$)	4.72				



Appendix A. Photographs of EUT

Please refer to Sporton report number EP1D0814 as below.