



# MORPHORAPID QUICK USER'S GUIDE

## 1. MorphoRapid™ Specifications

Technical Specifications	
Display	<ul style="list-style-type: none"> <li>• Size: 3.7"</li> <li>• VGA Display: 640 x 480 high resolution LCD Touch Panel</li> <li>• 65536 Full-Colors</li> </ul>
Sensor	<ul style="list-style-type: none"> <li>• 500 DPI in X and Y axis</li> <li>• 8-bit gray scale</li> <li>• Acquisition area 21 x 21 mm (0,8 x 0,8 ")</li> </ul>
Input/Output	USB 2.0
Power	PSA 15R-050P Model - Input: AC 100-240 V~ 50-60 Hz 0.5 A - Output: DC 5.0 V  3.0 A
Temperature Range	<ul style="list-style-type: none"> <li>• Operating +0°C to 45°C</li> <li>• Storage -20°C to 70°C</li> </ul>
Humidity	<ul style="list-style-type: none"> <li>• Operating 15% &lt; RH &lt; 95% non-condensing</li> <li>• Storage &lt; 95%</li> </ul>
Weight	800 g
Dimensions	89 x 126 x 185 mm

**NOTE** *A removable power cord connects the MorphoRapid™ to the mains supply - Its socket-outlet shall be near the MorphoRapid™ and shall be easily accessible.*

## 2. International Standards

The MorphoRapid™ terminal complies with both European and U.S. standards as follows:

Region	Standards
Europe	EMC Directive 89/336/EEC: EN55022 (1994) / EN55024 (1998) Low voltage Directive 73/23/EEC amended by 93/68/EEC: EN60950 (2000)
USA	FCC part 15 Class A digital device requirements

### USA

This device complies with part 15 of the FCC Rules. Operation is subject to the following two conditions: (1) This device may not cause harmful interference, and (2) this device must accept any interference received, including interference that may cause undesired operation.

This equipment has been tested and found to comply with the limits for a Class A digital device, pursuant to part 15 of the FCC Rules. These limits are designed to provide reasonable protection against harmful interference when the equipment is operated in a commercial environment. This equipment generates, uses and can radiate radio frequency energy and, if not installed and used in accordance with the instruction manual, may cause harmful interference to radio communications. Operation of this equipment in a residential area is likely to cause harmful interference in which case the user will be required to correct the interference at his own expense.

#### **Radiation Exposure Compliance**

This product complies with the FCC RF exposure limits for an uncontrolled environment. For continued compliance, the product must not be held closer than 20 cm from the rest of the body. This product must not be used in a holster or on a belt-clip.'

This transmitter must not be co-located or operating in conjunction with any other antenna or transmitter.

#### **WARNING**

*Changes or modifications not expressly approved by the party responsible for the compliance could void the user's authority to operate the equipment.*

### Canada

This Class A digital apparatus meets all requirements of the Canadian Interference-Causing Equipment Regulations. When using the 802.11 radio option, to prevent radio interference, this device is intended to be operated indoors and away from windows to provide maximum shielding. Equipment (or its transmit antenna) that is installed outdoors is subject to licensing.

Cet appareil numérique de la classe A respecte toutes les exigences du Règlement sur le matériel brouilleur du Canada. En cas d'utilisation du module radio 802.11, afin d'éviter toute interférence radio avec le service autorisé, l'appareil doit être utilisé à l'intérieur, tout en étant éloigné de toute fenêtre afin de garantir le maximum de protection. Si cet équipement (ou son antenne émettrice) est installé à l'extérieur, il est alors soumis à licence.

Model	Option
Morpho RapID 1100	Standard version
Morpho RapID 1100 W	WiFi
Morpho RapID 1100 G	GSM/GPRS/3G
Morpho RapID 1100 WG	WiFi - GSM/GPRS/3G

### 3.Cleaning

Clean the MorphoRapid™ body, screen and biometric sensor with a dry, non-abrasive, lint-free cloth and only with a cleaning product recommended by Sagem Sécurité.

During periods of intense activity, the sensor should be cleaned as soon as smears are visible on-screen.



**WARNING**

***Avoid using any alcohol or by-products that could damage the MorphoRapid™ body or sensor part (cracks may appear on body or prism).***

*Examples of corrosive chemicals to be avoided:*

- acetone,
- ammoniac,
- benzene,
- ethanol,
- methanol,
- methylated spirit,
- petrol,
- thichlorethylene.

## 4. Battery

### Precautions

#### Battery Handling



The battery handling precautions for MorphoRapid™ batteries are:

#### WARNING

- The battery used in this device may present a fire or chemical burn hazard if mistreated.
- Do not disassemble, heat above 100°C (212°F) or incinerate.
- Never short-circuit the pack. It may cause electrolyte leakage, gazing or fire.
- Avoid all risk of short-circuit when handling the batteries or during storage.
- Leakage under conditions of intended use and reasonably foreseeable misuse shall not occur. Even so if electrolyte leaks out of the pack and comes into contact with the skin, eyes or others parts of body, the electrolyte should be flushed immediately with fresh water. Seek medical advice from a physician.
- Never incinerate nor dispose of pack into fire.
- The pack should never be soaked in liquid.
- If any abnormal features of the pack are found such as: damage to the plastic envelope, deformation of the pack, smell of electrolyte, electrolyte leakage, or other abnormalities, the cell should not be used anymore.

#### Battery Replacement

The battery replacement precautions are (see Battery Replacement):

#### WARNING

- Danger of explosion if battery is incorrectly replaced.*
- Replace only with the same battery type.*
- Must be disposed of properly.*

### Battery Transportation

It is recommended to remove batteries from the terminal when the product is transported on long distance.

### Battery Charge

It is mandatory to only use the battery charger delivered by Sagem Sécurité for the MorphoRapid™ product for MorphoRapid™ battery charge.

The battery pack should be charged within the range of specified temperatures. If the pack is charged at a temperature out of the specified range, leakage, heat generation, or other damages may occur.

The battery pack should be discharged within the range of specified temperatures.

**NOTE** *Do not use MorphoRapid™ batteries for any other use than the MorphoRapid™ product.*

It should be noted that the battery pack may be overdischarged if the pack is not used for a long time. In order to prevent overdischarging, the pack should be charged periodically. Overdischarging may cause loss of pack performance, or damage battery functions.

So as to keep a correct autonomy, it is recommended to regularly perform complete charge/discharge cycles.

**WARNING** *To switch the terminal off for a period of storage longer than 7 days, it is advised to disconnect the battery.*

*In the same way, to preserve battery life during a long period of storage, it is advised to disconnect or to remove the battery with a minimum charge of 30% of battery capacity and not in deep discharge (0%).*

### Power Supply Precautions

The installation and maintenance of the MorphoRapid™ should be made by a qualified service person and should conform to all local codes.

Before plugging the power source to your MorphoRapid™, check that the power source you intend to connect do complies with the voltage, current and frequency specifications on the rating label on the power supply unit.

**NOTE** *Use only the power supply unit provided with your MorphoRapid™.*

## Battery Replacement

Here are the instructions to replace the battery:

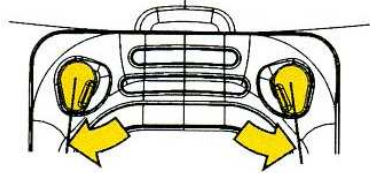
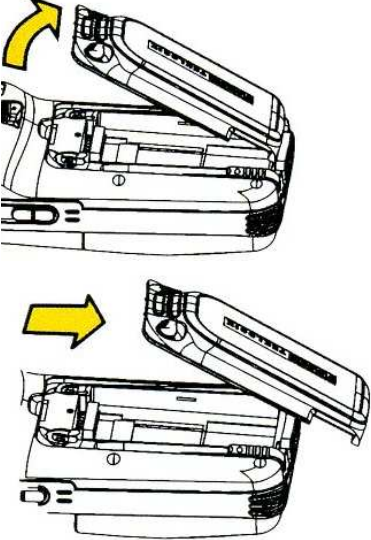
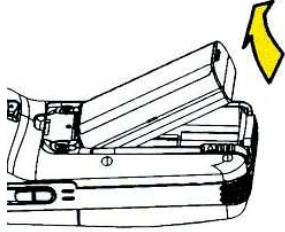
Screen	Action
	1 At the back of the device, unlatch the battery cover latches.
	2 Open the battery compartment by pulling and sliding its cover.
	3 Take the discharged battery off its compartment.

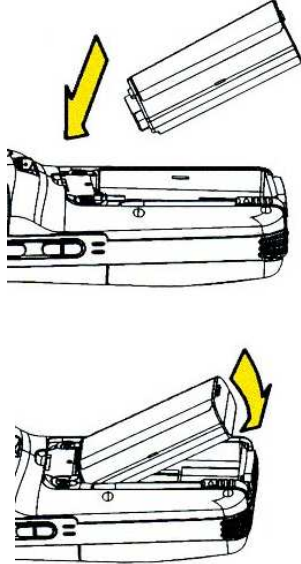
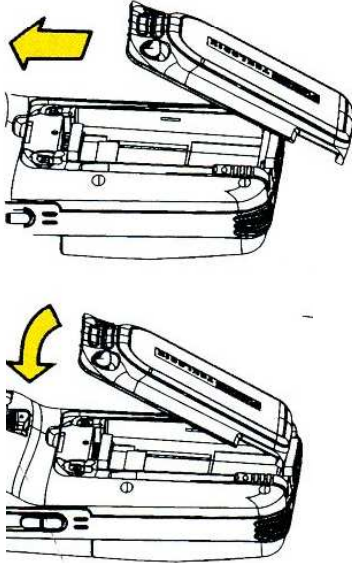
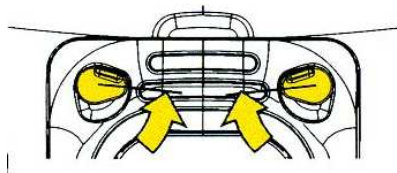





Screen	Action
 <p>The diagram consists of two parts. The top part shows a battery being lowered into the open battery compartment, with a yellow arrow pointing downwards. The bottom part shows the battery fully seated in the compartment, with a yellow arrow pointing upwards from the top of the battery, indicating the next step in the process.</p>	<p>4 Replace the discharged battery by the charged one: insert the new battery.</p>
 <p>The diagram consists of two parts. The top part shows the battery compartment cover being pushed back into its closed position, with a yellow arrow pointing to the left. The bottom part shows the cover fully closed, with a yellow arrow pointing downwards from the top edge of the cover.</p>	<p>5 Close the battery compartment.</p>
 <p>The diagram shows a top-down view of the battery compartment. Two yellow arrows point towards the center of the compartment, indicating the latching mechanism.</p>	<p>6 Latch the battery compartment.</p>



## Battery Level Management



### Battery Icon

The battery level is shown as a battery icon at the bottom of MAIN MENU.  
The battery levels are detailed in the following table:

Icon	Battery	MorphoRapID™ Use
	Full	optimal
	Good	optimal
	Medium	optimal
	Low	works properly but should be charged soon
	Empty	must be charged
	<b>WARNING</b>	The fingerprint sensor may not be usable and captured data accuracy is no longer guaranteed.
	Terminal connected to the mains and charging	

### Battery Level Battery Level Percentage Check

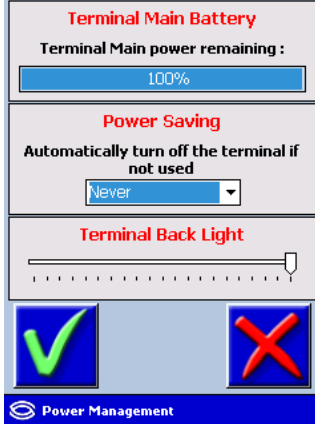
To check the battery level, proceed as follows:

Screen	Action
	<ol style="list-style-type: none"> <li>1 Start the MorphoRapid™ terminal.</li> <li>2 Press, SETTINGS then POWER.</li> <li>3 Check the battery level. → Proceed to charging the battery if needed.</li> </ol>
	<ol style="list-style-type: none"> <li>4 Click  to go back to the MAIN MENU.</li> </ol>

## Power Management

### Description

POWER MANAGEMENT provides a means of:

- knowing battery power level,
- setting power saving,
- setting terminal back light.

#### NOTE

*The terminal backlight setting can also be accessed by clicking on the Sagem Sécurité logo at the bottom left corner of the screen.*

#### NOTE

*The terminal backlight setting can also be accessed by pressing twice the*

*Orange key and then the ESC key* 

**◆ Press the key as many times as needed to adjust backlight.**

## 5. Recommendations

### General Precautions

#### WARNING

*The manufacturer cannot be held responsible if the above recommendations are not followed or if the Sagem Sécurité MorphoRapid™ is used incorrectly.*

- *Do not attempt to repair your Sagem Sécurité MorphoRapid™ yourself. The manufacturer cannot be held responsible for any damage/accident that may result from attempts to repair components.*
- *Any work carried out by non-authorized personnel will invalidate your warranty.*
- *Do not expose your Sagem Sécurité MorphoRapid™ to extreme temperatures.*
- *Attempts to integrate the MorphoRapid™ with unapproved accessories will void your warranty.*

*The MorphoRapid™ is not waterproof. Do not attempt to immerse*



*it.*

### Areas Containing Combustibles

It is strongly recommended not to install the Sagem Sécurité MorphoRapid™ in the vicinity of gas stations, petroleum processing facilities or any other facility containing flammable or combustible gas or materials.