

TABLE OF CONTENTS

1 GENERAL INFORMATION

1.1	SCOPE OF MANUAL	1-1
1.2	EQUIPMENT DESCRIPTION	1-1
	GENERAL	1-1
	DM3474 SYNTHESIZER PROGRAMMING	1-1
1.3	TRANSCEIVER IDENTIFICATION	1-1
1.4	PART NUMBER BREAKDOWN	1-1
1.5	ACCESSORIES	1-1
1.6	FACTORY CUSTOMER SERVICE	1-1
1.7	PRODUCT WARRANTY	1-2
1.8	REPLACEMENT PARTS	1-2
1.9	FACTORY RETURNS	1-2

2 INSTALLATION

2.1	PRE-INSTALLATION CHECKS	2-1
2.2	INTERFACING WITH DATA EQUIPMENT	2-1
	DM3474 ONLY	2-1

3 PROGRAMMING

3.1	INTRODUCTION	3-1
3.2	DM3474 SYNTHESIZER DATA PROTOCOL	3-1
	D-WORD	3-1
	B-WORD	3-1
	A-WORD	3-1
3.3	RECEIVE TO TRANSMIT SEQUENCE	3-4
3.4	TRANSMIT TO RECEIVE SEQUENCE	3-4

4 CIRCUIT DESCRIPTION

4.1	GENERAL	4-1
	INTRODUCTION	4-1
	SYNTHESIZER	4-1
	RECEIVER	4-1
	TRANSMITTER	4-1
4.2	SYNTHESIZER	4-1
	INTRODUCTION	4-1
	VOLTAGE-CONTROLLED OSCILLATOR	4-3
	VCO AND REFERENCE OSCILLATOR MODULATION	4-4
	CASCADE AMPLIFIERS (Q851/Q852)	4-4
	AMPLIFIER (Q853)	4-4
	VOLTAGE FILTER (Q832)	4-4
	VCO FREQUENCY SHIFT (Q831)	4-4
	SYNTHESIZER INTEGRATED CIRCUIT (U801)	4-5
	LOCK DETECT	4-5
4.3	RECEIVER CIRCUIT DESCRIPTION	4-5
	HELICAL FILTER (Z201), RF AMPLIFIER (Q201)	4-5
	MIXER (U221), FIRST LO AMPLIFIER (Q301)	4-6
	AMPLIFIER (Q222), CRYSTAL FILTER (Z221/Z222), IF AMP (Q221)	4-6
	SECOND LO AMP/TRIPLER (Q401), SECOND IF FILTER (Q901)	4-6

TABLE OF CONTENTS

	SECOND MIXER/DETECTOR (U241)	4-6
4.4	TRANSMITTER CIRCUIT DESCRIPTION	4-7
	BUFFER (Q851)	4-7
	PRE-DRIVER (Q501), DRIVER (Q521)	4-7
	-5V POWER CONTROL SUPPLY	4-7
	FINAL (Q541), POWER CONTROL (U542)	4-7
	ANTENNA SWITCH (CR561, CR562)	4-8
5	SERVICING	
5.1	GENERAL	5-1
	PERIODIC CHECKS	5-1
	SURFACE-MOUNTED COMPONENTS	5-1
	SCHEMATIC DIAGRAMS AND COMPONENT LAYOUTS	5-1
	REPLACEMENT PARTS LIST	5-1
	TCXO MODULE NOT SERVICEABLE	5-1
5.2	SYNTHESIZER SERVICING	5-1
	INTRODUCTION	5-1
	REFERENCE OSCILLATOR	5-1
	VCO	5-1
	SYNTHESIZER (U801)	5-2
5.3	RECEIVER SERVICING	5-2
	SUPPLY VOLTAGES AND CURRENT	5-2
	MIXER/DETECTOR (U201)	5-2
	RF AMPLIFIER (Q201) AND FIRST MIXER (Q221)	5-3
	RF AND IF AMPLIFIERS, FIRST MIXER	5-3
5.4	TRANSMITTER SERVICING	5-3
	SUPPLY VOLTAGES AND CURRENT	5-3
6	ALIGNMENT PROCEDURE AND PERFORMANCE TESTS	
6.1	GENERAL	6-1
6.2	DL3474 TRANSCEIVER ONLY	6-1
	FREQUENCY AND CONTROL LINE VOLTAGE CHECK	6-1
	2W TRANSMITTER POWER ALIGNMENT	6-1
	LOW POWER ALIGNMENT	6-2
	MODULATION FLATNESS ALIGNMENT	6-2
	RECEIVER ALIGNMENT	6-2
	IF AND AUDIO ADJUSTMENTS	6-3
7	PARTS LIST	
8	SCHEMATICS AND COMPONENT LAYOUTS	
	VCO COMPONENT LAYOUT	8-1
	TRANSCEIVER COMPONENT LAYOUTS	8-2
	TRANSCEIVER SCHEMATIC	8-3

LIST OF FIGURES

2-1	DM3474 INTERFACE CABLE	2-2
3-1	D-WORD	3-2
3-2	B-WORD	3-2
3-3	A-WORD	3-3
3-4	SERIAL INPUT WORD FORMAT	3-3
3-5	RX TO TX TIMING DIAGRAM	3-4
3-6	TX TO RX TIMING DIAGRAM	3-4
4-1	DATA TRANSCEIVER BLOCK DIAGRAM	4-2
4-2	U801 SYNTHESIZER BLOCK DIAGRAM	4-3
4-3	U241 BLOCK DIAGRAM	4-6
5-1	RECEIVER SERVICING FLOWCHART	5-2
5-2	TRANSMITTER SERVICING FLOWCHART	5-3
6-1	TRANSMITTER TEST SETUP	6-1
6-2	RECEIVER TEST SETUP	6-2
6-3	ALIGNMENT POINTS DIAGRAM	6-4
8-1	VCO COMPONENT LAYOUT (COMPONENT SIDE VIEW)	8-1
8-2	TRANSCEIVER COMPONENT LAYOUT (COMPONENT SIDE VIEW)	8-2
8-3	TRANSCEIVER COMPONENT LAYOUT (OPPOSITE COMPONENT SIDE VIEW)	8-2
8-4	TRANSCEIVER SCHEMATIC	8-3

LIST OF TABLES

1-1	ACCESSORIES	1-1
-----	-------------------	-----

(

.

.

(

.

.

(

The following are general specifications intended for use in testing and servicing this transceiver. For current advertised specifications, refer to the specification sheet available from the Marketing Department. Specifications are subject to change without notice.

GENERAL

Frequency Range	403-512 MHz
Frequency Control	Synthesized
Channel Spacing	12.5/20/25 kHz
Mode of Operation	Simplex or Half Duplex
Operating Voltage	+7.5V DC \pm 10%
Regulated Supply Voltages	+5V DC \pm 5%
RF Input/Output	MCX Jack
Power and Data Interface	14-pin in-line socket, 100 mil center
Operating Temperature	-30° to +60° C (-22° to +140° F)
Maximum Dimensions	2.83" L (7.19 cm), 2.19" W (5.56 cm), 0.64" H (1.70 cm)
Weight (w/o Loader Bd)	2.3 oz (65 g)
FCC Compliance	DM3474 customer must apply

RECEIVER

Bandwidth	16 MHz
Frequency Stability	\pm 1.5 PPM
Sensitivity - 12 dB SINAD	0.45 μ V
RF Input Impedance	50 ohms
Selectivity	-70 dB
Spurious and Image Rejection	-60 dB (12.5 kHz), -70 dB (20/25 kHz)
Intermodulation	-70 dB
FM Hum and Noise	-40 dB (12.5 kHz), -45 dB (20/25 kHz)
Conducted Spurious	-57 dBm
Receive Current Drain	< 70 mA nominal
Receive Attack Time	< 7 ms (dependent on synthesizer loading implementation)
Audio	
Distortion	< 3%
Output Level DM3474	600-1200 mV P-P or 200-400 mV RMS (1 kHz at \pm 3 kHz)
Response	
DM3474	\pm 2 dB from DC to 5 kHz (reference to 1 kHz)
Minimum Load Impedance	1k ohms

TRANSMITTER

Bandwidth	16 MHz
Frequency Stability	\pm 1.5 PPM
TCXO Coupling	DC
RF Power Output	2W nominal adjustable to 500 mW (-XX0) 500 mW nominal adjustable to 75 mW (with Low Power Kit)
RF Output Impedance	50 ohms
Modulation Distortion	< 3%
Duty Cycle	50%, 60 seconds maximum transmit
Transmitter Attack Time	< 7 ms (dependent on synthesizer implementation)
Spurious and Harmonic FM	-37 dBm
FM Hum and Noise	-40 dB 12.5 kHz, -45 dB 25 kHz
Audio Response	\pm 1.5 dB from DC to 5 kHz (reference to 1 kHz) Programmable to \pm 1 dB at the RF band edges via J201, pin 14.
Data Input Impedance	100k ohm
Modulation Response	\pm 1 dB from DC to 5 kHz (reference to 1 kHz)
Current Drain	< 800 mA at 2W, +7.5V DC

This page intentionally left blank.

SECTION 2 INSTALLATION

2.1 PRE-INSTALLATION CHECKS

Field alignment should not be required before the 3474 is installed. However, it is still good practice to check the performance to ensure that no damage occurred during shipment. Performance tests are located in Section 6.2.

2.2 INTERFACING WITH DATA EQUIPMENT

2.2.1 DM3474 ONLY

Connector J201 on the data transceiver PC board provides the interface with the data equipment. This is a 14-pin female connector with .025" square pins on 0.1" centers (Dupont 76308-114). An interface cable diagram and pin designations are shown in Figure 2-1. This cable is not included with the data transceiver.

The following is a general description of the various J201 input and output signals.

Pin 1 (Ground) - Chassis ground.

Pin 2 (+7.5V DC Continuous) - This voltage should be stabilized near +7.5V DC. Variations from +6V to +9V can change power output as much as 6 dB.

Pin 3 (+7.5V DC Transmit) - This input should be +7.5V DC in transmit mode only.

Pin 4 (+5V DC Receive Control Line) - This input should be +5V DC in the receive mode only, ≤ 0.3 V DC in Tx, input impedance $\geq 10k$ ohms.

Pin 5 (+5V DC Continuous) - This voltage should be stabilized near +5V DC.

Pin 6 (Tx Input) - Provides a response of ± 1.5 dB from DC to 5 kHz. The sensitivity is approximately 7 kHz deviation per volt RMS. When this input is used, a temperature compensated 2.5V DC bias is required because variations in voltage cause the frequency to change. In addition, the transceiver regulatory compliance must be applied for with the customer supplied modulation limiting/filter circuit and chassis.

Pin 7 (Synthesizer Lock) - Output from synthesizer lock detect circuit. Low = unlocked, high = locked.

Pin 8 (Synthesizer Enable) - Latch enable signal. A rising edge on this input latches the data loaded into synthesizer IC U801.

Pin 9 (Synthesizer Data) - Serial data line used for programming synthesizer IC U801.

Pin 10 (Synthesizer Clock) - Software generated serial clock. Data is valid on the rising edge of this signal.

Pin 11 (Carrier Detect) - This output is not used at this time.

Pin 12 (RSSI Output) - The RSSI (Receive Signal Strength Indicator) output provides a voltage that increases in proportion to the strength of the RF input signal.

Pin 13 (Rx Output) - The data output level is 600-1200 millivolts P-P (200-400 mV RMS) with a modulation signal of 1 kHz at 60% of maximum deviation. The output is DC coupled and referenced to +2.5V DC. Load impedance should be 10k-100k ohms.

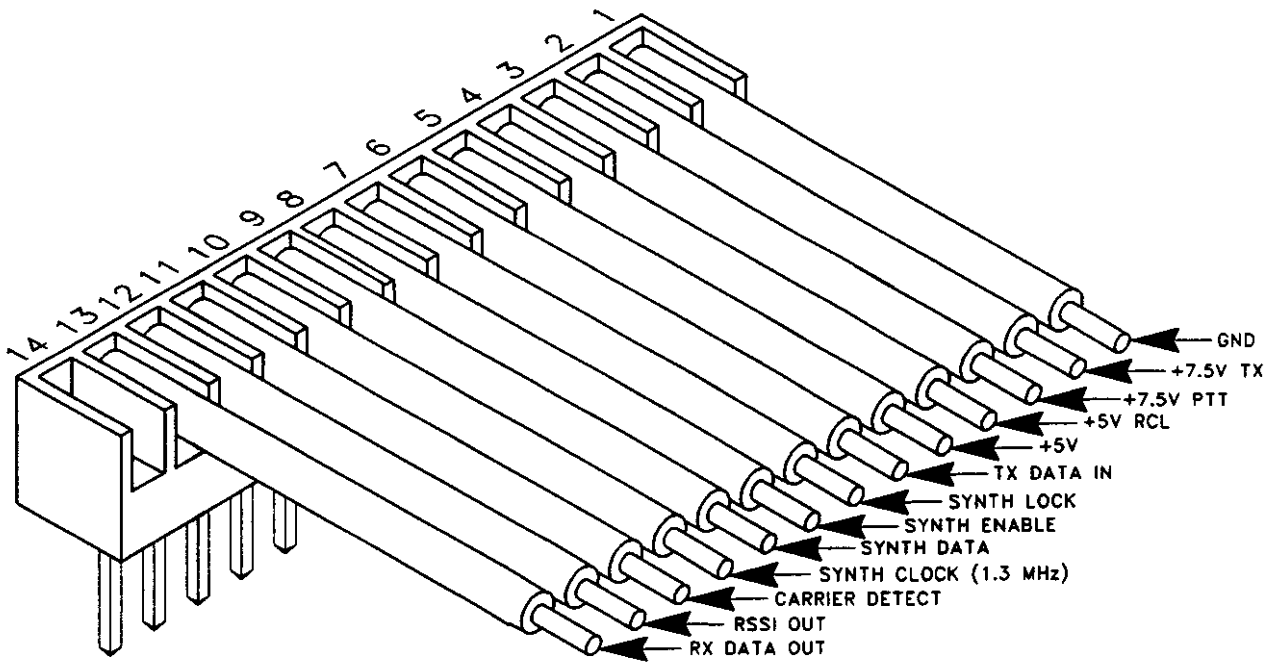

Figure 2-1 DM3474 INTERFACE CABLE

SECTION 4 CIRCUIT DESCRIPTION

4.1 GENERAL

4.1.1 INTRODUCTION

The main subassemblies of this transceiver are the RF board, VCO board, TCXO. A block diagram of the transceiver is located in Figure 4-1.

The VCO board is enclosed by a metal shield and soldered directly to the RF board. The VCO is not serviceable.

The 3474 is available with a reference oscillator stability of ± 1.5 PPM. The TCXO (Temperature Compensated Crystal Oscillator) is soldered directly to the RF board.

4.1.2 SYNTHESIZER

The VCO (voltage-controlled oscillator) output signal is the receiver first injection frequency in the Receive mode and the transmit frequency in the Transmit mode. The first injection frequency is 52.95 MHz above the receive frequency. The frequency of this oscillator is controlled by a DC voltage produced by the phase detector in synthesizer chip U801.

Channels are selected by programming counters in U801 to divide by a certain number. This programming is performed over a serial bus formed by the Synth Clock, Synth Enable, and Synth Data pins of J201. This programming is performed by user supplied hardware and software (see Section 3).

The frequency stability of the synthesizer in both the receive and transmit modes is established by the stability of the reference oscillator described in the preceding section. These oscillators are stable over a temperature range of -30° to $+60^{\circ}$ C (-22° to $+140^{\circ}$ F).

4.1.3 RECEIVER

The receiver is a double-conversion type with intermediate frequencies of 52.95 MHz / 450 kHz. Two helical bandpass filters reject the image, half IF, injection, and other unwanted frequencies. A four-pole crystal filter enhances receiver selectivity.

4.1.4 TRANSMITTER

The transmitter produces a nominal RF power output of 2W adjustable to 500 mW (-XX0) or 500 mW adjustable to 75 mW (with Low Power Kit). Frequency modulation of the transmit signal occurs in the synthesizer. Transmit audio processing circuitry is contained in the customer-supplied equipment.

4.2 SYNTHESIZER

4.2.1 INTRODUCTION

A block diagram of the synthesizer is shown in Figure 4-1 and a block diagram of Synthesizer IC U801 is shown in Figure 4-2. As stated previously, the synthesizer output signal is produced by a VCO (voltage controlled oscillator). The VCO frequency is controlled by a DC voltage produced by the phase detector in U801. The phase detector senses the phase and frequency of the two input signals and causes the VCO control voltage to increase or decrease if they are not the same. The VCO is then "locked" on frequency.

Programming of the synthesizer provides the data necessary for the internal prescaler and counters. One input signal is the reference frequency. This frequency is produced by the 17.5 MHz reference oscillator (TCXO). The other input signal is the VCO frequency.

The Fractional-N increment (NF) is a 3-bit word that is channel dependent. NF is used to program the sub-channels below the 50 kHz Loop Reference frequency. FCM = 50 kHz and if FMOD = 8, then the Fractional-N increment is: $50 \text{ kHz} \div 8 = 6.25 \text{ kHz}$

To program an 18.75 kHz channel:

$$NF = 18.75 \text{ kHz} \div 6.25 \text{ kHz}$$

$$NF = 3$$

NM1 and NM2 are calculated as follows:

$$N = (NM1 + 2) \times 64 + NM2 \times 65$$

Where:

N = total division ratio

NM1 = Number of main divider cycles when prescaler modulus equals 64
 NM2 = Number of main divider cycles when prescaler modulus equals 65

Example:

Calculate NM1 and NM2 to Receive 454.500 MHz.

$$LO = 454.5 + 52.95 = 507.45 \text{ MHz}$$

(52.95 MHz IF with High Side Injection)

$$N = RX \text{ LO} \div FCM = 507.45 \div 0.05 = 10149$$

(FCM = Loop Reference Frequency)

$$NM2 = 64 \times \text{FRAC} [N \div 64]$$

$$= 64 \times \text{FRAC} [10149 \div 64]$$

$$= 64 \times 0.57813$$

$$= 37$$

$$NM1 = \text{INTEGER} [N \div 64] - 2 - NM2$$

$$= 158 - 2 - 37$$

$$= 119$$

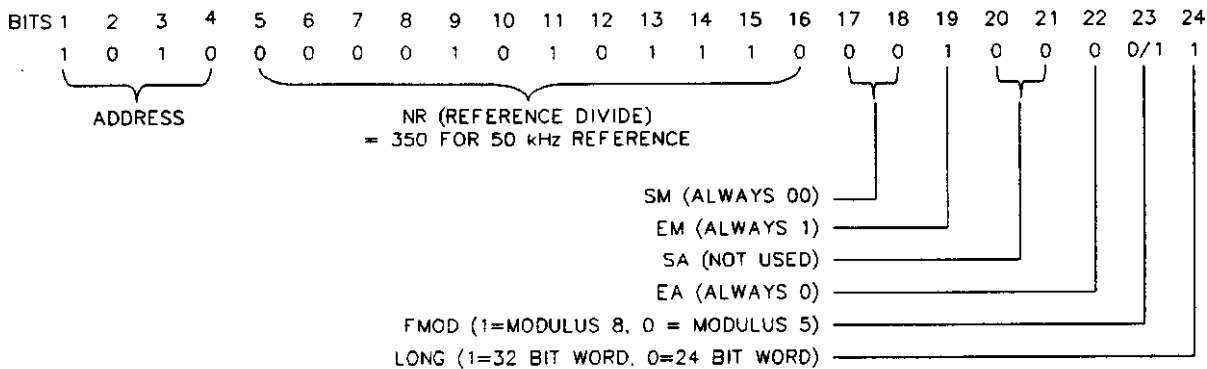

Figure 3-1 D-WORD

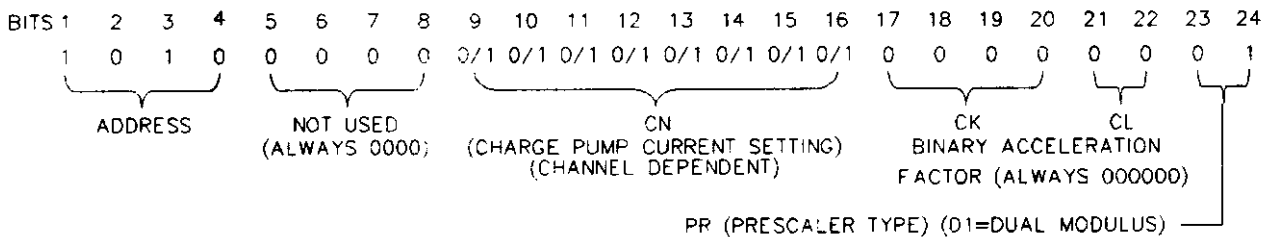

Figure 3-2 B-WORD

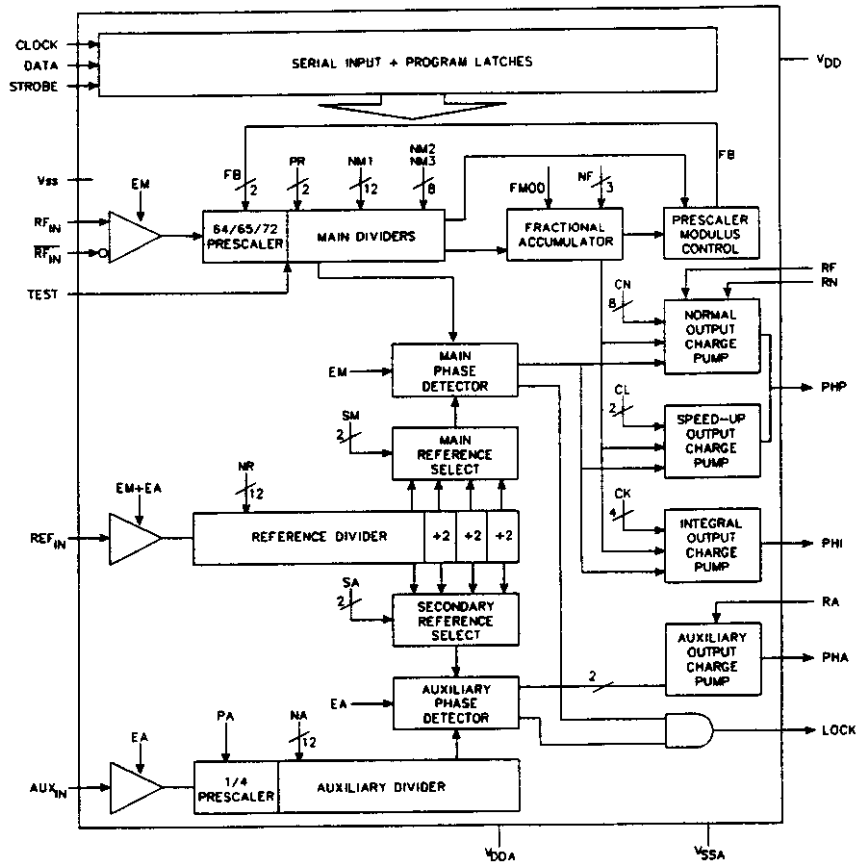

Figure 4-2 U801 SYNTHESIZER BLOCK DIAGRAM

4.2.2 VOLTAGE-CONTROLLED OSCILLATOR

Oscillator (Q850)

The VCO is formed by Q850, several capacitors and varactor diodes, and a ceramic resonator. It oscillates at the transmit frequency in transmit mode and first injection frequency in the receive mode (approximately 450 MHz in transmit and 500 MHz in receive).

Biasing of Q850 is provided by R862, R867 and R868. An AC voltage divider formed by C859, C861 and C862 initiates and maintains oscillation and also matches Q850 to the tank circuit. The ceramic resonator is grounded at one end to provide shunt inductance to the tank circuit.

Frequency Control and Modulation

The VCO frequency is controlled in part by DC voltage across varactor diodes CR854, CR855, CR856 and CR851. As voltage across a reverse-biased varactor diode increases, its capacitance decreases. Therefore, VCO frequency increases as the control voltage increases. CR854/CR855 and CR856/CR851 are paralleled varactors to divide the capacitance and improve linearity. The varactors are biased at -2V to adjust to the voltage output of U801. The control line is isolated from tank circuit RF by choke L851 and L854 and decoupling capacitor C854. The amount of frequency change produced by CR854/CR855/CR856/CR851 is controlled by series capacitor C853.

3.3 RECEIVE TO TRANSMIT SEQUENCE

Refer to Figure 3-5.

1. Synthesizer is loaded (B and A 24-Bit words or one long 32-bit A-Word).
2. The state of the SRCL line does not have to be changed until the last bit is sent. However, RX will cease as soon as it is changed.
3. The SYNTH ENABLE line should be held HIGH for 2 to 3 milliseconds after the last word is sent. This puts the frequency synthesizer in a SPEEDUP MODE and slightly improves lock times.
4. After the last word is strobed in, 7 milliseconds (worst case) should elapse before 7.5 TX is turned ON. This allows the synthesizer to come within 1 kHz of the desired frequency.

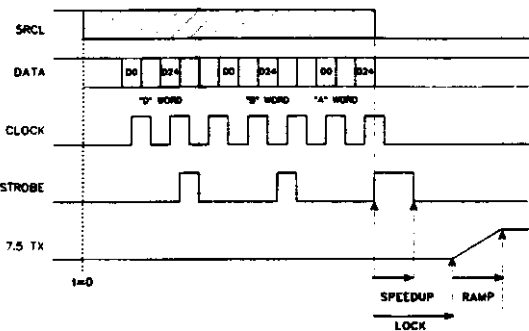

Figure 3-5 RX TO TX TIMING DIAGRAM

Dekey is a length of time to allow the TX to power down while the synthesizer is still in lock. This is needed to meet ETSI (European Telecommunications Standards Institute) adjacent power specifications. Dekey is approximately 3 ms in length. The 7.5 TX should be ramped or optimally filtered in such a way as to reduce the S_{inx}/x power spreading. Speedup will slightly improve lock times and is 1 to 2 ms.

3.4 TRANSMIT TO RECEIVE SEQUENCE

Refer to Figure 3-6.

1. 7.5 TX is turned OFF. For best TX adjacent channel power performance this could be shaped.
2. The synthesizer load process could begin slightly before, but when the last bit is strobed in the synthesizer it will become unlocked. For ETSI specs, the TX should be turned OFF "on-frequency".
3. The SRCL line should switch from low to high AFTER the 7.5 TX is switched. The SRCL not only turns the RX circuits on but also Pin Shifts the VCO.
4. For quickest lock times the SYNTH ENABLE line on the last load word should be held high for 2 to 3 milliseconds. It MUST NOT be left high as the synthesizer in the SPEEDUP mode has poor noise performance and would degrade the RX performance.

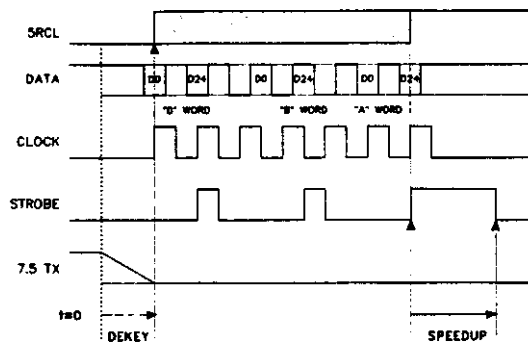

Figure 3-6 TX TO RX TIMING DIAGRAM

Speedup is 2 to 3 ms
Lock is approximately 7 ms
Ramp is approximately 3 ms

IMPORTANT

If the receiver is to be operated at 510-512 MHz (-810), a spurious condition may occur to degrade the receiver sensitivity 2 to 3 dB. If this degradation is unacceptable, the synthesizer can be reprogrammed to a comparison frequency (FCM) of 31.25 kHz (so that a multiple of this would not be 52.95 MHz) and a modulus (FMOD) of 5 with a reference divide (NR) of 560. These parameters place the spurious at harmonics of 31.25 kHz (instead of 50 kHz) outside the passband of the IF filters where the sensitivity is not degraded.

low impedance to RF; and when it is reverse biased, it presents a very high impedance. The capacitive leg is switched in when in transmit and out when in receive.

When J201, pin 4 is high in receive, Q834 is turned off, Q101 is turned on and the collector voltage goes low. A low on the base of Q102 turns the transistor on and the regulated +5.5V on the emitter is on the collector for the receive circuitry. With a low on the base of Q831 the transistor is off and the collector is high. With a high on the collector of Q831 and a low on the emitter of Q834, this reverse biases CR850 for a high impedance.

The capacitive leg is formed by C851, CR850, C852 and C876. When J201, pin 4 is low in transmit, Q834 is turned on and a high is on the emitter, Q101 is turned off and the collector voltage goes high. A high on the base of Q102 turns the transistor off and the regulated +5.5V is removed from the receive circuitry. With a high on the base of Q831 the transistor is on and the collector is low. With a low on the collector of Q831 and a high on the emitter of Q834, this forward biases CR850 and provides an RF ground through C851 and C852/C876 are effectively connected to the tank circuit. This decreases the resonant frequency of the tank circuit.

4.2.8 SYNTHESIZER INTEGRATED CIRCUIT (U801)

Introduction

Synthesizer chip U801 is shown in Figure 4-2. This device contains the following circuits: R (reference), Fractional-N, NM1 and NM2; phase and lock detectors, prescaler and counter programming circuitry. The basic operation was described in Section 4.2.1.

Channel Programming

Frequencies are selected by programming the R, Fractional-N, NM1 and NM2 in U801 to divide by a certain number. These counters are programmed by a user supplied programming circuit. More information on programming is located in Section 3.

As previously stated, the counter divide numbers are chosen so that when the VCO is oscillating on the correct frequency, the VCO-derived input to the phase detector is the same frequency as the reference oscillator-derived frequency.

The VCO frequency is divided by the internal prescaler and the main divider to produce the input to the phase detector.

4.2.9 LOCK DETECT

When the synthesizer is locked on frequency, the SYNTH LOCK output of U801, pin 18 (J201, pin 7) is a high voltage. Then when the synthesizer is unlocked, the output is a low voltage. Lock is defined as a phase difference of less than 1 cycle of the TCXO.

4.3 RECEIVER CIRCUIT DESCRIPTION

4.3.1 HELICAL FILTER (Z201), RF AMPLIFIER (Q201)

Capacitor C201 couples the receive signal from the antenna switch to helical filter Z201. (The antenna switch is described in Section 4.4.5.) Z201 is a band-pass filter tuned to pass only a narrow band of frequencies to the receiver. This attenuates the image and other unwanted frequencies. The helicals are factory set and should not be tuned.

Impedance matching between the helical filter and RF amplifier Q201 is provided by C203, C204 and L201. Q201 amplifies the receive signal to recover filter losses and also to increase receiver sensitivity. Biasing for Q201 is provided by R201, R202 and R203; and C208/C209 provide RF bypass. CR201 protects the base-emitter junction of Q201 from excessive negative voltages that may occur during high signal conditions. Additional filtering of the receive signal is provided by Z202, L202, and C205 provide impedance matching between Q201 and Z202. Resistor R204 is used to lower the Q of L202 to make it less frequency selective.

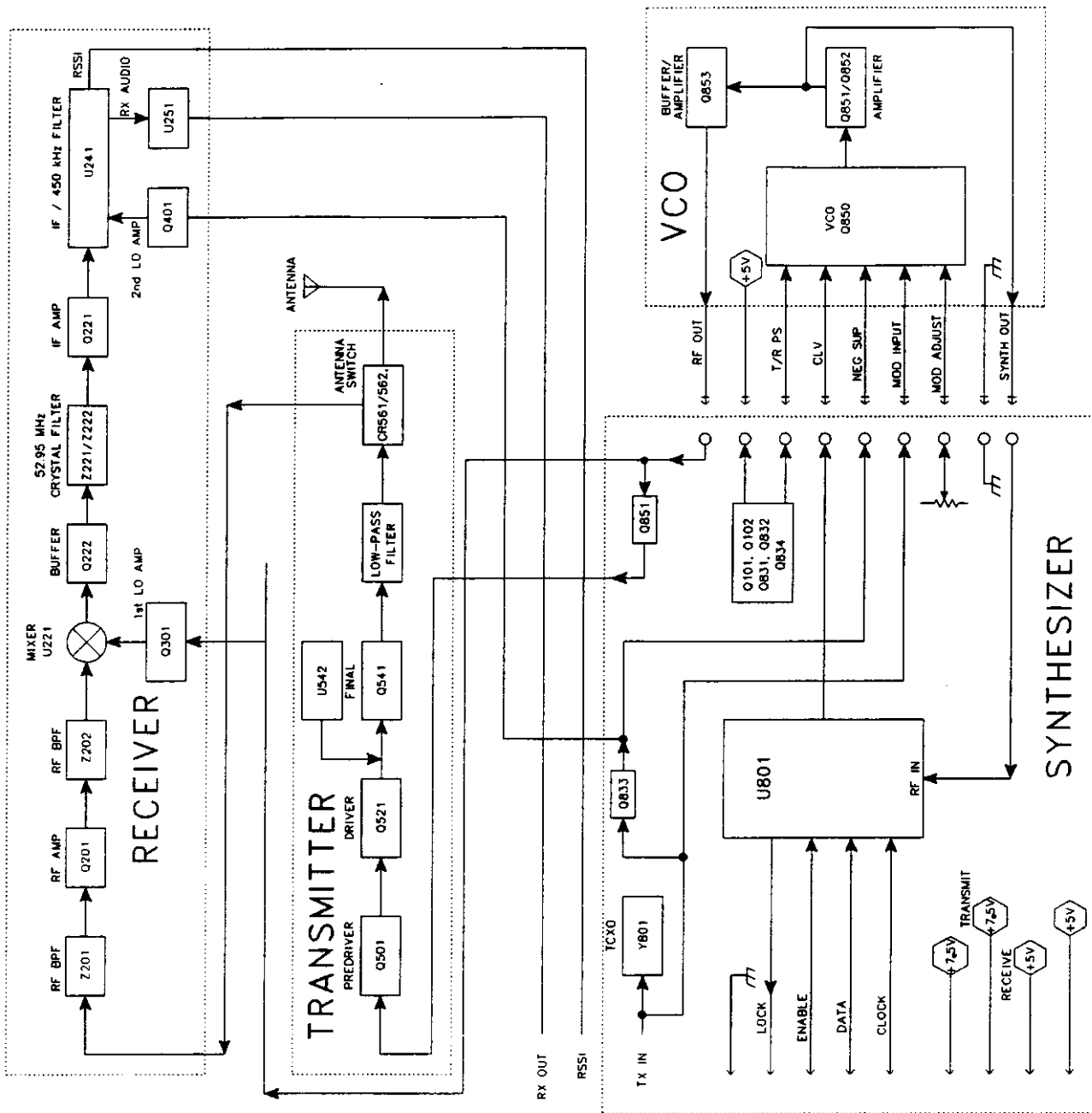

Figure 4-1 DATA TRANSCEIVER BLOCK DIAGRAM

Limiter-Amplifier

The output of Z241/Z242 is applied to a limiter-amplifier circuit in U241. This circuit amplifies the 450 kHz signal and any noise present; then limits this signal to a specific value. When the 450 kHz signal level is high, noise pulses tend to get clipped off by the limiter; however, when the 450 kHz signal level is low, the noise passes through. C242, C243 decouple the 450 kHz signal.

Quadrature Detector

From the limiter stage the signal is fed to the quadrature detector. An external phase-shift network connected to pin 8 shifts the phase of one of the detector inputs 90° at 450 kHz (all other inputs are unshifted in phase). When modulation occurs, the frequency of the IF signal changes at an audio rate as does the phase of the shifted input. The detector, which has no output with a 90° phase shift, converts this phase shift into an audio signal. L242 is tuned to provide maximum undistorted output from the detector. R242 is used to lower the Q of L242. From the detector the audio and data signal is fed out on pin 9.

Audio/Data Amplifier

The audio/data output of U241 on pin 9 is fed to the audio amplifier U261. U261 amplifies the detected audio/data signal and shifts the DC bias level to 2.5V. The gain is set at approximately 1.5 by R261/R262. R263 and R264 provide a 1.9V DC reference bias voltage. The audio output of U261 is applied to J201, pin 13.

Receive Signal Strength Indicator (RSSI)

U241, pin 13 is an output for the RSSI circuit which provides a current proportional to the strength of the 450 kHz IF signal. The voltage developed across R241 is applied to J201, pin 12.

4.4 TRANSMITTER CIRCUIT DESCRIPTION

4.4.1 BUFFER (Q851)

The output signal is applied to a 50-ohm pad formed by R851, R852, and R853. This pad provides attenuation and isolation. Q851 provides amplifica-

tion and also additional isolation between the VCO and transmitter. Biasing for this stage is provided by R854, and decoupling of RF signals is provided by C852. Impedance matching with the transmitter is provided by L501 and C502, and impedance matching with the receiver is provided by L301, C302.

4.4.2 PRE-DRIVER (Q501), DRIVER (Q521)

Pre-driver Q501 is biased class A by R501 and R502 and R506. L501 and C502 match Q501 to Q851. C520 and C508 bypass RF from the DC line, and R503 provides supply voltage isolation. R507 ties the +7.5V supply to the circuit for high power applications and R508 ties the circuit to +5V for low power applications. Impedance matching between Q501 and Q521 is provided by L502, L503 and C511. R504 and C504 provide negative feedback to prevent oscillation.

Driver Q521 is biased nearly Class C by R521 and R522. Impedance matching with Q541 is provided by L521, C525, C527, L522 and C526.

4.4.3 -5V POWER CONTROL SUPPLY

The 17.5 MHz from the TCXO is coupled through C902 to Q901. Bias for Q901 is provided by R903, R904, R901, R902 and R905. C901 and C903 provide RF decoupling. The amplified signal rectified by CR901/CR902 to produce a -5V DC source. C909 stabilizes the voltage level and C910 and C911 provide RF decoupling. This -5V source is used in the transmit power control circuit U542.

4.4.4 FINAL (Q541), POWER CONTROL (U542)

Q541 is biased for Class C operation. The output is matched to the low-pass filter by L541, C552, and several capacitors. The supply voltage is isolated from RF by ferrite bead EP541.

Power control is provided by U542. The 5.5V transmit supply is passed by U542 to power adjust R542. The other end of R542 is the rectified -5V from Q901. This negative voltage is required when low power is used to pinch off Q541 to the required output.

The -2V applied to the VCO is derived from the TCXO frequency that is amplified by Q833, rectified by CR831 and filtered by C844, C845, C846 and C847 on the RF board.

The VCO frequency is modulated using a similar method. The transmit audio/data signal is applied across varactor diode CR852 which varies the VCO frequency at an audio rate. Series capacitors C856/C870 set the amount of deviation produced along with CR853 and C858. R854 provides a DC ground on the anodes of CR852/CR853, and isolation is provided by R852 and C855.

The DC voltage across CR853 provides compensation to keep modulation relatively flat over the entire bandwidth of the VCO. This compensation is required because modulation tends to increase as the VCO frequency gets higher (capacitance of CR854/CR855/CR856/CR851 gets lower). CR853 also balances the modulation signals applied to the VCO and TCXO. An external voltage from J201, pin 14 can also adjust the modulation.

The DC voltage applied across CR853 comes from the modulation adjust control R810. R811 applies a DC biasing voltage to CR852; C814 provides DC blocking; and C818 attenuates AC signals applied through R811. RF isolation is provided by C858, R853, C817 and R812.

4.2.3 VCO AND REFERENCE OSCILLATOR MODULATION

Both the VCO and reference oscillator (TCXO) are modulated in order to achieve the required frequency response. If only the VCO was modulated, the phase detector in U801 would sense the frequency change and increase or decrease the VCO control voltage to counteract the change (especially at the lower audio frequencies). If only the reference oscillator frequency is modulated, the VCO frequency would not change fast enough (especially at the higher audio frequencies). Modulating both VCO and reference oscillators produces a flat audio response. Potentiometer R810 sets the VCO modulation sensitivity so that it is equal to the reference oscillator modulation sensitivity.

4.2.4 CASCODE AMPLIFIERS (Q851/Q852)

The output signal on the collector of Q850 is coupled by L861/C864 to buffer amplifier Q851/Q852. This is a shared-bias amplifier which provides amplification and also isolation between the VCO and the stages which follow. The signal is direct coupled from the collector of Q852 to the emitter of Q851. The resistors in this circuit provide biasing and stabilization, and C865 and C866 are bypass capacitors.

4.2.5 AMPLIFIER (Q853)

Amplifier Q853 provides amplification and isolation between the VCO and receiver and transmitter. C868 provides matching between the amplifiers. Bias for Q853 is provided by R871, R872 and R874. Inductor L856 and capacitor C873 provide impedance matching on the output.

4.2.6 VOLTAGE FILTER (Q832)

Q832 is a capacitance multiplier to provide filtering of the 4.6V supply to the VCO. R836 provides transistor bias and C834 provides the capacitance that is multiplied. If a noise pulse or other voltage change appears on the collector, the base voltage does not change significantly because of C834. Therefore, base current does not change and transistor current remains constant. CR832 decreases the charge time of C834 when power is turned on. This shortens the startup time of the VCO. C841, C840 and C855 are RF decoupling capacitors.

4.2.7 VCO FREQUENCY SHIFT (Q831)

The VCO must be capable of producing frequencies from approximately 403-564.95 MHz to produce the required receive injection and transmit frequencies. If this large of a shift was achieved by varying the VCO control voltage, the VCO gain would be undesirably high. Therefore, capacitance is switched in and out of the tank circuit to provide a coarse shift in frequency.

This switching is controlled by the T/R pin shift on J201, pin 4, Q831/Q834 and pin diode CR850. When a pin diode is forward biased, it presents a vary

SECTION 5 SERVICING

5.1 GENERAL

5.1.1 PERIODIC CHECKS

This transceiver should be put on a regular maintenance schedule and an accurate performance record maintained. Important checks are receiver sensitivity and transmitter frequency, modulation, and power output. A procedure for these and other tests is located in Section 6. It is recommended that transceiver performance be checked annually even though periodic checks are not required by the FCC. During the first year, make an additional check or two to ensure no TCXO frequency drifting has occurred.

5.1.2 SURFACE-MOUNTED COMPONENTS

A large number of the components used on the transceiver board are the surface-mounted type. Since these components are relatively small in size and are soldered directly to the PC board, care must be used when they are replaced to prevent damage to the component or PC board. Surface-mounted components should not be reused because they may be damaged by the unsoldering process.

5.1.3 SCHEMATIC DIAGRAMS AND COMPONENT LAYOUTS

Schematic diagrams and component layouts of the PC boards used in this transceiver are located in Section 8. A component locator guide is also provided to aid in component location.

5.1.4 REPLACEMENT PARTS LIST

A replacement parts list with all the parts used in this transceiver is located in Section 7. Parts are listed alphanumerically according to designator. For information on ordering parts, refer to Section 1.8.

5.1.5 TCXO MODULE NOT SERVICEABLE

The ± 1.5 PPM TCXO module is not field serviceable. Part changes require a factory recalibration to ensure that the oscillator stays within its ± 1.5 PPM tolerance.

5.2 SYNTHESIZER SERVICING

5.2.1 INTRODUCTION

When there is a synthesizer malfunction, the VCO is not locked on frequency. When an unlocked VCO is detected by the lock detector circuit, U801, pin 18 goes low (0V).

NOTE: The user-supplied circuitry must disable the transmitter and receiver when an out-of-lock condition is indicated.

When the VCO is unlocked, the fr and fv inputs to the phase detector are usually not in phase (see Section 4.1.2). The phase detector in U801 then causes the VCO control voltage to go to the high or low end of its operating range. This in turn causes the VCO to oscillate at the high or low end of its frequency range.

As shown in Figure 4-1, a loop is formed by VCO Q850, amplifier Q851/Q852, and the RF IN of U801. Therefore, if any of these components begin to malfunction, improper signals appear throughout the loop. However, correct operation of the counters can still be verified by measuring the input and output frequencies to check the divide number.

Proceed as follows to check the synthesizer I/O signals to determine if it is operating properly.

5.2.2 REFERENCE OSCILLATOR

Check the signal at U801, pin 8. It should be 17.5 MHz at a level of approximately 1.5V P-P. If the TCXO module is defective, it is not serviceable and must be replaced with a new module as described in Section 5.1.5.

5.2.3 VCO

Output Level

The output level of Q853 can be measured with an RF voltmeter or some other type of high impedance meter. The minimum level after a power splitter at R851 should be -10 dBm.

4.3.2 MIXER (U221), FIRST LO AMPLIFIER (Q301)

First mixer U221 mixes the receive frequency with the first injection frequency to produce the 52.95 MHz first IF. Since high-side injection is used, the injection frequency is 52.95 MHz above the receive frequency. The RF signal is coupled to the mixer through C211.

The first injection frequency from the VCO is coupled to the first local oscillator amplifier Q301 through C301. L301 and C302 match Q301 to the VCO. Bias for Q301 is provided by R301, R302 and R303, and C303 decouples RF signals. Impedance matching to the mixer is provided by L302, R304 and C304.

4.3.3 AMPLIFIER (Q222), CRYSTAL FILTER (Z221/Z222), IF AMP (Q221)

The output of U221 is coupled to buffer Q222. C222, R229 and Q222 match the 50 ohm output of U221. Bias for Q222 is provided by R228 and R229. The output of Q222 is matched to crystal filter Z221 via L222, C223 and R230. This filter presents a low impedance to 52.95 MHz and attenuates the receive, injection, and other frequencies outside the 52.95 MHz passband.

Z221 and Z222 form a 2-section, 4-pole crystal filter with a center frequency of 52.95 MHz and a -3 dB passband of 8 kHz (12.5 kHz BW) or 15 kHz (20/25 kHz BW). This filter establishes the receiver selectivity by attenuating the adjacent channel and other signals close to the receive frequency. C232, C224, and L223 adjust the coupling of the filter. L224, C225 and C227 provide impedance matching between the filter and Q221.

IF amplifier Q221 amplifies the 52.95 MHz IF signal to recover filter losses and improves receiver sensitivity. Biasing for Q221 is provided by R222, R223, R225 and R226 and C228, C229 decouple RF signals. The output of Q221 is coupled to the detector by C230.

4.3.4 SECOND LO AMP/TRIPLER (Q401), SECOND IF FILTER (Q901)

The input frequency to Q401 is 17.5 MHz from TCXO Y801 coupled through C402. Bias for Q401 is provided by R401, R402, R403 and R404. C403, C404 decouple RF from the amplifier. L401, L402, C405, C406 and C407 pass the third harmonic of the input (52.5 MHz) to U241, pin 1. The output of the amplifier is coupled to U241, pin 1 by C241, and C410 and L404 provided low frequency decoupling.

4.3.5 SECOND MIXER/DETECTOR (U241)

Oscillator and Mixer

As shown in Figure 4-3, U241 contains the second oscillator, second mixer, limiter, detector, and squelch circuitry. The 52.95 MHz IF signal is mixed with a 52.5 MHz signal produced by second LO amplifier Q401 from TCXO Y801.

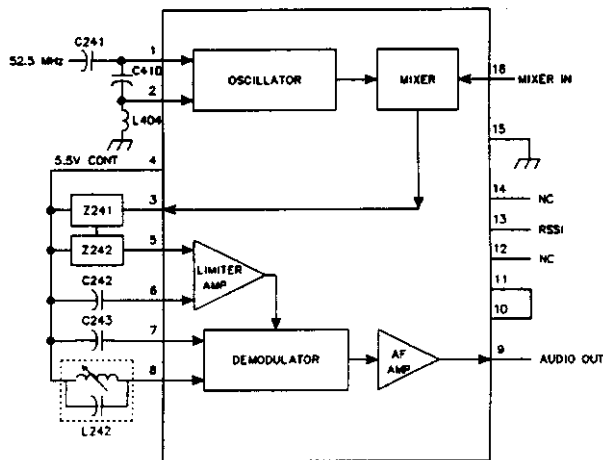

Figure 4-3 U241 BLOCK DIAGRAM

Second IF Filter

The output of the internal double-balanced mixer is the difference between 52.95 MHz and 52.5 MHz which is 450 kHz. This 450 kHz signal is fed out on pin 3 and applied to second IF filters Z241 and Z242. These filters have passbands of 9 kHz (12.5 kHz BW), 15 kHz (20 kHz BW) or 20 kHz (25 kHz BW) at the -6 dB points and are used to attenuate wideband noise.

5.3.3 RF AMPLIFIER (Q201) AND FIRST MIXER (Q221)

Refer to the schematic diagram for signal levels and test points for measuring levels.

5.3.4 RF AND IF AMPLIFIERS, FIRST MIXER

Check the DC voltages shown on the schematic diagram. If they are normal, inject a signal at the input and output of each stage using a .01 μ F coupling capacitor. If the stage is producing gain, the injection level on the input of a stage should be less than that required on the output to produce the same SINAD at the receive output.

5.4 TRANSMITTER SERVICING

5.4.1 SUPPLY VOLTAGES AND CURRENT

Measure the supply voltages on the following pins of interface connector J201:

- Pin 2 - 7.5V DC
- Pin 3 - 7.5V DC
- Pin 4 - 0.0V DC (while transmitting)
- Pin 5 - 5.0V DC
- Pin 6 - 2.5V DC Transmit In/1.5V P-P max

Place a DC ammeter in the supply line to the transceiver and the following maximum currents should be measured:

- Pin 2 - 650 mA
- Pin 3 - 250 mA
- Pin 5 - 12 mA

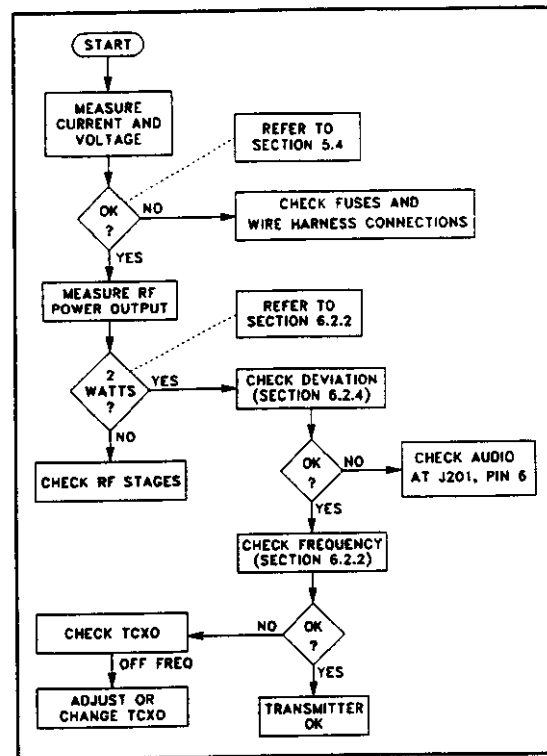

Figure 5-2 TRANSMITTER SERVICING FLOWCHART

CIRCUIT DESCRIPTION

The low-pass filter consists of L561, C561, L562, C562, L563, C563 and L564. The filter attenuates spurious frequencies occurring above the transmit frequency band. The transmit signal is then fed through the antenna switch to antenna jack J501.

4.4.5 ANTENNA SWITCH (CR561, CR562)

The antenna switching circuit switches the antenna to the receiver in the receive mode and the transmitter in the transmit mode. In the transmit mode, +7.5V is applied to L565 and current flows through diode CR561, L566, diode CR562, and R562/R563. When a diode is forward biased, it presents a low impedance to the RF signal; conversely, when it is reverse biased (or not conducting), it presents a high impedance (small capacitance). Therefore, when

CR561 is forward biased, the transmit signal has a low-impedance path to the antenna through coupling capacitor C568.

C567, L566, and C570 form a discrete quarter-wave line. When CR561 is forward biased, this quarter-wave line is effectively AC grounded on one end by C570. When a quarter-wave line is grounded on one end, the other end presents a high impedance to the quarter-wave frequency. This blocks the transmit signal from the receiver. C569 matches the antenna to 50 ohms in transmit and receive.

In the receive mode, no power is applied to L565, so all the diodes are "off". The receive signal then has a high-impedance path into the transmitter and a low-impedance path into the receiver because the quarter-wave line is not grounded.

SECTION 6 ALIGNMENT PROCEDURE AND PERFORMANCE TESTS

6.1 GENERAL

Receiver or transmitter alignment may be necessary if repairs are made that could affect tuning. Alignment points diagrams are located in Figure 6-3 or component layouts are located in Section 8.

Fabricate test cables by referring to Figure 2-1. This cable should include power and ground, a transmit keying switch that shorts the keying line to ground, data input and data output. The test setup must apply the various supply voltages and load the synthesizer with channel information.

6.2 DL3474 TRANSCEIVER ONLY

6.2.1 FREQUENCY AND CONTROL LINE VOLTAGE CHECK

1. Connect the test setup shown in Figure 6-1. Set the power supply for +7.5V DC. See Figure 2-1 for interface cable.
2. Load the synthesizer with the channel frequency (see Section 3.2).
3. Connect a DC voltmeter at the junction of R808/C815 to measure the VCO control line voltage for a meter reading of $\geq 0.50 - \leq 4.90$ V DC (see Figure 6-3).
4. Key the transmitter.
5. Measure the VCO control line voltage for a meter reading of $\geq 0.75 - \leq 5.00$ V DC
6. Unkey the transmitter.

6.2.2 2W TRANSMITTER POWER ALIGNMENT

1. Connect the test setup shown in Figure 6-1. A DC ammeter capable of measuring up to 1.5A should be installed in the supply line.
2. Load the synthesizer with the center channel frequency.

3. Key the transmitter and make sure that the supply voltage at the RF board is 7.5V.
(Do not transmit for extended periods.)
4. Adjust C553 counterclockwise for minimum current.
5. Connect a voltmeter to the junction of R542/R543.
6. Adjust R542 clockwise for 2.30V DC (+0/-0.1V DC).
7. Readjust C553 counterclockwise for minimum current.
8. Tune C527 clockwise for maximum power.
9. Tune C553 clockwise for 2.0W (± 0.1 W). Current should be less than 900 mA. (Power output should be 1.6-2.4W and current less than 900 mA from 403-512 MHz.)
10. Monitor the frequency with a frequency counter and adjust TCXO (Y801) for the channel frequency ± 100 Hz.

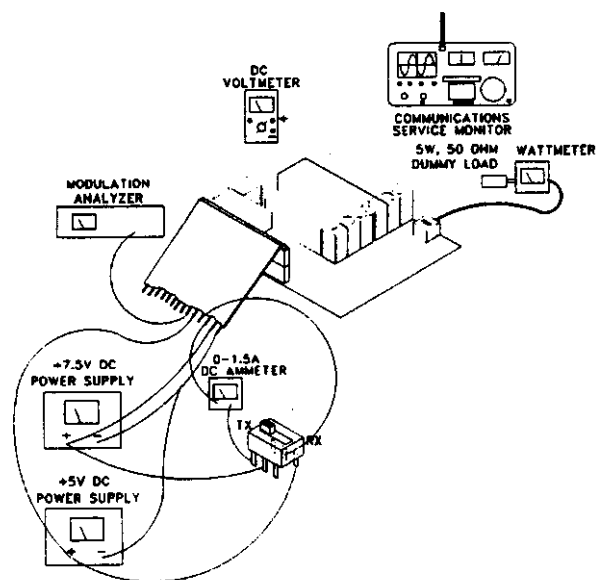

Figure 6-1 TRANSMITTER TEST SETUP

Control Voltage

Check the DC voltage at C815 with a channel near the center of the band. If the VCO is locked on frequency, this should be a steady DC voltage near 3V. If it is not locked on frequency, it should be near the lower or upper end of its range (0V or 5.5V).

Output Frequency

Check the VCO frequency at R851. If the VCO is locked on frequency, it should be stable on the transmit channel frequency. If the VCO is not locked on frequency, the VCO control voltage is probably near 0V or 5.5V.

5.2.4 SYNTHESIZER (U801)

Lock Detector

When the VCO is locked on frequency, the lock detect output on J201, pin 7 should be high.

5.3.2 MIXER/DETECTOR (U201)

Data Output

Using a .01 μ F coupling capacitor, inject at U241, pin 16, a 52.95 MHz, 1 mV signal, modulated with 1 kHz at ± 3 kHz deviation. The audio output level at U241, pin 9 should be approximately 400 mV RMS.

The data output on J201, pin 13 should be 600 mV to 1.2V P-P or 212 mV to 424 mV RMS with the preceding injection signal.

RSSI Output

The RSSI output on J201, pin 12 should be greater than 100 mV at 12 dB SINAD and less than 2.5V with 1 mV input. If either of the preceding measurements is not correct, there may be a problem with U241.

5.3 RECEIVER SERVICING

To isolate a receiver problem to a specific section, refer to the troubleshooting flowchart in Figure 5-1. Tests referenced in the flowchart are described in the following information.

NOTE: Supply voltages are provided by the user.

5.3.1 SUPPLY VOLTAGES AND CURRENT

Measure the supply voltages on the following pins at interface connector J201:

- Pin 4 - 5.0V DC Receive
- Pin 5 - 5.0V DC

Place a DC ammeter in the supply line to the transceiver and the following maximum currents should be measured:

- Pin 4 - 10 mA
- Pin 5 - 50 mA

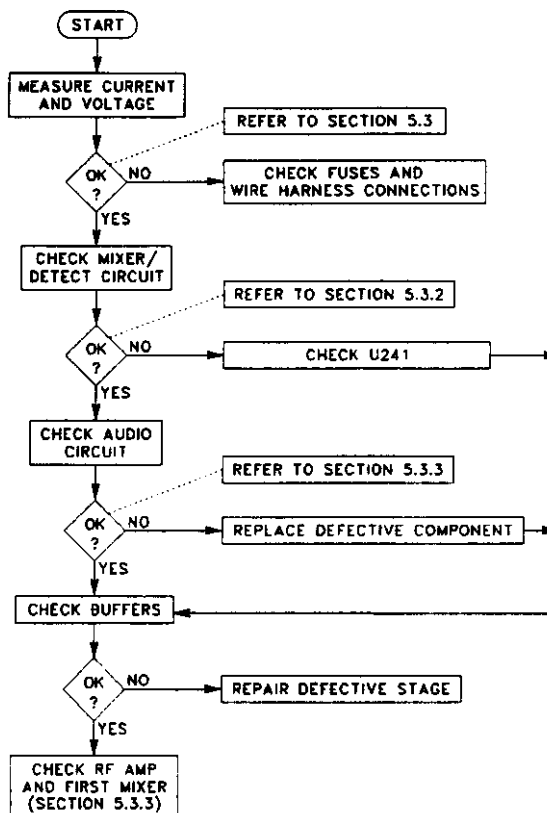

Figure 5-1 RECEIVER SERVICING FLOW-CHART

2. Measure the receive current drain. (Typically current should be <80 mA.)
3. Preset tuning slugs of L222/L224 to the full clockwise position (slug in all the way).
4. Preset C232 to center position (slot in-line with axis of part).
5. Readjust L224 counterclockwise 2 turns.

6.2.6 IF AND AUDIO ADJUSTMENTS

1. Load the synthesizer with the channel frequency.
2. Set the RF signal generator for this frequency with a 1 kHz tone (modulated output shown below) at a level of -47 dBm (1000 μ V) and inject into J501.
 - 1.5 kHz deviation (-X10 12.5 kHz BW Radio)
 - 2.4 kHz deviation (-X20 20.0 kHz BW Radio)
 - 3.0 kHz deviation (-X30 25.0 kHz BW Radio)

NOTE: Maintain these deviation levels throughout the test when measuring AC levels, SINAD and % distortion.

3. Adjust L242 for 2.5V DC (± 0.05 V DC) at the receive audio output.
4. Set the RF signal generator level to -105 dBm, "unmodulated".
5. Set the generator frequency 3 kHz below channel center (-X10) or 5 kHz below channel center (-X20/-X30).

6. Adjust C232, then L222 for peak RSSI voltage.

NOTE: Use 2V scale on DVM.

7. Set the RF signal generator frequency back to channel center at -47 dBm with standard deviation level.
8. Adjust L224 for minimum distortion.
9. Set the RF signal generator to -105 dBm, "unmodulated".
10. Adjust L222 for peak RSSI voltage.

NOTE: Use 2V scale on DVM.

11. Adjust deviation to the level in Step 2. Record the RMS voltage level _____ RMS. (Typically 300 mV \pm 50 mV.)
12. Record the percent distortion _____. (Typically <3%.)
13. Adjust the RF input level until 12 dB SINAD is measured. (Typically <0.45 μ V).
14. Adjust the generator RF level to -120 dBm and measure DC (RSSI) voltage on J201, pin 12. (Typically \leq 0.90V DC.)
15. Adjust the generator RF level to -60 dBm and measure DC (RSSI) voltage on J201, pin 12. (Typically \geq 2.40V DC.)

This page intentionally left blank.

SECTION 7 PARTS LIST

SYMBOL NUMBER	DESCRIPTION	PART NUMBER	SYMBOL NUMBER	DESCRIPTION	PART NUMBER
HIGH-SPEC DATA TRANSCEIVER					
PART NO. 242-3474-XX0					
A 801	VCO 403-419 MHz	023-3474-240	C 206	68 pF ±5% NPO 0603	510-3674-680
A 801	VCO 419-435 MHz	023-3474-340	C 207	68 pF ±5% NPO 0603	510-3674-680
A 801	VCO 435-451 MHz	023-3474-440	C 208	68 pF ±5% NPO 0603	510-3674-680
A 801	VCO 450-466 MHz	023-3474-540	C 209	220 pF ±5% NPO 0603	510-3674-221
A 801	VCO 464-480 MHz	023-3474-640	C 210	4.7 pF ±0.1% NPO 0603 (403-435 MHz)	510-3673-479
A 801	VCO 480-496 MHz	023-3474-740		3.6 pF ±0.1% NPO 0603	510-3673-369
A 801	VCO 496-512 MHz	023-3474-840		(435-480 MHz)	
				3 pF ±0.1% NPO 0603	510-3673-300
				(480-512 MHz)	
C 101	68 pF ±5% NPO 0603	510-3674-680	C 222	.01 μF ±5% X7R 0603 chip	510-3675-103
C 102	68 pF ±5% NPO 0603	510-3674-680	C 223	3.9 pF ±0.1% NPO 0603	510-3673-399
C 103	68 pF ±5% NPO 0603	510-3674-680	C 224	4.7 pF ±0.1% NPO 0603	510-3673-479
C 104	68 pF ±5% NPO 0603	510-3674-680	C 225	.01 μF ±10% X7R 0603 (12.5 kHz BW)	510-3675-103
C 105	68 pF ±5% NPO 0603	510-3674-680		39 pF ±5% NPO 0603	510-3674-390
C 106	68 pF ±5% NPO 0603	510-3674-680		(20-25 kHz BW)	
C 107	68 pF ±5% NPO 0603	510-3674-680	C 226	.01 μF ±10% X7R 0603	510-3675-103
C 108	68 pF ±5% NPO 0603	510-3674-680		8.2 pF ±0.1% NPO 0603	510-3673-829
C 109	68 pF ±5% NPO 0603	510-3674-680		(12.5 kHz BW)	
C 110	68 pF ±5% NPO 0603	510-3674-680	C 227	12 pF ±5% NPO 0603 (20-25 kHz BW)	510-3674-120
C 111	68 pF ±5% NPO 0603	510-3674-680			
C 112	68 pF ±5% NPO 0603	510-3674-680	C 228	.01 μF ±10% X7R 0603	510-3675-103
C 113	68 pF ±5% NPO 0603	510-3674-680	C 229	.01 μF ±10% X7R 0603	510-3675-103
C 114	1 μF 16V SMD tantalum	510-2625-109	C 230	.01 μF ±10% X7R 0603	510-3675-103
C 115	68 pF ±5% NPO 0603	510-3674-680	C 232	1.5-5 pF ceramic SMD	512-1602-001
C 116	.01 μF ±10% X7R 0603	510-3675-103	C 233	.01 μF ±10% X7R 0603	510-3675-103
C 117	1 μF 16V SMD tantalum	510-2625-109	C 234	.01 μF ±10% X7R 0603	510-3675-103
C 118	68 pF ±5% NPO 0603	510-3674-680	C 235	68 pF ±5% NPO 0603	510-3674-680
C 123	68 pF ±5% NPO 0603	510-3674-680	C 241	.01 μF ±10% X7R 0603	510-3675-103
C 124	1 μF 16V SMD tantalum	510-2625-109	C 242	.1 μF ±5% X7R 1206	510-3609-104
C 125	1 μF 16V SMD tantalum	510-2625-109	C 243	.1 μF ±5% X7R 1206	510-3609-104
C 126	.01 μF ±10% X7R 0603	510-3675-103	C 245	.01 μF ±10% X7R 0603	510-3675-103
			C 246	1 μF 16V SMD tantalum	510-2625-109
C 201	68 pF ±5% NPO 0603	510-3674-680	C 247	.01 μF ±10% X7R 0603	510-3675-103
C 202	68 pF ±5% NPO 0603	510-3674-680	C 248	.01 μF ±10% X7R 0603	510-3675-103
C 203	68 pF ±5% NPO 0603	510-3674-680	C 261	27 pF ±5% NPO 0603	510-3674-270
C 204	8.2 pF ±0.1% NPO 0603 (403-419 MHz)	510-3673-829	C 262	68 pF ±5% NPO 0603	510-3674-680
	6.2 pF ±0.1% NPO 0603 (435-480 MHz)	510-3673-629	C 263	.1 μF ±5% X7R 1206	510-3609-104
	5.6 pF ±0.1% NPO 0603 (480-512 MHz)	510-3673-569	C 301	68 pF ±5% NPO 0603	510-3674-680
C 205	20 pF ±5% NPO 0603	510-3674-200	C 302	10 pF ±0.1% NPO 0603 (403-435 MHz)	510-3673-101
				8.2 pF ±0.1% NPO 0603 (435-466 MHz)	510-3673-829

6.2.3 LOW POWER ALIGNMENT

1. Connect the test setup shown in Figure 6-1.
2. Load the synthesizer with the center channel frequency.
3. Connect a voltmeter to the junction of R542/R543.
4. Adjust R542 clockwise for -1.5V DC ($\pm 0.1V$ DC).
5. Tune C527 clockwise for maximum power.
6. Tune C553 clockwise for minimum power.
7. Adjust R542 for the required power level.
8. Tune C527 for power balance at frequencies which are as close as possible to ± 5 MHz from the center of the channel frequency.
9. Re-adjust R542 for the power level required if necessary.
10. Monitor the frequency with a frequency counter and adjust TCXO (Y801) for the channel frequency ± 100 Hz.

6. The transmit deviation should measure between:
 - $\pm 1.2/\pm 1.9$ kHz for 12.5 kHz BW (-X10 Radios)
 - $\pm 1.9/\pm 3.0$ kHz for 20.0 kHz BW (-X20 Radios)
 - $\pm 2.4/\pm 3.8$ kHz for 25.0 kHz BW (-X30 Radios)
7. Set a 0 dB reference on the Audio Analyzer.
8. Input a 100 Hz sine-wave. The level should be within ± 1.5 dB of the 1 kHz reference.
9. Remove transmit modulation and unkey the transmitter.
10. Connect a DC voltmeter at the junction of R807/R855.
11. Adjust R855 to 2.10V DC ($\pm 0.05V$ DC).

6.2.4 MODULATION FLATNESS ALIGNMENT

1. Inject a 220 Hz square-wave tone at approximately 0.35V P-P, biased at 2.5V DC on J201, pin 6.
2. Transmit into the modulation analyzer and observe modulation output on the oscilloscope. Set the modulation analyzer high pass filtering off and no less than a 15 kHz low pass filter.
3. Adjust R810 for a flat square-wave on the oscilloscope.
4. Inject a 1 kHz sine-wave on J201, pin 6, biased at 2.5V DC, at the level below according to the bandwidth:

- 0.200V RMS for 12.5 kHz BW (-X10 Radios)
- 0.330V RMS for 20.0 kHz BW (-X20 Radios)
- 0.400V RMS for 25.0 kHz BW (-X30 Radios)

5. Switch on TX Modulation. Set the modulation analyzer for 3 kHz low pass filtering.

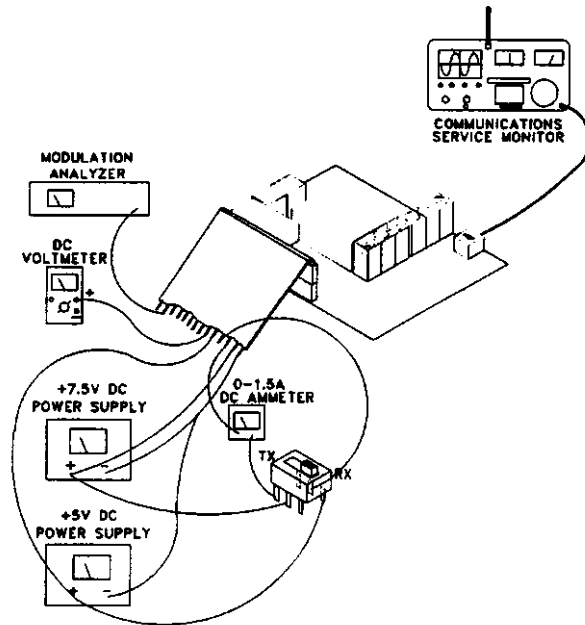

Figure 6-2 RECEIVER TEST SETUP

6.2.5 RECEIVER ALIGNMENT

CAUTION

Do not key the transmitter with the generator connected because severe generator damage may result.

1. Connect the test setup shown in Figure 6-2. Adjust the power supply for +7.5V DC.

SYMBOL NUMBER	DESCRIPTION	PART NUMBER	SYMBOL NUMBER	DESCRIPTION	PART NUMBER
C 552	3.9 pF ±5% NPO 0805	510-3601-399	C 564	.01 μF ±10% X7R 0603	510-3675-103
C 553	2.5-10 pF ceramic SMD	512-1602-002	C 565	68 pF ±5% NPO 0603	510-3674-680
C 554	68 pF ±5% NPO 0603	510-3674-680	C 567	10 pF ±5% NPO 0805 (403-419 MHz)	510-3601-100
C 555	33 pF ±5% NPO 0603 (403-480 MHz)	510-3674-330		7.5 pF ±5% NPO 0805 (419-435 MHz)	510-3601-759
C 555	39 pF ±5% NPO 0603 (480-512 MHz)	510-3674-390	C 567	5.6 pF ±5% NPO 0805 (435-466 MHz)	510-3601-569
C 560	22 pF ±5% NPO 0603	510-3674-220		5.1 pF ±5% NPO 0805 (464-496 MHz)	510-3601-519
C 561	7.5 pF ±5% NPO 0805 (403-419 MHz)	510-3601-759		4.3 pF ±5% NPO 0805 (496-512 MHz)	510-3601-439
	6.2 pF ±5% NPO 0805 (419-435 MHz)	510-3601-629	C 568	47 pF ±5% NPO 0603	510-3674-470
	5.6 pF ±5% NPO 0805 (435-451 MHz)	510-3601-569	C 569	9.1 pF ±5% NPO 0805 (403-419 MHz)	510-3601-919
	5.1 pF ±5% NPO 0805 (450-466 MHz)	510-3601-519		6.8 pF ±5% NPO 0805 (419-435 MHz)	510-3601-689
	4.7 pF ±5% NPO 0805 (464-480 MHz)	510-3601-479		5.6 pF ±5% NPO 0805 (435-451 MHz)	510-3601-569
	4.3 pF ±5% NPO 0805 (480-496 MHz)	510-3601-439		5.1 pF ±5% NPO 0805 (451-466 MHz)	510-3601-569
	3.9 pF ±5% NPO 0805 (496-512 MHz)	510-3601-399		4.7 pF ±5% NPO 0805 (464-512 MHz)	510-3601-479
C 562	8.2 pF ±5% NPO 0805 (403-419 MHz)	510-3601-829	C 570	33 pF ±5% NPO 0603	510-3674-330
	7.5 pF ±5% NPO 0805 (419-435 MHz)	510-3601-759	C 801	.01 μF ±10% X7R 0603	510-3675-103
	6.8 pF ±5% NPO 0805 (435-451 MHz)	510-3601-689	C 802	.01 μF ±10% X7R 0603	510-3675-103
	6.2 pF ±5% NPO 0805 (450-480 MHz)	510-3601-629	C 803	.01 μF ±10% X7R 0603	510-3675-103
	5.6 pF ±5% NPO 0805 (480-496 MHz)	510-3601-569	C 804	3.3 pF ±0.1% NPO 0603	510-3673-339
	5.1 pF ±5% NPO 0805 (496-512 MHz)	510-3601-519	C 805	.01 μF ±10% X7R 0603	510-3675-103
C 563	11 pF ±5% NPO 0805 (403-419 MHz)	510-3601-110	C 806	68 pF ±5% NPO 0603	510-3674-680
	10 pF ±5% NPO 0805 (403-419 MHz)	510-3601-100	C 807	.01 μF ±10% X7R 0603	510-3675-103
	8.2 pF ±5% NPO 0805 (435-451 MHz)	510-3601-829	C 808	68 pF ±5% NPO 0603	510-3674-680
	7.5 pF ±5% NPO 0805 (450-466 MHz)	510-3601-759	C 809	100 pF ±5% NPO 0805	510-3601-101
	6.8 pF ±5% NPO 0805 (464-480 MHz)	510-3601-689	C 810	.1 μF ±5% X7R 1206	510-3609-104
	6.2 pF ±5% NPO 0805 (480-496 MHz)	510-3601-629	C 811	.001 μF ±10% X7R 0603	510-3675-102
	5.6 pF ±5% NPO 0805 (496-512 MHz)	510-3601-569	C 812	.0047 μF ±10% X7R 0805	510-3605-472
			C 813	.001 μF ±10% X7R 0603	510-3675-102
			C 814	1 μF 16V SMD tantalum	510-2625-109
			C 815	.0047 μF ±10% X7R 0805	510-3605-472
			C 817	68 pF ±5% NPO 0603	510-3674-680
			C 818	1 μF 16V SMD tantalum	510-2625-109
			C 819	3.9 pF ±0.1% NPO 0603	510-3673-399
			C 831	.01 μF ±10% X7R 0603	510-3675-103
			C 832	.01 μF ±10% X7R 0603	510-3675-103
			C 833	68 pF ±5% NPO 0603	510-3674-680
			C 834	4.7 μF 10V SMD tantalum	510-2624-479

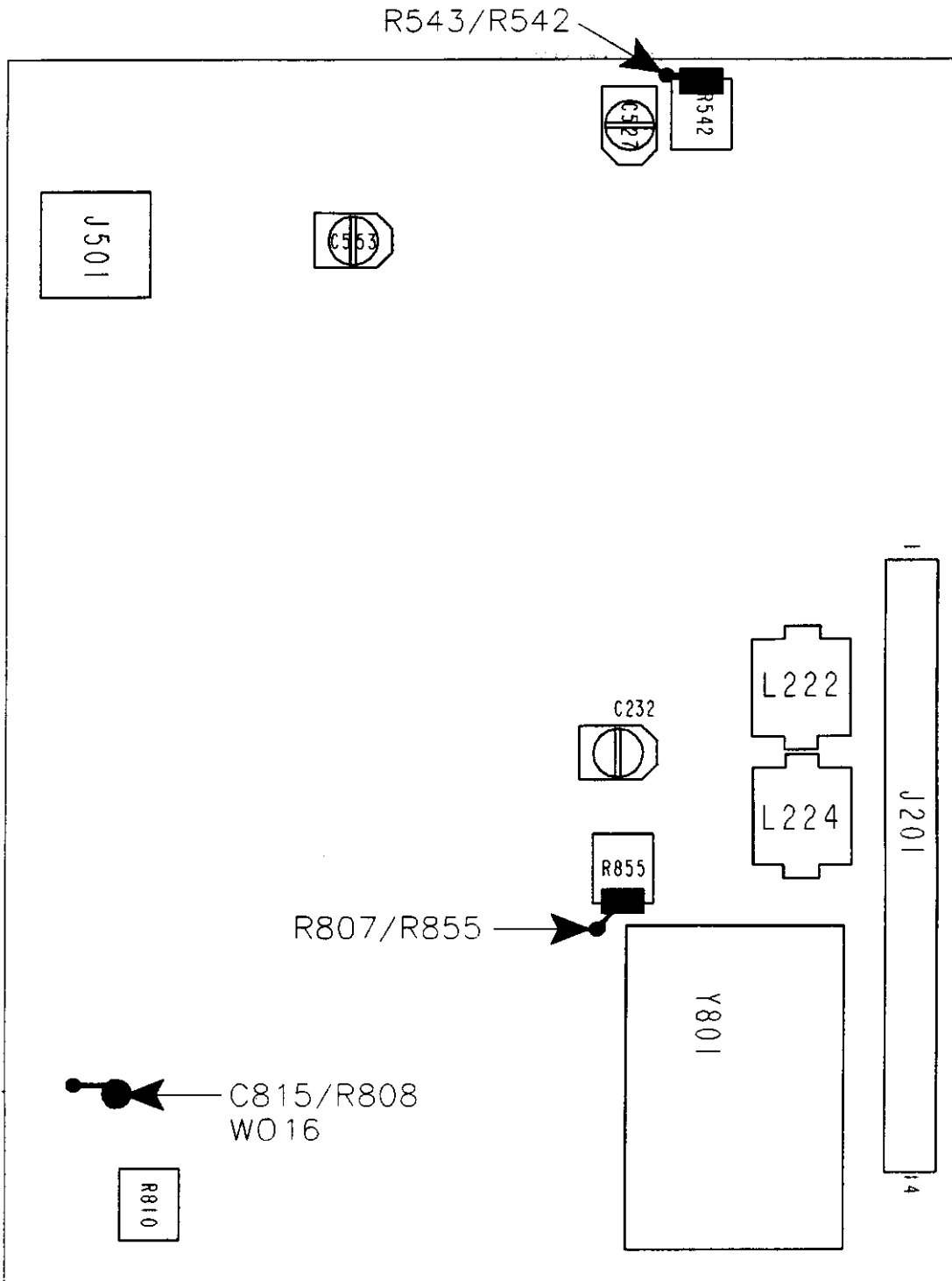

Figure 6-3 ALIGNMENT POINTS DIAGRAM

SYMBOL NUMBER	DESCRIPTION	PART NUMBER	SYMBOL NUMBER	DESCRIPTION	PART NUMBER
L 541	18.5 nH 5-turn SMD air core	542-0030-005	R 120	100k ohm \pm 5% .063W 0603	569-0155-104
L 561	18.5 nH 5-turn SMD air core	542-0030-005	R 121	330k ohm \pm 5% .063W 0603	569-0155-334
L 562	35.5 nH 9-turn SMD air core	542-0030-009			
L 563	35.5 nH 9-turn SMD air core	542-0030-009	R 201	82 ohm \pm 5% .063W 0603	569-0155-820
L 564	18.5 nH 5-turn SMD air core	542-0030-005	R 202	16k ohm \pm 5% .063W 0603	569-0155-163
L 565	1 μ H SMD inductor	542-9001-109	R 203	3.9k ohm \pm 5% .063W 0603	569-0155-392
L 566	12.5 nH SMD air core	542-0030-004	R 204	180 ohm \pm 5% .063W 0603	569-0155-181
			R 222	330 ohm \pm 5% .063W 0603	569-0155-331
L 801	39 μ H \pm 10% SMD NHY0805	542-9003-397	R 223	22k ohm \pm 5% .063W 0603	569-0155-223
L 851	1 μ H SMD inductor	542-9001-109	R 224	1k ohm \pm 5% .063W 0603	569-0155-102
L 901	.68 μ H SMD inductor	542-9001-688	R 225	15k ohm \pm 5% .063W 0603	569-0155-153
MP801	VCO can	017-2225-751	R 226	470 ohm \pm 5% .063W 0603	569-0155-471
MP802	Top shield, transmitter	017-2225-761	R 227	270 ohm \pm 5% .063W 0603	569-0155-271
MP803	Bottom shield, transmitter	017-2225-762	R 228	100 ohm \pm 5% .063W 0603	569-0155-101
MP804	Bottom shield	017-2225-763	R 229	330 ohm \pm 5% .063W 0603	569-0155-331
MP805	Bottom shield	017-2225-764	R 230	2.7k ohm \pm 5% .063W 0603	569-0155-272
MP806	Crystal filter shield	017-2225-699		(12.5 kHz BW)	
				1.8k ohm \pm 5% .063W 0603	569-0155-182
				(20-25 kHz BW)	
PC001	PC board	035-3474-030	R 241	56k ohm \pm 5% .063W 0603	569-0155-563
			R 242	27k ohm \pm 5% .063W 0603	569-0155-273
			R 243	270 ohm \pm 5% .063W 0603	569-0155-271
Q 101	NPN amplifier SOT-23	576-0003-616	R 261	200k ohm \pm 5% .063W 0603	569-0155-204
Q 102	PNP digital w/res SOT-23	576-0003-621		(12.5 kHz BW)	
Q 103	NPN amplifier SOT-23	576-0003-616		120k ohm \pm 5% .063W 0603	569-0155-124
				(20 kHz BW)	
Q 201	NPN low noise SOT-23	576-0003-636		100k ohm \pm 5% .063W 0603	569-0155-104
Q 221	VHF/UHF amp SOT-23	576-0003-634		(25 kHz BW)	
Q 222	Si N-chnl JFET SOT	576-0006-019	R 262	100k ohm \pm 5% .063W 0603	569-0155-104
			R 263	10k ohm \pm 5% .063W 0603	569-0155-103
Q 301	NPN low noise SOT-23	576-0003-636	R 264	18k ohm \pm 5% .063W 0603	569-0155-183
			R 265	10 ohm \pm 5% .063W 0603	569-0155-100
Q 401	VHF/UHF amp SOT-23	576-0003-634			
Q 501	NPN low noise SOT-23	576-0003-636	R 301	3.3k ohm \pm 5% .063W 0603	569-0155-332
Q 521	NPN .2-2 GHz SO-8	576-0003-604	R 302	1.8k ohm \pm 5% .063W 0603	569-0155-182
Q 541	RF FET	576-0006-450	R 303	180 ohm \pm 5% .063W 0603	569-0155-181
			R 304	1k ohm \pm 5% .063W 0603	569-0155-102
Q 831	NPN amplifier SOT-23	576-0003-616			
Q 832	Si NPN gen purp sw/amp	576-0001-300	R 401	10 ohm \pm 5% .063W 0603	569-0155-100
Q 833	VHF/UHF amp SOT-23	576-0003-634	R 402	15k ohm \pm 5% .063W 0603	569-0155-153
Q 834	PNP digital w/res SOT-23	576-0003-621	R 403	2.7k ohm \pm 5% .063W 0603	569-0155-272
Q 851	Bi-polar MMIC SOT-143	576-0003-638	R 404	330 ohm \pm 5% .063W 0603	569-0155-331
Q 901	VHF/UHF amp SOT-23	576-0003-634	R 501	2.2k ohm \pm 5% .063W 0603	569-0155-222
			R 502	2.2k ohm \pm 5% .063W 0603	569-0155-222
			R 503	10 ohm \pm 5% .063W 0603	569-0155-100
			R 504	560 ohm \pm 5% .063W 0603	569-0155-561

PARTS LIST

SYMBOL NUMBER	DESCRIPTION	PART NUMBER	SYMBOL NUMBER	DESCRIPTION	PART NUMBER
	6.8 pF ±0.1% NPO 0603 (464-496 MHz)	510-3673-689		2.2 pF ±0.1% NPO 0603 (480-496 MHz)	510-3673-229
C 302	6.2 pF ±0.1% NPO 0603 (496-512 MHz)	510-3673-689		1 pF ±0.1% NPO 0603 (496-512 MHz)	510-3673-100
C 302	4.7 pF ±0.1% NPO 0603	510-3673-479	C 520	22 pF ±5% NPO 0603	510-3674-220
C 303	68 pF ±5% NPO 0603	510-3674-680	C 521	68 pF ±5% NPO 0603	510-3674-680
C 304	4.7 pF ±0.1% NPO 0603 (403-435 MHz)	510-3673-479	C 522	.01 μF ±10% X7R 0603	510-3675-103
	3.3 pF ±0.1% NPO 0603 (435-496 MHz)	510-3673-339	C 523	68 pF ±5% NPO 0603	510-3674-680
	3.3 pF ±0.1% NPO 0603 (496-512 MHz)	510-3673-339	C 524	470 pF ±5% NPO 0603	510-3674-471
C 305	.01 μF ±10% X7R 0603	510-3675-103	C 525	27 pF ±5% NPO 0603	510-3674-270
C 306	68 pF ±5% NPO 0603	510-3674-680	C 526	22 pF ±5% NPO 0603 (403-419 MHz)	510-3674-220
C 309	1 μF 16V SMD tantalum	510-2625-109		18 pF ±0.1% NPO 0603 (419-435 MHz)	510-3673-180
C 401	.01 μF ±10% X7R 0603	510-3675-103		15 pF ±5% NPO 0603 (435-512 MHz)	510-3674-150
C 402	.01 μF ±10% X7R 0603	510-3675-103	C 527	2.5-10 pF SMD ceramic	512-1602-002
C 403	.01 μF ±10% X7R 0603	510-3675-103	C 541	68 pF ±5% NPO 0603	510-3674-680
C 404	.01 μF ±10% X7R 0603	510-3675-103	C 542	.01 μF ±10% X7R 0603	510-3675-103
C 405	100 pF ±5% NPO 0603	510-3674-101	C 543	68 pF ±5% NPO 0603	510-3674-680
C 406	6.8 pF ±0.1% NPO 0603	510-3673-689	C 544	.01 μF ±10% X7R 0603	510-3675-103
C 407	100 pF ±5% NPO 0603	510-3674-101	C 545	68 pF ±5% NPO 0603	510-3674-680
C 408	.01 μF ±10% X7R 0603	510-3675-103	C 546	68 pF ±5% NPO 0603	510-3674-680
C 410	.1 μF ±5% X7R 1206	510-3609-104	C 547	68 pF ±5% NPO 0603	510-3674-680
			C 548	1 μF 16V SMD tantalum	510-2625-109
C 501	68 pF ±5% NPO 0603	510-3674-680	C 549	.01 μF ±10% X7R 0603	510-3675-103
C 502	7.5 pF ±0.1% NPO 0603 (435-451 MHz)	510-3673-759	C 550	36 pF ±5% NPO 0805 (403-451 MHz)	510-3601-360
	6.8 pF ±0.1% NPO 0603 (450-480 MHz)	510-3673-689		30 pF ±5% NPO 0805 (450-466 MHz)	510-3601-300
C 503	68 pF ±5% NPO 0603	510-3674-680		27 pF ±5% NPO 0805 (464-480 MHz)	510-3601-270
C 504	470 pF ±5% NPO 0603	510-3674-471		20 pF ±5% NPO 0805 (480-496 MHz)	510-3601-200
C 505	.01 μF ±10% X7R 0603	510-3675-103		18 pF ±5% NPO 0805 (496-512 MHz)	510-3601-180
C 506	68 pF ±5% NPO 0603	510-3674-680		33 pF ±5% NPO 0805 (403-419 MHz)	510-3601-330
C 507	68 pF ±5% NPO 0603	510-3674-680	C 551	27 pF ±5% NPO 0805 (419-435 MHz)	510-3601-270
C 508	68 pF ±5% NPO 0603	510-3674-680		24 pF ±5% NPO 0805 (435-451 MHz)	510-3601-240
C 509	68 pF ±5% NPO 0603	510-3674-680		18 pF ±5% NPO 0805 (450-480 MHz)	510-3601-180
C 510	120 pF ±5% NPO 0603	510-3674-121		16 pF ±5% NPO 0805 (480-496 MHz)	510-3601-160
C 511	6.8 pF ±0.1% NPO 0603 (403-419 MHz)	510-3673-689		15 pF ±5% NPO 0805 (496-512 MHz)	510-3601-150
	5.6 pF ±0.1% NPO 0603 (419-435 MHz)	510-3673-569			
	5.1 pF ±0.1% NPO 0603 (435-451 MHz)	510-3673-519			
	3.9 pF ±0.1% NPO 0603 (450-480 MHz)	510-3673-399			

SYMBOL NUMBER	DESCRIPTION	PART NUMBER	SYMBOL NUMBER	DESCRIPTION	PART NUMBER
Z 202	443 MHz helical filter SMD (435-451 MHz)	532-1005-042	C 854	100 pF $\pm 5\%$ NPO 0603	510-3674-101
Z 202	459 MHz helical filter SMD (450-466 MHz)	532-1005-044	C 855	68 pF $\pm 5\%$ NPO 0603	510-3674-680
Z 202	472 MHz helical filter SMD (464-480 MHz)	532-1005-045	C 856	2.7 pF $\pm 0.1\%$ NPO 0603	510-3673-279
Z 221	52.95 MHz 4-pole 8 kHz BW (12.5 kHz bandwidth)	532-0009-011	C 858	68 pF $\pm 5\%$ NPO 0603	510-3674-680
Z 221	52.95 MHz 4-pole 15 kHz BW (20 kHz and 25 kHz bandwidth)	532-0009-009	C 859	8.2 pF $\pm 0.1\%$ NPO 0603 (403-419 MHz)	510-3673-829
Z 222	52.95 MHz 4-pole 8 kHz BW (12.5 kHz bandwidth)	532-0009-011		7.5 pF $\pm 0.1\%$ NPO 0603 (419-466 MHz)	510-3673-759
Z 222	52.95 MHz 4-pole 15 kHz BW (20 kHz and 25 kHz bandwidth)	532-0009-009	C 859	6.8 pF $\pm 0.1\%$ NPO 0603 (464-480 MHz)	510-3673-689
Z 241	450 kHz, 9 kHz BW (12.5 kHz bandwidth)	532-2004-015	C 859	8.2 pF $\pm 0.1\%$ NPO 0603 (480-496 MHz)	510-3673-829
Z 241	Ceramic data filter (20 kHz bandwidth)	532-2004-016	C 860	1 pF $\pm 0.1\%$ NPO 0603 (403-419/435-451 MHz Only)	510-3673-109
Z 241	450 kHz, 20 kHz BW (25 kHz bandwidth)	532-2004-013	C 861	8.2 pF $\pm 0.1\%$ NPO 0603 (403-435 MHz)	510-3673-829
Z 242	450 kHz, 9 kHz BW (12.5 kHz bandwidth)	532-2004-015		6.8 pF $\pm 0.1\%$ NPO 0603 (435-451 MHz)	510-3673-689
Z 242	Ceramic data filter (20 kHz bandwidth)	532-2004-016		8.2 pF $\pm 0.1\%$ NPO 0603 (450-461 MHz)	510-3673-829
Z 242	450 kHz, 20 kHz BW (25 kHz bandwidth)	532-2004-013		5.6 pF $\pm 0.1\%$ NPO 0603 (464-480 MHz)	510-3673-569
				6.8 pF $\pm 0.1\%$ NPO 0603 (480-496 MHz)	510-3673-689
			C 862	6.8 pF $\pm 0.1\%$ NPO 0603	510-3673-689
			C 863	100 pF $\pm 0.1\%$ NPO 0603 (403-419 MHz)	510-3673-101
				68 pF $\pm 5\%$ NPO 0603 (419-512 MHz)	510-3674-680
			C 864	10 pF $\pm 0.1\%$ NPO 0603	510-3673-100
			C 865	100 pF $\pm 0.1\%$ NPO 0603 (403-419 MHz)	510-3673-101
C 850	68 pF $\pm 5\%$ NPO 0603	510-3674-680		68 pF $\pm 5\%$ NPO 0603 (419-512 MHz)	510-3674-680
C 851	9.1 pF $\pm 0.1\%$ NPO 0603 (403-419 MHz)	510-3673-919		100 pF $\pm 0.1\%$ NPO 0603 (403-419 MHz)	510-3673-101
	8.2 pF $\pm 0.1\%$ NPO 0603 (419-466 MHz)	510-3673-829		68 pF $\pm 5\%$ NPO 0603	510-3674-680
	68 pF $\pm 5\%$ NPO 0603 (466-512 MHz)	510-3674-680		68 pF $\pm 5\%$ NPO 0603 (419-512 MHz)	510-3674-680
C 852	7.5 pF $\pm 0.1\%$ NPO 0603	510-3673-759		100 pF $\pm 0.1\%$ NPO 0603 (403-419 MHz)	510-3673-101
C 853	12 pF $\pm 5\%$ NPO 0603 (403-419 MHz)	510-3674-120	C 867	100 pF $\pm 0.1\%$ NPO 0603 (403-419 MHz)	510-3673-101
	10 pF $\pm 5\%$ NPO 0603 (419-451 MHz)	510-3674-120		68 pF $\pm 5\%$ NPO 0603 (419-512 MHz)	510-3674-680
	9.1 pF $\pm 0.1\%$ NPO 0603 (464-480 MHz)	510-3673-919	C 868	2.4 pF $\pm 0.1\%$ NPO 0603 (403-419 MHz)	510-3673-249
	8.2 pF $\pm 0.1\%$ NPO 0603 (435-451 MHz)	510-3673-829		2.2 pF $\pm 0.1\%$ NPO 0603 (419-435 MHz)	510-3673-229
	8.2 pF $\pm 0.1\%$ NPO 0603 (480-496 MHz)	510-3673-829		1.8 pF $\pm 0.1\%$ NPO 0603 (435-466 MHz)	510-3673-189

VCO

PART NO. 023-3474-X40

SYMBOL NUMBER	DESCRIPTION	PART NUMBER	SYMBOL NUMBER	DESCRIPTION	PART NUMBER
C 835	.01 μ F \pm 10% X7R 0603	510-3675-103	EP541	Ferrite bead SMD	517-2503-001
C 836	.01 μ F \pm 10% X7R 0603	510-3675-103			
C 837	.01 μ F \pm 10% X7R 0603	510-3675-103			
C 838	68 pF \pm 5% NPO 0603	510-3674-680	J 201	14-pin single row receptacle	515-7110-214
C 839	.01 μ F \pm 10% X7R 0603	510-3675-103	J 501	Straight terminal PC bd mt	515-3013-030
C 840	68 pF \pm 5% NPO 0603	510-3674-680			
C 841	.01 μ F \pm 10% X7R 0603	510-3675-103			
C 842	.01 μ F \pm 10% X7R 0603	510-3675-103	L 201	Inductor LL2012 F15N	542-9003-157
C 844	1 μ F 16V SMD tantalum	510-2625-109	L 202	10 nH \pm 10% SMD NHY0805	542-9003-107
C 845	.01 μ F \pm 10% X7R 0603	510-3675-103	L 222	1 μ H \pm 6%5mm variable	542-1012-015
C 846	68 pF \pm 5% NPO 0603	510-3674-680	L 201	15 nH \pm 10% SMD 0805	542-9003-157
C 847	.01 μ F \pm 10% X7R 0603	510-3675-103		(403-466 MHz)	
C 848	68 pF \pm 5% NPO 0603	510-3674-680		12 nH \pm 10% SMD 0805	542-9003-127
C 849	68 pF \pm 5% NPO 0603	510-3674-680		(464-512 MHz)	
C 850	68 pF \pm 5% NPO 0603	510-3674-680	L 202	12 nH \pm 10% SMD 0805	542-9003-127
C 851	68 pF \pm 5% NPO 0603	510-3674-680	L 223	.82 μ H SMD inductor	542-9001-828
C 852	68 pF \pm 5% NPO 0603	510-3674-680	L 224	1 μ H \pm 6%5mm variable	542-1012-015
C 853	1 μ F 16V SMD tantalum	510-2625-109	L 242	680 μ H quad coil	542-5102-001
C 855	68 pF \pm 5% NPO 0603	510-3674-680			
C 901	.01 μ F \pm 10% X7R 0603	510-3675-103	L 301	Inductor LL2012 F12N	542-9003-127
C 902	27 pF \pm 5% NPO 0603	510-3674-270		(403-435 MHz)	
C 903	.01 μ F \pm 10% X7R 0603	510-3675-103	L 301	Inductor LL2012 F10N	542-9003-107
C 904	220 pF \pm 5% NPO 0805	510-3601-221		(435-512 MHz)	
C 905	270 pF \pm 5% NPO 0805	510-3601-271	L 302	Inductor LL2012 F15N	542-9003-157
C 906	.01 μ F \pm 10% X7R 0603	510-3675-103			
C 907	.01 μ F \pm 10% X7R 0603	510-3675-103	L 401	82 nH \pm 10% SMD 0805	542-9003-827
C 908	.01 μ F \pm 10% X7R 0603	510-3675-103	L 402	82 nH \pm 10% SMD 0805	542-9003-827
C 909	1 μ F 16V SMD tantalum	510-2625-109	L 404	1 μ H SMD inductor	542-9001-109
C 910	.01 μ F \pm 10% X7R 0603	510-3675-103			
C 911	68 pF \pm 5% NPO 0603	510-3674-680	L 501	18 nH inductor LL2012 F15N	542-9003-187
				(435-451 MHz)	
				15 nH inductor LL2012 F15N	542-9003-157
				(450-480 MHz)	
CR201	Switching diode SOT-23	523-1504-002	L 502	1 μ H SMD inductor	542-9001-109
CR561	Pin switch diode SOT-23	523-1504-001	L 503	15 nH inductor LL2012 F15N	542-9003-157
CR562	Pin switch diode SOT-23	523-1504-001		(403-496 MHz)	
				12 nH inductor LL2012 F12N	542-9003-127
				(496-512 MHz)	
CR831	Dual switch diode SOT-23	523-1504-023	L 521	43 nH 10-turn SMD air core	542-0030-010
CR901	Dual switch diode SOT-23	523-1504-023	L 522	3.9 nH inductor LL2012 F3N9	542-9003-396
CR902	Dual switch diode SOT-23	523-1504-023		(403-419 MHz)	
				3.3 nH inductor LL2012 F3N3	542-9003-336
				(419-466 MHz)	
				2.7 nH inductor LL2012 F2N7	542-9003-276
EP200	Mini cer crystal pin insulator	010-0345-280		(464-496 MHz)	
				2.2 nH inductor LL2012 F2N2	542-9003-226
EP501	Ferrite bead SMD	517-2503-001		(496-512 MHz)	

SYMBOL NUMBER	DESCRIPTION	PART NUMBER
	Coaxial xmit line 1095 MHz (480-496 MHz Only)	542-9004-007
	Coaxial xmit line 1180 MHz (496-512 MHz Only)	542-9004-008

PARTS LIST

SYMBOL NUMBER	DESCRIPTION	PART NUMBER	SYMBOL NUMBER	DESCRIPTION	PART NUMBER
R 506	100 ohm $\pm 5\%$.063W 0603	569-0155-101	R 852	18 ohm $\pm 5\%$.063W 0603	569-0155-180
R 521	1k ohm $\pm 5\%$.063W 0603	569-0155-102		(403-435 MHz)	
R 522	150 ohm $\pm 5\%$.063W 0603	569-0155-151		39 ohm $\pm 5\%$.063W 0603	569-0155-390
R 524	220 ohm $\pm 5\%$.063W 0603	569-0155-221		(435-480 MHz)	
R 541	220k ohm $\pm 5\%$.063W 0603	569-0155-224		18 ohm $\pm 5\%$.063W 0603	569-0155-180
R 542	1M ohm SMD trimmer	562-0130-105		(480-512 MHz)	
R 543	10k ohm $\pm 5\%$.063W 0603	569-0155-103	R 853	270 ohm $\pm 5\%$.063W 0603	569-0155-271
R 546	47 ohm $\pm 5\%$.063W 0603	569-0155-470		(403-435 MHz)	
R 547	100k ohm $\pm 5\%$.063W 0603	569-0155-104		150 ohm $\pm 5\%$.063W 0603	569-0155-151
R 548	330k ohm $\pm 5\%$.063W 0603	569-0155-334		(435-480 MHz)	
R 549	560k ohm $\pm 5\%$.063W 0603	569-0155-564		270 ohm $\pm 5\%$.063W 0603	569-0155-271
R 562	620 ohm $\pm 5\%$.063W 0603	569-0155-621		(480-512 MHz)	
R 563	620 ohm $\pm 5\%$.063W 0603	569-0155-621	R 854	82 ohm $\pm 5\%$.063W 0603	569-0155-820
R 564	47k ohm $\pm 5\%$.063W 0603	569-0155-473	R 855	100k ohm SMD trimmer	562-0130-104
R 801	10k ohm $\pm 5\%$.063W 0603	569-0155-103	R 856	4.7k ohm $\pm 5\%$.063W 0603	569-0155-472
R 802	10k ohm $\pm 5\%$.063W 0603	569-0155-103	R 857	4.7k ohm $\pm 5\%$.063W 0603	569-0155-472
R 804	10 ohm $\pm 5\%$.063W 0603	569-0155-100	R 858	4.7k ohm $\pm 5\%$.063W 0603	569-0155-472
R 805	27k ohm $\pm 5\%$.063W 0603	569-0155-273	R 860	100 ohm $\pm 5\%$.063W 0603	569-0155-101
R 806	12k ohm $\pm 5\%$.063W 0603	569-0155-123	R 901	22k ohm $\pm 5\%$.063W 0603	569-0155-223
R 807	4.7k ohm $\pm 5\%$.063W 0603	569-0155-472	R 902	15k ohm $\pm 5\%$.063W 0603	569-0155-153
R 808	18k ohm $\pm 5\%$.063W 0603	569-0155-183	R 903	100 ohm $\pm 5\%$.063W 0603	569-0155-101
R 810	220k ohm SMD trimmer	562-0130-224	R 904	330 ohm $\pm 5\%$.063W 0603	569-0155-331
R 811	27k ohm $\pm 5\%$.063W 0603	569-0155-273	R 905	220 ohm $\pm 5\%$.063W 0603	569-0155-221
	(435-451 MHz)		R 906	10 ohm $\pm 5\%$.063W 0603	569-0155-100
	18k ohm $\pm 5\%$.063W 0603	569-0155-183	R 907	2.2k ohm $\pm 5\%$.063W 0603	569-0155-222
	(450-466 MHz)				
	27k ohm $\pm 5\%$.063W 0603	569-0155-273	U 101	5.5V regulator SO-6	544-2603-086
	(435-451 MHz)		U 122	+5V regulator micropower SO	544-2003-067
R 812	10k ohm $\pm 5\%$.063W 0603	569-0155-103			
R 813	100k ohm $\pm 5\%$.063W 0603	569-0155-104	U 221	Double balanced mixer	544-0007-014
R 831	10k ohm $\pm 5\%$.063W 0603	569-0155-103	U 241	FM IF MC3371D SO-16	544-2002-031
R 834	10k ohm $\pm 5\%$.063W 0603	569-0155-103	U 261	Single op amp SOT-23-5	544-2016-001
R 835	1.5k ohm $\pm 5\%$.063W 0603	569-0155-152			
R 836	10k ohm $\pm 5\%$.063W 0603	569-0155-103	U 542	Single op amp SOT23-5	544-2016-001
R 838	100 ohm $\pm 5\%$.063W 0603	569-0155-101			
R 839	680 ohm $\pm 5\%$.063W 0603	569-0155-681	U 801	Fractional-N synthesizer	544-3954-027
R 840	22k ohm $\pm 5\%$.063W 0603	569-0155-223			
R 841	15k ohm $\pm 5\%$.063W 0603	569-0155-153	Y 801	17.5 MHz TCXO ± 1.5 PPM	518-7009-521
R 842	470 ohm $\pm 5\%$.063W 0603	569-0155-471			
R 843	10 ohm $\pm 5\%$.063W 0603	569-0155-100			
R 844	680 ohm $\pm 5\%$.063W 0603	569-0155-681	Z 201	443 MHz helical filter SMD	532-1005-042
R 851	270 ohm $\pm 5\%$.063W 0603	569-0155-271		(435-451 MHz)	
	(403-435 MHz)		Z 201	459 MHz helical filter SMD	532-1005-044
	150 ohm $\pm 5\%$.063W 0603	569-0155-151		(450-466 MHz)	
	(435-480 MHz)		Z 201	472 MHz helical filter SMD	532-1005-045
	270 ohm $\pm 5\%$.063W 0603	569-0155-271		(464-480 MHz)	
	(480-512 MHz)				

This page intentionally left blank.

PARTS LIST

SYMBOL NUMBER	DESCRIPTION	PART NUMBER	SYMBOL NUMBER	DESCRIPTION	PART NUMBER
	1.2 pF $\pm 0.1\%$ NPO 0603 (464-480 MHz)	510-3673-129	L 855	56 nH inductor LL2012 F56N	542-9003-567
	1.8 pF $\pm 0.1\%$ NPO 0603 (480-496 MHz)	510-3673-189	L 856	27 nH $\pm 10\%$ SMD 0805 (403-435 MHz)	542-9003-277
C 870	1 pF $\pm 0.1\%$ NPO 0603	510-3673-109		22 nH $\pm 10\%$ SMD 0805 (435-480 MHz)	542-9003-227
C 871	100 pF $\pm 5\%$ NPO 0603	510-3674-101		18 nH $\pm 10\%$ SMD 0805	542-9003-187
C 873	100 pF $\pm 5\%$ NPO 0603	510-3674-101		(480-512 MHz)	
C 874	3.3 pF $\pm 0.1\%$ NPO 0603 (403-419 MHz)	510-3673-339	L 861	12 nH inductor LL2012 F12N (435-480 MHz)	542-9003-127
C 874	3.3 pF $\pm 0.1\%$ NPO 0603 (419-435 MHz)	510-3673-339		15 nH inductor LL2012 F12N (480-512 MHz)	542-9003-157
	3.3 pF $\pm 0.1\%$ NPO 0603 (435-496 MHz)	510-3673-339	Q 850	NPN transistor NE85619	576-0003-651
C 876	10 pF $\pm 0.1\%$ NPO 0603 (403-419 MHz)	510-3673-100	Q 851	NPN transistor NE85619	576-0003-651
	9.1 pF $\pm 0.1\%$ NPO 0603 (419-435 MHz)	510-3673-919	Q 852	NPN transistor NE85619	576-0003-651
	8.2 pF $\pm 0.1\%$ NPO 0603 (435-496 MHz)	510-3673-829	Q 853	NPN transistor NE85619	576-0003-651
C 877	1.2 pF $\pm 0.1\%$ NPO 0603 (403-435 MHz)	510-3673-129	R 851	10k ohm $\pm 5\%$.063W 0603	569-0155-103
	1 pF $\pm 0.1\%$ NPO 0603 (435-496 MHz)	510-3673-109	R 852	47k ohm $\pm 5\%$.063W 0603	569-0155-473
C 878	10 pF $\pm 0.1\%$ NPO 0603 (403-435 MHz Only)	510-3673-100	R 853	47k ohm $\pm 5\%$.063W 0603	569-0155-473
CR850	Pin switch diode SOT-23	523-1504-001	R 854	10 ohm $\pm 5\%$.063W 0603	569-0155-100
CR851	Varactor SOD-323 BB535	523-5005-022	R 856	10 ohm $\pm 5\%$.063W 0603	569-0155-100
CR852	Varactor diode SOD-123	523-5005-020	R 857	6.8k ohm $\pm 5\%$.063W 0603	569-0155-682
CR853	Varactor diode SOD-123	523-5005-020	R 858	1k ohm $\pm 5\%$.063W 0603	569-0155-102
CR854	Varactor SOD-323 BB535	523-5005-022	R 862	10k ohm $\pm 5\%$.063W 0603	569-0155-103
CR855	Varactor SOD-323 BB535	523-5005-022	R 863	10 ohm $\pm 5\%$.063W 0603	569-0155-100
CR856	Varactor SOD-323 BB535	523-5005-022	R 864	10k ohm $\pm 5\%$.063W 0603	569-0155-103
L 851	82 nH $\pm 10\%$ SMD 0805	542-9003-827	R 865	10k ohm $\pm 5\%$.063W 0603	569-0155-103
L 852	82 nH $\pm 10\%$ SMD 0805 (435-466 MHz)	542-9003-827	R 866	470 ohm $\pm 5\%$.063W 0603	569-0155-471
	150 nH $\pm 10\%$ SMD 0805 (464-480 MHz)	542-9003-158	R 867	12k ohm $\pm 5\%$.063W 0603	569-0155-123
L 853	22 nH $\pm 10\%$ SMD 0805 (403-480 MHz)	542-9003-227	R 868	390 ohm $\pm 5\%$.063W 0603	569-0155-391
	18 nH $\pm 10\%$ SMD 0805 (480-512 MHz)	542-9003-187	R 869	270 ohm $\pm 5\%$.063W 0603	569-0155-271
L 854	82 nH $\pm 10\%$ SMD 0805 (435-466 MHz)	542-9003-827	R 870	18 ohm $\pm 5\%$.063W 0603	569-0155-180
	150 nH $\pm 10\%$ SMD 0805 (464-480 MHz)	542-9003-158	R 871	3.9k ohm $\pm 5\%$.063W 0603	569-0155-392
			R 872	1.8k ohm $\pm 5\%$.063W 0603	569-0155-182
			R 874	680 ohm $\pm 5\%$.063W 0603	569-0155-681
			R 875	270 ohm $\pm 5\%$.063W 0603	569-0155-271
			Z 850	Coaxial xmit line ind 835 MHz (403-419 MHz Only)	542-9004-002
				Coaxial xmit line ind 885 MHz (419-435 MHz Only)	542-9004-003
				Coaxial xmit line ind 935 MHz (435-451 MHz Only)	542-9004-004
				Coaxial xmit line ind 985 MHz (450-466 MHz Only)	542-9004-005
				Coaxial xmit line 1035 MHz (464-480 MHz Only)	542-9004-006