



COMPAL BCL50 Antenna Test Report

Prepared: Allen Lin	Checked:	Approved: Hans JONG	Date: Jan. 28, 2003
DCN: RA-TR000-030003		Version: B	Page: 1 of 6

General

1. Test condition

- (1) Temperature : 15 to 35 ° C
- (2) Humidity : : 25% to 85%
- (3) Atmospheric : 86kPa to 106kPa3. Instrument :
- (1). Network Analyzer : Agilent E8357A

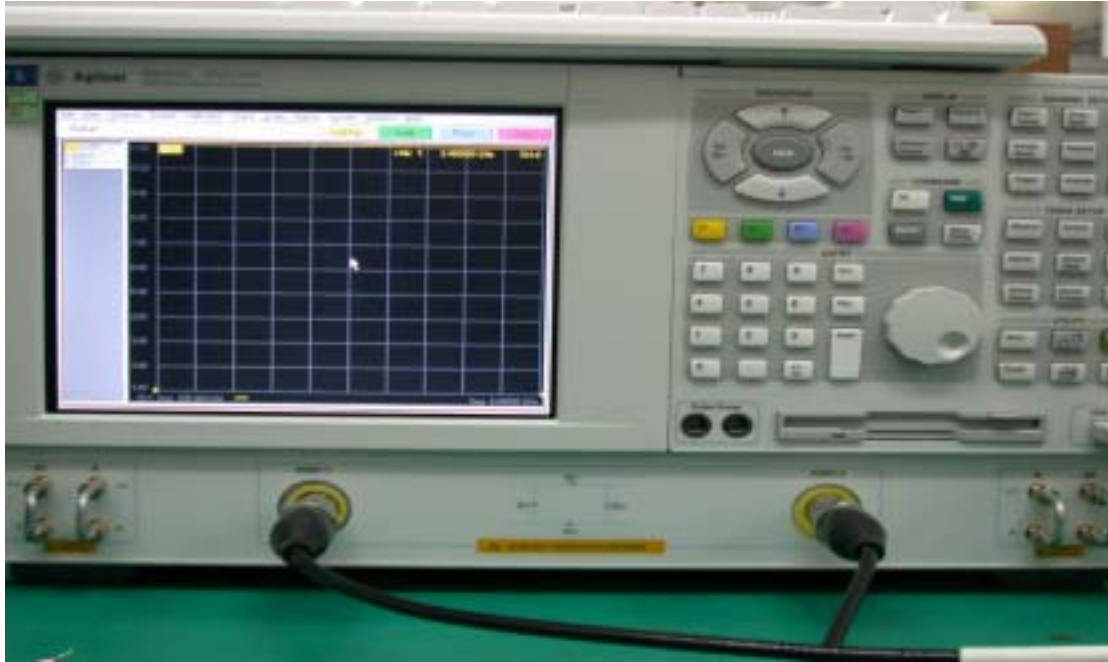

Prepared: Allen Lin	Checked:	Approved: Hans JONG	Date: Jan. 28, 2003
DCN: RA-TR000-030003		Version: B	Page: 2 of 6

CONCLUSION

(a) Electric Specification

	W/L RIGHT ANTENNA	W/L LEFT ANTENNA
PHOTO		
Antenna Type	PIFA	PIFA
Stuff	METAL	PCB
組裝方式	螺絲固定	螺絲固定

V.S.W.R

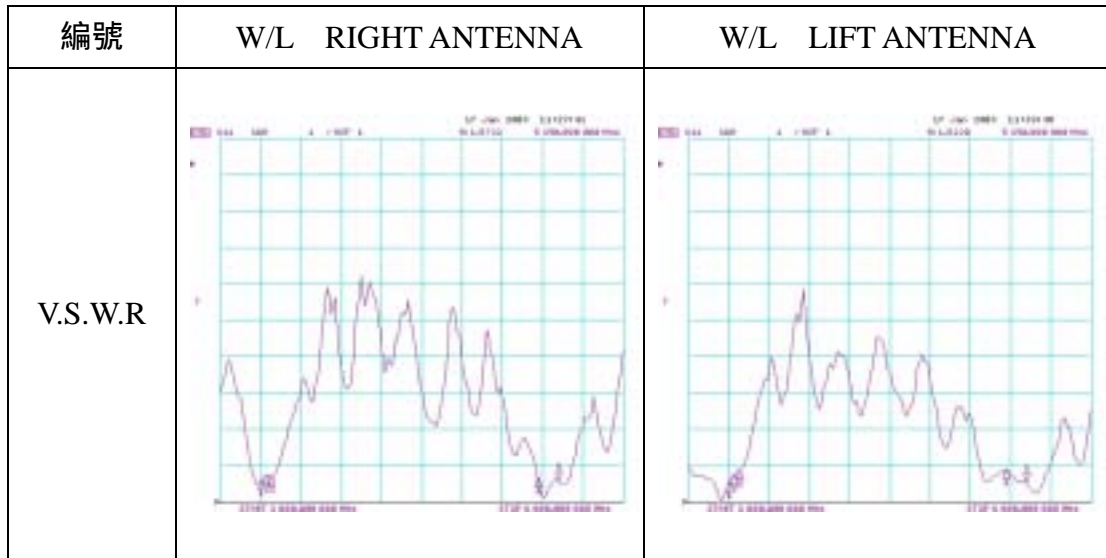

V.S.W.R

	W/L RIGHT ANTENNA	W/L LIFT ANTENNA
2.4GHz	1.60	1.52
2.45GHz	1.72	1.75
2.5GHz	1.60	1.86
5.15GHz	1.65	1.87
5.35GHz	1.57	1.52

(b)Gain & Pattern

— E – Plane - - - - - H-Plane

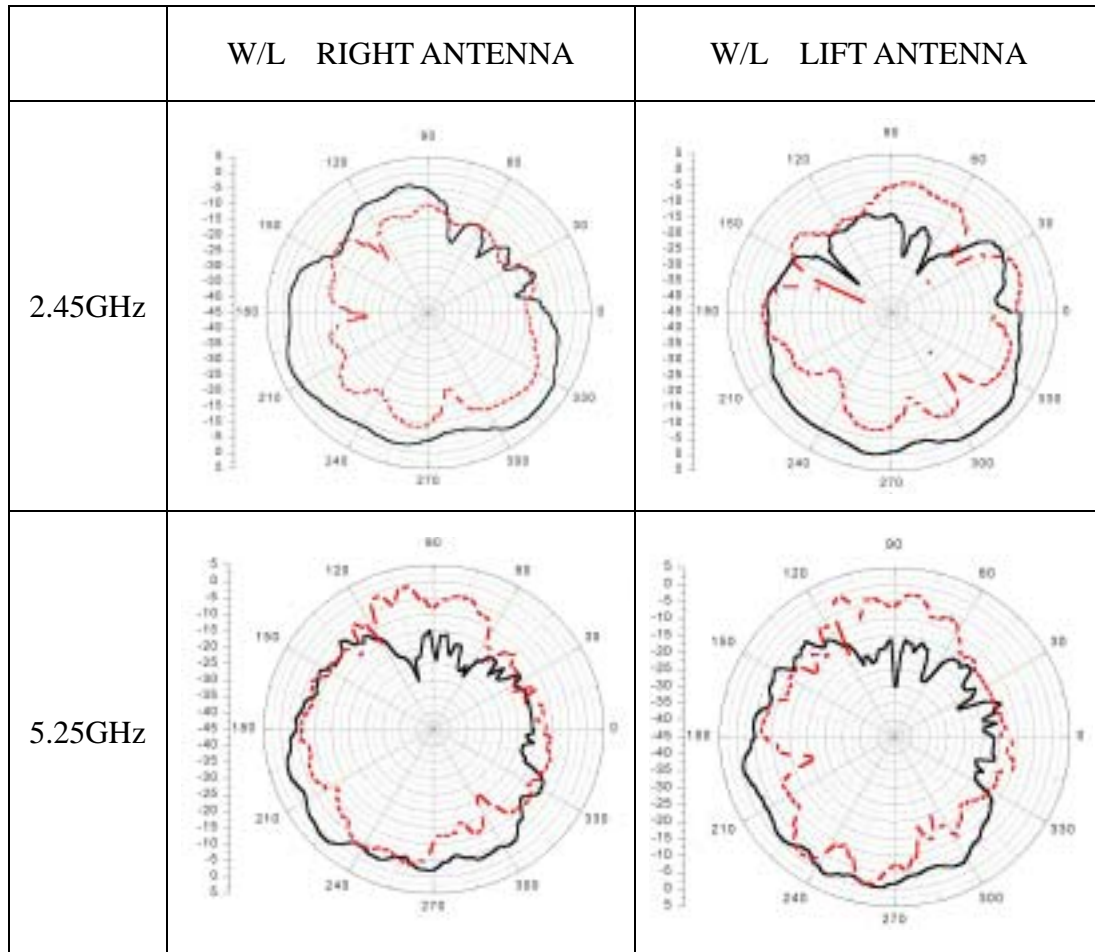

Average Gain & Peak Gain

項目 頻率	W/L RIGHT ANTENNA		W/L LIFT ANTENNA	
	Peak Gain (dBi)	Average Gain (dBi)	Peak Gain (dBi)	Average Gain (dBi)
2.45GHz	1.28	-3.55	1.04	-3.68
5.25GHz	-1.41	-4.36	-1.25	-4.61

- **Customer Drawing**

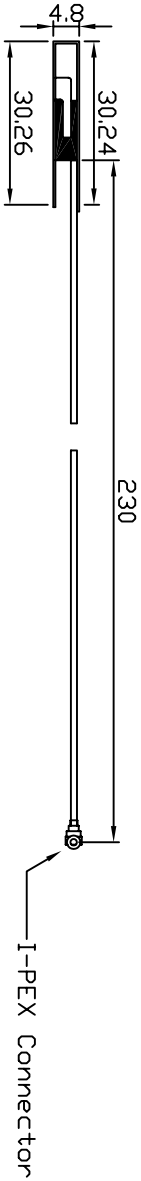
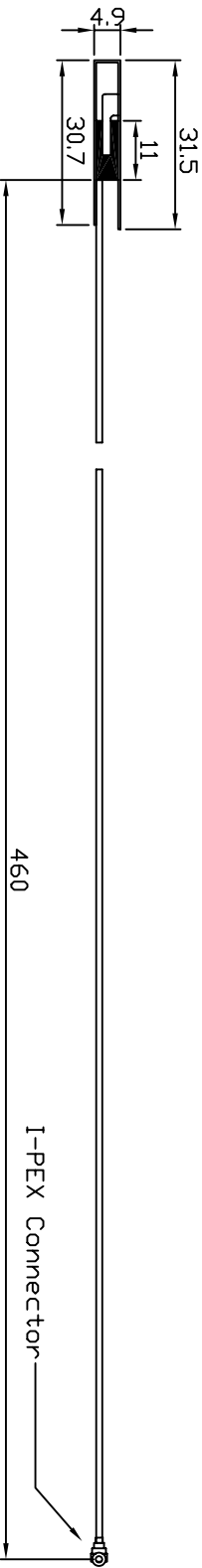

X ±		HannStar Electronics Corp. APPD: <i>Hans 01/28'03</i> CHKD:	DRAWING NAME: COMPAL BLC50 (WIRELESS)
.XX ±			
.XXX ±			
X° ±			
UNIT: mm (inch)		MATERIAL No.:	
SCALE: NONE		MA00017	
DR: <i>Allen 01/28'03</i>		SHEET:	
		REV:	

REV.	ECN NO.	APPD.

ED001-980729

This drawing contains information that is proprietary to HannStar Electronics Corp. And should not be used without written permission.

- **Cable – Hitachi**

SPECIFICATION

FOR

UL RECOGNIZED FEP INSULATED HIGH FREQUENCY COAXIAL CABLE

[P/N ;UL1745]

Quantity

Your Ref. No.

Our Ref. No.

Signed by *F. Shimizu*

Fumio Shimizu

Manager

Electronic Wire & Cable design department
Hitaka works, Electronic Supplies Group

Hitachi Cable, Ltd.

Issue and revision record

Rev. No.	Issue date	Item	Prepared by	Reviewed by	Approved by
—	Nov. 8, 2001	Initial issue	H. Tanaka	H.Ito	F. Shimizu
1	Nov. 16, 2001	<p>Revised Point [UL1745-SB CX-50 1×32AWG(7/0.08)D=1.13]</p> <ul style="list-style-type: none"> • Change Diameter of Insulation 0.66 → 0.68 • Outer conductor material is Changed tinned annealed copper wire ↓ Silver plated annealed copper wire • Construction of Outer conductor 5×16 → 4×16 • Change Diameter of Jacket 1.13±0.1 → 1.13^{+0.08}_{-0.05} • Nominal attenuation is changed [UL1745-SB CX-50 1×32AWG(7/0.08)D=1.32] • Change Diameter of Insulation 0.66 → 0.68 • Construction of Outer conductor 5×16 → 4×16 • Nominal attenuation is changed 	<p><i>N. Ono</i> N. Ono</p>	<p><i>H. Ito</i> H.Ito</p>	<p><i>F. Shimizu</i> F. Shimizu</p>

1. Scope

This specification covers UL recognized Fluoroethylene-propylene insulated high frequency coaxial cable.

[UL1745 : 90°C、30V]

Use : Internal wiring of Class 2 Circuits of Electronic Equipment.

2. Construction and Properties

HCL P/N	HCLI-TPE P/N	Construction and Properties
UL1745-SB CX-50 1×30AWG(1/0.26)D=1.25	RFX50-SS30-125	Table 1
UL1745-SB CX-50 1×30AWG(7/0.102)D=1.48	RFX50-SS30-148	
UL1745-SB CX-50 1×32AWG(7/0.08)D=1.13	RFX50-SS32-113	Table 2
UL1745-SB CX-50 1×32AWG(7/0.08)D=1.32	RFX50-SS32-132	
UL1745-DSB CX-50 1×32AWG(7/0.08)D=1.32	RFX50-DS32-132	Table 3
UL1745-SB CX-50 1×34AWG(7/0.064)D=0.98	RFX50-SS34-098	
UL1745-SB CX-50 1×36AWG(7/0.05)D=0.81	RFX50-SS36-081	

3. Marking

3.1 Marking on the wire

No marking on the wires.

3.2 Marking on the tag attached to reel

Each reel shall be tagged to show the following information with UL stamp.

- | | |
|----------------------|---------------------------|
| (1) UL Style | (8) File No. |
| (2) Conductor size | (9) Rating temperature |
| (3) No. of conductor | (10) Rating voltage |
| (4) Color | (11) Date of manufacture |
| (5) Lot No. | (12) Insulation thickness |
| (6) Length | (13) Name of manufacture |
| (7) Use | |

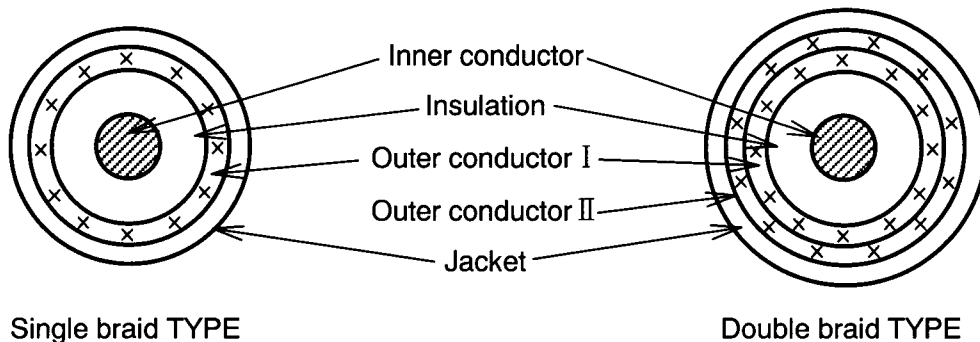

Fig.1 Cross-section of cable

Table 1 Construction and Properties (30AWG)

Item	Unit	Specified Value		
HCL P/N	—	UL1745-SB CX-50 1×30AWG(1/0.26)D=1.25	UL1745-SB CX-50 1×30AWG(7/0.102)D=1.48	
HCLI-TPE P/N	—	RFX50-SS30-125	RFX50-SS30-148	
Inner Conductor	Material	—	silver plated copper clad steel wire	
	AWG size	—	30	
	Stranding	No./mm	1/0.26	7/0.102
	Diameter	mm	0.26±0.008	0.30±0.03
	Number	—	1	
Insulation	Material	—	Fluoroethylene-propylene(FEP)	
	Thickness	mm	Nom. 0.27	Nom. 0.27
	Diameter	mm	0.80±0.05	0.84±0.06
	Color	—	natural	
Outer Conductor I	Material	—	Tinned annealed copper wire	silver plated annealed copper wire
	Form	—	braid	
	Strand	mm	0.05	0.08
	Construction	—	6×16	3×16
	Coverage	%	Min. 90	
	Diameter	mm	Nom. 1.05	1.24±0.07
Jacket	Material	—	Fluoroethylene-propylene(FEP)	Ethylene-tetrafluoroethylene(ETFE)
	Thickness	mm	Nom. 0.10	0.12
	Diameter	mm	1.25±0.13	1.48±0.08
	Color	—	Black, White, Red, Green, Yellow, Brown, Blue, Orange, Gray, Violet	
Unit length	m	305	100	
Package	—	paper reel	paper reel	
Approx. mass	kg/km	4.0	5.1	
Inner Conductor resistance at 20°C	Ω/km	Max. 844	Max. 832	
Dielectric strength*	—	A.C. 1000V for 1minute		
Insulation resistance* at 20°C	MΩ·km	Min. 1000		
Characteristic impedance by TDR	Ω	50±2		
Capacitance * at 1kHz	pF/m	Nom. 100	95±10	
Nominal attenuation	at 1GHz	dB/m	1.56	1.8
	at 2GHz	dB/m	2.3	2.5
	at 3GHz	dB/m	2.9	3.1
	at 4GHz	dB/m	3.5	4.1
	at 5GHz	dB/m	4.5	4.6
	at 6GHz	dB/m	5.2	5.3

* Between inner conductor and outer conductor

Table 2 Construction and Properties (32AWG)

Item		Unit	Specified Value		
HCL P/N		—	UL1745-SB CX-50 1×32AWG(7/0.08)D=1.13	UL1745-SB CX-50 1×32AWG(7/0.08)D=1.32	UL1745-DSB CX-50 1×32AWG(7/0.08)D=1.32
HCLI-TPE P/N		—	RFX50-SS32-113	RFX50-SS32-132	RFX50-DS32-132
Inner Conductor	Material	—	silver plated annealed copper wire		
	AWG size	—	32		
	Stranding	No./mm	7/0.08		
	Diameter	mm	0.24		
	Number	—	1		
Insulation	Material	—	Fluoroethylene-propylene(FEP)		
	Thickness	mm	Nom. 0.21		
	Diameter	mm	0.68 ^{+0.04} _{-0.02}		
	Color	—	Natural		
Outer Conductor I	Material	—	Silver plated annealed copper wire	Tinned annealed copper wire	
	Form	—	Braid		
	Strand	mm	0.05		
	Construction	—	4×16		
	Coverage	%	Min. 90		
	Diameter	mm	Nom. 0.88		
Outer Conductor II	Material	—	—	Tinned annealed copper wire	
	Form	—	—	braid	
	Strand	mm	—	0.05	
	Construction	—	—	6×16	
	Coverage	%	—	Min. 90	
	Diameter	mm	—	Nom. 1.12	
Jacket	Material	—	Fluoroethylene-propylene(FEP)		
	Thickness	mm	Nom. 0.125	Nom. 0.22	Nom. 0.10
	Diameter	mm	1.13 ^{+0.08} _{-0.05}	1.32 (Max. 1.45)	1.32±0.1
	Color	—	Black, White, Red, Green, Yellow, Brown, Blue, Orange, Gray, Violet		
Unit length	m	305			200
Package	—	paper reel			Coil
Approx. mass	kg/km	4.0			5.0
Inner Conductor resistance at 20°C	Ω/km	Max. 597			
Dielectric strength*	—	A.C. 500V for 1minute			
Insulation resistance* at 20°C	MΩ·km	Min. 1000			
Characteristic impedance by TDR	Ω	50±2			
Capacitance * at 1kHz	pF/m	Nom. 95			
Nominal attenuation	at 1GHz	dB/m	2.0		
	at 2GHz	dB/m	2.9		
	at 3GHz	dB/m	3.6		
	at 4GHz	dB/m	4.2		
	at 5GHz	dB/m	4.7		
	at 6GHz	dB/m	5.2		

* Between inner conductor and outer conductor

Table 3 Construction and Properties (34AWG, 36AWG)

Item		Unit	Specified Value	
HCL P/N		—	UL1745-SB CX-50 1×34AWG(7/0.064)D=0.98	UL1745-SB CX-50 1×36AWG(7/0.05)D=0.81
HCLI-TPE P/N		—	RFX50-SS34-098	RFX50-SS36-081
Inner Conductor	Material	—	silver plated annealed copper wire	
	AWG size	—	34	36
	Stranding	No./mm	7/0.064	7./0.05
	Diameter	mm	0.192	0.15
	Number	—	1	
Insulation	Material	—	Fluoroethylene-propylene(FEP)	
	Thickness	mm	Nom. 0.169	Nom. 0.125
	Diameter	mm	0.53	0.4 ^{+0.04} _{-0.02}
	Color	—	natural	
Outer Conductor I	Material	—	Tinned annealed copper wire	silver plated annealed copper wire
	Form	—	braid	
	Strand	mm	0.05	
	Construction	—	4×16	3×16
	Coverage	%	Min. 90	
	Diameter	mm	Nom. 0.78	Nom. 0.65
Jacket	Material	—	Fluoroethylene-propylene(FEP)	Perfluoroalkoxy(PFA)
	Thickness	mm	Nom. 0.10	Nom. 0.08
	Diameter	mm	0.98 (Max. 1.1)	0.81 ^{+0.04} _{-0.02}
	Color	—	Black, White, Red, Green, Yellow, Brown, Blue, Orange, Gray, Violet	
Unit length	m	305	305	
Package	—	paper reel	paper reel	
Approx. mass	kg/km	2.4	1.6	
Inner Conductor resistance at 20℃	Ω/km	Max. 868	Max. 1400	
Dielectric strength*	—	A.C. 500V for 1minute	A.C. 1000V for 1minute	
Insulation resistance* at 20℃	MΩ-km	Min. 1500	Min. 1000	
Characteristic impedance by TDR	Ω	50±5	50±3	
Capacitance * at 1kHz	pF/m	Nom. 100	Nom. 100	
Nominal attenuation	at 1GHz	dB/m	2.6	3.1
	at 2GHz	dB/m	3.9	4.7
	at 3GHz	dB/m	5.0	5.8
	at 4GHz	dB/m	6.1	6.9
	at 5GHz	dB/m	7.0	8.2
	at 6GHz	dB/m	7.9	9.4

* Between inner conductor and outer conductor

- **Cable – HannStar**



東莞瀚宇電子有限公司

DONGGUAN HANNSTAR ELECTRONICS CO.,LTD

CABLE SPECIFICATION(線材規格書)

Messrs	HNS		樣品編號	DGHNS-8-1
Standard	RG-178 #32X1C			
Item (項目)		Unit	Specification(規格值)	
Awg(線規)		Awg	#32	
No.of conductor(芯線數)		p,c	1C	
Conductor 導體	Material(材質)	---	Silver Plated Copper	
	Filler (填充)	---	-----	
	Construction(結構)	No./mm	7/0.08	
	Stranded diameter(絞合外徑)	mm	0.24	
Insulation 絕緣	Material(材質)	---	FEP	
	Nom. Thickness(厚度)	mm	0.235	
	Diameter(線徑)	mm	0.71+0.05	
	Color(顏色)	---	Nature	
Tape 包帶	Material(材質)	---	----	
	Over Lapping(重疊率)	%	----	
Drain Wire 地線	Material(材質)	---	-----	
	Construction(結構)	No./mm	-----	
Braid Shield 編織	Material(材質)	---	Silver Plated Copper	
	Coverage(遮蔽率)	%	90	
Jacket 外被	Material(材質)	---	FEP	
	Nom. Thickness(厚度)	mm	0.11	
	O.D(外徑)	mm	1.13+0.08-0.04	
	Color(顏色)	---	Nature	
Marking 印字	-----			

Configuration:

(結構圖)

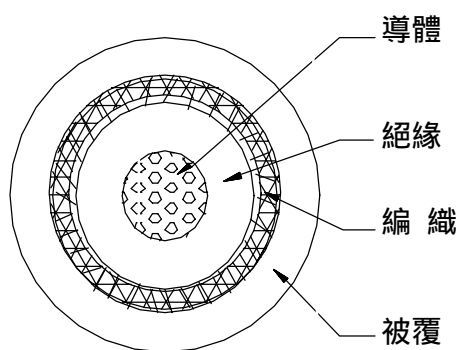



東莞瀚宇電子有限公司

DONGGUAN HANNSTAR ELECTRONICS CO., LTD

CABLE SPECIFICATION(線材規格書)

Messrs	HNS	樣品 編號	DGHNS-8-1
Standard	RG-178 #32X1C		

Electric Characters:

(電氣特性)

Testing item(測試項目)	32AWG	
Conductor resistance(導體電阻)	<=597 /km	
Impedance(特性阻抗)	50+4-0	
Dielectric strength(耐電壓)	A.C 500V/分	
Insulation resistance	>=1000M /Km	
Attenuation(maximum)	Frequency(GHZ)	dB/M
	1	2
	2	2.9
	3	3.8
	4	4.4
	5	5.0
	6	5.6

RATIFY 核准	龔余良2002.10.09	APPROVED 審核	-----	DESIGN 設計	PENG10/09
--------------	---------------	----------------	-------	--------------	-----------

- **Cable – AXON**

SPECIFICATION OF COAX 50 Ohms AWG32 D=1.13 mm	AXON' CABLE S.A.S. <i>CABLE & INTERCONNECT</i> ROUTE DE CHALONS-SUR-MARNE 51210 MONTMIRAIL-FRANCE	Jorjin Technologies Inc. 9F-4,NO.160,Sec.6,Min Chuan E. Rd.,Taipei, Taiwan, R.O.C. Te l :886-2-27953660 Fax :886-2-27954006 e-mail :kc_hung@jorjin.com.tw
--	---	---

I – Scope

This specification presents a FEP jacketed COAXIAL cable AWG32, 1.13 mm O.D.for internal wiring of electronic equipment, such as Computer / Notebook with wireless communication systems.

II – Construction

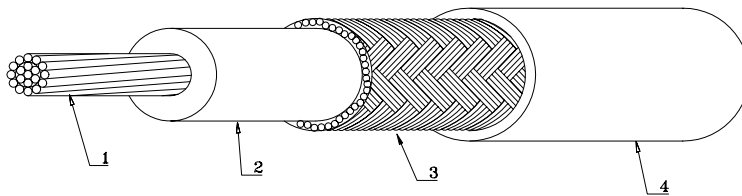

Item	Unit	Details
1-Inner Conductor	Material	- Silver Plated Copper
	Composition	No./mm AWG32 or 7 x 0.079
	Nom. O.D.	mm 0.237
2-Dielectric	Material	- Extruded PTFE
	Nom. O.D.	mm 0.68
	Color	- Natural
3-Outer Conductor	Material	- Silver Plated Copper
	Composition	- Braided Shield AWG44
	Approx. O.D.	mm 0.90
5-Outer Jacket	Material	- Extruded FEP
	O.D. (mm)	mm 1.13±0.05
	Color	- Light Grey

III – Characteristics

Item	Unit	Nom. Value
Inner Conductor resistance @20°C	Ω/km	525
Characteristic Impedance	Ω	50±2
Capacitance	PF/m	98
Max. Attenuation (dB/m)	@ 1.0 GHz	1.8
	@ 2.45 GHz	3.0
	@ 5.2 GHz	4.6
	@ 5.8 GHz	5.0
Temperature Rating	°C	150
Approx. Weight	g/m	3.15

- **I-PEX Connector**

PRODUCT SPECIFICATION

製品規格

No. PRS-1176

MHF series micro coaxial connector

Qualification Test Report No. TR-1021

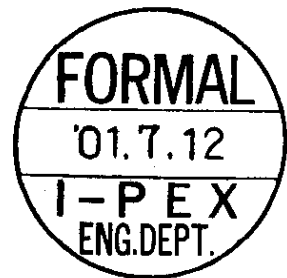

					Prepared by	Reviewed by	Approved by
0	S1025	K.o	JUN/25/01		K. Ohbayashi	E Kawabe	K. Kobayashi
REV.	ECN	BY	DATE	APP.	JUN/25/01	JUN/25/01	JUN/29/01
REVISION RECORD							

DOCUMENT CLASSIFICATION	TITLE	No.
Product Specification 製品規格	MHF series micro coaxial connector	PRS-1176
<p>1. Scope / 序言 MHF series micro coaxial connector is a wire to board connector for AWG#36,32,30 coaxial cable . MHF series micro coaxial connector は、AWG # 36,32,30同軸ケーブルの基板対ワイヤーコネクタである。</p> <p>2. Objectives / 目的 This specification covers the requirements for product performance and test methods of MHF series microcoaxial connector 本規格は、MHF series micro coaxial connector の性能と試験条件について規定する。</p> <p>3. Part No. , construction , material and finish / 構成、材料及び仕上げ (1) Part No. Plug : 20278-001R-08,-13,-18 , Receptacle : 20279-001E-01 (2) Construction, material and finish of the connector are covered as each drawings. 構成、材料及び仕上げは、各図面に指定されている通りとする。</p> <p>4. Applicable cable / 適合ケーブル 4-1 Part No. 20278-001R-08 (1) Description Inner conductor : AWG#36(7/0.05) sliver plating annealed copper wire or sliver plating tin-copper alloy Dielectric core : Fluoro-plastics ,diameter 0.4(+0.04,-0.02)mm , nominal thickness 0.125mm Outer conductor : 8/5/0.05 , nominal diameter 0.65mm , sliver plating annealed copper wire Jacket : Fluoro-plastics , diameter 0.81(+0.04,-0.02)mm , nominal thickness 0.08mm (2) Requirements Characteristic impedance : 50(+3,-3)ohm by TDR method (raise time 40ps) Nominal capacitance: 96 pF/m Conductor resistance of inner conductor at 293K (20°C) : 1400 ohm/m MAX. Insulation resistance : 1000 mega-ohm.km MIN. Dielectric withstand voltage : no breakdown at AC1000V for 1 minutes.</p> <p>(1) 構成 中心導体 : AWG # 36 (7 / 0.05) , 銀メッキ軟銅線または銀メッキすず入り銅線 誘電体 : フッ素樹脂, 外径0.4(+0.04,-0.02), 標準厚さ0.125mm 外部導体 : 8 / 5 / 0.05, 標準外径0.65mm, 銀メッキ軟銅線 ジャケット : フッ素樹脂, 外径0.81(+0.04,-0.02)mm, 標準厚さ0.08mm</p> <p>(2) 仕様 特性インピーダンス : 50±3Ω (TDR,ライズタイム40ps) 標準静電容量 : 96pF/m 293K(20°C)時の中心導体導体抵抗 : 1400Ω/m以下 絶縁抵抗 : 1000MΩ・km以上 耐電圧 : AC1000V・1分間にて絶縁破壊の無い事</p> <p>4-2 Part No. 20278-001R-13 (1) Description Inner conductor : AWG#32(7/0.08) sliver plating annealed copper wire or sliver plating tin-copper alloy Dielectric core : Fluoro-plastics , diameter 0.68(+0.04,-0.02)mm , nominal thickness 0.22mm Outer conductor : 16/4/0.05 , nominal diameter 0.93mm , sliver plating annealed copper wire Jacket : Fluoro-plastics , diameter 1.13(+0.08,-0.05)mm , nominal thickness 0.1mm</p>		

DOCUMENT CLASSIFICATION	TITLE	No.
Product Specification 製品規格	MHF series micro coaxial connector	PRS-1176
<p>(2) Requirements Characteristic impedance : 50(+2,-2)ohm by TDR method (raise time 40ps) Nominal capacitance: 97 pF/m Conductor resistance of inner conductor at 293K (20°C) : 520 ohm/m MAX. Insulation resistance : 1500 mega-ohm.km MIN. Dielectric withstand voltage : no breakdown at AC1000V for 1 minutes.</p> <p>(1) 構成 中心導体 : AWG # 32 (7 / 0.08), 銀メッキ軟銅線または銀メッキすず入り銅線 誘電体 : フッ素樹脂, 外径 0.68 (+0.04, -0.02), 標準厚さ 0.22mm 外部導体 : 16 / 4 / 0.05, 標準外径 0.93mm, 銀メッキ軟銅線 ジャケット : フッ素樹脂, 外径 1.13 (+0.08, -0.05)mm, 標準厚さ 0.1mm</p> <p>(2) 仕様 特性インピーダンス : 50 ± 2 Ω (TDR, ライズタイム 40ps) 標準静電容量 : 97pF/m 293K (20°C) 時の中心導体導体抵抗 : 520 Ω / m 以下 絶縁抵抗 : 1500MΩ · km 以上 耐電圧 : AC1000V · 1分間にて絶縁破壊の無い事</p> <p>4-3 Part No. 20278-001R-18 RG178 B/U</p> <p>(1) Description Inner conductor : AWG#30(7/0.102), silver plating copper clad steel wire Dielectric core : Fluoro-plastics, diameter 0.84(+0.03,-0.03)mm, nominal thickness 0.268mm Outer conductor : 16/3/0.1, nominal diameter 1.35mm, silver plating copper wire Jacket : Fluoro-plastics, diameter 1.8(+0.1,-0.1)mm, nominal thickness 0.23mm</p> <p>(2) Requirements Characteristic impedance : 50(+2,-2)ohm by TDR method (raise time 40ps) Nominal capacitance: 95 pF/m Conductor resistance of inner conductor at 293K (20°C) : 805 ohm/m MAX. Insulation resistance : 1500 mega-ohm.km MIN. Dielectric withstand voltage : no breakdown at AC2000V for 1 minutes.</p> <p>(1) 構成 中心導体 : AWG # 30 (7 / 0.102), 銀メッキ銅被鋼線 誘電体 : フッ素樹脂, 外径 0.84 (± 0.03), 標準厚さ 0.268mm 外部導体 : 16 / 3 / 0.1, 標準外径 1.35mm, 銀メッキ軟銅線 ジャケット : フッ素樹脂, 外径 1.8 (± 0.1)mm, 標準厚さ 0.23mm</p> <p>(2) 仕様 特性インピーダンス : 50 ± 2 Ω (TDR, ライズタイム 40ps) 標準静電容量 : 95pF/m 293K (20°C) 時の中心導体導体抵抗 : 805 Ω / m 以下 絶縁抵抗 : 1500MΩ · km 以上 耐電圧 : AC2000V · 1分間にて絶縁破壊の無い事</p> <p>5. Ratings / 定格 (1) Rated voltage / 電圧 : AC60Vrms (2) Nominal characteristic impedance / 公称特性インピーダンス : 50 Ω (3) Frequency / 周波数 : DC ~ 3GHz (4) VSWR : 1.3 MAX. (5) Service Temperature / 使用温度範囲 : 233 ~ 363K (-40 ~ +90°C)</p>		

DOCUMENT CLASSIFICATION	TITLE	No.
Product Specification 製品規格	MHF series micro coaxial connector	PRS-1176

6. Test methods and performance / 試験及び性能

6-1 Test condition / 試験条件

Unless otherwise specified, all tests and measurements shall be performed under the following conditions in accordance with MIL-STD-202

全ての測定と試験は、MIL-STD-202に基づき以下の条件で行う。

Temperature / 温度 : 288~308K (15~35°C)

Humidity / 湿度 : 45~75%RH

6-2 Sample quantity / 試料数

- (1) Insulation resistance / 絶縁抵抗 : 10pcs.
- (2) Dielectric withstanding voltage / 耐電圧 : 10pcs.
- (3) VSWR : 5pcs.
- (4) Mating & unmating force / 挿抜力 : 10pcs
- (5) Durability / 耐久性 : 10pcs.
- (6) Cable retention force / ケーブル保持力 : 10pcs.
- (7) Vibration / 振動 : 10pcs.
- (8) Shock / 衝撃 : 10pcs.
- (9) Thermal shock / 温度サイクル : 10pcs.
- (10) Humidity / 湿度 : 10pcs.
- (11) Salt water spray / 塩水噴霧 : 10pcs.
- (12) Solderability / 半田付け性 : 10pcs.
- (13) Reflow soldering heat resistance / 半田耐熱性 : 10pcs.

6-3-1 Electrical / 電氣的性能

(1) Contact Resistance / 接触抵抗

A. Testing: Solder the receptacle connector to the test board and mate the plug connector together, then measure the contact resistance as shown in Fig.1 by the four terminal method.

Apply the low level condition in accordance with MIL-STD-202, Method 307.

Open circuit voltage : 20mV MAX

Circuit current : 10mA MAX. (DC or AC1kHz)

Contact resistance of inner contact : <resistance of A-E> - <resistance of B-E>

Contact resistance of ground contact : <resistance of A-D> - <resistance of B-D>

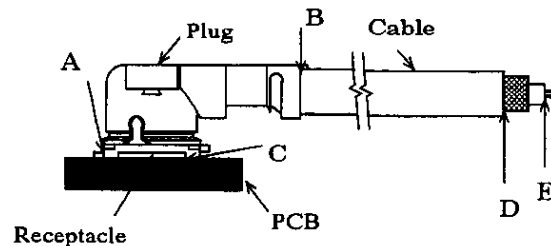

Fig.1

B. Requirements :

Contact resistance of inner contact initial 20 milli-ohm MAX. after testing 25milli-ohm MAX.

Contact resistance of ground contact initial 10 milli-ohm MAX. after testing 15milli-ohm MAX.

DOCUMENT CLASSIFICATION	TITLE	No.
Product Specification 製品規格	MHF series micro coaxial connector	PRS-1176

A. 試験法: テスト基板にリセプタクルコネクタを半田付けし、プラグコネクタと嵌合させ、Fig. 1のように4端子法にて下記の条件で測定する。MIL-STD-202 試験法 307 に準拠。

開回路電圧: 20mV以下

試験電流 : 10mA (DCもしくはAC1kHz)

中心導体 : <A-E間の電気抵抗> - <B-E間の電気抵抗>

外部導体 : <A-D間の電気抵抗> - <B-D間の電気抵抗>

B. 必要条件: 中心導体 初期 20mΩ 以下, 試験後 25mΩ 以下

外部導体 初期 10mΩ 以下, 試験後 15mΩ 以下

(2) Insulation resistance / 絶縁抵抗

A. Testing : Mate the plug and receptacle connector together, then apply DC 100 V between the inner contact and the ground contact in accordance with MIL-STD-202, Method 302.

B. Requirements : Initial 500 Mohm MIN. after testing 100 Mohm MIN.

A. 試験法: リセプタクル及びプラグコネクタを互いに嵌合させ、中心導体と外部導体の間に DC 100Vを印加し、測定する。MIL-STD-202 試験法 302 に準拠。

B. 必要条件: 初期 500MΩ 以上 試験後 100MΩ 以上

(3) Dielectric withstanding voltage / 耐電圧

A. Testing : Mate the receptacle and plug connector together, then apply AC 200 Vrms between the inner contact and the ground contact for a minute in accordance with MIL-STD-202, Method 301.

B. Requirements : No creeping discharge, flashover, nor insulator breakdown shall occur.

A. 試験法: リセプタクル及びプラグコネクタを互いに嵌合させ、中心導体と外部導体の間に AC 200V(実効値)を一分間印加する。MIL-STD-202 試験法 301 に準拠。

B. 必要条件: 浴面放電、空中放電、絶縁破壊等の異常のないこと。

(4) VSWR

A. Testing : Measure the VSWR as shown in Fig.3 by the network analyzer.

Frequency : 100M~3GHz

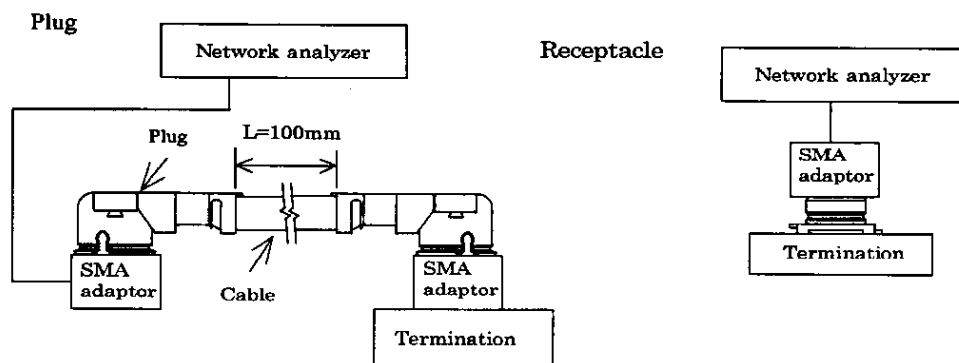

Fig.3

B. Requirements : 1.3 MAX.

A. 試験法: ネットワークアナライザーにて Fig.3 のようにVSWRを測定する。

周波数 : 100M~3GHz

B. 必要条件: 1.3以下

DOCUMENT CLASSIFICATION	TITLE	No.
Product Specification 製品規格	MHF series micro coaxial connector	PRS-1176

6-3-2 Mechanical / 機械的性能

(1) Mating & unmating force / 挿抜力

A. Testing : Mate and unmate the receptacle connector (soldered to the test board) and plug at a speed 25 ± 3 mm/minutes along the mating by the push-on/pull-off machine .

B.Requirements :

Total mating force : Initial 20N MAX. after 30 cycles 15N MAX.

Total unmating force : Initial 5N MIN. after 30 cycles 3N MIN.

Unmating force of inner contact : Initial 0.15N MIN. after 30 cycles 0.1N MIN

A.試験法:挿抜試験機を用いて、基板に半田付けしたリセプタクルとプラグを嵌合軸と平行に毎分 25 ± 3 mmの速度で挿抜する。

B.必要条件:

総合挿抜力:初回挿入力 20N以下 30回後15N以下 ,初回抜去力 5N以上 ,30回後抜去力 3N以上

中心導体 :初回抜去力 0.15N以上 ,30回後抜去力 0.1N以上

(2) Durability / 耐久性

A. Testing : Mate and unmate the receptacle connector (soldered to the test board) and plug 30 cycles at a speed 25 ± 3 mm/minutes along the mating by the push-on/pull-off machine .

B.Requirements :

Contact resistance of inner contact initial 20 milli-ohm MAX. after testing 25milli-ohm MAX.

Contact resistance of ground contact initial 10 milli-ohm MAX. after testing 15milli-ohm MAX.

A.試験法:挿抜試験機を用いて、基板に半田付けしたリセプタクルとプラグを嵌合軸と平行に毎分 25 ± 3 mmの速度で30回挿抜する。

B.必要条件 中心導体接触抵抗 : 初期 20mΩ 以下, 試験後 25mΩ 以下

外部導体接触抵抗 : 初期 10mΩ 以下, 試験後 15mΩ 以下

(3) Cable retention force / ケーブル保持力

A. Testing : Apply force on the cable as shown in Fig.2.

During the testing, run 100mA DC to check electrical discontinuity.

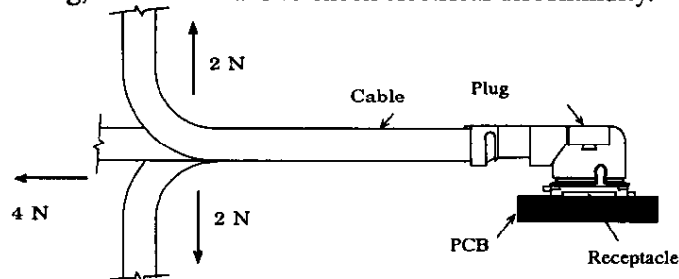

Fig.2

B.Requirements

Appearance : Looseness between the parts, chipping, breakage or other abnormality shall not occur.

Electrical discontinuity : No electrical discontinuity greater than 1 micro-sec. shall occur.

Contact resistance of inner contact initial 20 milli-ohm MAX. after testing 25milli-ohm MAX.

Contact resistance of ground contact initial 10 milli-ohm MAX. after testing 15milli-ohm MAX.

A.試験法:Fig. 2のようにケーブルに力を加える。尚、試験中にDC100mAの電流を流して電氣的瞬断を確認する。

B.必要条件 外観 : 部品のゆるみ、欠け、割れ、その他外観上の異常の無いこと。

電流瞬断 : 試験中、1 マイクロ秒を超える電氣的瞬断の無いこと。

中心導体接触抵抗 : 初期 20mΩ 以下, 試験後 25mΩ 以下

外部導体接触抵抗 : 初期 10mΩ 以下, 試験後 15mΩ 以下

DOCUMENT CLASSIFICATION Product Specification 製品規格	TITLE MHF series micro coaxial connector	No. PRS-1176
<p>(4) Vibration / 振動</p> <p>A. Testing : Apply the following vibration to the mating connector . During the testing, run 100mA DC to check electrical discontinuity. Frequency : 10Hz → 100Hz → 10Hz / approx 15 minutes. Half amplitude ,Peak value of acceleration: 1.5mm or 59m/s² (6G) Directions , cycle : 3 mutually perpendicular direction , 5 cycles(approx 75min)about each direction</p> <p>B.Requirements Appearance : Looseness between the parts, chipping, breakage or other abnormality shall not occur. Electrical discontinuity : No electrical discontinuity grater than 1micro-sec. shall occur. Contact resistance of inner contact initial 20 milli-ohm MAX. after testing 25milli-ohm MAX. Contact resistance of ground contact initial 10 milli-ohm MAX. after testing 15milli-ohm MAX.</p> <p>A.試験法:嵌合状態のコネクタを、下記の振動を加える。尚、試験中にDC100mAの電流を流して電氣的瞬断を確認する。 周波数 : 10Hz→100Hz→10Hz / 約15分間 片振幅,加速度: 1.5mm or 59m/s² (6G) 方向,サイクル:3つの互いに直角な方向について各5サイクル(約75分)実施</p> <p>B.必要条件 外観 : 部品のゆるみ、欠け、割れ、その他外観上の異常の無いこと。 電流瞬断 : 試験中、1マイクロ秒を超える電氣的瞬断の無いこと。 中心導体接触抵抗 : 初期 20mΩ 以下、試験後 25mΩ 以下 外部導体接触抵抗 : 初期 10mΩ 以下、試験後 15mΩ 以下</p> <p>(5) Shock / 衝撃</p> <p>A. Testing : Apply the following vibration to the mating connector in accordance with MIL-STD-202, Method 213, Condition B. During the testing, run 100mA DC to check electrical discontinuity. Peak value of acceleration: 735m/s² (75G) Duration : 11msec Wave Form : half sinusoidal Directions , cycle : 6 mutually perpendicular direction , 3 cycles about each direction</p> <p>B.Requirements Appearance : Looseness between the parts, chipping, breakage or other abnormality shall not occur. Electrical discontinuity : No electrical discontinuity grater than 1 micro-sec. shall occur. Contact resistance of inner contact initial 20 milli-ohm MAX. after testing 25milli-ohm MAX. Contact resistance of ground contact initial 10 milli-ohm MAX. after testing 15milli-ohm MAX.</p> <p>A.試験法:嵌合状態のコネクタを、衝撃試験機に取り付け、下記の衝撃を加える。尚、試験中にDC100mAの電流を流して電氣的瞬断を確認する。MIN-STD-202 試験法 213 試験条件 B に準拠。 最大加速度: 735m/s²(75G) 標準持続時間: 11msec. 波形: 半波正弦波 方向: 直交する6方向、各3回</p> <p>B.必要条件 外観 : 部品のゆるみ、欠け、割れ、その他外観上の異常の無いこと。 電流瞬断 : 試験中、1マイクロ秒を超える電氣的瞬断の無いこと。 中心導体接触抵抗 : 初期 20mΩ 以下、試験後 25mΩ 以下 外部導体接触抵抗 : 初期 10mΩ 以下、試験後 15mΩ 以下</p>		

DOCUMENT CLASSIFICATION	TITLE	No.
Product Specification 製品規格	MHF series micro coaxial connector	PRS-1176
<p>6-3-3 Environmental / 耐環境性</p> <p>(1) Thermal shock/ 温度サイクル</p> <p>A. Testing : Apply the following environment to the mating connector .</p> <p>Temperature ,duration :233K/30minutes→278~308K/5minutes MAX.→363K/30minutes→278~308K/5minutes MAX. (-40°C) (5~35°C) (90°C) (5~35°C)</p> <p>No. of cycles : 5 cycles</p> <p>B.Requirements Appearance : Looseness between the parts, chipping, breakage or other abnormality shall not occur. Contact resistance of inner contact initial 20 milli-ohm MAX. after testing 25milli-ohm MAX. Contact resistance of ground contact initial 10 milli-ohm MAX. after testing 15milli-ohm MAX. Insulation resistance : initial 500 mega-ohm MIN. after testing 100 mega-ohm MIN.</p> <p>A.試験法: 嵌合状態のコネクタを、下記の雰囲気放置在する。 1サイクルの条件 :233K/30分→278~308K/5分以下→363K/30分→278~308K/5分以下 (-40°C) (5~35°C) (90°C) (5~35°C) 実施サイクル :5サイクル</p> <p>B.必要条件 外観 : 部品のゆるみ、欠け、割れ、その他外観上の異常の無いこと。 中心導体接触抵抗 : 初期 20mΩ 以下, 試験後 25mΩ 以下 外部導体接触抵抗 : 初期 10mΩ 以下, 試験後 15mΩ 以下 絶縁抵抗 : 初期 500MΩ 以上 試験後 100MΩ 以上</p> <p>(2) Humidity / 湿度</p> <p>A. Testing : Apply the following environment to the mating connector in accordance with MIL-STD-202, Method 103, Condition B .</p> <p>Temperature : 313±2 K (40±2°C) Humidity : 90~95%RH Duration : 96 hours</p> <p>B.Requirements Appearance : Looseness between the parts, chipping, breakage or other abnormality shall not occur. Contact resistance of inner contact initial 20 milli-ohm MAX. after testing 25milli-ohm MAX. Contact resistance of ground contact initial 10 milli-ohm MAX. after testing 15milli-ohm MAX. Insulation resistance : initial 500 mega-ohm MIN. after testing 100 mega-ohm MIN.</p> <p>A.試験法: 嵌合状態のコネクタを、下記の雰囲気放置在する。MIL-STD-202 試験法 103 条件 B に準拠。 温度: 313±2K (40±2°C) 湿度: 90~95%RH 時間: 96時間</p> <p>B.必要条件 外観 : 部品のゆるみ、欠け、割れ、その他外観上の異常の無いこと。 中心導体接触抵抗 : 初期 20mΩ 以下, 試験後 25mΩ 以下 外部導体接触抵抗 : 初期 10mΩ 以下, 試験後 15mΩ 以下 絶縁抵抗 : 初期 500MΩ 以上 試験後 100MΩ 以上</p>		

DOCUMENT CLASSIFICATION Product Specification 製品規格	TITLE MHF series micro coaxial connector	No. PRS-1176
--	--	-----------------

(3) Salt water spray / 塩水噴霧

A. Testing : Apply the following environment to the mating connector in accordance with MIL-STD-202, Method 101, Condition B.

Temperature : 308 ± 2 K (35 ± 2 °C)

Salt water density by weight : 5 ± 1 %

Duration : 48 hours

B.Requirements : Appearance no abnormality adversely affecting the performance shall occur.

A.試験法: 嵌合状態のコネクタを、下記の雰囲気中に放置する。

温度 : 308 ± 2 K (35 ± 2 °C)

塩水濃度: 5 ± 1 % (重量比)

時間 : 48時間

B.必要条件 : 外観 著しい腐食の無い事。

6-3-4 Solder / 半田付け関連

(1) Solderability / 半田付け性

A. Testing : Dip the solder tine of the contact in the solder bath at 518 ± 5 (245 ± 5 °C) for 5 ± 0.5 sec.

After immersing the tine in the flux of RMA or R type for 5 to 10 seconds in accordance with MIL-STD-202, Method 208.

B.Requirements : More than 95% of the dipped surface shall be evenly wet.

A.試験法: コントクトの半田付け部を 518 ± 5 K (245 ± 5 °C)の半田槽内に 5 ± 0.5 秒浸す。フラックスは、RMA 又は R 型を使用し 5~10 秒間浸すものとする。MIL-STD-202, 試験法 208 に準拠。

B.必要条件: 浸した面積の 95%以上に半田がむらなく付着すること。

(2) Reflow soldering heat resistance / 半田耐熱性

A. Testing : Put on the receptacle connector to PCB , apply the heat 2 cycles as shown in Fig. 4

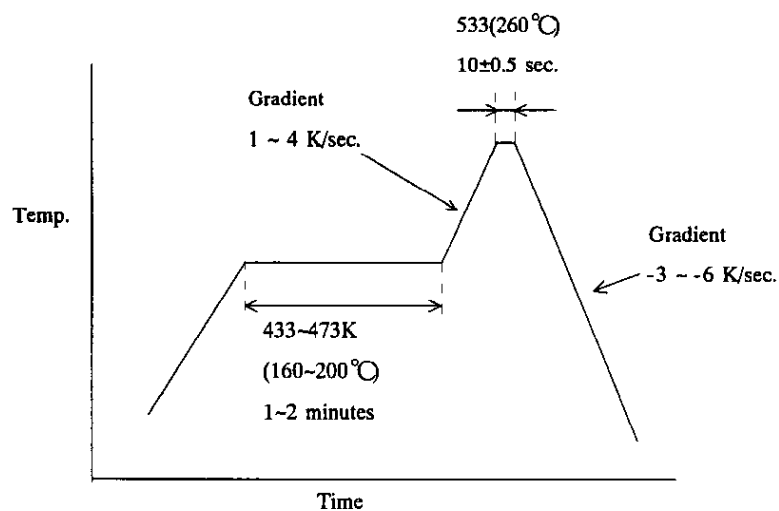

Fig.4

B.Requirements : Appearance no abnormality adversely affecting the performance shall occur.

A.試験法: 基板にリセプタクルコネクタを置き、Fig. 4の条件で2回リフローを行う。

B.必要条件: 機能を損なう変形及び欠陥の無い事。

- **Sponge**

Notes

1. Material
 - (1) Housing : PBT, UL94V-0, black
 - (2) Contact phosphor bronze gold plating
 - (3) Ground contact phosphor bronze, gold plating
2. Packing : reel
 3. Mating partner part No. : 20279-001E-01

1. 材料
 - (1) ハウジング : PBT, UL94V-0, 黒色
 - (2) コンタクト : 銅鍍金
 - (3) グランドコネクタ : 銅鍍金
2. 梱包 : リール
 3. かん合相手 part No. : 20279-001E-01

4. Permissible load of cable at mating

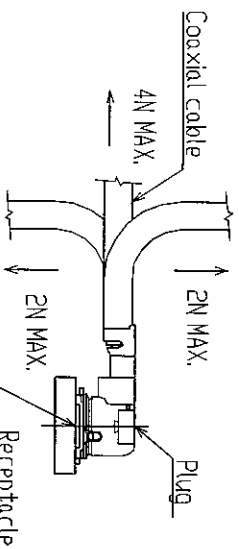

コネクタかん合後のケーブルに対する荷重

5. Suggestions for mating & unmating operation.

5-1 Mating.
Please mate the connector straightly to vertical direction as much as possible, adjusting the mating axis of plug and receptacle.
As excessive slant angle mating may break the connector, please don't do it.

5. コネクタかん合時および抜き時の注意

5-1 コネクタ挿入時
PlugとReceptacleのかん合軸を合わせ、できるだけ垂直に挿入して下さい。
傾斜な斜め挿入は行わないで下さい。
コネクタ破損の原因となりますので、過度なこじり抜きは行わないで下さい。

5-2 Unmating.

(1) In case of unmating by pulling tool.
Please use the pulling drawing tool as the following drawing, and please pull plug to vertical direction as directly as possible.

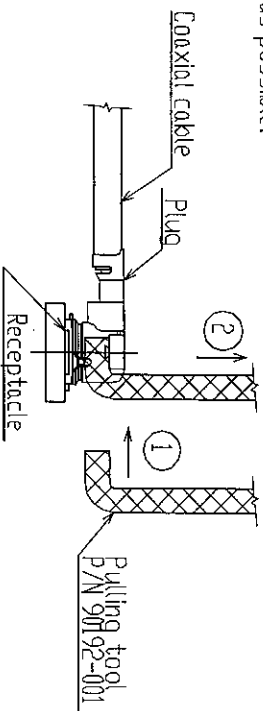

5-2 コネクタ抜き時

(1) 抜きシグを用いる場合
下図のようにできるだけ垂直に引き抜いて下さい。

(2) In case of unmating directly by hand
Please catch the catching area of plug and please pull plug to vertical direction as directly as possible.

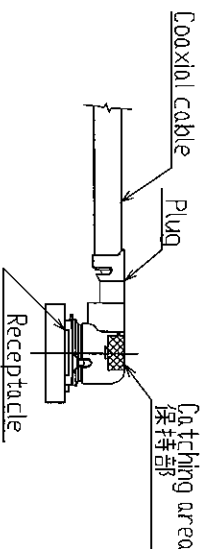

(2) 手で直接引き抜く場合
下図の保持部をつかみ、できるだけ垂直に引き抜いて下さい。



GENERAL TOLERANCE	
5 MAX.	±0.2
6 OVER MAX.	±0.3
30 OVER MAX.	±0.5
ANGLE	±2°

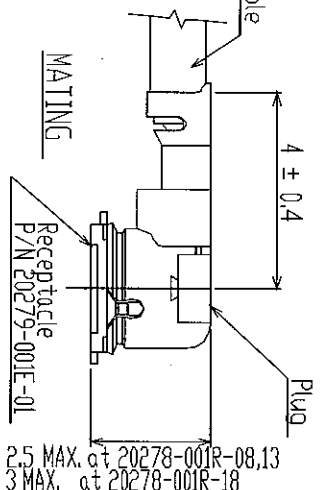

DESIGN'D BY	DATE	CHK'D BY	DATE
APP'D BY	DATE	APP'D BY	DATE
CUSTOMER COPY	PROJECTION	SCALE	UNIT
2814		-/4TH	mm
TITLE		DIVG. No.	
I-PEX Interconnect and Packaging Electronics TOKYO, JAPAN		20278	
MHF series micro coaxial connector plug vertical		SHEET REV.	
		2/2 1	

PART NO.
20279-001R-01

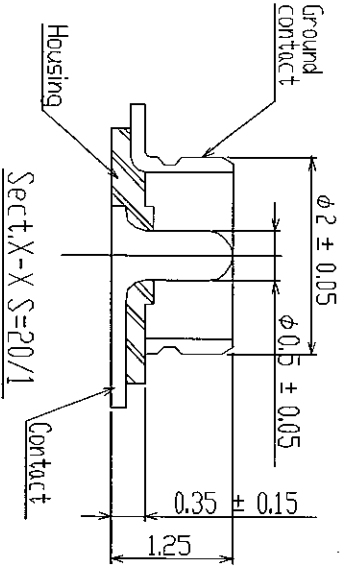
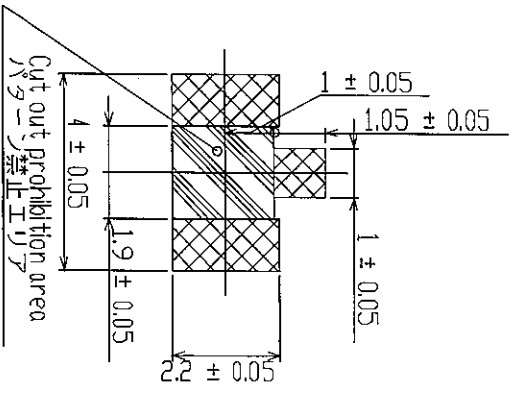
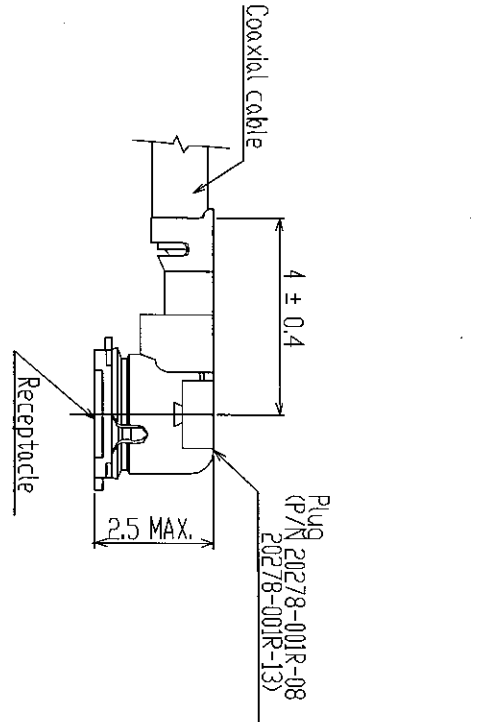
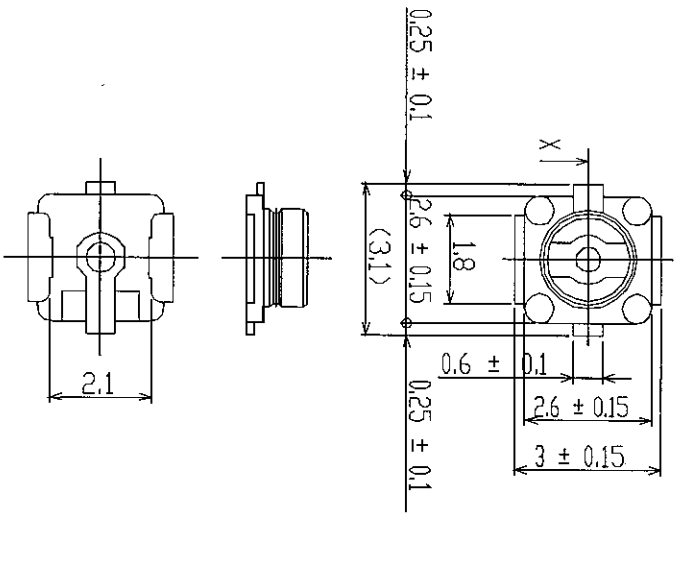

Notes

1. Material
 (1) Housing : LCP , UL 94V-0, white
 (2) Contact : brass , gold plating
 (3) Ground contact phosphor bronze , gold plating
2. Coplanarity : 0.1mm MAX.
3. Packing : emboss tape
4. Mating partner part No. : 20278-001R-xx

MATING

Notes

1. 材料
 (1) ハウジング: LCP, UL94V-0, 白色
 (2) コンタクト: 黄銅, 金メッキ
 (3) グラウンドコンタクト: リン青銅, 金メッキ
2. コプラナリティ: 0.1mm MAX.
3. 梱包 : インボスタレーナ
4. かん合相手 part No. : 20278-001R-xx

RECOMMENDED FOOTPRINT PATTERN

GENERAL TOLERANCE

6 MAX	±0.2
6 OVER MAX.30	±0.3
30 OVER MAX.120	±0.5
ANGLE	±2°

Reference

DESIGN BY K.Ohno	DATE JUN/07/01	DESIGN BY K.Ohno	DATE JUN/07/01
CHK'D BY E.Kurobe	DATE JUN/07/01	CHK'D BY E.Kurobe	DATE JUN/07/01
APP'D BY K.Kotobuchi	DATE JUN/07/01	APP'D BY K.Kotobuchi	DATE JUN/07/01
REVISION REV. 0	BY DATE	REVISION REV. 0	BY DATE
SERIES NO. 2814	CUSTOMER COPY	SERIES NO. 2814	CUSTOMER COPY
TITLE MHF series micro coaxial connector receptacle vertical		TITLE MHF series micro coaxial connector receptacle vertical	
SCALE UNIT 10/1mm		SCALE UNIT 10/1mm	
DWG. No. 20279		DWG. No. 20279	
SHEET REV. 1/1		SHEET REV. 1/1	
0		0	

FORM REV.4

WAS T



Interconnect
and Packaging Electronics
TOKYO, JAPAN

PART NO.
950231-001

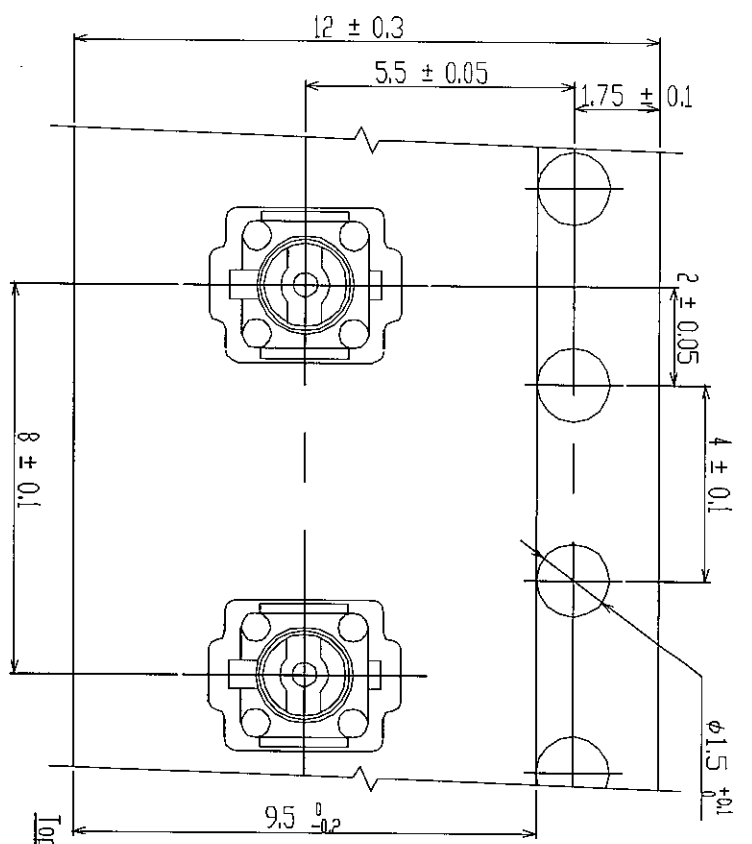

Feed direction

Emboss tape
S=10/1

Notes

1.0 quantity
2500pcs./reel

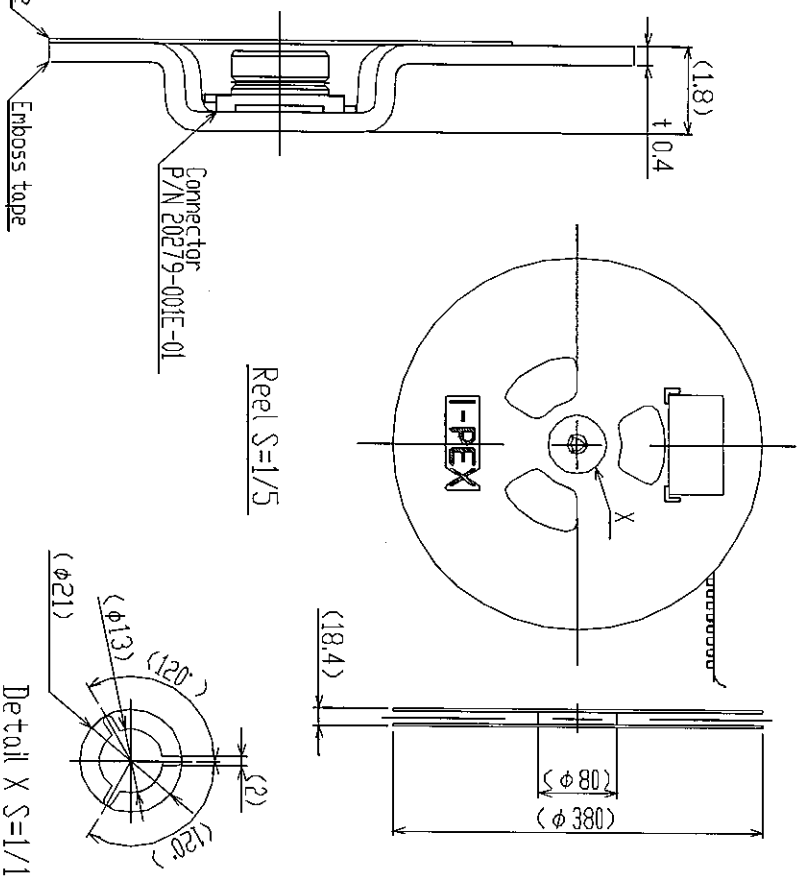
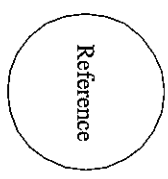

Reel S=1/5

Detail X S=1/1

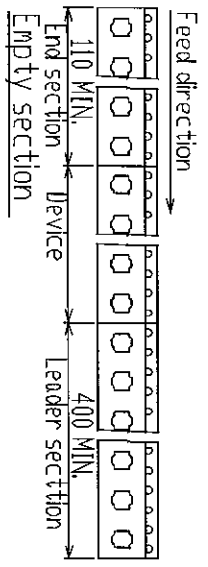

GENERAL TOLERANCE	
6 MAX.	±0.2
6 OVER MAX.30	±0.3
30 OVER MAX.120	±0.5
ANGLE	±2°

FORM REV.4

DESIGNED BY KOHNOYOSHI	DATE JUN/26/01	 Interconnect and Packaging Electronics TKY-VJ, JAPAN
CHK'D BY EKUNOBE	DATE JUN/29/01	
APP'D BY KATOKUCHI	DATE JUN/29/01	
REV/ECN BY REV/RECORD	DATE APP	
SERIES NO. P814	PROJECTION	
CUSTOMER COPY	SCALE UNIT 10/1mm	DWG. No. 950231
		SHEET REV. 1/1 0

VAS T