

AUX antenna -@5.25GHz

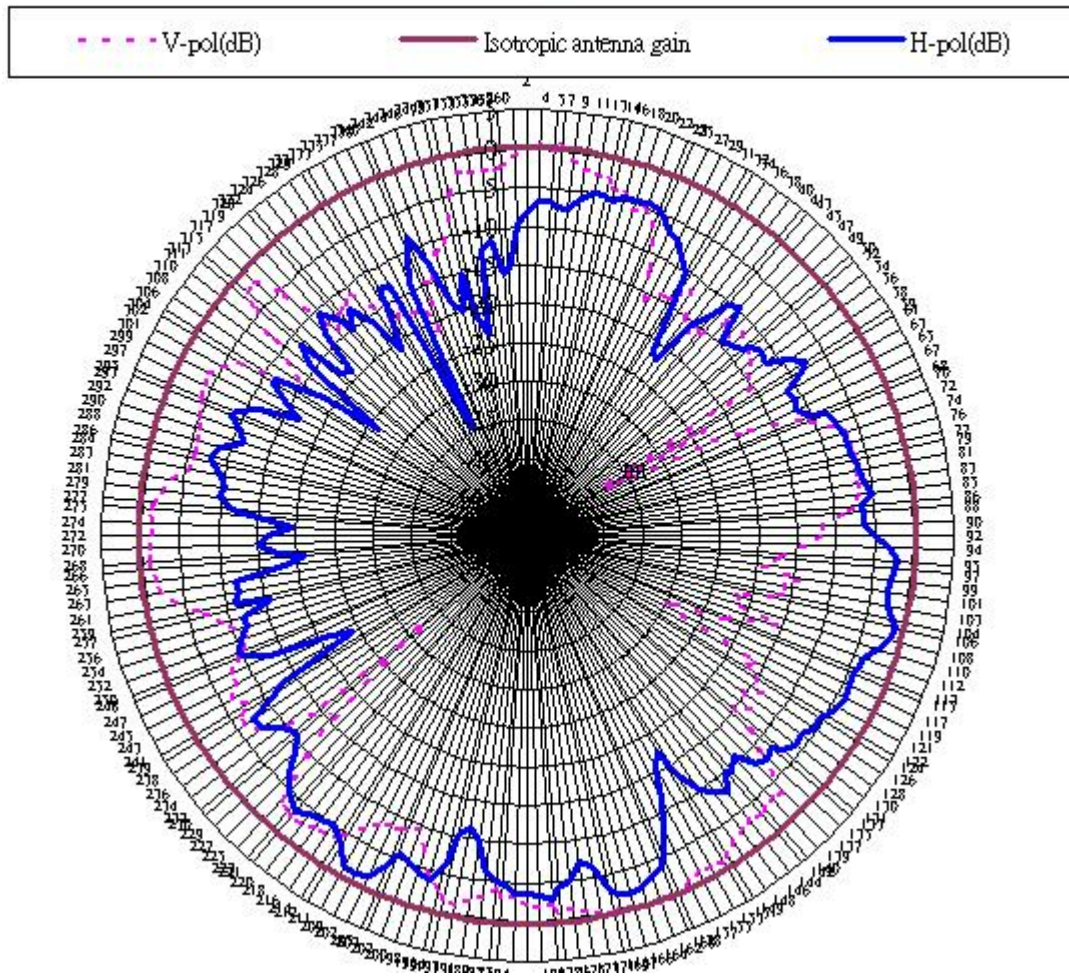

Center Frequency	5250 MHz
Horizontal (dBi) peak	-0.86
Vertical (dBi) peak	0.54
Horz+Vert (dBi) peak	2.12

AUX antenna -@5.35GHz

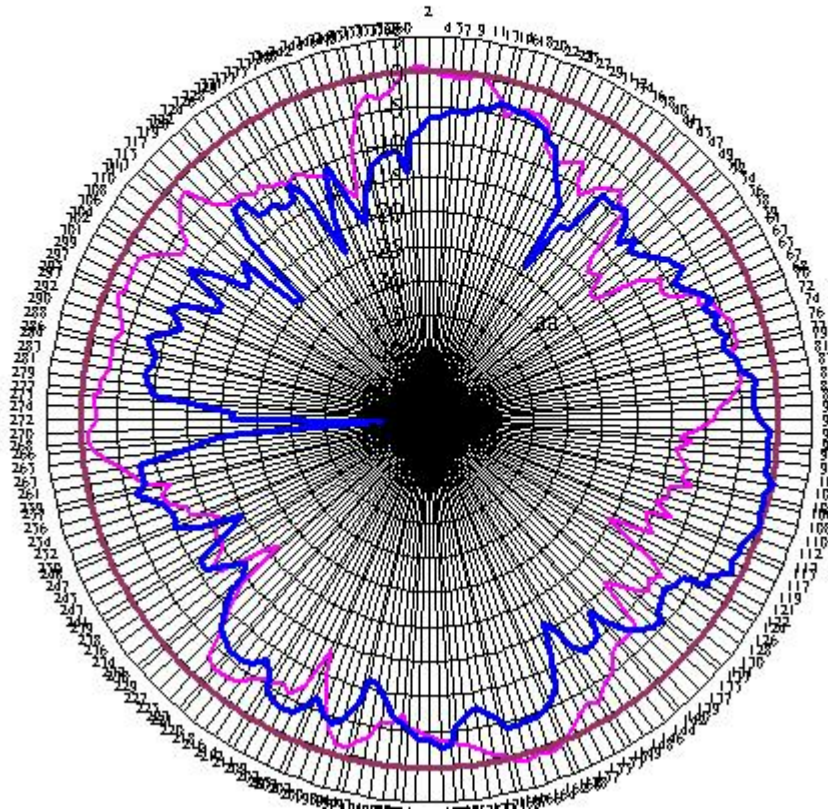
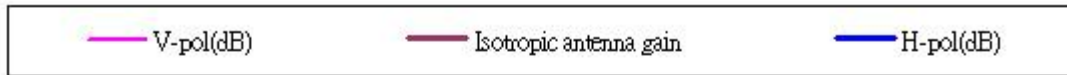

Center Frequency	5350 MHz
Horizontal (dBi) peak	0.48
Vertical (dBi) peak	1.13
Horz+Vert (dBi) peak	2.25

5470-5725MHz radiation characteristic

Main antenna -@5.47GHz

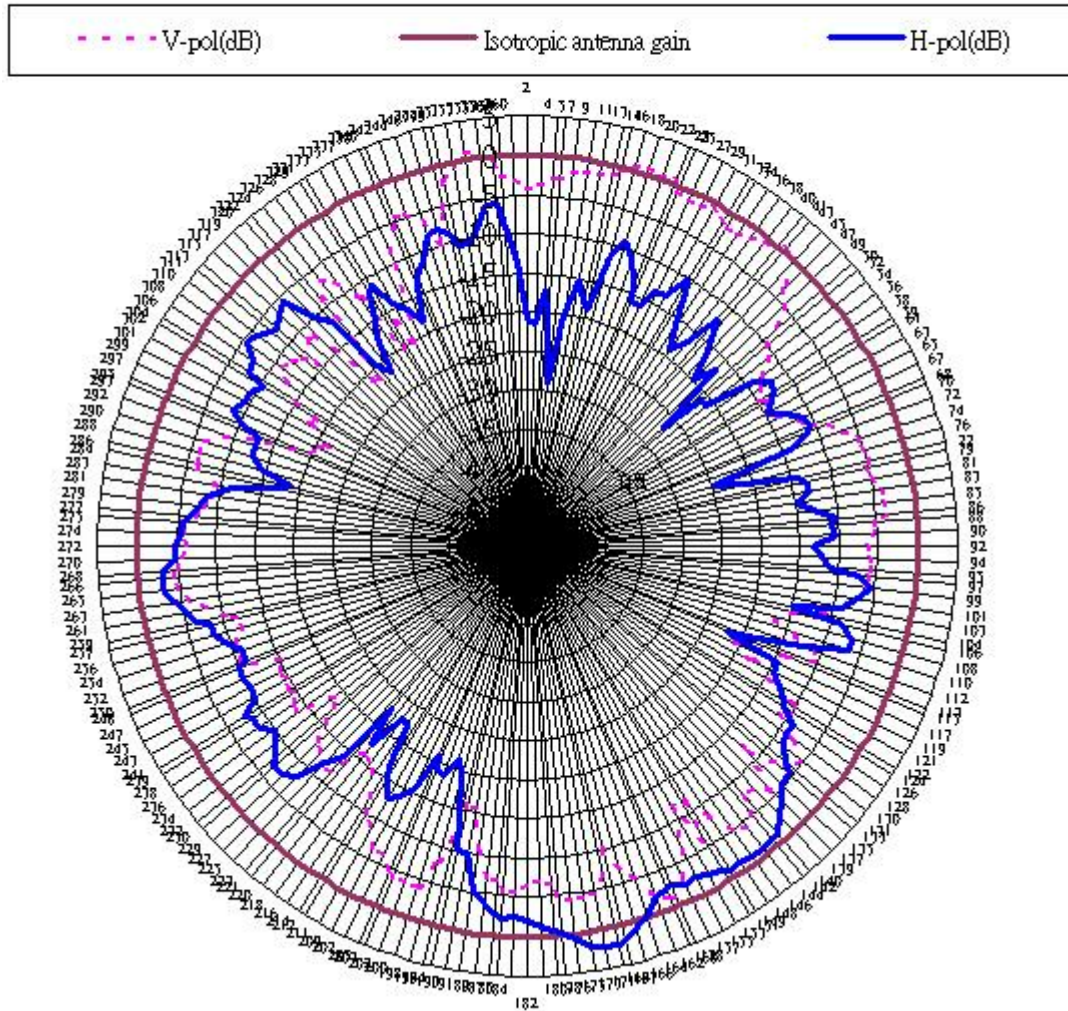

Center Frequency	5470 MHz
Horizontal (dBi) peak	2.1
Vertical (dBi) peak	0.91
Horz+Vert (dBi) peak	1.93

Main antenna -@5.6475GHz

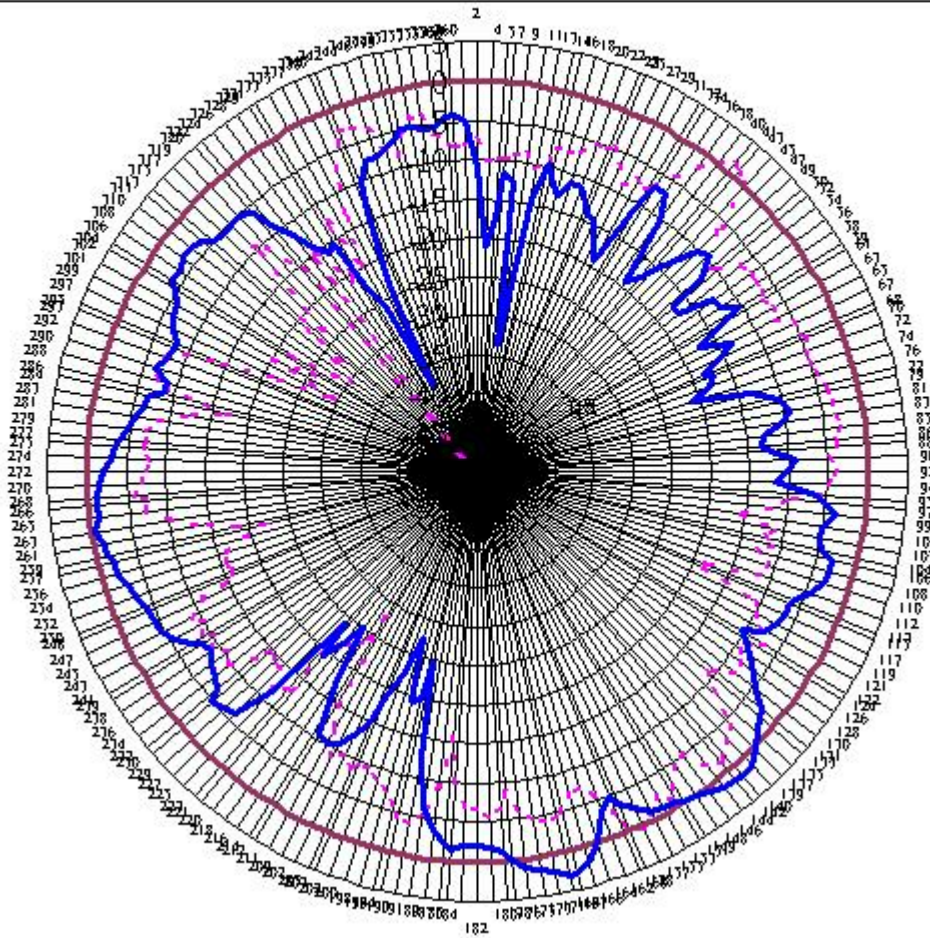
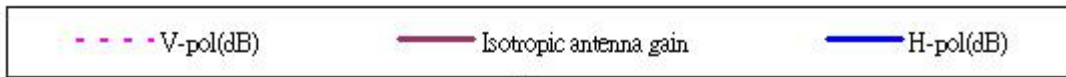

Center Frequency	5647.5 MHz
Horizontal (dBi) peak	3
Vertical (dBi) peak	1.07
Horz+Vert (dBi) peak	1.91

Main antenna -@5.825GHz

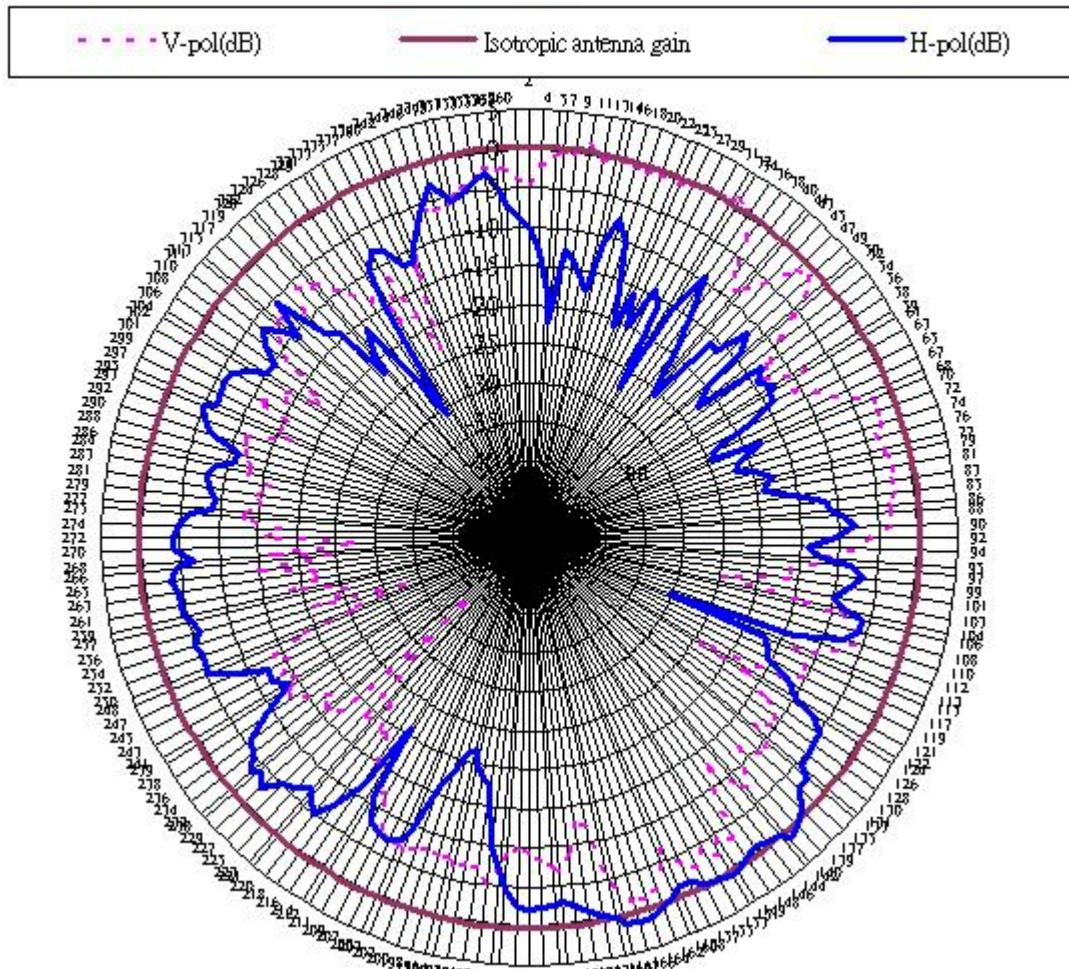

Center Frequency	5825 MHz
Horizontal (dBi) peak	0.84
Vertical (dBi) peak	-1.11
Horz+Vert (dBi) peak	1.73

AUX antenna -@5.47GHz

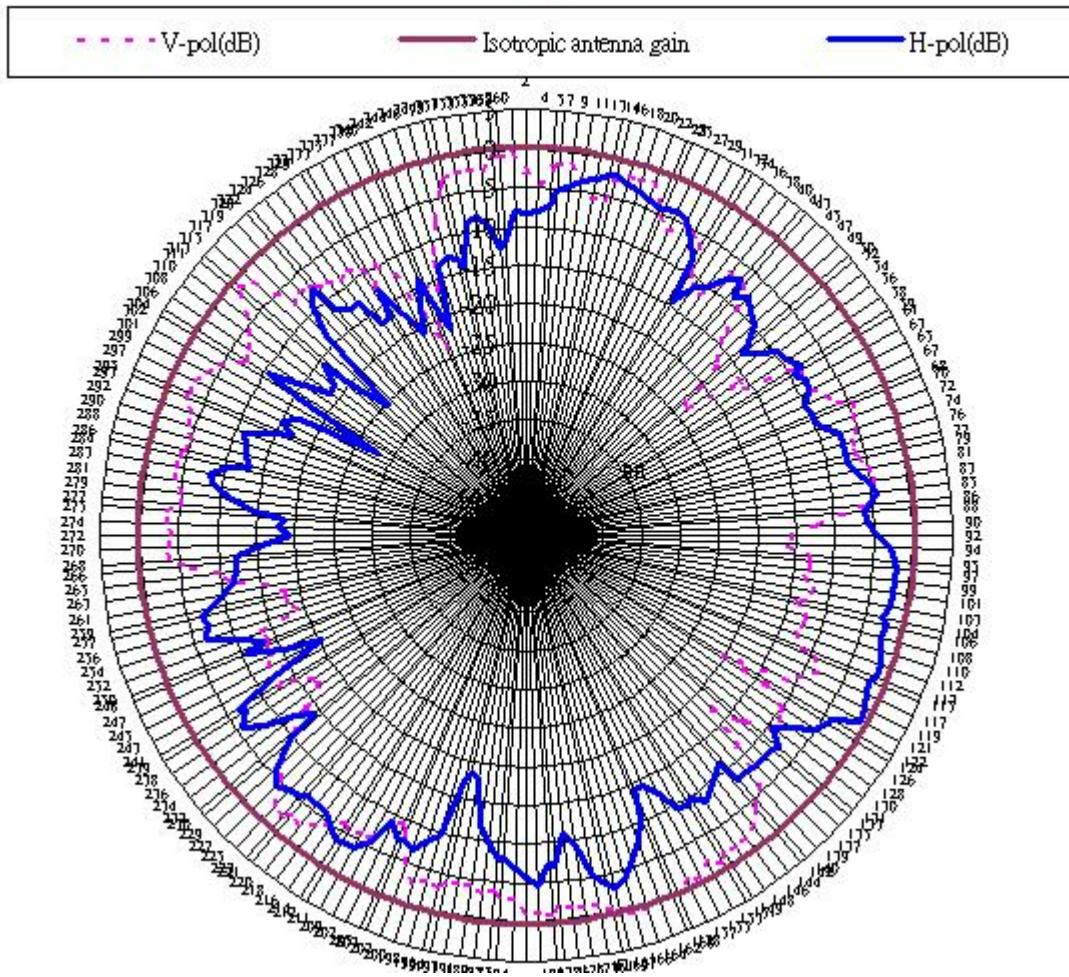

Center Frequency	5470 MHz
Horizontal (dBi) peak	-0.64
Vertical (dBi) peak	0.67
Horz+Vert (dBi) peak	2.01

AUX antenna -@5.6475GHz

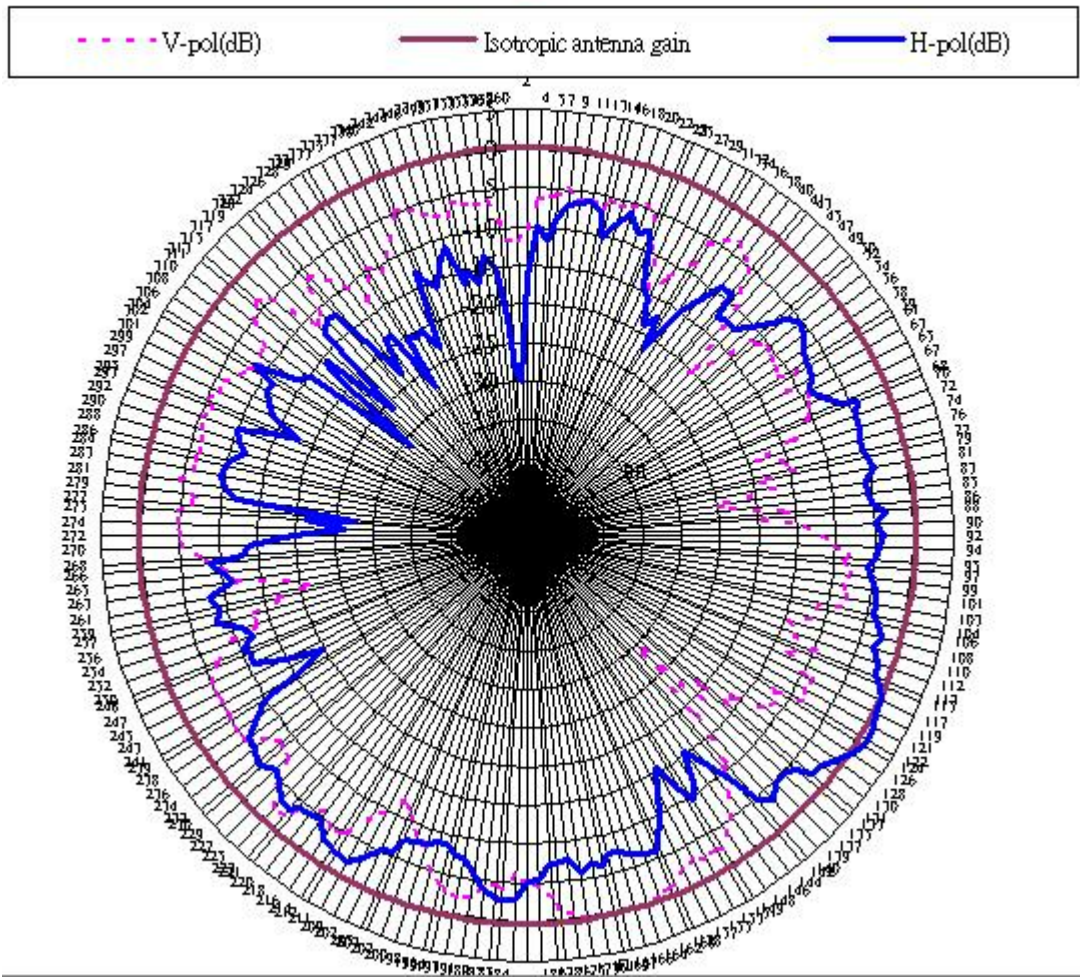

Center Frequency	5647.5MHz
Horizontal (dBi) peak	1.23
Vertical (dBi) peak	0.27
Horz+Vert (dBi) peak	1.51

AUX antenna -@5.825GHz

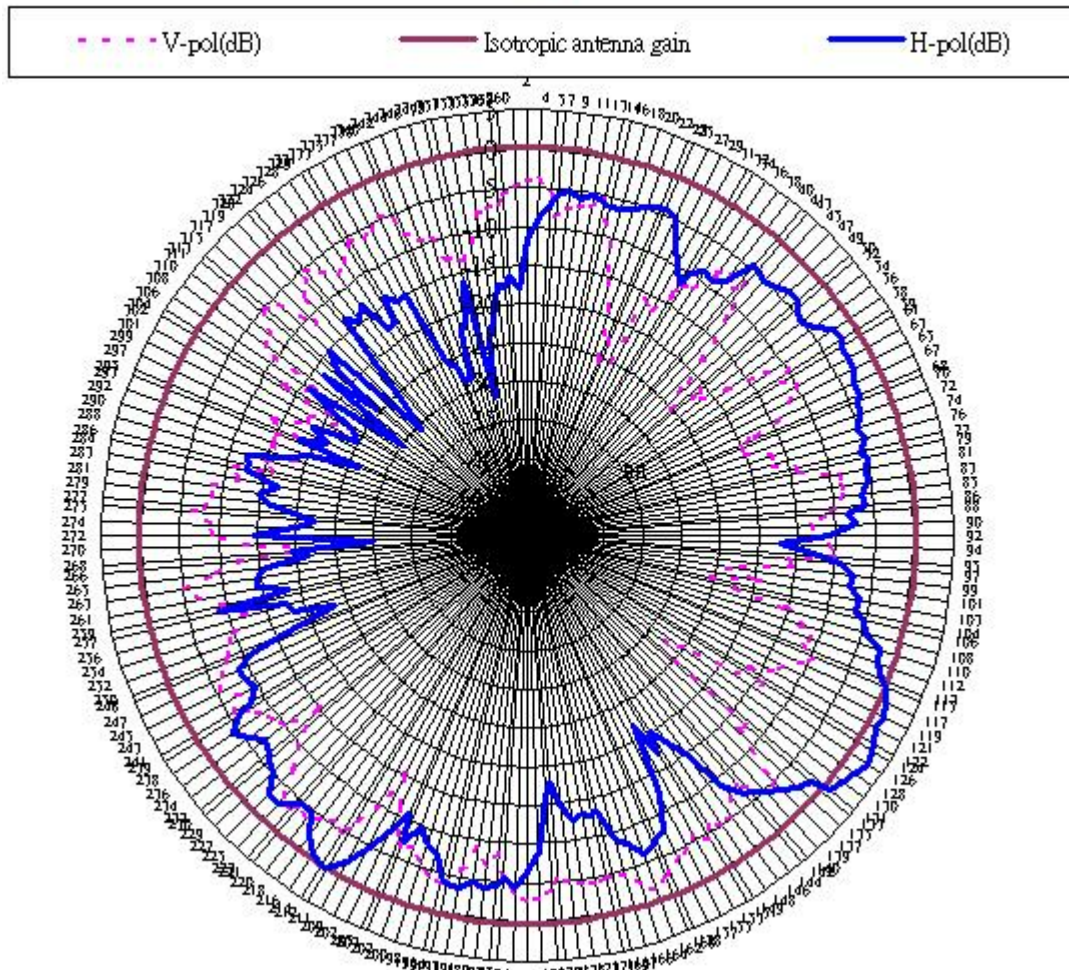

Center Frequency	5825 MHz
Horizontal (dBi) peak	2.95
Vertical (dBi) peak	-1.43
Horz+Vert (dBi) peak	2.88

Host PC Information

Host model:

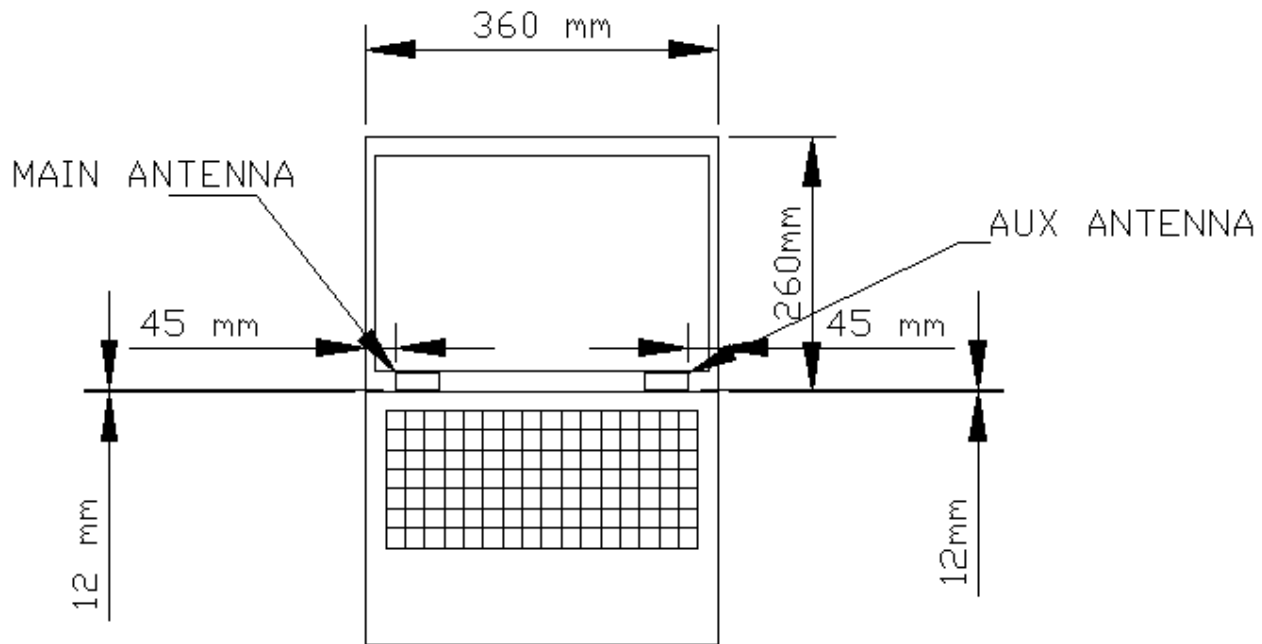

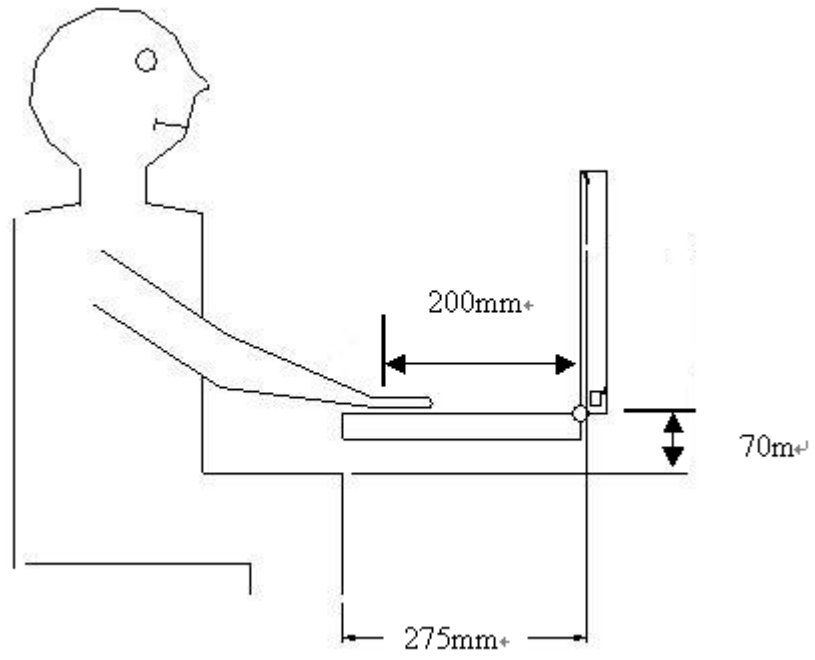
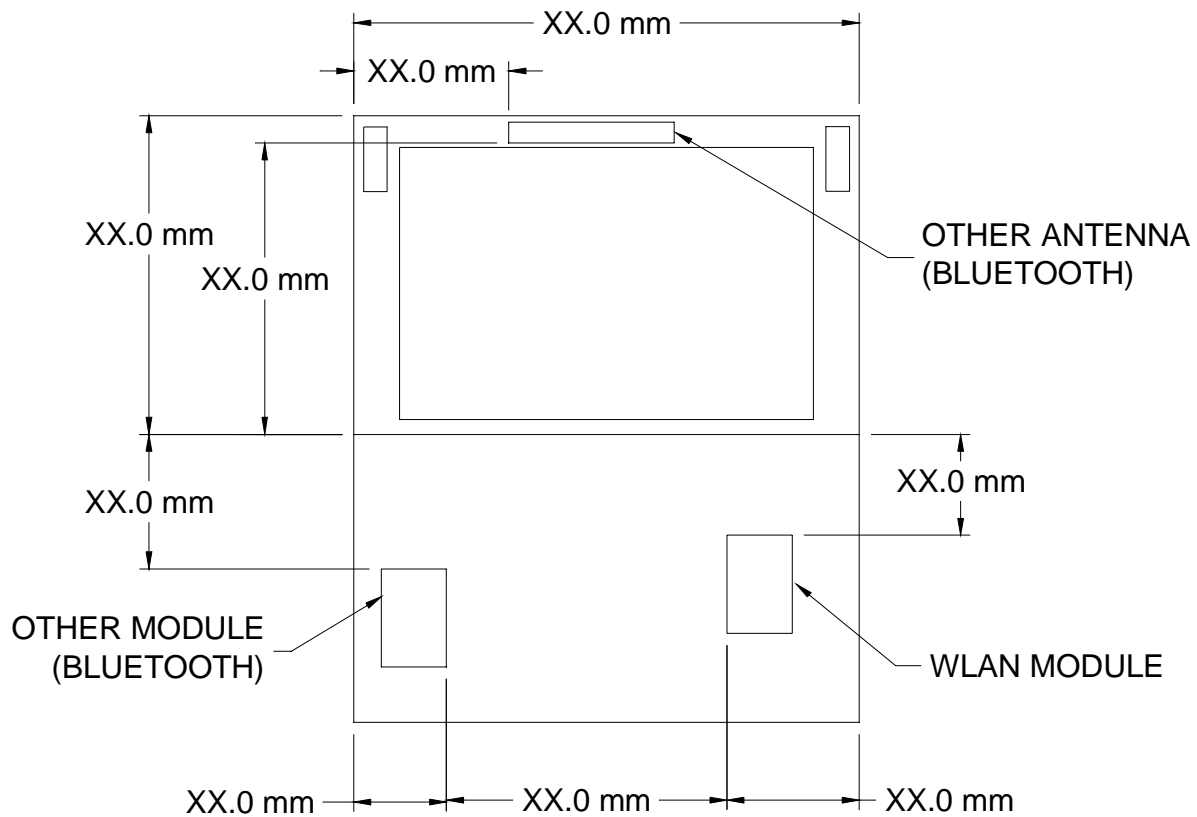
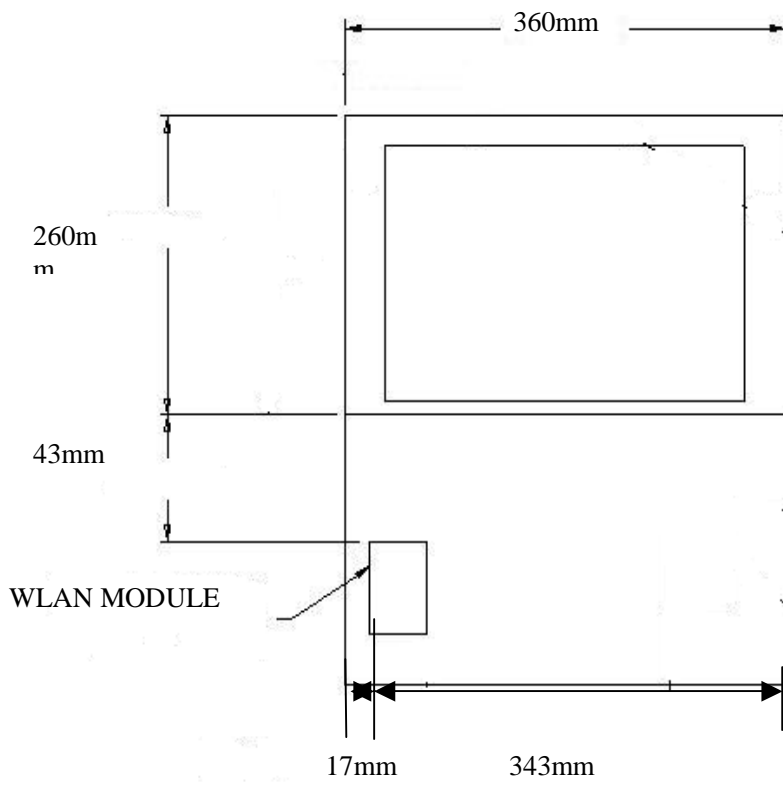

Diagram Example of Co-Location Antenna Separation

Should indicate distance between WLAN module antennas and Bluetooth antenna element.

(Note: Due to the evolving rules regarding co-location each platform and/or system will need to be reviewed on a case by case basis)





APPENDIX I

Intel's Antenna review process:

1. Regulatory Program Manager receives OEM antenna information.
2. Regulatory Program Manager will arrange an, Antenna information review. Provide feedback and request information not provided.
3. Then assign the OEMs a time line.
4. Check for the following below:
 - VSWR
 - Main & Aux antenna (Peak Gain W/ cable loss)
 - Main & Aux antenna (Peak Gain only)
 - Main & Aux antenna (Cable loss W/ connector)
 - Mechanical Drawings of Main & Aux. antenna
 - Radiation Characteristic of antenna Loaded (In a host system)
 - Max allowable input power
 - Manufacturer Name
 - Manufacturer Type

The information above is what this document is!

INTEL OEM / ODM, ANTENNA REGULATORY INFORMATION CHECKLIST

Description of Information Received	Received	Date
VSWR of cable including connector		
Main & Aux antenna (Peak Gain W/ cable loss)		
Main & Aux antenna (Peak Gain only)		
Main & Aux antenna (Cable loss W/ connector)		
Mechanical Drawings of Main & Aux. antenna		
Radiation Characteristic of antenna Loaded (In a host system)		
Max allowable input power		
Designator / Part number of antenna assembly		
Designator for Antenna only		
Manufacturer Name		
Manufacturer Type		