

**Radiated Emissions**



**X-Position**



**Y-Position**



**Z-Position**

**Audio low pass filter response measurement**

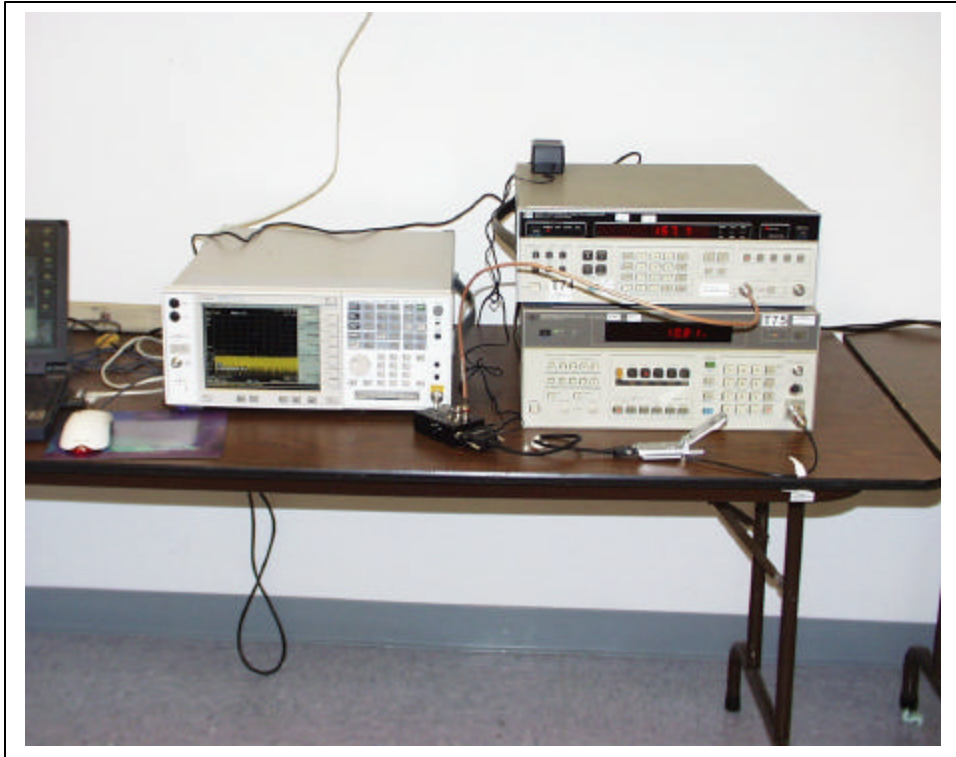

**MEASUREMENT INSTRUMENT**

EQUIPMENT	MANUFACTURE	MODEL NO.	SERIAL NO.	CAL. DUE DATE
Modulation Analyzer	HP	8901b	3438A05272	6/23/04
PSA Analyzer	Agilent	E446A	US42070220	1/13/04
Audio Signal Generator	HP	3325A	2652A24749	5/8/04
10dB Attenuator	Agilent	8493C	59028	N/A
DC Power Supply	Kenwood	PA36-3A	7060074	N/A

### 7.3. SECTION 2.1049: EMISSIONS MASK & OCCUPIED BANDWIDTH

#### PROVISIONS APPLICABLE

According to CFR 47 section 22.917.

#### TEST SETUP

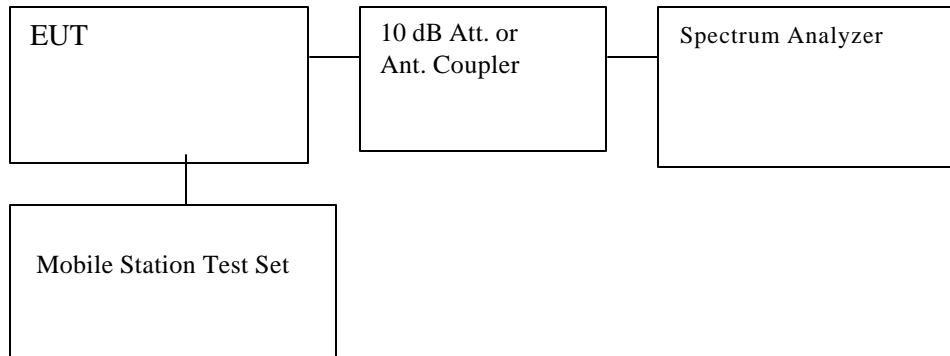

Set-up Configuration

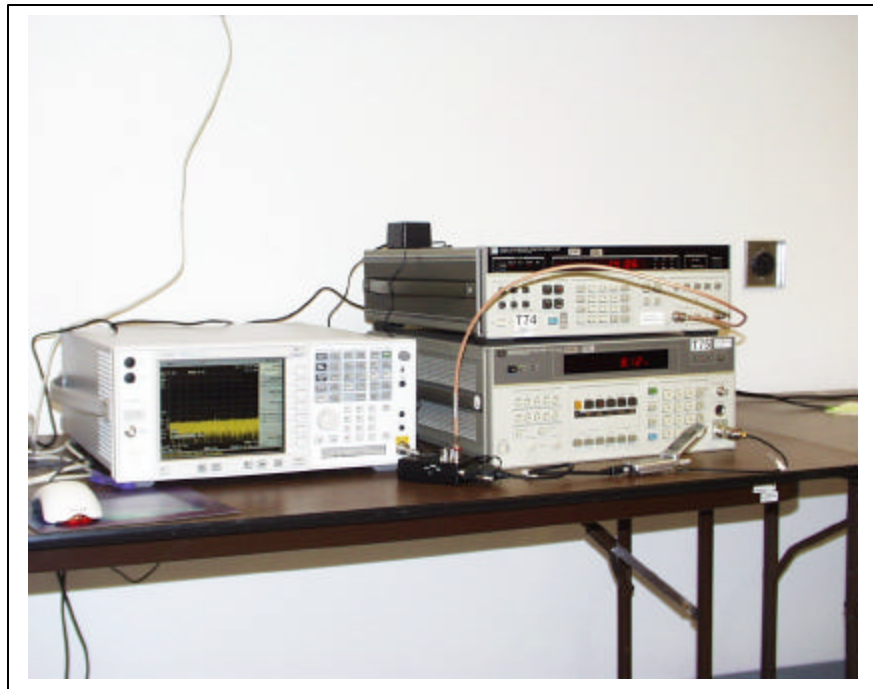

## **TEST PROCEDURE**

- **Frequency stability versus environmental temperature**

- 1). Setup the configuration per figure 6 for frequencies measurement inside the environmental chamber. Set the temperature of the chamber to 25°C. Set SA Resolution Bandwidth low enough to obtain the desired frequency resolution and measure the EUT 25°C operating frequency as reference frequency.
- 2). Turn EUT off and set Chamber temperature to -30°C.
- 3). Allow sufficient time (approximately 20 to 30 minus after chamber reach the assigned temperature) for EUT to stabilize. Turn on EUT and measure the EUT operating frequency. Turn off EUT after the measurement.
- 4). Repeat step 3 with a 10°C increased per stage until the highest temperature of +50°C reached, record all measured frequencies on each temperature step.

- **Frequency stability versus AC input voltage**

- 1). Setup the configuration per figure 6 and set chamber temperature to 25°C. Use a variable AC power supply to power the EUT and set AC output voltage to EUT nominal input AC voltage. Set SA Resolution Bandwidth low enough to obtain the desired frequency resolution and measure the EUT 25°C operating frequency as reference frequency.
- 2). Slowly reduce the EUT input voltage to specified extreme voltage variation ( $\pm 15\%$ ) and record the maximum frequency change.

## **MEASUREMENT RESULT**

*No non-compliance noted, as shown below.*

