



RF TEST REPORT

Applicant Compal Electronics, Inc.
FCC ID GKREXCN1
Product 4G LCC Module
Brand COMPAL
Model EXC-N1
Report No. R2209A0845-R5V2
Issue Date October 20, 2022

TA Technology (Shanghai) Co., Ltd. tested the above equipment in accordance with the requirements in **FCC CFR47 Part 2 (2021)/ FCC CFR47 Part 27C (2021)**. The test results show that the equipment tested is capable of demonstrating compliance with the requirements as documented in this report.

Prepared by: Xu Ying

Approved by: Xu Kai

TA Technology (Shanghai) Co., Ltd.

Building 3, No.145, Jintang Rd, Tangzhen Industry Park, Pudong Shanghai, China

TEL: +86-021-50791141/2/3

FAX: +86-021-50791141/2/3-8000



TABLE OF CONTENT

1	Test Laboratory	5
1.1	Notes of the Test Report	5
1.2.	Test facility	5
1.3	Testing Location	5
2	General Description of Equipment under Test	6
2.1	Applicant and Manufacturer Information	6
2.2	General information	6
3	Applied Standards	7
4	Test Configuration	8
5	Test Case	9
5.1	RF Power Output and Effective Isotropic Radiated Power	9
5.2	Occupied Bandwidth	11
5.3	Band Edge	12
5.4	Peak-to-Average Power Ratio (PAPR)	14
5.5	Frequency Stability	15
5.6	Spurious Emissions at Antenna Terminals	16
5.7	Radiates Spurious Emission	18
6	Test Results	21
6.1	RF Power Output and Effective Isotropic Radiated Power	21
6.2	Occupied Bandwidth	31
6.3	Band Edge	43
6.4	Peak-to-Average Power Ratio (PAPR)	57
6.5	Frequency Stability	59
6.6	Spurious Emissions at Antenna Terminals	65
6.7	Radiates Spurious Emission	70
7	Main Test Instruments	73
	ANNEX A: The EUT Appearance and Change declaration letter	74
	ANNEX B: Test Setup Photos	75



Version	Revision description	Issue Date
Rev.0	Initial issue of report.	September 28, 2022
Rev.1	Update information.	October 19, 2022
Rev.2	Update description.	October 20, 2022

Note: This revised report (Report No. R2209A0845-R5V2) supersedes and replaces the previously issued report (Report No. R2209A0845-R5V1). Please discard or destroy the previously issued report and dispose of it accordingly.



Summary of Measurement Results

Number	Test Case	Clause in FCC rules	Verdict
1	RF Power Output and Effective Isotropic Radiated Power	2.1046 27.50(d)(4) 27.50(h)(2)	PASS
2	Occupied Bandwidth	2.1049	PASS
3	Band Edge	27.53(h) 27.53(m)	PASS
4	Peak-to-Average Power Ratio	27.50(d)/KDB971168 D01(5.7)	PASS
5	Frequency Stability	2.1055 / 27.54	PASS
6	Spurious Emissions at Antenna Terminals	2.1051 27.53(h) 27.53(m)	PASS
7	Radiates Spurious Emission	2.1053 27.53(h) 27.53(m)	PASS

Date of Testing: August 26, 2022~ August 29, 2022

Date of Sample Received: August 25, 2022

Note: 1. PASS: The EUT complies with the essential requirements in the standard.

FAIL: The EUT does not comply with the essential requirements in the standard.

All indications of Pass/Fail in this report are opinions expressed by TA Technology (Shanghai) Co., Ltd. based on interpretations and/or observations of test results. Measurement Uncertainties were not taken into account and are published for informational purposes only.

2. All test values duplicated from the report (Report No.: R2208A0783-R5).



1 Test Laboratory

1.1 Notes of the Test Report

This report shall not be reproduced in full or partial, without the written approval of **TA technology (shanghai) co., Ltd.** The results documented in this report apply only to the tested sample, under the conditions and modes of operation as described herein .Measurement Uncertainties were not taken into account and are published for informational purposes only. This report is written to support regulatory compliance of the applicable standards stated above.

1.2. Test facility

FCC (Designation number: CN1179, Test Firm Registration Number: 446626)

TA Technology (Shanghai) Co., Ltd. has been listed on the US Federal Communications Commission list of test facilities recognized to perform measurements.

A2LA (Certificate Number: 3857.01)

TA Technology (Shanghai) Co., Ltd. has been listed by American Association for Laboratory Accreditation to perform measurement.

1.3 Testing Location

Company: TA Technology (Shanghai) Co., Ltd.
Address: Building 3, No.145, Jintang Rd, Tangzhen Industry Park, Pudong Shanghai, China
City: Shanghai
Post code: 201201
Country: P. R. China
Contact: Xu Kai
Telephone: +86-021-50791141/2/3
Fax: +86-021-50791141/2/3-8000
Website: <http://www.ta-shanghai.com>
E-mail: xukai@ta-shanghai.com

2 General Description of Equipment under Test

2.1 Applicant and Manufacturer Information

Applicant	Compal Electronics, Inc.
Applicant address	No.581 & 581-1, Ruiguang Rd., Neihu District, Taipei, (114) Taiwan
Manufacturer	Compal Electronics, Inc.
Manufacturer address	No.581 & 581-1, Ruiguang Rd., Neihu District, Taipei, (114) Taiwan

2.2 General information

EUT Description			
Model	EXC-N1		
IMEI	864086063401826		
Hardware Version	EXC-N1_MB_V1.01		
Software Version	EXC-N1_4.71.5_EQ101		
Power Supply	External power supply		
Antenna Type	The EUT don't have standard Antenna. The Antenna used for testing in this report is the after-market accessory.		
Antenna Gain	LTE Band 7: 3.9dBi LTE Band 66: 2.5dBi		
Test Mode(s)	LTE Band 7/66		
Test Modulation	(LTE)QPSK, 16QAM;		
LTE Category	4		
Maximum E.I.R.P./ E.R.P.	LTE Band 7:	26.24 dBm	
	LTE Band 66:	27.45 dBm	
Rated Power Supply Voltage	3.8V		
Operating Voltage	Minimum: 3.3V Maximum: 4.2V		
Operating Temperature	Lowest: -40°C Highest: +85°C		
Testing Temperature	Lowest: -40°C Highest: + 90°C		
Operating Frequency Range(s)	Mode	Tx (MHz)	Rx (MHz)
	LTE Band 7	2500 ~ 2570	2620 ~ 2690
	LTE Band 66	1710 ~ 1780	2110 ~ 2200
Note: 1. The EUT is sent from the applicant to TA and the information of the EUT is declared by the applicant.			



3 Applied Standards

According to the specifications of the manufacturer, it must comply with the requirements of the following standards:

Test standards:

FCC CFR47 Part 27C (2021)

FCC CFR47 Part 2 (2021)

Reference standard:

ANSI C63.26-2015

KDB 971168 D01 Power Meas License Digital Systems v03r01

4 Test Configuration

Radiated measurements are performed by rotating the EUT in three different orthogonal test planes. EUT stand-up position (Z axis), lie-down position (X, Y axis). Receiver antenna polarization (horizontal and vertical), the worst emission was found in position (Z axis, vertical polarization) and the worst case was recorded.

All mode and data rates and positions and RB size and modulations were investigated.

Subsequently, only the worst case emissions are reported.

The following testing in LTE is set based on the maximum RF Output Power.

The following testing in different Bandwidth is set to detail in the following table:

Test modes are chosen to be reported as the worst case configuration below:

Test modes are chosen to be reported as the worst case configuration below for LTE Band 7/66:

Test items	Modes	Bandwidth (MHz)						Modulation		RB			Test Channel			
		1.4	3	5	10	15	20	QPSK	16QAM	1	50%	100%	L	M	H	
RF Power Output and Effective Isotropic Radiated Power	LTE 7	-	-	0	0	0	0	0	0	0	0	0	0	0	0	0
	LTE 66	0	0	0	0	0	0	0	0	0	0	0	0	0	0	0
Occupied Bandwidth	LTE 7	-	-	0	0	0	0	0	0	-	-	0	0	0	0	0
	LTE 66	0	0	0	0	0	0	0	0	-	-	0	0	0	0	0
Band Edge	LTE 7	-	-	0	0	0	0	0	0	0	-	0	0	-	0	0
	LTE 66	0	0	0	0	0	0	0	0	0	-	0	0	-	0	0
Peak-to-Average Power Ratio	LTE 7	-	-	0	0	0	0	0	0	-	-	0	0	0	0	0
	LTE 66	0	0	0	0	0	0	0	0	-	-	0	0	0	0	0
Frequency Stability	LTE 7	-	-	0	0	0	0	0	0	0	-	-	-	0	-	-
	LTE 66	0	0	0	0	0	0	0	0	0	-	-	-	0	-	-
Spurious Emissions at Antenna Terminals	LTE 7	-	-	0	0	0	0	0	-	0	-	-	0	0	0	0
	LTE 66	0	0	0	0	0	0	0	-	0	-	-	0	0	0	0
Radiates Spurious Emission	LTE 7	-	-	0	-	-	0	0	-	0	-	-	-	0	-	-
	LTE 66	0	-	0	-	-	0	0	-	0	-	-	-	0	-	-
Note	1. The mark "O" means that this configuration is chosen for testing. 2. The mark "-" means that this configuration is not testing.															

5 Test Case

5.1 RF Power Output and Effective Isotropic Radiated Power

Ambient condition

Temperature	Relative humidity	Pressure
23°C ~25°C	45%~50%	101.5kPa

Methods of Measurement

During the process of the testing, The EUT was connected to the Base Station Simulator with a known loss. The EUT is controlled by the Base Station Simulator test set to ensure max power transmission with proper modulation.

ERP can then be calculated as follows:

$$\text{EIRP (dBm)} = \text{Output Power (dBm)} - \text{Losses (dB)} + \text{Antenna Gain (dBi)}$$

where:dBd refers to gain relative to an ideal dipole.

$$\text{EIRP (dBm)} = \text{ERP (dBm)} + 2.15 \text{ (dB.)}$$

Test Setup

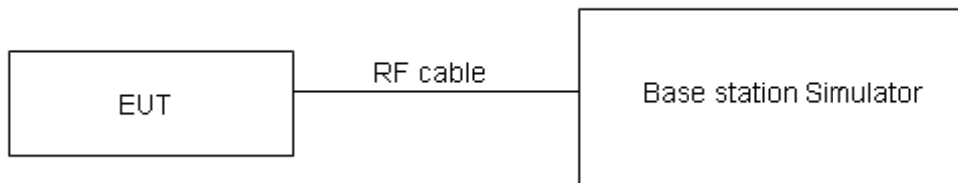

Limits

No specific RF power output requirements in part 2.1046.

Rule Part 27.50(d) (4) specifies that “Fixed, mobile and portable (hand-held) stations operating in the 1710–1755 MHz band are limited to 1 watt EIRP”

Rule Part 27.50(h) (2) specifies that “Mobile and other user stations. Mobile stations are limited to 2.0 watts EIRP. All user stations are limited to 2.0 watts transmitter output power.”

Part 27.50(d)(4)Limit	≤ 1 W (30 dBm)
Part 27.50(h)(2) Limit	≤ 2 W (33 dBm)



Measurement Uncertainty

The assessed measurement uncertainty to ensure 95% confidence level for the normal distribution is with the coverage factor $k = 2$, $U=0.4$ dB for RF power output, $k = 2$, $U= 1.19$ dB for ERP/EIRP.

Test Results

Refer to the section 6.1 of this report for test data.

5.2 Occupied Bandwidth

Ambient condition

Temperature	Relative humidity	Pressure
23°C ~25°C	45%~50%	101.5kPa

Method of Measurement

The EUT was connected to Spectrum Analyzer and Base Station Simulator via power Splitter. The occupied bandwidth is measured using spectrum analyzer.

RBW is set to $\geq 1\%EBW$, VBW is set to 3x RBW.

99% power and -26dBc occupied bandwidths are recorded. Spectrum analyzer plots are included on the following pages.

Test Setup

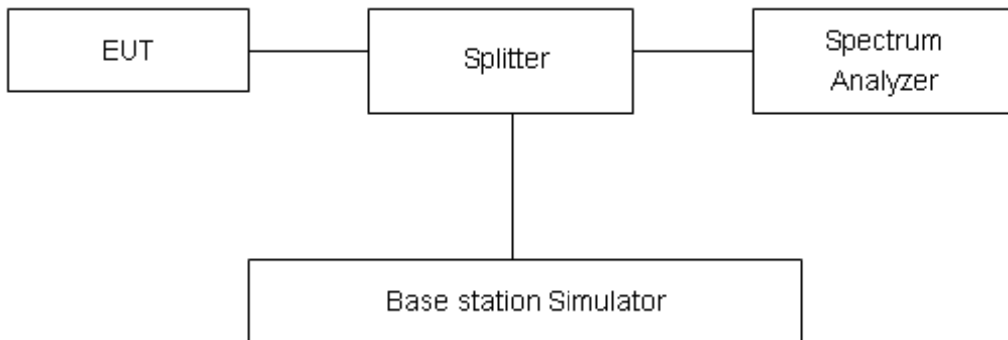

Limits

No specific occupied bandwidth requirements in part 2.1049.

Measurement Uncertainty

The assessed measurement uncertainty to ensure 95% confidence level for the normal distribution is with the coverage factor $k = 2$, $U=624\text{Hz}$.

Test Results

Refer to the section 6.2 of this report for test data.

5.3 Band Edge

Ambient condition

Temperature	Relative humidity	Pressure
23°C ~25°C	45%~50%	101.5kPa

Method of Measurement

The EUT was connected to Spectrum Analyzer and Base Station Simulator via power Splitter. The band edge of the lowest and highest channels were measured.

The testing follows KDB 971168 D01 v03r01 Section 6.0

The EUT was connected to spectrum analyzer and system simulator via a power divider.

The band edges of low and high channels for the highest RF powers were measured.

For LTE Band 7 set RBW \geq 1% EBW in the 1MHz band immediately outside and adjacent to the band edge. Beyond the 1 MHz band from the band edge, RBW=1MHz was used.

RBW is set to \geq 1%EBW, VBW is set to 3x RBW on spectrum analyzer.

Set spectrum analyzer with RMS detector.

The RF fundamental frequency should be excluded against the limit line in the operating frequency band.

Checked that all the results comply with the emission limit line.

Test Setup

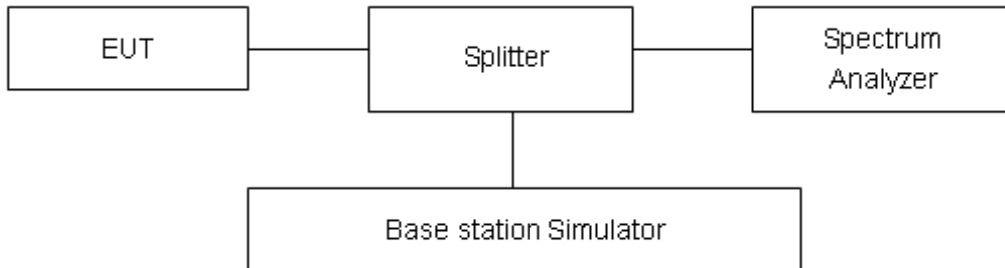

Limits

Rule Part 27.53(h) specifies that “ for operations in the 1695-1710 MHz, 1710-1755 MHz, 1755-1780 MHz, 1915-1920 MHz, 1995-2000 MHz, 2000-2020 MHz, 2110-2155 MHz, 2155-2180 MHz, and 2180-2200 bands, the power of any emission outside a licensee's frequency block shall be attenuated below the transmitter power (P) in watts by at least $43 + 10 \log_{10} (P)$ dB”

Rule Part 27.53(m) (4) specifies that “for BRS and EBS stations. For mobile digital stations, the attenuation factor shall be not less than $40 + 10 \log (P)$ dB on all frequencies between the channel edge and 5 megahertz from the channel edge, $43 + 10 \log (P)$ dB on all frequencies between 5 megahertz and X megahertz from the channel edge, and $55 + 10 \log (P)$ dB on all frequencies more than X megahertz from the channel edge, where X is the greater of 6 megahertz or the actual emission bandwidth as defined in paragraph (m)(4) of this section. In addition, the attenuation factor shall not be less that $43 + 10 \log (P)$ dB on all frequencies between 2490.5 MHz and 2496 MHz and



55 + 10 log (P) dB at or below 2490.5 MHz. Mobile Satellite Service licensees operating on frequencies below 2495 MHz may also submit a documented interference complaint against BRS licensees operating on channel BRS Channel 1 on the same terms and conditions as adjacent channel BRS or EBS licensees.

Example:

The limit line is derived from 43 + 10log (P) dB below the transmitter power P(Watts)
= P(W)- [43 + 10log(P)] (dB)
= [30 + 10log (P)] (dBm) - [43 + 10log(P)] (dB) = -13dBm.

Measurement Uncertainty

The assessed measurement uncertainty to ensure 95% confidence level for the normal distribution is with the coverage factor $k = 1.96$, $U=0.684$ dB.

Test Results

Refer to the section 6.3 of this report for test data.

5.4 Peak-to-Average Power Ratio (PAPR)

Ambient condition

Temperature	Relative humidity	Pressure
23°C ~25°C	45%~50%	101.5kPa

Methods of Measurement

Measure the total peak power and record as PPK. And measure the total average power and record as PAvg. Both the peak and average power levels must be expressed in the same logarithmic units (e.g., dBm). Determine the PAPR from:

$$PAPR (dB) = PPK (dBm) - PAvg (dBm).$$

Test Setup

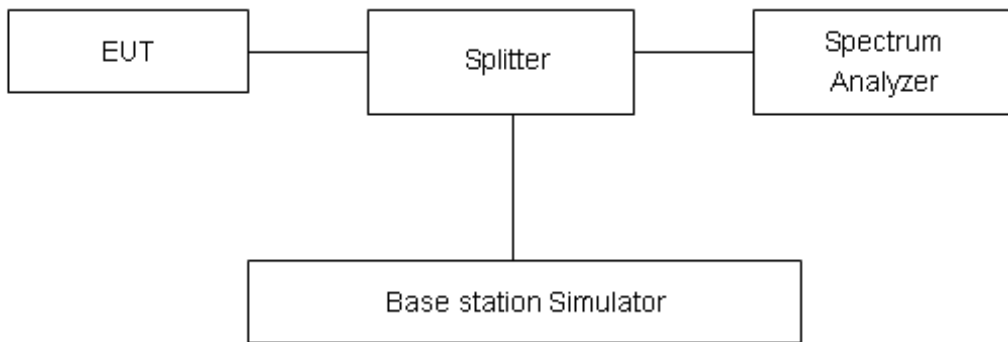

Limits

Rule Part 27.50(d)(5) Equipment employed must be authorized in accordance with the provisions of 24.51. Power measurements for transmissions by stations authorized under this section may be made either in accordance with a Commission-approved average power technique or in compliance with paragraph (d)(6) of this section. In measuring transmissions in this band using an average power technique, the peak-to-average ratio (PAR) of the transmission may not exceed 13 dB.

Measurement Uncertainty

The assessed measurement uncertainty to ensure 95% confidence level for the normal distribution is with the coverage factor $k = 2$, $U = 0.4$ dB.

Test Results

Refer to the section 6.4 of this report for test data.

5.5 Frequency Stability

Ambient condition

Temperature	Relative humidity	Pressure
23°C ~25°C	45%~50%	101.5kPa

Method of Measurement

Frequency Stability (Temperature Variation)

The temperature inside the climate chamber is varied from -40°C to +85°C in 10°C step size.

(1)With all power removed, the temperature was decreased to -10°C and permitted to stabilize for three hours.

(2)Measure the carrier frequency with the test equipment in a “call mode”. These measurements should be made within 1 minute of powering up the mobile station, to prevent significant self warming.

(3) Repeat the above measurements at 10°C increments from -40°C to +85°C. Allow at least 1.5 hours at each temperature, un-powered, before making measurements.

Frequency Stability (Voltage Variation)

The frequency stability shall be measured with variation of primary supply voltage as follows:

Primary Supply Voltage: The primary supply voltage is varied from 85% to 115% of the nominal value for non hand-carried battery and AC powered equipment. For hand-carried, battery-powered equipment, primary supply voltage is reduced to the battery operating end point which shall be specified by the manufacturer.

This transceiver is specified to operate with an input voltage of between 3.3 V and 4.2 V, with a nominal voltage of 3.8V.

Test setup

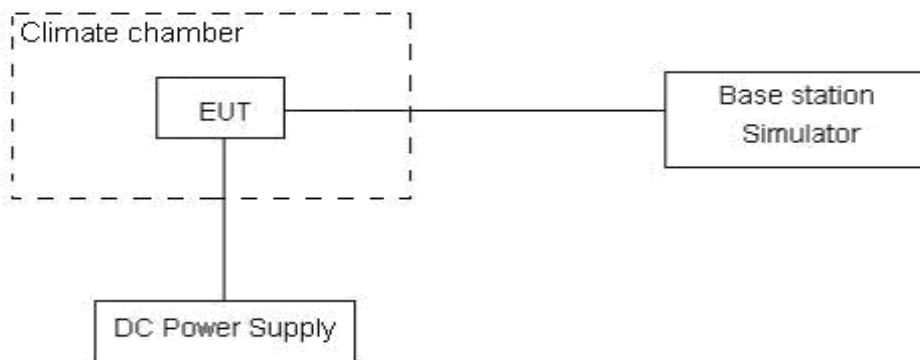

Limits

The frequency stability shall be sufficient to ensure that the fundamental emissions stay within the authorized bands of operation.

Measurement Uncertainty

The assessed measurement uncertainty to ensure 99.75% confidence level for the normal distribution is with the coverage factor $k = 3, U=0.01\text{ppm}$.

Test Results

Refer to the section 6.5 of this report for test data.

5.6 Spurious Emissions at Antenna Terminals

Ambient condition

Temperature	Relative humidity	Pressure
23°C ~25°C	45%~50%	101.5kPa

Method of Measurement

The EUT was connected to Spectrum Analyzer and Base Station Simulator via power Splitter. The measurement is carried out using a spectrum analyzer. The spectrum analyzer scans from 9kHz to the 10th harmonic of the carrier. The peak detector is used.

RBW is set to 1 kHz (0.009MHz~ 0.15 MHz),

RBW is set to 10 kHz (0.15 MHz~ 30 MHz)

RBW is set to 100 kHz (30MHz~1000 MHz)

RBW is set to 1000 kHz (above 1000MHz) Sweep is set to ATUO.

Of those disturbances below (limit – 20 dB), the mark is not required for the EUT.

The modulation mode and RB allocation refer to section 5.1, using the maximum output power configuration.

Test setup

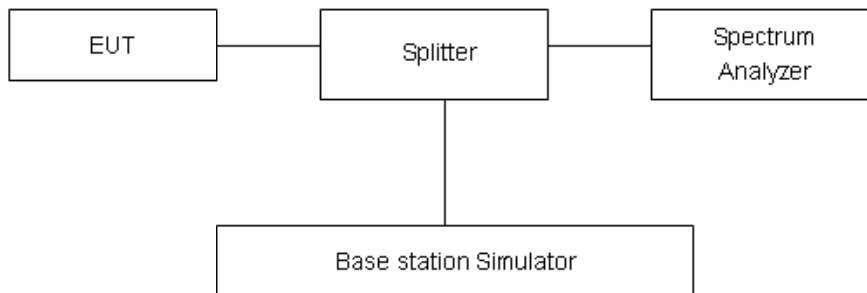

Limits

Rule Part 27.53(h) specifies that “for operations in the 1695-1710 MHz, 1710-1755 MHz, 1755-1780 MHz, 1915-1920 MHz, 1995-2000 MHz, 2000-2020 MHz, 2110-2155 MHz, 2155-2180 MHz, and 2180-2200 bands, the power of any emission outside a licensee's frequency block shall be attenuated below the transmitter power (P) in watts by at least $43 + 10 \log_{10}(P)$ dB..”

Rule Part 27.53(m) $55 + 10 \log(P)$ dB on all frequencies more than X megahertz from the channel edge, where X is the greater of 6 megahertz or the actual emission bandwidth as defined in paragraph (m)(4) of this section.

Part 27.53(h)/(g) Limit	-13 dBm
Part 27.53(m) Limit	-25 dBm



Measurement Uncertainty

The assessed measurement uncertainty to ensure 99.75% confidence level for the normal distribution is with the coverage factor $k = 1.96$.

Frequency	Uncertainty
9kHz-1GHz	0.684 dB
1GHz-26.5GHz	1.407 dB

Test Results

Refer to the section 6.6 of this report for test data.



5.7 Radiates Spurious Emission

Ambient condition

Temperature	Relative humidity	Pressure
23°C ~25°C	45%~50%	101.5kPa

Method of Measurement

1. The testing follows FCC KDB 971168 D01 v03r01 Section 5.8 and ANSI C63.26-2015.
2. Below 1GHz: The EUT is placed on a turntable 0.8 meters above the ground in the chamber, 3 meter away from the antenna. The maximal emission value is acquired by adjusting the antenna height, polarisation and turntable azimuth. Normally, the height range of antenna is 1 m to 4 m, the azimuth range of turntable is 0° to 360°, and the receive antenna has two polarizations Vertical (V) and Horizontal (H). Above 1GHz: (Note: the FCC's permission to use 1.5m as an alternative per TCBC Conf call of Dec. 2, 2014.) The EUT is placed on a turntable 1.5 meters above the ground in the chamber, 3 meter away from the antenna. The maximal emission value is acquired by adjusting the antenna height, polarisation and turntable azimuth. Normally, the height range of antenna is 1 m to 4 m, the azimuth range of turntable is 0° to 360°, and the receive antenna has two polarizations Vertical (V) and Horizontal (H).
3. A loop antenna, A log-periodic antenna or horn antenna shall be substituted in place of the EUT. The log-periodic antenna will be driven by a signal generator and the level will be adjusted till the same power value on the spectrum analyzer or receiver. The level of the spurious emissions can be calculated through the level of the signal generator, cable loss, the gain of the substitution antenna and the reading of the spectrum analyzer or receiver.
4. The EUT is then put into continuously transmitting mode at its maximum power level during the test. Set Test Receiver or Spectrum RBW=100kHz, VBW=300kHz for 30MHz to 1GHz and RBW=1MHz, VBW=3MHz for above 1GHz, and the maximum value of the receiver should be recorded as (Pr).
5. The EUT shall be replaced by a substitution antenna. In the chamber, an substitution antenna for the frequency band of interest is placed at the reference point of the chamber. An RF Signal source for the frequency band of interest is connected to the substitution antenna with a cable that has been constructed to not interfere with the radiation pattern of the antenna. A power (PMea) is applied to the input of the substitution antenna, and adjust the level of the signal generator output until the value of the receiver reach the previously recorded (Pr). The power of signal source (PMea) is recorded. The test should be performed by rotating the test item and adjusting the receiving antenna polarization.
6. A amplifier should be connected to the Signal Source output port. And the cable should be connect between the Amplifier and the Substitution Antenna. The cable loss (Pcl) ,the Substitution Antenna Gain (Ga) and the Amplifier Gain (PAg) should be recorded after test.
7. The measurement results are obtained as described below:

$$\text{Power(EIRP)} = \text{PMea} - \text{PAg} - \text{Pcl} + \text{Ga}$$
 The measurement results are amend as described below:

$$\text{Power(EIRP)} = \text{PMea} - \text{Pcl} + \text{Ga}$$
8. This value is EIRP since the measurement is calibrated using an antenna of known gain (2.15 dB) and known input power. ERP can be calculated from EIRP by subtracting the gain of the dipole, $\text{ERP} = \text{EIRP} - 2.15\text{dB}$.

The modulation mode and RB allocation refer to section 5.1, using the maximum output power configuration.

Test setup

9KHz~ 30MHz

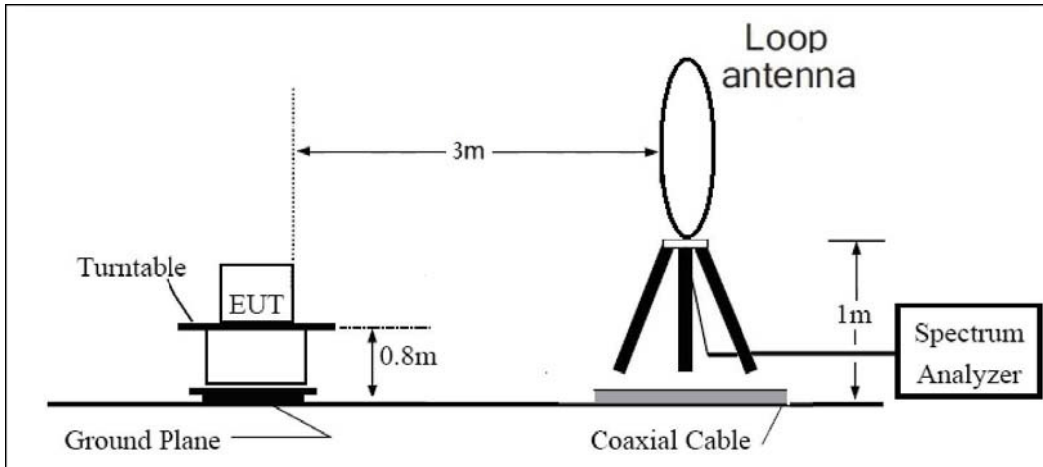

30MHz~ 1GHz

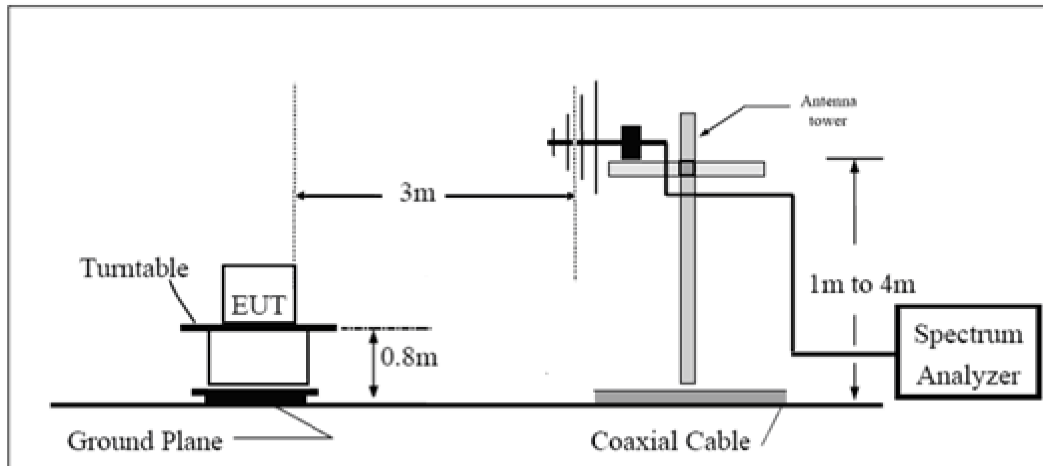

Above 1GHz

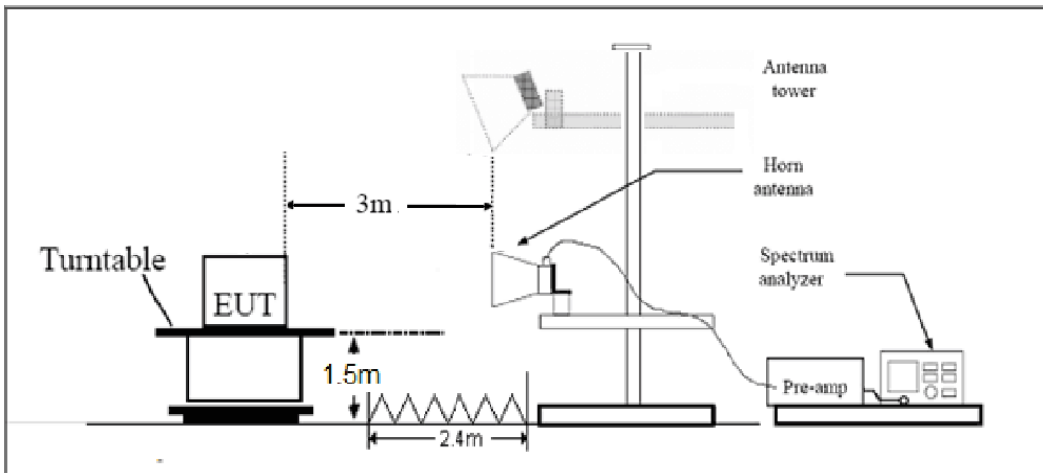

Note: Area side:2.4mX3.6m



Limits

Rule Part 27.53(h) specifies that “for operations in the 1695-1710 MHz, 1710-1755 MHz, 1755-1780 MHz, 1915-1920 MHz, 1995-2000 MHz, 2000-2020 MHz, 2110-2155 MHz, 2155-2180 MHz, and 2180-2200 bands, the power of any emission outside a licensee's frequency block shall be attenuated below the transmitter power (P) in watts by at least $43 + 10 \log_{10}(P)$ dB.”

Rule Part 27.53(m) $55 + 10 \log(P)$ dB on all frequencies more than X megahertz from the channel edge, where X is the greater of 6 megahertz or the actual emission bandwidth as defined in paragraph (m)(4) of this section.

Part 27.53 (h)/(g) Limit	-13 dBm
Part 27.53(m) Limit	-25 dBm

Measurement Uncertainty

The assessed measurement uncertainty to ensure 95% confidence level for the normal distribution is with the coverage factor $k = \pm 1.96$, $U = \pm 3.55$ dB.

Test Results

Refer to the section 6.7 of this report for test data.



6 Test Results

6.1 RF Power Output and Effective Isotropic Radiated Power

Band	Bandwidth (MHz)	UL Channel	RB Size	RB Position	Modulation	Power (dBm)	EIRP (dBm)
LTE Band7	5	20775	1	#0	QPSK	21.93	25.83
LTE Band7	5	20775	1	#Mid	QPSK	22.22	26.12
LTE Band7	5	20775	1	#Max	QPSK	22.06	25.96
LTE Band7	5	20775	12	#0	QPSK	21.08	24.98
LTE Band7	5	20775	12	#Mid	QPSK	21.08	24.98
LTE Band7	5	20775	12	#Max	QPSK	21.13	25.03
LTE Band7	5	20775	25	#0	QPSK	21.21	25.11
LTE Band7	5	20775	1	#0	16QAM	21.12	25.02
LTE Band7	5	20775	1	#Mid	16QAM	21.08	24.98
LTE Band7	5	20775	1	#Max	16QAM	21.14	25.04
LTE Band7	5	20775	12	#0	16QAM	19.96	23.86
LTE Band7	5	20775	12	#Mid	16QAM	19.97	23.87
LTE Band7	5	20775	12	#Max	16QAM	20.03	23.93
LTE Band7	5	20775	25	#0	16QAM	20.07	23.97
LTE Band7	5	21100	1	#0	QPSK	21.42	25.32
LTE Band7	5	21100	1	#Mid	QPSK	21.51	25.41
LTE Band7	5	21100	1	#Max	QPSK	21.50	25.40
LTE Band7	5	21100	12	#0	QPSK	20.65	24.55
LTE Band7	5	21100	12	#Mid	QPSK	20.63	24.53
LTE Band7	5	21100	12	#Max	QPSK	20.63	24.53
LTE Band7	5	21100	25	#0	QPSK	20.68	24.58
LTE Band7	5	21100	1	#0	16QAM	20.67	24.57
LTE Band7	5	21100	1	#Mid	16QAM	20.33	24.23
LTE Band7	5	21100	1	#Max	16QAM	20.21	24.11
LTE Band7	5	21100	12	#0	16QAM	19.49	23.39
LTE Band7	5	21100	12	#Mid	16QAM	19.50	23.40
LTE Band7	5	21100	12	#Max	16QAM	19.69	23.59
LTE Band7	5	21100	25	#0	16QAM	19.56	23.46
LTE Band7	5	21425	1	#0	QPSK	21.40	25.30
LTE Band7	5	21425	1	#Mid	QPSK	21.32	25.22
LTE Band7	5	21425	1	#Max	QPSK	21.20	25.10
LTE Band7	5	21425	12	#0	QPSK	20.56	24.46
LTE Band7	5	21425	12	#Mid	QPSK	20.58	24.48
LTE Band7	5	21425	12	#Max	QPSK	20.63	24.53
LTE Band7	5	21425	25	#0	QPSK	20.56	24.46
LTE Band7	5	21425	1	#0	16QAM	20.85	24.75



LTE Band7	5	21425	1	#Mid	16QAM	20.87	24.77
LTE Band7	5	21425	1	#Max	16QAM	20.59	24.49
LTE Band7	5	21425	12	#0	16QAM	19.32	23.22
LTE Band7	5	21425	12	#Mid	16QAM	19.34	23.24
LTE Band7	5	21425	12	#Max	16QAM	19.19	23.09
LTE Band7	5	21425	25	#0	16QAM	19.34	23.24
LTE Band7	10	20800	1	#0	QPSK	22.16	26.06
LTE Band7	10	20800	1	#Mid	QPSK	22.31	26.21
LTE Band7	10	20800	1	#Max	QPSK	22.31	26.21
LTE Band7	10	20800	25	#0	QPSK	21.07	24.97
LTE Band7	10	20800	25	#Mid	QPSK	21.07	24.97
LTE Band7	10	20800	25	#Max	QPSK	21.31	25.21
LTE Band7	10	20800	50	#0	QPSK	21.24	25.14
LTE Band7	10	20800	1	#0	16QAM	21.16	25.06
LTE Band7	10	20800	1	#Mid	16QAM	22.10	26.00
LTE Band7	10	20800	1	#Max	16QAM	21.27	25.17
LTE Band7	10	20800	25	#0	16QAM	20.19	24.09
LTE Band7	10	20800	25	#Mid	16QAM	20.30	24.20
LTE Band7	10	20800	25	#Max	16QAM	20.42	24.32
LTE Band7	10	20800	50	#0	16QAM	20.17	24.07
LTE Band7	10	21100	1	#0	QPSK	21.73	25.63
LTE Band7	10	21100	1	#Mid	QPSK	21.63	25.53
LTE Band7	10	21100	1	#Max	QPSK	21.67	25.57
LTE Band7	10	21100	25	#0	QPSK	20.53	24.43
LTE Band7	10	21100	25	#Mid	QPSK	20.64	24.54
LTE Band7	10	21100	25	#Max	QPSK	20.71	24.61
LTE Band7	10	21100	50	#0	QPSK	20.63	24.53
LTE Band7	10	21100	1	#0	16QAM	21.16	25.06
LTE Band7	10	21100	1	#Mid	16QAM	21.77	25.67
LTE Band7	10	21100	1	#Max	16QAM	21.36	25.26
LTE Band7	10	21100	25	#0	16QAM	19.70	23.60
LTE Band7	10	21100	25	#Mid	16QAM	19.61	23.51
LTE Band7	10	21100	25	#Max	16QAM	19.60	23.50
LTE Band7	10	21100	50	#0	16QAM	19.55	23.45
LTE Band7	10	21400	1	#0	QPSK	21.58	25.48
LTE Band7	10	21400	1	#Mid	QPSK	21.79	25.69
LTE Band7	10	21400	1	#Max	QPSK	21.83	25.73
LTE Band7	10	21400	25	#0	QPSK	20.56	24.46
LTE Band7	10	21400	25	#Mid	QPSK	20.59	24.49
LTE Band7	10	21400	25	#Max	QPSK	20.53	24.43
LTE Band7	10	21400	50	#0	QPSK	20.53	24.43
LTE Band7	10	21400	1	#0	16QAM	20.74	24.64
LTE Band7	10	21400	1	#Mid	16QAM	21.08	24.98



LTE Band7	10	21400	1	#Max	16QAM	20.16	24.06
LTE Band7	10	21400	25	#0	16QAM	19.67	23.57
LTE Band7	10	21400	25	#Mid	16QAM	19.64	23.54
LTE Band7	10	21400	25	#Max	16QAM	19.38	23.28
LTE Band7	10	21400	50	#0	16QAM	19.42	23.32
LTE Band7	15	20825	1	#0	QPSK	21.99	25.89
LTE Band7	15	20825	1	#Mid	QPSK	22.16	26.06
LTE Band7	15	20825	1	#Max	QPSK	21.92	25.82
LTE Band7	15	20825	36	#0	QPSK	21.11	25.01
LTE Band7	15	20825	36	#Mid	QPSK	21.10	25.00
LTE Band7	15	20825	36	#Max	QPSK	21.17	25.07
LTE Band7	15	20825	75	#0	QPSK	21.08	24.98
LTE Band7	15	20825	1	#0	16QAM	21.27	25.17
LTE Band7	15	20825	1	#Mid	16QAM	21.35	25.25
LTE Band7	15	20825	1	#Max	16QAM	20.97	24.87
LTE Band7	15	20825	36	#0	16QAM	20.14	24.04
LTE Band7	15	20825	36	#Mid	16QAM	20.15	24.05
LTE Band7	15	20825	36	#Max	16QAM	20.13	24.03
LTE Band7	15	20825	75	#0	16QAM	20.06	23.96
LTE Band7	15	21100	1	#0	QPSK	21.85	25.75
LTE Band7	15	21100	1	#Mid	QPSK	21.73	25.63
LTE Band7	15	21100	1	#Max	QPSK	21.65	25.55
LTE Band7	15	21100	36	#0	QPSK	20.64	24.54
LTE Band7	15	21100	36	#Mid	QPSK	20.65	24.55
LTE Band7	15	21100	36	#Max	QPSK	20.61	24.51
LTE Band7	15	21100	75	#0	QPSK	20.57	24.47
LTE Band7	15	21100	1	#0	16QAM	21.28	25.18
LTE Band7	15	21100	1	#Mid	16QAM	21.16	25.06
LTE Band7	15	21100	1	#Max	16QAM	21.17	25.07
LTE Band7	15	21100	36	#0	16QAM	19.58	23.48
LTE Band7	15	21100	36	#Mid	16QAM	19.59	23.49
LTE Band7	15	21100	36	#Max	16QAM	19.68	23.58
LTE Band7	15	21100	75	#0	16QAM	19.44	23.34
LTE Band7	15	21375	1	#0	QPSK	21.44	25.34
LTE Band7	15	21375	1	#Mid	QPSK	21.42	25.32
LTE Band7	15	21375	1	#Max	QPSK	21.36	25.26
LTE Band7	15	21375	36	#0	QPSK	20.60	24.50
LTE Band7	15	21375	36	#Mid	QPSK	20.55	24.45
LTE Band7	15	21375	36	#Max	QPSK	20.44	24.34
LTE Band7	15	21375	75	#0	QPSK	20.58	24.48
LTE Band7	15	21375	1	#0	16QAM	20.53	24.43
LTE Band7	15	21375	1	#Mid	16QAM	20.46	24.36
LTE Band7	15	21375	1	#Max	16QAM	19.79	23.69



LTE Band7	15	21375	36	#0	16QAM	19.56	23.46
LTE Band7	15	21375	36	#Mid	16QAM	19.54	23.44
LTE Band7	15	21375	36	#Max	16QAM	19.34	23.24
LTE Band7	15	21375	75	#0	16QAM	19.46	23.36
LTE Band7	20	20850	1	#0	QPSK	21.84	25.74
LTE Band7	20	20850	1	#Mid	QPSK	22.34	26.24
LTE Band7	20	20850	1	#Max	QPSK	21.78	25.68
LTE Band7	20	20850	50	#0	QPSK	21.11	25.01
LTE Band7	20	20850	50	#Mid	QPSK	21.10	25.00
LTE Band7	20	20850	50	#Max	QPSK	21.09	24.99
LTE Band7	20	20850	100	#0	QPSK	21.02	24.92
LTE Band7	20	20850	1	#0	16QAM	21.05	24.95
LTE Band7	20	20850	1	#Mid	16QAM	21.93	25.83
LTE Band7	20	20850	1	#Max	16QAM	21.04	24.94
LTE Band7	20	20850	50	#0	16QAM	20.24	24.14
LTE Band7	20	20850	50	#Mid	16QAM	20.15	24.05
LTE Band7	20	20850	50	#Max	16QAM	20.14	24.04
LTE Band7	20	20850	100	#0	16QAM	19.97	23.87
LTE Band7	20	21100	1	#0	QPSK	21.95	25.85
LTE Band7	20	21100	1	#Mid	QPSK	22.04	25.94
LTE Band7	20	21100	1	#Max	QPSK	21.72	25.62
LTE Band7	20	21100	50	#0	QPSK	20.66	24.56
LTE Band7	20	21100	50	#Mid	QPSK	20.67	24.57
LTE Band7	20	21100	50	#Max	QPSK	20.67	24.57
LTE Band7	20	21100	100	#0	QPSK	20.64	24.54
LTE Band7	20	21100	1	#0	16QAM	20.46	24.36
LTE Band7	20	21100	1	#Mid	16QAM	20.40	24.30
LTE Band7	20	21100	1	#Max	16QAM	20.31	24.21
LTE Band7	20	21100	50	#0	16QAM	19.59	23.49
LTE Band7	20	21100	50	#Mid	16QAM	19.60	23.50
LTE Band7	20	21100	50	#Max	16QAM	19.69	23.59
LTE Band7	20	21100	100	#0	16QAM	19.62	23.52
LTE Band7	20	21350	1	#0	QPSK	21.49	25.39
LTE Band7	20	21350	1	#Mid	QPSK	21.87	25.77
LTE Band7	20	21350	1	#Max	QPSK	21.59	25.49
LTE Band7	20	21350	50	#0	QPSK	20.73	24.63
LTE Band7	20	21350	50	#Mid	QPSK	20.66	24.56
LTE Band7	20	21350	50	#Max	QPSK	20.57	24.47
LTE Band7	20	21350	100	#0	QPSK	20.58	24.48
LTE Band7	20	21350	1	#0	16QAM	20.73	24.63
LTE Band7	20	21350	1	#Mid	16QAM	20.89	24.79
LTE Band7	20	21350	1	#Max	16QAM	19.96	23.86
LTE Band7	20	21350	50	#0	16QAM	19.63	23.53



LTE Band7	20	21350	50	#Mid	16QAM	19.65	23.55
LTE Band7	20	21350	50	#Max	16QAM	19.39	23.29
LTE Band7	20	21350	100	#0	16QAM	19.65	23.55

Band	Bandwidth (MHz)	UL Channel	RB Size	RB Position	Modulation	Power (dBm)	EIRP (dBm)
LTE Band66	1.4	131979	1	#0	QPSK	24.15	26.65
LTE Band66	1.4	131979	1	#Mid	QPSK	24.19	26.69
LTE Band66	1.4	131979	1	#Max	QPSK	24.34	26.84
LTE Band66	1.4	131979	3	#0	QPSK	24.33	26.83
LTE Band66	1.4	131979	3	#Mid	QPSK	24.12	26.62
LTE Band66	1.4	131979	3	#Max	QPSK	24.05	26.55
LTE Band66	1.4	131979	6	#0	QPSK	23.22	25.72
LTE Band66	1.4	131979	1	#0	16QAM	22.71	25.21
LTE Band66	1.4	131979	1	#Mid	16QAM	22.99	25.49
LTE Band66	1.4	131979	1	#Max	16QAM	23.11	25.61
LTE Band66	1.4	131979	3	#0	16QAM	22.99	25.49
LTE Band66	1.4	131979	3	#Mid	16QAM	23.09	25.59
LTE Band66	1.4	131979	3	#Max	16QAM	23.02	25.52
LTE Band66	1.4	131979	6	#0	16QAM	21.99	24.49
LTE Band66	1.4	132322	1	#0	QPSK	24.41	26.91
LTE Band66	1.4	132322	1	#Mid	QPSK	24.50	27.00
LTE Band66	1.4	132322	1	#Max	QPSK	24.40	26.90
LTE Band66	1.4	132322	3	#0	QPSK	24.23	26.73
LTE Band66	1.4	132322	3	#Mid	QPSK	24.23	26.73
LTE Band66	1.4	132322	3	#Max	QPSK	24.23	26.73
LTE Band66	1.4	132322	6	#0	QPSK	23.17	25.67
LTE Band66	1.4	132322	1	#0	16QAM	23.48	25.98
LTE Band66	1.4	132322	1	#Mid	16QAM	23.59	26.09
LTE Band66	1.4	132322	1	#Max	16QAM	23.40	25.90
LTE Band66	1.4	132322	3	#0	16QAM	23.26	25.76
LTE Band66	1.4	132322	3	#Mid	16QAM	23.19	25.69
LTE Band66	1.4	132322	3	#Max	16QAM	23.22	25.72
LTE Band66	1.4	132322	6	#0	16QAM	22.12	24.62
LTE Band66	1.4	132665	1	#0	QPSK	23.13	25.63
LTE Band66	1.4	132665	1	#Mid	QPSK	23.03	25.53
LTE Band66	1.4	132665	1	#Max	QPSK	22.98	25.48
LTE Band66	1.4	132665	3	#0	QPSK	22.93	25.43
LTE Band66	1.4	132665	3	#Mid	QPSK	22.93	25.43
LTE Band66	1.4	132665	3	#Max	QPSK	22.90	25.40
LTE Band66	1.4	132665	6	#0	QPSK	22.94	25.44
LTE Band66	1.4	132665	1	#0	16QAM	22.32	24.82
LTE Band66	1.4	132665	1	#Mid	16QAM	22.29	24.79



LTE Band66	1.4	132665	1	#Max	16QAM	22.14	24.64
LTE Band66	1.4	132665	3	#0	16QAM	22.17	24.67
LTE Band66	1.4	132665	3	#Mid	16QAM	22.18	24.68
LTE Band66	1.4	132665	3	#Max	16QAM	22.04	24.54
LTE Band66	1.4	132665	6	#0	16QAM	22.04	24.54
LTE Band66	3	131987	1	#0	QPSK	24.04	26.54
LTE Band66	3	131987	1	#Mid	QPSK	24.25	26.75
LTE Band66	3	131987	1	#Max	QPSK	24.12	26.62
LTE Band66	3	131987	8	#0	QPSK	23.12	25.62
LTE Band66	3	131987	8	#Mid	QPSK	23.12	25.62
LTE Band66	3	131987	8	#Max	QPSK	23.24	25.74
LTE Band66	3	131987	15	#0	QPSK	23.18	25.68
LTE Band66	3	131987	1	#0	16QAM	23.21	25.71
LTE Band66	3	131987	1	#Mid	16QAM	23.36	25.86
LTE Band66	3	131987	1	#Max	16QAM	23.17	25.67
LTE Band66	3	131987	8	#0	16QAM	21.92	24.42
LTE Band66	3	131987	8	#Mid	16QAM	22.21	24.71
LTE Band66	3	131987	8	#Max	16QAM	22.48	24.98
LTE Band66	3	131987	15	#0	16QAM	22.15	24.65
LTE Band66	3	132322	1	#0	QPSK	24.37	26.87
LTE Band66	3	132322	1	#Mid	QPSK	24.28	26.78
LTE Band66	3	132322	1	#Max	QPSK	24.28	26.78
LTE Band66	3	132322	8	#0	QPSK	23.07	25.57
LTE Band66	3	132322	8	#Mid	QPSK	23.08	25.58
LTE Band66	3	132322	8	#Max	QPSK	23.11	25.61
LTE Band66	3	132322	15	#0	QPSK	23.07	25.57
LTE Band66	3	132322	1	#0	16QAM	23.65	26.15
LTE Band66	3	132322	1	#Mid	16QAM	23.68	26.18
LTE Band66	3	132322	1	#Max	16QAM	23.67	26.17
LTE Band66	3	132322	8	#0	16QAM	22.18	24.68
LTE Band66	3	132322	8	#Mid	16QAM	22.19	24.69
LTE Band66	3	132322	8	#Max	16QAM	22.22	24.72
LTE Band66	3	132322	15	#0	16QAM	21.86	24.36
LTE Band66	3	132657	1	#0	QPSK	23.37	25.87
LTE Band66	3	132657	1	#Mid	QPSK	23.21	25.71
LTE Band66	3	132657	1	#Max	QPSK	23.02	25.52
LTE Band66	3	132657	8	#0	QPSK	23.24	25.74
LTE Band66	3	132657	8	#Mid	QPSK	23.23	25.73
LTE Band66	3	132657	8	#Max	QPSK	22.98	25.48
LTE Band66	3	132657	15	#0	QPSK	23.07	25.57
LTE Band66	3	132657	1	#0	16QAM	22.25	24.75
LTE Band66	3	132657	1	#Mid	16QAM	22.19	24.69
LTE Band66	3	132657	1	#Max	16QAM	21.85	24.35



LTE Band66	3	132657	8	#0	16QAM	22.33	24.83
LTE Band66	3	132657	8	#Mid	16QAM	22.34	24.84
LTE Band66	3	132657	8	#Max	16QAM	22.15	24.65
LTE Band66	3	132657	15	#0	16QAM	22.22	24.72
LTE Band66	5	131997	1	#0	QPSK	23.94	26.44
LTE Band66	5	131997	1	#Mid	QPSK	24.05	26.55
LTE Band66	5	131997	1	#Max	QPSK	24.07	26.57
LTE Band66	5	131997	12	#0	QPSK	23.03	25.53
LTE Band66	5	131997	12	#Mid	QPSK	23.03	25.53
LTE Band66	5	131997	12	#Max	QPSK	23.18	25.68
LTE Band66	5	131997	25	#0	QPSK	23.09	25.59
LTE Band66	5	131997	1	#0	16QAM	23.12	25.62
LTE Band66	5	131997	1	#Mid	16QAM	23.12	25.62
LTE Band66	5	131997	1	#Max	16QAM	23.11	25.61
LTE Band66	5	131997	12	#0	16QAM	21.91	24.41
LTE Band66	5	131997	12	#Mid	16QAM	22.02	24.52
LTE Band66	5	131997	12	#Max	16QAM	22.08	24.58
LTE Band66	5	131997	25	#0	16QAM	22.12	24.62
LTE Band66	5	132322	1	#0	QPSK	24.21	26.71
LTE Band66	5	132322	1	#Mid	QPSK	24.18	26.68
LTE Band66	5	132322	1	#Max	QPSK	24.19	26.69
LTE Band66	5	132322	12	#0	QPSK	23.27	25.77
LTE Band66	5	132322	12	#Mid	QPSK	23.27	25.77
LTE Band66	5	132322	12	#Max	QPSK	23.19	25.69
LTE Band66	5	132322	25	#0	QPSK	23.14	25.64
LTE Band66	5	132322	1	#0	16QAM	23.42	25.92
LTE Band66	5	132322	1	#Mid	16QAM	23.80	26.30
LTE Band66	5	132322	1	#Max	16QAM	23.88	26.38
LTE Band66	5	132322	12	#0	16QAM	22.01	24.51
LTE Band66	5	132322	12	#Mid	16QAM	22.02	24.52
LTE Band66	5	132322	12	#Max	16QAM	22.06	24.56
LTE Band66	5	132322	25	#0	16QAM	22.01	24.51
LTE Band66	5	132647	1	#0	QPSK	23.57	26.07
LTE Band66	5	132647	1	#Mid	QPSK	23.26	25.76
LTE Band66	5	132647	1	#Max	QPSK	22.85	25.35
LTE Band66	5	132647	12	#0	QPSK	23.41	25.91
LTE Band66	5	132647	12	#Mid	QPSK	23.03	25.53
LTE Band66	5	132647	12	#Max	QPSK	22.92	25.42
LTE Band66	5	132647	25	#0	QPSK	23.07	25.57
LTE Band66	5	132647	1	#0	16QAM	22.81	25.31
LTE Band66	5	132647	1	#Mid	16QAM	22.59	25.09
LTE Band66	5	132647	1	#Max	16QAM	22.10	24.60
LTE Band66	5	132647	12	#0	16QAM	22.55	25.05



LTE Band66	5	132647	12	#Mid	16QAM	22.19	24.69
LTE Band66	5	132647	12	#Max	16QAM	21.83	24.33
LTE Band66	5	132647	25	#0	16QAM	21.84	24.34
LTE Band66	10	132022	1	#0	QPSK	23.67	26.17
LTE Band66	10	132022	1	#Mid	QPSK	24.74	27.24
LTE Band66	10	132022	1	#Max	QPSK	24.08	26.58
LTE Band66	10	132022	25	#0	QPSK	23.13	25.63
LTE Band66	10	132022	25	#Mid	QPSK	23.14	25.64
LTE Band66	10	132022	25	#Max	QPSK	23.23	25.73
LTE Band66	10	132022	50	#0	QPSK	23.11	25.61
LTE Band66	10	132022	1	#0	16QAM	22.92	25.42
LTE Band66	10	132022	1	#Mid	16QAM	24.05	26.55
LTE Band66	10	132022	1	#Max	16QAM	23.40	25.90
LTE Band66	10	132022	25	#0	16QAM	22.35	24.85
LTE Band66	10	132022	25	#Mid	16QAM	22.33	24.83
LTE Band66	10	132022	25	#Max	16QAM	22.31	24.81
LTE Band66	10	132022	50	#0	16QAM	22.11	24.61
LTE Band66	10	132322	1	#0	QPSK	24.31	26.81
LTE Band66	10	132322	1	#Mid	QPSK	24.45	26.95
LTE Band66	10	132322	1	#Max	QPSK	24.16	26.66
LTE Band66	10	132322	25	#0	QPSK	23.14	25.64
LTE Band66	10	132322	25	#Mid	QPSK	23.14	25.64
LTE Band66	10	132322	25	#Max	QPSK	23.29	25.79
LTE Band66	10	132322	50	#0	QPSK	23.15	25.65
LTE Band66	10	132322	1	#0	16QAM	23.60	26.10
LTE Band66	10	132322	1	#Mid	16QAM	24.54	27.04
LTE Band66	10	132322	1	#Max	16QAM	23.65	26.15
LTE Band66	10	132322	25	#0	16QAM	22.37	24.87
LTE Band66	10	132322	25	#Mid	16QAM	22.28	24.78
LTE Band66	10	132322	25	#Max	16QAM	22.41	24.91
LTE Band66	10	132322	50	#0	16QAM	22.24	24.74
LTE Band66	10	132622	1	#0	QPSK	23.44	25.94
LTE Band66	10	132622	1	#Mid	QPSK	23.74	26.24
LTE Band66	10	132622	1	#Max	QPSK	22.17	24.67
LTE Band66	10	132622	25	#0	QPSK	23.51	26.01
LTE Band66	10	132622	25	#Mid	QPSK	23.08	25.58
LTE Band66	10	132622	25	#Max	QPSK	22.99	25.49
LTE Band66	10	132622	50	#0	QPSK	23.08	25.58
LTE Band66	10	132622	1	#0	16QAM	22.23	24.73
LTE Band66	10	132622	1	#Mid	16QAM	22.69	25.19
LTE Band66	10	132622	1	#Max	16QAM	21.10	23.60
LTE Band66	10	132622	25	#0	16QAM	22.54	25.04
LTE Band66	10	132622	25	#Mid	16QAM	22.09	24.59



LTE Band66	10	132622	25	#Max	16QAM	21.96	24.46
LTE Band66	10	132622	50	#0	16QAM	22.10	24.60
LTE Band66	15	132047	1	#0	QPSK	23.56	26.06
LTE Band66	15	132047	1	#Mid	QPSK	24.62	27.12
LTE Band66	15	132047	1	#Max	QPSK	24.08	26.58
LTE Band66	15	132047	36	#0	QPSK	23.24	25.74
LTE Band66	15	132047	36	#Mid	QPSK	23.11	25.61
LTE Band66	15	132047	36	#Max	QPSK	23.20	25.70
LTE Band66	15	132047	75	#0	QPSK	23.19	25.69
LTE Band66	15	132047	1	#0	16QAM	22.80	25.30
LTE Band66	15	132047	1	#Mid	16QAM	24.13	26.63
LTE Band66	15	132047	1	#Max	16QAM	23.37	25.87
LTE Band66	15	132047	36	#0	16QAM	22.25	24.75
LTE Band66	15	132047	36	#Mid	16QAM	22.26	24.76
LTE Band66	15	132047	36	#Max	16QAM	22.22	24.72
LTE Band66	15	132047	75	#0	16QAM	22.26	24.76
LTE Band66	15	132322	1	#0	QPSK	24.22	26.72
LTE Band66	15	132322	1	#Mid	QPSK	24.38	26.88
LTE Band66	15	132322	1	#Max	QPSK	24.06	26.56
LTE Band66	15	132322	36	#0	QPSK	23.13	25.63
LTE Band66	15	132322	36	#Mid	QPSK	23.13	25.63
LTE Band66	15	132322	36	#Max	QPSK	23.24	25.74
LTE Band66	15	132322	75	#0	QPSK	23.16	25.66
LTE Band66	15	132322	1	#0	16QAM	23.36	25.86
LTE Band66	15	132322	1	#Mid	16QAM	24.47	26.97
LTE Band66	15	132322	1	#Max	16QAM	23.47	25.97
LTE Band66	15	132322	36	#0	16QAM	22.22	24.72
LTE Band66	15	132322	36	#Mid	16QAM	22.23	24.73
LTE Band66	15	132322	36	#Max	16QAM	22.41	24.91
LTE Band66	15	132322	75	#0	16QAM	22.17	24.67
LTE Band66	15	132597	1	#0	QPSK	23.85	26.35
LTE Band66	15	132597	1	#Mid	QPSK	23.83	26.33
LTE Band66	15	132597	1	#Max	QPSK	22.03	24.53
LTE Band66	15	132597	36	#0	QPSK	23.42	25.92
LTE Band66	15	132597	36	#Mid	QPSK	23.17	25.67
LTE Band66	15	132597	36	#Max	QPSK	22.89	25.39
LTE Band66	15	132597	75	#0	QPSK	23.04	25.54
LTE Band66	15	132597	1	#0	16QAM	22.70	25.20
LTE Band66	15	132597	1	#Mid	16QAM	22.50	25.00
LTE Band66	15	132597	1	#Max	16QAM	21.19	23.69
LTE Band66	15	132597	36	#0	16QAM	22.43	24.93
LTE Band66	15	132597	36	#Mid	16QAM	22.13	24.63
LTE Band66	15	132597	36	#Max	16QAM	21.81	24.31



LTE Band66	15	132597	75	#0	16QAM	22.11	24.61
LTE Band66	20	132072	1	#0	QPSK	23.34	25.84
LTE Band66	20	132072	1	#Mid	QPSK	24.75	27.25
LTE Band66	20	132072	1	#Max	QPSK	23.92	26.42
LTE Band66	20	132072	50	#0	QPSK	23.04	25.54
LTE Band66	20	132072	50	#Mid	QPSK	23.20	25.70
LTE Band66	20	132072	50	#Max	QPSK	23.15	25.65
LTE Band66	20	132072	100	#0	QPSK	23.21	25.71
LTE Band66	20	132072	1	#0	16QAM	22.49	24.99
LTE Band66	20	132072	1	#Mid	16QAM	24.14	26.64
LTE Band66	20	132072	1	#Max	16QAM	23.11	25.61
LTE Band66	20	132072	50	#0	16QAM	22.35	24.85
LTE Band66	20	132072	50	#Mid	16QAM	22.30	24.80
LTE Band66	20	132072	50	#Max	16QAM	22.28	24.78
LTE Band66	20	132072	100	#0	16QAM	22.20	24.70
LTE Band66	20	132322	1	#0	QPSK	24.04	26.54
LTE Band66	20	132322	1	#Mid	QPSK	24.95	27.45
LTE Band66	20	132322	1	#Max	QPSK	24.07	26.57
LTE Band66	20	132322	50	#0	QPSK	23.32	25.82
LTE Band66	20	132322	50	#Mid	QPSK	23.33	25.83
LTE Band66	20	132322	50	#Max	QPSK	23.29	25.79
LTE Band66	20	132322	100	#0	QPSK	23.14	25.64
LTE Band66	20	132322	1	#0	16QAM	22.82	25.32
LTE Band66	20	132322	1	#Mid	16QAM	23.06	25.56
LTE Band66	20	132322	1	#Max	16QAM	22.32	24.82
LTE Band66	20	132322	50	#0	16QAM	22.18	24.68
LTE Band66	20	132322	50	#Mid	16QAM	22.19	24.69
LTE Band66	20	132322	50	#Max	16QAM	22.37	24.87
LTE Band66	20	132322	100	#0	16QAM	22.23	24.73
LTE Band66	20	132572	1	#0	QPSK	23.76	26.26
LTE Band66	20	132572	1	#Mid	QPSK	24.07	26.57
LTE Band66	20	132572	1	#Max	QPSK	21.85	24.35
LTE Band66	20	132572	50	#0	QPSK	23.40	25.90
LTE Band66	20	132572	50	#Mid	QPSK	23.20	25.70
LTE Band66	20	132572	50	#Max	QPSK	22.90	25.40
LTE Band66	20	132572	100	#0	QPSK	23.09	25.59
LTE Band66	20	132572	1	#0	16QAM	22.49	24.99
LTE Band66	20	132572	1	#Mid	16QAM	22.90	25.40
LTE Band66	20	132572	1	#Max	16QAM	20.69	23.19
LTE Band66	20	132572	50	#0	16QAM	22.47	24.97
LTE Band66	20	132572	50	#Mid	16QAM	22.06	24.56
LTE Band66	20	132572	50	#Max	16QAM	21.90	24.40
LTE Band66	20	132572	100	#0	16QAM	22.07	24.57



6.2 Occupied Bandwidth

LTE Band 7						
RB	Modulation	Bandwidth (MHz)	Channel	Frequency (MHz)	99% Power Bandwidth(MHz)	-26dBc Bandwidth(MHz)
100%	QPSK	5	20775	2502.5	4.510	4.954
			21100	2535	4.514	4.969
			21425	2567.5	4.510	4.984
		10	20800	2505	8.954	9.852
			21100	2535	8.946	9.828
			21400	2565	8.961	9.832
		15	20825	2507.5	13.481	14.636
			21100	2535	13.405	14.544
			21375	2562.5	13.403	14.520
		20	20850	2510	17.959	19.291
			21100	2535	17.894	19.257
			21350	2560	17.900	19.462
	16QAM	5	20775	2502.5	4.527	4.971
			21100	2535	4.506	4.960
			21425	2567.5	4.522	4.920
		10	20800	2505	8.941	9.792
			21100	2535	8.968	9.730
			21400	2565	8.973	9.765
		15	20825	2507.5	13.441	14.553
			21100	2535	13.443	14.501
			21375	2562.5	13.422	14.546
		20	20850	2510	17.880	19.385
			21100	2535	17.888	19.328
			21350	2560	17.881	19.498



LTE Band 66						
RB	Modulation	Bandwidth (MHz)	Channel	Frequency (MHz)	99% Power Bandwidth(MHz)	-26dBc Bandwidth(MHz)
100%	QPSK	1.4	131979	1710.7	1.102	1.282
			132322	1745	1.090	1.293
			132665	1779.3	1.094	1.298
		3	131987	1711.5	2.708	2.966
			132322	1745	2.723	2.991
			132657	1778.5	2.709	2.995
		5	131997	1712.5	4.512	5.041
			132322	1745	4.526	5.020
			132647	1777.5	4.511	4.989
		10	132022	1715	8.984	9.781
			132322	1745	8.973	9.887
			132622	1775	8.962	9.787
		15	132047	1717.5	13.441	14.575
			132322	1745	13.406	14.465
			132597	1772.5	13.437	14.595
		20	132072	1720	17.871	19.166
			132322	1745	17.875	19.306
			132572	1770	17.906	19.234
	16QAM	1.4	131979	1710.7	1.099	1.279
			132322	1745	1.102	1.310
			132665	1779.3	1.094	1.268
		3	131987	1711.5	2.702	2.951
			132322	1745	2.704	3.006
			132657	1778.5	2.705	3.000
		5	131997	1712.5	4.517	4.947
			132322	1745	4.529	5.080
			132647	1777.5	4.523	5.031
		10	132022	1715	8.976	9.826
			132322	1745	8.978	9.699
			132622	1775	8.970	9.765
15		132047	1717.5	13.425	14.488	
		132322	1745	13.457	14.648	
		132597	1772.5	13.429	14.627	
20		132072	1720	17.944	19.429	
		132322	1745	17.866	19.320	
		132572	1770	17.873	19.352	



LTE Band 7 QPSK 5MHz CH-Low



LTE Band 7 QPSK 10MHz CH-Low



LTE Band 7 QPSK 5MHz CH-Middle

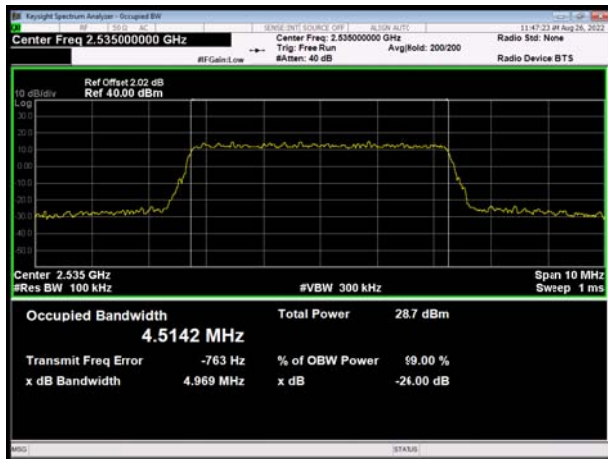

LTE Band 7 QPSK 10MHz CH-Middle



LTE Band 7 QPSK 5MHz CH-High

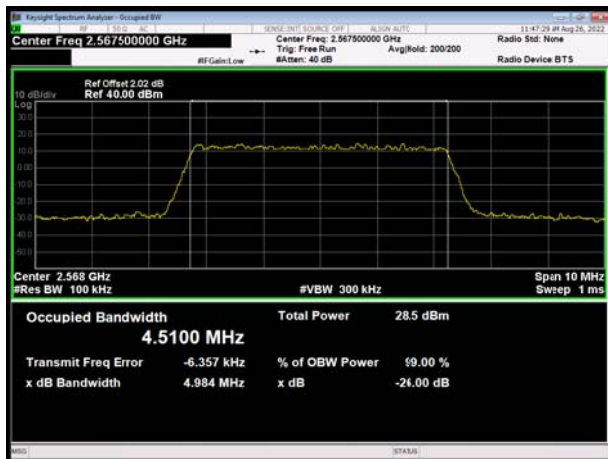

LTE Band 7 QPSK 10MHz CH-High

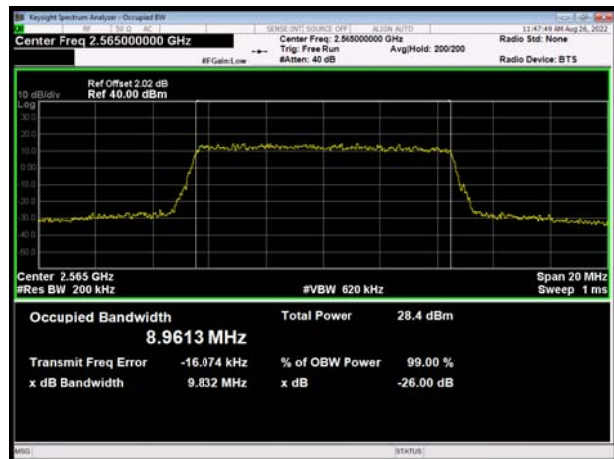



LTE Band 7 QPSK 15MHz CH-Low



LTE Band 7 QPSK 20MHz CH-Low



LTE Band 7 QPSK 15MHz CH-Middle

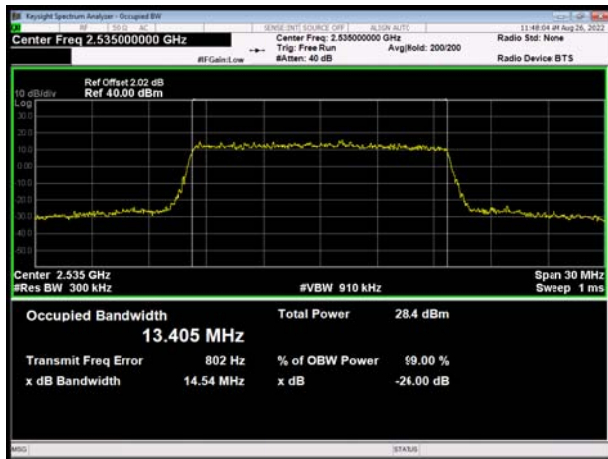

LTE Band 7 QPSK 20MHz CH-Middle



LTE Band 7 QPSK 15MHz CH-High

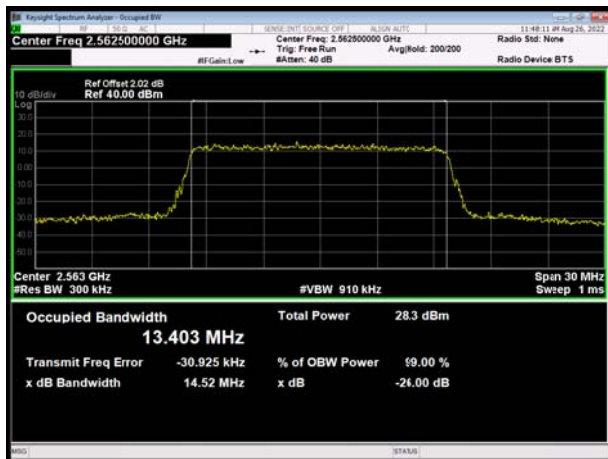

LTE Band 7 QPSK 20MHz CH-High

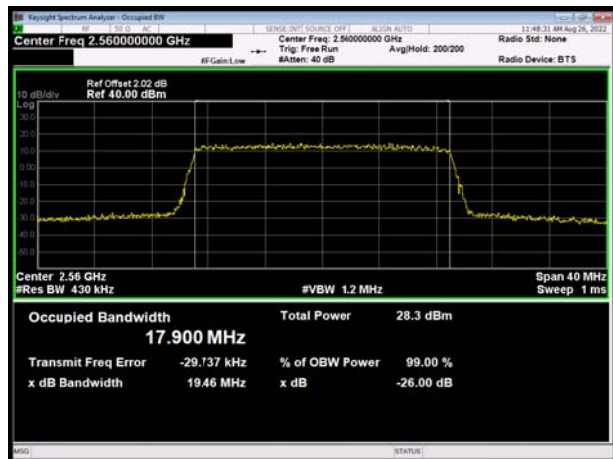

LTE Band 7 16QAM 5MHz CH-Low

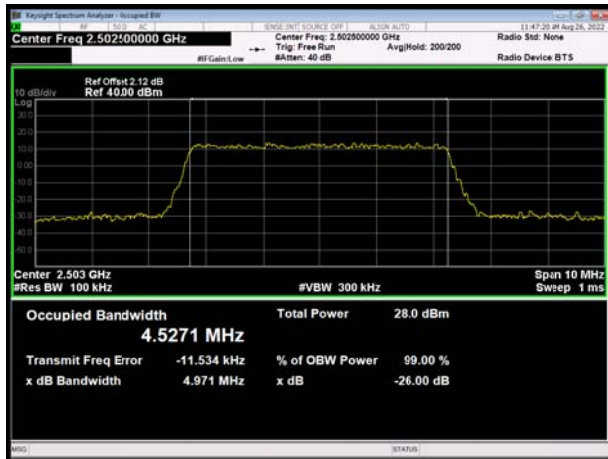

LTE Band 7 16QAM 10MHz CH-Low



LTE Band 7 16QAM 5MHz CH-Middle

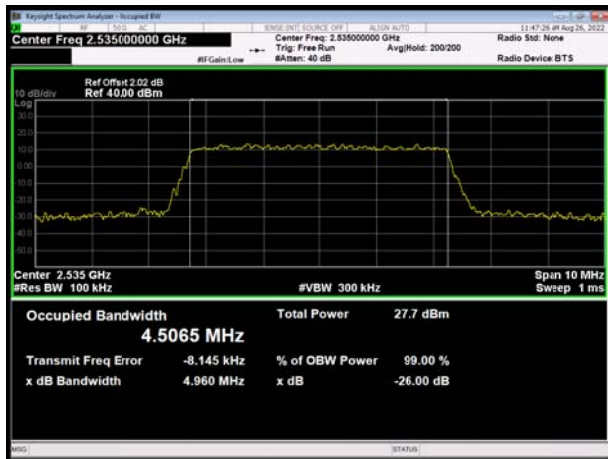

LTE Band 7 16QAM 10MHz CH-Middle



LTE Band 7 16QAM 5MHz CH-High

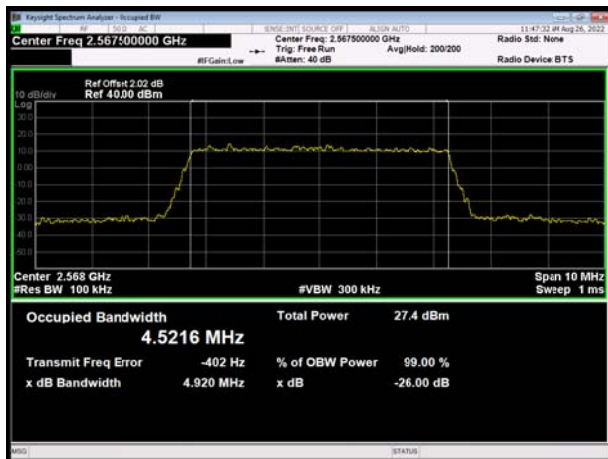

LTE Band 7 16QAM 10MHz CH-High





LTE Band 7 16QAM 15MHz CH-Low

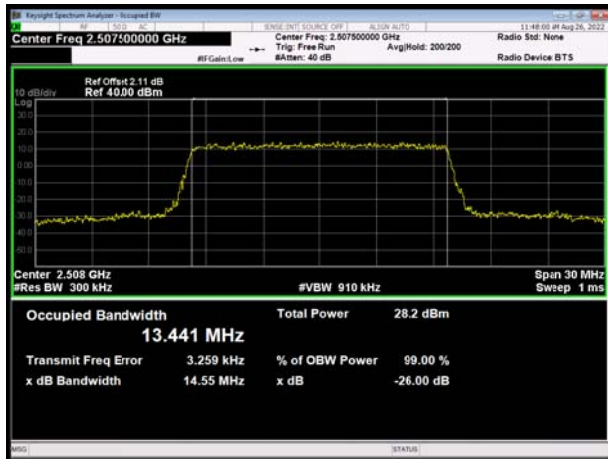

LTE Band 7 16QAM 20MHz CH-Low

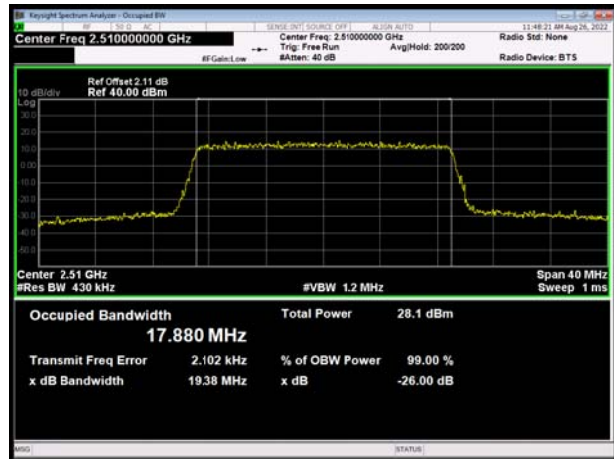

LTE Band 7 16QAM 15MHz CH-Middle

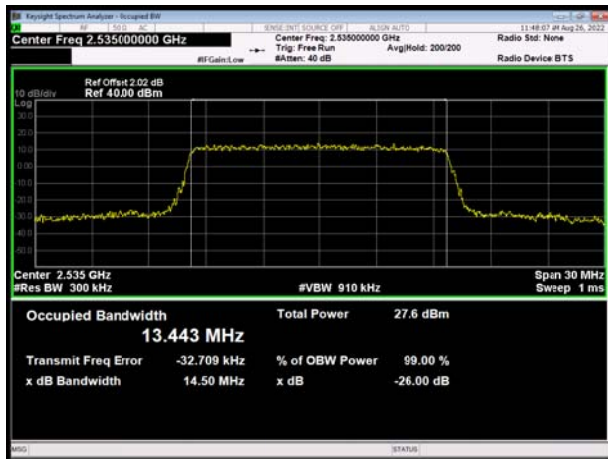

LTE Band 7 16QAM 20MHz CH-Middle

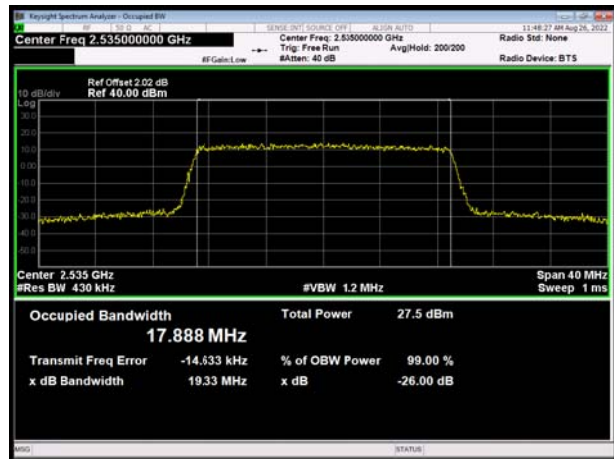

LTE Band 7 16QAM 15MHz CH-High

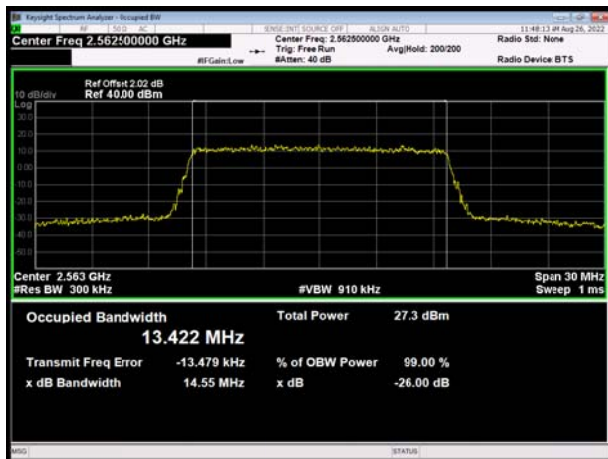

LTE Band 7 16QAM 20MHz CH-High

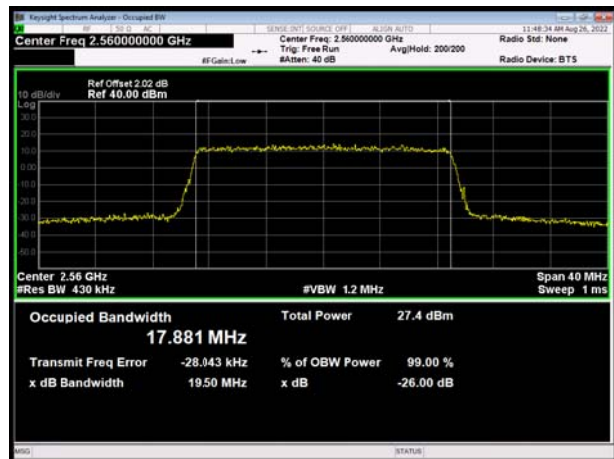



LTE Band 66 QPSK 1.4MHz CH-Low

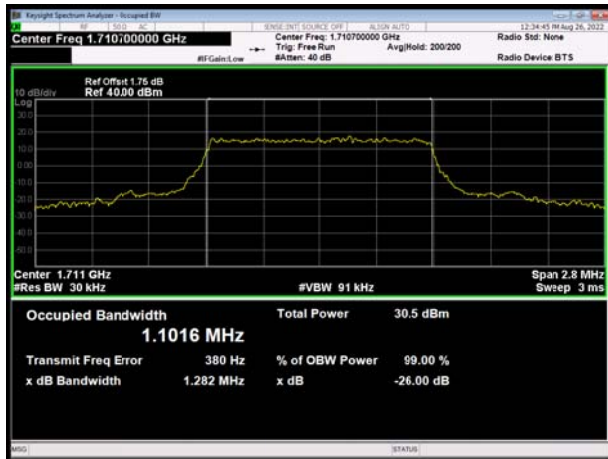

LTE Band 66 QPSK 3MHz CH-Low

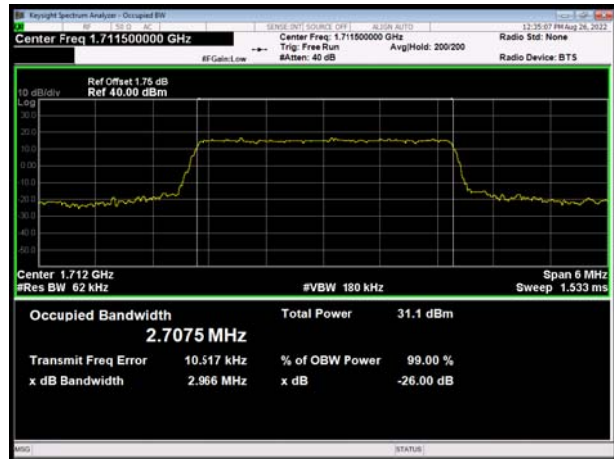

LTE Band 66 QPSK 1.4MHz CH-Middle

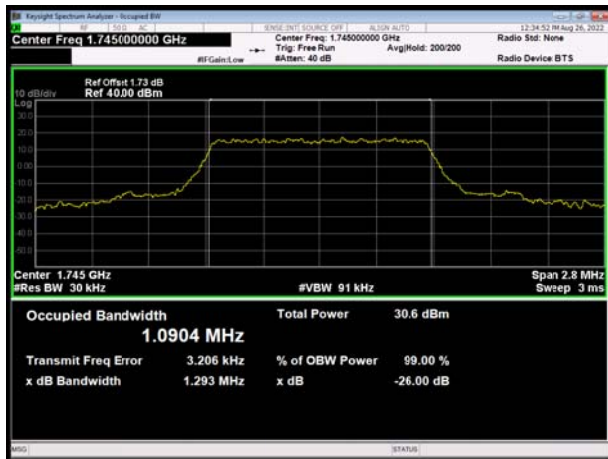

LTE Band 66 QPSK 3MHz CH-Middle



LTE Band 66 QPSK 1.4MHz CH-High

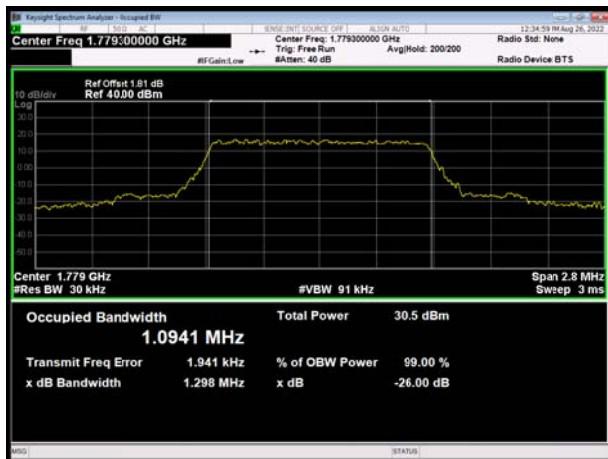

LTE Band 66 QPSK 3MHz CH-High





LTE Band 66 QPSK 5MHz CH-Low



LTE Band 66 QPSK 10MHz CH-Low



LTE Band 66 QPSK 5MHz CH-Middle



LTE Band 66 QPSK 10MHz CH-Middle



LTE Band 66 QPSK 5MHz CH-High

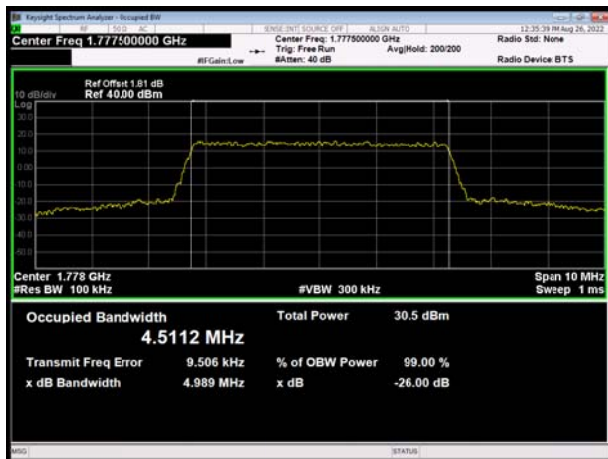

LTE Band 66 QPSK 10MHz CH-High





LTE Band 66 QPSK 15MHz CH-Low

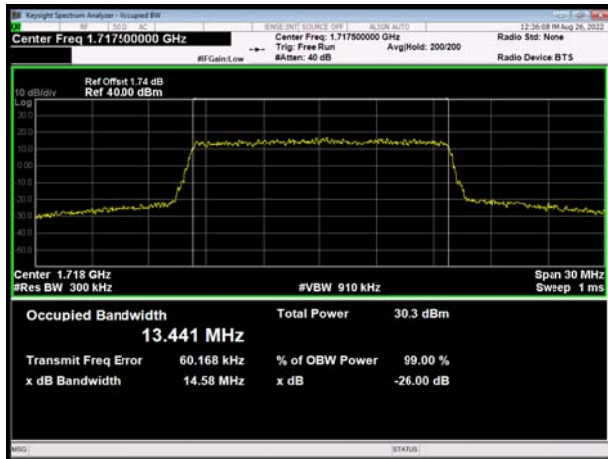

LTE Band 66 QPSK 20MHz CH-Low

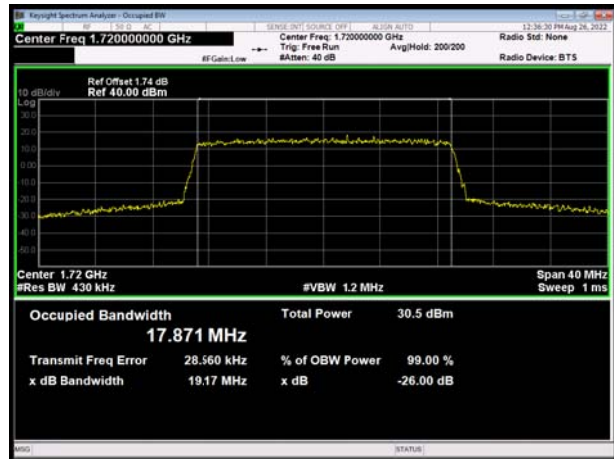

LTE Band 66 QPSK 15MHz CH-Middle



LTE Band 66 QPSK 20MHz CH-Middle



LTE Band 66 QPSK 15MHz CH-High

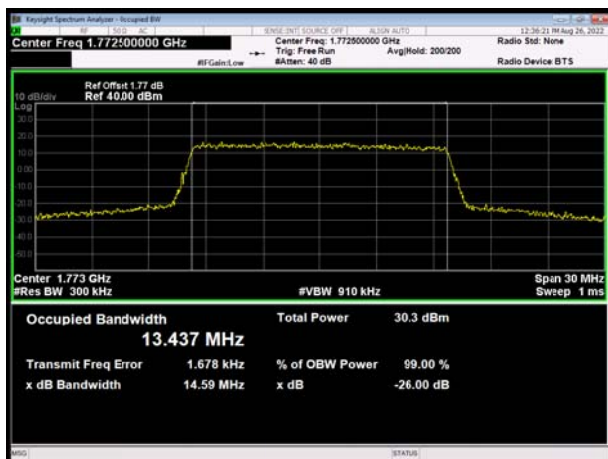

LTE Band 66 QPSK 20MHz CH-High

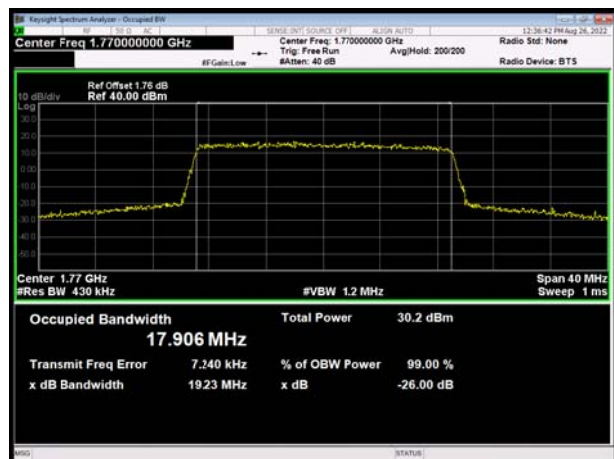



LTE Band 66 16QAM 1.4MHz CH-Low

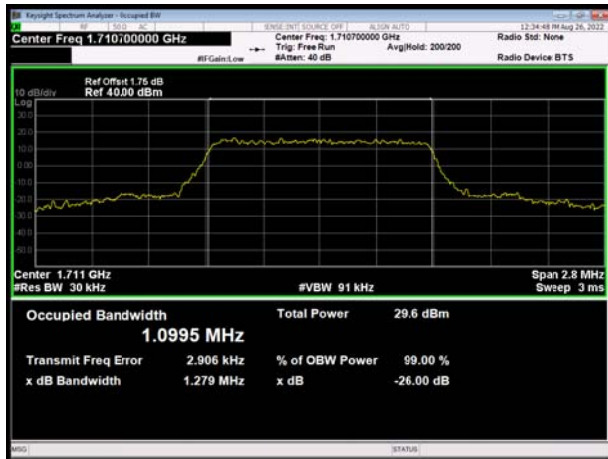

LTE Band 66 16QAM 3MHz CH-Low

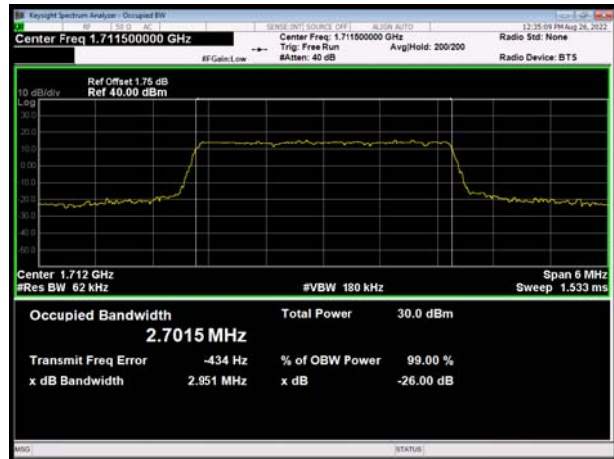

LTE Band 66 16QAM 1.4MHz CH-Middle

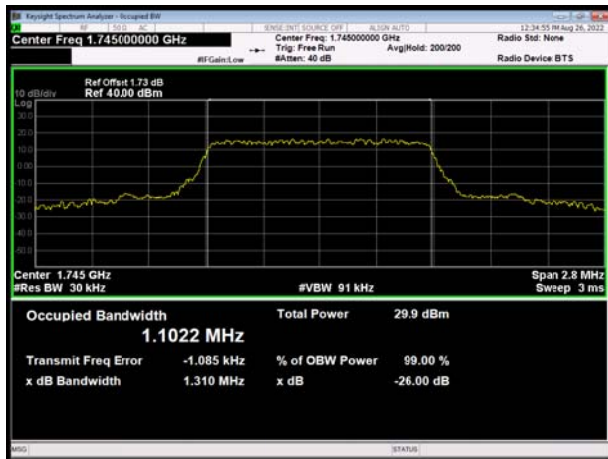

LTE Band 66 16QAM 3MHz CH-Middle

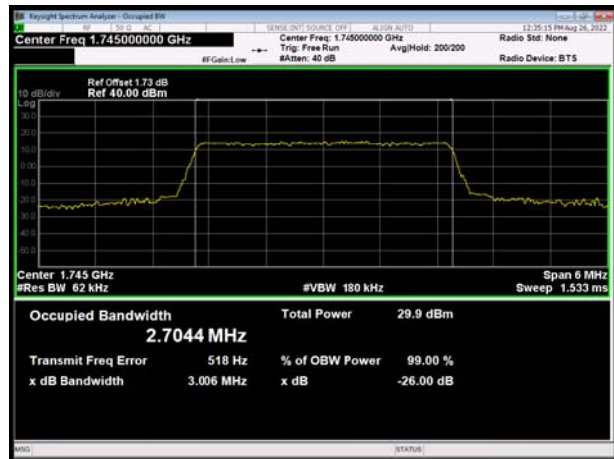

LTE Band 66 16QAM 1.4MHz CH-High

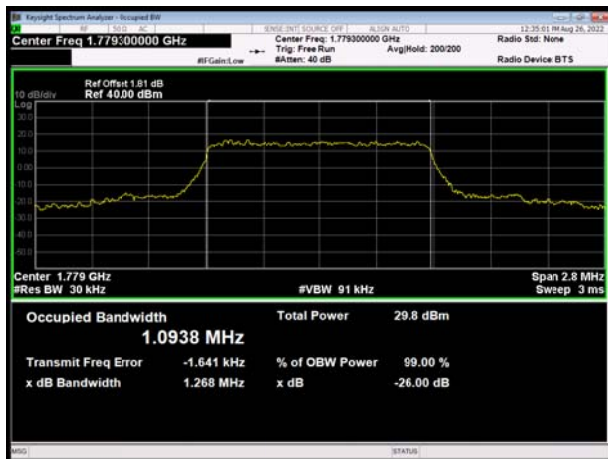

LTE Band 66 16QAM 3MHz CH-High





LTE Band 66 16QAM 5MHz CH-Low



LTE Band 66 16QAM 10MHz CH-Low

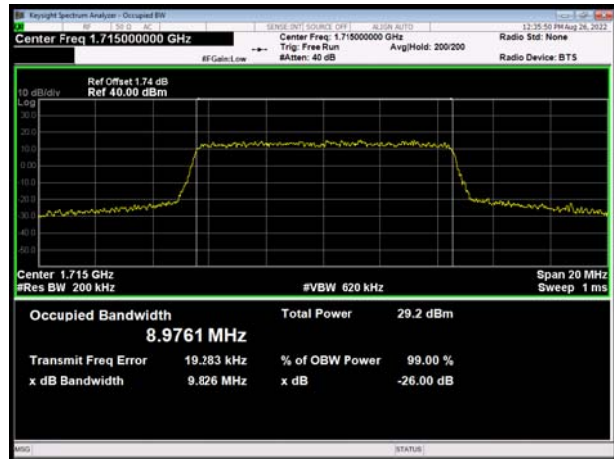

LTE Band 66 16QAM 5MHz CH-Middle

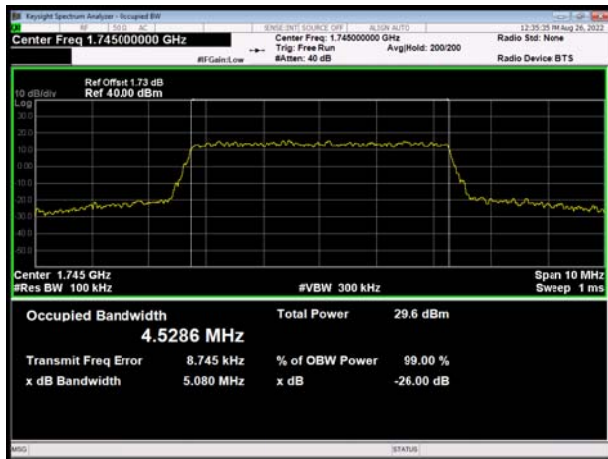

LTE Band 66 16QAM 10MHz CH-Middle

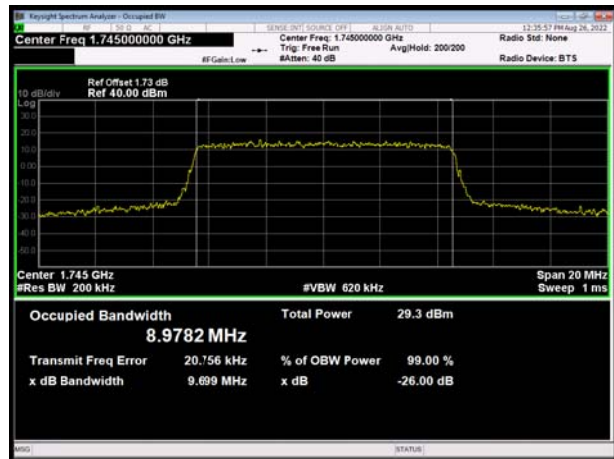

LTE Band 66 16QAM 5MHz CH-High

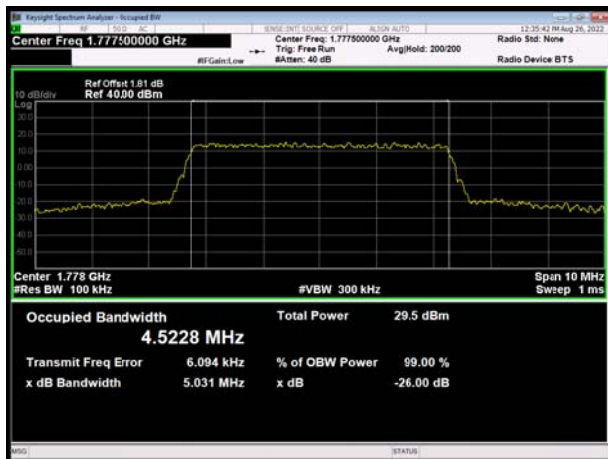

LTE Band 66 16QAM 10MHz CH-High

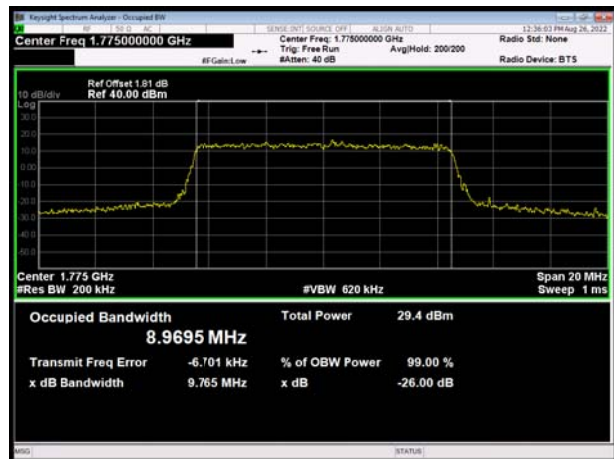



LTE Band 66 16QAM 15MHz CH-Low

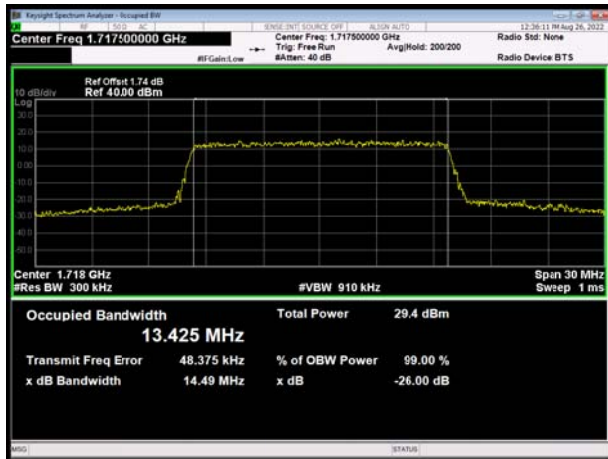

LTE Band 66 16QAM 20MHz CH-Low

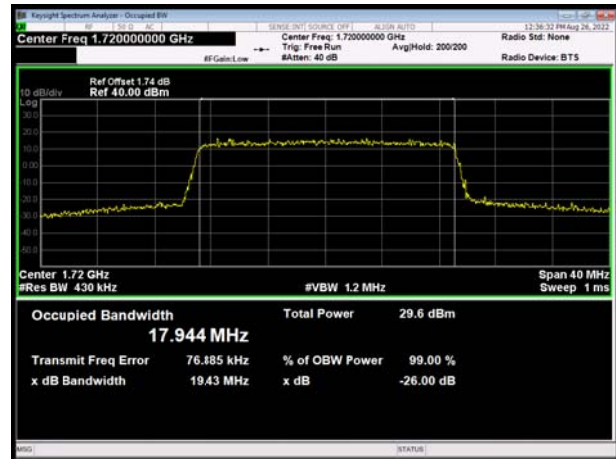

LTE Band 66 16QAM 15MHz CH-Middle

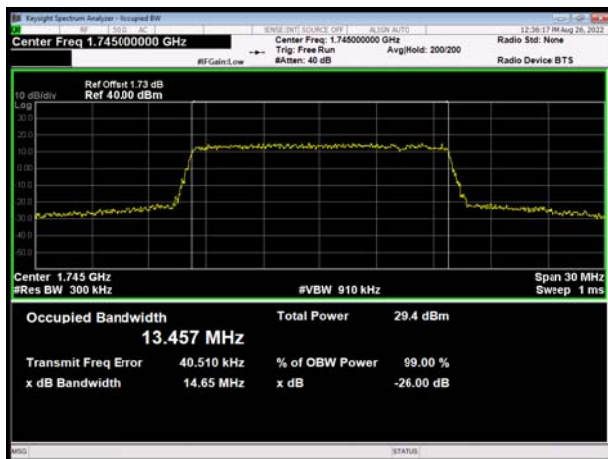

LTE Band 66 16QAM 20MHz CH-Middle

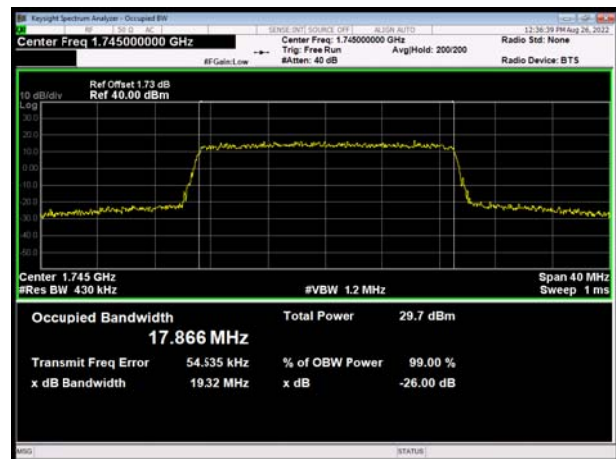

LTE Band 66 16QAM 15MHz CH-High

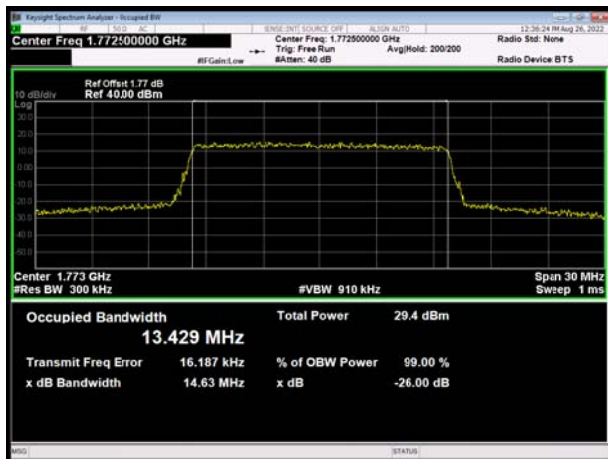

LTE Band 66 16QAM 20MHz CH-High

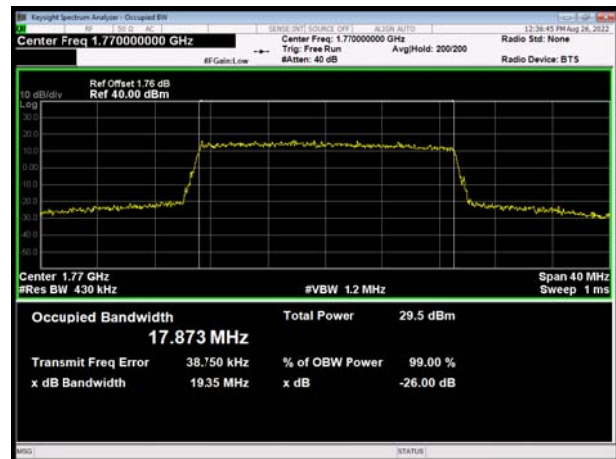

6.3 Band Edge

All the test traces in the plots shows the test results clearly.

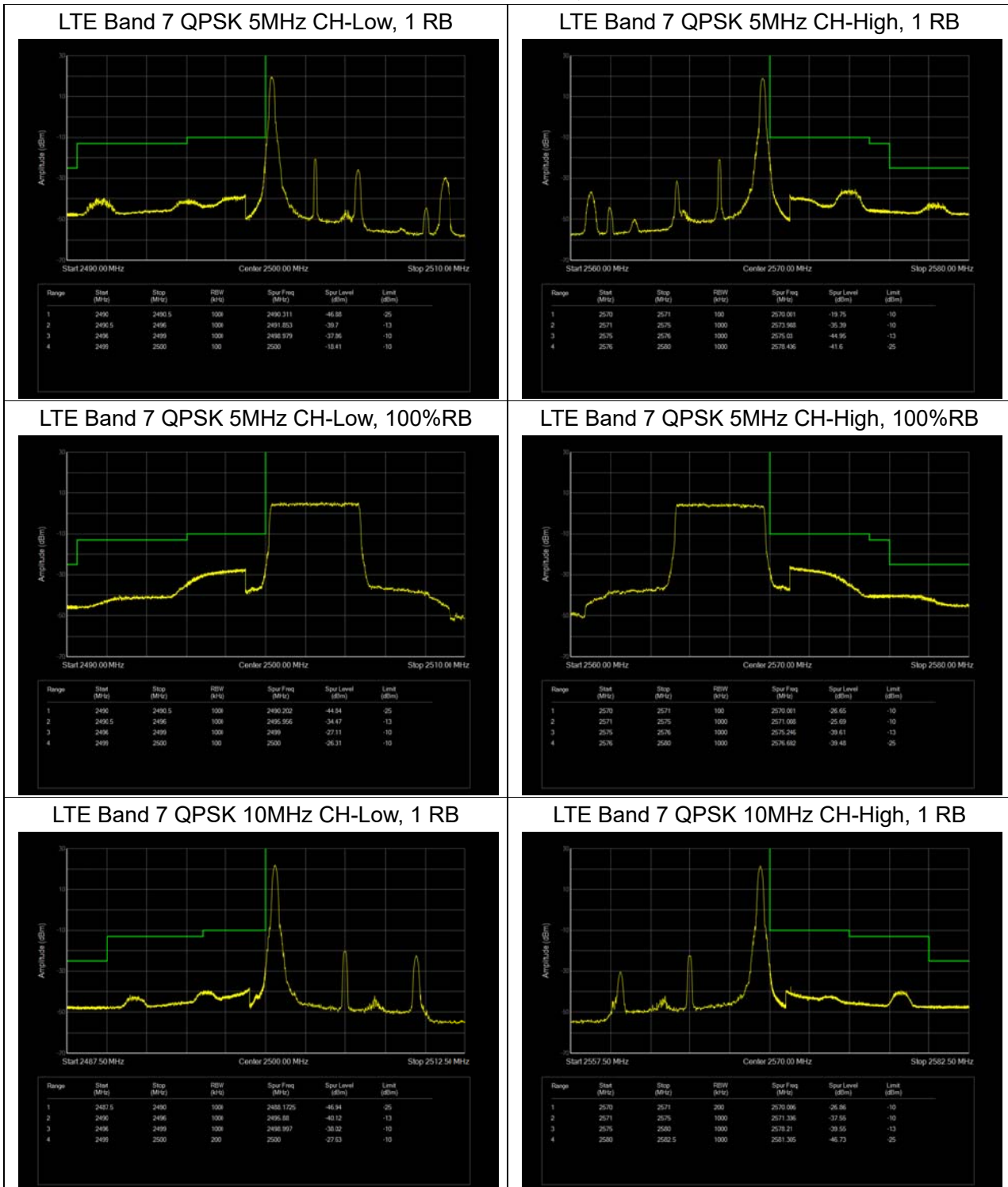



LTE Band 7 QPSK 10MHz CH-Low, 100%RB

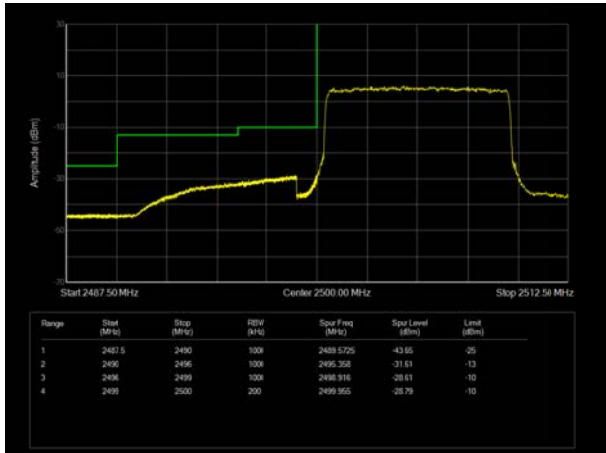

LTE Band 7 QPSK 10MHz CH-High, 100%RB

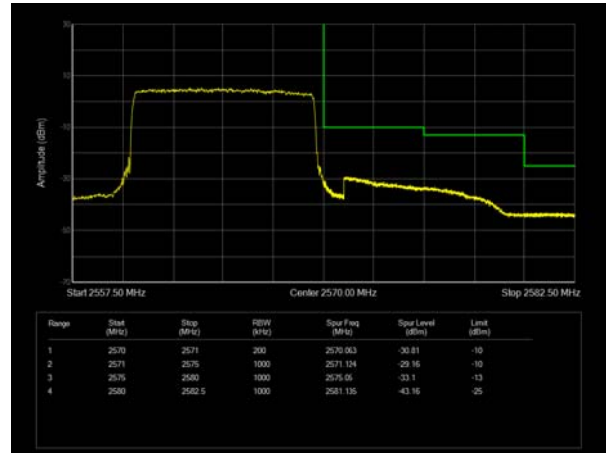

LTE Band 7 QPSK 15MHz CH-Low, 1 RB

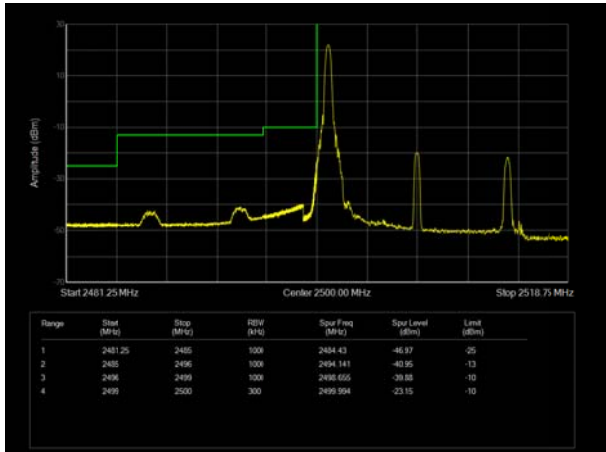

LTE Band 7 QPSK 15MHz CH-High, 1 RB

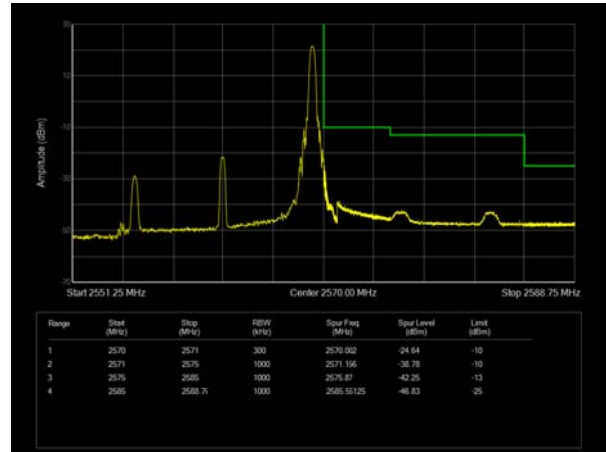

LTE Band 7 QPSK 15MHz CH-Low, 100%RB

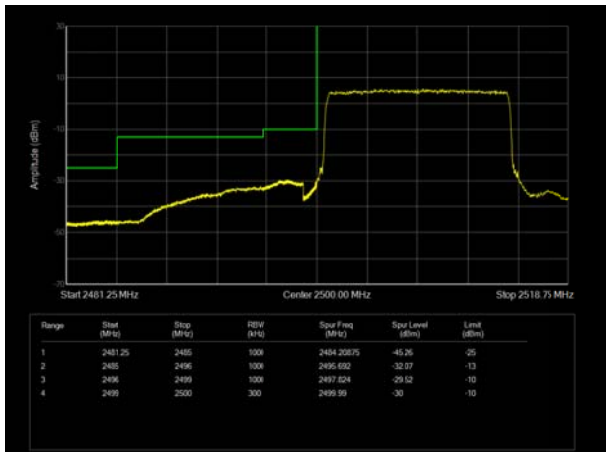

LTE Band 7 QPSK 15MHz CH-High, 100%RB

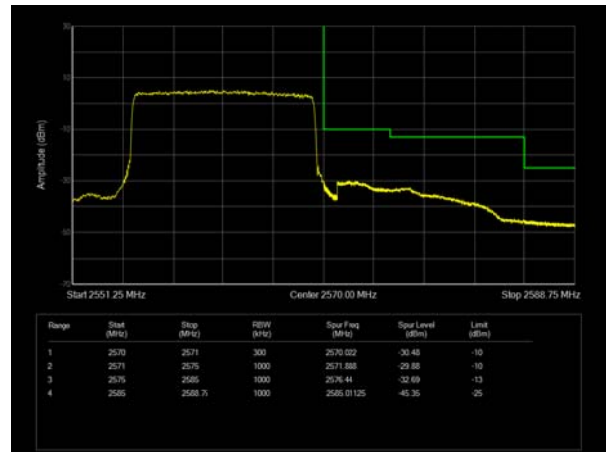

LTE Band 7 QPSK 20MHz CH-Low, 1 RB

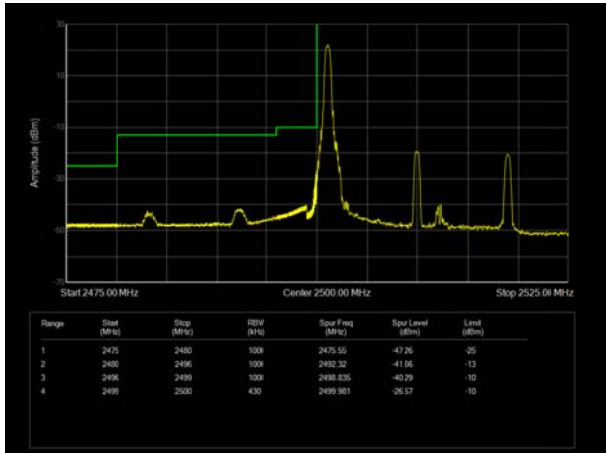

LTE Band 7 QPSK 20MHz CH-High, 1 RB

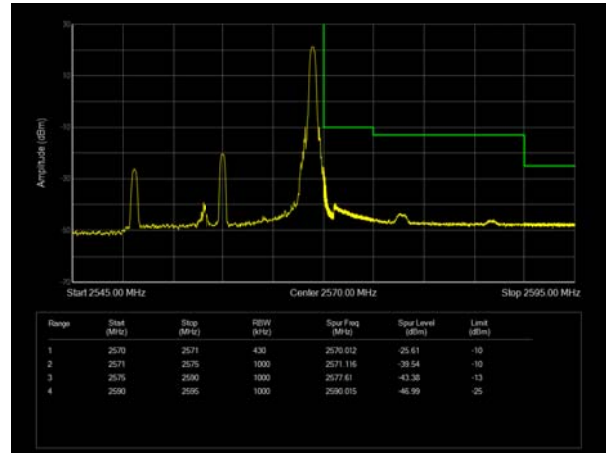

LTE Band 7 QPSK 20MHz CH-Low, 100%RB

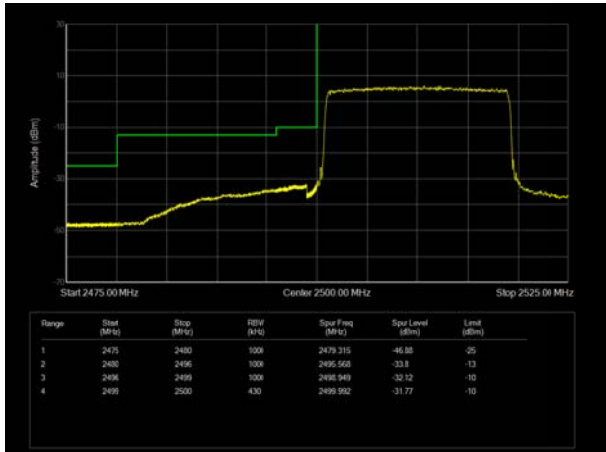

LTE Band 7 QPSK 20MHz CH-High, 100%RB

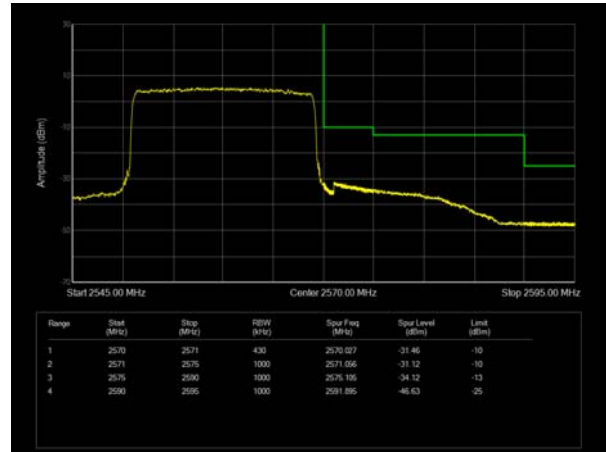

LTE Band 7 16QAM 5MHz CH-Low, 1 RB

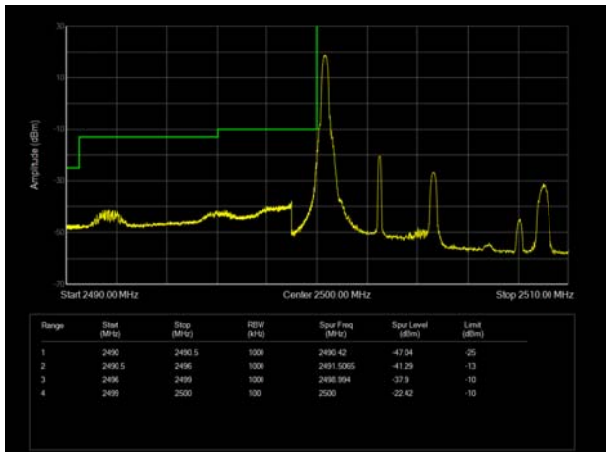

LTE Band 7 16QAM 5MHz CH-High, 1 RB

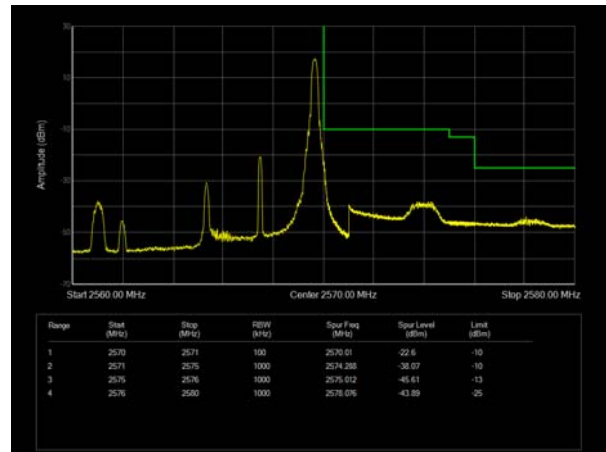



LTE Band 7 16QAM 5MHz CH-Low, 100%RB

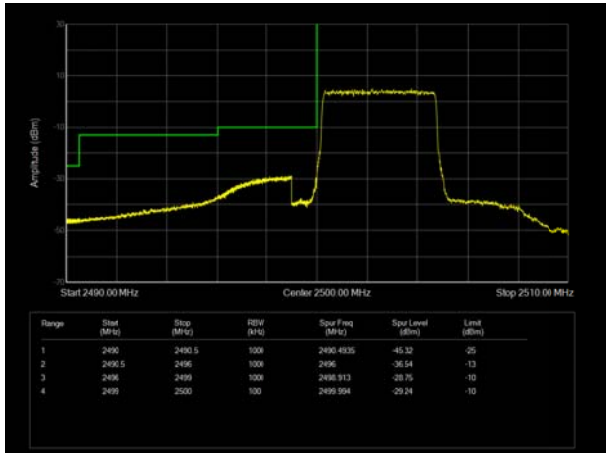

LTE Band 7 16QAM 5MHz CH-High, 100%RB

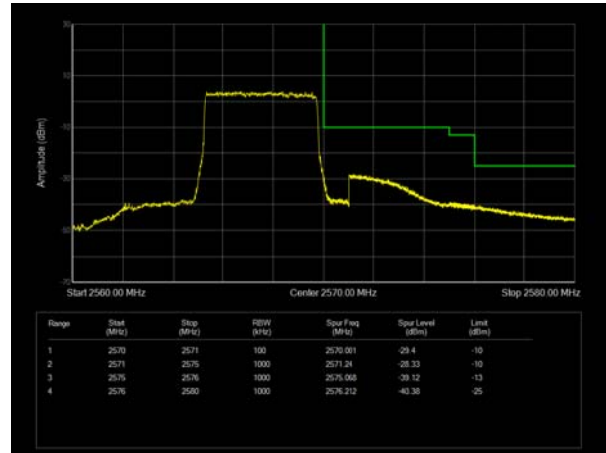

LTE Band 7 16QAM 10MHz CH-Low, 1 RB

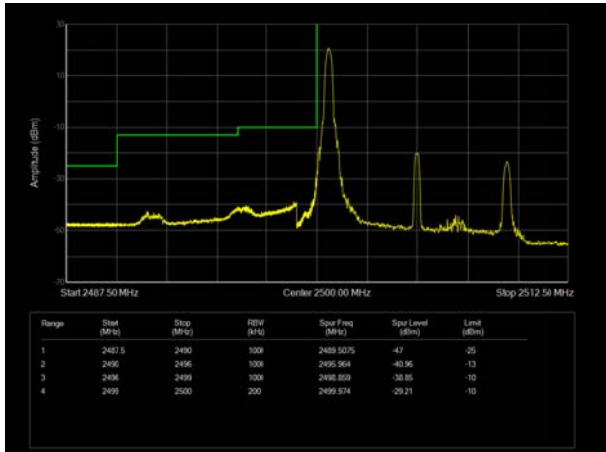

LTE Band 7 16QAM 10MHz CH-High, 1 RB

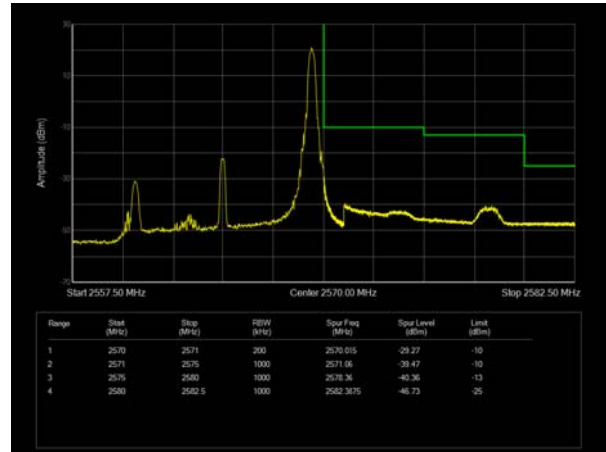

LTE Band 7 16QAM 10MHz CH-Low, 100%RB

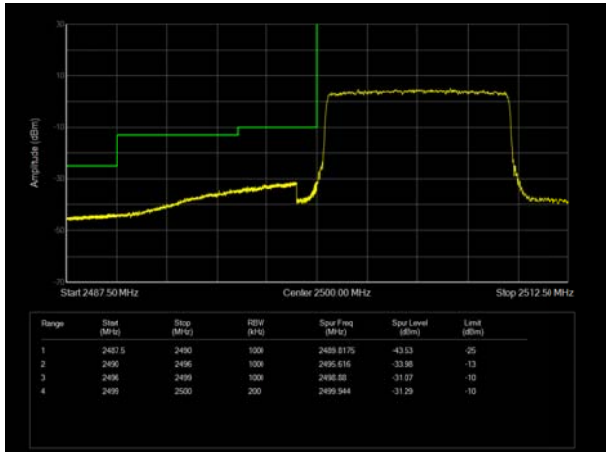

LTE Band 7 16QAM 10MHz CH-High, 100%RB

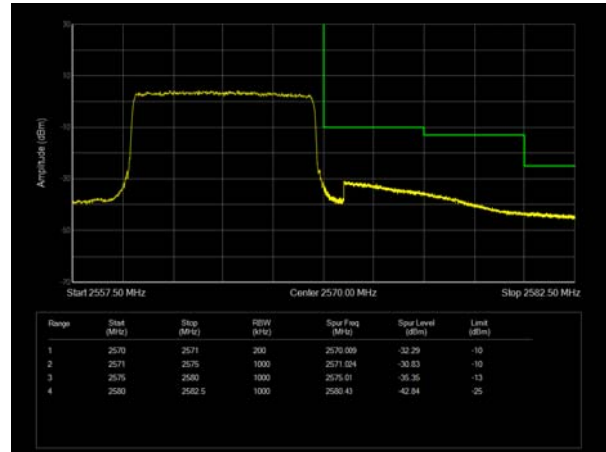



LTE Band 7 16QAM 15MHz CH-Low, 1 RB

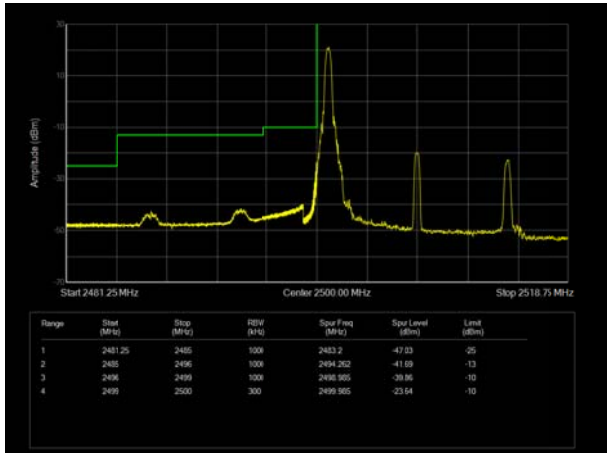

LTE Band 7 16QAM 15MHz CH-High, 1 RB

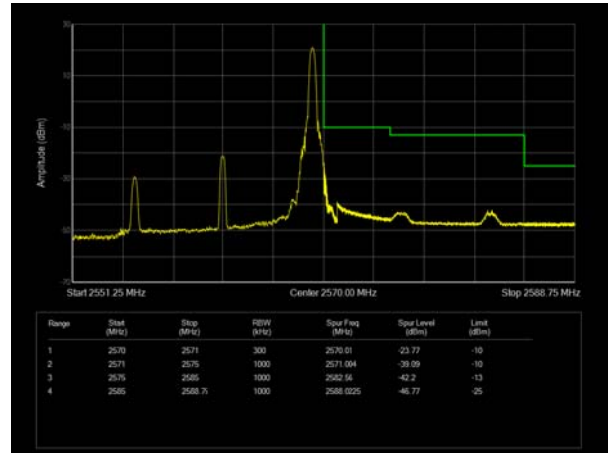

LTE Band 7 16QAM 15MHz CH-Low, 100%RB

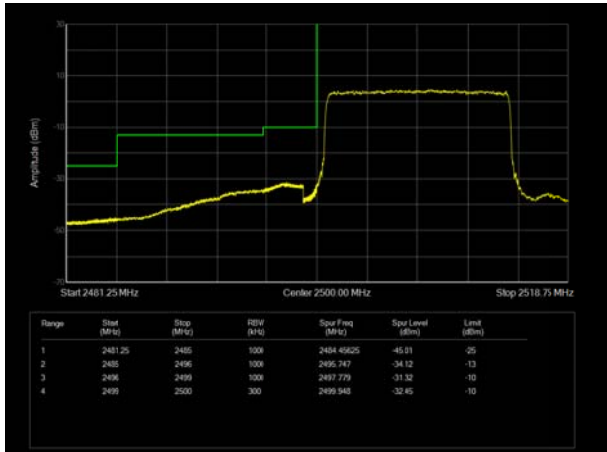

LTE Band 7 16QAM 15MHz CH-High, 100%RB

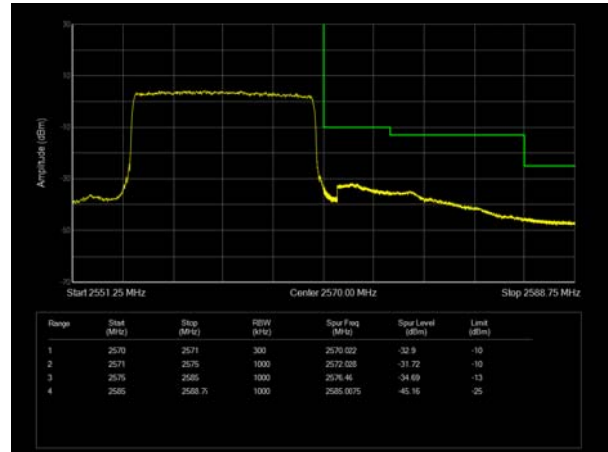

LTE Band 7 16QAM 20MHz CH-Low, 1 RB

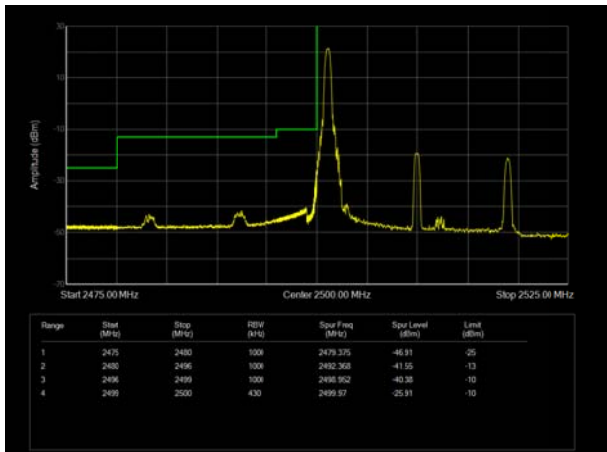

LTE Band 7 16QAM 20MHz CH-High, 1 RB

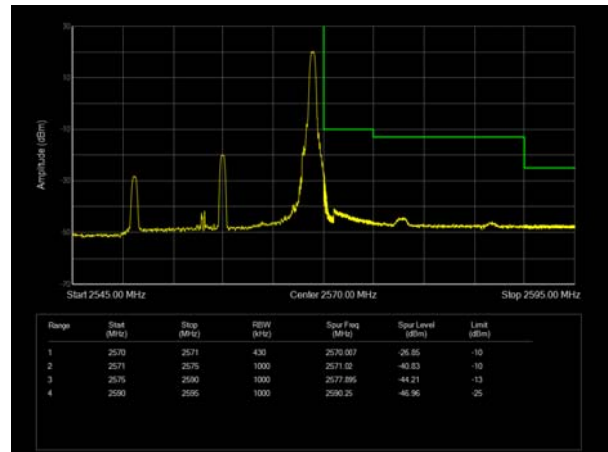



LTE Band 7 16QAM 20MHz CH-Low, 100%RB

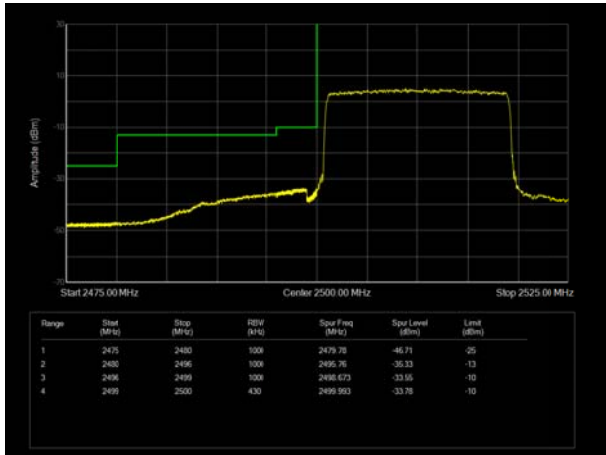

LTE Band 7 16QAM 20MHz CH-High, 100%RB

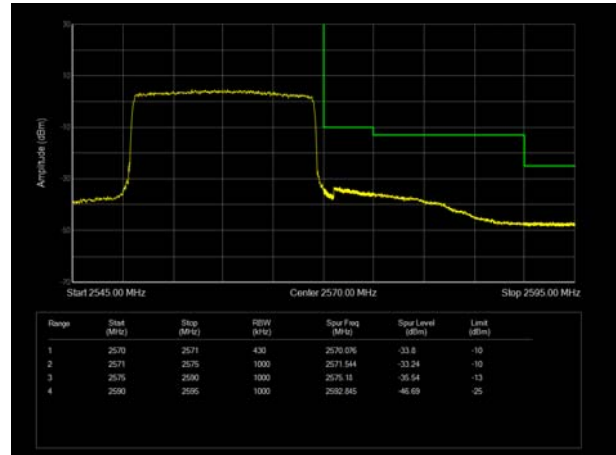



LTE Band 66 QPSK 1.4MHz CH-Low, 1 RB

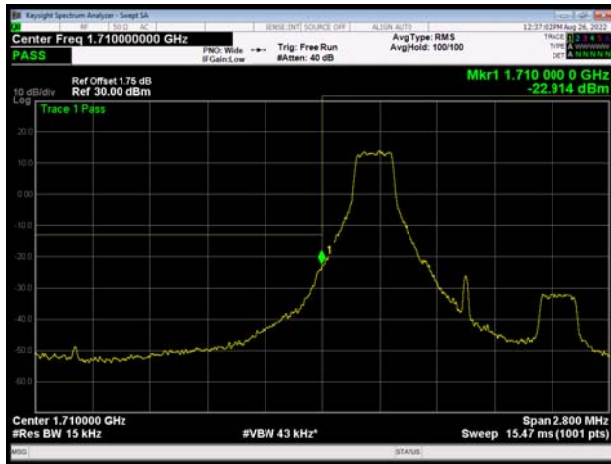

LTE Band 66 QPSK 1.4MHz CH-High, 1 RB



LTE Band 66 QPSK 1.4MHz CH-Low, 100%RB



LTE Band 66 QPSK 1.4MHz CH-High, 100%RB



LTE Band 66 QPSK 3MHz CH-Low, 1 RB

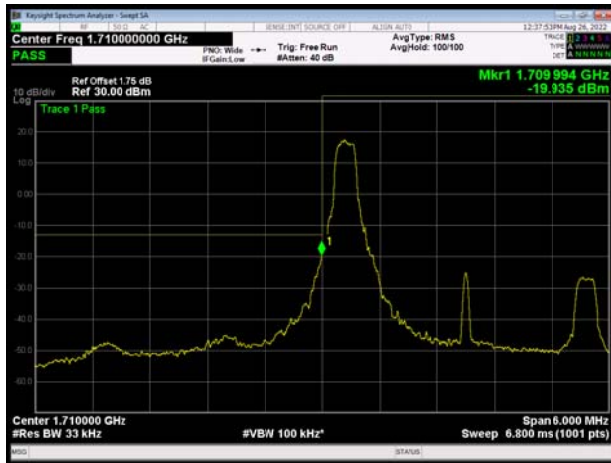

LTE Band 66 QPSK 3MHz CH-High, 1 RB

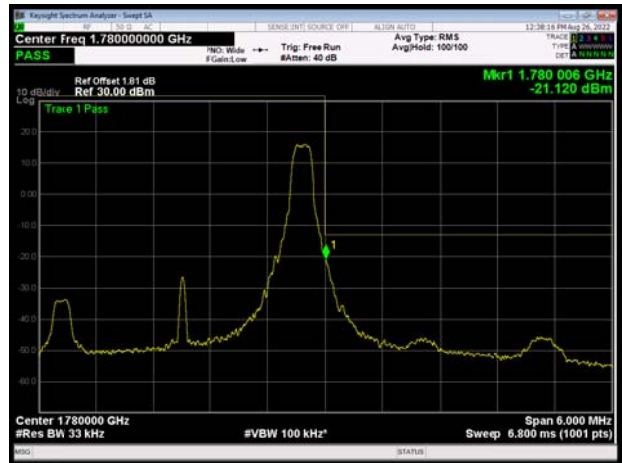



LTE Band 66 QPSK 3MHz CH-Low, 100%RB

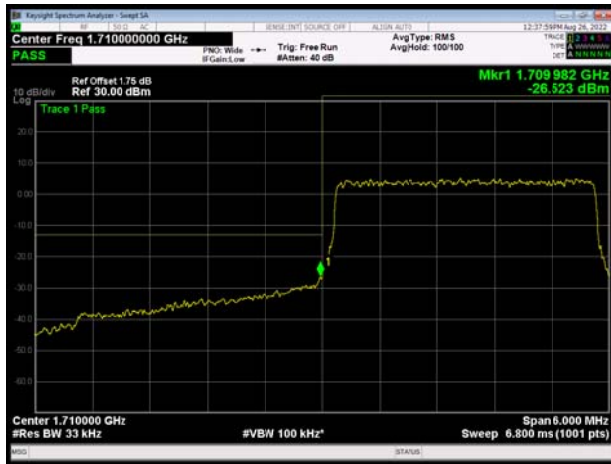

LTE Band 66 QPSK 3MHz CH-High, 100%RB



LTE Band 66 QPSK 5MHz CH-Low, 1 RB

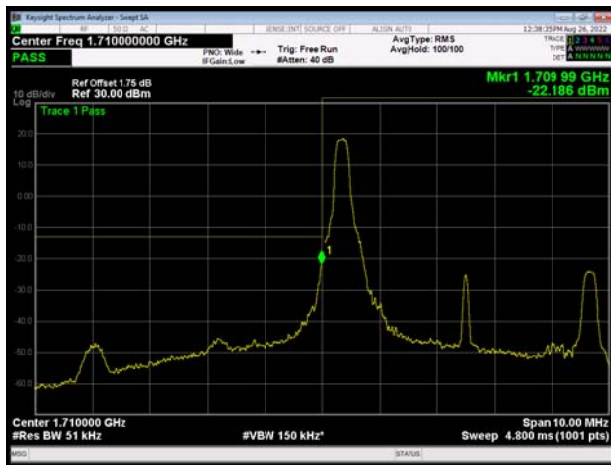

LTE Band 66 QPSK 5MHz CH-High, 1 RB

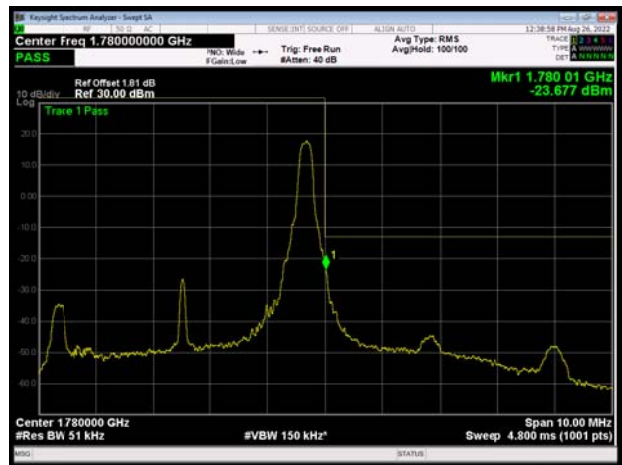

LTE Band 66 QPSK 5MHz CH-Low, 100%RB



LTE Band 66 QPSK 5MHz CH-High, 100%RB

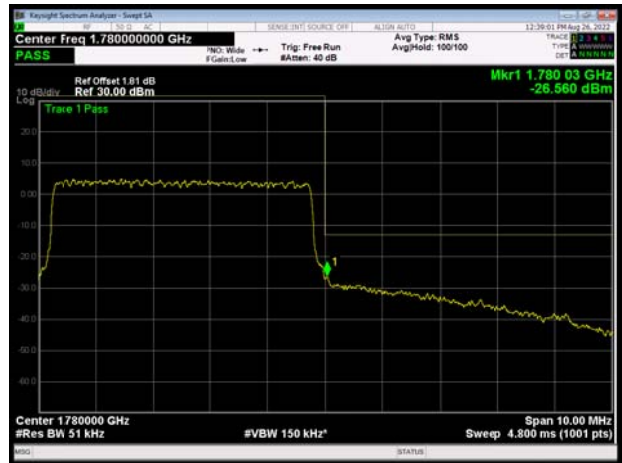



LTE Band 66 QPSK 10MHz CH-Low, 1 RB

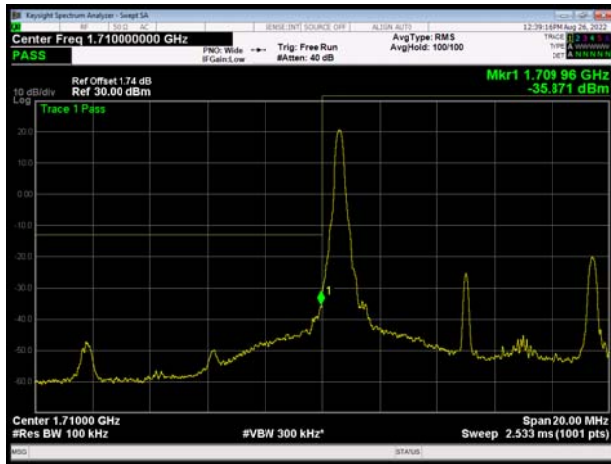

LTE Band 66 QPSK 10MHz CH-High, 1 RB

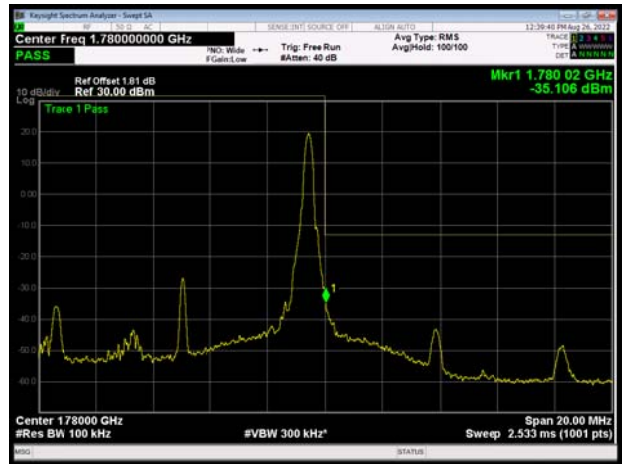

LTE Band 66 QPSK 10MHz CH-Low, 100%RB

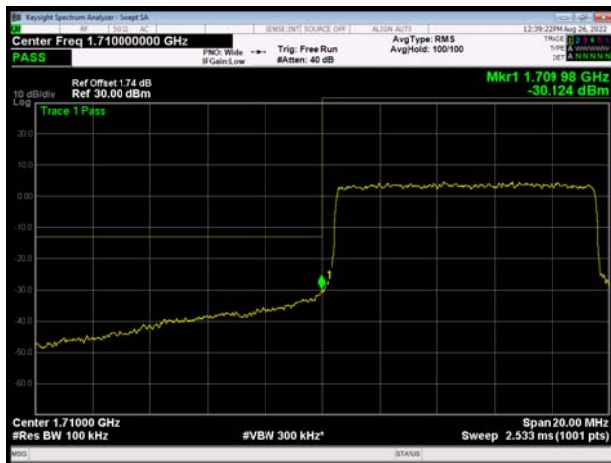

LTE Band 66 QPSK 10MHz CH-High, 100%RB



LTE Band 66 QPSK 15MHz CH-Low, 1 RB

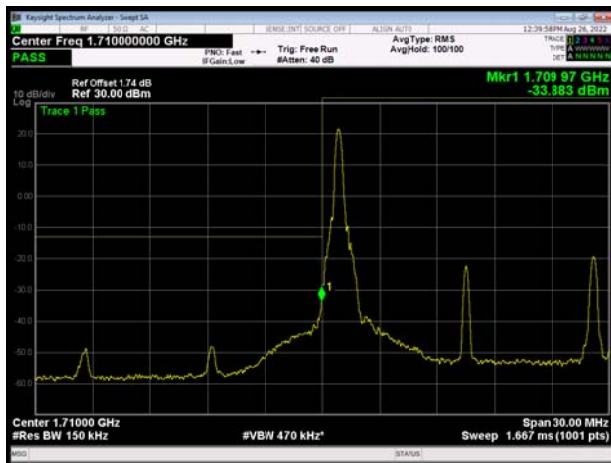

LTE Band 66 QPSK 15MHz CH-High, 1 RB

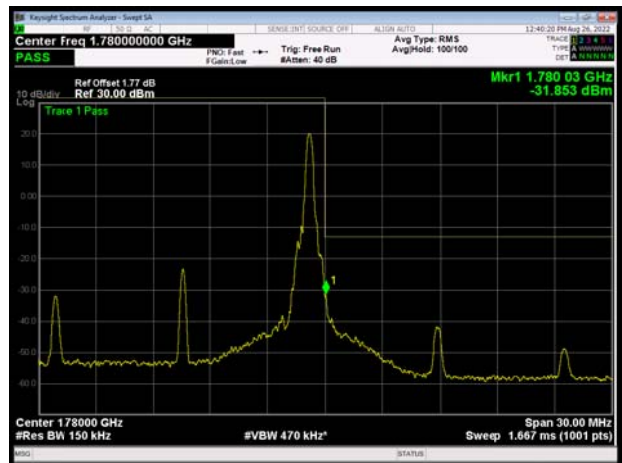



LTE Band 66 QPSK 15MHz CH-Low, 100%RB



LTE Band 66 QPSK 15MHz CH-High, 100%RB



LTE Band 66 QPSK 20MHz CH-Low, 1 RB

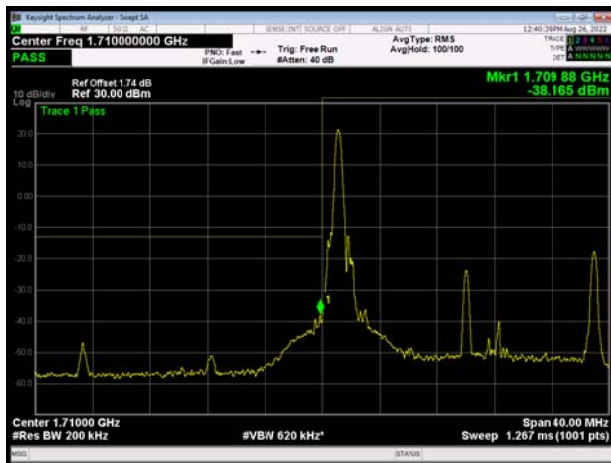

LTE Band 66 QPSK 20MHz CH-High, 1 RB

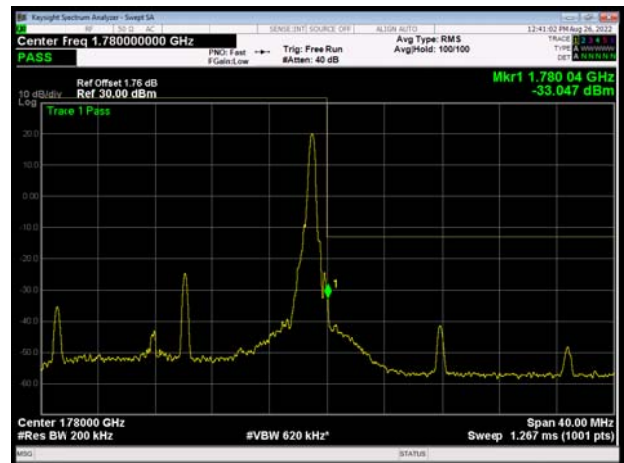

LTE Band 66 QPSK 20MHz CH-Low, 100%RB



LTE Band 66 QPSK 20MHz CH-High, 100%RB

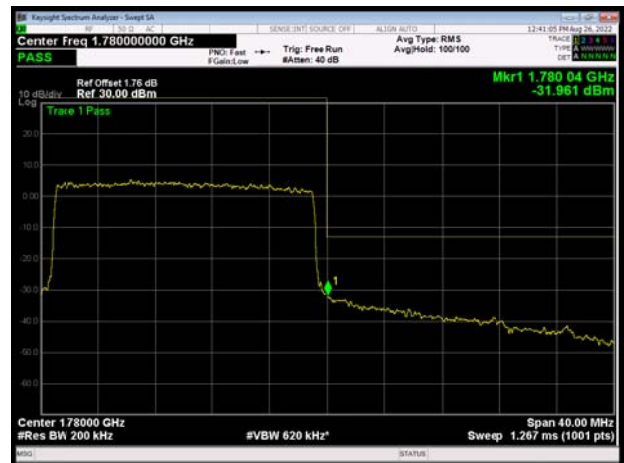



LTE Band 66 16QAM 1.4MHz CH-Low, 1 RB

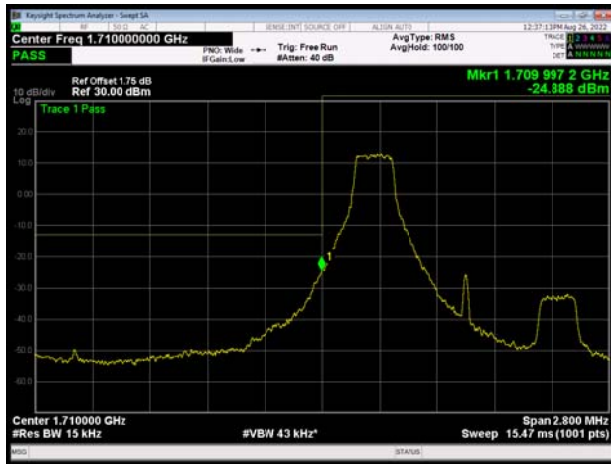

LTE Band 66 16QAM 1.4MHz CH-High, 1 RB

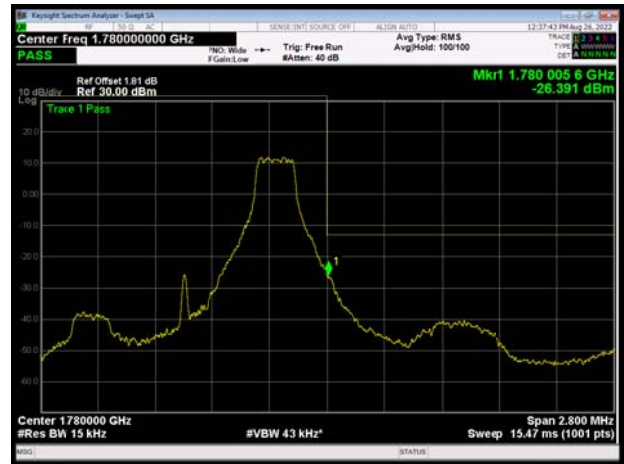

LTE Band 66 16QAM 1.4MHz CH-Low, 100%RB



LTE Band 66 16QAM 1.4MHz CH-High, 100%RB



LTE Band 66 16QAM 3MHz CH-Low, 1 RB

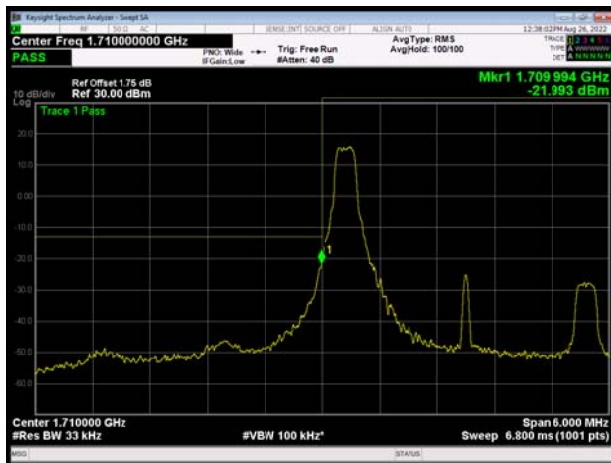

LTE Band 66 16QAM 3MHz CH-High, 1 RB

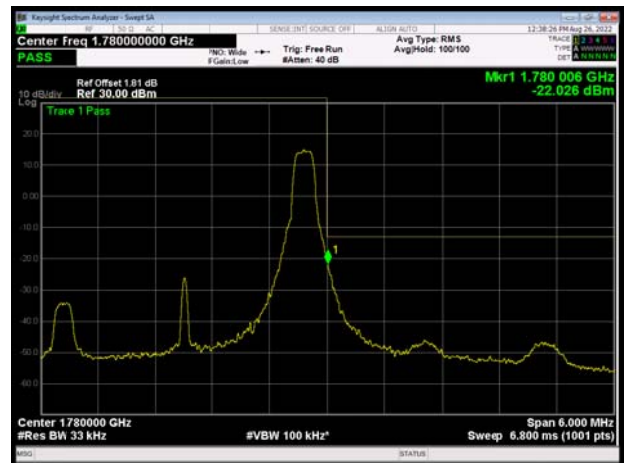



LTE Band 66 16QAM 3MHz CH-Low, 100%RB

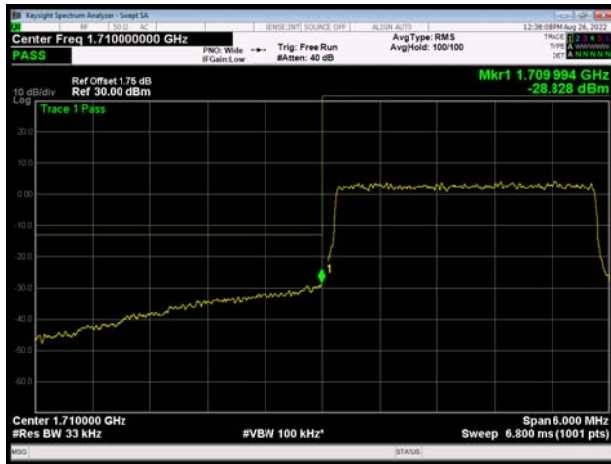

LTE Band 66 16QAM 3MHz CH-High, 100%RB

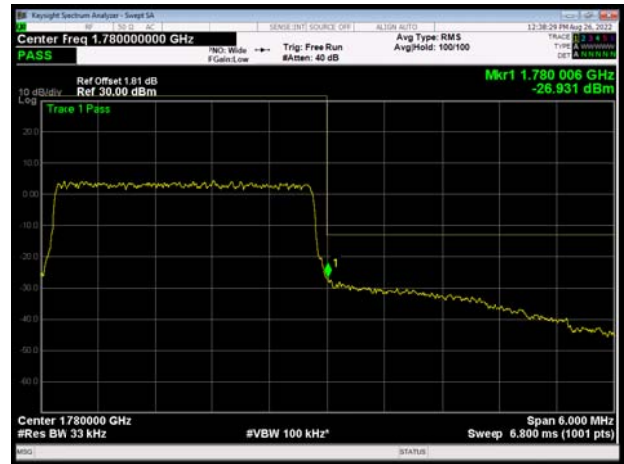

LTE Band 66 16QAM 5MHz CH-Low, 1 RB

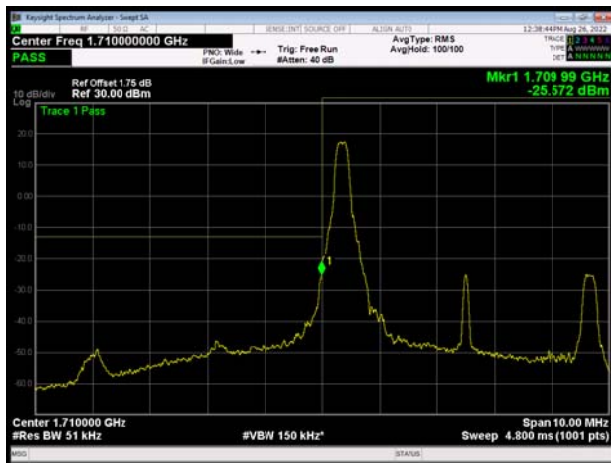

LTE Band 66 16QAM 5MHz CH-High, 1 RB

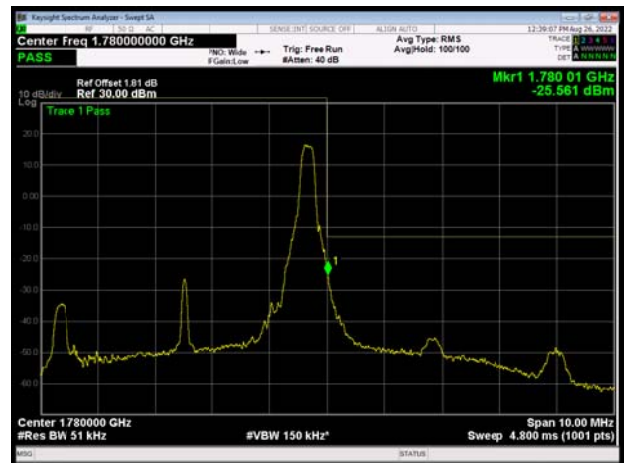

LTE Band 66 16QAM 5MHz CH-Low, 100%RB

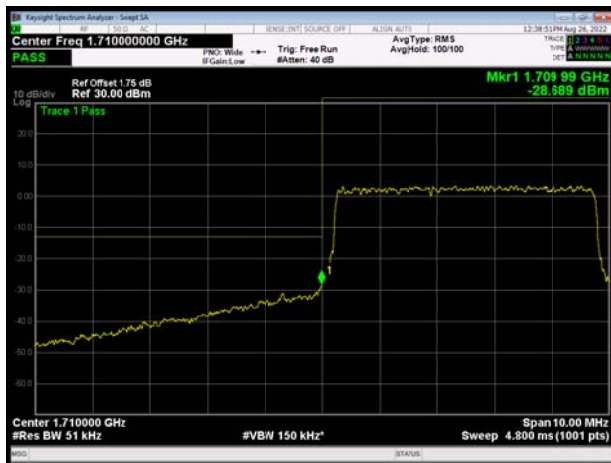

LTE Band 66 16QAM 5MHz CH-High, 100%RB





LTE Band 66 16QAM 10MHz CH-Low, 1 RB

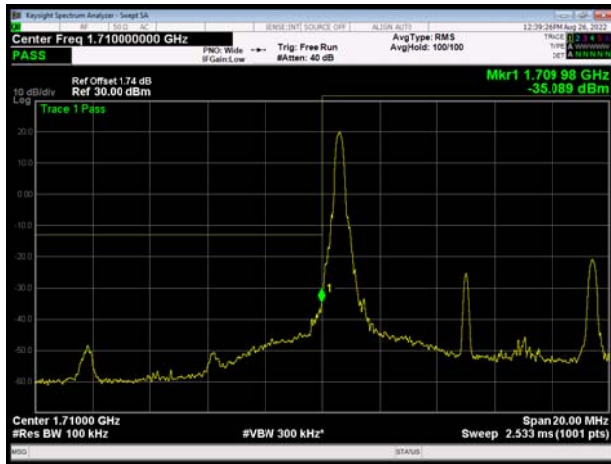

LTE Band 66 16QAM 10MHz CH-High, 1 RB

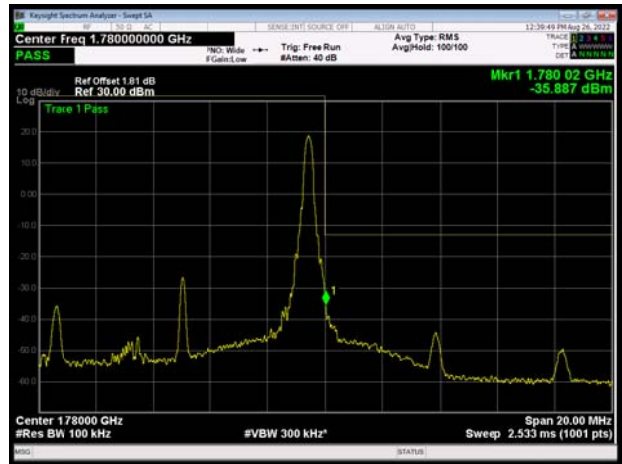

LTE Band 66 16QAM 10MHz CH-Low, 100%RB



LTE Band 66 16QAM 10MHz CH-High, 100%RB

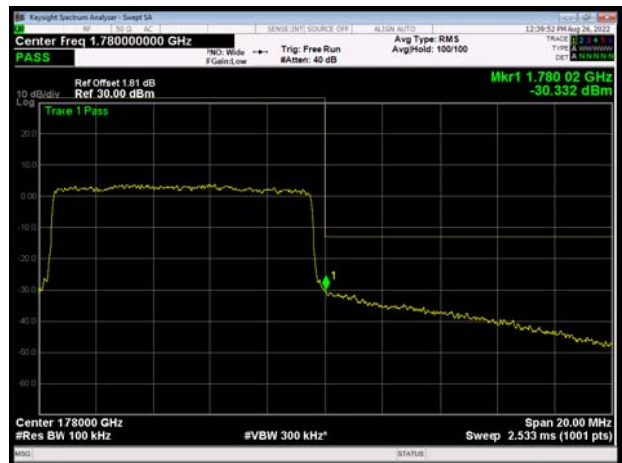

LTE Band 66 16QAM 15MHz CH-Low, 1 RB

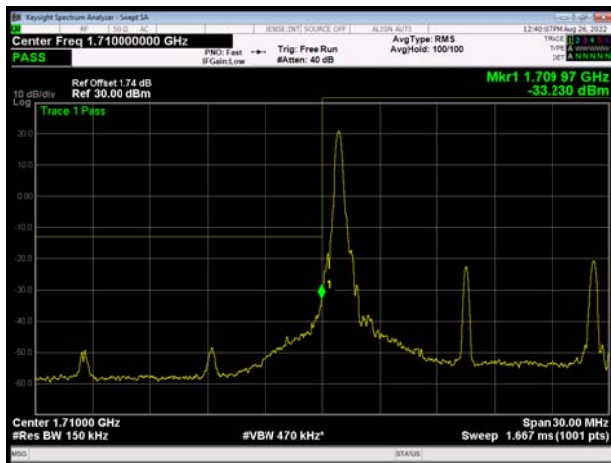

LTE Band 66 16QAM 15MHz CH-High, 1 RB

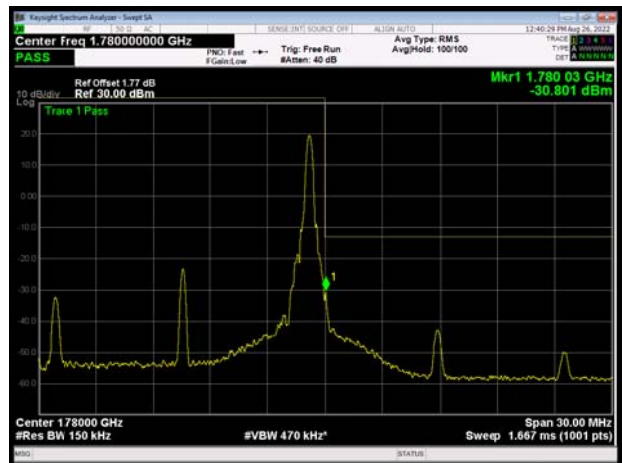



LTE Band 66 16QAM 15MHz CH-Low, 100%RB



LTE Band 66 16QAM 15MHz CH-High, 100%RB



LTE Band 66 16QAM 20MHz CH-Low, 1 RB

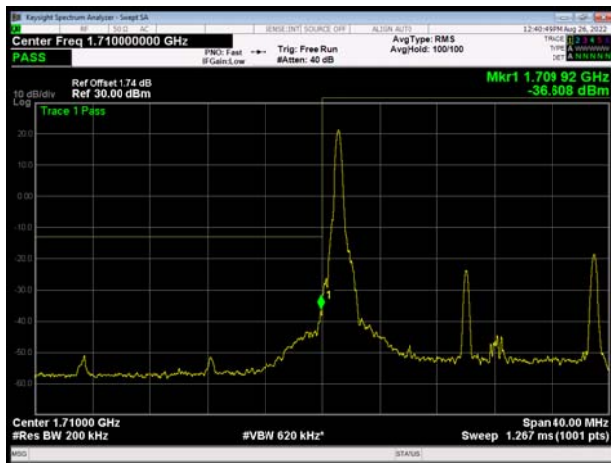

LTE Band 66 16QAM 20MHz CH-High, 1 RB

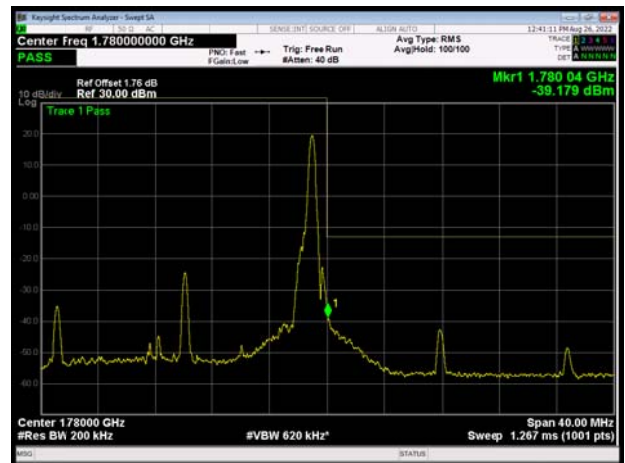

LTE Band 66 16QAM 20MHz CH-Low, 100%RB



LTE Band 66 16QAM 20MHz CH-High, 100%RB

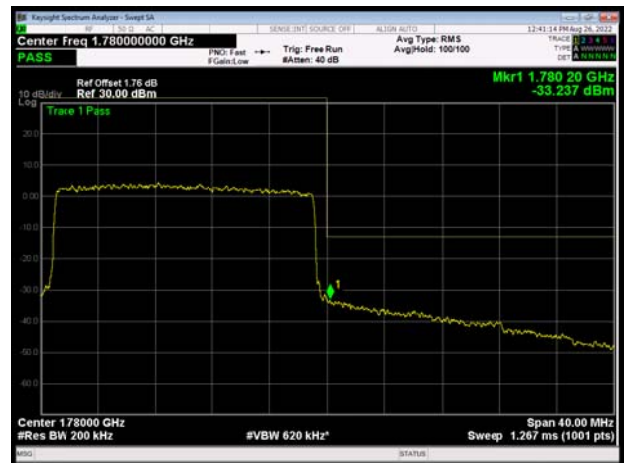

6.4 Peak-to-Average Power Ratio (PAPR)

LTE Band 7								
Modulation	Bandwidth (MHz)	Channel	Frequency (MHz)	Peak (dBm)	Avg (dBm)	PAPR (dB)	Limit (dB)	Conclusion
QPSK	5	20775	2502.5	25.84	21.04	4.80	≤13	PASS
		21100	2535	25.09	20.39	4.70	≤13	PASS
		21425	2567.5	25.26	20.39	4.87	≤13	PASS
	10	20800	2505	26.01	21.22	4.79	≤13	PASS
		21100	2535	25.13	20.45	4.68	≤13	PASS
		21400	2565	25.28	20.44	4.84	≤13	PASS
	15	20825	2507.5	26.16	21.11	5.05	≤13	PASS
		21100	2535	25.40	20.46	4.94	≤13	PASS
		21375	2562.5	25.48	20.43	5.05	≤13	PASS
	20	20850	2510	25.96	21.06	4.90	≤13	PASS
		21100	2535	25.40	20.59	4.81	≤13	PASS
		21350	2560	25.34	20.40	4.94	≤13	PASS
16QAM	5	20775	2502.5	25.75	20.09	5.66	≤13	PASS
		21100	2535	25.08	19.62	5.46	≤13	PASS
		21425	2567.5	25.12	19.43	5.69	≤13	PASS
	10	20800	2505	25.77	20.11	5.66	≤13	PASS
		21100	2535	24.93	19.37	5.56	≤13	PASS
		21400	2565	25.00	19.30	5.70	≤13	PASS
	15	20825	2507.5	25.98	20.19	5.79	≤13	PASS
		21100	2535	25.18	19.50	5.68	≤13	PASS
		21375	2562.5	25.26	19.48	5.78	≤13	PASS
	20	20850	2510	25.76	20.02	5.74	≤13	PASS
		21100	2535	25.25	19.63	5.62	≤13	PASS
		21350	2560	25.30	19.54	5.76	≤13	PASS



LTE Band 66								
Modulation	Bandwidth (MHz)	Channel	Frequency (MHz)	Peak (dBm)	Avg (dBm)	PAPR (dB)	Limit (dB)	Conclusion
QPSK	1.4	131979	1710.7	27.69	22.59	5.10	≤13	PASS
		132322	1745	27.83	22.51	5.32	≤13	PASS
		132665	1779.3	27.60	22.51	5.09	≤13	PASS
	3	131987	1711.5	27.70	22.51	5.19	≤13	PASS
		132322	1745	27.91	22.53	5.38	≤13	PASS
		132657	1778.5	27.65	22.45	5.20	≤13	PASS
	5	131997	1712.5	27.64	22.47	5.17	≤13	PASS
		132322	1745	27.87	22.52	5.35	≤13	PASS
		132647	1777.5	27.64	22.44	5.20	≤13	PASS
	10	132022	1715	27.62	22.41	5.21	≤13	PASS
		132322	1745	27.95	22.66	5.29	≤13	PASS
		132622	1775	27.68	22.45	5.23	≤13	PASS
	15	132047	1717.5	27.84	22.48	5.36	≤13	PASS
		132322	1745	27.94	22.51	5.43	≤13	PASS
		132597	1772.5	27.83	22.43	5.40	≤13	PASS
	20	132072	1720	27.68	22.49	5.19	≤13	PASS
		132322	1745	27.77	22.52	5.25	≤13	PASS
		132572	1770	27.63	22.43	5.20	≤13	PASS
16QAM	1.4	131979	1710.7	27.73	21.78	5.95	≤13	PASS
		132322	1745	27.82	21.60	6.22	≤13	PASS
		132665	1779.3	27.58	21.51	6.07	≤13	PASS
	3	131987	1711.5	27.63	21.50	6.13	≤13	PASS
		132322	1745	27.83	21.52	6.31	≤13	PASS
		132657	1778.5	27.61	21.44	6.17	≤13	PASS
	5	131997	1712.5	27.54	21.44	6.10	≤13	PASS
		132322	1745	27.82	21.61	6.21	≤13	PASS
		132647	1777.5	27.75	21.69	6.06	≤13	PASS
	10	132022	1715	27.57	21.46	6.11	≤13	PASS
		132322	1745	27.79	21.64	6.15	≤13	PASS
		132622	1775	27.57	21.43	6.14	≤13	PASS
	15	132047	1717.5	27.78	21.64	6.14	≤13	PASS
		132322	1745	27.82	21.57	6.25	≤13	PASS
		132597	1772.5	27.69	21.51	6.18	≤13	PASS
	20	132072	1720	27.64	21.55	6.09	≤13	PASS
		132322	1745	27.73	21.61	6.12	≤13	PASS
		132572	1770	27.55	21.45	6.10	≤13	PASS

6.5 Frequency Stability

LTE Band 7						
Condition		Freq.Error (Hz)	Freq.Error (Hz)	Frequency Stability (ppm)	Frequency Stability (ppm)	Verdict
BANDWIDTH	5MHz					
Temperature	Voltage	16QAM	QPSK	16QAM	QPSK	
Normal (25°C)	Normal	2.75	2.78	0.00108	0.00109	PASS
Extreme (90°C)		7.50	5.83	0.00296	0.00230	PASS
Extreme (80°C)		13.29	1.94	0.00524	0.00077	PASS
Extreme (70°C)		2.72	17.55	0.00107	0.00692	PASS
Extreme (60°C)		10.36	11.73	0.00409	0.00463	PASS
Extreme (50°C)		15.64	4.34	0.00617	0.00171	PASS
Extreme (40°C)		13.03	4.27	0.00514	0.00168	PASS
Extreme (30°C)		1.22	13.51	0.00048	0.00533	PASS
Extreme (20°C)		8.28	6.49	0.00327	0.00256	PASS
Extreme (10°C)		7.34	7.61	0.00290	0.00300	PASS
Extreme (0°C)		7.89	12.35	0.00311	0.00487	PASS
Extreme (-10°C)		14.27	5.56	0.00563	0.00219	PASS
Extreme (-20°C)		15.97	16.37	0.00630	0.00646	PASS
Extreme (-30°C)		4.37	2.31	0.00172	0.00091	PASS
Extreme (-40°C)		2.53	7.17	0.00100	0.00283	PASS
25°C	LV	15.66	6.29	0.00618	0.00248	PASS
	HV	15.05	16.60	0.00594	0.00655	PASS
Condition		Freq.Error (Hz)	Freq.Error (Hz)	Frequency Stability (ppm)	Frequency Stability (ppm)	Verdict
BANDWIDTH	10MHz					
Temperature	Voltage	16QAM	QPSK	16QAM	QPSK	
Normal (25°C)	Normal	3.13	13.52	0.00124	0.00533	PASS
Extreme (90°C)		1.64	3.10	0.00065	0.00122	PASS
Extreme (80°C)		10.45	2.84	0.00412	0.00112	PASS
Extreme (70°C)		2.31	17.74	0.00091	0.00700	PASS
Extreme (60°C)		4.47	10.47	0.00176	0.00413	PASS
Extreme (50°C)		7.89	10.38	0.00311	0.00410	PASS
Extreme (40°C)		14.25	12.34	0.00562	0.00487	PASS
Extreme (30°C)		14.45	6.06	0.00570	0.00239	PASS
Extreme (20°C)		8.32	8.45	0.00328	0.00333	PASS
Extreme (10°C)		4.07	7.46	0.00161	0.00294	PASS
Extreme (0°C)		13.83	8.14	0.00546	0.00321	PASS
Extreme (-10°C)		6.32	5.37	0.00249	0.00212	PASS
Extreme (-20°C)		12.06	6.50	0.00476	0.00256	PASS



Extreme (-30°C)		6.39	4.67	0.00252	0.00184	PASS
Extreme (-40°C)		12.98	10.82	0.00512	0.00427	PASS
25°C	LV	11.60	16.44	0.00458	0.00648	PASS
	HV	11.95	7.45	0.00472	0.00294	PASS
Condition		Freq.Error (Hz)	Freq.Error (Hz)	Frequency Stability (ppm)	Frequency Stability (ppm)	Verdict
BANDWIDTH	15MHz					
Temperature	Voltage	16QAM	QPSK	16QAM	QPSK	
Normal (25°C)	Normal	10.97	11.87	0.00433	0.00468	PASS
Extreme (90°C)		6.05	10.35	0.00239	0.00408	PASS
Extreme (80°C)		6.61	14.70	0.00261	0.00580	PASS
Extreme (70°C)		7.03	9.50	0.00277	0.00375	PASS
Extreme (60°C)		1.52	15.76	0.00060	0.00622	PASS
Extreme (50°C)		1.31	6.71	0.00052	0.00265	PASS
Extreme (40°C)		12.06	13.24	0.00476	0.00522	PASS
Extreme (30°C)		1.26	6.96	0.00050	0.00274	PASS
Extreme (20°C)		1.35	7.62	0.00053	0.00300	PASS
Extreme (10°C)		1.03	3.86	0.00041	0.00152	PASS
Extreme (0°C)		1.57	4.12	0.00062	0.00162	PASS
Extreme (-10°C)		15.21	4.03	0.00600	0.00159	PASS
Extreme (-20°C)		14.90	7.29	0.00588	0.00287	PASS
Extreme (-30°C)		2.87	5.37	0.00113	0.00212	PASS
Extreme (-40°C)		5.24	2.10	0.00207	0.00083	PASS
25°C	LV	3.20	17.36	0.00126	0.00685	PASS
	HV	4.90	10.02	0.00193	0.00395	PASS
Condition		Freq.Error (Hz)	Freq.Error (Hz)	Frequency Stability (ppm)	Frequency Stability (ppm)	Verdict
BANDWIDTH	20MHz					
Temperature	Voltage	16QAM	QPSK	16QAM	QPSK	
Normal (25°C)	Normal	16.06	12.40	0.00633	0.00489	PASS
Extreme (90°C)		13.42	8.78	0.00529	0.00346	PASS
Extreme (80°C)		6.39	4.46	0.00252	0.00176	PASS
Extreme (70°C)		16.49	17.94	0.00651	0.00708	PASS
Extreme (60°C)		17.58	10.31	0.00693	0.00407	PASS
Extreme (50°C)		14.69	9.02	0.00579	0.00356	PASS
Extreme (40°C)		9.73	12.91	0.00384	0.00509	PASS
Extreme (30°C)		1.92	4.44	0.00076	0.00175	PASS
Extreme (20°C)		13.63	16.78	0.00538	0.00662	PASS
Extreme (10°C)		10.53	16.70	0.00415	0.00659	PASS
Extreme (0°C)		14.38	9.18	0.00567	0.00362	PASS
Extreme (-10°C)		10.78	10.22	0.00425	0.00403	PASS



Extreme (-20°C)		10.02	3.21	0.00395	0.00127	PASS
Extreme (-30°C)		16.31	8.70	0.00643	0.00343	PASS
Extreme (-40°C)		11.82	12.31	0.00466	0.00486	PASS
25°C	LV	3.12	5.38	0.00123	0.00212	PASS
	HV	2.93	4.16	0.00116	0.00164	PASS

LTE Band 66						
Condition		Freq.Error (Hz)	Freq.Error (Hz)	Frequency Stability (ppm)	Frequency Stability (ppm)	Verdict
BANDWIDTH	1.4MHz					
Temperature	Voltage	16QAM	QPSK	16QAM	QPSK	
Normal (25°C)	Normal	13.09	13.06	0.00750	0.00749	PASS
Extreme (90°C)		14.43	4.24	0.00827	0.00243	PASS
Extreme (80°C)		4.87	17.17	0.00279	0.00984	PASS
Extreme (70°C)		14.94	1.56	0.00856	0.00090	PASS
Extreme (60°C)		14.68	11.97	0.00841	0.00686	PASS
Extreme (50°C)		6.30	9.29	0.00361	0.00532	PASS
Extreme (40°C)		17.15	5.89	0.00983	0.00337	PASS
Extreme (30°C)		9.30	4.35	0.00533	0.00249	PASS
Extreme (20°C)		16.29	5.29	0.00933	0.00303	PASS
Extreme (10°C)		3.42	8.12	0.00196	0.00465	PASS
Extreme (0°C)		7.92	15.88	0.00454	0.00910	PASS
Extreme (-10°C)		10.00	2.36	0.00573	0.00135	PASS
Extreme (-20°C)		9.07	3.36	0.00520	0.00192	PASS
Extreme (-30°C)		7.72	1.51	0.00442	0.00087	PASS
Extreme (-40°C)		12.14	9.28	0.00696	0.00532	PASS
25°C		LV	2.84	3.31	0.00163	0.00190
	HV	3.89	3.16	0.00223	0.00181	PASS
Condition		Freq.Error (Hz)	Freq.Error (Hz)	Frequency Stability (ppm)	Frequency Stability (ppm)	Verdict
BANDWIDTH	3MHz					
Temperature	Voltage	16QAM	QPSK	16QAM	QPSK	
Normal (25°C)	Normal	7.08	17.78	0.00406	0.01019	PASS
Extreme (90°C)		5.90	12.34	0.00338	0.00707	PASS
Extreme (80°C)		1.61	6.21	0.00092	0.00356	PASS
Extreme (70°C)		17.52	13.25	0.01004	0.00759	PASS
Extreme (60°C)		7.90	17.71	0.00453	0.01015	PASS
Extreme (50°C)		1.05	16.57	0.00060	0.00950	PASS
Extreme (40°C)		10.27	14.70	0.00589	0.00842	PASS
Extreme (30°C)		4.23	3.76	0.00242	0.00215	PASS
Extreme (20°C)		4.30	5.75	0.00246	0.00330	PASS
Extreme (10°C)		10.55	2.15	0.00605	0.00123	PASS



Condition		Freq.Error (Hz)	Freq.Error (Hz)	Frequency Stability (ppm)	Frequency Stability (ppm)	Verdict
BANDWIDTH	5MHz					
Temperature	Voltage	16QAM	QPSK	16QAM	QPSK	
Extreme (0°C)		9.12	10.59	0.00523	0.00607	PASS
Extreme (-10°C)		10.37	14.68	0.00594	0.00841	PASS
Extreme (-20°C)		7.45	1.37	0.00427	0.00079	PASS
Extreme (-30°C)		2.34	2.19	0.00134	0.00125	PASS
Extreme (-40°C)		13.18	5.08	0.00756	0.00291	PASS
25°C	LV	17.40	14.52	0.00997	0.00832	PASS
	HV	5.39	11.81	0.00309	0.00677	PASS
Condition		Freq.Error (Hz)	Freq.Error (Hz)	Frequency Stability (ppm)	Frequency Stability (ppm)	Verdict
BANDWIDTH	10MHz					
Temperature	Voltage	16QAM	QPSK	16QAM	QPSK	
Normal (25°C)	Normal	15.22	13.34	0.00872	0.00764	PASS
Extreme (90°C)		1.03	12.82	0.00059	0.00734	PASS
Extreme (80°C)		4.61	8.87	0.00264	0.00509	PASS
Extreme (70°C)		10.10	16.50	0.00579	0.00946	PASS
Extreme (60°C)		13.95	13.19	0.00799	0.00756	PASS
Extreme (50°C)		15.59	17.15	0.00894	0.00983	PASS
Extreme (40°C)		2.11	17.05	0.00121	0.00977	PASS
Extreme (30°C)		1.60	9.27	0.00092	0.00531	PASS
Extreme (20°C)		15.90	9.04	0.00911	0.00518	PASS
Extreme (10°C)		17.57	4.51	0.01007	0.00258	PASS
Extreme (0°C)		2.59	11.73	0.00149	0.00672	PASS
Extreme (-10°C)		16.40	17.23	0.00940	0.00988	PASS
Extreme (-20°C)		11.52	11.08	0.00660	0.00635	PASS
Extreme (-30°C)		8.33	17.12	0.00477	0.00981	PASS
Extreme (-40°C)		4.54	15.87	0.00260	0.00910	PASS
25°C	LV	1.42	1.63	0.00081	0.00093	PASS
	HV	11.15	8.22	0.00639	0.00471	PASS
Condition		Freq.Error (Hz)	Freq.Error (Hz)	Frequency Stability (ppm)	Frequency Stability (ppm)	Verdict
BANDWIDTH	10MHz					
Temperature	Voltage	16QAM	QPSK	16QAM	QPSK	
Normal (25°C)	Normal	8.78	17.31	0.00503	0.00992	PASS
Extreme (90°C)		3.88	1.46	0.00222	0.00084	PASS
Extreme (80°C)		6.79	13.04	0.00389	0.00747	PASS
Extreme (70°C)		11.49	17.69	0.00658	0.01014	PASS
Extreme (60°C)		12.67	8.48	0.00726	0.00486	PASS
Extreme (50°C)		10.90	9.36	0.00625	0.00536	PASS
Extreme (40°C)		14.00	17.27	0.00802	0.00990	PASS
Extreme (30°C)		6.48	16.52	0.00372	0.00947	PASS
Extreme (20°C)		7.45	10.11	0.00427	0.00579	PASS



Extreme (10°C)		15.60	13.48	0.00894	0.00772	PASS
Extreme (0°C)		16.10	12.61	0.00923	0.00723	PASS
Extreme (-10°C)		5.13	9.99	0.00294	0.00572	PASS
Extreme (-20°C)		9.28	4.75	0.00532	0.00272	PASS
Extreme (-30°C)		16.15	9.84	0.00926	0.00564	PASS
Extreme (-40°C)		14.66	4.05	0.00840	0.00232	PASS
25°C	LV	16.50	10.71	0.00946	0.00614	PASS
	HV	4.95	10.06	0.00284	0.00576	PASS
Condition		Freq.Error (Hz)	Freq.Error (Hz)	Frequency Stability (ppm)	Frequency Stability (ppm)	Verdict
BANDWIDTH	15MHz					
Temperature	Voltage	16QAM	QPSK	16QAM	QPSK	
Normal (25°C)	Normal	12.78	10.13	0.00732	0.00580	PASS
Extreme (90°C)		8.37	1.90	0.00480	0.00109	PASS
Extreme (80°C)		15.04	12.62	0.00862	0.00723	PASS
Extreme (70°C)		10.40	8.54	0.00596	0.00489	PASS
Extreme (60°C)		17.82	10.25	0.01021	0.00588	PASS
Extreme (50°C)		6.76	15.31	0.00388	0.00878	PASS
Extreme (40°C)		14.85	15.89	0.00851	0.00911	PASS
Extreme (30°C)		3.19	10.75	0.00183	0.00616	PASS
Extreme (20°C)		17.70	1.26	0.01014	0.00072	PASS
Extreme (10°C)		5.97	1.86	0.00342	0.00107	PASS
Extreme (0°C)		10.92	12.20	0.00626	0.00699	PASS
Extreme (-10°C)		5.58	6.00	0.00320	0.00344	PASS
Extreme (-20°C)		14.50	7.77	0.00831	0.00445	PASS
Extreme (-30°C)		1.55	7.95	0.00089	0.00456	PASS
Extreme (-40°C)		10.91	6.32	0.00625	0.00362	PASS
25°C	LV	1.66	4.55	0.00095	0.00261	PASS
	HV	6.26	1.17	0.00359	0.00067	PASS
Condition		Freq.Error (Hz)	Freq.Error (Hz)	Frequency Stability (ppm)	Frequency Stability (ppm)	Verdict
BANDWIDTH	20MHz					
Temperature	Voltage	16QAM	QPSK	16QAM	QPSK	
Normal (25°C)	Normal	7.28	4.13	0.00417	0.00236	PASS
Extreme (90°C)		6.64	8.36	0.00380	0.00479	PASS
Extreme (80°C)		12.09	13.29	0.00693	0.00761	PASS
Extreme (70°C)		7.91	5.61	0.00453	0.00321	PASS
Extreme (60°C)		5.55	12.38	0.00318	0.00709	PASS
Extreme (50°C)		13.40	4.07	0.00768	0.00233	PASS
Extreme (40°C)		2.52	3.36	0.00144	0.00193	PASS
Extreme (30°C)		15.30	5.84	0.00877	0.00335	PASS



Extreme (20°C)		7.38	2.50	0.00423	0.00143	PASS
Extreme (10°C)		11.82	17.85	0.00677	0.01023	PASS
Extreme (0°C)		11.78	8.98	0.00675	0.00515	PASS
Extreme (-10°C)		15.39	13.14	0.00882	0.00753	PASS
Extreme (-20°C)		9.97	16.92	0.00571	0.00970	PASS
Extreme (-30°C)		7.38	8.83	0.00423	0.00506	PASS
Extreme (-40°C)		7.43	15.76	0.00426	0.00903	PASS
25°C	LV	16.00	7.17	0.00917	0.00411	PASS
	HV	17.17	12.25	0.00984	0.00702	PASS

6.6 Spurious Emissions at Antenna Terminals

Sweep the whole frequency band through the range from 9kHz to the 10th harmonic of the carrier, the emissions more than 20 dB below the limit are not reported.

The signal beyond the limit is carrier.

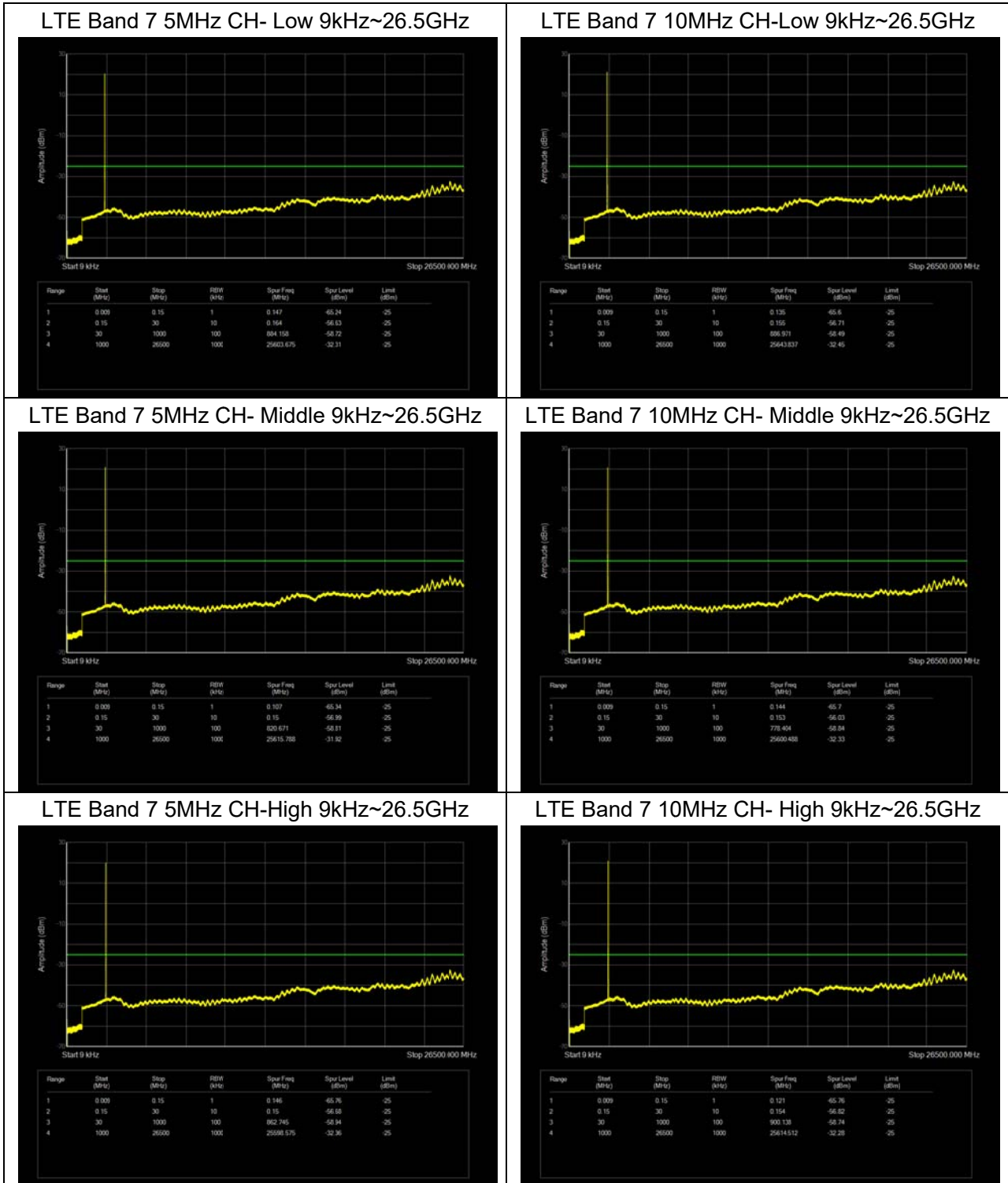



LTE Band 7 15MHz CH- Low 9kHz~26.5GHz

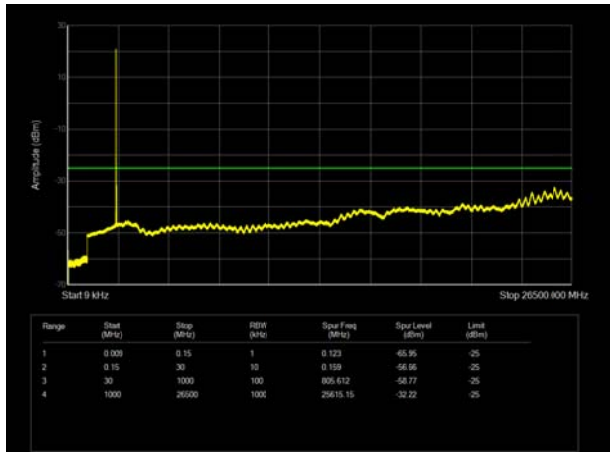

LTE Band 7 20MHz CH-Low 9kHz~26.5GHz

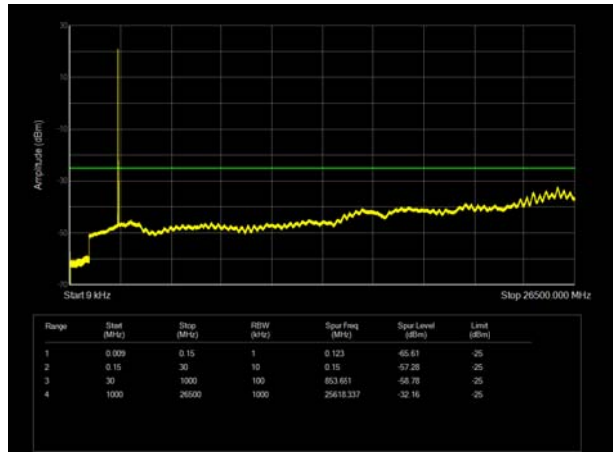

LTE Band 7 15MHz CH- Middle 9kHz~26.5GHz

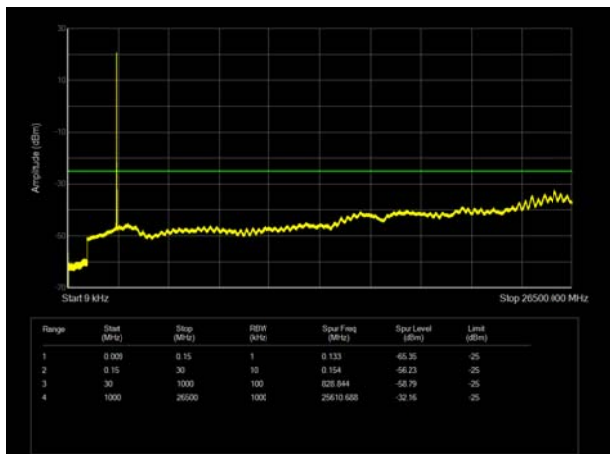

LTE Band 7 20MHz CH- Middle 9kHz~26.5GHz

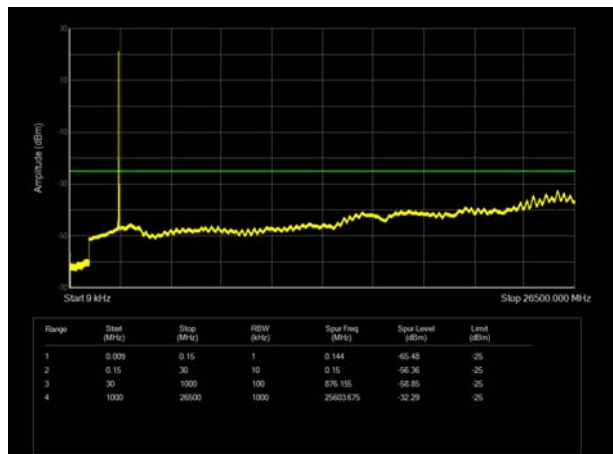

LTE Band 7 15MHz CH-High 9kHz~26.5GHz

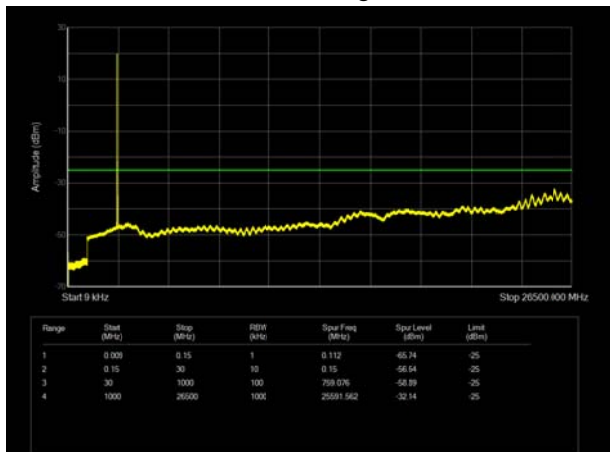

LTE Band 7 20MHz CH- High 9kHz~26.5GHz

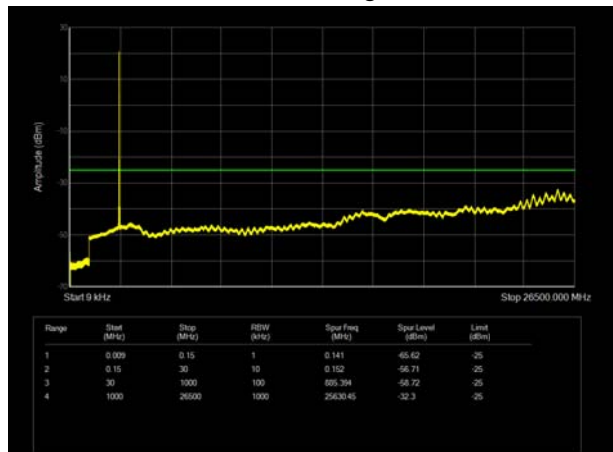



LTE Band 66 1.4MHz CH-Low 9kHz ~20GHz

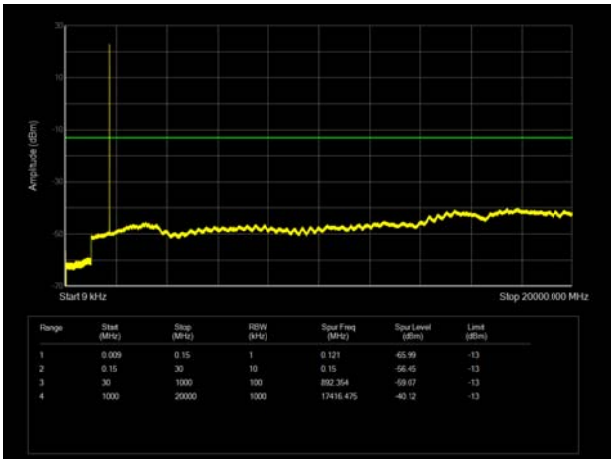

LTE Band 66 3MHz CH-Low 9kHz ~20GHz

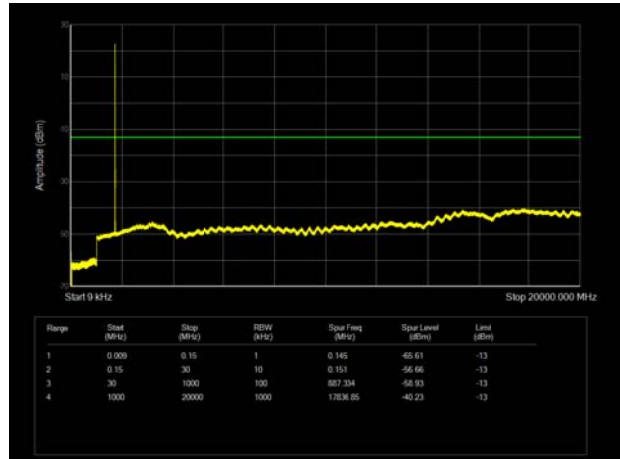

LTE Band 66 1.4MHz CH-Middle 9kHz ~20GHz

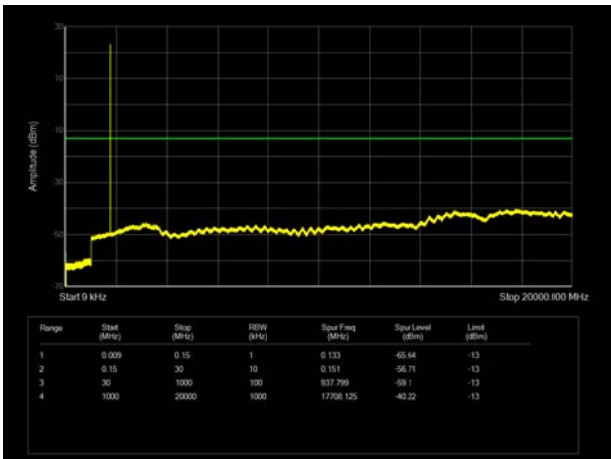

LTE Band 66 3MHz CH-Middle 9kHz ~20GHz

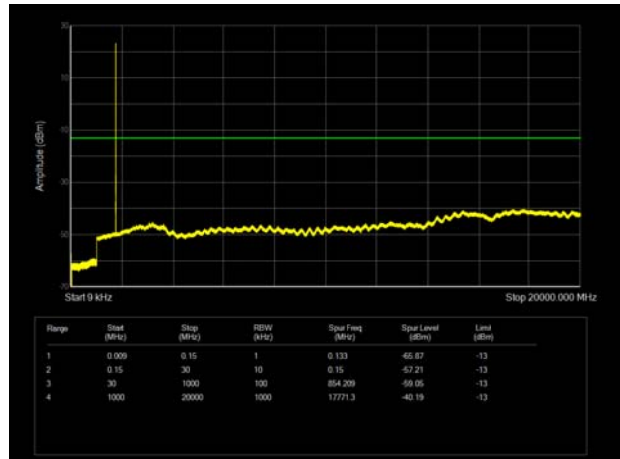

LTE Band 66 1.4MHz CH-High 9kHz ~20GHz

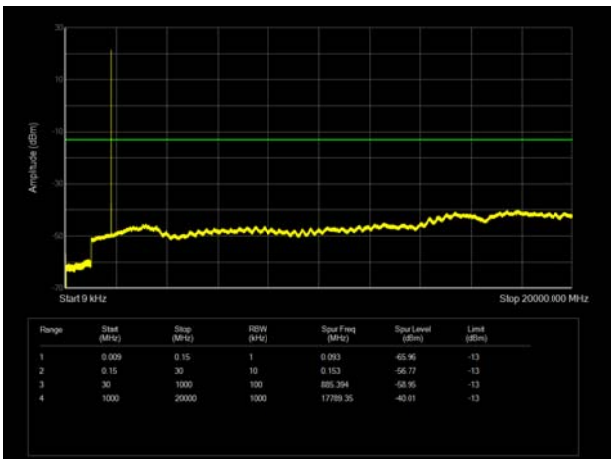

LTE Band 66 3MHz CH-High 9kHz ~20GHz

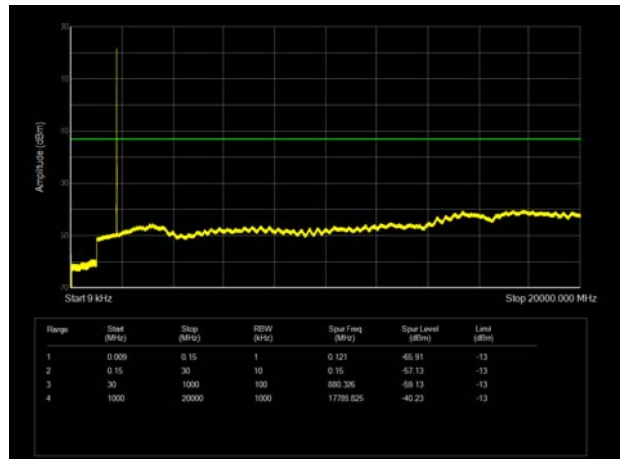



LTE Band 66 5MHz CH-Low 9kHz ~20GHz

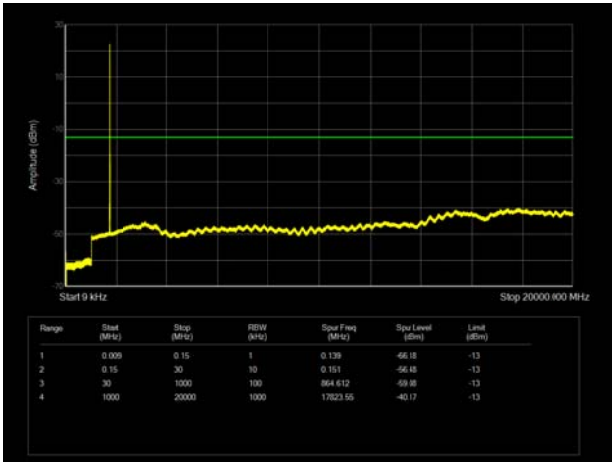

LTE Band 66 10MHz CH-Low 9kHz ~20GHz

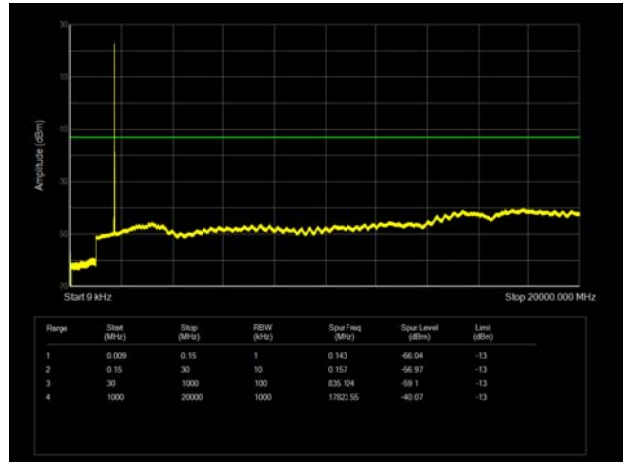

LTE Band 66 5MHz CH-Middle 9kHz ~20GHz

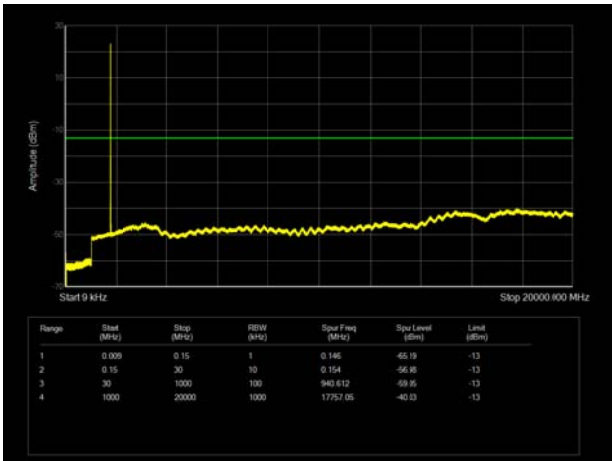

LTE Band 66 10MHz CH-Middle 9kHz ~20GHz

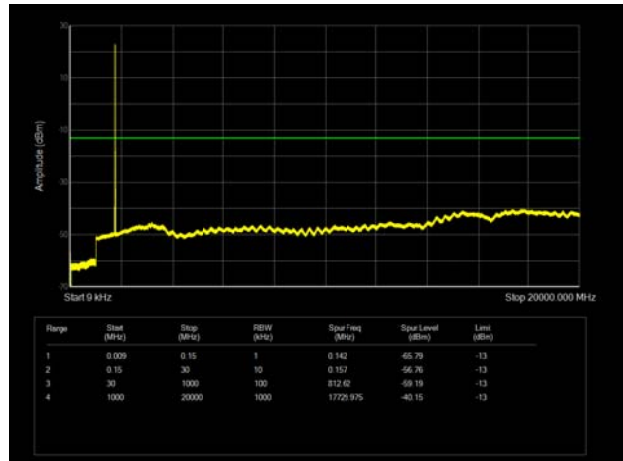

LTE Band 66 5MHz CH-High 9kHz ~20GHz

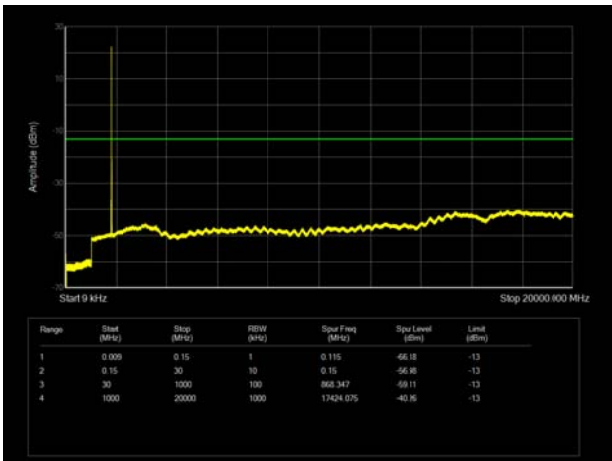

LTE Band 66 10MHz CH-High 9kHz ~20GHz

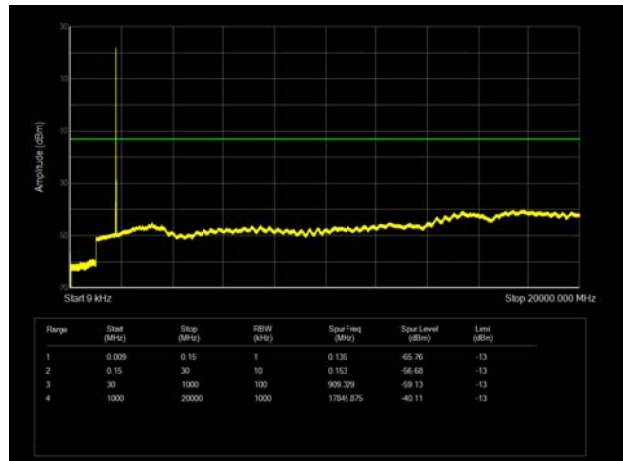



LTE Band 66 15MHz CH-Low 9kHz ~20GHz

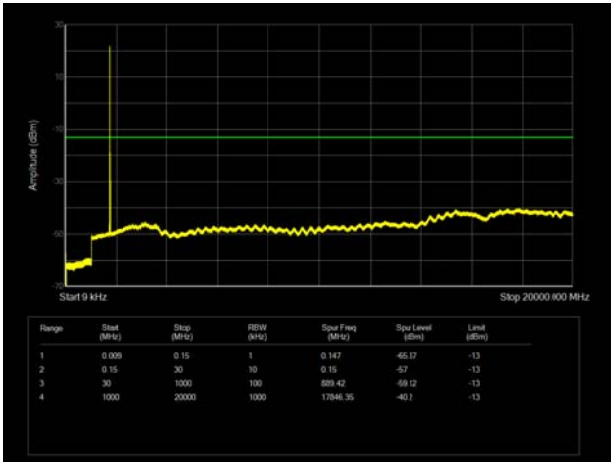

LTE Band 66 20MHz CH-Low 9kHz ~20GHz

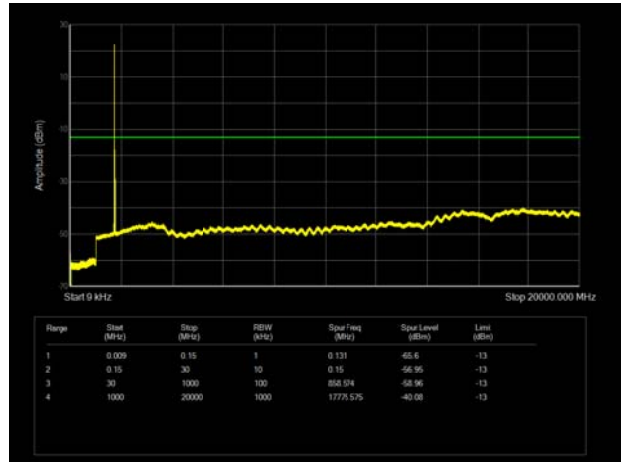

LTE Band 66 15MHz CH-Middle 9kHz ~20GHz

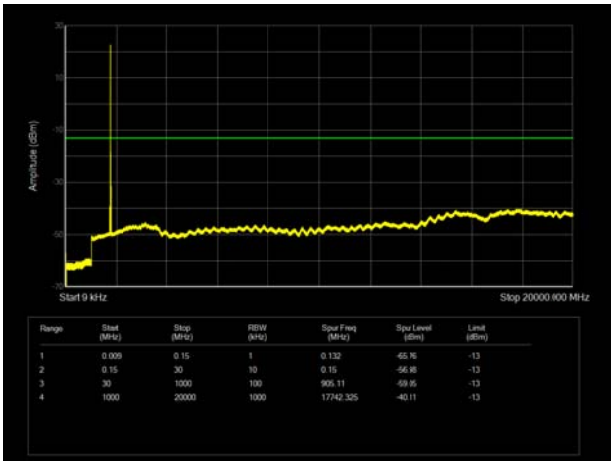

LTE Band 66 20MHz CH-Middle 9kHz ~20GHz

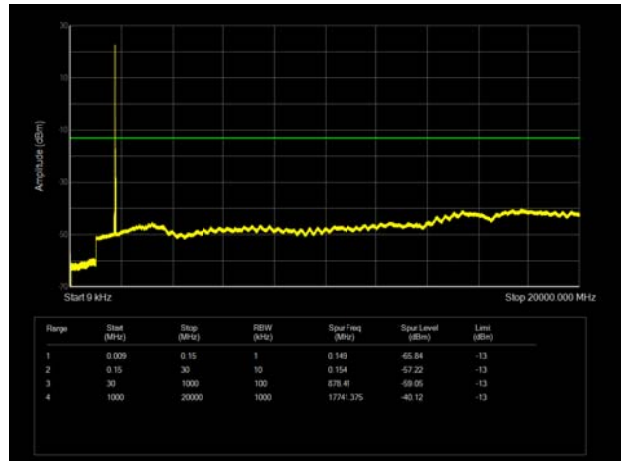

LTE Band 66 15MHz CH-High 9kHz ~20GHz

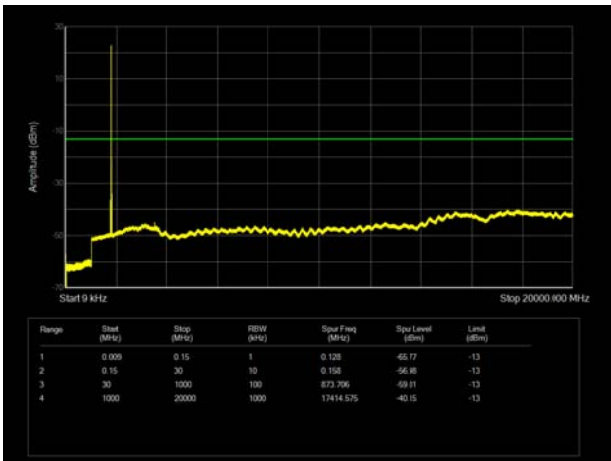

LTE Band 66 20MHz CH-High 9kHz ~20GHz

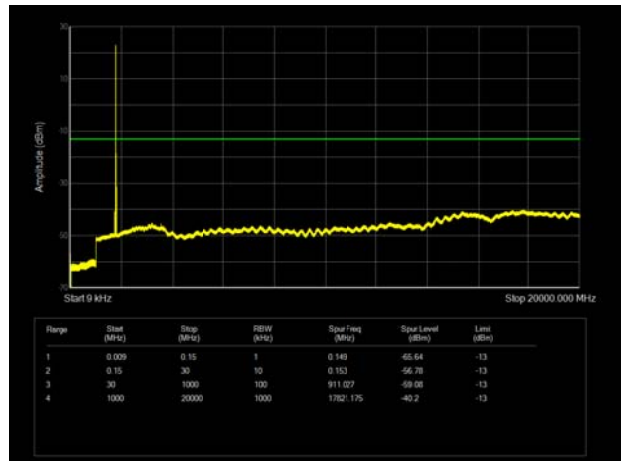



6.7 Radiates Spurious Emission

Sweep the whole frequency band through the range from 9kHz to the 10th harmonic of the carrier, the emissions below the noise floor will not be recorded in the report.

LTE Band 7 QPSK 5MHz CH-Middle, RB 1

Harmonic	Frequency (MHz)	SG (dBm)	Cable Loss (dB)	Gain (dBi)	Antenna Polarization	EIRP Level (dBm)	Limit (dBm)	Margin (dB)	Azimuth (deg)
2	5052.20	-60.92	3.40	12.50	Vertical	-51.82	-25.00	26.82	0
3	7578.30	-58.12	4.40	12.20	Vertical	-50.32	-25.00	25.32	45
4	10104.40	-52.65	4.70	11.30	Vertical	-46.05	-25.00	21.05	90
5	12630.50	-53.84	5.40	13.20	Vertical	-46.04	-25.00	21.04	315
6	15156.60	-52.04	6.10	13.10	Vertical	-45.04	-25.00	20.04	45
7	17745.00	-49.82	6.10	14.20	Vertical	-41.72	-25.00	16.72	0
8	20208.80	--	--	--	--	--	--	--	--
9	22734.90	--	--	--	--	--	--	--	--
10	25261.00	--	--	--	--	--	--	--	--

Note: 1.The other Spurious RF Radiated emissions level is no more than noise floor.

2. The worst emission was found in the antenna is Vertical position.

LTE Band 7 QPSK 20MHz CH-Middle, RB 1

Harmonic	Frequency (MHz)	SG (dBm)	Cable Loss (dB)	Gain (dBi)	Antenna Polarization	EIRP Level (dBm)	Limit (dBm)	Margin (dB)	Azimuth (deg)
2	5065.30	-60.07	3.40	12.50	Vertical	-50.97	-25.00	25.97	45
3	7598.60	-57.94	4.40	12.20	Vertical	-50.14	-25.00	25.14	45
4	10130.63	-55.09	4.70	11.30	Vertical	-48.49	-25.00	23.49	315
5	12675.00	-52.84	5.40	13.20	Vertical	-45.04	-25.00	20.04	90
6	15210.00	-51.99	6.10	13.10	Vertical	-44.99	-25.00	19.99	135
7	17745.00	-49.54	6.10	14.20	Vertical	-41.44	-25.00	16.44	0
8	20280.00	--	--	--	--	--	--	--	--
9	22815.00	--	--	--	--	--	--	--	--
10	25350.00	--	--	--	--	--	--	--	--

Note: 1.The other Spurious RF Radiated emissions level is no more than noise floor.

2. The worst emission was found in the antenna is Vertical position.



LTE Band 66 QPSK 1.4MHz CH-Middle, RB 1

Harmonic	Frequency (MHz)	SG (dBm)	Cable Loss (dB)	Gain (dBi)	Antenna Polarization	EIRP Level (dBm)	Limit (dBm)	Margin (dB)	Azimuth (deg)
2	3509.25	-60.09	2.70	12.70	Vertical	-50.09	-13.00	37.09	135
3	5262.50	-60.75	3.20	12.50	Vertical	-51.45	-13.00	38.45	45
4	7018.00	-57.19	4.20	11.80	Vertical	-49.59	-13.00	36.59	90
5	8772.50	-57.58	4.40	12.50	Vertical	-49.48	-13.00	36.48	270
6	10527.00	-51.40	4.70	11.80	Vertical	-44.30	-13.00	31.30	0
7	12281.50	-55.47	5.20	13.80	Vertical	-46.87	-13.00	33.87	315
8	14036.00	-50.19	5.70	13.20	Vertical	-42.69	-13.00	29.69	90
9	15790.50	-57.05	6.10	16.80	Vertical	-46.35	-13.00	33.35	45
10	17545.00	-50.35	6.10	14.20	Vertical	-42.25	-13.00	29.25	180

Note: 1.The other Spurious RF Radiated emissions level is no more than noise floor.

2. The worst emission was found in the antenna is Vertical position.

LTE Band 66 QPSK 5MHz CH-Middle, RB 1

Harmonic	Frequency (MHz)	SG (dBm)	Cable Loss (dB)	Gain (dBi)	Antenna Polarization	EIRP Level (dBm)	Limit (dBm)	Margin (dB)	Azimuth (deg)
2	3486.00	-61.68	2.70	12.70	Vertical	-51.68	-13.00	38.68	270
3	5229.00	-60.16	3.20	12.50	Vertical	-50.86	-13.00	37.86	180
4	6972.00	-57.46	4.20	11.80	Vertical	-49.86	-13.00	36.86	0
5	8715.00	-56.20	4.40	12.50	Vertical	-48.10	-13.00	35.10	270
6	10458.00	-52.03	4.70	11.80	Vertical	-44.93	-13.00	31.93	90
7	12201.00	-50.86	5.20	13.80	Vertical	-42.26	-13.00	29.26	0
8	13944.00	-50.46	5.70	13.20	Vertical	-42.96	-13.00	29.96	90
9	15687.00	-56.51	6.10	16.80	Vertical	-45.81	-13.00	32.81	315
10	17430.00	-50.65	6.10	14.20	Vertical	-42.55	-13.00	29.55	180

Note: 1.The other Spurious RF Radiated emissions level is no more than noise floor.

2. The worst emission was found in the antenna is Vertical position.



LTE Band 66 QPSK 20MHz CH-Middle, RB 1

Harmonic	Frequency (MHz)	SG (dBm)	Cable Loss (dB)	Gain (dBi)	Antenna Polarization	EIRP Level (dBm)	Limit (dBm)	Margin (dB)	Azimuth (deg)
2	3472.88	-63.51	2.70	12.70	Vertical	-53.51	-13.00	40.51	180
3	5209.00	-63.94	3.20	12.50	Vertical	-54.64	-13.00	41.64	45
4	6945.75	-56.70	4.20	11.80	Vertical	-49.10	-13.00	36.10	45
5	8682.00	-56.75	4.40	12.50	Vertical	-48.65	-13.00	35.65	135
6	10418.63	-52.21	4.70	11.80	Vertical	-45.11	-13.00	32.11	180
7	12455.00	-54.90	5.20	13.80	Vertical	-46.30	-13.00	33.30	90
8	13891.50	-50.48	5.70	13.20	Vertical	-42.98	-13.00	29.98	315
9	15627.00	-55.86	6.10	16.80	Vertical	-45.16	-13.00	32.16	45
10	17364.38	-49.97	6.10	14.20	Vertical	-41.87	-13.00	28.87	0

Note: 1. The other Spurious RF Radiated emissions level is no more than noise floor.

2. The worst emission was found in the antenna is Vertical position.



7 Main Test Instruments

Name	Manufacturer	Type	Serial Number	Calibration Date	Expiration Date
Thermostat	ESPEC	SU-242	93000506	2021-12-12	2022-12-11
Comprehensive tester	R&S	CMW500	150415	2022-05-14	2023-05-13
Spectrum Analyzer	Keysight	N9020A	MY50510203	2021-12-12	2022-12-11
Spectrum Analyzer	R&S	FSV30	100815	2021-12-12	2022-12-11
Horn Antenna	Schwarzbeck	BBHA 9120D	1594	2020-12-17	2023-12-16
Horn Antenna	ETS-Lindgren	3160-09	00102643	2021-10-10	2024-10-09
Testing software	R&S	EMC32	10.35.10		

*****END OF REPORT *****



ANNEX A: The EUT Appearance and Change declaration letter

The EUT Appearance and Change declaration letter are submitted separately.



ANNEX B: Test Setup Photos

The Test Setup Photos are submitted separately.