



RF TEST REPORT

Applicant	Compal Electronics, Inc.
FCC ID	GKREXCN1
Product	4G LCC Module
Brand	COMPAL
Model	EXC-N1
Report No.	R2209A0845-R1V2
Issue Date	October 20, 2022

TA Technology (Shanghai) Co., Ltd. tested the above equipment in accordance with the requirements in **FCC CFR47 Part 2 (2021)/ FCC CFR 47 Part 22H (2021)**. The test results show that the equipment tested is capable of demonstrating compliance with the requirements as documented in this report.

Prepared by: Xu Ying

Approved by: Xu Kai

TA Technology (Shanghai) Co., Ltd.

Building 3, No.145, Jintang Rd, Tangzhen Industry Park, Pudong Shanghai, China

TEL: +86-021-50791141/2/3

FAX: +86-021-50791141/2/3-8000



TABLE OF CONTENT

1. Test Laboratory	5
1.1. Notes of the Test Report	5
1.2. Test facility	5
1.3. Testing Location	5
2. General Description of Equipment under Test.....	6
2.1. Applicant and Manufacturer Information	6
2.2. General Information.....	6
3. Applied Standards.....	7
4. Test Configuration.....	8
5. Test Case.....	10
5.1. RF Power Output and Effective Radiated Power	10
5.2. Occupied Bandwidth	11
5.3. Band Edge.....	12
5.4. Peak-to-Average Power Ratio (PAPR)	13
5.5. Frequency Stability.....	14
5.6. Spurious Emissions at Antenna Terminals	16
5.7. Radiates Spurious Emission	17
6. Test Result	20
6.1. RF Power Output and Effective Radiated Power	20
6.2. Occupied Bandwidth	26
6.3. Band Edge.....	40
6.4. Peak-to-Average Power Ratio (PAPR)	54
6.5. Frequency Stability.....	57
6.6. Spurious Emissions at Antenna Terminals	61
6.7. Radiates Spurious Emission	73
7. Main Test Instruments	78
ANNEX A: The EUT Appearance and Change declaration letter	79
ANNEX B: Test Setup Photos	80



Version	Revision description	Issue Date
Rev.0	Initial issue of report.	September 28, 2022
Rev.1	Update information.	October 19, 2022
Rev.2	Update description.	October 20, 2022

Note: This revised report (Report No. R2209A0845-R1V2) supersedes and replaces the previously issued report (Report No. R2209A0845-R1V1). Please discard or destroy the previously issued report and dispose of it accordingly.



Summary of measurement results

No.	Test Case	Clause in FCC rules	Verdict
1	RF Power Output and Effective Radiated Power	2.1046 22.913(a)(5)	PASS
2	Occupied Bandwidth	2.1049	PASS
3	Band Edge	2.1051 / 22.917(a)	PASS
4	Peak-to-Average Power Ratio	22.913(d)/ KDB 971168 D01(5.7)	PASS
5	Frequency Stability	2.1055 / 22.355	PASS
6	Spurious Emissions at Antenna Terminals	2.1051 / 22.917(a)	PASS
7	Radiates Spurious Emission	2.1053 / 22.917 (a)	PASS

Date of Testing: September 3, 2019 ~ September 24, 2019
Date of Sample Received: (R2208A0783): August 25, 2022

Note: 1. PASS: The EUT complies with the essential requirements in the standard.
FAIL: The EUT does not comply with the essential requirements in the standard.
All indications of Pass/Fail in this report are opinions expressed by TA Technology (Shanghai) Co., Ltd. based on interpretations and/or observations of test results. Measurement Uncertainties were not taken into account and are published for informational purposes only.
2. All test values duplicated from the report (Report No.: R2208A0783-R1).



1. Test Laboratory

1.1. Notes of the Test Report

This report shall not be reproduced in full or partial, without the written approval of **TA technology (shanghai) co., Ltd.** The results documented in this report apply only to the tested sample, under the conditions and modes of operation as described herein. Measurement Uncertainties were not taken into account and are published for informational purposes only. This report is written to support regulatory compliance of the applicable standards stated above.

1.2. Test facility

FCC (Designation number: CN1179, Test Firm Registration Number: 446626)

TA Technology (Shanghai) Co., Ltd. has been listed on the US Federal Communications Commission list of test facilities recognized to perform measurements.

A2LA (Certificate Number: 3857.01)

TA Technology (Shanghai) Co., Ltd. has been listed by American Association for Laboratory Accreditation to perform measurement.

1.3. Testing Location

Company: TA Technology (Shanghai) Co., Ltd.
Address: Building 3, No.145, Jintang Rd, Tangzhen Industry Park, Pudong Shanghai, China
City: Shanghai
Post code: 201201
Country: P. R. China
Contact: Xu Kai
Telephone: +86-021-50791141/2/3
Fax: +86-021-50791141/2/3-8000
Website: <http://www.ta-shanghai.com>
E-mail: xukai@ta-shanghai.com

2. General Description of Equipment under Test

2.1. Applicant and Manufacturer Information

Applicant	Compal Electronics, Inc.
Applicant address	No.581 & 581-1, Ruiguang Rd., Neihu District, Taipei, (114) Taiwan
Manufacturer	Compal Electronics, Inc.
Manufacturer address	No.581 & 581-1, Ruiguang Rd., Neihu District, Taipei, (114) Taiwan

2.2. General Information

EUT Description			
Model	EXC-N1		
IMEI	863879041726491		
Hardware Version	EXC-N1_MB_V1.01		
Software Version	EXC-N1_4.71.5_EQ101		
Power Supply	External Power Supply		
Antenna Type	The EUT don't have standard Antenna. The Antenna used for testing in this report is the after-market accessory.		
Antenna Gain	1.8dBi		
Test Mode(s)	GSM 850; WCDMA Band V; LTE Band 5/26;		
Test Modulation	(GSM)GMSK,8PSK; (WCDMA) BPSK, QPSK,16QAM; (LTE)QPSK 16QAM;		
GPRS Multislot Class	12		
EGPRS Multislot Class	8		
HSDPA UE Category	8		
HSUPA UE Category	6		
LTE Category	4		
Maximum E.R.P.	GSM 850:	32.15dBm	
	WCDMA Band V:	23.40dBm	
	LTE Band 5:	23.22dBm	
	LTE Band 26:	22.90dBm	
Rated Power Supply Voltage	3.8V		
Operating Voltage	Minimum: 3.3V Maximum: 4.2V		
Operating Temperature	Lowest: -40°C Highest: +85°C		
Testing Temperature	Lowest: -40°C Highest: +90°C		
Operating Frequency Range(s)	Band	Tx (MHz)	Rx (MHz)
	GSM850	824 ~ 849	869 ~ 894
	WCDMA Band V	824 ~ 849	869 ~ 894
	LTE Band 5	824 ~ 849	869 ~ 894
	LTE Band 26	824 ~ 849	869 ~ 894
Note: The EUT is sent from the applicant to TA and the information of the EUT is declared by the applicant.			



3. Applied Standards

According to the specifications of the manufacturer, it must comply with the requirements of the following standards:

Test standards:

FCC CFR 47 Part 22H (2021)

FCC CFR47 Part 2 (2021)

Reference standard:

ANSI C63.26-2015

KDB 971168 D01 Power Meas License Digital Systems v03r01

4. Test Configuration

Radiated measurements are performed by rotating the EUT in three different orthogonal test planes. EUT stand-up position (Z axis), lie-down position (X, Y axis). Receiver antenna polarization (horizontal and vertical), the worst emission was found in position (X axis, vertical polarization) and the worst case was recorded.

All mode and data rates and positions were investigated. Subsequently, only the worst case emissions are reported.

The following testing in GSM /WCDMA/LTE is set based on the maximum RF Output Power.

Test modes are chosen to be reported as the worst case configuration below:

Test items	Modes/Modulation	
	GSM 850	WCDMA Band V
RF power output	GSM GPRS EGPRS	RMC HSDPA/HSUPA DC-HSDPA
Effective Radiated Power	GSM GPRS(1Tx slot) EGPRS(1Tx slot)	RMC
Occupied Bandwidth	GSM GPRS(1Tx slot) EGPRS(1Tx slot)	RMC
Band Edge	GSM GPRS(1Tx slot) EGPRS(1Tx slot)	RMC
Peak-to-Average Power Ratio	GSM GPRS(1Tx slot) EGPRS(1Tx slot)	RMC
Frequency Stability	GSM GPRS(1Tx slot) EGPRS(1Tx slot)	RMC
Spurious Emissions at Antenna Terminals	GSM	RMC
Radiates Spurious Emission	GSM	RMC



Test modes are chosen as the worst case configuration below for LTE Band 5/26

Test items	Modes	Bandwidth (MHz)					Modulation		RB			Test Channel		
		1.4	3	5	10	15	QPSK	16QAM	1	50%	100%	L	M	H
RF power output	LTE 5	O	O	O	O	-	O	O	O	O	O	O	O	O
	LTE 26	O	O	O	O	O	O	O	O	O	O	O	O	O
Effective Isotropic Radiated power	LTE 5	O	O	O	O	-	O	O	O	O	O	O	O	O
	LTE 26	O	O	O	O	O	O	O	O	O	O	O	O	O
Occupied Bandwidth	LTE 5	O	O	O	O	-	O	O	-	-	O	O	O	O
	LTE 26	O	O	O	O	O	O	O	-	-	O	O	O	O
Band Edge	LTE 5	O	O	O	O	-	O	O	O	-	O	O	-	O
	LTE 26	O	O	O	O	O	O	O	O	-	O	O	-	O
Peak-to-Average Power Ratio	LTE 5	O	O	O	O	-	O	O	-	-	O	O	O	O
	LTE 26	O	O	O	O	O	O	O	-	-	O	O	O	O
Frequency Stability	LTE 5	O	O	O	O	-	O	O	O	O	O	O	O	O
	LTE 26	O	O	O	O	O	O	O	O	O	O	O	O	O
Spurious Emissions at Antenna Terminals	LTE 5	O	O	O	O	-	O	-	O	-	-	O	O	O
	LTE 26	O	O	O	O	O	O	-	O	-	-	O	O	O
Radiates Spurious Emission	LTE 5	O	-	O	O	-	O	-	O	-	-	-	O	-
	LTE 26	O	-	O	-	O	O	-	O	-	-	-	O	-
Note	1. The mark "O" means that this configuration is chosen for testing. 2. The mark "-" means that this configuration is not testing.													

5. Test Case

5.1. RF Power Output and Effective Radiated Power

Ambient condition

Temperature	Relative humidity	Pressure
23°C ~25°C	45%~50%	101.5kPa

Methods of Measurement

During the process of the testing, The EUT was connected to the Base Station Simulator with a known loss. The EUT is controlled by the Base Station Simulator test set to ensure max power transmission with proper modulation.

ERP can then be calculated as follows:

$$\text{EIRP (dBm)} = \text{Output Power (dBm)} - \text{Losses (dB)} + \text{Antenna Gain (dBi)}$$

where:dBd refers to gain relative to an ideal dipole.

$$\text{EIRP (dBm)} = \text{ERP (dBm)} + 2.15 \text{ (dB)}.$$

Test Setup

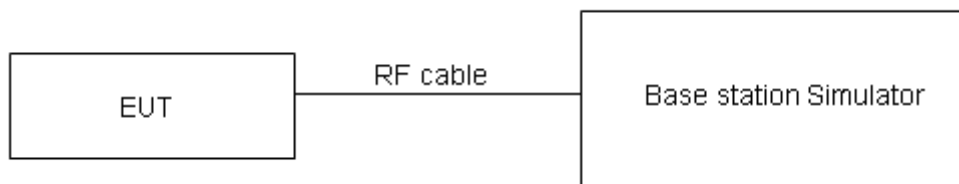

Limits

No specific RF power output requirements in part 2.1046.

Rule Part 22.913(a)(5) specifies that "Mobile/portable stations are limited to 7 watts ERP".

Limit	≤ 7 W (38.45 dBm)
-------	-------------------

Measurement Uncertainty

The assessed measurement uncertainty to ensure 95% confidence level for the normal distribution is with the coverage factor $k = 2$, $U = 0.4 \text{ dB}$ for RF power output, $k = 2$, $U = 1.19 \text{ dB}$ for ERP.

Test Results

Refer to the section 6.1 of this report for test data.

5.2. Occupied Bandwidth

Ambient condition

Temperature	Relative humidity	Pressure
23°C ~25°C	45%~50%	101.5kPa

Method of Measurement

The EUT was connected to Spectrum Analyzer and Base Station Simulator via power Splitter. The occupied bandwidth is measured using spectrum analyzer.

RBW is set to $\geq 1\%EBW$, VBW is set to 3x RBW.

99% power and -26dBc occupied bandwidths are recorded. Spectrum analyzer plots are included on the following pages.

Test Setup

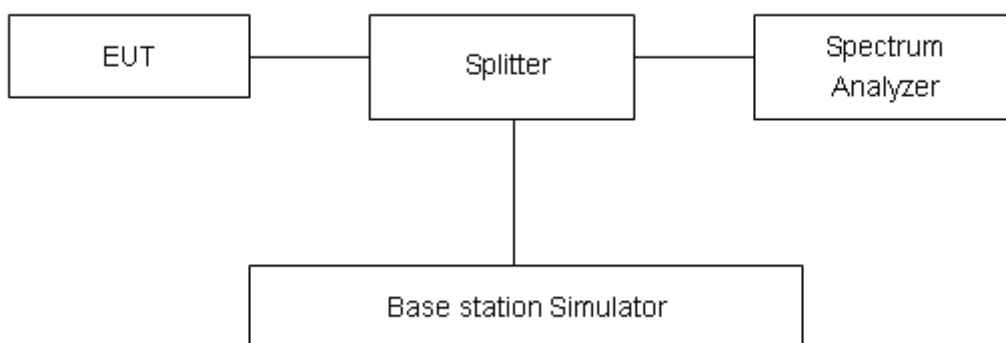

Limits

No specific occupied bandwidth requirements in part 2.1049.

Measurement Uncertainty

The assessed measurement uncertainty to ensure 95% confidence level for the normal distribution is with the coverage factor $k = 2$, $U = 624\text{Hz}$.

Test Results

Refer to the section 6.2 of this report for test data.

5.3. Band Edge

Ambient condition

Temperature	Relative humidity	Pressure
23°C ~25°C	45%~50%	101.5kPa

Method of Measurement

The EUT was connected to Spectrum Analyzer and Base Station Simulator via power Splitter. The band edge of the lowest and highest channels were measured. The average detector is used. RBW is set to $\geq 1\%EBW$, VBW is set to 3x RBW.

Spectrum analyzer plots are included on the following pages.

Test Setup

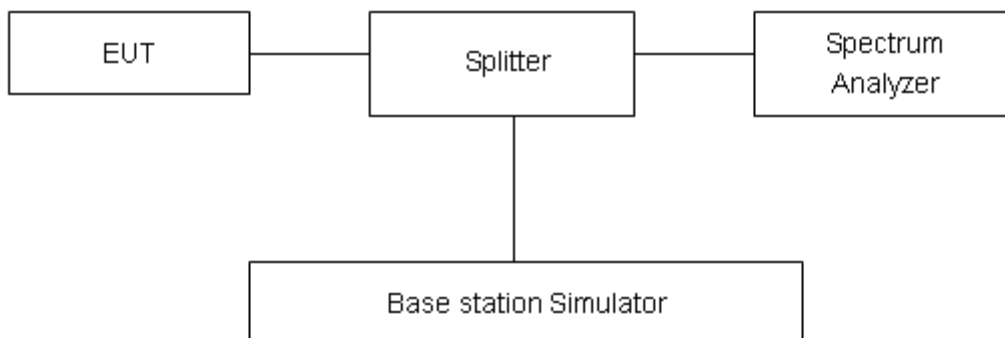

Limits

Rule Part 22.917(a) specifies that “The power of any emission outside of the authorized operating frequency ranges must be attenuated below the transmitting power (P) by a factor of at least 43 + 10 log(P) dB.”

Limit	-13 dBm
-------	---------

Measurement Uncertainty

The assessed measurement uncertainty to ensure 95% confidence level for the normal distribution is with the coverage factor $k = 1.96$, $U=0.684dB$.

Test Results

Refer to the section 6.3 of this report for test data.

5.4. Peak-to-Average Power Ratio (PAPR)

Ambient condition

Temperature	Relative humidity	Pressure
23°C ~25°C	45%~50%	101.5kPa

Methods of Measurement

Measure the total peak power and record as P_{Pk} . And measure the total average power and record as P_{Avg} . Both the peak and average power levels must be expressed in the same logarithmic units (e.g., dBm). Determine the PAPR from:

$$PAPR (dB) = P_{Pk} (dBm) - P_{Avg} (dBm).$$

Test Setup

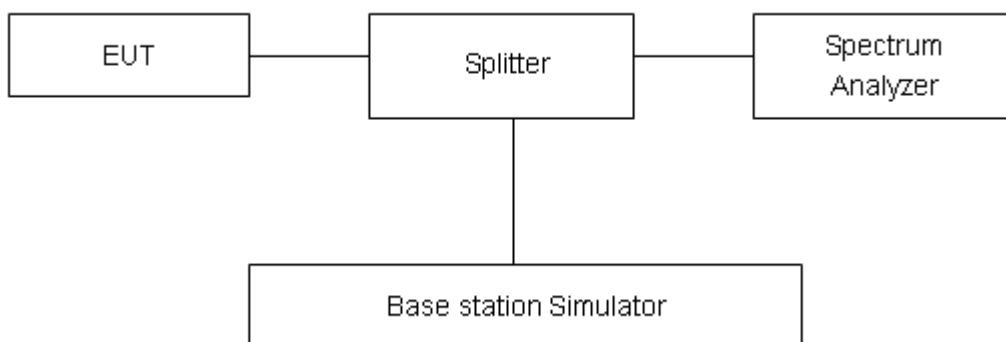

Limits

According to the Sec. 22.913(d), The peak-to-average ratio (PAR) of the transmission must not exceed 13 dB.

Measurement Uncertainty

The assessed measurement uncertainty to ensure 95% confidence level for the normal distribution is with the coverage factor $k = 2$, $U = 0.4$ dB.

Test Results

Refer to the section 6.4 of this report for test data.

5.5. Frequency Stability

Ambient condition

Temperature	Relative humidity	Pressure
23°C ~25°C	45%~50%	101.5kPa

Method of Measurement

Frequency Stability (Temperature Variation)

The temperature inside the climate chamber is varied from -40°C to +85°C in 10°C step size,

(1) With all power removed, the temperature was decreased to 0°C and permitted to stabilize for three hours.

(2) Measure the carrier frequency with the test equipment in a “call mode”. These measurements should be made within 1 minute of powering up the mobile station, to prevent significant self warming.

(3) Repeat the above measurements at 10°C increments from -40°C to +85°C. Allow at least 1.5 hours at each temperature, un-powered, before making measurements. Frequency Stability (Voltage Variation)

The frequency stability shall be measured with variation of primary supply voltage as follows:

Primary Supply Voltage: The primary supply voltage is varied from 85% to 115% of the nominal value for non hand-carried battery and AC powered equipment. For hand-carried, battery-powered equipment, primary supply voltage is reduced to the battery operating end point which shall be specified by the manufacturer.

This transceiver is specified to operate with an input voltage of between 3.3 V and 4.2 V, with a nominal voltage of 3.8V.

Test setup

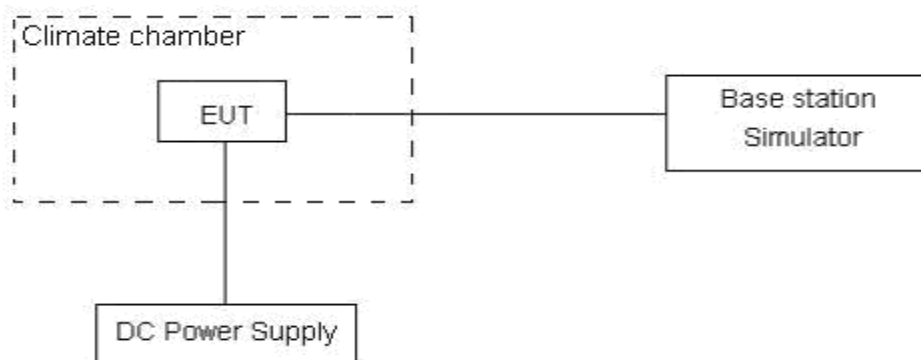

Limits

According to the Sec. 22.355, the frequency stability of the carrier shall be accurate to within 2.5 ppm of the received frequency for mobile stations.

Limits	≤ 2.5 ppm
--------	-----------

Measurement Uncertainty

The assessed measurement uncertainty to ensure 99.75% confidence level for the normal distribution is with the coverage factor $k = 3$, $U = 0.01\text{ppm}$.



Test Results

Refer to the section 6.5 of this report for test data.

5.6. Spurious Emissions at Antenna Terminals

Ambient condition

Temperature	Relative humidity	Pressure
23°C ~25°C	45%~50%	101.5kPa

Method of Measurement

The EUT was connected to Spectrum Analyzer and Base Station Simulator via power Splitter. The measurement is carried out using a spectrum analyzer. The spectrum analyzer scans from 9kHz to the 10th harmonic of the carrier.

The peak detector is used. RBW are set to 100 kHz and VBW are set to 300 kHz for below 1G, RBW are set to 1MHz and VBW are set to 3MHz for above 1G, Sweep is set to ATUO.

The modulation mode and RB allocation refer to section 5.1, using the maximum output power configuration.

Test setup

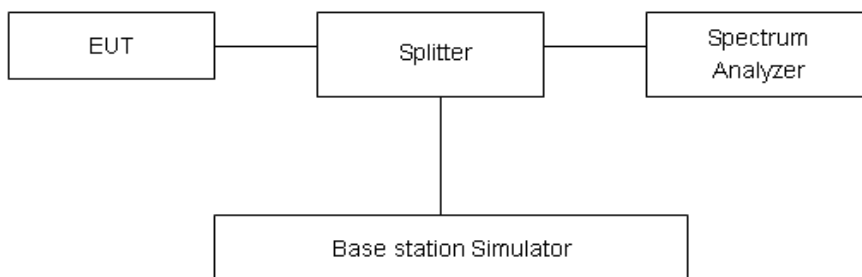

Limits

Rule Part 22.917(a) specifies that “The power of any emission outside of the authorized operating frequency ranges must be attenuated below the transmitting power (P) by a factor of at least 43 + 10 log (P) dB.”

Limit	-13 dBm
-------	---------

Measurement Uncertainty

The assessed measurement uncertainty to ensure 99.75% confidence level for the normal distribution is with the coverage factor $k = 1.96$.

Frequency	Uncertainty
9kHz-1GHz	0.684 dB
1GHz-18GHz	1.407 dB

Test Results

Refer to the section 6.6 of this report for test data.

5.7. Radiates Spurious Emission

Ambient condition

Temperature	Relative humidity	Pressure
23°C ~25°C	45%~50%	101.5kPa

Method of Measurement

1. The testing follows FCC KDB 971168 v03r01 Section 5.8 and ANSI C63.26-2015.
2. Below 1GHz: The EUT is placed on a turntable 0.8 meters above the ground in the chamber, 3 meter away from the antenna. The maximal emission value is acquired by adjusting the antenna height, polarisation and turntable azimuth. Normally, the height range of antenna is 1 m to 4 m, the azimuth range of turntable is 0° to 360°, and the receive antenna has two polarizations Vertical (V) and Horizontal (H). Above 1GHz: (Note: the FCC's permission to use 1.5m as an alternative per TCBC Conf call of Dec. 2, 2014.) The EUT is placed on a turntable 1.5 meters above the ground in the chamber, 3 meter away from the antenna. The maximal emission value is acquired by adjusting the antenna height, polarisation and turntable azimuth. Normally, the height range of antenna is 1 m to 4 m, the azimuth range of turntable is 0° to 360°, and the receive antenna has two polarizations Vertical (V) and Horizontal (H).
3. A loop antenna, A log-periodic antenna or horn antenna shall be substituted in place of the EUT. The log-periodic antenna will be driven by a signal generator and the level will be adjusted till the same power value on the spectrum analyzer or receiver. The level of the spurious emissions can be calculated through the level of the signal generator, cable loss, the gain of the substitution antenna and the reading of the spectrum analyzer or receiver.
4. The EUT is then put into continuously transmitting mode at its maximum power level during the test. Set Test Receiver or Spectrum RBW=100kHz,VBW=300kHz, and the maximum value of the receiver should be recorded as (Pr).
5. The EUT shall be replaced by a substitution antenna. In the chamber, an substitution antenna for the frequency band of interest is placed at the reference point of the chamber. An RF Signal source for the frequency band of interest is connected to the substitution antenna with a cable that has been constructed to not interfere with the radiation pattern of the antenna. A power (PMea) is applied to the input of the substitution antenna, and adjust the level of the signal generator output until the value of the receiver reach the previously recorded (Pr). The power of signal source (PMea) is recorded. The test should be performed by rotating the test item and adjusting the receiving antenna polarization.
6. A amplifier should be connected to the Signal Source output port. And the cable should be connect between the Amplifier and the Substitution Antenna. The cable loss (Pcl), the Substitution Antenna Gain (Ga) and the Amplifier Gain (PAg) should be recorded after test.
7. The measurement results are obtained as described below:
Power(EIRP)=PMea- PAg - Pcl + Ga
The measurement results are amend as described below:
Power(EIRP)=PMea- Pcl + Ga
8. This value is EIRP since the measurement is calibrated using an antenna of known gain (2.15 dB) and known input power. ERP can be calculated from EIRP by subtracting the gain of the dipole, ERP

= EIRP-2.15dB.

The modulation mode and RB allocation refer to section 5.1, using the maximum output power configuration.

Test setup

9KHz~ 30MHz

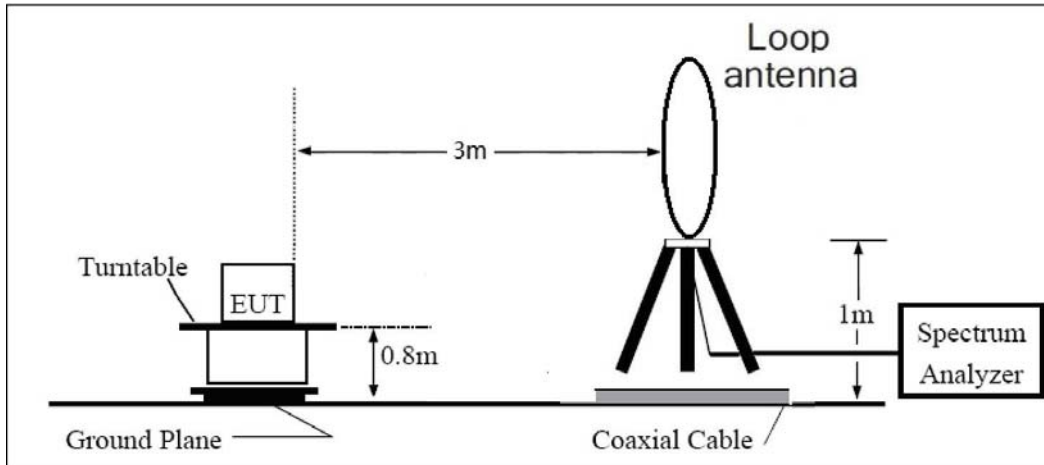

30MHz~ 1GHz

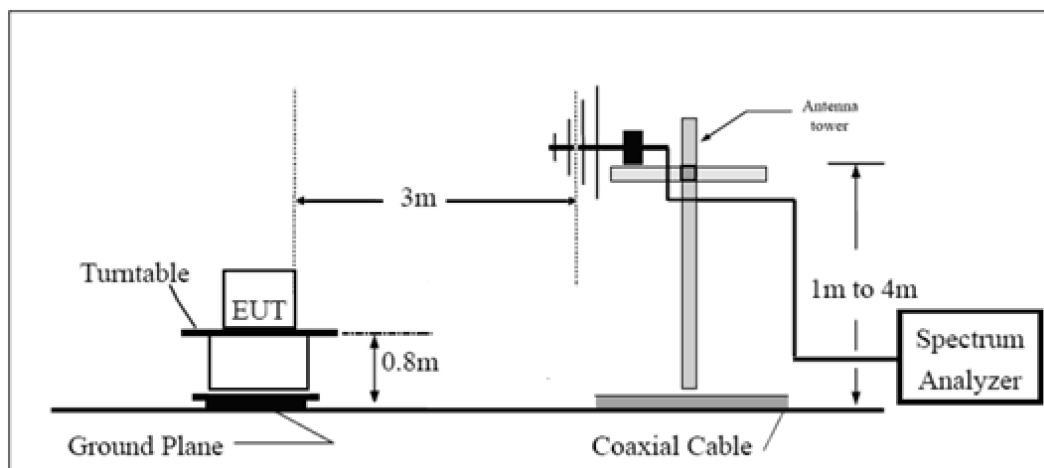

Above 1GHz

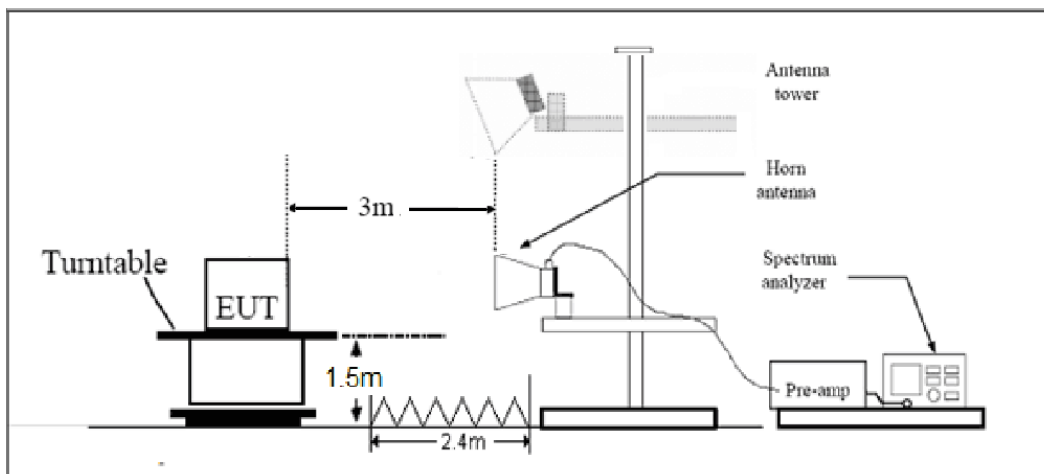

Note: Area side:2.4mX3.6m



Limits

Rule Part 22.917(a) specifies that “The power of any emission outside of the authorized operating frequency ranges must be attenuated below the transmitting power (P) by a factor of at least $43 + 10 \log (P)$ dB.”

Limit	-13 dBm
-------	---------

Measurement Uncertainty

The assessed measurement uncertainty to ensure 95% confidence level for the normal distribution is with the coverage factor $k = 1.96$, $U = 3.55$ dB.

Test Results

Refer to the section 6.7 of this report for test data.

6. Test Result

6.1. RF Power Output and Effective Radiated Power

GSM 850		Maximum Output Power (dBm)			ERP (dBm)		
		Channel 128	Channel 190	Channel 251	Channel 128	Channel 190	Channel 251
		824.2 (MHz)	836.6 (MHz)	848.8 (MHz)	824.2 (MHz)	836.6 (MHz)	848.8 (MHz)
GSM(GMSK)	Results	32.29	32.32	32.34	31.94	31.97	31.99
GPRS (GMSK)	1TXslot	32.50	32.37	32.31	32.15	32.02	31.96
	2TXslots	32.43	32.29	32.28	32.08	31.94	31.93
	3TXslots	32.31	32.22	32.19	31.96	31.87	31.84
	4TXslots	32.20	32.12	32.13	31.85	31.77	31.78
EGPRS	1TXslot	27.03	27.05	26.93	26.68	26.70	26.58
	2TXslots	26.85	26.80	26.87	26.50	26.45	26.52
	3TXslots	26.93	26.78	26.62	26.58	26.43	26.27
	4TXslots	26.67	26.54	26.30	26.32	26.19	25.95

WCDMA Band V		Maximum Output Power (dBm)			ERP (dBm)		
		Channel 4132	Channel 4183	Channel 4233	Channel 4132	Channel 4183	Channel 4233
		826.4 (MHz)	836.6 (MHz)	846.6 (MHz)	826.4 (MHz)	836.6 (MHz)	846.6 (MHz)
RMC		23.61	23.63	23.75	23.26	23.28	23.40
HSDPA	Sub - Test 1	23.07	23.05	23.19	22.72	22.70	22.84
	Sub - Test 2	23.06	23.07	23.16	22.71	22.72	22.81
	Sub - Test 3	22.53	22.57	22.68	22.18	22.22	22.33
	Sub - Test 4	22.54	22.58	22.66	22.19	22.23	22.31
HSUPA	Sub - Test 1	23.03	23.04	23.14	22.68	22.69	22.79
	Sub - Test 2	22.02	22.02	22.13	21.67	21.67	21.78
	Sub - Test 3	22.49	22.50	22.62	22.14	22.15	22.27
	Sub - Test 4	21.95	21.99	22.10	21.60	21.64	21.75
	Sub - Test 5	22.96	22.97	23.08	22.61	22.62	22.73
DC-HSDPA	Sub - Test 1	22.95	22.99	23.09	22.60	22.64	22.74
	Sub - Test 2	22.94	22.98	23.08	22.59	22.63	22.73
	Sub - Test 3	22.52	22.47	22.59	22.17	22.12	22.24
	Sub - Test 4	22.51	22.46	22.58	22.16	22.11	22.23



LTE Band 5				Maximum Output Power(dBm)			ERP (dBm)		
BW	Modulation	RB size	RB offset	Channel/Frequency(MHz)					
				20407 /824.7	20525 /836.5	20643 /848.3	20407 /824.7	20525 /836.5	20643 /848.3
1.4MHz	QPSK	1	0	23.37	23.17	23.05	23.02	22.82	22.70
		1	2	23.19	23.30	23.15	22.84	22.95	22.80
		1	5	23.55	23.23	23.05	23.20	22.88	22.70
		3	0	21.97	22.04	21.91	21.62	21.69	21.56
		3	2	21.93	22.09	21.85	21.58	21.74	21.50
		3	3	22.16	22.23	21.89	21.81	21.88	21.54
	16QAM	6	0	21.91	22.23	22.01	21.56	21.88	21.66
		1	0	22.22	22.35	21.83	21.87	22.00	21.48
		1	2	22.46	23.11	21.72	22.11	22.76	21.37
		1	5	22.16	22.59	21.61	21.81	22.24	21.26
		3	0	21.00	21.06	21.15	20.65	20.71	20.80
		3	2	21.03	21.18	21.09	20.68	20.83	20.74
		3	3	21.02	21.25	20.95	20.67	20.90	20.60
		6	0	20.96	21.22	21.00	20.61	20.87	20.65
BW	Modulation	RB size	RB offset	Channel/Frequency(MHz)					
				20415 /825.5	20525 /836.5	20635 /847.5	20415 /825.5	20525 /836.5	20635 /847.5
3MHz	QPSK	1	0	23.39	23.18	23.08	23.04	22.83	22.73
		1	7	23.22	23.35	23.19	22.87	23.00	22.84
		1	14	23.57	23.27	23.08	23.22	22.92	22.73
		8	0	22.00	22.09	21.95	21.65	21.74	21.60
		8	4	21.96	22.14	21.89	21.61	21.79	21.54
		8	7	22.18	22.27	21.94	21.83	21.92	21.59
	16QAM	15	0	21.99	22.25	22.05	21.64	21.90	21.70
		1	0	22.24	22.38	21.85	21.89	22.03	21.50
		1	7	22.49	23.15	21.75	22.14	22.80	21.40
		1	14	22.19	22.61	21.64	21.84	22.26	21.29
		8	0	21.03	21.11	21.19	20.68	20.76	20.84
		8	4	21.05	21.22	21.12	20.70	20.87	20.77
		8	7	21.05	21.30	20.99	20.70	20.95	20.64
		15	0	20.99	21.27	21.04	20.64	20.92	20.69
BW	Modulation	RB	RB	Channel/Frequency(MHz)					



		size	offset	20425 /826.5	20525 /836.5	20625 /846.5	20425 /826.5	20525 /836.5	20625 /846.5
5MHz	QPSK	1	0	23.38	23.14	23.06	23.03	22.79	22.71
		1	13	23.20	23.34	23.16	22.85	22.99	22.81
		1	24	23.54	23.22	23.04	23.19	22.87	22.69
		12	0	21.98	22.05	21.92	21.63	21.70	21.57
		12	6	21.93	22.09	21.85	21.58	21.74	21.50
		12	13	22.15	22.24	21.90	21.80	21.89	21.55
		25	0	21.97	22.21	22.00	21.62	21.86	21.65
	16QAM	1	0	22.19	22.36	21.83	21.84	22.01	21.48
		1	13	22.47	23.12	21.73	22.12	22.77	21.38
		1	24	22.16	22.57	21.61	21.81	22.22	21.26
		12	0	21.00	21.09	21.16	20.65	20.74	20.81
		12	6	21.02	21.17	21.08	20.67	20.82	20.73
		12	13	21.03	21.26	20.96	20.68	20.91	20.61
		25	0	20.96	21.22	21.00	20.61	20.87	20.65
BW	Modulation	RB size	RB offset	Channel/Frequency(MHz)					
				20450 /829	20525 /836.5	20600 /844	20450 /829	20525 /836.5	20600 /844
10MHz	QPSK	1	0	23.35	23.10	23.03	23.00	22.75	22.68
		1	25	23.19	23.30	23.14	22.84	22.95	22.79
		1	49	23.52	23.21	23.01	23.17	22.86	22.66
		25	0	21.95	22.00	21.88	21.60	21.65	21.53
		25	13	21.91	22.05	21.82	21.56	21.70	21.47
		25	25	22.12	22.19	21.86	21.77	21.84	21.51
		50	0	21.94	22.16	21.96	21.59	21.81	21.61
	16QAM	1	0	22.17	22.32	21.78	21.82	21.97	21.43
		1	25	22.43	23.10	21.69	22.08	22.75	21.34
		1	49	22.14	22.54	21.59	21.79	22.19	21.24
		25	0	20.97	21.05	21.13	20.62	20.70	20.78
		25	13	20.99	21.15	21.05	20.64	20.80	20.7
		25	25	21.00	21.21	20.92	20.65	20.86	20.57
		50	0	20.94	21.18	20.97	20.59	20.83	20.62



LTE Band 26				Maximum Output Power(dBm)			ERP (dBm)		
BW	Modulation	RB size	RB offset	Channel/Frequency(MHz)					
				26797 /824.7	26915 /836.5	27033 /848.3	26797 /824.7	26915 /836.5	27033 /848.3
1.4MHz	QPSK	1	0	23.20	22.95	22.86	22.85	22.60	22.51
		1	2	23.10	22.88	23.12	22.75	22.53	22.77
		1	5	23.01	23.25	22.89	22.66	22.90	22.54
		3	0	21.99	22.18	21.99	21.64	21.83	21.64
		3	2	21.95	22.16	22.04	21.60	21.81	21.69
		3	3	22.10	22.19	22.12	21.75	21.84	21.77
		6	0	22.04	22.11	22.01	21.69	21.76	21.66
	16QAM	1	0	22.40	22.39	21.88	22.05	22.04	21.53
		1	2	22.54	22.33	21.97	22.19	21.98	21.62
		1	5	22.22	22.84	21.41	21.87	22.49	21.06
		3	0	21.10	21.16	20.99	20.75	20.81	20.64
		3	2	21.13	21.21	21.03	20.78	20.86	20.68
		3	3	21.08	21.36	21.08	20.73	21.01	20.73
		6	0	21.15	21.21	21.17	20.80	20.86	20.82
BW	Modulation	RB size	RB offset	Channel/Frequency(MHz)					
				26805 /825.5	26915 /836.5	27025 /847.5	26805 /825.5	26915 /836.5	27025 /847.5
3MHz	QPSK	1	0	23.17	22.93	22.82	22.82	22.58	22.47
		1	7	23.08	22.84	23.09	22.73	22.49	22.74
		1	14	22.98	23.20	22.85	22.63	22.85	22.50
		8	0	21.96	22.13	21.95	21.61	21.78	21.60
		8	4	21.93	22.12	21.99	21.58	21.77	21.64
		8	7	22.08	22.17	22.08	21.73	21.82	21.73
		15	0	22.02	22.10	21.99	21.67	21.75	21.64
	16QAM	1	0	22.37	22.35	21.85	22.02	22.00	21.50
		1	7	22.51	22.31	21.94	22.16	21.96	21.59
		1	14	22.19	22.82	21.37	21.84	22.47	21.02
		8	0	21.08	21.12	20.96	20.73	20.77	20.61
		8	4	21.10	21.16	20.99	20.75	20.81	20.64
		8	7	21.05	21.31	21.04	20.70	20.96	20.69
		15	0	21.13	21.17	21.12	20.78	20.82	20.77
BW	Modulation	RB size	RB offset	Channel/Frequency(MHz)					
				26815	26915	27015	26815	26915	27015



BW	Modulation	RB size	RB offset	Channel/Frequency(MHz)					
				26840 /829	26915 /836.5	26990 /844	26840 /829	26915 /836.5	26990 /844
5MHz	QPSK	1	0	/826.5	/836.5	/846.5	/826.5	/836.5	/846.5
		1	13	23.19	22.94	22.85	22.84	22.59	22.50
		1	24	23.11	22.89	23.13	22.76	22.54	22.78
		12	0	23.00	23.24	22.88	22.65	22.89	22.53
		12	6	21.99	22.18	21.99	21.64	21.83	21.64
		12	13	21.96	22.17	22.03	21.61	21.82	21.68
		12	13	22.10	22.21	22.13	21.75	21.86	21.78
	25	0	22.10	22.12	22.03	21.75	21.77	21.68	
	16QAM	1	0	22.39	22.38	21.87	22.04	22.03	21.52
		1	13	22.54	22.35	21.97	22.19	22.00	21.62
		1	24	22.22	22.84	21.40	21.87	22.49	21.05
		12	0	21.11	21.17	21.00	20.76	20.82	20.65
		12	6	21.12	21.20	21.02	20.77	20.85	20.67
		12	13	21.08	21.36	21.08	20.73	21.01	20.73
25		0	21.16	21.22	21.16	20.81	20.87	20.81	
10MHz	QPSK	1	0	23.18	22.90	22.83	22.83	22.55	22.48
		1	25	23.09	22.88	23.10	22.74	22.53	22.75
		1	49	22.97	23.19	22.84	22.62	22.84	22.49
		25	0	21.97	22.14	21.96	21.62	21.79	21.61
		25	13	21.93	22.12	21.99	21.58	21.77	21.64
		25	25	22.07	22.18	22.09	21.72	21.83	21.74
		50	0	22.08	22.08	21.98	21.73	21.73	21.63
	16QAM	1	0	22.34	22.36	21.85	21.99	22.01	21.50
		1	25	22.52	22.32	21.95	22.17	21.97	21.60
		1	49	22.19	22.80	21.37	21.84	22.45	21.02
		25	0	21.08	21.15	20.97	20.73	20.80	20.62
		25	13	21.09	21.15	20.98	20.74	20.80	20.63
		25	25	21.06	21.32	21.05	20.71	20.97	20.70
		50	0	21.13	21.17	21.12	20.78	20.82	20.77
15MHz	QPSK	1	0	26865 /831.5	26915 /836.5	26965 /841.5	26865 /831.5	26915 /836.5	26965 /841.5
		1	38	23.15	22.86	22.80	22.80	22.51	22.45



		1	74	22.95	23.18	22.81	22.60	22.83	22.46
		36	0	21.94	22.09	21.92	21.59	21.74	21.57
		36	18	21.91	22.08	21.96	21.56	21.73	21.61
		36	39	22.04	22.13	22.05	21.69	21.78	21.70
		75	0	22.05	22.03	21.94	21.70	21.68	21.59
	16QAM	1	0	22.32	22.32	21.80	21.97	21.97	21.45
		1	38	22.48	22.30	21.91	22.13	21.95	21.56
		1	74	22.17	22.77	21.35	21.82	22.42	21.00
		36	0	21.05	21.11	20.94	20.70	20.76	20.59
		36	18	21.06	21.13	20.95	20.71	20.78	20.6
		36	39	21.03	21.27	21.01	20.68	20.92	20.66
		75	0	21.11	21.13	21.09	20.76	20.78	20.74

6.2. Occupied Bandwidth

Mode	Channel	Frequency (MHz)	99% Power Bandwidth (MHz)	-26dBc Bandwidth(MHz)
GSM 850 (GSM)	128	824.2	0.24535	0.3136
	190	836.6	0.24334	0.3105
	251	848.8	0.24713	0.3107
GPRS 850 (GMSK)	128	824.2	0.24320	0.3121
	190	836.6	0.24447	0.3140
	251	848.8	0.24428	0.3121
EGPRS 850 (8-PSK)	128	824.2	0.24732	0.3013
	190	836.6	0.24563	0.2996
	251	848.8	0.24913	0.2955
WCDMA Band V (RMC)	4132	826.4	4.12430	4.6890
	4183	836.6	4.12470	4.7030
	4233	846.6	4.12910	4.6910

LTE Band 5						
RB	Modulation	Bandwidth (MHz)	Channel	Frequency (MHz)	99% Power Bandwidth(MHz)	-26dBc Bandwidth(MHz)
100%	QPSK	1.4	20407	824.7	1.1224	1.321
			20525	836.5	1.1275	1.338
			20643	848.3	1.1184	1.343
		3	20415	825.5	2.7373	3.056
			20525	836.5	2.7229	3.014
			20635	847.5	2.7405	3.047
		5	20425	826.5	4.5201	5.045
			20525	836.5	4.5304	5.002
			20625	846.5	4.4979	4.956
		10	20450	829	9.0470	10.190
			20525	836.5	8.9989	10.050
			20600	844	9.0183	10.030
	16QAM	1.4	20407	824.7	1.1143	1.319
			20525	836.5	1.1139	1.343



		3	20643	848.3	1.1215	1.347		
			20415	825.5	2.7352	3.042		
			20525	836.5	2.7355	3.052		
		5	20635	847.5	2.7311	3.058		
			20425	826.5	4.5026	4.982		
			20525	836.5	4.4950	5.006		
		10	20625	846.5	4.5169	4.989		
			20450	829	9.0479	9.985		
			20525	836.5	8.9960	9.875		
					20600	844	9.0070	9.966

LTE Band 26							
RB	Modulation	Bandwidth (MHz)	Channel	Frequency (MHz)	99% Power Bandwidth(MHz)	-26dBc Bandwidth(MHz)	
100%	QPSK	1.4	26797	824.7	1.1216	1.336	
			26915	836.5	1.1172	1.333	
			27033	848.3	1.1124	1.333	
		3	26805	825.5	2.7412	3.075	
			26915	836.5	2.7499	3.051	
			27025	847.5	2.7402	3.057	
		5	26815	826.5	4.5253	5.036	
			26915	836.5	4.5101	5.003	
			27015	846.5	4.5077	4.948	
		10	26840	829	9.0377	10.120	
			26915	836.5	8.9992	10.030	
			26990	844	9.0168	10.010	
		15	26865	831.5	13.4620	14.730	
			26915	836.5	13.3820	14.520	
			26965	841.5	13.4140	14.600	
		16QAM	1.4	26797	824.7	1.1279	1.341
				26915	836.5	1.1245	1.329
				27033	848.3	1.1155	1.325
	3		26805	825.5	2.7587	3.077	
			26915	836.5	2.7318	3.060	



			27025	847.5	2.7350	3.043
	5		26815	826.5	4.5146	5.014
			26915	836.5	4.5321	5.002
			27015	846.5	4.5239	5.027
	10		26840	829	9.0341	10.010
			26915	836.5	9.0040	9.964
			26990	844	9.0156	9.922
	15		26865	831.5	13.4710	14.680
			26915	836.5	13.4010	14.560
			26965	841.5	13.4210	14.590

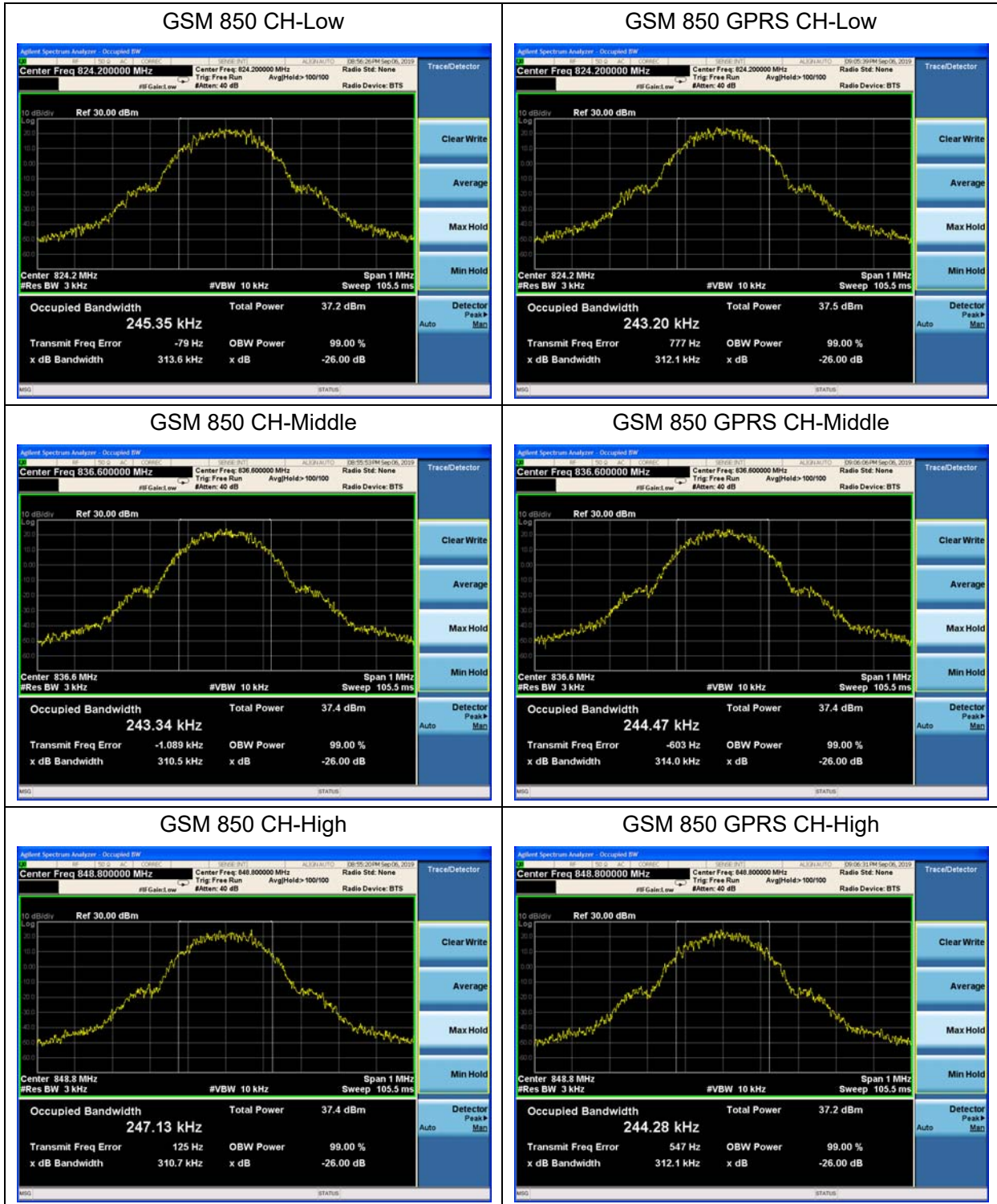

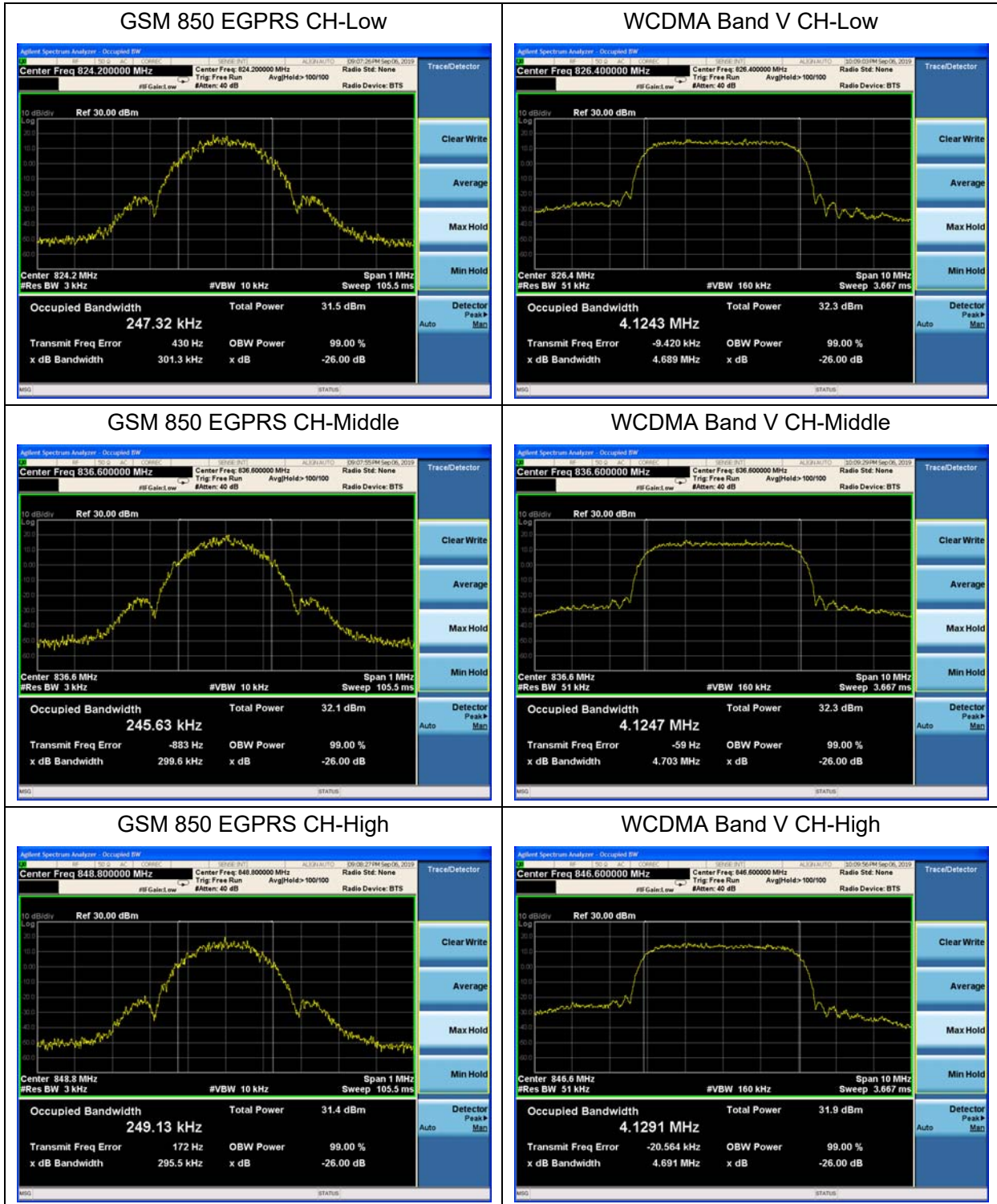

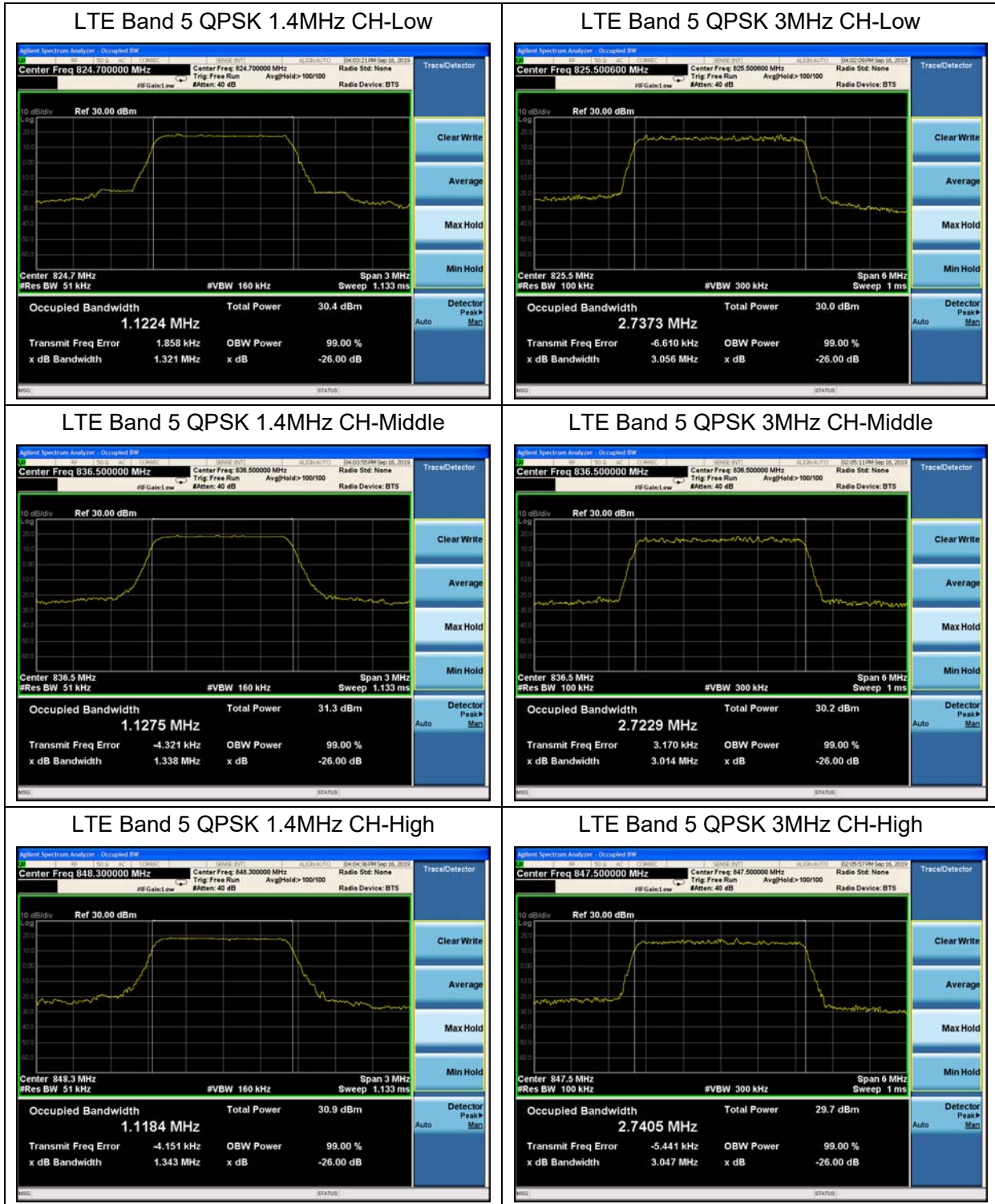

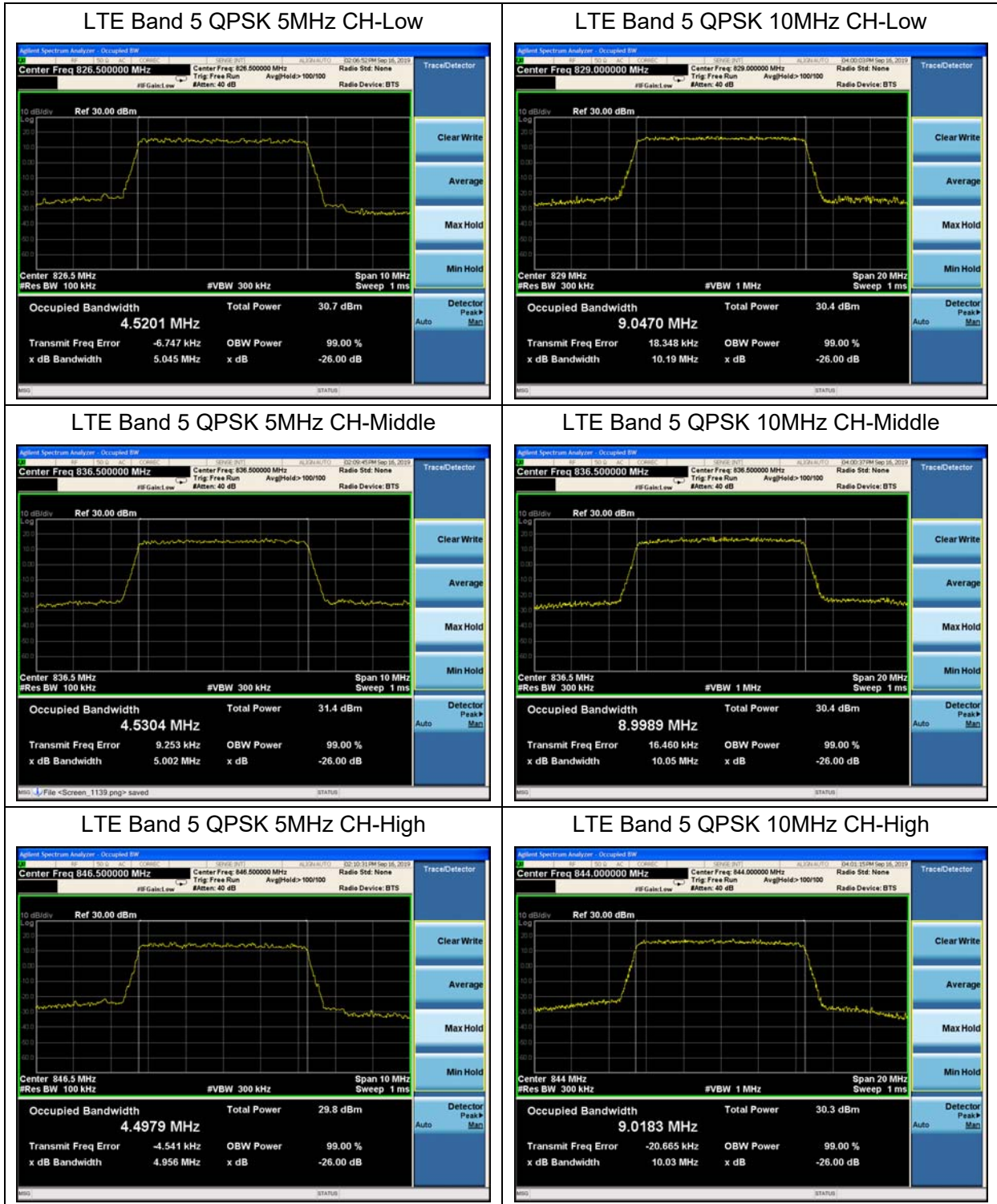



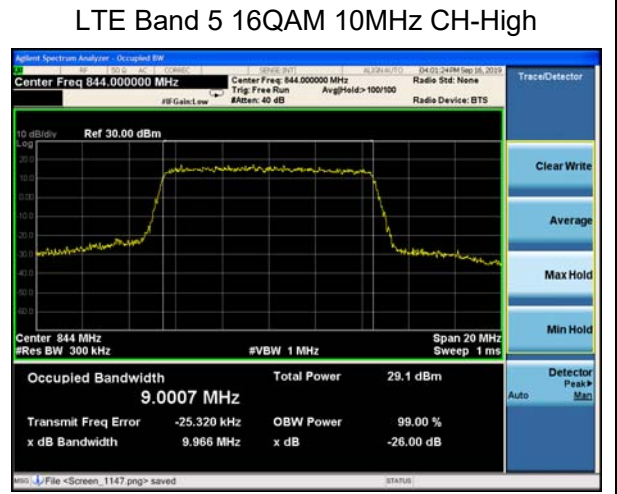
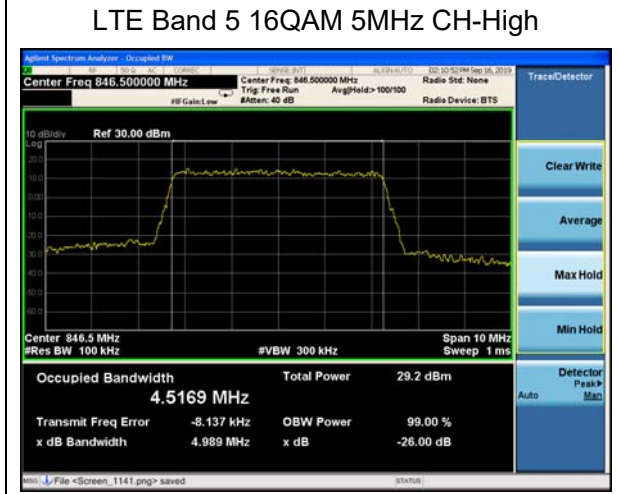
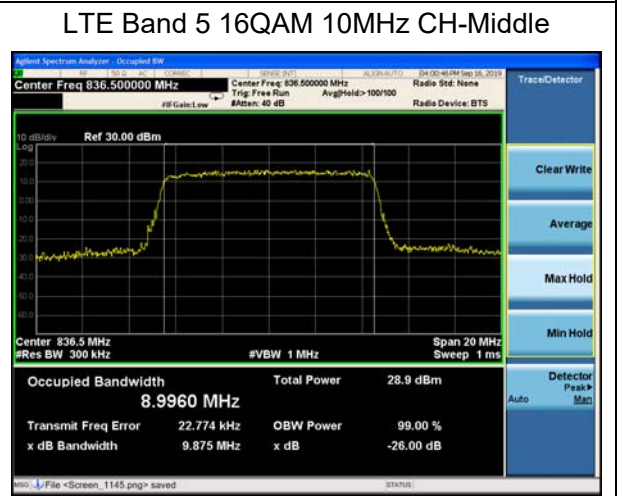
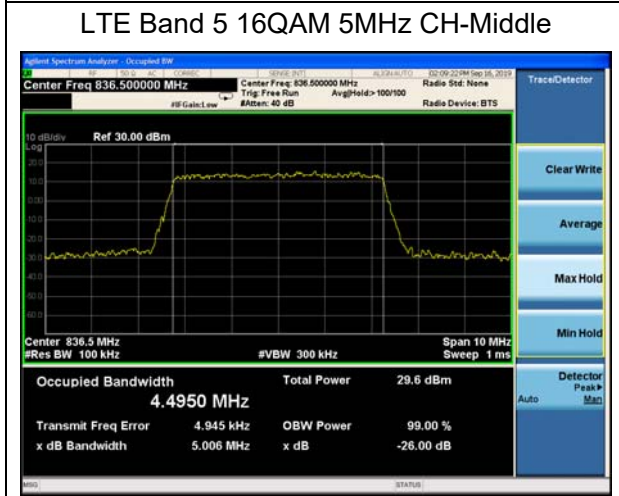
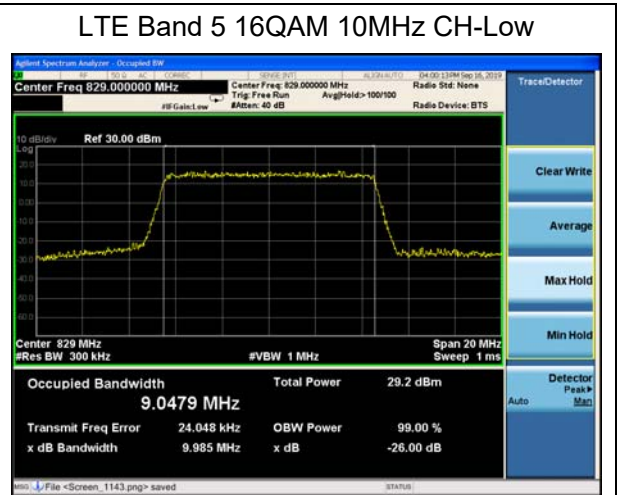
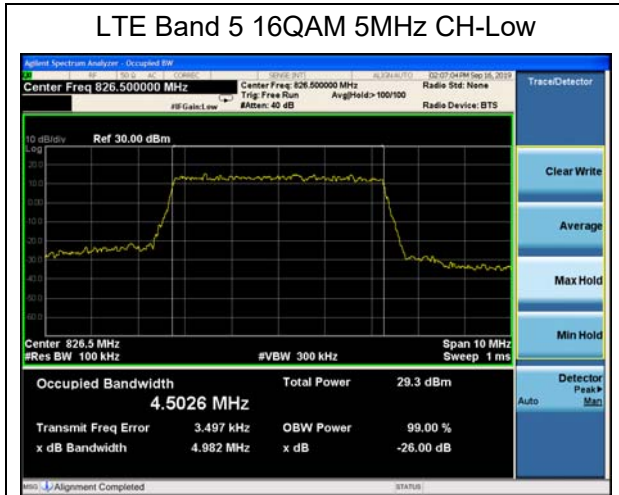

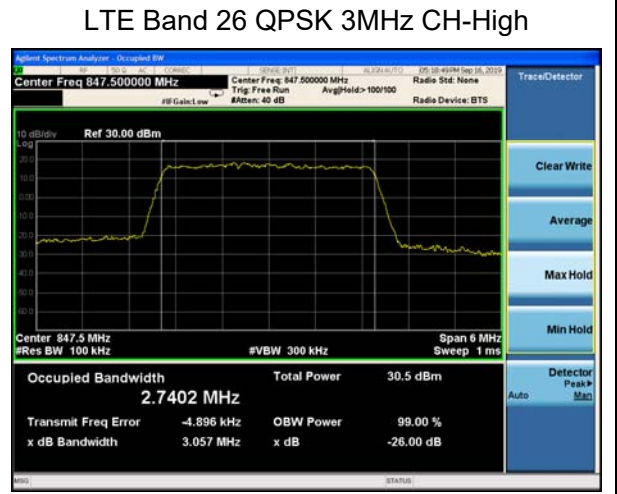
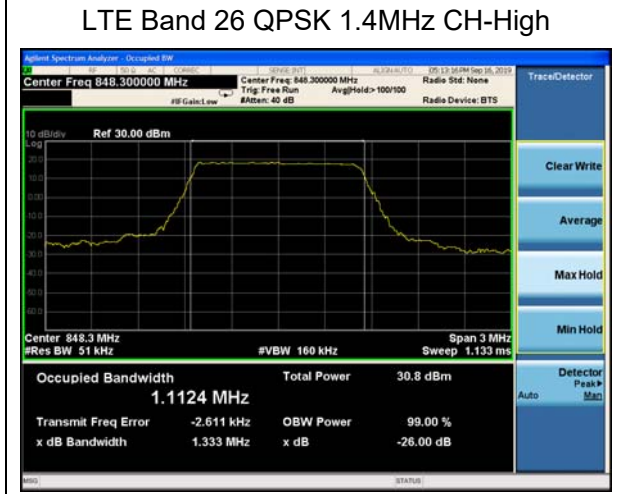
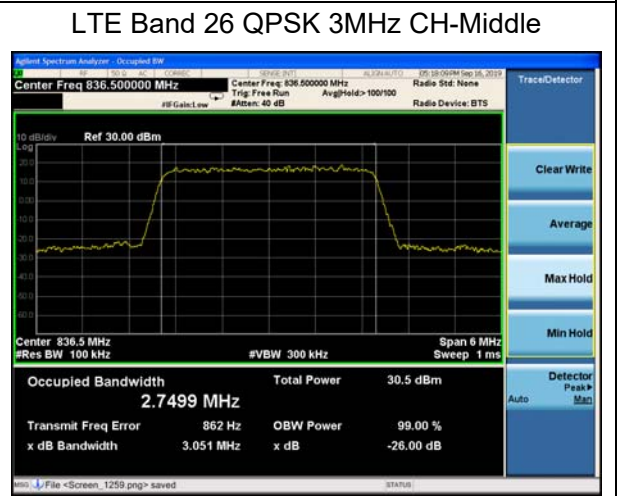
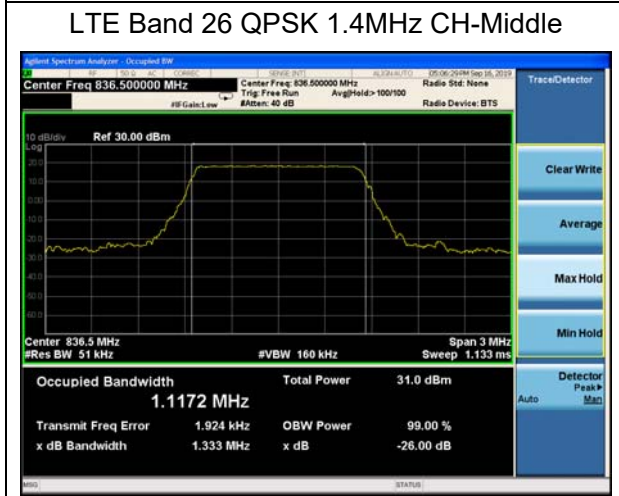
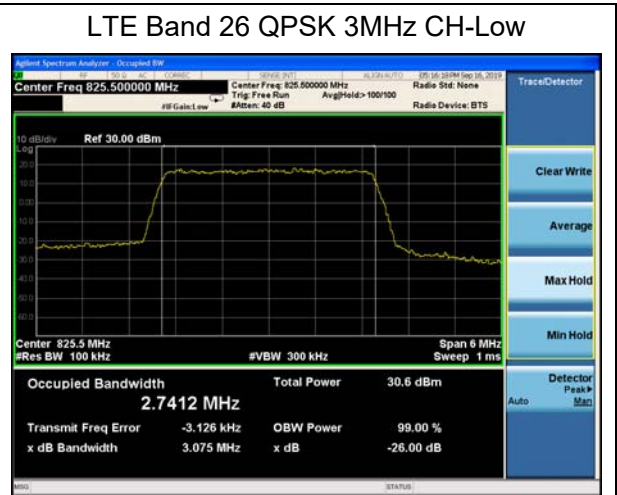
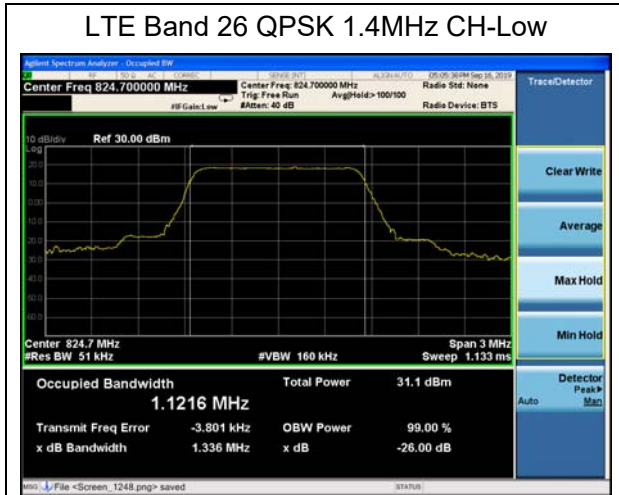

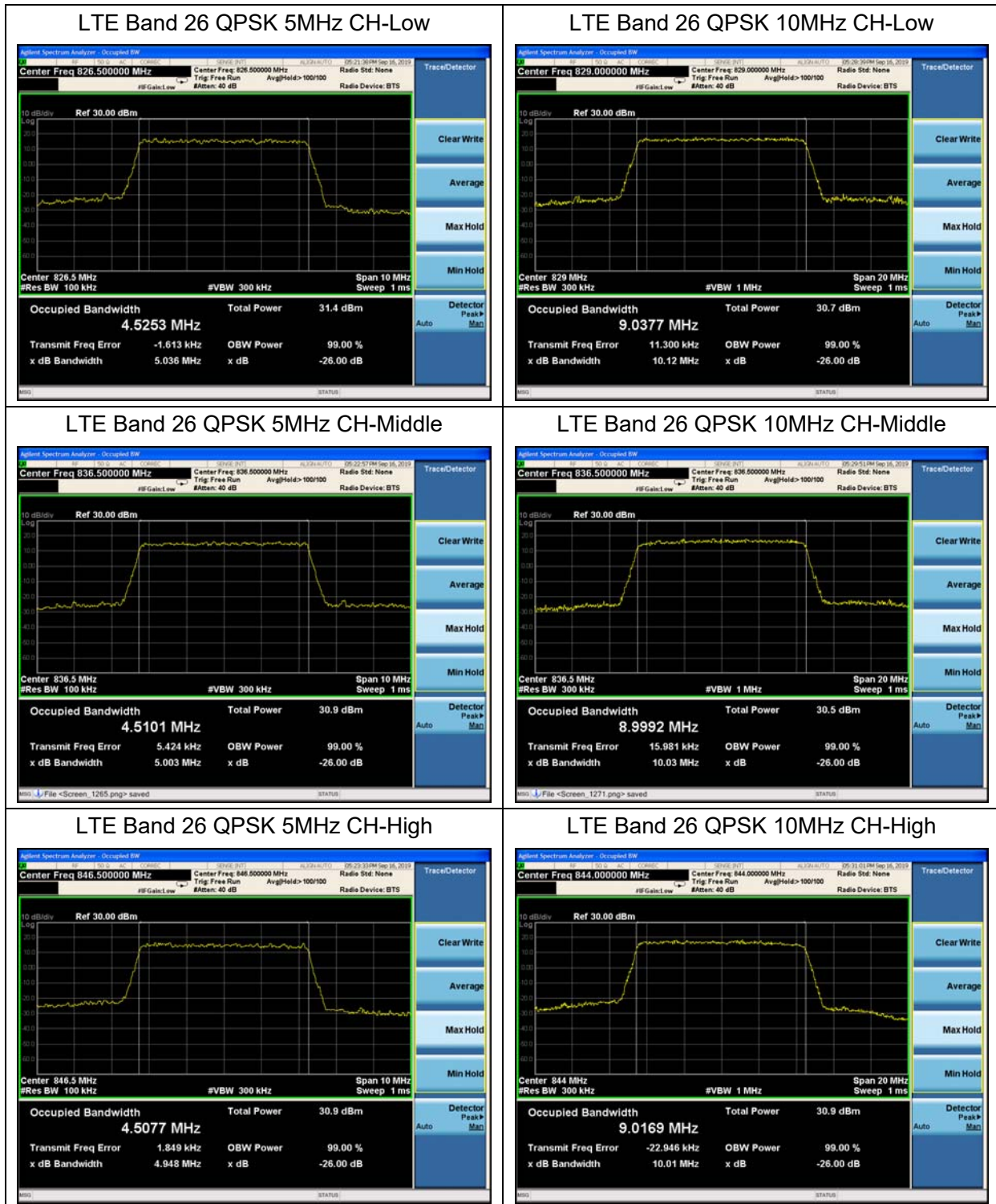

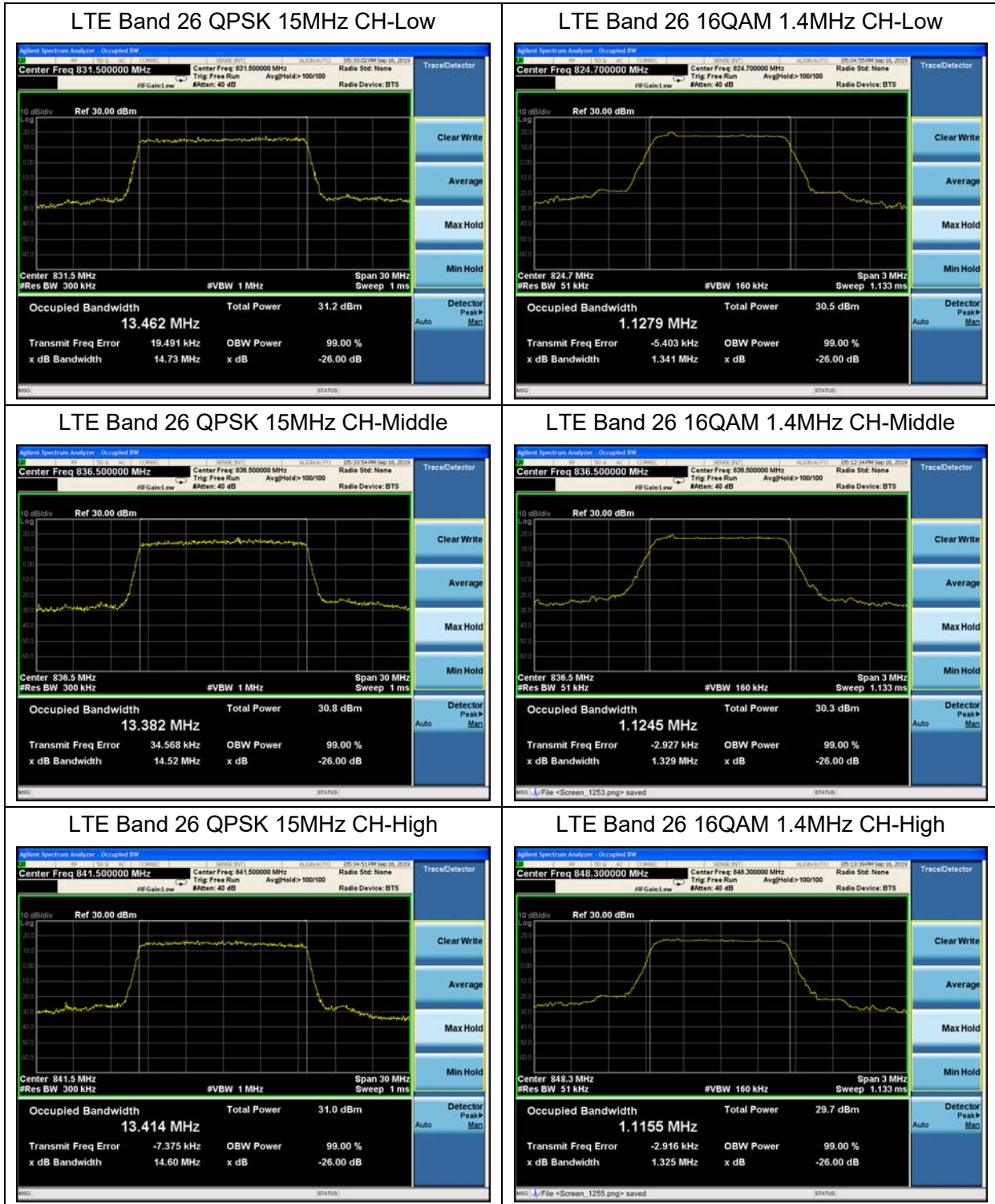

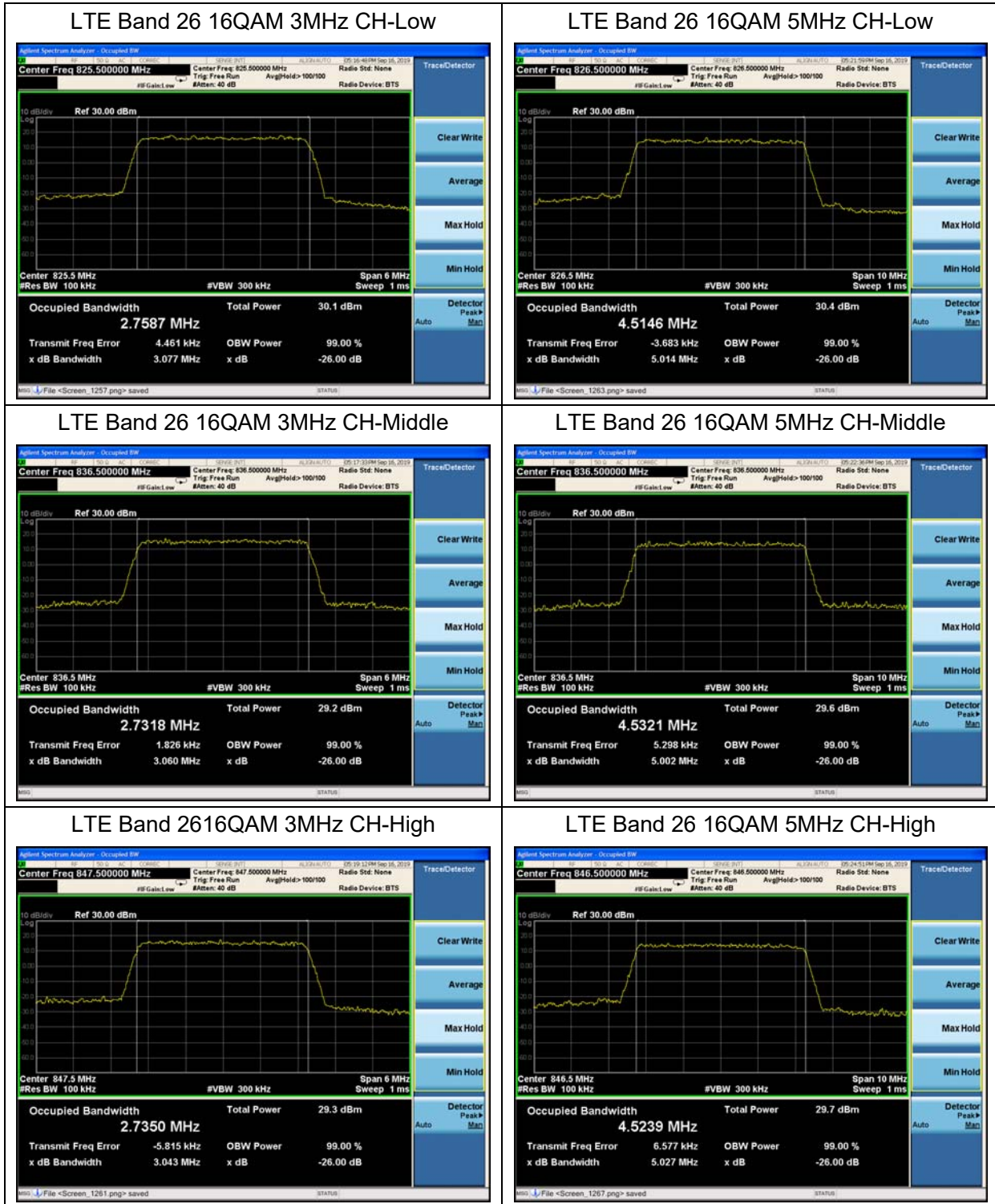

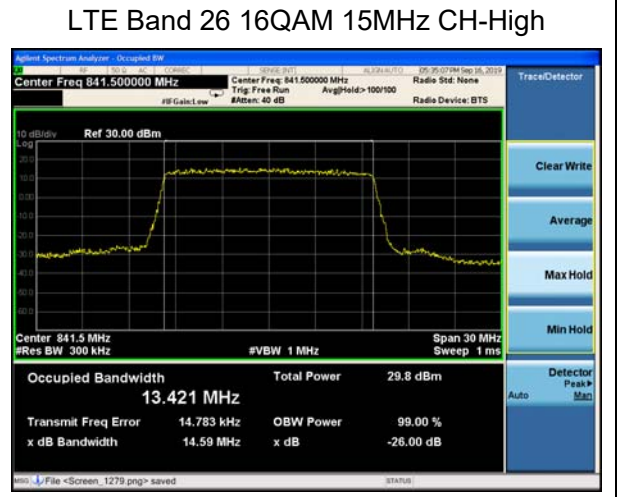
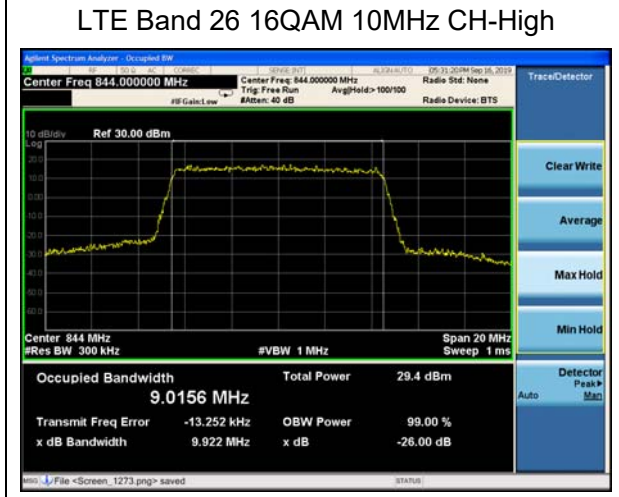
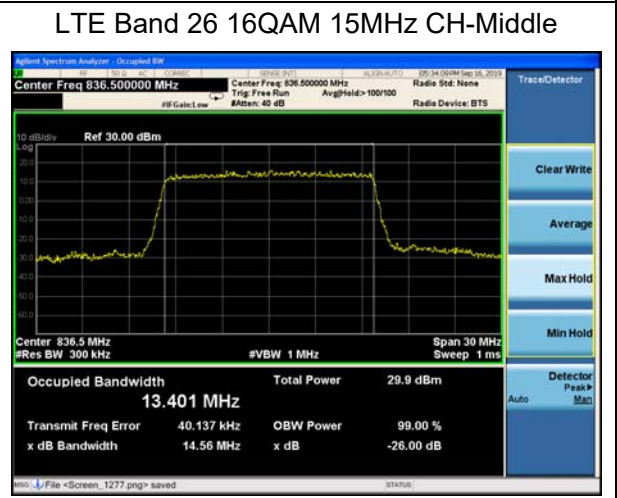
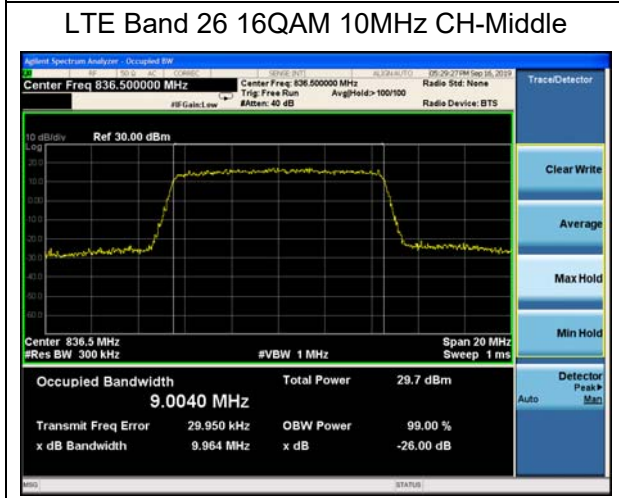
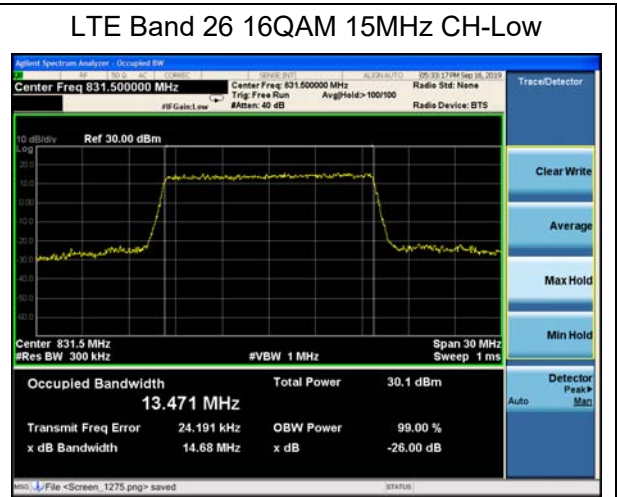
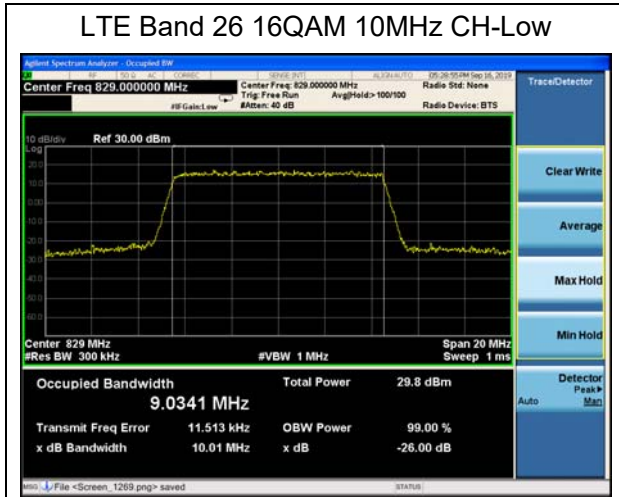

6.3. Band Edge

GSM 850 CH-Low



GSM 850 CH-High

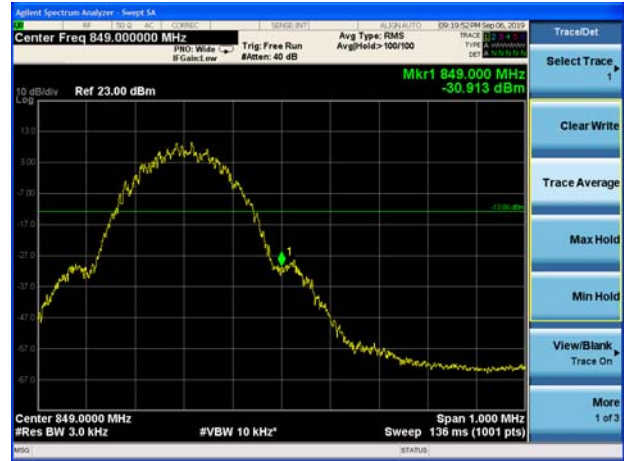

GSM 850 GPRS CH-Low



GSM 850 GPRS CH-High



GSM 850 EGPRS CH-Low

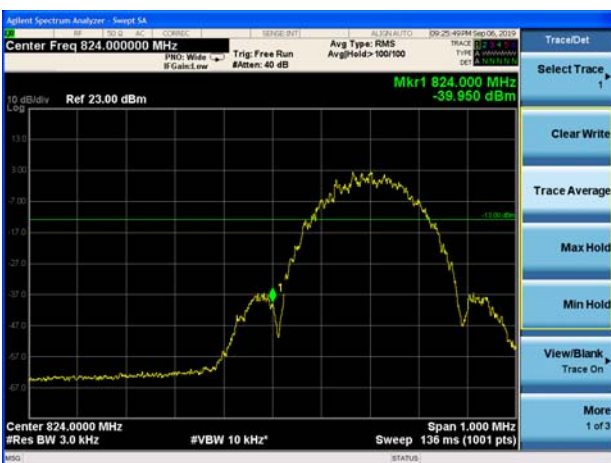

GSM 850 EGPRS CH-High

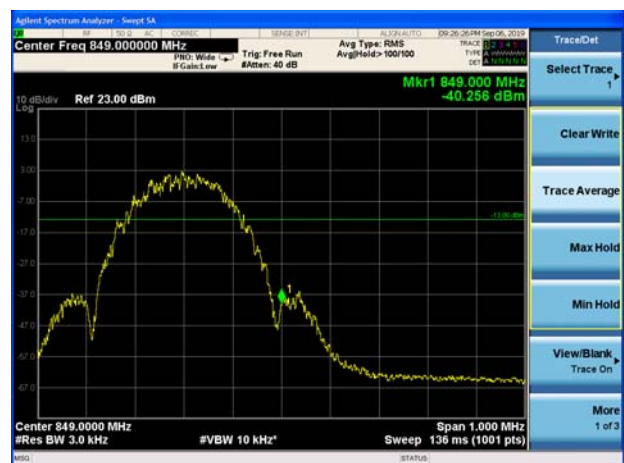



WCDMA Band V CH-Low

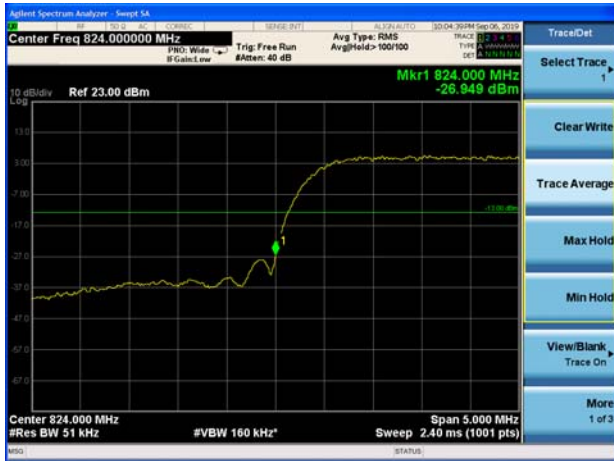

WCDMA Band V CH-High



LTE Band 5 QPSK 1.4MHz CH-Low 1RB

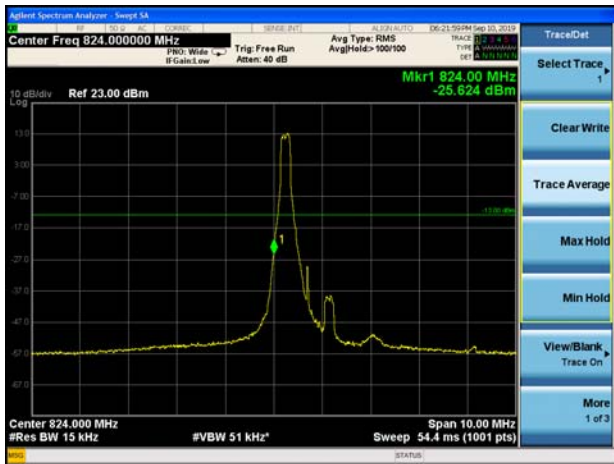

LTE Band 5 QPSK 1.4MHz CH-High 1RB

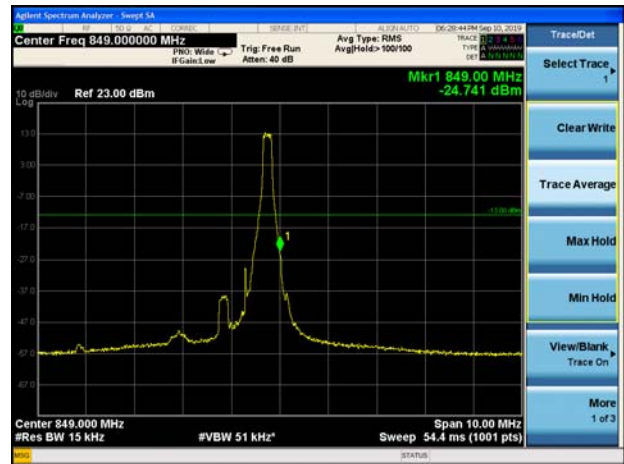

LTE Band 5 QPSK 1.4MHz CH-Low 100%RB

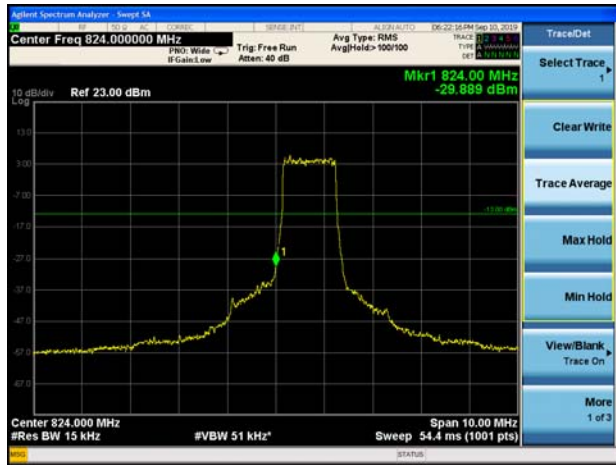

LTE Band 5 QPSK 1.4MHz CH-High 100%RB

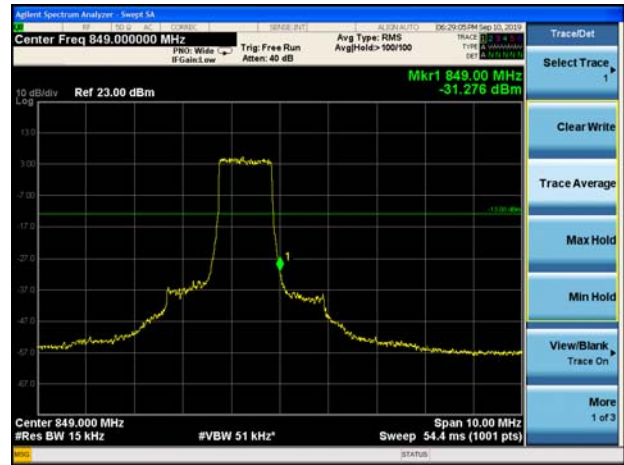

LTE Band 5 QPSK 3MHz CH-Low 1RB

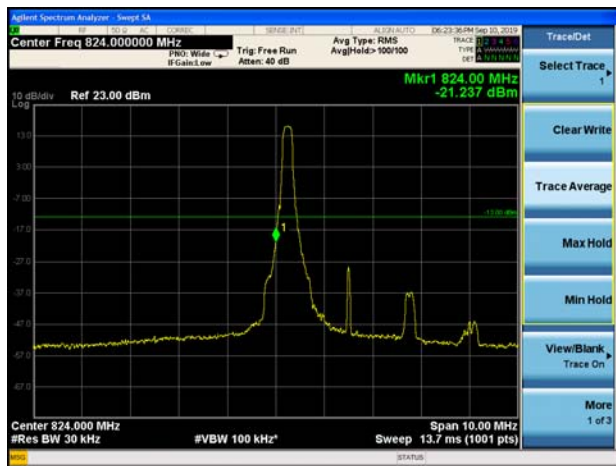

LTE Band 5 QPSK 3MHz CH-High 1RB

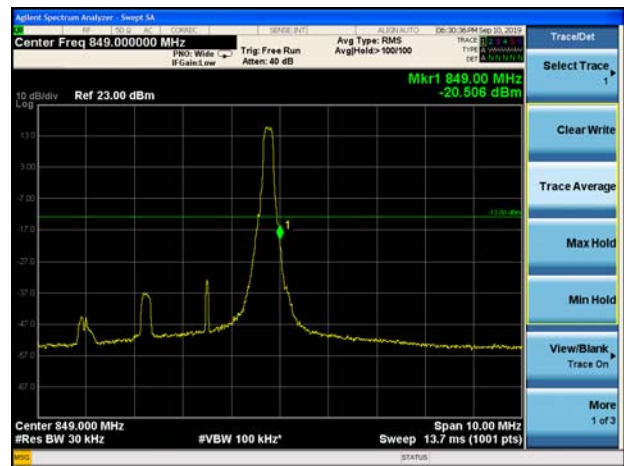

LTE Band 5 QPSK 3MHz CH-Low 100%RB

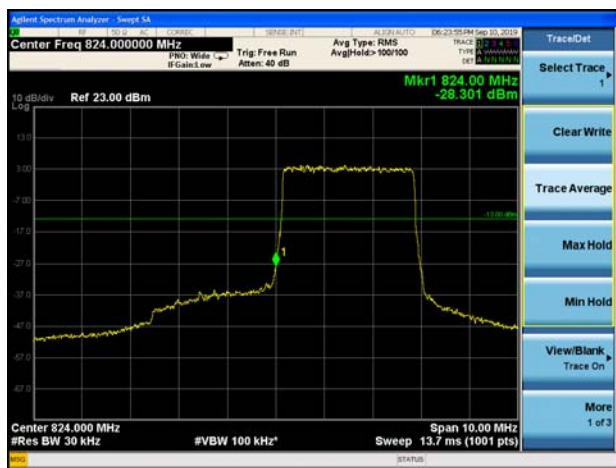

LTE Band 5 QPSK 3MHz CH-High 100%RB

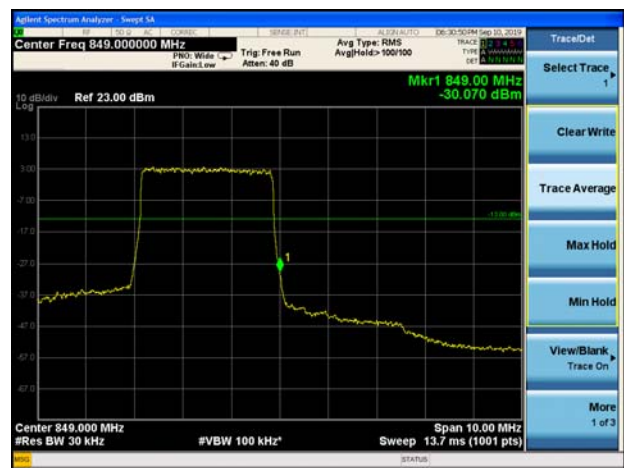



LTE Band 5 QPSK 5MHz CH-Low 1RB

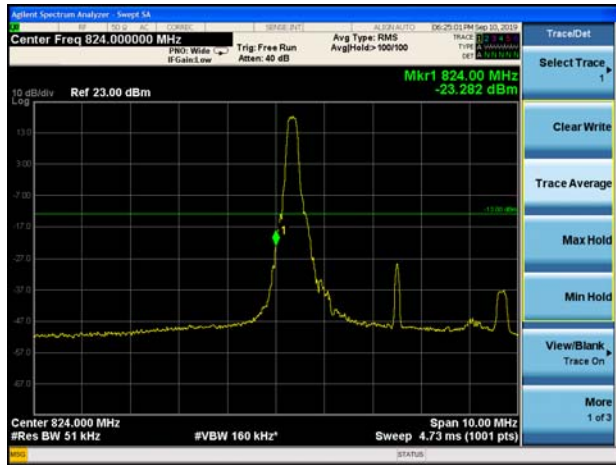

LTE Band 5 QPSK 5MHz CH-High 1RB

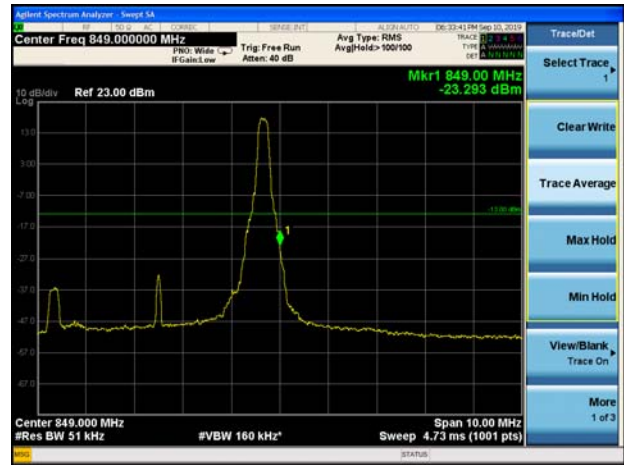

LTE Band 5 QPSK 5MHz CH-Low 100%RB

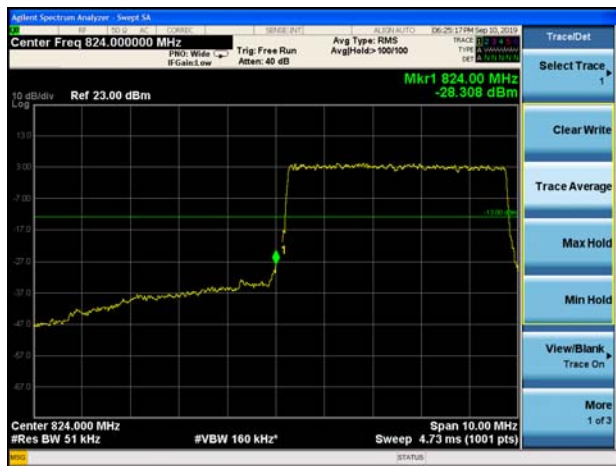

LTE Band 5 QPSK 5MHz CH-High 100%RB



LTE Band 5 QPSK 10MHz CH-Low 1RB

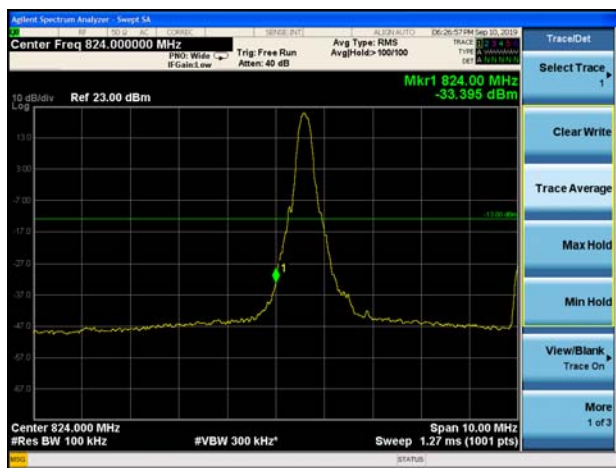

LTE Band 5 QPSK 10MHz CH-High 1RB

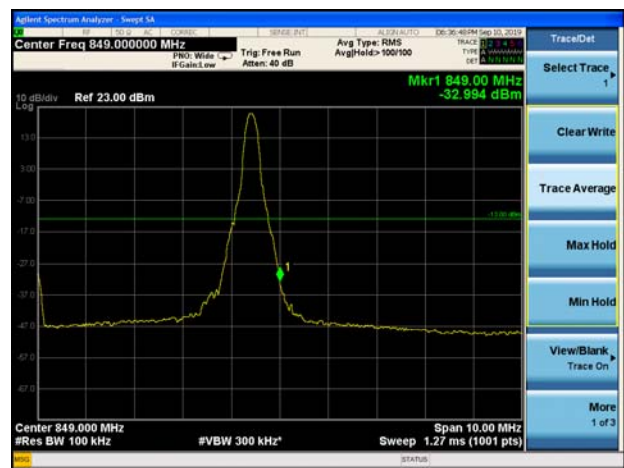

LTE Band 5 QPSK 10MHz CH-Low 100%RB



LTE Band 5 QPSK 10MHz CH-High 100%RB



LTE Band 5 16QAM 1.4MHz CH-Low 1RB

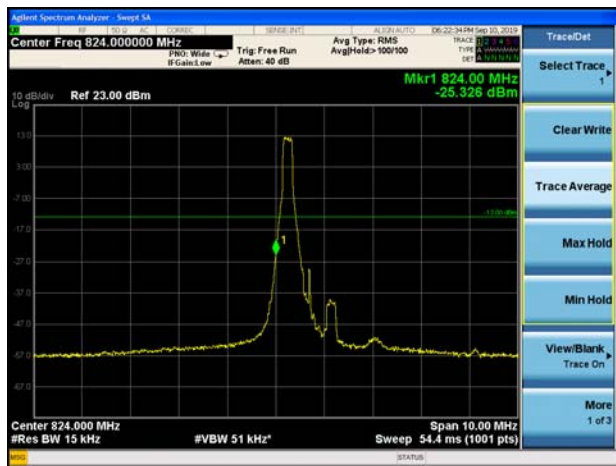

LTE Band 5 16QAM 1.4MHz CH-High 1RB

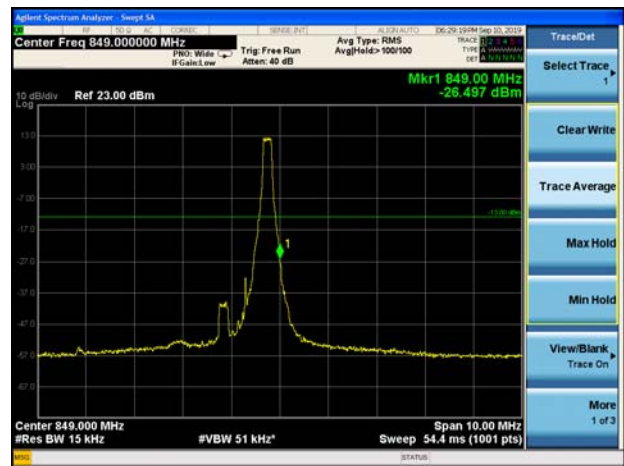

LTE Band 5 16QAM 1.4MHz CH-Low 100%RB

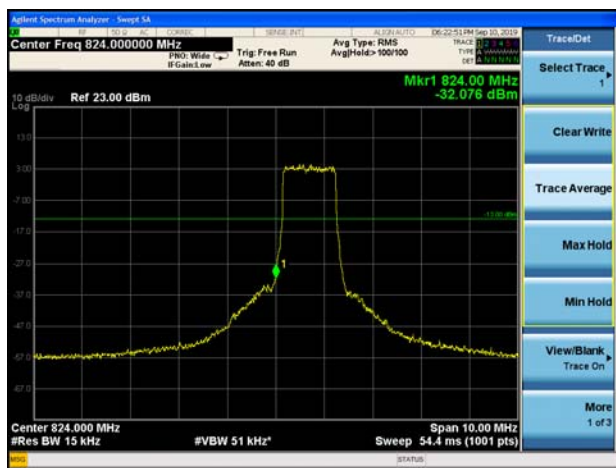

LTE Band 5 16QAM 1.4MHz CH-High 100%RB

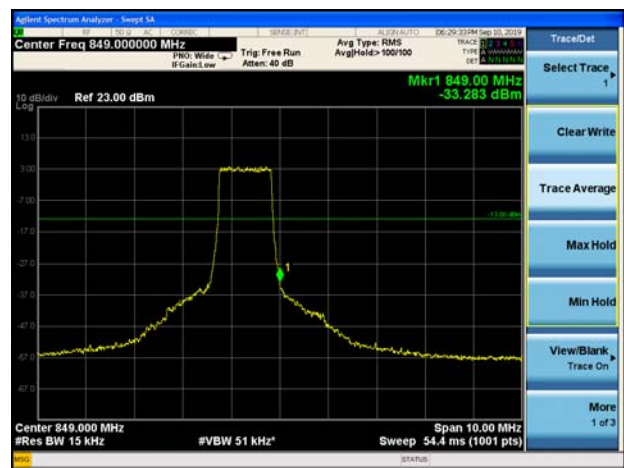

LTE Band 5 16QAM 3MHz CH-Low 1RB

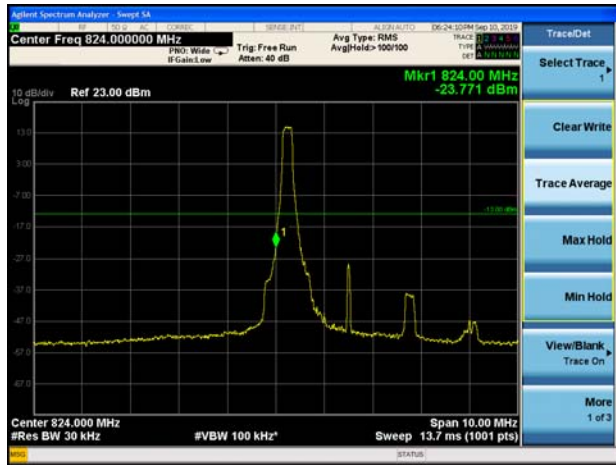

LTE Band 5 16QAM 3MHz CH-High 1RB

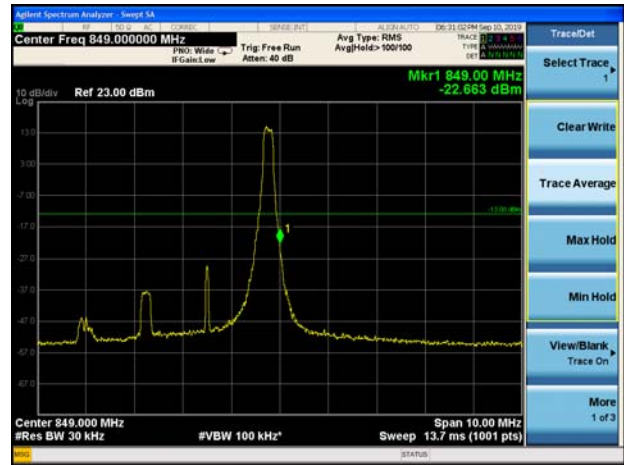

LTE Band 5 16QAM 3MHz CH-Low 100%RB

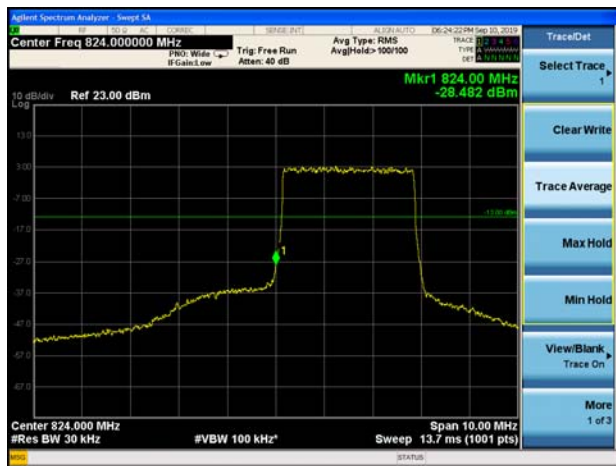

LTE Band 5 16QAM 3MHz CH-High 100%RB

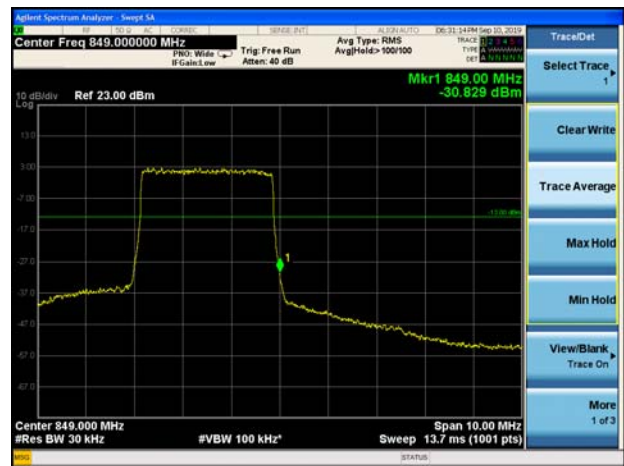

LTE Band 5 16QAM 5MHz CH-Low 1RB

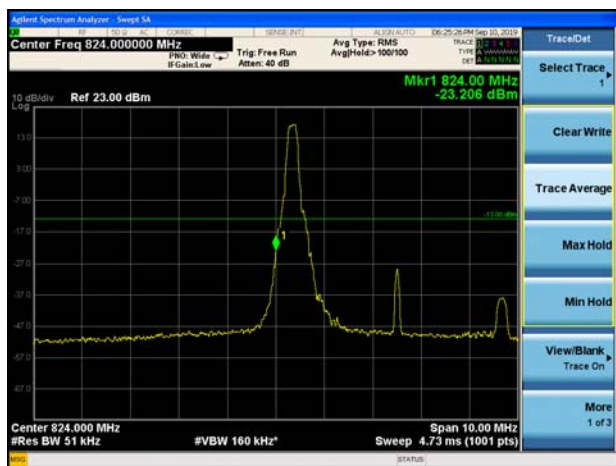

LTE Band 5 16QAM 5MHz CH-High 1RB

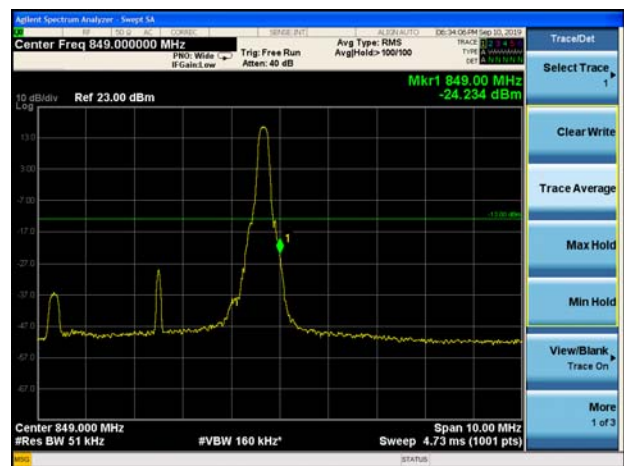



LTE Band 5 16QAM 5MHz CH-Low 100%RB



LTE Band 5 16QAM 5MHz CH-High 100%RB



LTE Band 5 16QAM 10MHz CH-Low 1RB

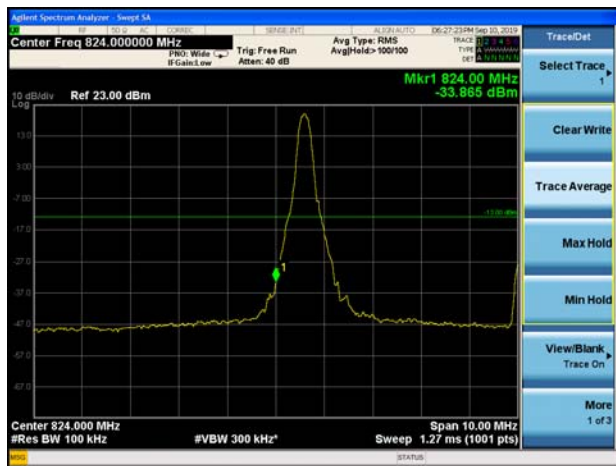

LTE Band 5 16QAM 10MHz CH-High 1RB

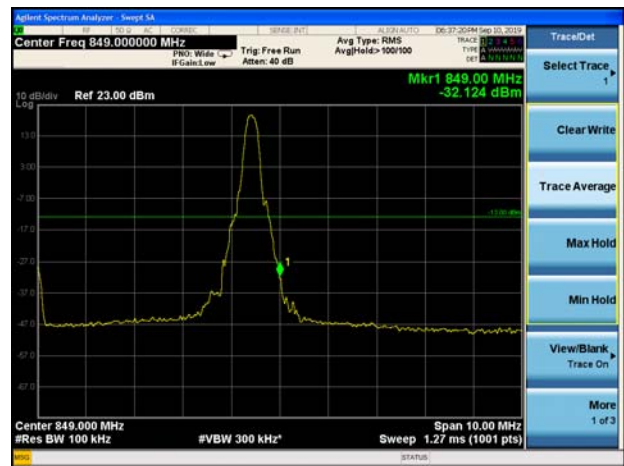

LTE Band 5 16QAM 10MHz CH-Low 100%RB



LTE Band 5 16QAM 10MHz CH-High 100%RB

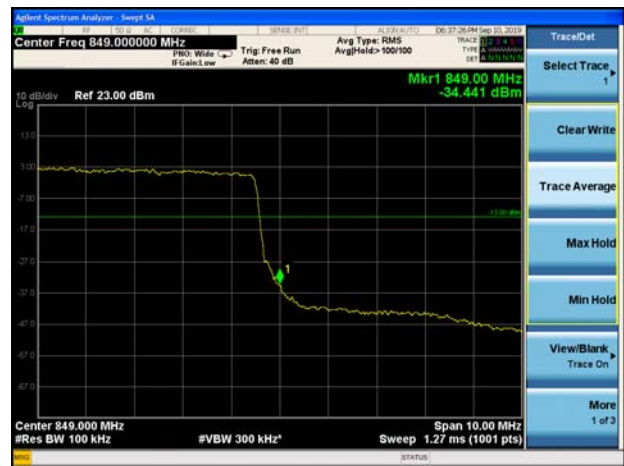



LTE Band 26 QPSK 1.4MHz CH-Low 1RB

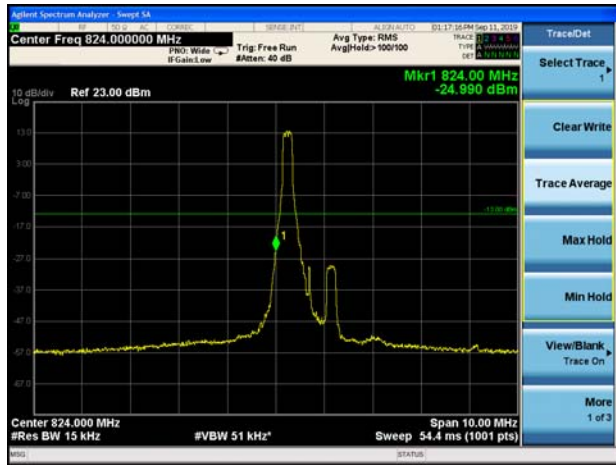

LTE Band 26 QPSK 1.4MHz CH-High 1RB

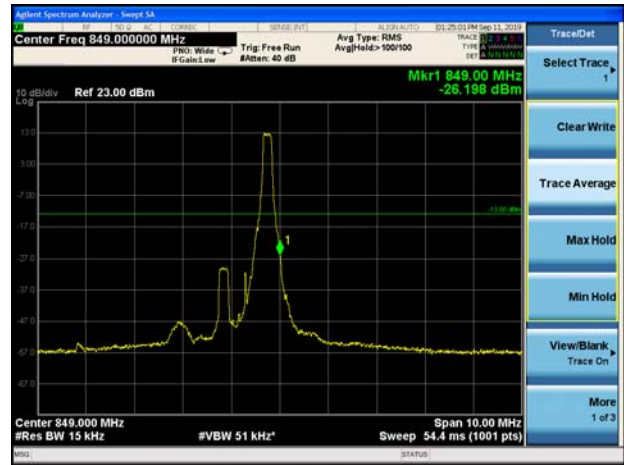

LTE Band 26 QPSK 1.4MHz CH-Low 100%RB

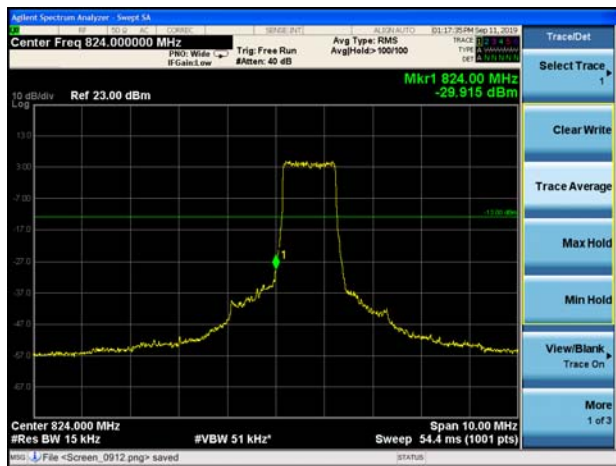

LTE Band 26 QPSK 1.4MHz CH-High 100%RB

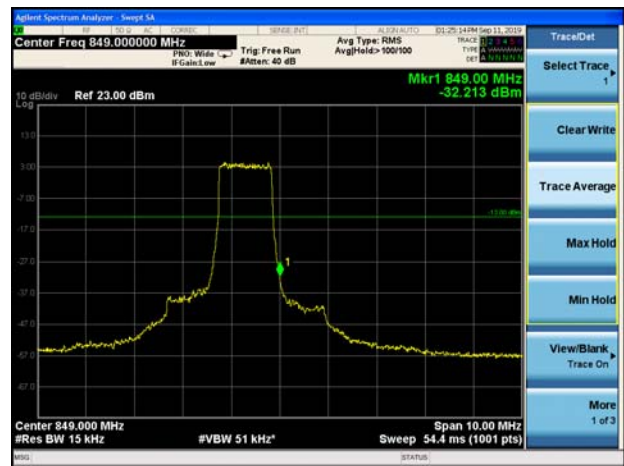

LTE Band 26 QPSK 3MHz CH-Low 1RB

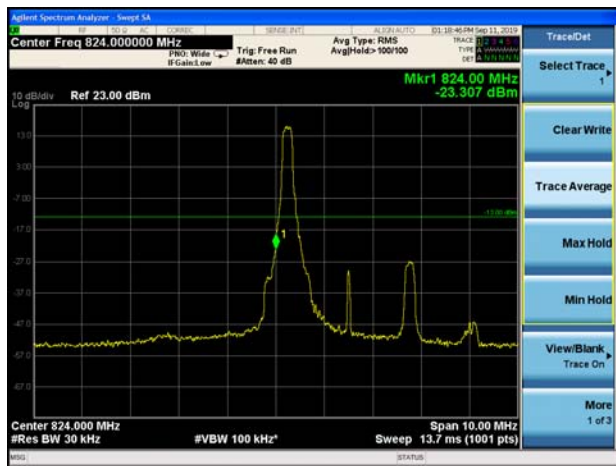

LTE Band 26 QPSK 3MHz CH-High 1RB

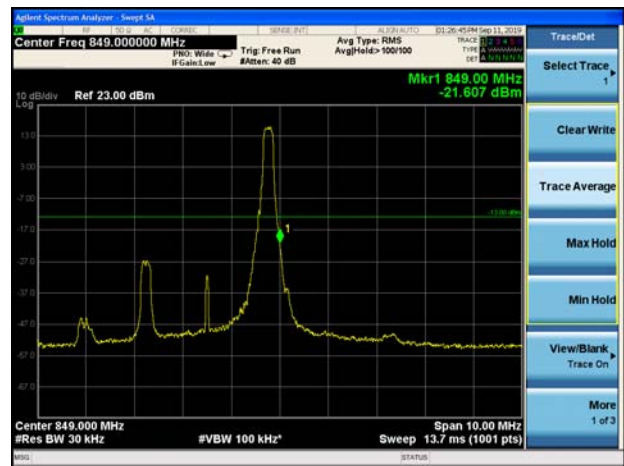



LTE Band 26 QPSK 3MHz CH-Low 100%RB

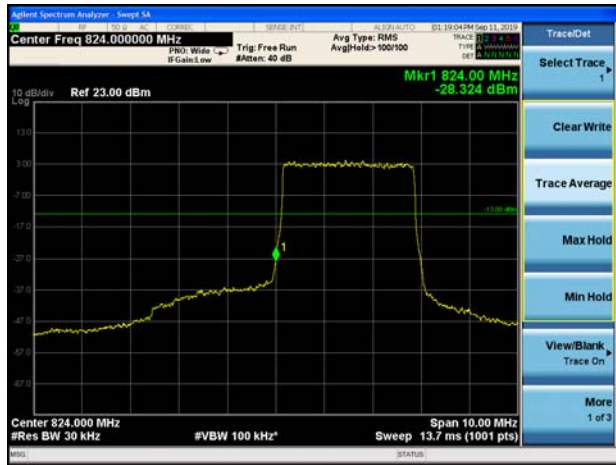

LTE Band 26 QPSK 3MHz CH-High 100%RB



LTE Band 26 QPSK 5MHz CH-Low 1RB

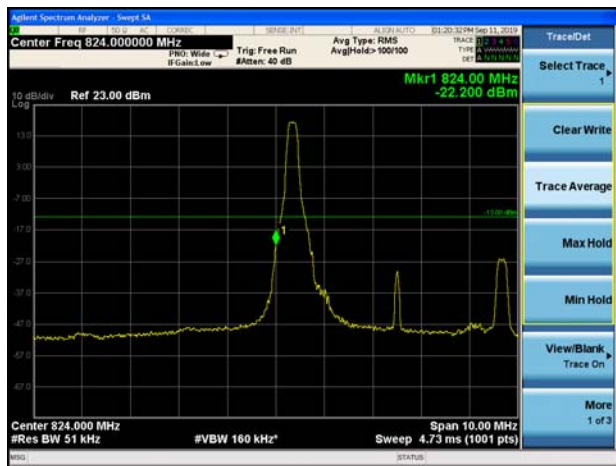

LTE Band 26 QPSK 5MHz CH-High 1RB

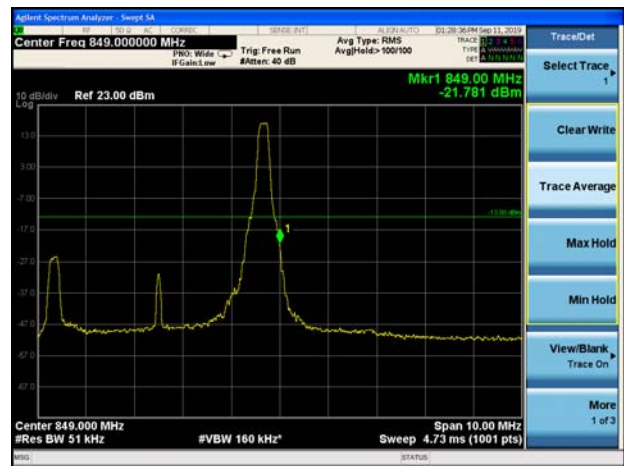

LTE Band 26 QPSK 5MHz CH-Low 100%RB

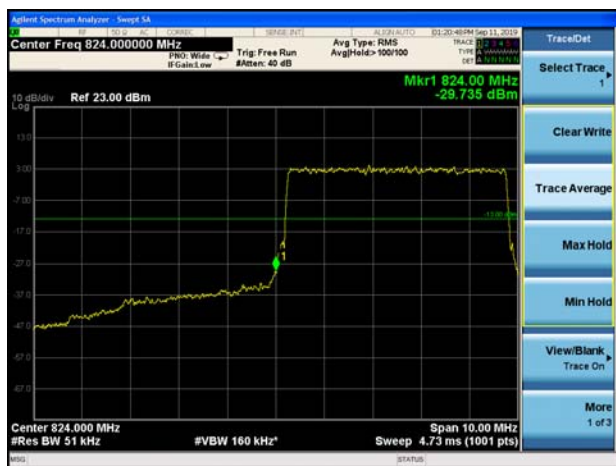

LTE Band 26 QPSK 5MHz CH-High 100%RB





LTE Band 26 QPSK 10MHz CH-Low 1RB

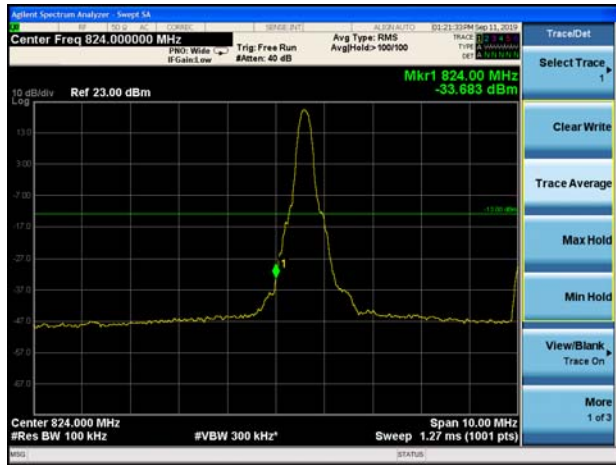

LTE Band 26 QPSK 10MHz CH-High 1RB

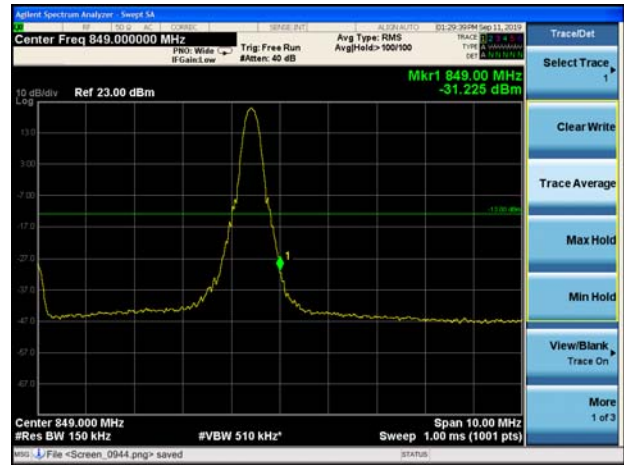

LTE Band 26 QPSK 10MHz CH-Low 100%RB

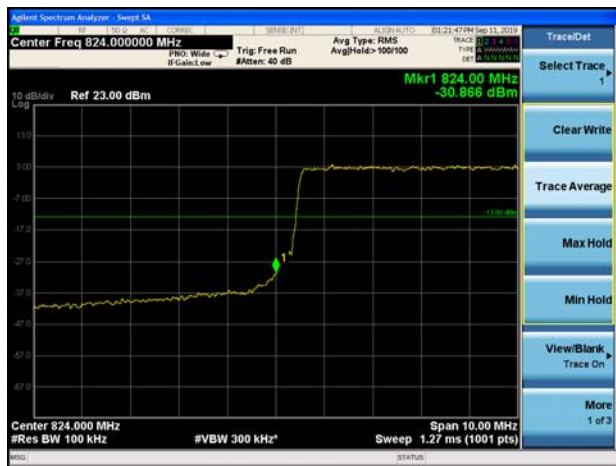

LTE Band 26 QPSK 10MHz CH-High 100%RB

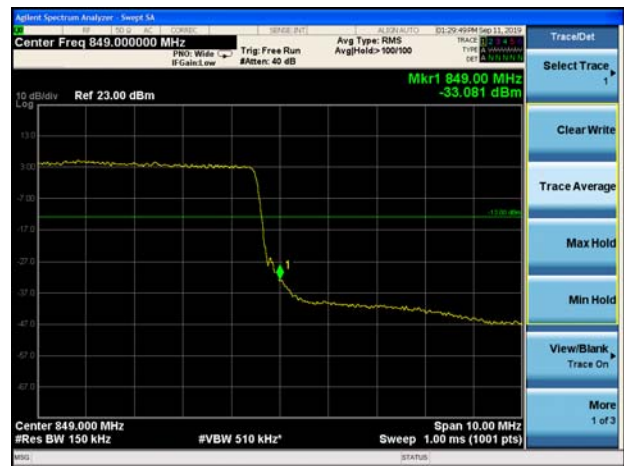

LTE Band 26 QPSK 15MHz CH-Low 1RB

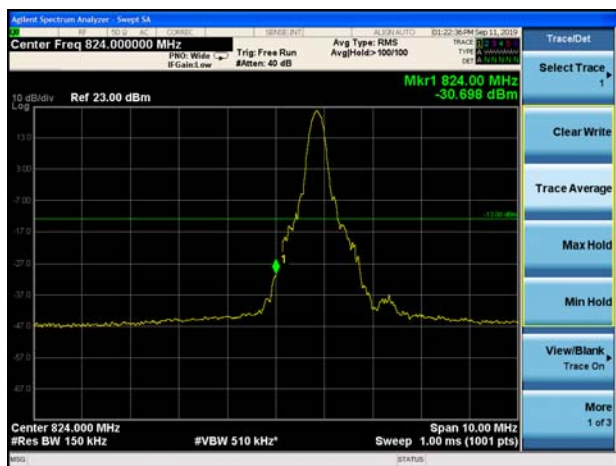

LTE Band 26 QPSK 15MHz CH-High 1RB

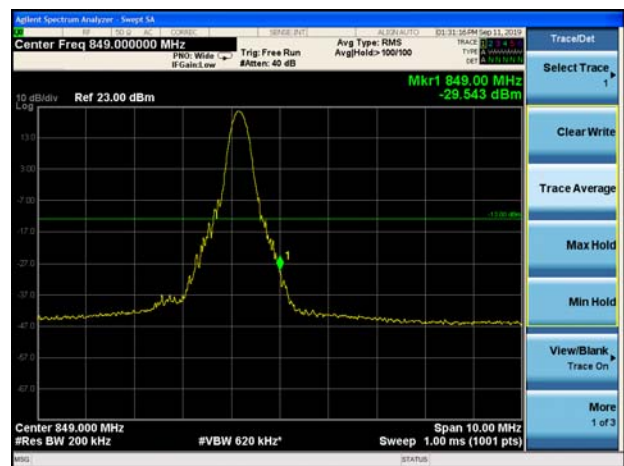



LTE Band 26 QPSK 15MHz CH-Low 100%RB



LTE Band 26 QPSK 15MHz CH-High 100%RB



LTE Band 26 16QAM 1.4MHz CH-Low 1RB

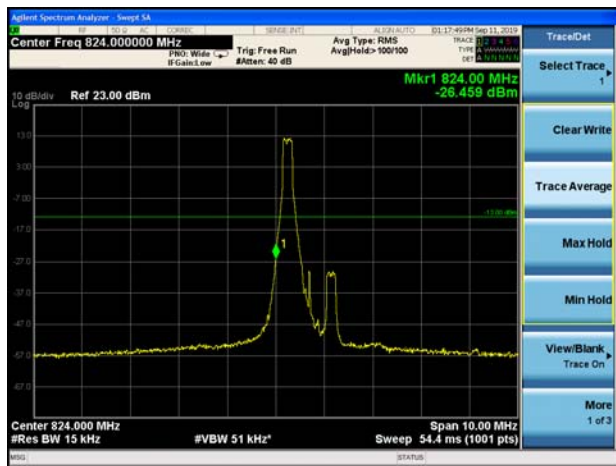

LTE Band 26 16QAM 1.4MHz CH-High 1RB

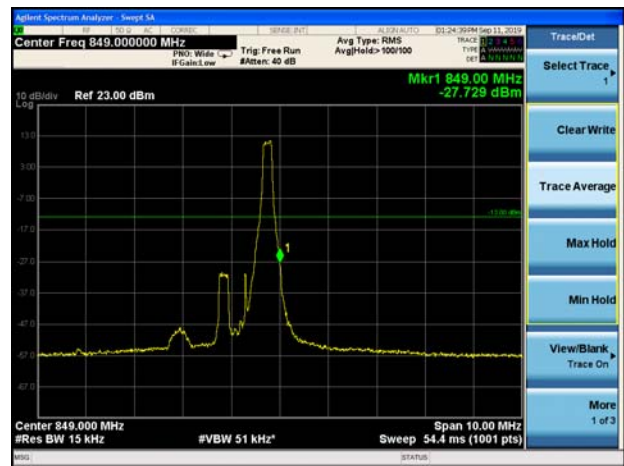

LTE Band 26 16QAM 1.4MHz CH-Low 100%RB

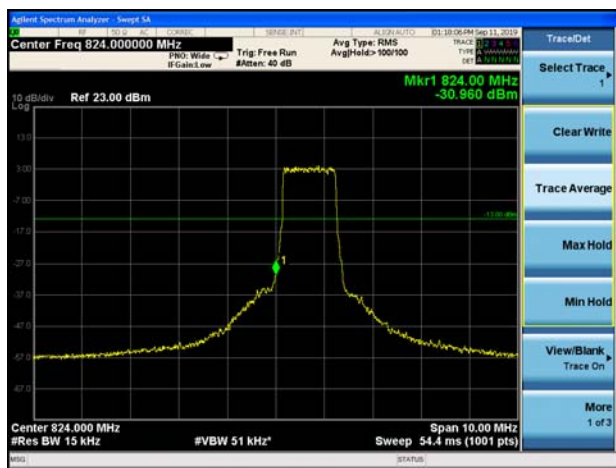

LTE Band 26 16QAM 1.4MHz CH-High 100%RB

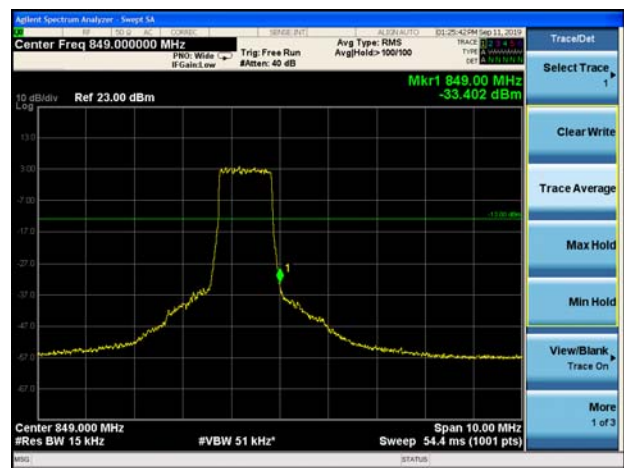



LTE Band 26 16QAM 3MHz CH-Low 1RB

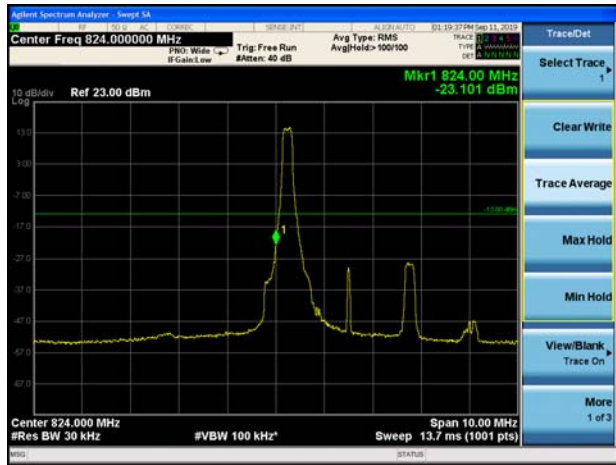

LTE Band 26 16QAM 3MHz CH-High 1RB

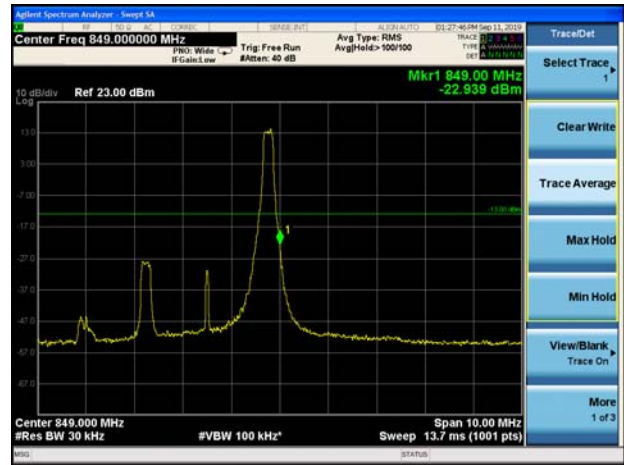

LTE Band 26 16QAM 3MHz CH-Low 100%RB



LTE Band 26 16QAM 3MHz CH-High 100%RB

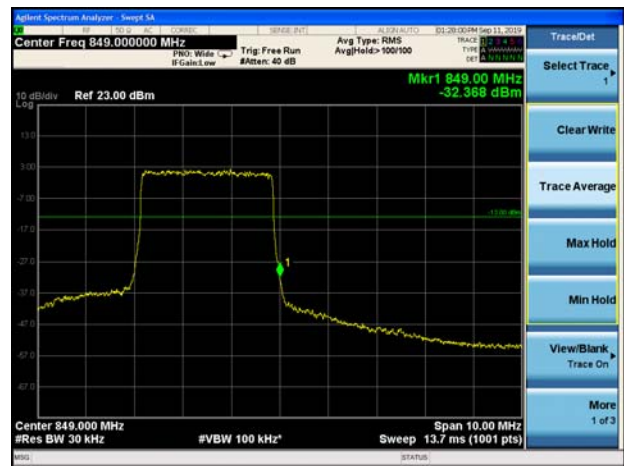

LTE Band 26 16QAM 5MHz CH-Low 1RB

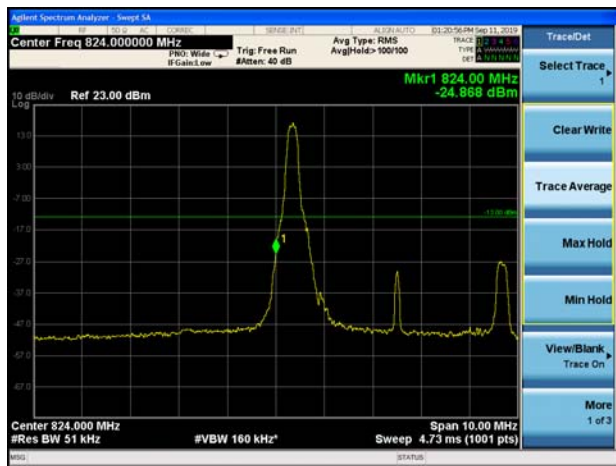

LTE Band 26 16QAM 5MHz CH-High 1RB

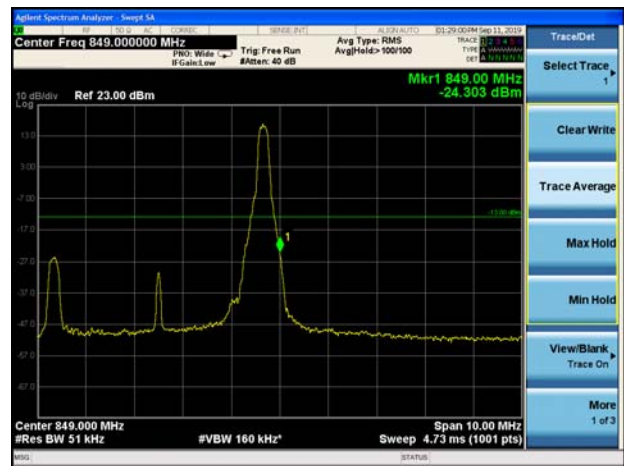

LTE Band 26 16QAM 5MHz CH-Low 100%RB

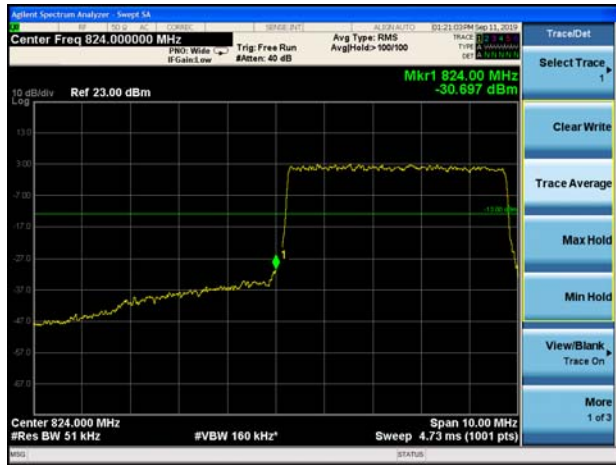

LTE Band 26 16QAM 5MHz CH-High 100%RB



LTE Band 26 16QAM 10MHz CH-Low 1RB

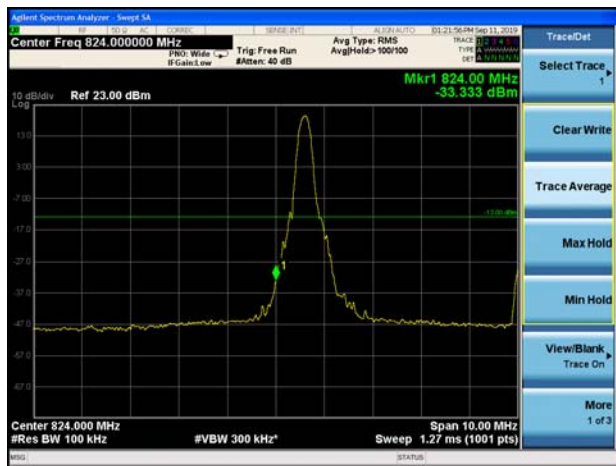

LTE Band 26 16QAM 10MHz CH-High 1RB

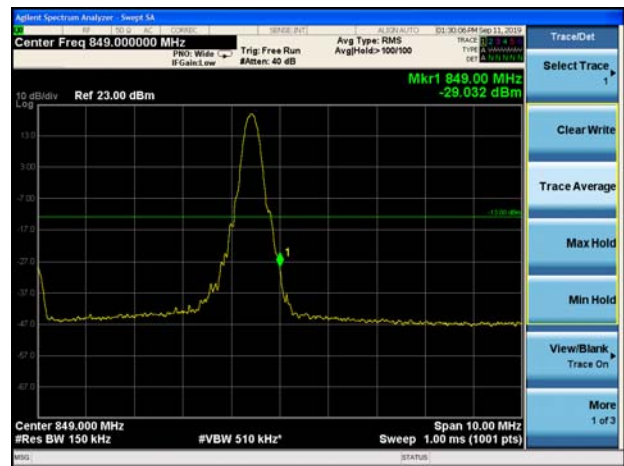

LTE Band 26 16QAM 10MHz CH-Low 100%RB

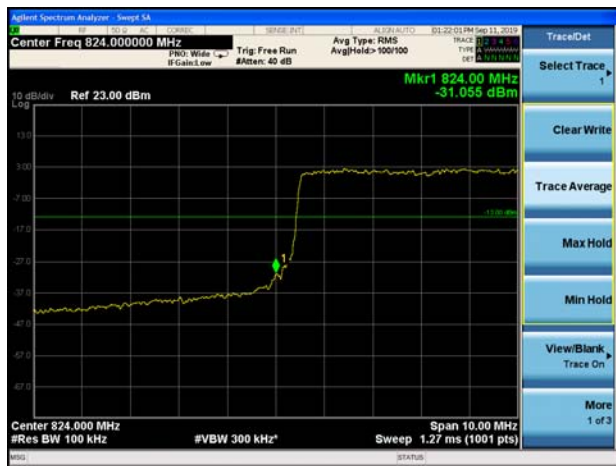

LTE Band 26 16QAM 10MHz CH-High 100%RB





LTE Band 26 16QAM 15MHz CH-Low 1RB

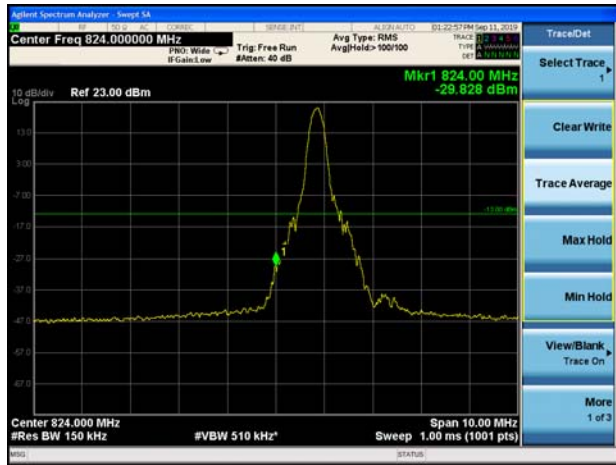

LTE Band 26 16QAM 15MHz CH-High 1RB

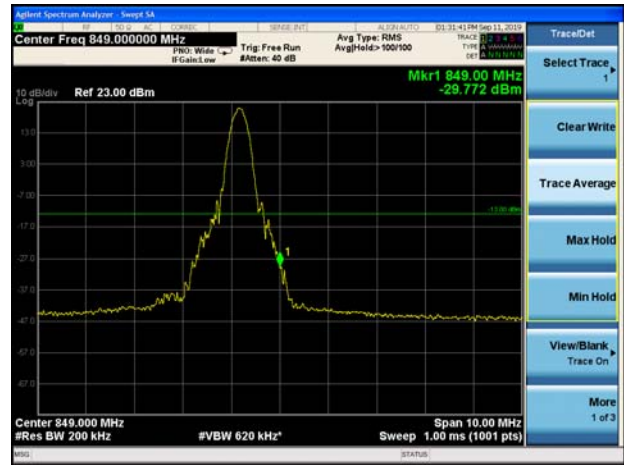

LTE Band 26 16QAM 15MHz CH-Low 100%RB

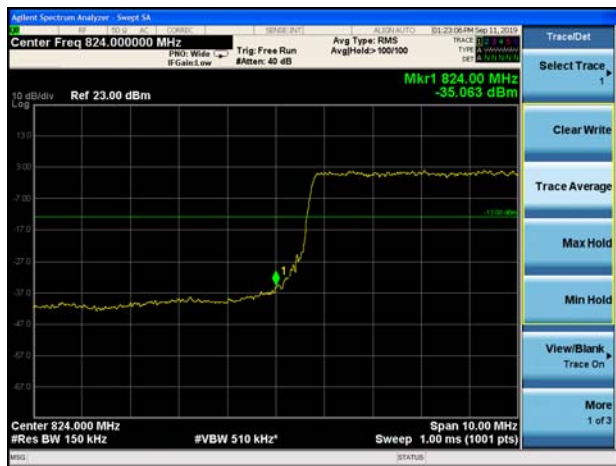

LTE Band 26 16QAM 15MHz CH-High 100%RB



6.4. Peak-to-Average Power Ratio (PAPR)

Mode	Channel	Frequency (MHz)	Peak (dBm)	Avg (dBm)	PAPR (dB)	Limit (dB)	Conclusion
GSM 850 (GSM)	128	824.2	33.50	32.29	1.21	≤13	PASS
	190	836.6	33.66	32.32	1.34	≤13	PASS
	251	848.8	33.59	32.34	1.25	≤13	PASS
GPRS 850 (GMSK)	128	824.2	33.76	32.50	1.26	≤13	PASS
	190	836.6	33.74	32.37	1.37	≤13	PASS
	251	848.8	33.53	32.31	1.22	≤13	PASS
EGPRS 850 (8-PSK)	128	824.2	29.54	27.03	2.51	≤13	PASS
	190	836.6	29.39	27.05	2.34	≤13	PASS
	251	848.8	29.13	26.67	2.46	≤13	PASS
WCDMA Band V (RMC)	4132	826.4	26.11	23.15	2.96	≤13	PASS
	4183	836.6	26.06	23.25	2.81	≤13	PASS
	4233	846.6	26.15	23.22	2.93	≤13	PASS

LTE Band 5								
Modulation	Bandwidth (MHz)	Channel	Frequency (MHz)	Peak (dBm)	Avg (dBm)	PAPR (dB)	Limit (dB)	Conclusion
QPSK	1.4	20407	824.7	27.77	23.28	4.49	≤13	PASS
		20525	836.5	26.89	23.15	3.74	≤13	PASS
		20643	848.3	27.08	23.22	3.86	≤13	PASS
	3	20415	825.5	27.73	23.19	4.54	≤13	PASS
		20525	836.5	26.87	23.21	3.66	≤13	PASS
		20635	847.5	26.94	22.97	3.97	≤13	PASS
	5	20425	826.5	27.43	22.93	4.50	≤13	PASS
		20525	836.5	26.63	22.92	3.71	≤13	PASS
		20625	846.5	27.00	22.75	4.25	≤13	PASS
	10	20450	829	27.93	23.36	4.57	≤13	PASS
		20525	836.5	26.78	22.97	3.81	≤13	PASS
		20600	844	27.24	23.05	4.19	≤13	PASS
16QAM	1.4	20407	824.7	27.94	22.59	5.35	≤13	PASS
		20525	836.5	26.73	22.01	4.72	≤13	PASS
		20643	848.3	27.03	22.36	4.67	≤13	PASS



	3	20415	825.5	27.52	22.11	5.41	≤13	PASS
		20525	836.5	27.01	22.58	4.43	≤13	PASS
		20635	847.5	26.87	21.97	4.90	≤13	PASS
	5	20425	826.5	27.25	21.76	5.49	≤13	PASS
		20525	836.5	26.62	22.14	4.48	≤13	PASS
		20625	846.5	26.90	21.72	5.18	≤13	PASS
	10	20450	829	27.49	22.14	5.35	≤13	PASS
		20525	836.5	26.90	22.54	4.36	≤13	PASS
		20600	844	27.27	22.33	4.94	≤13	PASS



LTE Band 26								
Modulation	Bandwidth (MHz)	Channel	Frequency (MHz)	Peak (dBm)	Avg (dBm)	PAPR (dB)	Limit (dB)	Conclusion
QPSK	1.4	26797	824.7	27.49	22.90	4.59	≤13	PASS
		26915	836.5	26.79	22.99	3.80	≤13	PASS
		27033	848.3	26.84	22.77	4.07	≤13	PASS
	3	26805	825.5	27.52	22.92	4.60	≤13	PASS
		26915	836.5	26.58	22.66	3.92	≤13	PASS
		27025	847.5	26.75	22.64	4.11	≤13	PASS
	5	26815	826.5	27.44	22.88	4.56	≤13	PASS
		26915	836.5	26.59	22.83	3.76	≤13	PASS
		27015	846.5	26.88	22.64	4.24	≤13	PASS
	10	26840	829	27.14	22.74	4.40	≤13	PASS
		26915	836.5	26.58	22.77	3.81	≤13	PASS
		26990	844	27.21	22.87	4.34	≤13	PASS
	15	26865	831.5	27.38	22.90	4.48	≤13	PASS
		26915	836.5	26.69	22.72	3.97	≤13	PASS
		26965	841.5	26.52	22.69	3.83	≤13	PASS
16QAM	1.4	26797	824.7	27.65	22.17	5.48	≤13	PASS
		26915	836.5	26.70	21.81	4.89	≤13	PASS
		27033	848.3	26.76	21.76	5.00	≤13	PASS
	3	26805	825.5	27.22	21.72	5.50	≤13	PASS
		26915	836.5	26.72	22.02	4.70	≤13	PASS
		27025	847.5	26.54	21.45	5.09	≤13	PASS
	5	26815	826.5	27.39	22.07	5.32	≤13	PASS
		26915	836.5	26.59	22.05	4.54	≤13	PASS
		27015	846.5	26.78	21.76	5.02	≤13	PASS
	10	26840	829	27.35	22.28	5.07	≤13	PASS
		26915	836.5	26.39	21.69	4.70	≤13	PASS
		26990	844	26.94	21.56	5.38	≤13	PASS
	15	26865	831.5	27.13	21.64	5.49	≤13	PASS
		26915	836.5	26.91	22.17	4.74	≤13	PASS
		26965	841.5	26.21	21.34	4.87	≤13	PASS

6.5. Frequency Stability

GSM 850						
Condition		Freq.Error (Hz)	Freq.Error (Hz)	Frequency Stability (ppm)	Frequency Stability (ppm)	Verdict
Temperature	Voltage	GMSK	8PSK	GMSK	8PSK	
Normal (25°C)	Normal	13.63	3.69	0.00725	0.00197	PASS
Extreme (90°C)		11.29	16.37	0.00601	0.00871	PASS
Extreme (80°C)		4.20	4.87	0.00224	0.00259	PASS
Extreme (70°C)		14.13	12.46	0.00752	0.00663	PASS
Extreme (60°C)		6.13	11.70	0.00326	0.00622	PASS
Extreme (50°C)		15.87	16.25	0.00844	0.00864	PASS
Extreme (40°C)		6.13	6.09	0.00326	0.00324	PASS
Extreme (30°C)		11.96	10.57	0.00636	0.00562	PASS
Extreme (20°C)		4.01	8.65	0.00213	0.00460	PASS
Extreme (10°C)		4.31	7.09	0.00229	0.00377	PASS
Extreme (0°C)		10.50	14.56	0.00558	0.00774	PASS
Extreme (-10°C)		10.47	11.23	0.00557	0.00598	PASS
Extreme (-20°C)		7.55	11.67	0.00402	0.00621	PASS
Extreme (-30°C)		9.23	11.12	0.00491	0.00591	PASS
Extreme (-40°C)		14.52	10.13	0.00772	0.00539	PASS
25°C	LV	10.74	9.70	0.00571	0.00516	PASS
	HV	16.93	16.84	0.00900	0.00896	PASS

WCDMA Band 5						
Condition		Freq.Error (Hz)	Freq.Error (Hz)	Frequency Stability (ppm)	Frequency Stability (ppm)	Verdict
Temperature	Voltage	BPSK	QPSK	BPSK	QPSK	
Normal (25°C)	Normal	9.95	9.30	0.00529	0.00495	PASS
Extreme (90°C)		13.53	10.00	0.00720	0.00532	PASS
Extreme (80°C)		16.30	9.78	0.00867	0.00520	PASS
Extreme (70°C)		2.67	8.67	0.00142	0.00461	PASS
Extreme (60°C)		12.29	9.27	0.00654	0.00493	PASS
Extreme (50°C)		11.52	16.55	0.00613	0.00880	PASS
Extreme (40°C)		3.13	10.30	0.00167	0.00548	PASS
Extreme (30°C)		8.41	11.75	0.00447	0.00625	PASS
Extreme (20°C)		16.19	9.40	0.00861	0.00500	PASS
Extreme (10°C)		17.28	1.85	0.00919	0.00098	PASS
Extreme (0°C)		3.63	5.34	0.00193	0.00284	PASS
Extreme (-10°C)		12.89	10.40	0.00686	0.00553	PASS
Extreme (-20°C)		2.66	6.02	0.00142	0.00320	PASS
Extreme (-30°C)		8.48	5.85	0.00451	0.00311	PASS
Extreme (-40°C)		14.86	2.07	0.00790	0.00110	PASS
25°C	LV	10.07	6.55	0.00536	0.00348	PASS
	HV	12.19	9.89	0.00648	0.00526	PASS



LTE Band 5						
Condition		Freq.Error (Hz)	Freq.Error (Hz)	Frequency Stability (ppm)	Frequency Stability (ppm)	Verdict
BANDWIDTH	10MHz					
Temperature	Voltage	16QAM	QPSK	16QAM	QPSK	
Normal (25°C)	Normal	13.27	11.76	0.00706	0.00626	PASS
Extreme (90°C)		11.64	13.12	0.00619	0.00698	PASS
Extreme (80°C)		5.04	6.41	0.00268	0.00341	PASS
Extreme (70°C)		16.22	14.51	0.00863	0.00772	PASS
Extreme (60°C)		4.22	11.96	0.00225	0.00636	PASS
Extreme (50°C)		3.82	15.41	0.00203	0.00820	PASS
Extreme (40°C)		6.80	2.19	0.00362	0.00117	PASS
Extreme (30°C)		7.17	9.65	0.00382	0.00513	PASS
Extreme (20°C)		13.91	12.76	0.00740	0.00679	PASS
Extreme (10°C)		7.98	14.59	0.00424	0.00776	PASS
Extreme (0°C)		4.62	11.39	0.00246	0.00606	PASS
Extreme (-10°C)		4.91	17.28	0.00261	0.00919	PASS
Extreme (-20°C)		10.44	12.99	0.00555	0.00691	PASS
Extreme (-30°C)		15.36	8.57	0.00817	0.00456	PASS
Extreme (-40°C)		16.36	2.48	0.00870	0.00132	PASS
25°C	LV	16.50	16.96	0.00878	0.00902	PASS
	HV	5.83	13.55	0.00310	0.00721	PASS



LTE Band 26						
Condition		Freq.Error (Hz)	Freq.Error (Hz)	Frequency Stability (ppm)	Frequency Stability (ppm)	Verdict
BANDWIDTH	10MHz					
Temperature	Voltage	16QAM	QPSK	16QAM	QPSK	
Normal (25°C)	Normal	1.74	6.76	0.00093	0.00360	PASS
Extreme (90°C)		16.00	5.71	0.00851	0.00304	PASS
Extreme (80°C)		12.95	13.87	0.00689	0.00738	PASS
Extreme (70°C)		3.93	6.39	0.00209	0.00340	PASS
Extreme (60°C)		11.54	14.44	0.00614	0.00768	PASS
Extreme (50°C)		17.97	9.75	0.00956	0.00518	PASS
Extreme (40°C)		2.90	3.83	0.00154	0.00204	PASS
Extreme (30°C)		15.04	13.56	0.00800	0.00721	PASS
Extreme (20°C)		1.65	12.79	0.00088	0.00680	PASS
Extreme (10°C)		14.02	7.44	0.00746	0.00395	PASS
Extreme (0°C)		2.61	15.90	0.00139	0.00846	PASS
Extreme (-10°C)		13.92	16.25	0.00740	0.00865	PASS
Extreme (-20°C)		12.52	15.13	0.00666	0.00805	PASS
Extreme (-30°C)		14.37	8.32	0.00765	0.00442	PASS
Extreme (-40°C)		11.43	2.41	0.00608	0.00128	PASS
25°C	LV	8.88	14.48	0.00473	0.00770	PASS
	HV	17.31	11.13	0.00921	0.00592	PASS



6.6. Spurious Emissions at Antenna Terminals

Sweep the whole frequency band through the range from 9kHz to the 10th harmonic of the carrier, the emissions more than 20 dB below the limit are not reported.

The signal beyond the limit is carrier.

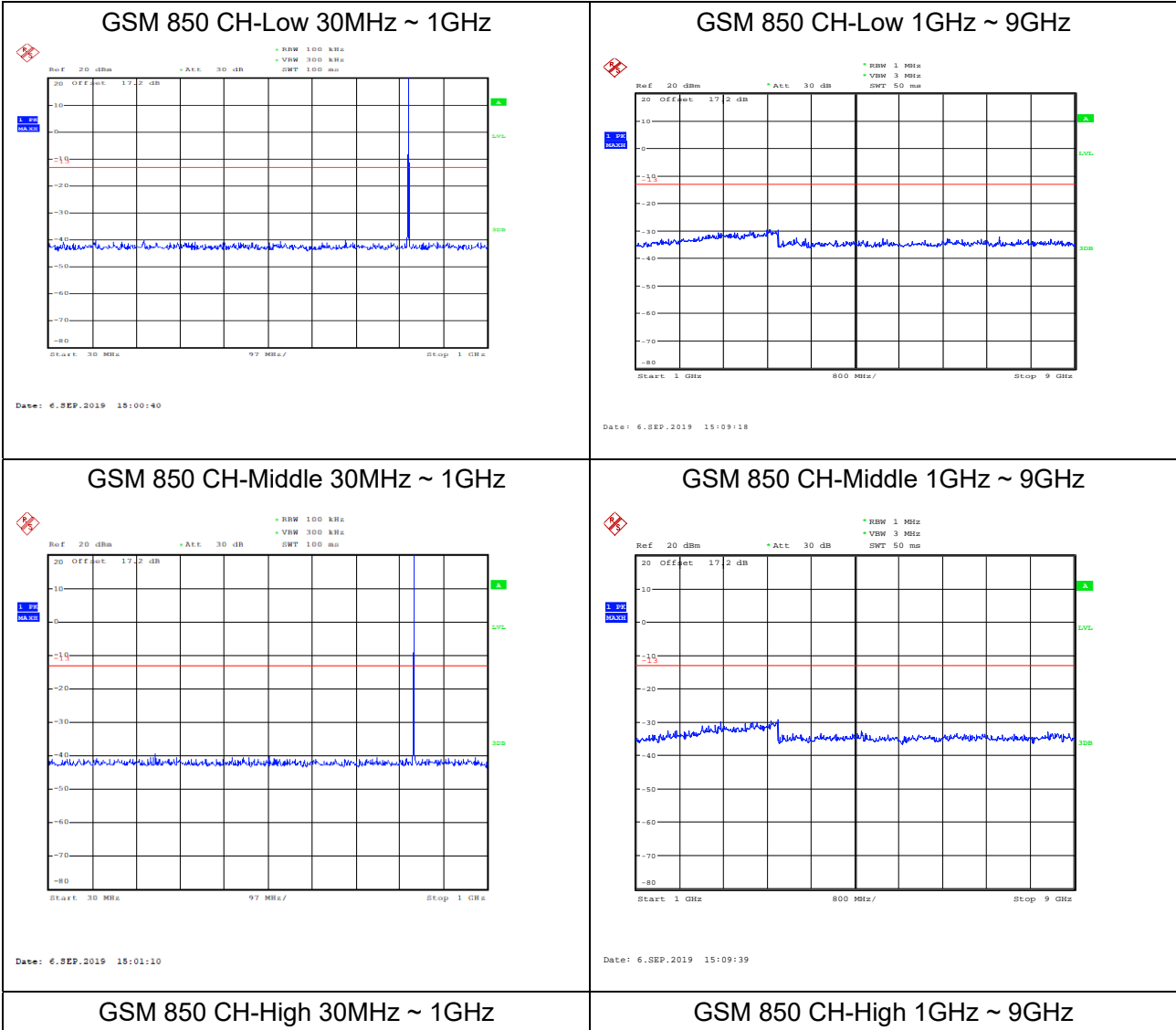

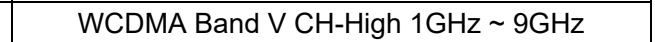
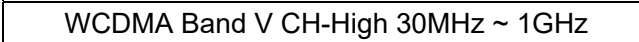
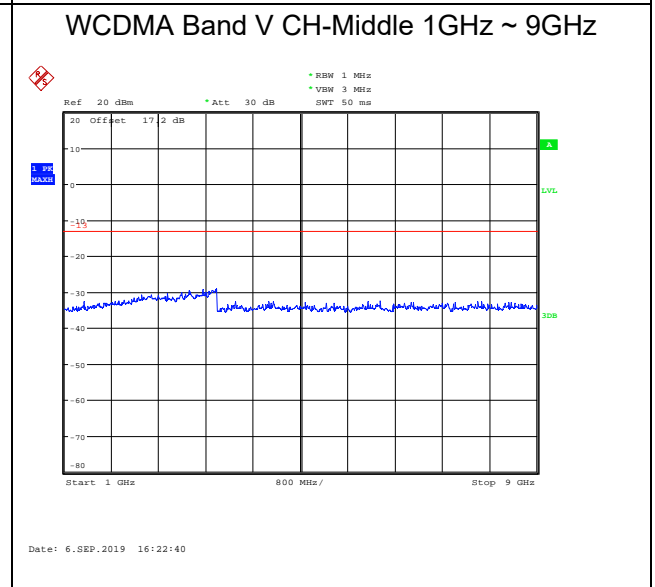
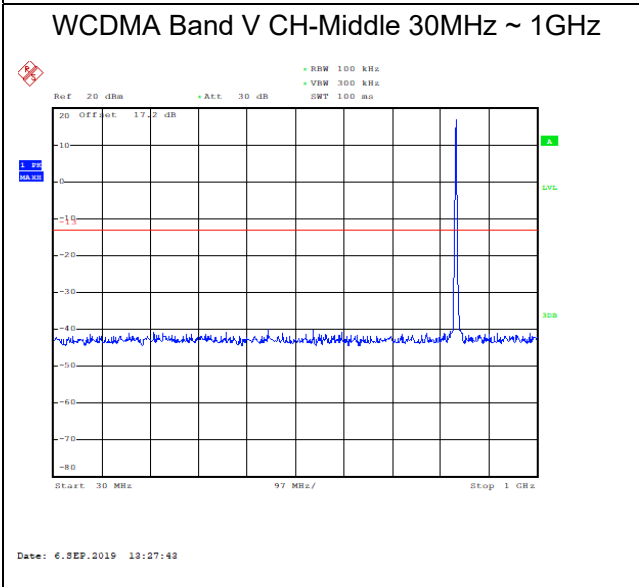
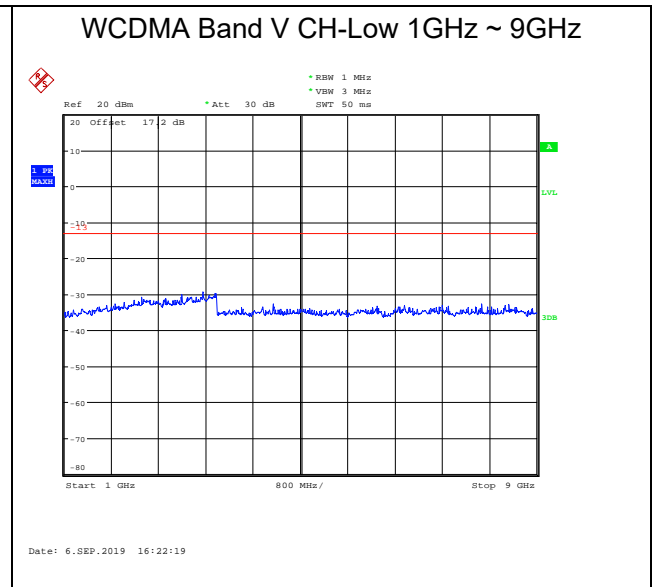
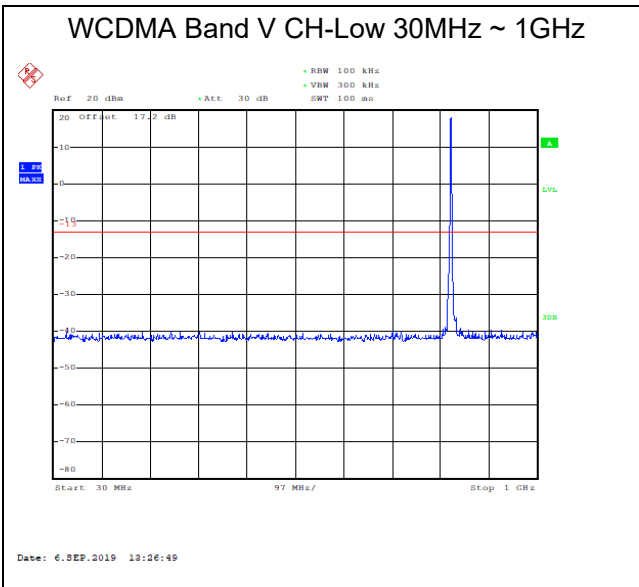
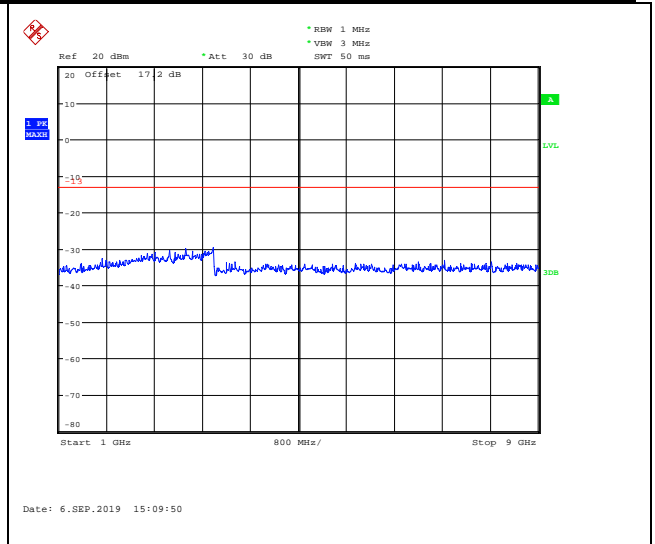
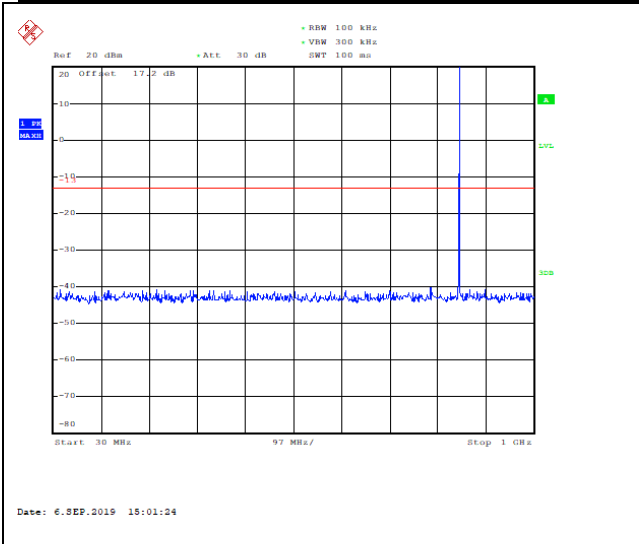

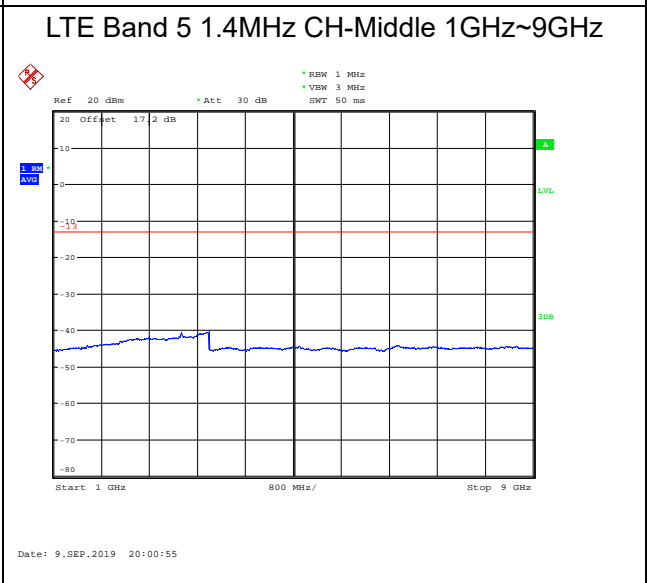
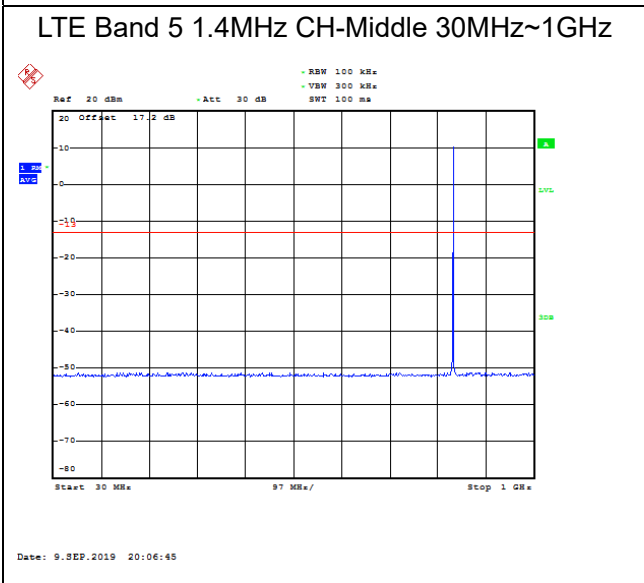
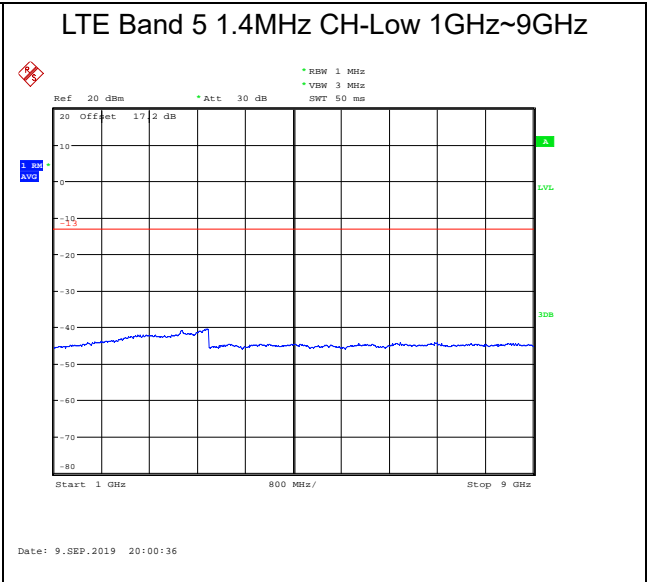
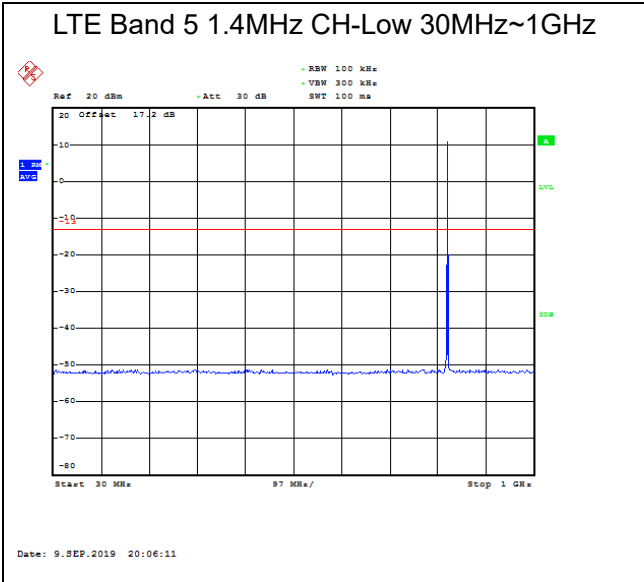
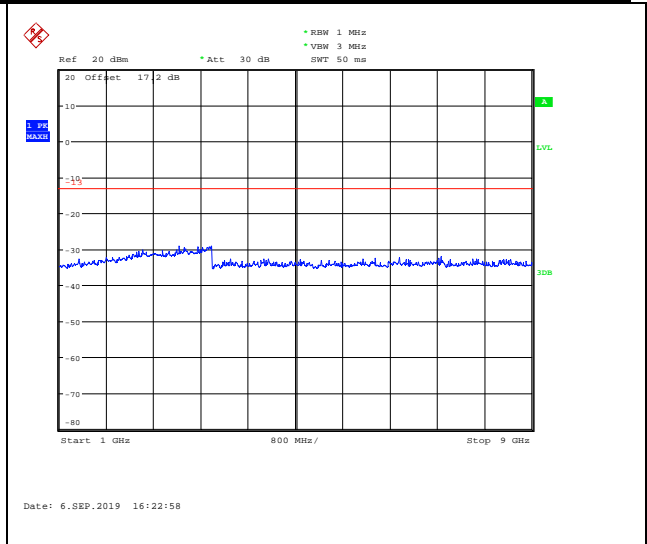
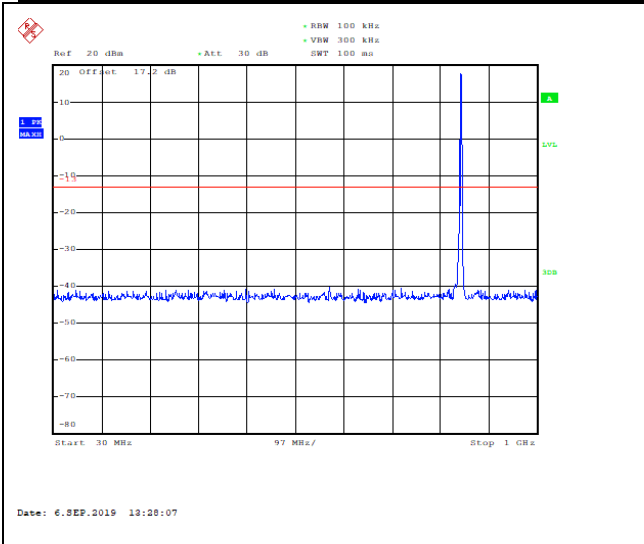



LTE Band 5 1.4MHz CH-High 30MHz~1GHz

LTE Band 5 1.4MHz CH-High 1GHz~9GHz

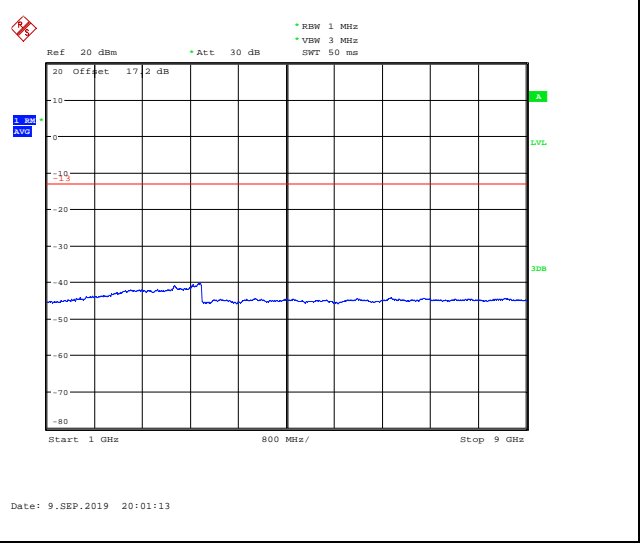
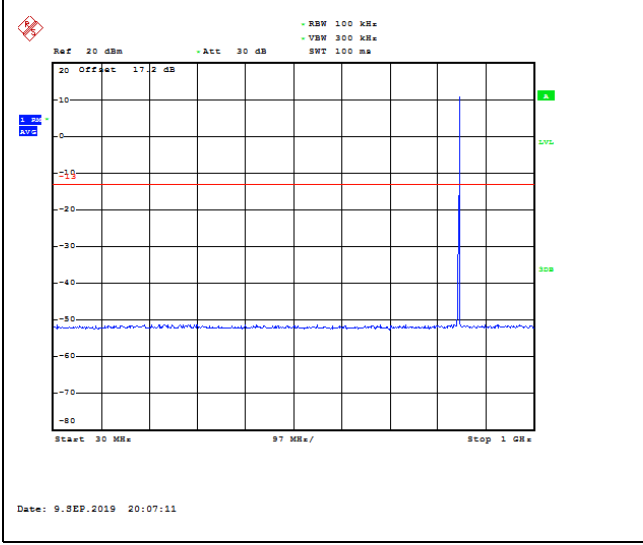



LTE Band 5 3MHz CH-Low 30MHz~1GHz

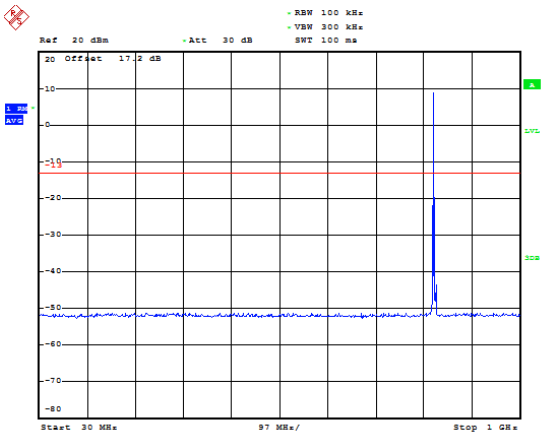

Date: 9.SEP.2019 20:07:57

LTE Band 5 3MHz CH-Low 1GHz~9GHz

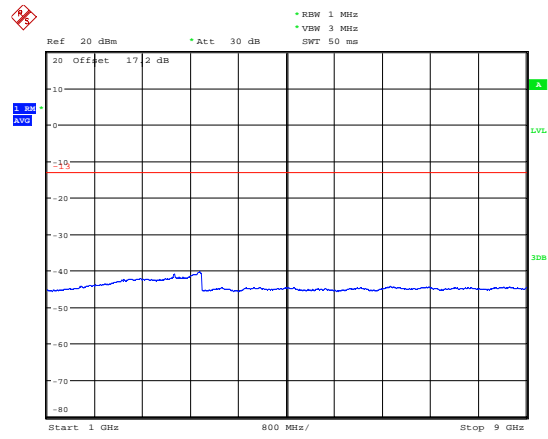

Date: 9.SEP.2019 20:01:56

LTE Band 5 3MHz CH-Middle 30MHz~1GHz

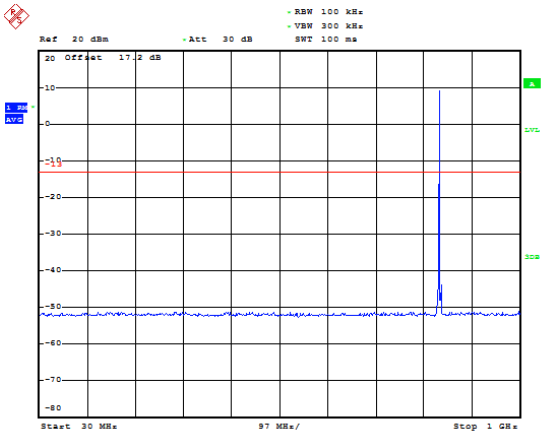

Date: 9.SEP.2019 20:08:19

LTE Band 5 3MHz CH-Middle 1GHz~9GHz

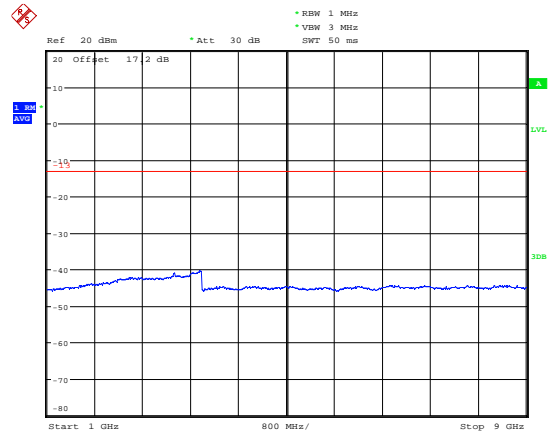

Date: 9.SEP.2019 20:02:14

LTE Band 5 3MHz CH-High 30MHz~1GHz

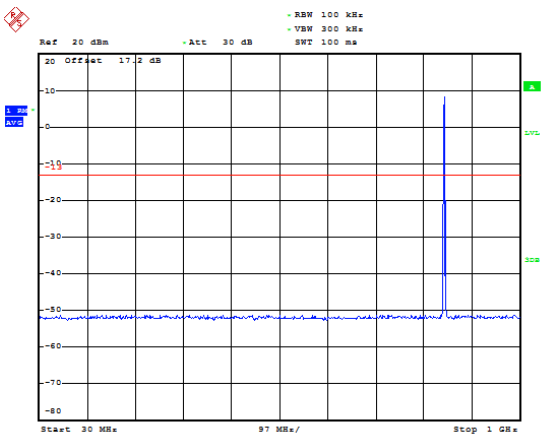

Date: 9.SEP.2019 20:08:02

LTE Band 5 3MHz CH-High 1GHz~9GHz

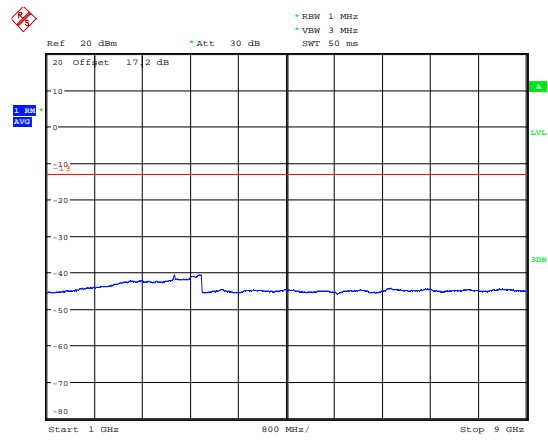

Date: 9.SEP.2019 20:02:35



LTE Band 5 5MHz CH-Low 30MHz~1GHz

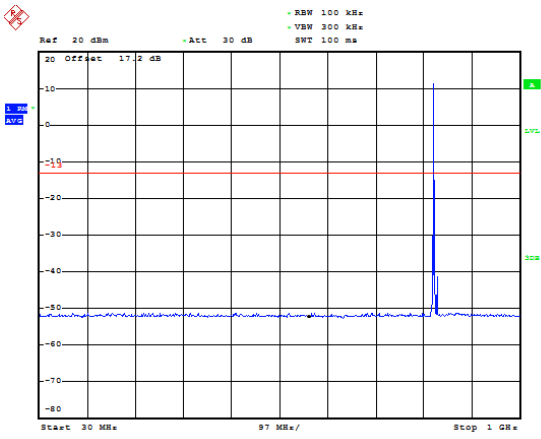

Date: 9.SEP.2019 20:08:52

LTE Band 5 5MHz CH-Low 1GHz~9GHz

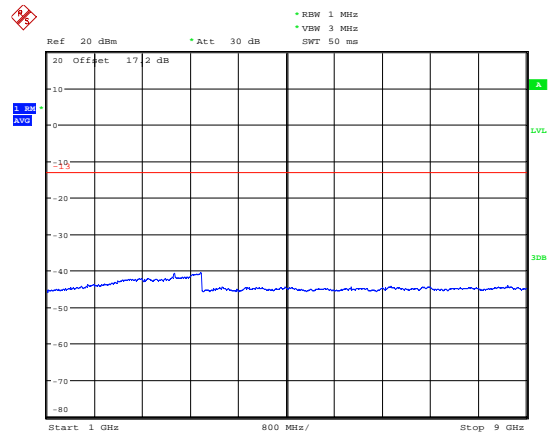

Date: 9.SEP.2019 20:03:05

LTE Band 5 5MHz CH-Middle 30MHz~1GHz

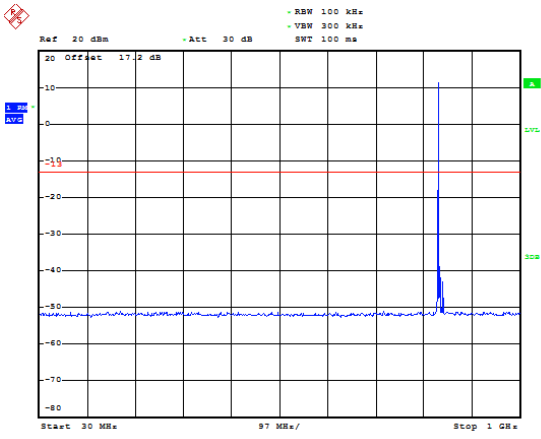

Date: 9.SEP.2019 20:09:05

LTE Band 5 5MHz CH-Middle 1GHz~9GHz

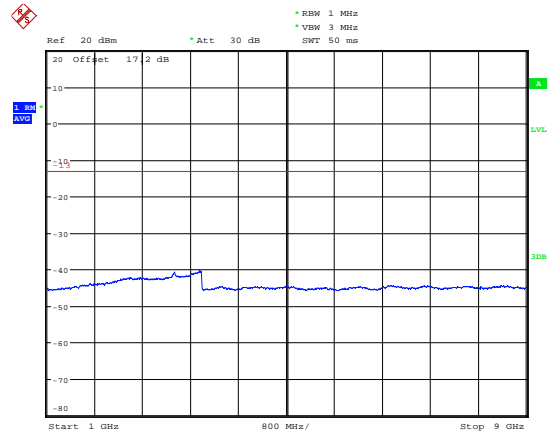

Date: 9.SEP.2019 20:03:22

LTE Band 5 5MHz CH-High 30MHz~1GHz

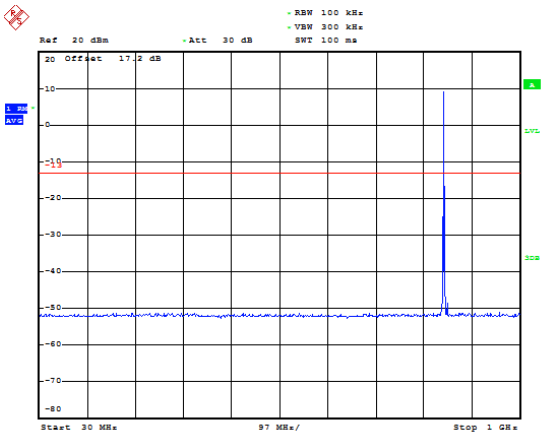

Date: 9.SEP.2019 20:09:24

LTE Band 5 5MHz CH-High 1GHz~9GHz

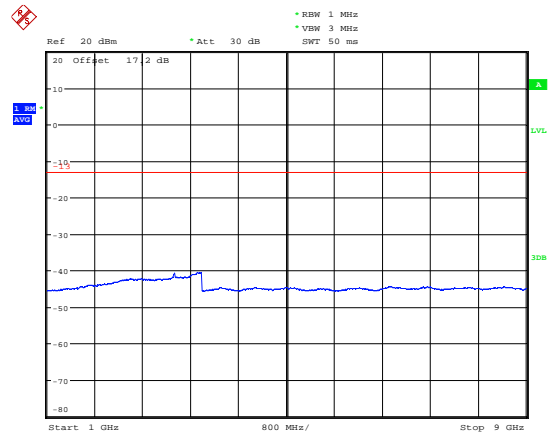

Date: 9.SEP.2019 20:03:49



LTE Band 5 10MHz CH-Low 30MHz~1GHz

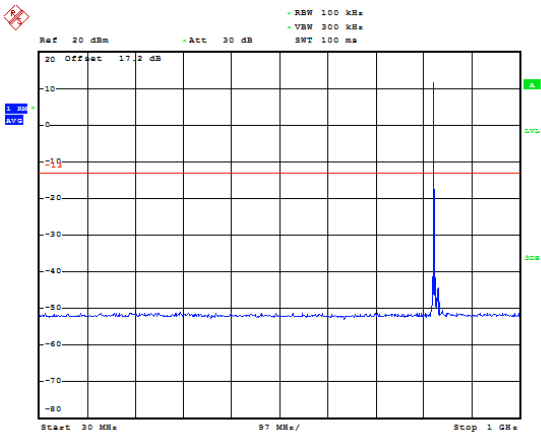

Date: 9.SEP.2019 20:09:45

LTE Band 5 10MHz CH-Low 1GHz~9GHz

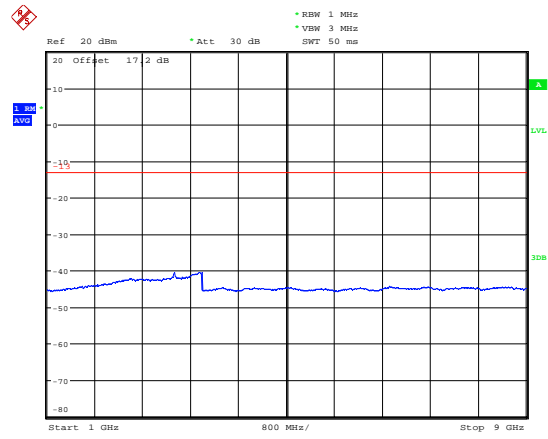

Date: 9.SEP.2019 20:04:14

LTE Band 5 10MHz CH-Middle 30MHz~1GHz

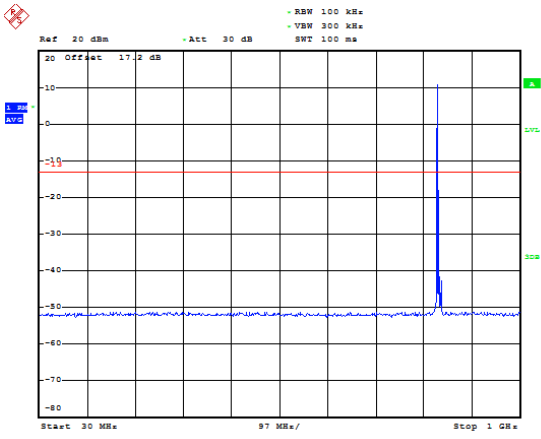

Date: 9.SEP.2019 20:09:58

LTE Band 5 10MHz CH-Middle 1GHz~9GHz

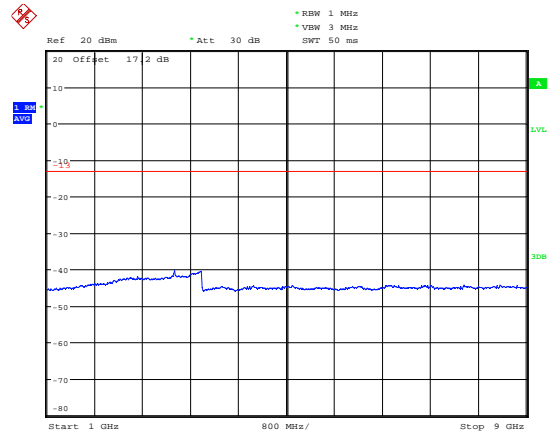

Date: 9.SEP.2019 20:04:28

LTE Band 5 10MHz CH-High 30MHz~1GHz

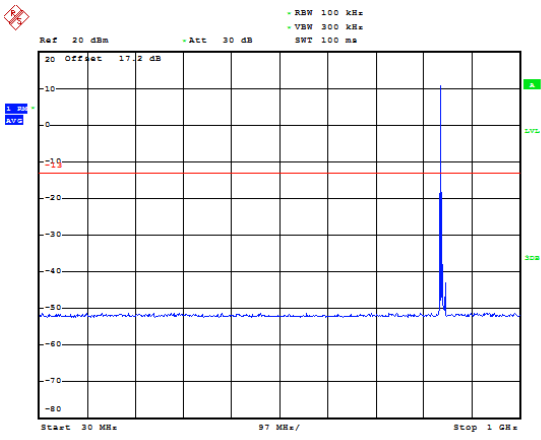

Date: 9.SEP.2019 20:10:10

LTE Band 5 10MHz CH-High 1GHz~9GHz

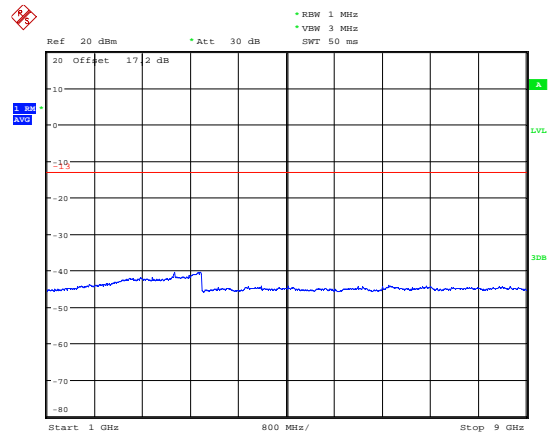

Date: 9.SEP.2019 20:04:41



LTE Band 26 1.4MHz CH-Low 30MHz~1.5GHz

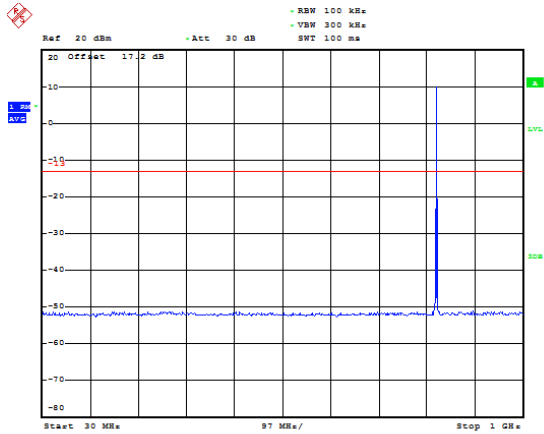

Date: 9.SEP.2019 20:48:37

LTE Band 26 1.4MHz CH-Low 1.5GHz~9GHz

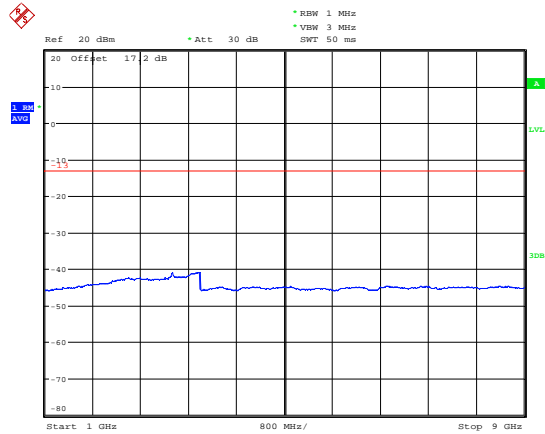

Date: 12.SEP.2019 11:23:18

LTE Band 26 1.4MHz CH-Middle 30MHz~1.5GHz

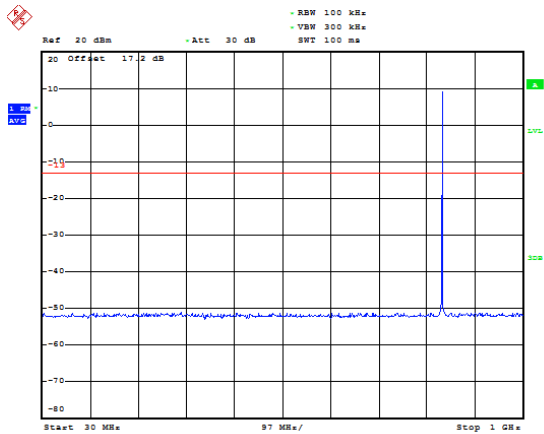

Date: 9.SEP.2019 20:48:50

LTE Band 26 1.4MHz CH-Middle 1.5GHz~9GHz

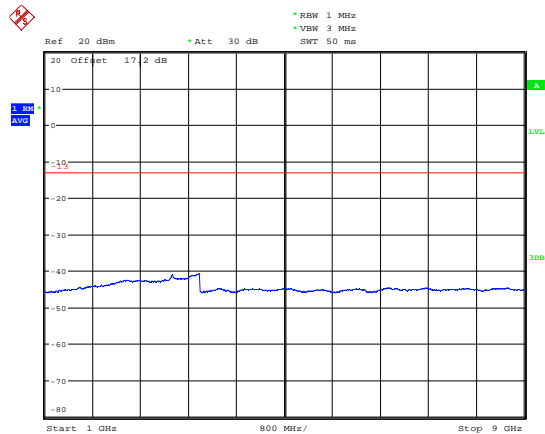

Date: 12.SEP.2019 11:23:45

LTE Band 26 1.4MHz CH-High 30MHz~1.5GHz

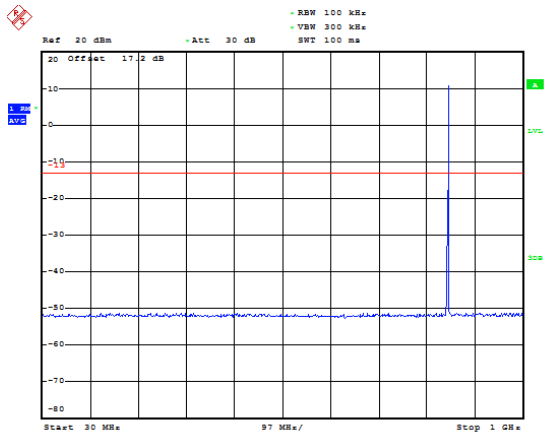

Date: 9.SEP.2019 20:49:07

LTE Band 26 1.4MHz CH-High 1.5GHz~9GHz

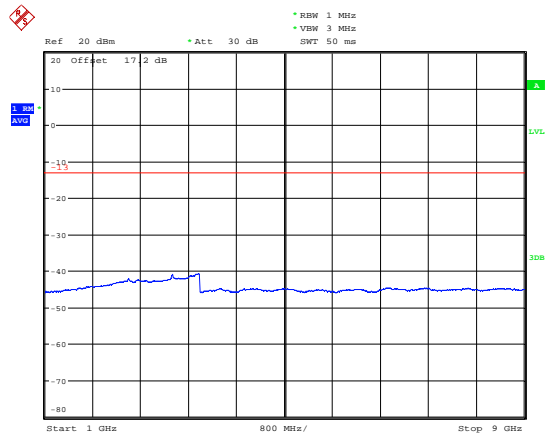

Date: 12.SEP.2019 11:24:18



LTE Band 26 3MHz CH-Low 30MHz~1.5GHz

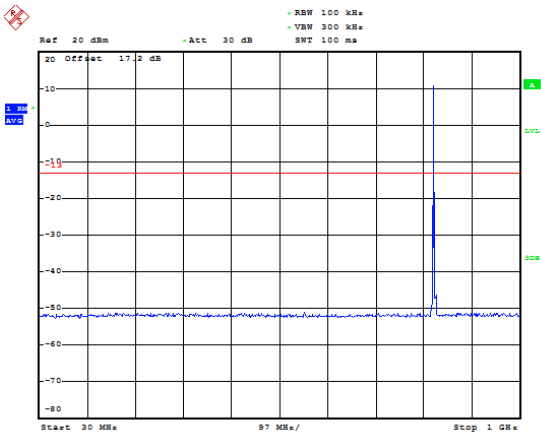

Date: 9.SEP.2019 20:49:26

LTE Band 26 3MHz CH-Low 1.5GHz~9GHz

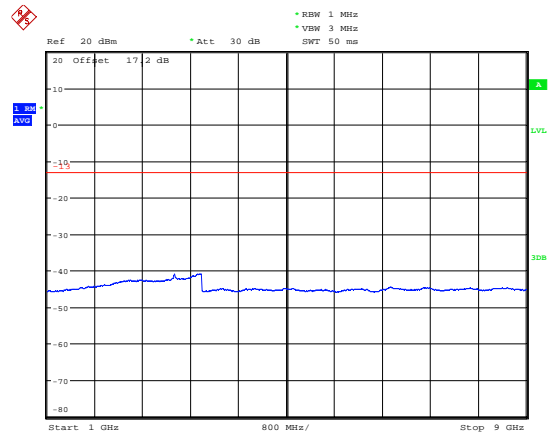

Date: 12.SEP.2019 11:29:37

LTE Band 26 3MHz CH-Middle 30MHz~1.5GHz

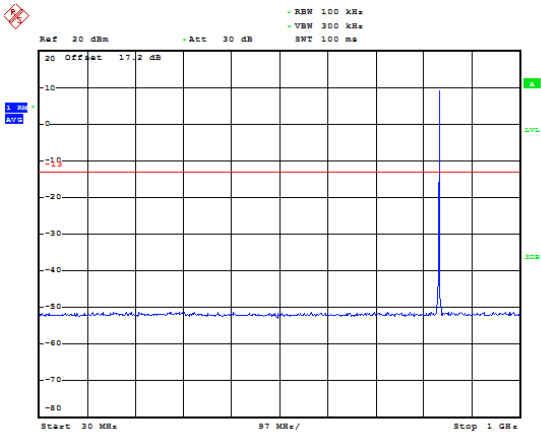

Date: 9.SEP.2019 20:50:03

LTE Band 26 3MHz CH-Middle 1.5GHz~9GHz

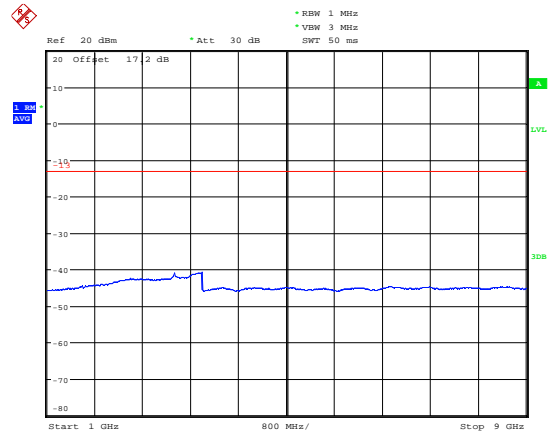

Date: 12.SEP.2019 11:29:56

LTE Band 26 3MHz CH-High 30MHz~1.5GHz

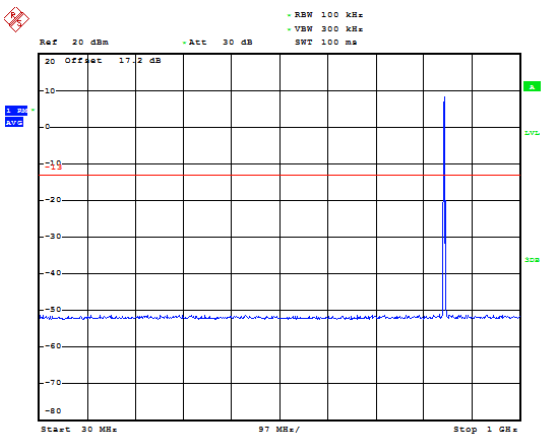

Date: 9.SEP.2019 20:50:25

LTE Band 26 3MHz CH-High 1.5GHz~9GHz

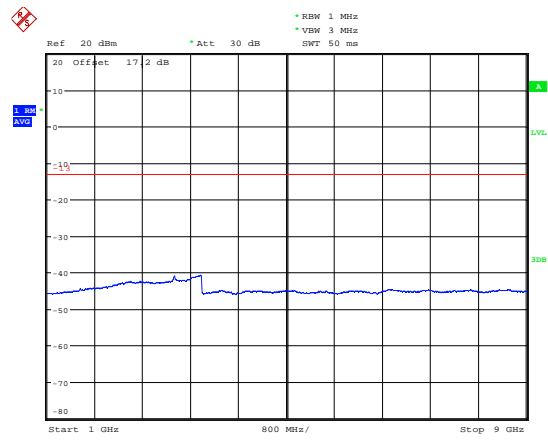

Date: 12.SEP.2019 11:30:23



LTE Band 26 5MHz CH-Low 30MHz~1.5GHz

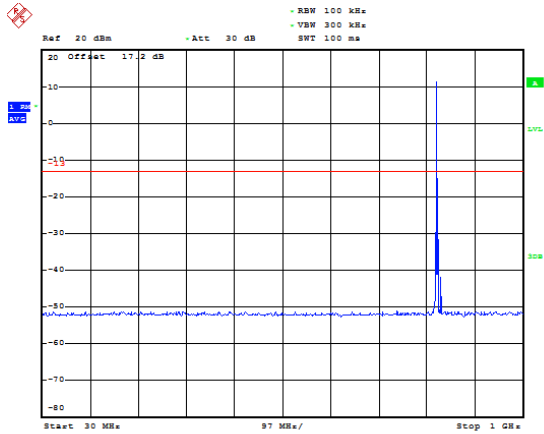

Date: 9.SEP.2019 20:50:46

LTE Band 26 5MHz CH-Low 1.5GHz~9GHz

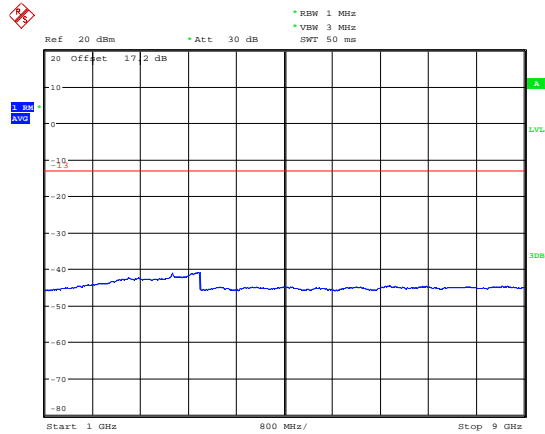

Date: 12.SEP.2019 11:30:41

LTE Band 26 5MHz CH-Middle 30MHz~1.5GHz

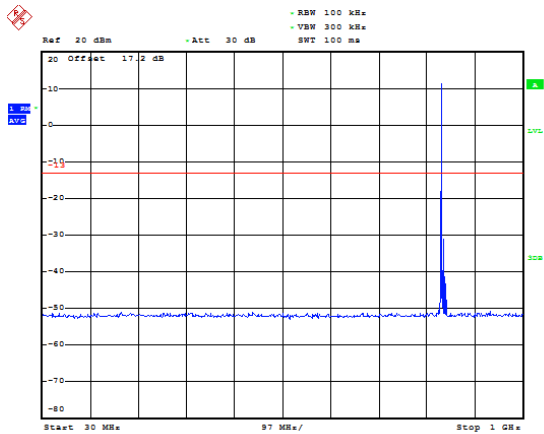

Date: 9.SEP.2019 20:51:01

LTE Band 26 5MHz CH-Middle 1.5GHz~9GHz

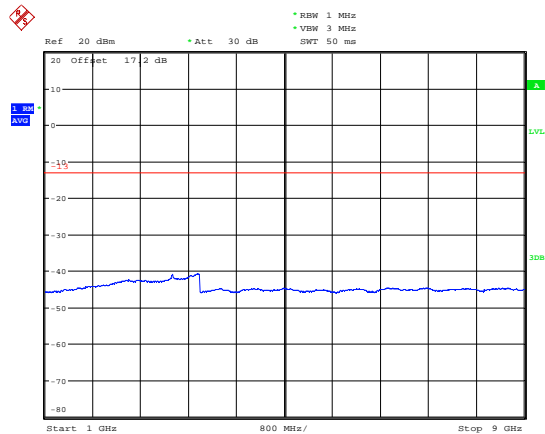

Date: 12.SEP.2019 11:30:56

LTE Band 26 5MHz CH-High 30MHz~1.5GHz

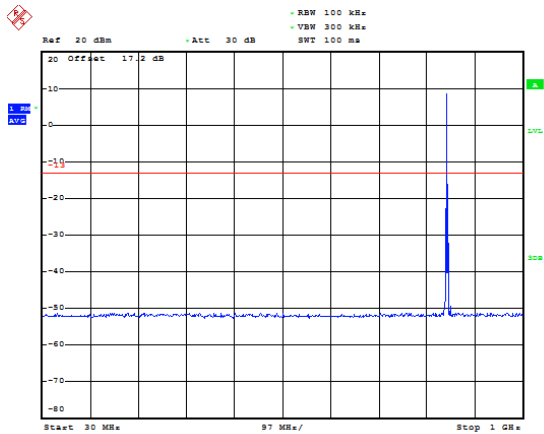

Date: 9.SEP.2019 20:51:16

LTE Band 26 5MHz CH-High 1.5GHz~9GHz

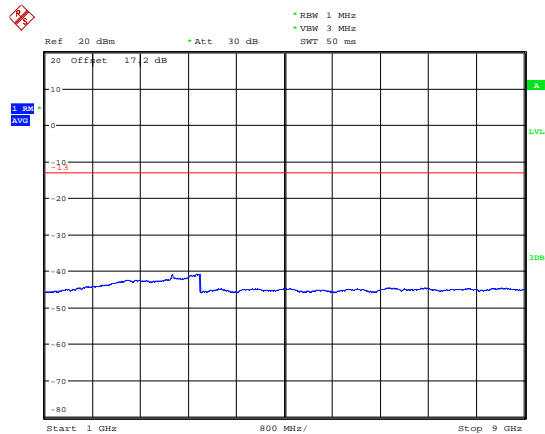

Date: 12.SEP.2019 11:31:14



LTE Band 26 10MHz CH-Low 30MHz~1.5GHz

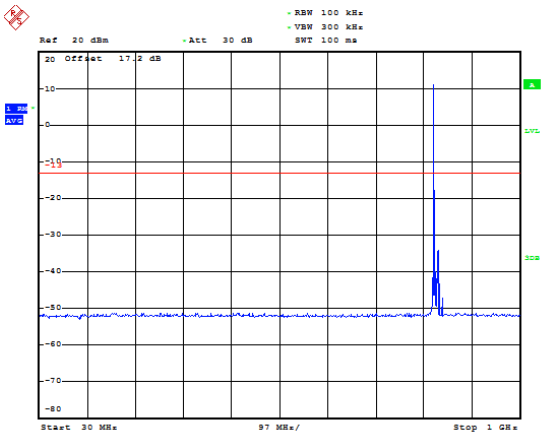

Date: 9.SEP.2019 20:51:44

LTE Band 26 10MHz CH-Low 1.5GHz~9GHz

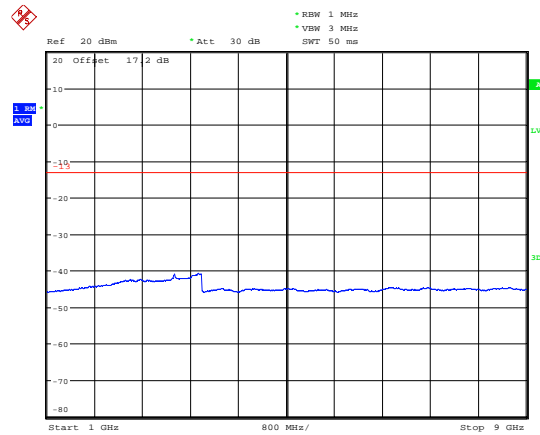

Date: 12.SEP.2019 11:31:31

LTE Band 26 10MHz CH-Middle 30MHz~1.5GHz

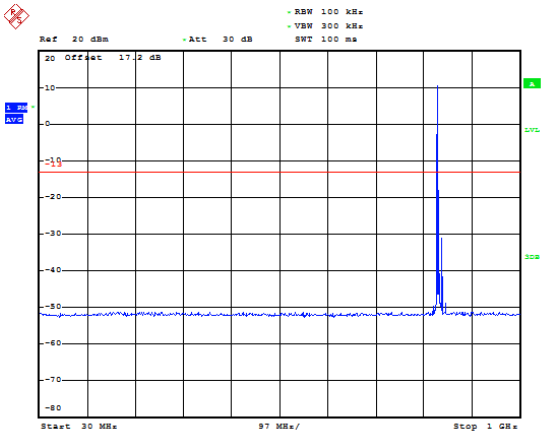

Date: 9.SEP.2019 20:51:59

LTE Band 26 10MHz CH-Middle 1.5GHz~9GHz

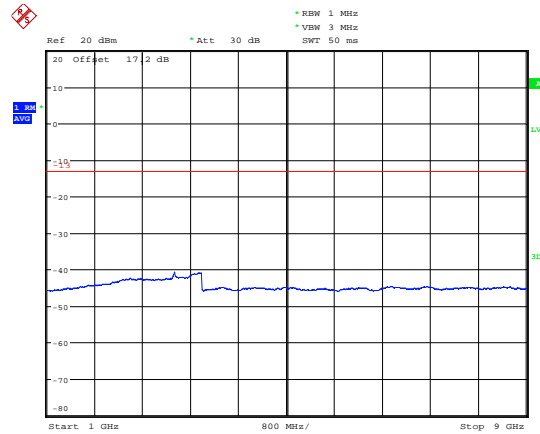

Date: 12.SEP.2019 11:31:57

LTE Band 26 10MHz CH-High 30MHz~1.5GHz

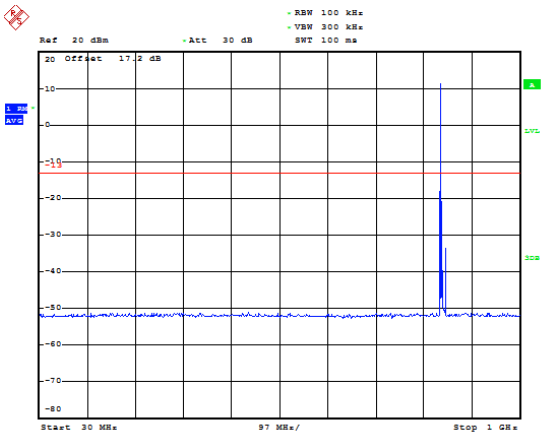

Date: 9.SEP.2019 20:52:19

LTE Band 26 10MHz CH-High 1.5GHz~9GHz

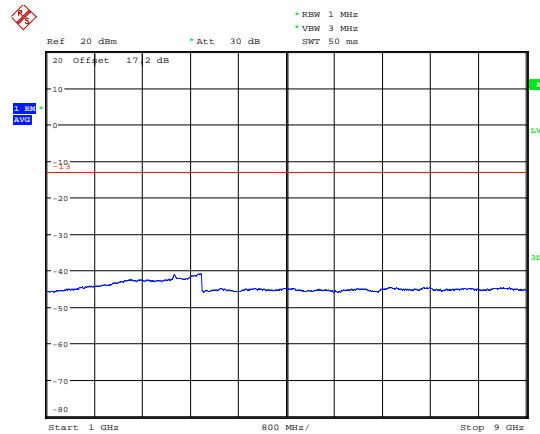

Date: 12.SEP.2019 11:32:21



LTE Band 26 15MHz CH-Low 30MHz~1.5GHz

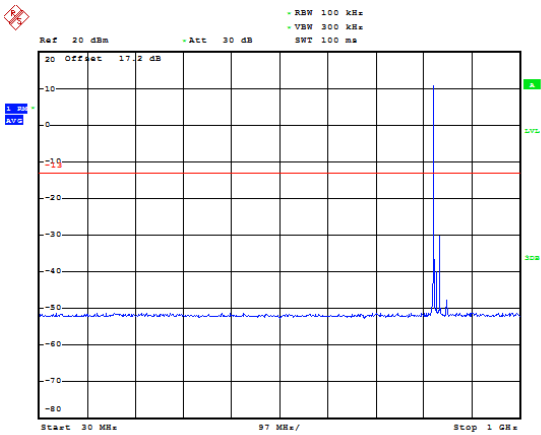

Date: 9.SEP.2019 20:52:49

LTE Band 26 15MHz CH-Low 1.5GHz~9GHz

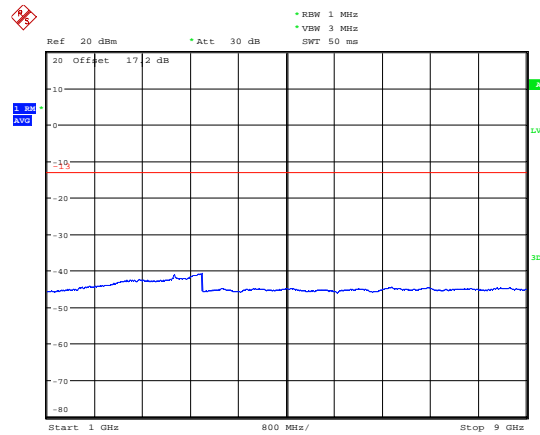

Date: 12.SEP.2019 11:32:43

LTE Band 26 15MHz CH-Middle 30MHz~1.5GHz

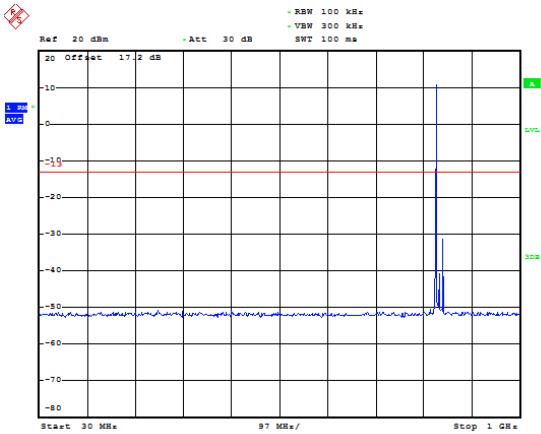

Date: 9.SEP.2019 20:56:18

LTE Band 26 15MHz CH-Middle 1.5GHz~9GHz

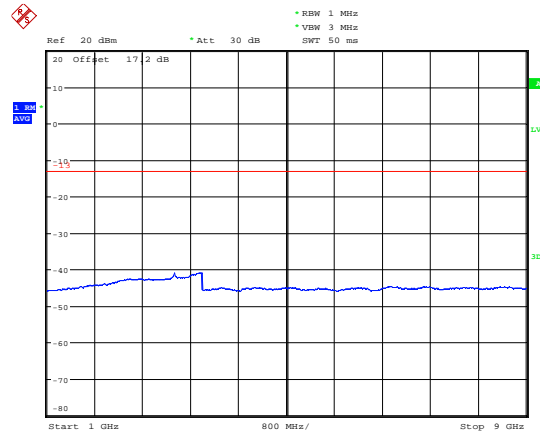

Date: 12.SEP.2019 11:33:06

LTE Band 26 15MHz CH-High 30MHz~1.5GHz

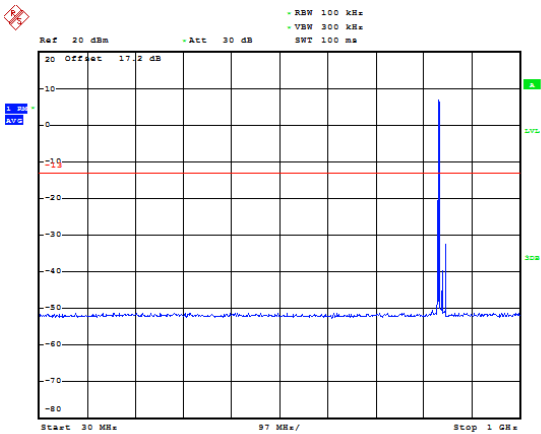

Date: 9.SEP.2019 20:56:47

LTE Band 26 15MHz CH-High 1.5GHz~9GHz

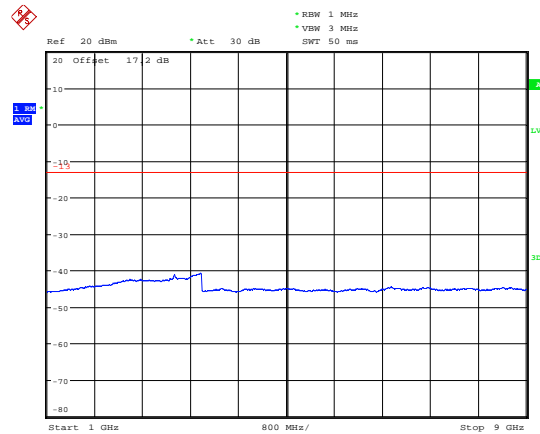

Date: 12.SEP.2019 11:33:26

6.7. Radiates Spurious Emission

Sweep the whole frequency band through the range from 9kHz to the 10th harmonic of the carrier, the emissions below the noise floor will not be recorded in the report.

GSM 850 CH-Middle

Harmonic	Frequency (MHz)	SG (dBm)	Cable Loss (dB)	Gain (dBi)	Antenna Polarization	ERP Level (dBm)	Limit (dBm)	Margin (dB)	Azimuth (deg)
2	1673	-61.10	2.00	10.75	Horizontal	-54.50	-13.00	41.50	135
3	2498	-56.58	2.51	11.05	Horizontal	-50.19	-13.00	37.19	90
4	3346	-53.80	4.20	11.15	Horizontal	-49.00	-13.00	36.00	315
5	4183	-53.50	5.20	11.15	Horizontal	-49.70	-13.00	36.70	225
6	5020	-55.20	5.50	11.95	Horizontal	-50.90	-13.00	37.90	180
7	5856	-52.50	5.70	13.55	Horizontal	-46.80	-13.00	33.80	135
8	6693	-52.80	6.30	13.75	Horizontal	-47.50	-13.00	34.50	45
9	7529	-59.40	6.80	13.85	Horizontal	-54.50	-13.00	41.50	135
10	8366	-55.39	6.90	14.25	Horizontal	-50.19	-13.00	37.19	90

Note: 1.The other Spurious RF Radiated emissions level is no more than noise floor.
 2.The worst emission was found in the antenna is Horizontal position.

WCDMA Band V CH-Middle

Harmonic	Frequency (MHz)	SG (dBm)	Cable Loss (dB)	Gain (dBi)	Antenna Polarization	ERP Level (dBm)	Limit (dBm)	Margin (dB)	Azimuth (deg)
2	1673	-65.70	2.00	10.75	Horizontal	-59.10	-13.00	46.10	180
3	2510	-64.99	2.51	11.05	Horizontal	-58.60	-13.00	45.60	90
4	3346	-63.30	4.20	11.15	Horizontal	-58.50	-13.00	45.50	45
5	4183	-59.30	5.20	11.15	Horizontal	-55.50	-13.00	42.50	315
6	5020	-58.00	5.50	11.95	Horizontal	-53.70	-13.00	40.70	0
7	5856	-60.00	5.70	13.55	Horizontal	-54.30	-13.00	41.30	45
8	6693	-58.10	6.30	13.75	Horizontal	-52.80	-13.00	39.80	135
9	8366	-55.00	6.80	13.85	Horizontal	-50.10	-13.00	37.10	90
10	3346	-55.30	6.90	14.25	Horizontal	-50.10	-13.00	37.10	180

Note: 1.The other Spurious RF Radiated emissions level is no more than noise floor.
 2.The worst emission was found in the antenna is Horizontal position.



LTE Band 5 1.4MHz CH-Middle

Harmonic	Frequency (MHz)	SG (dBm)	Cable Loss (dB)	Gain (dBi)	Antenna Polarization	ERP Level (dBm)	Limit (dBm)	Margin (dB)	Azimuth (deg)
2	1673.0	-64.74	2.00	10.75	Horizontal	-58.14	-13.00	45.14	315
3	2509.5	-61.18	2.51	11.05	Horizontal	-54.79	-13.00	41.79	90
4	3346.0	-63.46	4.20	11.15	Horizontal	-58.66	-13.00	45.66	45
5	4182.5	-62.23	5.20	11.15	Horizontal	-58.43	-13.00	45.43	225
6	5019.0	-60.64	5.50	11.95	Horizontal	-56.34	-13.00	43.34	0
7	5855.5	-61.96	5.70	13.55	Horizontal	-56.26	-13.00	43.26	270
8	6692.0	-60.24	6.30	13.75	Horizontal	-54.94	-13.00	41.94	315
9	7528.5	-56.40	6.80	13.85	Horizontal	-51.50	-13.00	38.50	45
10	8365.0	-57.10	6.90	14.25	Horizontal	-51.90	-13.00	38.90	135

Note: 1.The other Spurious RF Radiated emissions level is no more than noise floor.

2.The worst emission was found in the antenna is Horizontal position.



LTE Band 5 5MHz CH-Middle

Harmonic	Frequency (MHz)	SG (dBm)	Cable Loss (dB)	Gain (dBi)	Antenna Polarization	ERP Level (dBm)	Limit (dBm)	Margin (dB)	Azimuth (deg)
2	1673.0	-66.03	2.00	10.75	Horizontal	-59.43	-13.00	46.43	135
3	2509.5	-60.29	2.51	11.05	Horizontal	-53.90	-13.00	40.90	45
4	3346.0	-63.47	4.20	11.15	Horizontal	-58.67	-13.00	45.67	225
5	4182.5	-57.56	5.20	11.15	Horizontal	-53.76	-13.00	40.76	135
6	5019.0	-59.86	5.50	11.95	Horizontal	-55.56	-13.00	42.56	45
7	5855.5	-61.72	5.70	13.55	Horizontal	-56.02	-13.00	43.02	270
8	6692.0	-58.86	6.30	13.75	Horizontal	-53.56	-13.00	40.56	0
9	7528.5	-56.40	6.80	13.85	Horizontal	-51.50	-13.00	38.50	90
10	8365.0	-56.88	6.90	14.25	Horizontal	-51.68	-13.00	38.68	45

Note: 1.The other Spurious RF Radiated emissions level is no more than noise floor.
2.The worst emission was found in the antenna is Horizontal position.

LTE Band 5 10MHz CH-Middle

Harmonic	Frequency (MHz)	SG (dBm)	Cable Loss (dB)	Gain (dBi)	Antenna Polarization	ERP Level (dBm)	Limit (dBm)	Margin (dB)	Azimuth (deg)
2	1673.0	-66.59	2.00	10.75	Horizontal	-59.99	-13.00	46.99	0
3	2509.5	-60.92	2.51	11.05	Horizontal	-54.53	-13.00	41.53	90
4	3346.0	-64.29	4.20	11.15	Horizontal	-59.49	-13.00	46.49	225
5	4182.5	-61.97	5.20	11.15	Horizontal	-58.17	-13.00	45.17	90
6	5019.0	-57.02	5.50	11.95	Horizontal	-52.72	-13.00	39.72	315
7	5855.5	-62.28	5.70	13.55	Horizontal	-56.58	-13.00	43.58	125
8	6692.0	-59.44	6.30	13.75	Horizontal	-54.14	-13.00	41.14	90
9	7528.5	-56.40	6.80	13.85	Horizontal	-51.50	-13.00	38.50	180
10	8365.0	-56.26	6.90	14.25	Horizontal	-51.06	-13.00	38.06	45

Note: 1.The other Spurious RF Radiated emissions level is no more than noise floor.
2.The worst emission was found in the antenna is Horizontal position.

LTE Band 26 1.4MHz CH-Middle

Harmonic	Frequency (MHz)	SG (dBm)	Cable Loss (dB)	Gain (dBi)	Antenna Polarization	ERP Level (dBm)	Limit (dBm)	Margin (dB)	Azimuth (deg)
2	1663.00	-66.08	2.00	10.75	Horizontal	-59.48	-13.00	46.48	225
3	2494.50	-60.97	2.51	11.05	Horizontal	-54.58	-13.00	41.58	90
4	3326.00	-63.61	4.20	11.15	Horizontal	-58.81	-13.00	45.81	180
5	4157.50	-62.78	5.20	11.15	Horizontal	-58.98	-13.00	45.98	45
6	4989.00	-60.44	5.50	11.95	Horizontal	-56.14	-13.00	43.14	225
7	5820.50	-61.42	5.70	13.55	Horizontal	-55.72	-13.00	42.72	90
8	6652.00	-59.27	6.30	13.75	Horizontal	-53.97	-13.00	40.97	315
9	7483.50	-57.59	6.80	13.85	Horizontal	-52.69	-13.00	39.69	90
10	8315.00	-55.31	6.90	14.25	Horizontal	-50.11	-13.00	37.11	225

Note: 1.The other Spurious RF Radiated emissions level is no more than noise floor.
 2.The worst emission was found in the antenna is Horizontal position.

LTE Band 26 5MHz CH-Middle

Harmonic	Frequency (MHz)	SG (dBm)	Cable Loss (dB)	Gain (dBi)	Antenna Polarization	ERP Level (dBm)	Limit (dBm)	Margin (dB)	Azimuth (deg)
2	1663.00	-65.01	2.00	10.75	Horizontal	-58.41	-13.00	45.41	90
3	2494.50	-62.63	2.51	11.05	Horizontal	-56.24	-13.00	43.24	135
4	3326.00	-65.44	4.20	11.15	Horizontal	-60.64	-13.00	47.64	315
5	4157.50	-61.38	5.20	11.15	Horizontal	-57.58	-13.00	44.58	45
6	4989.00	-59.76	5.50	11.95	Horizontal	-55.46	-13.00	42.46	90
7	5820.50	-61.42	5.70	13.55	Horizontal	-55.72	-13.00	42.72	45
8	6652.00	-58.98	6.30	13.75	Horizontal	-53.68	-13.00	40.68	315
9	7483.50	-56.80	6.80	13.85	Horizontal	-51.90	-13.00	38.90	90
10	8315.00	-56.49	6.90	14.25	Horizontal	-51.29	-13.00	38.29	45

Note: 1.The other Spurious RF Radiated emissions level is no more than noise floor.
 2.The worst emission was found in the antenna is Horizontal position.



LTE Band 26 10MHz CH-Middle

Harmonic	Frequency (MHz)	SG (dBm)	Cable Loss (dB)	Gain (dBi)	Antenna Polarization	ERP Level (dBm)	Limit (dBm)	Margin (dB)	Azimuth (deg)
2	1663.00	-64.59	2.00	10.75	Horizontal	-57.99	-13.00	44.99	135
3	2494.50	-63.66	2.51	11.05	Horizontal	-57.27	-13.00	44.27	225
4	3326.00	-63.38	4.20	11.15	Horizontal	-58.58	-13.00	45.58	225
5	4157.50	-61.40	5.20	11.15	Horizontal	-57.60	-13.00	44.60	135
6	4989.00	-60.54	5.50	11.95	Horizontal	-56.24	-13.00	43.24	45
7	5820.50	-62.01	5.70	13.55	Horizontal	-56.31	-13.00	43.31	90
8	6652.00	-58.60	6.30	13.75	Horizontal	-53.30	-13.00	40.30	225
9	7483.50	-56.31	6.80	13.85	Horizontal	-51.41	-13.00	38.41	180
10	8315.00	-56.82	6.90	14.25	Horizontal	-51.62	-13.00	38.62	90

Note: 1.The other Spurious RF Radiated emissions level is no more than noise floor.

2.The worst emission was found in the antenna is Horizontal position.



7. Main Test Instruments

Name	Manufacturer	Type	Serial Number	Calibration Date	Expiration Date
Base Station Simulator	R&S	CMW500	113824	2019-05-19	2020-05-18
Power Splitter	Hua Xiang	SHX-GF2-2-13	10120101	/	/
Spectrum Analyzer	Key sight	N9010A	MY50210259	2019-05-19	2020-05-18
Universal Radio Communication Tester	Key sight	E5515C	MY48367192	2019-05-19	2020-05-18
Signal Analyzer	R&S	FSV30	100815	2018-12-16	2019-12-15
Loop Antenna	SCHWARZBECK	FMZB1519	1519-047	2017-09-26	2019-09-25
Trilog Antenna	SCHWARZBECK	VUBL 9163	9163-201	2017-11-18	2019-11-17
Horn Antenna	R&S	HF907	100126	2018-07-07	2020-07-06
Horn Antenna	ETS-Lindgren	3160-09	00102643	2018-06-20	2020-06-19
Signal generator	R&S	SMB 100A	102594	2019-05-19	2020-05-18
Climatic Chamber	ESPEC	SU-242	93000506	2017-12-17	2020-12-16
Preamplifier	R&S	SCU18	102327	2019-05-19	2020-05-18
MOB COMMS DC SUPPLY	Keysight	66319D	MY43004105	2019-05-20	2020-05-21
RF Cable	Agilent	SMA 15cm	0001	2019-06-14	2019-09-13
Software	R&S	EMC32	9.26.0	/	/

*****END OF REPORT *****



ANNEX A: The EUT Appearance and Change declaration letter

The EUT Appearance and Change declaration letter are submitted separately.



ANNEX B: Test Setup Photos

The Test Setup Photos is submitted separately.