

RADIO TEST REPORT

FCC 47 CFR PART 15 SUBPART E

INDUSTRY CANADA RSS-247

Test Standard	FCC Part 15.407+ RSS-247 issue 2 and RSS-GEN issue 5
Brand name	ICON/iFit
Product name	Tablet
Model No.	MP7-ARGON-C
Test Result	Pass
Statements of Conformity	Determination of compliance is based on the results of the compliance measurement, not taking into account measurement instrumentation uncertainty.

The test Result was tested by Compliance Certification Services Inc. The test data, data evaluation, test procedures, and equipment configurations shown in this report were given in ANSI C63.10: 2013 and compliance standards.

The test results of this report relate only to the tested sample (EUT) identified in this report.

The test Report of full or partial shall not copy. Without written approval of Compliance Certification Services Inc.(Wugu Laboratory)

Approved by:



Kevin Tsai
Deputy Manager

Unless otherwise stated the results shown in this test report refer only to the sample(s) tested and such sample(s) are retained for 90 days only.
除非另有說明，此報告結果僅對測試之樣品負責，同時此樣品僅保留90天。本報告未經本公司書面許可，不可部份複製。

This document is issued by the Company subject to its General Conditions of Service printed overleaf, available on request or accessible at <http://www.sgs.com.tw/Terms-and-Conditions> and, for electronic format documents, subject to Terms and Conditions for Electronic Documents at <http://www.sgs.com.tw/Terms-and-Conditions>. Attention is drawn to the limitation of liability, indemnification and jurisdiction issues defined therein. Any holder of this document is advised that information contained hereon reflects the Company's findings at the time of its intervention only and within the limits of client's instruction, if any. The Company's sole responsibility is to its Client and this document does not exonerate parties to a transaction from exercising all their rights and obligations under the transaction documents. This document cannot be reproduced, except in full, without prior written approval of the Company. Any unauthorized alteration, forgery or falsification of the content or appearance of this document is unlawful and offenders may be prosecuted to the fullest extent of the law.

Revision History

Rev.	Issue Date	Revisions	Effect Page	Revised By
00	June 23, 2020	Initial Issue	ALL	Allison Chen

Table of contents

1. GENERAL INFORMATION	4
1.1 EUT INFORMATION	4
1.2 EUT CHANNEL INFORMATION	5
1.3 ANTENNA INFORMATION	6
1.4 MEASUREMENT UNCERTAINTY	6
1.5 FACILITIES AND TEST LOCATION	7
1.6 INSTRUMENT CALIBRATION.....	8
1.7 SUPPORT AND EUT ACCESSORIES EQUIPMENT.....	9
1.8 TEST METHODOLOGY AND APPLIED STANDARDS	9
2. TEST SUMMERY	10
3. DESCRIPTION OF TEST MODES	11
3.1 THE EUT CHANNEL NUMBER OF OPERATING CONDITION.....	11
3.2 THE WORST MODE OF MEASUREMENT	12
3.3 EUT DUTY CYCLE	13
4. TEST RESULT	14
4.1 AC POWER LINE CONDUCTED EMISSION	14
4.2 26DB BANDWIDTH, 6DB BANDWIDTH AND OCCUPIED BANDWIDTH(99%)	17
4.3 OUTPUT POWER MEASUREMENT.....	35
4.4 POWER SPECTRAL DENSITY	42
4.5 RADIATION BANDEDGE AND SPURIOUS EMISSION	60
4.6 FREQUENCY STABILITY.....	173
APPENDIX-A TEST PHOTO	A-1
APPENDIX 1 - PHOTOGRAPHS OF EUT	

1. GENERAL INFORMATION

1.1 EUT INFORMATION

FCC Applicant	Compal Electronics Inc No.581 & 581-1, Ruiguang Rd., Neihu District, Taipei city, 11492 Taiwan
IC Applicant	COMPAL ELECTRONICS INC. No. 581 & 581-1, Ruiguang Rd., Neihu District Taipei R.O.C. 114 Taiwan
Manufacturer	Compal Electronics Inc No.581 & 581-1, Ruiguang Rd., Neihu District, Taipei city, 11492 Taiwan
Equipment	Tablet
Model No.	MP7-ARGON-C
Model Discrepancy	N/A
Trade Name	ICON/iFit
Received Date	May 4, 2020
Date of Test	May 8 ~ 14, 2020
Power Operation	EUT Power from Host device (DC12V)
HW Version	LA-J301P
SW Version	Android 8

Report No.: T200504W06-RP4

1.2 EUT CHANNEL INFORMATION

Frequency Range	UNII-1	
	IEEE 802.11a	5180 ~ 5240 MHz
	IEEE 802.11n HT 20 MHz	5180 ~ 5240 MHz
	IEEE 802.11n HT 40 MHz	5190 ~ 5230 MHz
	UNII-2a	
	IEEE 802.11a	5260 ~ 5320 MHz
	IEEE 802.11n HT 20 MHz	5260 ~ 5320 MHz
	IEEE 802.11n HT 40 MHz	5270 ~ 5310 MHz
	UNII-2c	
	IEEE 802.11a	5500 ~ 5700 MHz
	IEEE 802.11n HT 20 MHz	5500 ~ 5700 MHz
	IEEE 802.11n HT 40 MHz	5510 ~ 5670 MHz
	UNII-3	
	IEEE 802.11a	5745 ~ 5825 MHz
	IEEE 802.11n HT 20 MHz	5745 ~ 5825 MHz
IEEE 802.11n HT 40 MHz	5755 ~ 5795 MHz	
Modulation Type	<ol style="list-style-type: none"> 1. IEEE 802.11a mode: OFDM 2. IEEE 802.11n HT 20 MHz mode: OFDM 3. IEEE 802.11n HT 40 MHz mode: OFDM 	

Remark:

Refer as ANSI C63.10: 2013 clause 5.6.1 Table 4 for test channels

Number of frequencies to be tested		
Frequency range in which device operates	Number of frequencies	Location in frequency range of operation
<input type="checkbox"/> 1 MHz or less	1	Middle
<input type="checkbox"/> 1 MHz to 10 MHz	2	1 near top and 1 near bottom
<input checked="" type="checkbox"/> More than 10 MHz	3	1 near top, 1 near middle, and 1 near bottom

1.3 ANTENNA INFORMATION

Antenna Type	<input checked="" type="checkbox"/> PIFA <input type="checkbox"/> PCB <input type="checkbox"/> Dipole <input type="checkbox"/> Coils
Antenna Gain	2.04 dBi
Antenna Connector	IPEX

1.4 MEASUREMENT UNCERTAINTY

PARAMETER	UNCERTAINTY
AC Powerline Conducted Emission	+/- 1.2575
Emission bandwidth, 20dB bandwidth	+/- 0.0014
RF output power, conducted	+/- 1.14
Power density, conducted	+/- 1.40
3M Semi Anechoic Chamber / 30M~200M	+/- 4.12
3M Semi Anechoic Chamber / 200M~1000M	+/- 4.68
3M Semi Anechoic Chamber / 1G~8G	+/- 5.18
3M Semi Anechoic Chamber / 8G~18G	+/- 5.47
3M Semi Anechoic Chamber / 18G~26G	+/- 3.81
3M Semi Anechoic Chamber / 26G~40G	+/- 3.87

Remark:

1. This uncertainty represents an expanded uncertainty expressed at approximately the 95% confidence level using a coverage factor of $k=2$
2. ISO/IEC 17025 requires that an estimate of the measurement uncertainties associated with the emissions test results be included in the report.

1.5 FACILITIES AND TEST LOCATION

All measurement facilities used to collect the measurement data are located at

No.11, Wugong 6th Rd., Wugu Dist., New Taipei City, Taiwan. (R.O.C.)

Test site	Test Engineer	Remark
AC Conduction Room	Dally Hong	-
Radiation	Jerry Chang	-
RF Conducted	Dally Hong	-

Remark: *The sites are constructed in conformance with the requirements of ANSI C63.7, ANSI C63.4 and CISPR Publication 22.*

Report No.: T200504W06-RP4

1.6 INSTRUMENT CALIBRATION

RF Conducted Test Site					
Name of Equipment	Manufacturer	Model	Serial Number	Calibration Date	Calibration Due
Coaxial Cable	Woken	WC12	CC003	06/28/2019	06/27/2020
Coaxial Cable	Woken	WC12	CC001	06/28/2019	06/27/2020
EXA Signal Analyzer	KEYSIGHT	N9010B	MY55460167	07/31/2019	07/30/2020
Power Meter	Anritsu	ML2495A	1149001	05/23/2019	05/22/2020
Power Seneor	Anritsu	MA2491A	030982	05/23/2019	05/22/2020
Software	N/A				

3M 966 Chamber Test Site					
Equipment	Manufacturer	Model	S/N	Cal Date	Cal Due
Bilog Antenna	Sunol Sciences	JB3	A030105	07/26/2019	07/25/2020
Coaxial Cable	HUBER SUHNER	SUCOFLEX 104PEA	20995	02/25/2020	02/24/2021
Coaxial Cable	EMCI	EMC105	190914+25111	09/20/2019	09/19/2020
Digital Thermo-Hygro Meter	WISEWIND	1206	D07	01/15/2020	01/14/2021
double Ridged Guide Horn Antenna	ETC	MCTD 1209	DRH13M02003	10/04/2019	10/03/2020
High Pass Filters	MICRO TRONICS	HPM13195	003	02/25/2020	02/24/2021
Horn Antenna	ETS LINDGREN	3116	00026370	12/18/2019	12/17/2020
Loop Ant	COM-POWER	AL-130	121051	03/27/2020	03/26/2021
Pre-Amplifier	EMEC	EM330	060609	02/25/2020	02/24/2021
Pre-Amplifier	HP	8449B	3008A00965	02/25/2020	02/24/2021
Pre-Amplifier	MITEQ	AMF-6F-18004000-37-8P	985646	06/18/2019	06/17/2020
PSA Series Spectrum Analyzer	Agilent	E4446A	MY46180323	05/29/2019	05/28/2020
Antenna Tower	CCS	CC-A-1F	N/A	N.C.R	N.C.R
Controller	CCS	CC-C-1F	N/A	N.C.R	N.C.R
Turn Table	CCS	CC-T-1F	N/A	N.C.R	N.C.R
Software	e3 6.11-20180413				

Conducted Emission Room # B					
Name of Equipment	Manufacturer	Model	Serial Number	Calibration Date	Calibration Due
CABLE	EMCI	CFD300-NL	CERF	06/27/2019	06/26/2020
EMI Test Receiver	R&S	ESCI	100064	07/26/2019	07/25/2020
LISN	SCHAFFNER	NNB 41	03/10013	02/13/2020	02/12/2021
Software	EZ-EMC(CCS-3A1-CE)				

Remark:

1. Each piece of equipment is scheduled for calibration once a year.
2. N.C.R. = No Calibration Required.

1.7 SUPPORT AND EUT ACCESSORIES EQUIPMENT

EUT Accessories Equipment					
No.	Equipment	Brand	Model	Series No.	FCC ID
	N/A				

Support Equipment					
No.	Equipment	Brand	Model	Series No.	FCC ID
1.	Adapter	WEIHAI POWER	HAS060123-EA	N/A	N/A

1.8 TEST METHODOLOGY AND APPLIED STANDARDS

The test methodology, setups and results comply with all requirements in accordance with ANSI C63.10:2013, FCC Part 2, FCC Part 15.407, KDB 789033 D02, KDB 905462 D02, RSS-247 Issue 2 and RSS-GEN Issue 5.

2. TEST SUMMERY

FCC Standard Sec.	IC Standard Sec.	Chapter	Test Item	Result
15.203	-	1.3	Antenna Requirement	Pass
15.207	RSS-Gen(8.8)	4.1	AC Conducted Emission	Pass
15.403(i)	-	4.2	26dB Bandwidth	Pass
15.407(e)	RSS-247(6.2.4)	4.2	6dB Bandwidth	Pass
15.403(i)	RSS-Gen (6.7)	4.2	Occupied Bandwidth (99%)	Pass
15.407(a)	RSS-247(6.2.1.1) RSS-247(6.2.2.1) RSS-247(6.2.3.1) RSS-247(6.2.4.1)	4.3	Output Power Measurement	Pass
15.407(a)	RSS-247(6.2.1.1) RSS-247(6.2.2.1) RSS-247(6.2.3.1) RSS-247(6.2.4.1)	4.4	Power Spectral Density	Pass
15.407(b)	RSS-247(6.2.1.2) RSS-247(6.2.2.2) RSS-247(6.2.3.2) RSS-247(6.2.4.2)	4.5	Radiation Band Edge	Pass
15.407(b)	RSS-247(6.2.1.2) RSS-247(6.2.2.2) RSS-247(6.2.3.2) RSS-247(6.2.4.2)	4.5	Radiation Spurious Emission	Pass
15.407(g)	RSS-Gen(6.11)	4.6	Frequency Stability	Pass
15.407(h)	-	4.7	Dynamic Frequency Selection	Pass

3. DESCRIPTION OF TEST MODES

3.1 THE EUT CHANNEL NUMBER OF OPERATING CONDITION

<p>Operation mode</p>	<p>1. IEEE 802.11a mode: 6Mbps 2. IEEE 802.11n HT 20 MHz mode: MCS0 3. IEEE 802.11n HT 40 MHz mode: MCS0</p>																															
<p>Operating Frequency</p>	<table border="1"> <thead> <tr> <th></th> <th>Mode</th> <th>Frequency Range (MHz)</th> </tr> </thead> <tbody> <tr> <td rowspan="3">U-NII-1</td> <td>IEEE 802.11a</td> <td>5180, 5220, 5240</td> </tr> <tr> <td>IEEE 802.11n HT 20 MHz</td> <td>5180, 5220, 5240</td> </tr> <tr> <td>IEEE 802.11n HT 40 MHz</td> <td>5190, 5230</td> </tr> <tr> <td rowspan="3">U-NII-2a</td> <td>IEEE 802.11a</td> <td>5260, 5280, 5320</td> </tr> <tr> <td>IEEE 802.11n HT 20 MHz</td> <td>5260, 5280, 5320</td> </tr> <tr> <td>IEEE 802.11n HT 40 MHz</td> <td>5270, 5310</td> </tr> <tr> <td rowspan="3">U-NII-2c</td> <td>IEEE 802.11a</td> <td>5500, 5580, 5700</td> </tr> <tr> <td>IEEE 802.11n HT 20 MHz</td> <td>5500, 5580, 5700</td> </tr> <tr> <td>IEEE 802.11n HT 40 MHz</td> <td>5510, 5550, 5670</td> </tr> <tr> <td rowspan="3">U-NII-3</td> <td>IEEE 802.11a</td> <td>5745, 5785, 5825</td> </tr> <tr> <td>IEEE 802.11n HT 20 MHz</td> <td>5745, 5785, 5825</td> </tr> <tr> <td>IEEE 802.11n HT 40 MHz</td> <td>5755, 5795</td> </tr> </tbody> </table>		Mode	Frequency Range (MHz)	U-NII-1	IEEE 802.11a	5180, 5220, 5240	IEEE 802.11n HT 20 MHz	5180, 5220, 5240	IEEE 802.11n HT 40 MHz	5190, 5230	U-NII-2a	IEEE 802.11a	5260, 5280, 5320	IEEE 802.11n HT 20 MHz	5260, 5280, 5320	IEEE 802.11n HT 40 MHz	5270, 5310	U-NII-2c	IEEE 802.11a	5500, 5580, 5700	IEEE 802.11n HT 20 MHz	5500, 5580, 5700	IEEE 802.11n HT 40 MHz	5510, 5550, 5670	U-NII-3	IEEE 802.11a	5745, 5785, 5825	IEEE 802.11n HT 20 MHz	5745, 5785, 5825	IEEE 802.11n HT 40 MHz	5755, 5795
	Mode	Frequency Range (MHz)																														
U-NII-1	IEEE 802.11a	5180, 5220, 5240																														
	IEEE 802.11n HT 20 MHz	5180, 5220, 5240																														
	IEEE 802.11n HT 40 MHz	5190, 5230																														
U-NII-2a	IEEE 802.11a	5260, 5280, 5320																														
	IEEE 802.11n HT 20 MHz	5260, 5280, 5320																														
	IEEE 802.11n HT 40 MHz	5270, 5310																														
U-NII-2c	IEEE 802.11a	5500, 5580, 5700																														
	IEEE 802.11n HT 20 MHz	5500, 5580, 5700																														
	IEEE 802.11n HT 40 MHz	5510, 5550, 5670																														
U-NII-3	IEEE 802.11a	5745, 5785, 5825																														
	IEEE 802.11n HT 20 MHz	5745, 5785, 5825																														
	IEEE 802.11n HT 40 MHz	5755, 5795																														

Remark:

1. EUT pre-scanned data rate of output power for each mode, the worst data rate were recorded in this report.
2. For Canada the EUT Frequency Range 5600~5650MHz will be disabled.

3.2 THE WORST MODE OF MEASUREMENT

AC Power Line Conducted Emission	
Test Condition	AC Power line conducted emission for line and neutral
Power supply Mode	Mode 1: EUT power by Host Device.
Worst Mode	<input checked="" type="checkbox"/> Mode 1 <input type="checkbox"/> Mode 2 <input type="checkbox"/> Mode 3 <input type="checkbox"/> Mode 4

Radiated Emission Measurement Below 1G	
Test Condition	Radiated Emission Below 1G
Power supply Mode	Mode 1: EUT power by Host Device.
Worst Mode	<input checked="" type="checkbox"/> Mode 1 <input type="checkbox"/> Mode 2 <input type="checkbox"/> Mode 3 <input type="checkbox"/> Mode 4

Radiated Emission Measurement Above 1G	
Test Condition	Radiated Emission Above 1G
Power supply Mode	Mode 1: EUT power by Host Device.
Worst Mode	<input checked="" type="checkbox"/> Mode 1 <input type="checkbox"/> Mode 2 <input type="checkbox"/> Mode 3 <input type="checkbox"/> Mode 4
Worst Position	<input type="checkbox"/> Placed in fixed position. <input type="checkbox"/> Placed in fixed position at X-Plane (E2-Plane) <input checked="" type="checkbox"/> Placed in fixed position at Y-Plane (E1-Plane) <input type="checkbox"/> Placed in fixed position at Z-Plane (H-Plane)

Remark:

1. The worst mode was record in this test report.
2. EUT pre-scanned in three axis ,X,Y, Z and two polarity, for radiated measurement. The worst case(Y-Plane) were recorded in this report
3. AC power line conducted emission and for below 1G radiation emission were performed the EUT transmit at the highest output power channel as worse case.

Report No.: T200504W06-RP4

3.3 EUT DUTY CYCLE

Duty Cycle				
Configuration	Duty Cycle (%)	Duty Factor (dB) =10*log (1/Duty Cycle)	1/T (kHz)	VBW setting (kHz)
802.11a	97.48%	0.11	0.72	1.00
802.11n HT20	97.53%	0.11	0.77	1.00
802.11n HT40	94.88%	0.23	1.54	2.00



Report No.: T200504W06-RP4

4. TEST RESULT

4.1 AC POWER LINE CONDUCTED EMISSION

4.1.1 Test Limit

According to §15.207(a) and RSS-GEN section 8.8,

Frequency Range (MHz)	Limits(dBµV)	
	Quasi-peak	Average
0.15 to 0.50	66 to 56*	56 to 46*
0.50 to 5	56	46
5 to 30	60	50

* Decreases with the logarithm of the frequency.

4.1.2 Test Procedure

Test method Refer as ANSI C63.10: 2013 clause 6.2,

1. The EUT was placed on a non-conducted table, which is 0.8m above horizontal ground plane and 0.4m above vertical ground plane.
2. EUT connected to the line impedance stabilization network (LISN)
3. Receiver set RBW of 9kHz and Detector Peak, and note as quasi-peak and average.
4. Maximum procedure was performed on the six highest emissions to ensure EUT compliance.
5. Recorded Line for Neutral and Line.

4.1.3 Test Setup

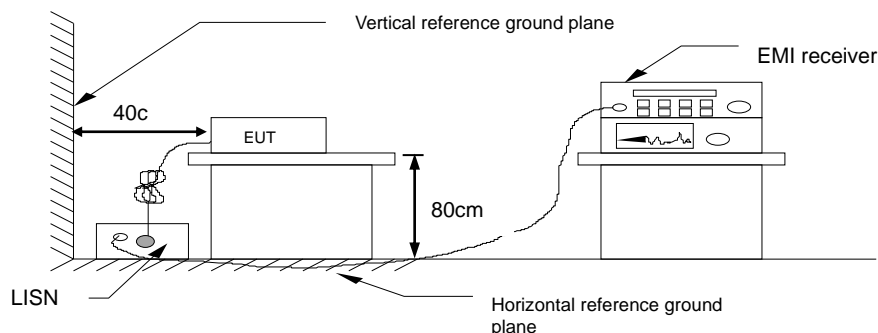

4.1.4 Test Result

Pass.

Report No.: T200504W06-RP4

Test Data

Test Mode:	Mode 1	Temp/Hum	24(°C)/ 50%RH
Phase:	Line	Test Date	May 11, 2020
		Test Engineer	Dally Hong

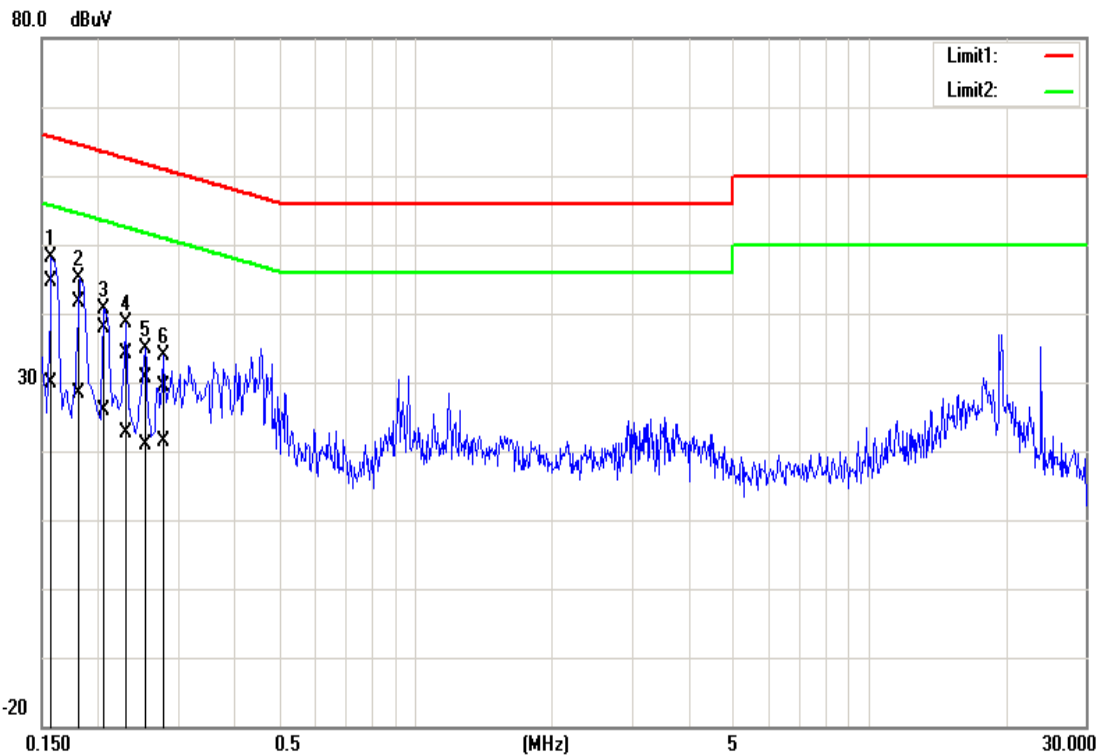

Frequency (MHz)	Quasi Peak reading (dBuV)	Average reading (dBuV)	Correction factor (dB)	Quasi Peak result (dBuV)	Average result (dBuV)	Quasi Peak limit (dBuV)	Average limit (dBuV)	Quasi Peak margin (dB)	Average margin (dB)	Remark
0.1580	34.35	19.59	10.22	44.57	29.81	65.57	55.57	-21.00	-25.76	Pass
0.1820	31.47	18.09	10.21	41.68	28.30	64.39	54.39	-22.71	-26.09	Pass
0.2060	27.61	15.71	10.21	37.82	25.92	63.37	53.37	-25.55	-27.45	Pass
0.2300	23.81	12.34	10.21	34.02	22.55	62.45	52.45	-28.43	-29.90	Pass
0.2540	20.43	10.77	10.21	30.64	20.98	61.63	51.63	-30.99	-30.65	Pass
0.2780	19.22	11.11	10.21	29.43	21.32	60.88	50.88	-31.45	-29.56	Pass

Report No.: T200504W06-RP4

Test Mode:	Mode 1	Temp/Hum	24(°C)/ 50%RH
Phase:	Neutral	Test Date	May 11, 2020
		Test Engineer	Dally Hong

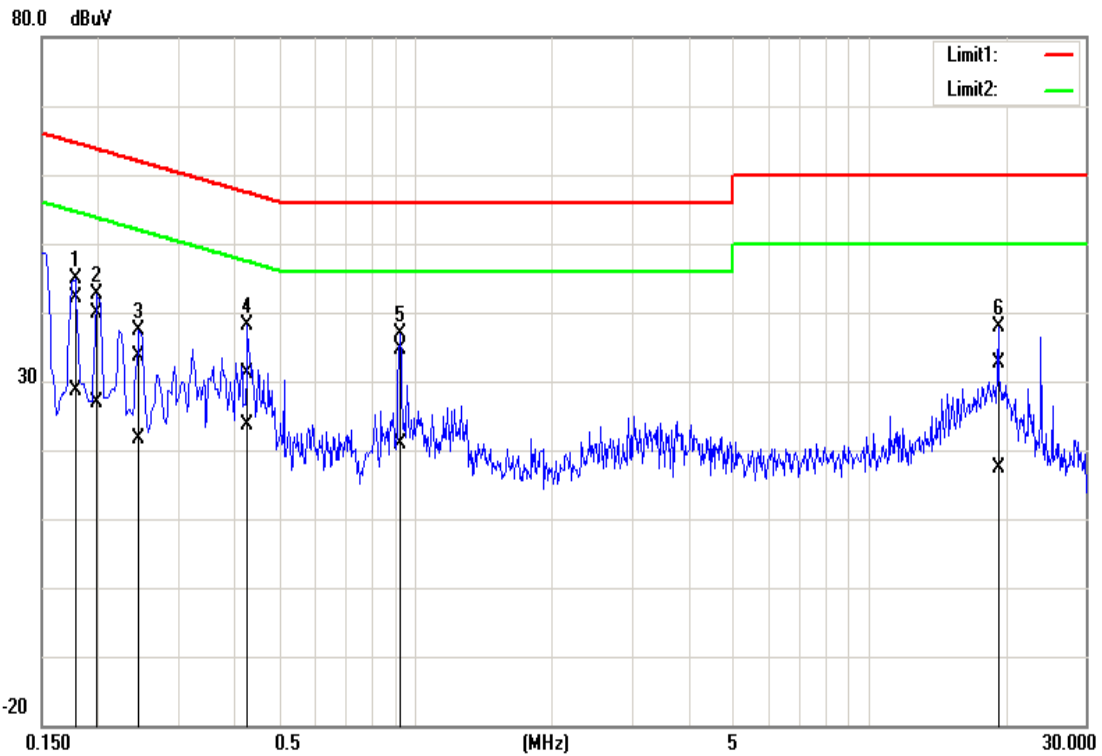

Frequency (MHz)	Quasi Peak reading (dBuV)	Average reading (dBuV)	Correction factor (dB)	Quasi Peak result (dBuV)	Average result (dBuV)	Quasi Peak limit (dBuV)	Average limit (dBuV)	Quasi Peak margin (dB)	Average margin (dB)	Remark
0.1780	31.97	18.48	10.19	42.16	28.67	64.58	54.58	-22.42	-25.91	Pass
0.1980	29.70	16.73	10.19	39.89	26.92	63.69	53.69	-23.80	-26.77	Pass
0.2460	23.50	11.52	10.19	33.69	21.71	61.89	51.89	-28.20	-30.18	Pass
0.4260	20.96	13.50	10.19	31.15	23.69	57.33	47.33	-26.18	-23.64	Pass
0.9260	24.53	10.77	10.21	34.74	20.98	56.00	46.00	-21.26	-25.02	Pass
19.2740	22.16	7.00	10.43	32.59	17.43	60.00	50.00	-27.41	-32.57	Pass

4.2 26dB BANDWIDTH, 6dB BANDWIDTH AND OCCUPIED BANDWIDTH(99%)

4.2.1 Test Limit

26 dB Bandwidth : For reporting purposes only.

6 dB Bandwidth : Least 500kHz.

Occupied Bandwidth(99%) : For reporting purposes only.

4.2.2 Test Procedure

26dB

1. This measurement setting are specified in section D of KDB 789033 D02 General UNII Test Procedures New Rules v02r01.
2. Set RBW: approximately 1% of the emission bandwidth.
3. Set the VBW>RBW.
4. Detoctor = Peak.
5. Trace mode = max hold.
6. Measure the maximum width of the emission that is 26dB down from the peak of the emission. Compare this with the RBW setting of the analyser. Readjust RBW and repeat measurement as needed until the RBW/EBW ratio is approximately 1%.

6dB

1. This measurement setting are specified in section D of KDB 789033 D02 General UNII Test Procedures New Rules v02r01.
2. Set RBW = 100 kHz.
3. Set the video bandwidth (VBW) $\geq 3 \times$ RBW.
4. Detoctor = Peak.
5. Trace mode = max hold.
6. Sweep = auto couple.
7. Allow the trace to stabilize.
8. Measure the maximum width of the emission that is constrained by the frequencies associated with the two outermost amplitude points (upper and lower frequencies) that are attenuated by 6 dB relative to the maximum level measured in the fundamental emission.

99%

1. This measurement setting are specified in section D of KDB 789033 D02 General UNII Test Procedures New Rules v02r01.
2. Set center frequency to the nominal EUT channel center frequency.
3. Set span = 1.5 times to 5.0 times the OBW.
4. Set RBW = 1 % to 5% of the OBW.
5. Set VBW $\geq 3 \times$ RBW

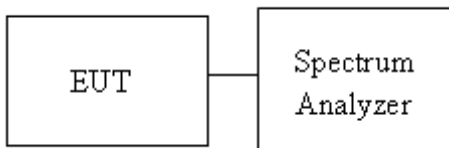
4.2.3 Test Setup

4.2.4 Test Result

UNII-1 5150-5250 MHz					
Test mode: IEEE 802.11a mode					
Channel	Frequency (MHz)	Chain 0 OBW (99%) (MHz)	Chain 1 OBW (99%) (MHz)	Chain 0 26dB BW (MHz)	Chain 1 26dB BW (MHz)
Low	5180	16.671	-	22.73	-
Mid	5220	16.658	-	21.62	-
High	5240	16.690	-	20.17	-
Test mode: IEEE 802.11n HT20 mode					
Channel	Frequency (MHz)	Chain 0 OBW (99%) (MHz)	Chain 1 OBW (99%) (MHz)	Chain 0 26dB BW (MHz)	Chain 1 26dB BW (MHz)
Low	5180	17.696	-	25.99	-
Mid	5220	17.663	-	20.92	-
High	5240	17.687	-	24.82	-
Test mode: IEEE 802.11n HT40 mode					
Channel	Frequency (MHz)	Chain 0 OBW (99%) (MHz)	Chain 1 OBW (99%) (MHz)	Chain 0 26dB BW (MHz)	Chain 1 26dB BW (MHz)
Low	5190	36.059	-	48.84	-
High	5230	36.011	-	48.71	-

UNII-2a 5250-5350 MHz					
Test mode: IEEE 802.11a mode					
Channel	Frequency (MHz)	Chain 0 OBW (99%) (MHz)	Chain 1 OBW (99%) (MHz)	Chain 0 26dB BW (MHz)	Chain 1 26dB BW (MHz)
Low	5260	16.539	-	22.48	-
Mid	5280	16.417	-	19.37	-
High	5320	16.682	-	23.53	-
Test mode: IEEE 802.11n HT20 mode					
Channel	Frequency (MHz)	Chain 0 OBW (99%) (MHz)	Chain 1 OBW (99%) (MHz)	Chain 0 26dB BW (MHz)	Chain 1 26dB BW (MHz)
Low	5260	17.635	-	24.69	-
Mid	5280	17.601	-	20.19	-
High	5320	17.677	-	23.80	-
Test mode: IEEE 802.11n HT40 mode					
Channel	Frequency (MHz)	Chain 0 OBW (99%) (MHz)	Chain 1 OBW (99%) (MHz)	Chain 0 26dB BW (MHz)	Chain 1 26dB BW (MHz)
Low	5270	36.045	-	48.52	-
High	5310	36.009	-	48.88	-

UNII-2c 5475-5725 MHz					
Test mode: IEEE 802.11a mode					
Channel	Frequency (MHz)	Chain 0 OBW (99%) (MHz)	Chain 1 OBW (99%) (MHz)	Chain 0 26dB BW (MHz)	Chain 1 26dB BW (MHz)
Low	5500	16.678	-	24.80	-
Mid	5580	16.397	-	20.12	-
High	5700	16.423	-	20.15	-
Test mode: IEEE 802.11n HT20 mode					
Channel	Frequency (MHz)	Chain 0 OBW (99%) (MHz)	Chain 1 OBW (99%) (MHz)	Chain 0 26dB BW (MHz)	Chain 1 26dB BW (MHz)
Low	5500	17.767	-	27.58	-
Mid	5580	17.768	-	27.01	-
High	5700	17.879	-	28.97	-
Test mode: IEEE 802.11n HT40 mode					
Channel	Frequency (MHz)	Chain 0 OBW (99%) (MHz)	Chain 1 OBW(99%) (MHz)	Chain 0 26dB BW (MHz)	Chain 1 26dB BW (MHz)
Low	5510	36.125	-	49.88	-
Mid	5550	36.103	-	50.00	-
High	5670	36.152	-	49.99	-

UNII-3 5725-5825MHz					
Test mode: IEEE 802.11a mode					
Channel	Frequency (MHz)	Chain 0 OBW(99%) (MHz)	Chain 1 OBW(99%) (MHz)	Chain 0 6dB BW (MHz)	Chain 1 6dB BW (MHz)
Low	5745	16.547	-	15.54	-
Mid	5785	16.472	-	15.07	-
High	5825	16.457	-	16.02	-
Test mode: IEEE 802.11n HT20 mode					
Channel	Frequency (MHz)	Chain 0 OBW(99%) (MHz)	Chain 1 OBW(99%) (MHz)	Chain 0 6dB BW (MHz)	Chain 1 6dB BW (MHz)
Low	5745	17.651	-	16.81	-
Mid	5785	17.633	-	16.73	-
High	5825	17.630	-	14.48	-
Test mode: IEEE 802.11n HT40 mode					
Channel	Frequency (MHz)	Chain 0 OBW(99%) (MHz)	Chain 1 OBW(99%) (MHz)	Chain 0 6dB BW (MHz)	Chain 1 6dB BW (MHz)
Low	5755	35.976	-	35.00	-
High	5795	35.984	-	34.74	-

Report No.: T200504W06-RP4

Test Data (99%OBW and 26dB BANDWIDTH)

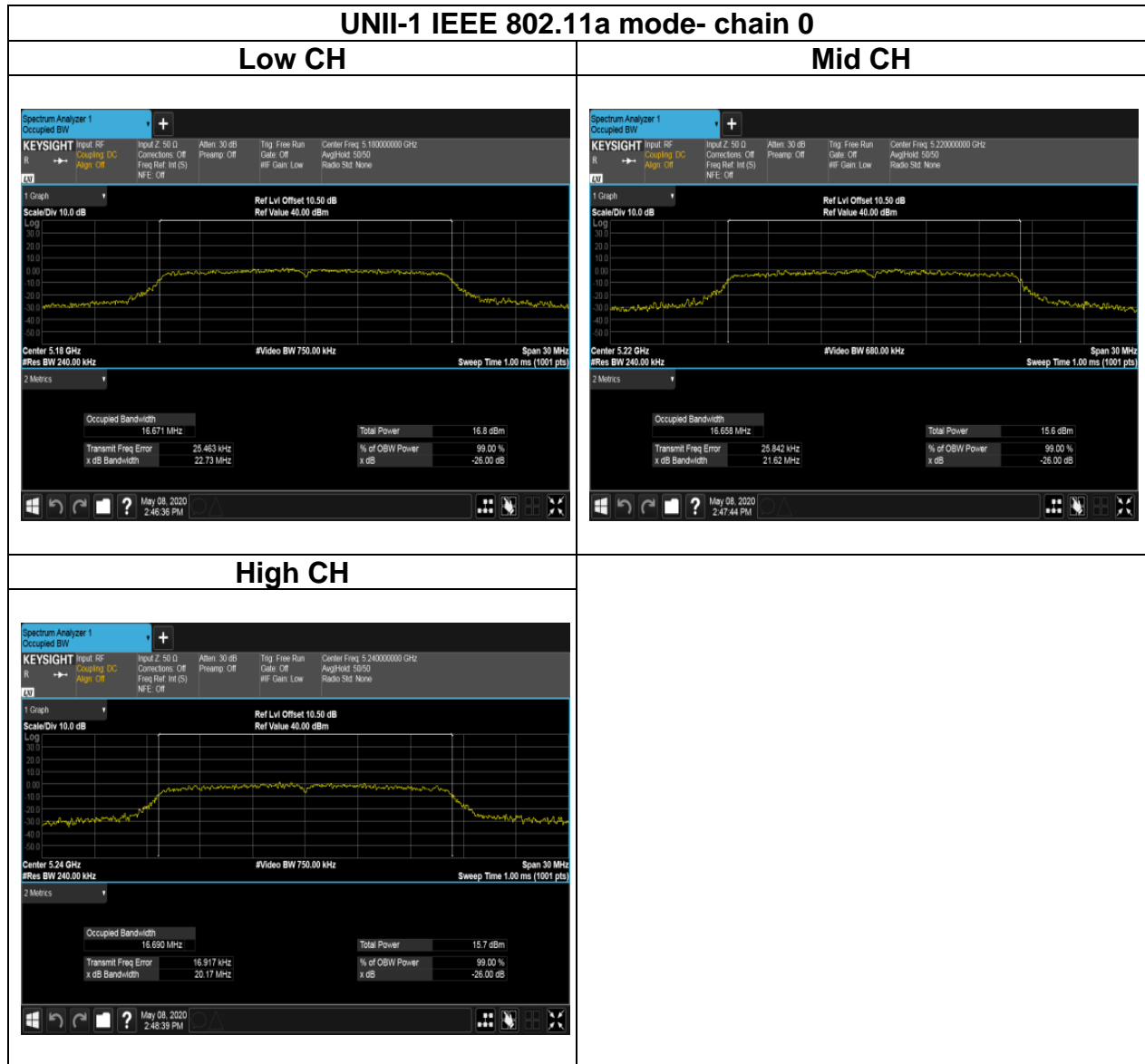

Report No.: T200504W06-RP4

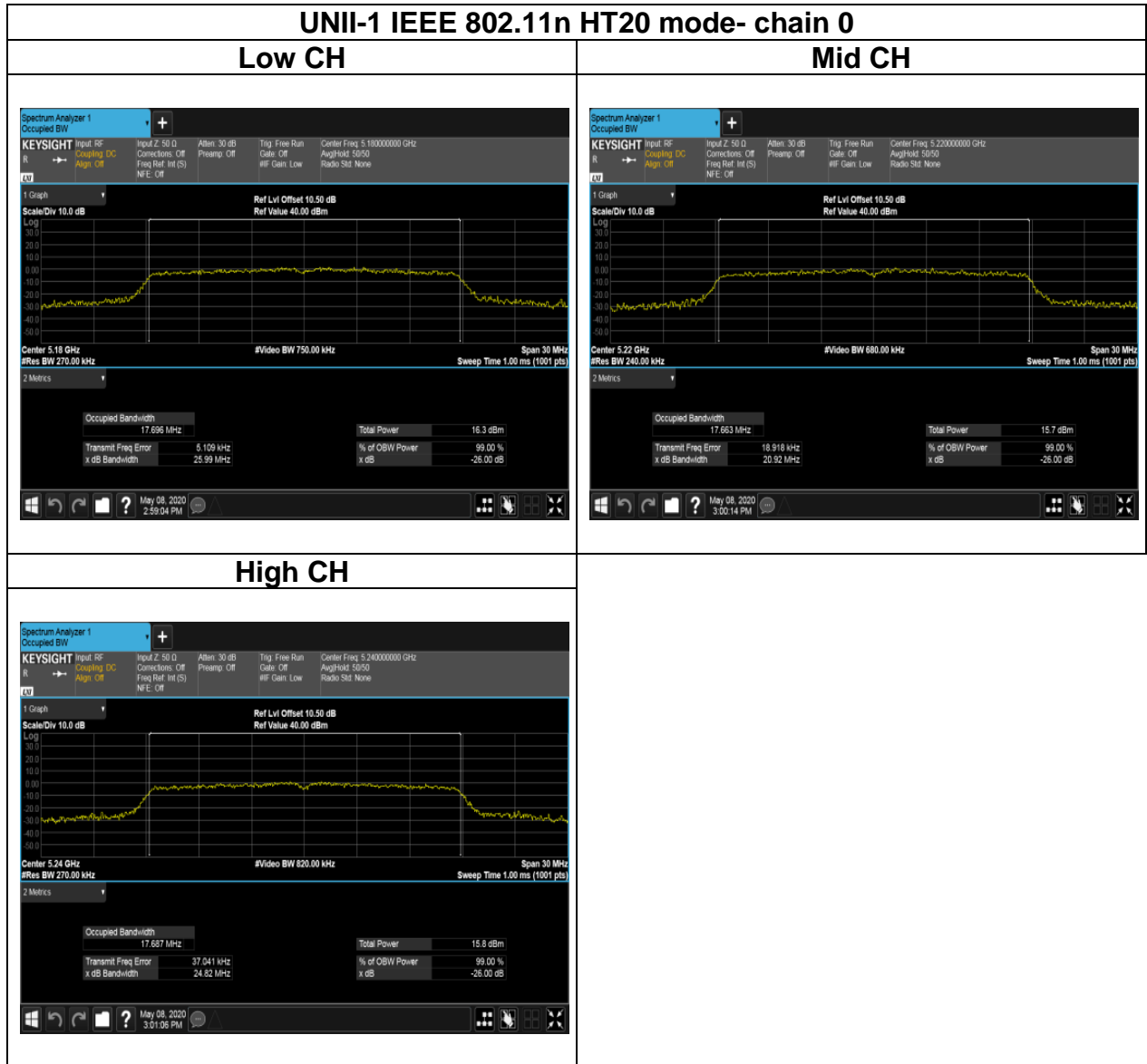

Report No.: T200504W06-RP4

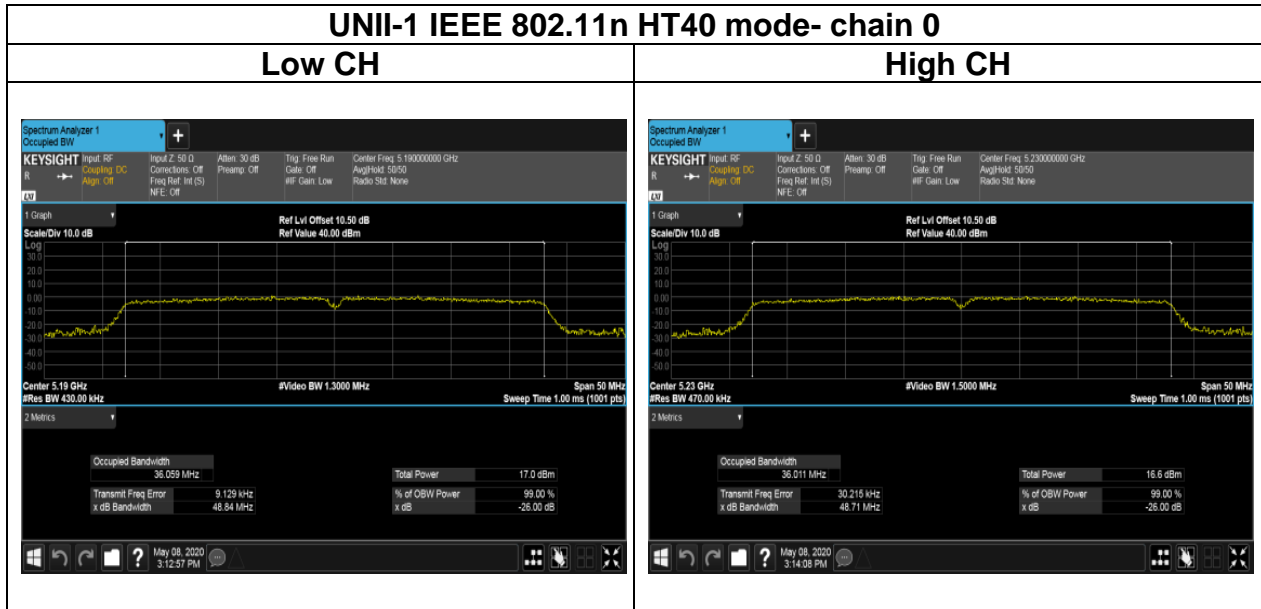

Report No.: T200504W06-RP4

Test Data (26dB BANDWIDTH)

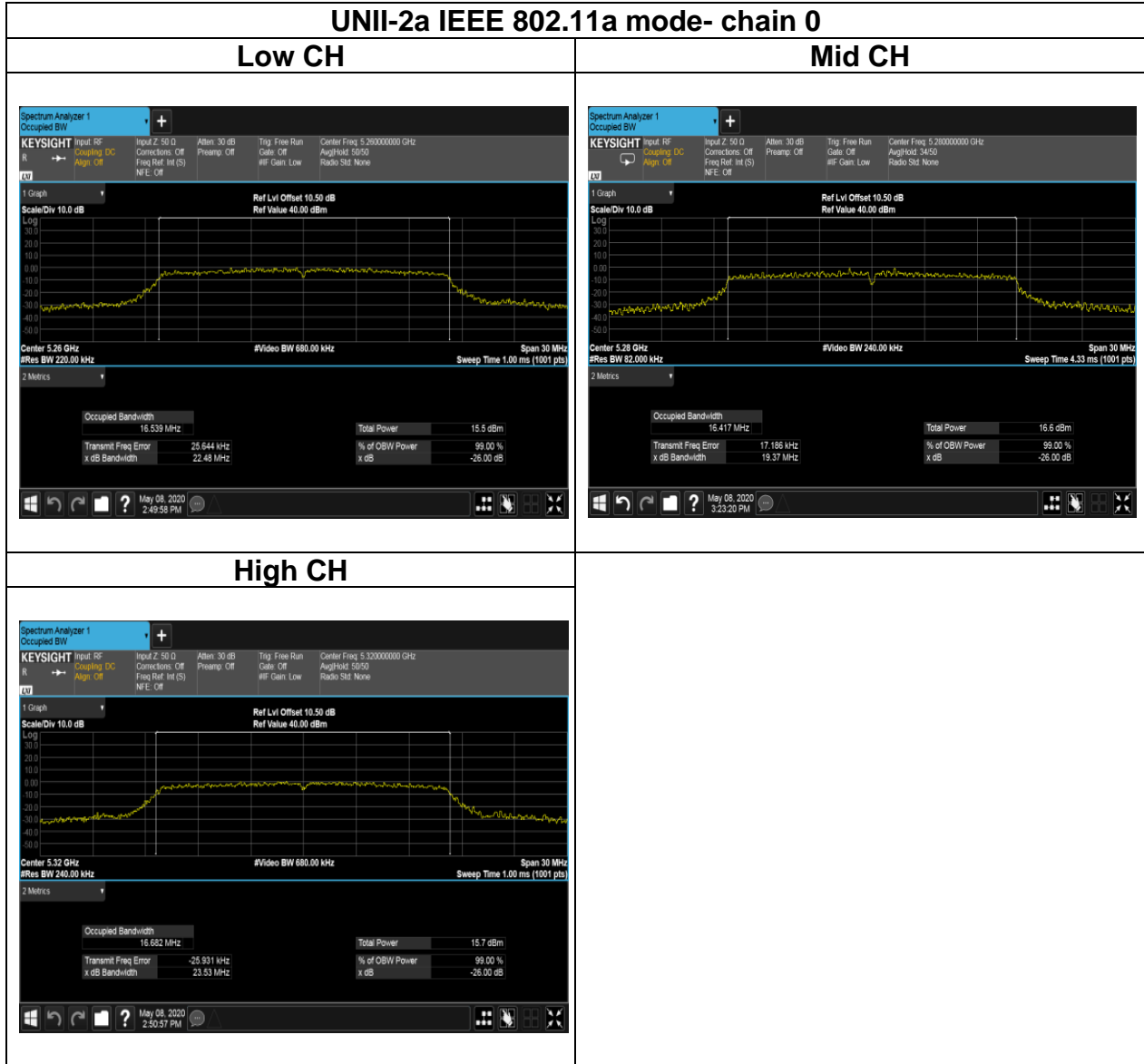

Report No.: T200504W06-RP4

UNII-2a IEEE 802.11n HT20 mode- chain 0

Low CH

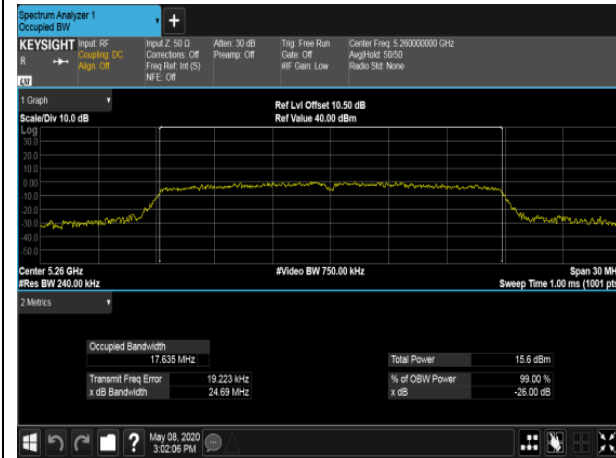

Mid CH

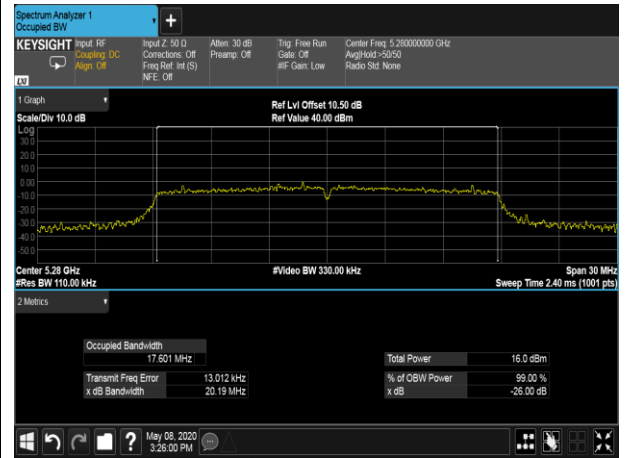

High CH



Report No.: T200504W06-RP4

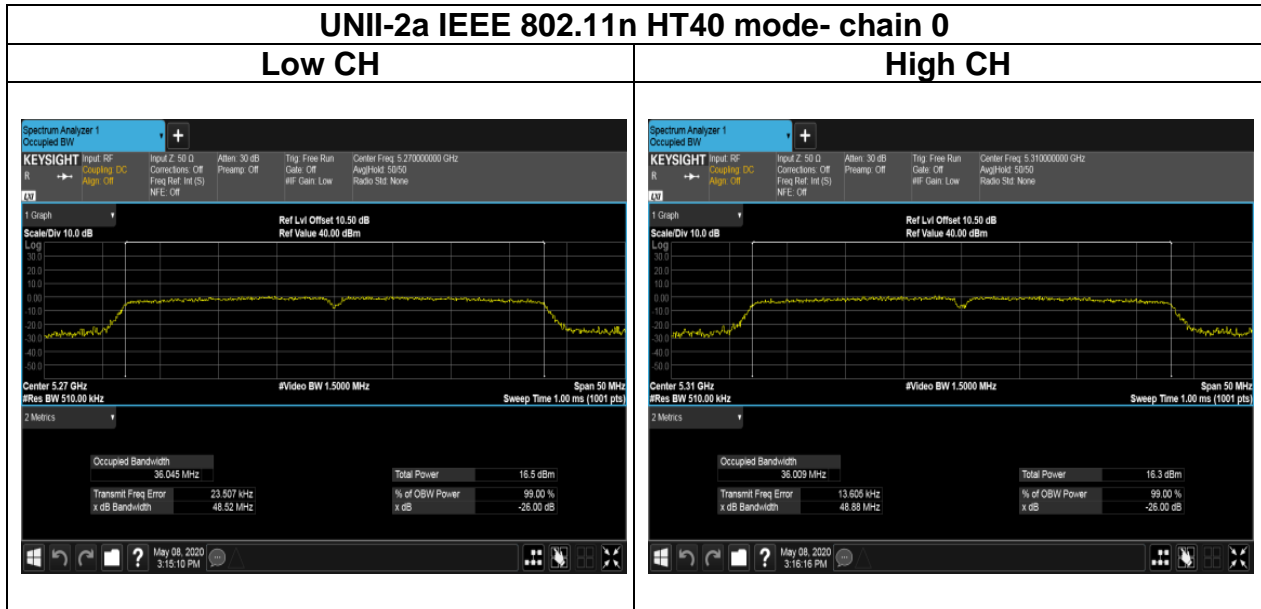

Report No.: T200504W06-RP4

Test Data (26dB BANDWIDTH)

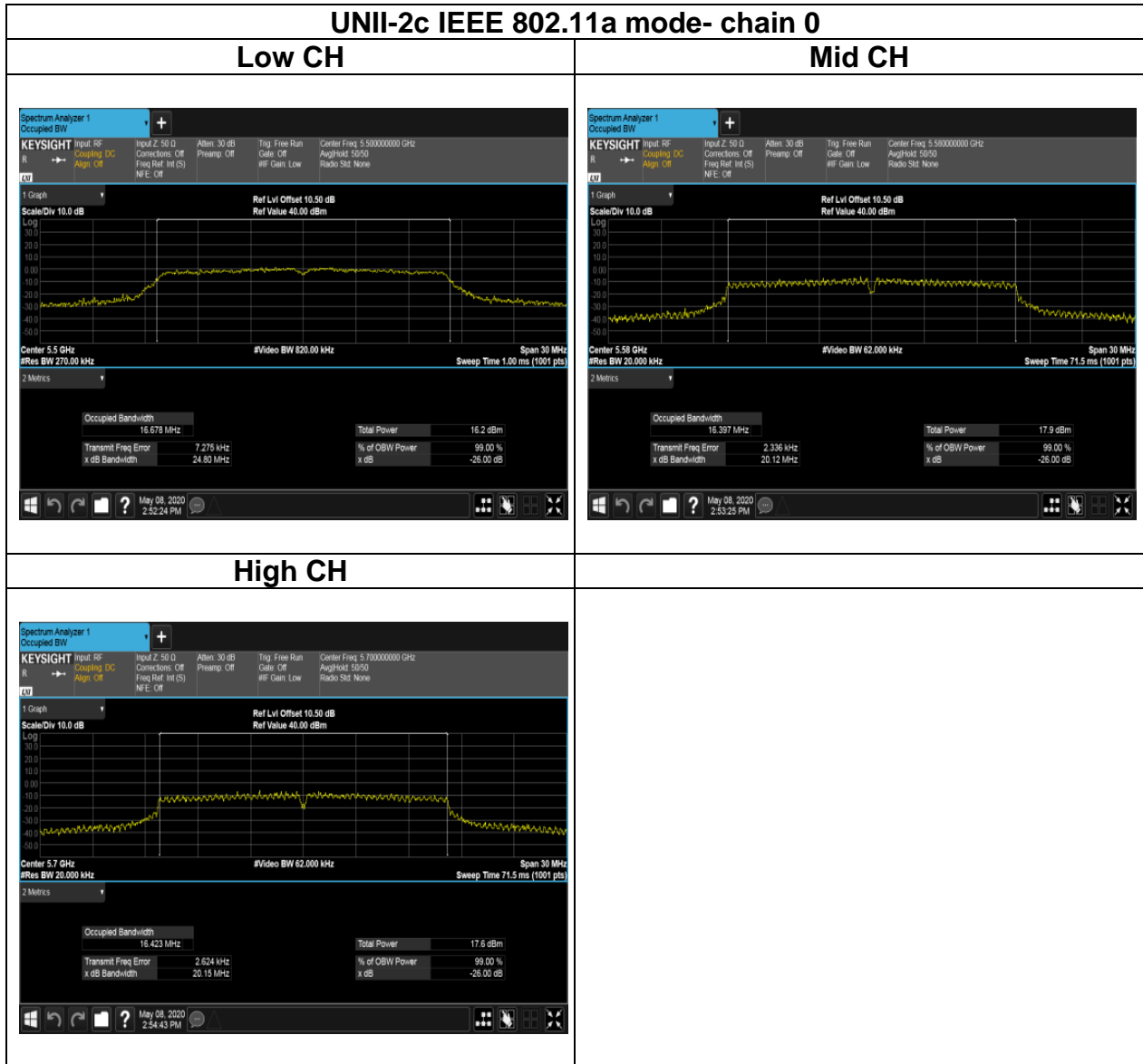

Report No.: T200504W06-RP4

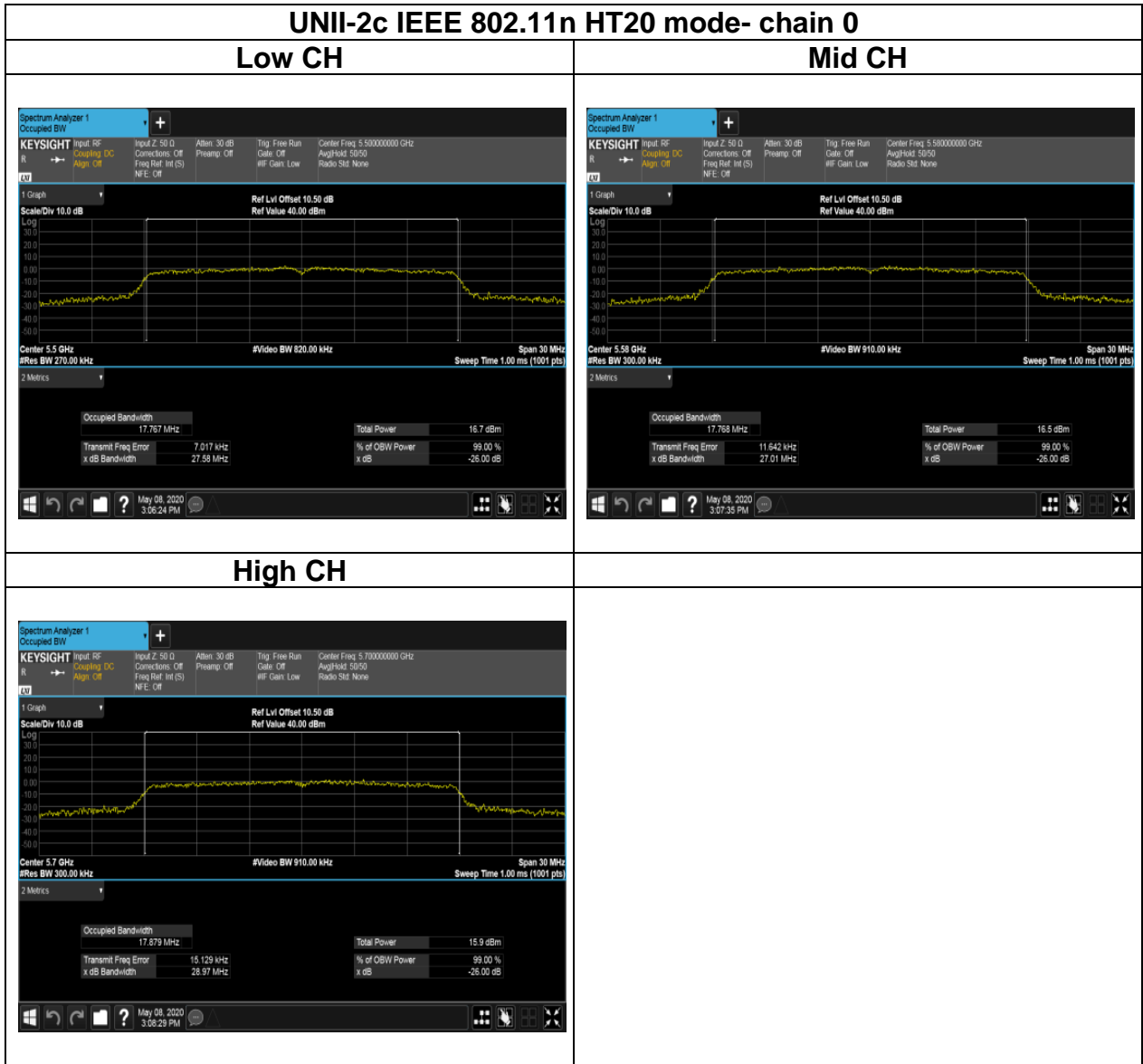

Report No.: T200504W06-RP4

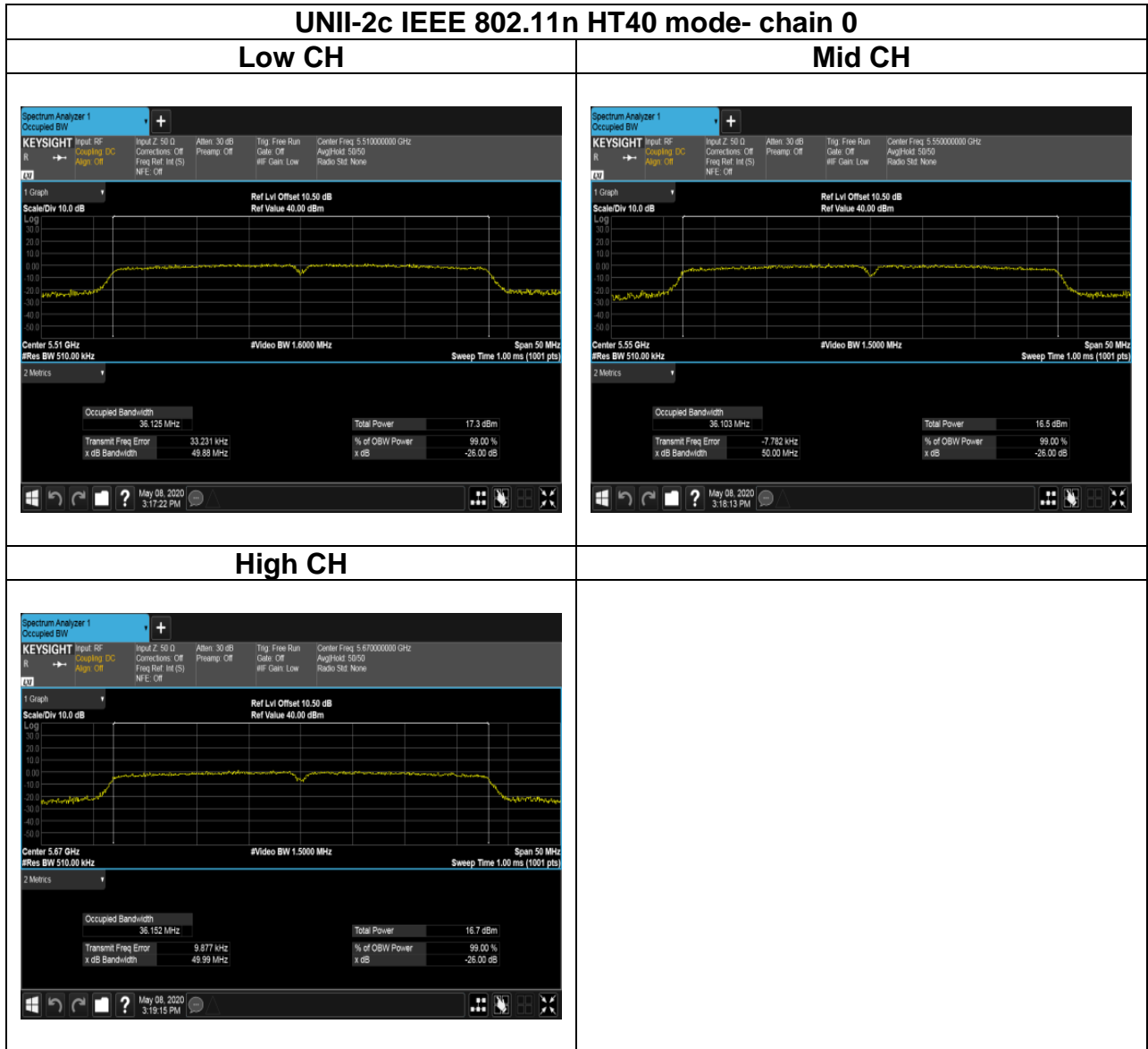

Report No.: T200504W06-RP4

Test Data (6dB BANDWIDTH)

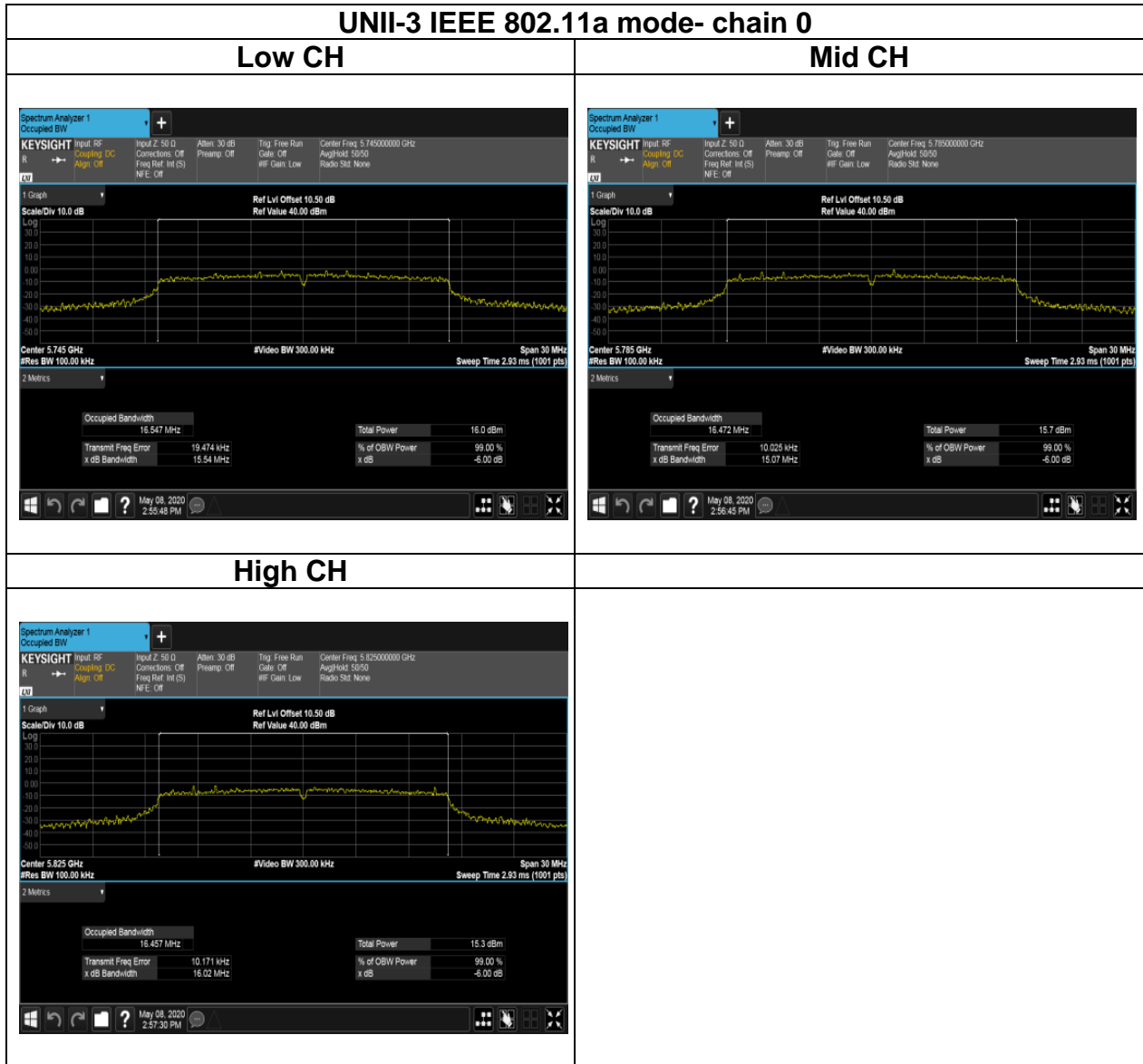

Report No.: T200504W06-RP4

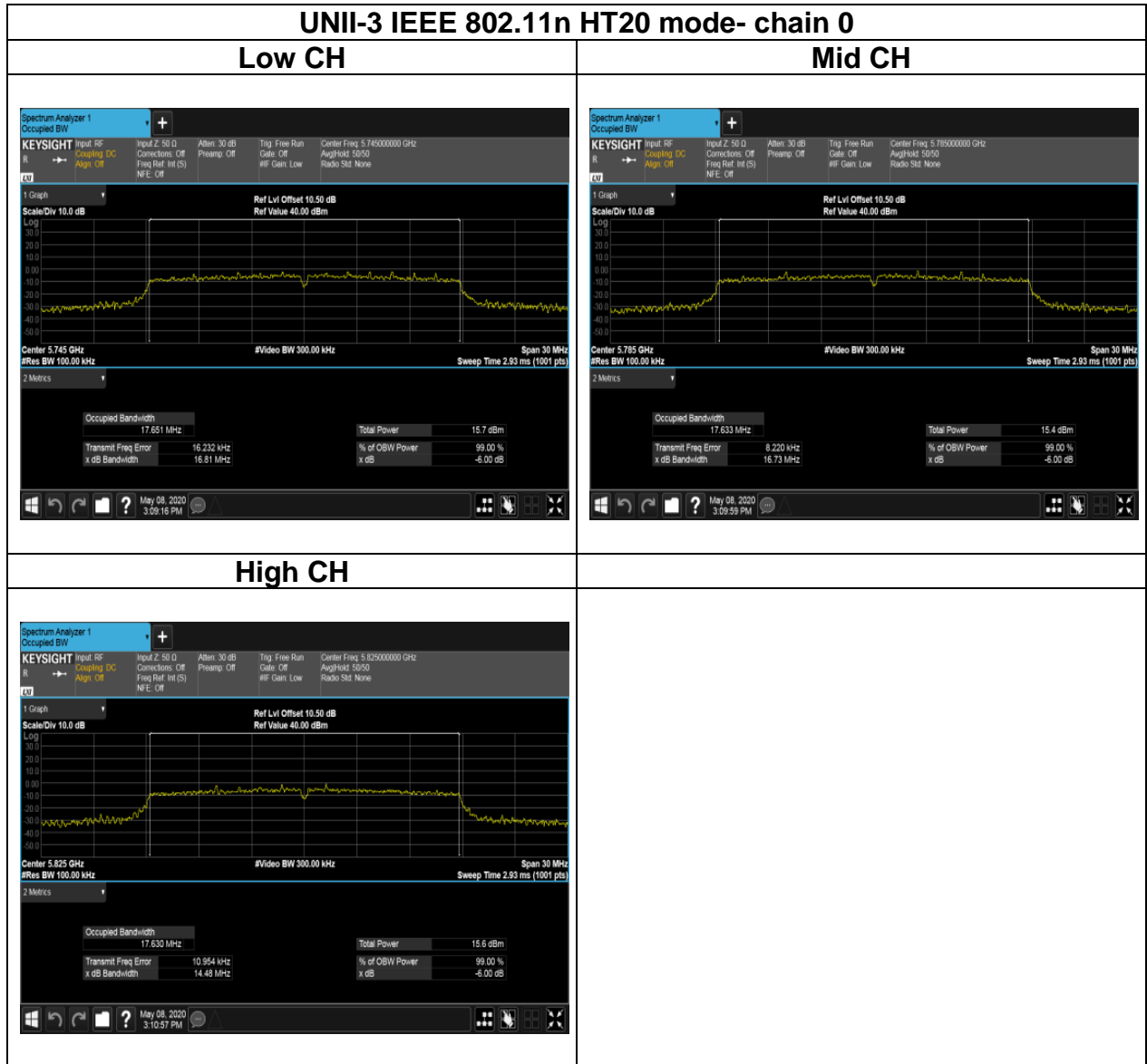

Report No.: T200504W06-RP4

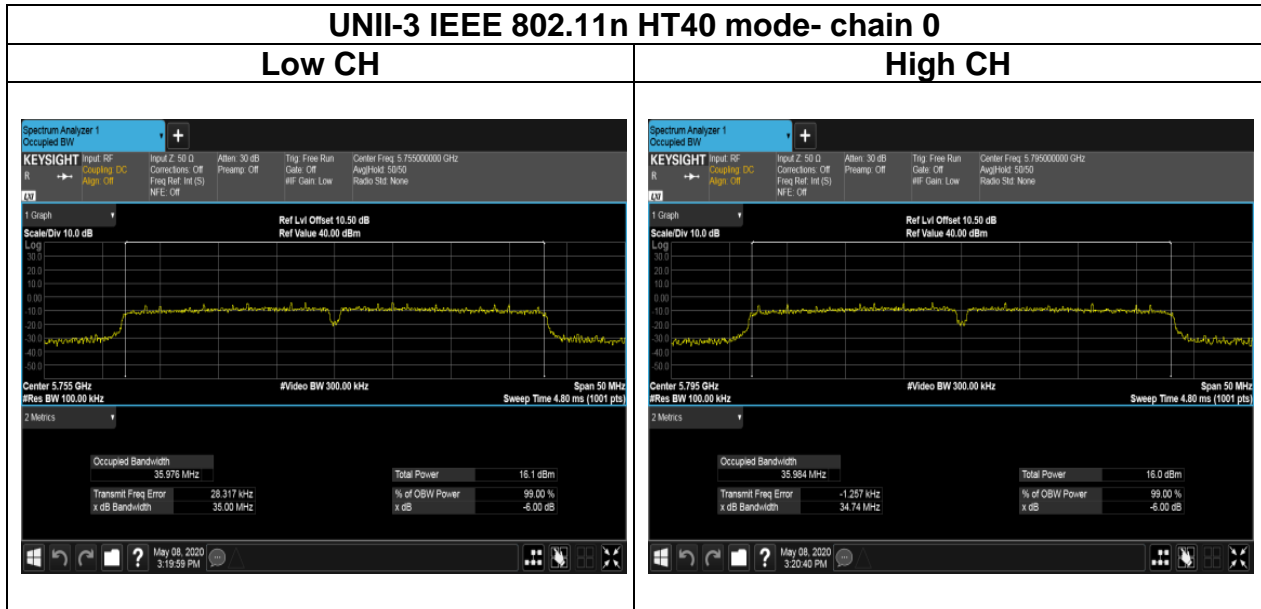

Report No.: T200504W06-RP4

4.3 OUTPUT POWER MEASUREMENT

4.3.1 Test Limit

According to §15.407 (a)(1), 15.407(a)(2) and 15.407(a)(3), and RSS-247 section 6.2.1.1, section 6.2.2.1, section 6.2.3.1 and section 6.2.4.1

FCC:

UNII-1 :

For client devices in the 5.15-5.25 GHz band, the maximum conducted output power over the frequency band of operation shall not exceed 250 mW(24 dBm), whichever power is less. B is the 99% emission bandwidth in megahertz, provided the maximum antenna gain does not exceed 6 dBi. In addition, the maximum power spectral density shall not exceed 11 dBm in any 1 megahertz band. If transmitting antennas of directional gain greater than 6 dBi are used, both the maximum conducted output power and the maximum power spectral density shall be reduced by the amount in dB that the directional gain of the antenna exceeds 6 dBi.

UNII-2a and 2c:

the maximum conducted output power over the frequency bands of operation shall not exceed the lesser of 250 mW or $11 \text{ dBm} + 10 \log B$, where B is the 26 dB emission bandwidth in megahertz. In addition, the maximum power spectral density shall not exceed 11 dBm in any 1 megahertz band. and The maximum e.i.r.p. shall not exceed 1.0 W or $17 + 10 \log B$, dBm, whichever power is less. B is the 99% emission bandwidth in MHz. If transmitting antennas of directional gain greater than 6 dBi are used, both the maximum conducted output power and the maximum power spectral density shall be reduced by the amount in dB that the directional gain of the antenna exceeds 6 dBi.

UNII-3:

For the band 5.725-5.85 GHz, the maximum conducted output power over the frequency band of operation shall not exceed 1 W. In addition, the maximum power spectral density shall not exceed 30 dBm in any 500-kHz band. If transmitting antennas of directional gain greater than 6 dBi are used, both the maximum conducted output power and the maximum power spectral density shall be reduced by the amount in dB that the directional gain of the antenna exceeds 6 dBi.

Report No.: T200504W06-RP4

IC:**UNII-1 :**

For OEM devices installed in vehicles, the maximum e.i.r.p. shall not exceed 30 mW or $1.76 + 10 \log_{10} B$, dBm, whichever is less. Devices shall implement transmitter power control (TPC) in order to have the capability to operate at least 3 dB below the maximum permitted e.i.r.p. of 30 mW.

For other devices, the maximum e.i.r.p. shall not exceed 200 mW or $10 + 10 \log_{10} B$, dBm, whichever power is less. B is the 99% emission bandwidth in megahertz. The e.i.r.p. spectral density shall not exceed 10 dBm in any 1.0 MHz band.

UNII-2a and 2c:

For OEM devices installed in vehicles, the maximum e.i.r.p. shall not exceed 30 mW or $1.76 + 10 \log_{10} B$, dBm, whichever is less. Devices shall implement TPC in order to have the capability to operate at least 3 dB below the maximum permitted e.i.r.p. of 30 mW.

Devices, other than devices installed in vehicles, shall comply with the following:

The maximum conducted output power shall not exceed 250 mW or $11 + 10 \log_{10} B$, dBm, whichever is less. The power spectral density shall not exceed 11 dBm in any 1.0 MHz band;

The maximum e.i.r.p. shall not exceed 1.0 W or $17 + 10 \log_{10} B$, dBm, whichever is less. B is the 99% emission bandwidth in megahertz. Note that devices with a maximum e.i.r.p. greater than 500 mW shall implement TPC in order to have the capability to operate at least 6 dB below the maximum permitted e.i.r.p. of 1 W.

UNII-2c (5470-5600 MHz and 5650-5725 MHz)

The maximum conducted output power shall not exceed 250 mW or $11 + 10 \log_{10} B$, dBm, whichever is less. The power spectral density shall not exceed 11 dBm in any 1.0 MHz band.

The maximum e.i.r.p. shall not exceed 1.0 W or $17 + 10 \log_{10} B$, dBm, whichever is less. B is the 99% emission bandwidth in megahertz. Note that devices with a maximum e.i.r.p. greater than 500 mW shall implement TPC in order to have the capability to operate at least 6 dB below the maximum permitted e.i.r.p. of 1 W.

UNII-3:

For the band 5.725-5.85 GHz, the maximum conducted output power over the frequency band of operation shall not exceed 1 W. In addition, the maximum power spectral density shall not exceed 30 dBm in any 500-kHz band. If transmitting antennas of directional gain greater than 6 dBi are used, both the maximum conducted output power and the maximum power spectral density shall be reduced by the amount in dB that the directional gain of the antenna exceeds 6 dBi.

Report No.: T200504W06-RP4

UNII-1 Limit	<input checked="" type="checkbox"/> Antenna not exceed 6 dBi : 24dBm <input type="checkbox"/> Antenna with DG greater than 6 dBi : [Limit = 24 – (DG – 6)]
UNII-2a/2c Limit	<input checked="" type="checkbox"/> Antenna not exceed 6 dBi : 24dBm <input type="checkbox"/> Antenna with DG greater than 6 dBi : [Limit = 24 – (DG – 6)]
UNII-3 Limit	<input checked="" type="checkbox"/> Antenna not exceed 6 dBi : 30dBm <input type="checkbox"/> Antenna with DG greater than 6 dBi : [Limit = 30 – (DG – 6)]

4.3.2 Test Procedure

Test method Refer as KDB 789033 D02, Section E.3.b for BW 20MHz and 40MHz, E.2.b for BW 80MHz.

1. The EUT RF output connected to the power meter or spectrum by RF cable.
2. Setting maximum power transmit of EUT.
3. The path loss was compensated to the results for each measurement.
4. Measure and record the result of Average output power. in the test report.

4.3.3 Test Setup

For BW 20MHz and 40MHz

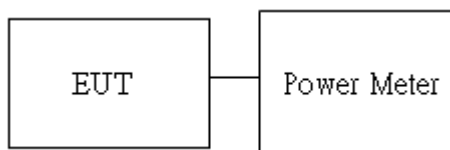

For BW 80MHz

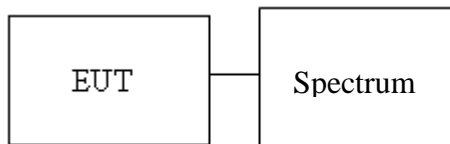

Report No.: T200504W06-RP4

4.3.4 Test Result

Conducted output power :

UNII-1										
Config	CH	Freq. (MHz)	Power Set	AV Power (dBm)	EIRP AV Total Power (dBm)	AV Total Power (W)	EIRP AV Total Power (W)	DG (dBi)	Limit (dBm)	EIRP Limit (dBm)
IEEE 802.11a Data rate: 6Mbps	36	5180	17.0	15.73	17.77	0.0374	0.0599	2.04	24	23
	44	5220	17.0	15.78	17.82	0.0379	0.0605			
	48	5240	17.0	15.84	17.88	0.0384	0.0614			
IEEE 802.11n HT20 Data rate: MCS0	36	5180	17.0	15.63	17.67	0.0365	0.0585			
	44	5220	17.0	15.71	17.75	0.0372	0.0595			
	48	5240	17.0	15.84	17.88	0.0384	0.0614			
IEEE 802.11n HT40 Data rate: MCS0	38	5190	13.5	11.75	13.79	0.0150	0.0239			
	46	5230	17.0	15.37	17.41	0.0344	0.0551			

Report No.: T200504W06-RP4

UNII-2a										
Config	CH	Freq. (MHz)	Power Set	AV Power (dBm)	EIRP AV Total Power (dBm)	AV Total Power (W)	EIRP AV Total Power (W)	DG (dBi)	Limit (dBm)	EIRP Limit (dBm)
IEEE 802.11a Data rate: 6Mbps	52	5260	17	15.14	17.18	0.0327	0.0523	2.04	24	30
	56	5280	17	15.52	17.56	0.0357	0.0570			
	64	5320	17	15.69	17.73	0.0371	0.0593			
IEEE 802.11n HT20 Data rate: MCS0	52	5260	17	15.11	17.15	0.0324	0.0519			
	56	5280	17	15.12	17.16	0.0325	0.0520			
	64	5320	17	15.60	17.64	0.0363	0.0581			
IEEE 802.11n HT40 Data rate: MCS0	54	5270	17	15.74	17.78	0.0375	0.0600			
	62	5310	14	12.51	14.55	0.0178	0.0285			

Report No.: T200504W06-RP4

UNII-2c										
Config	CH	Freq. (MHz)	Power Set	AV Power (dBm)	EIRP AV Total Power (dBm)	AV Total Power (W)	EIRP AV Total Power (W)	DG (dBi)	Limit (dBm)	EIRP Limit (dBm)
IEEE 802.11a Data rate: 6Mbps	100	5500	17	15.51	17.55	0.0356	0.0569	2.04	24	30
	116	5580	17	16.05	18.09	0.0403	0.0644			
	140	5700	16	14.76	16.80	0.0299	0.0479			
IEEE 802.11n HT20 Data rate: MCS0	100	5500	17	15.46	17.50	0.0352	0.0562			
	116	5580	17	16.01	18.05	0.0399	0.0638			
	140	5700	14	13.86	15.90	0.0243	0.0389			
IEEE 802.11n HT40 Data rate: MCS0	102	5510	12	11.16	13.20	0.0131	0.0209			
	110	5550	17	16.07	18.11	0.0405	0.0647			
	134	5670	13	11.96	14.00	0.0157	0.0251			

Report No.: T200504W06-RP4

UNII-3									
Config	CH	Freq. (MHz)	Power Set	AV Power (dBm)	EIRP AV Total Power (dBm)	AV Total Power (W)	EIRP AV Total Power (W)	DG (dBi)	Limit (dBm)
IEEE 802.11a Data rate: 6Mbps	149	5745	13	11.29	13.33	0.0135	0.0215	2.04	30
	157	5785	13	11.23	13.27	0.0133	0.0212		
	165	5825	13	10.94	12.98	0.0124	0.0199		
IEEE 802.11n HT20 Data rate: MCS0	149	5745	13	11.32	13.36	0.0136	0.0217		
	157	5785	13	11.10	13.14	0.0129	0.0206		
	165	5825	13	11.06	13.10	0.0128	0.0204		
IEEE 802.11n HT40 Data rate: MCS0	151	5755	13	11.08	13.12	0.0128	0.0205		
	159	5795	13	11.11	13.15	0.0129	0.0207		

Report No.: T200504W06-RP4

4.4 POWER SPECTRAL DENSITY

4.4.1 Test Limit

According to §15.407 (a)(1), 15.407(a)(2) and 15.407(a)(3)

According to RSS-247 section 6.2.1.1, section 6.2.2.1, section 6.2.3.1 and section 6.2.4.1

UNII-1:

FCC: The maximum power spectral density shall not exceed 11 dBm in any 1 megahertz band.

IC: The e.i.r.p. spectral density shall not exceed 10 dBm in any 1.0 MHz band.

If transmitting antennas of directional gain greater than 6 dBi are used, both the maximum conducted output power and the maximum power spectral density shall be reduced by the amount in dB that the directional gain of the antenna exceeds 6 dBi.

UNII-2a and 2c:

The maximum power spectral density shall not exceed 11 dBm in any 1 megahertz band.

If transmitting antennas of directional gain greater than 6 dBi are used, both the maximum conducted output power and the maximum power spectral density shall be reduced by the amount in dB that the directional gain of the antenna exceeds 6 dBi.

UNII-3:

For the band 5.725-5.85 GHz, the maximum conducted output power over the frequency band of operation shall not exceed 1 W. In addition, the maximum power spectral density shall not exceed 30 dBm in any 500-kHz band. If transmitting antennas of directional gain greater than 6 dBi are used, both the maximum conducted output power and the maximum power spectral density shall be reduced by the amount in dB that the directional gain of the antenna exceeds 6 dBi.

UNII-1 Limit	<input checked="" type="checkbox"/> Antenna not exceed 6 dBi : 11 dBm <input type="checkbox"/> Antenna with DG greater than 6 dBi : [Limit = 11 – (DG – 6)]
UNII-2a Limit	<input checked="" type="checkbox"/> Antenna not exceed 6 dBi : 11 dBm <input type="checkbox"/> Antenna with DG greater than 6 dBi : [Limit = 11 – (DG – 6)]
UNII-2c Limit	<input checked="" type="checkbox"/> Antenna not exceed 6 dBi : 11 dBm <input type="checkbox"/> Antenna with DG greater than 6 dBi : [Limit = 11 – (DG – 6)]
UNII-3 Limit	<input checked="" type="checkbox"/> Antenna not exceed 6 dBi : 30 dBm <input type="checkbox"/> Antenna with DG greater than 6 dBi : [Limit = 30 – (DG – 6)]

4.4.2 Test Procedure

Test method Refer as KDB 789033 D02

1. The EUT RF output connected to the spectrum analyzer by RF cable.
2. Setting maximum power transmit of EUT
3. UNII-1, UNII-2a and UNII-2c, SA set RBW = 1MHz, VBW = 3MHz and Detector = RMS, to measurement Power Density.
4. UNII-3, SA set RBW = 500kHz, VBW = 2MHz and Detector = RMS, to measurement Power Density
5. The path loss and Duty Factor were compensated to the results for each measurement by SA.
6. Mark the maximum level.
7. Measure and record the result of power spectral density. in the test report.

4.4.3 Test Setup

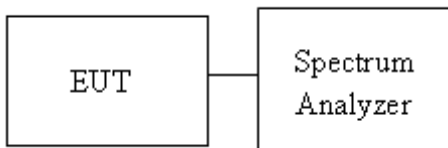

4.4.4 Test Result

UNII-1 5150-5250 MHz							
Test mode: IEEE 802.11a mode							
Channel	Frequency (MHz)	Chain 0 PPSD (dBm)	Chain 1 PPSD (dBm)	Total PPSD (dBm)	EIRP Total PPSD (dBm)	FCC Limit (dBm)	IC Limit (dBm)
Low	5180	-0.413	-	-0.413	1.627	11	10
Mid	5220	-1.458	-	-1.458	0.582		
High	5240	-1.974	-	-1.974	0.066		
Test mode: IEEE 802.11n HT20 mode							
Channel	Frequency (MHz)	Chain 0 PPSD (dBm)	Chain 1 PPSD (dBm)	Total PPSD (dBm)	EIRP Total PPSD (dBm)	FCC Limit (dBm)	IC Limit (dBm)
Low	5180	-1.357	-	-1.357	0.683	11	10
Mid	5220	-1.682	-	-1.682	0.358		
High	5240	-2.786	-	-2.786	-0.746		
Test mode: IEEE 802.11n HT40 mode							
Channel	Frequency (MHz)	Chain 0 PPSD (dBm)	Chain 1 PPSD (dBm)	Total PPSD (dBm)	EIRP Total PPSD (dBm)	FCC Limit (dBm)	IC Limit (dBm)
Low	5190	-5.125	-	-5.125	-3.085	11	10
High	5230	-5.071	-	-5.071	-3.031		

UNII-2a 5250-5350 MHz					
Test mode: IEEE 802.11a mode					
Channel	Frequency (MHz)	Chain 0 PPSD (dBm)	Chain 1 PPSD (dBm)	Total PPSD (dBm)	Limit (dBm)
Low	5260	-2.321	-	-2.321	11
Mid	5280	-1.274	-	-1.274	
High	5320	-2.246	-	-2.246	
Test mode: IEEE 802.11n HT20 mode					
Channel	Frequency (MHz)	Chain 0 PPSD (dBm)	Chain 1 PPSD (dBm)	Total PPSD (dBm)	Limit (dBm)
Low	5260	-0.861	-	-0.861	11
Mid	5280	-2.823	-	-2.823	
High	5320	-2.178	-	-2.178	
Test mode: IEEE 802.11n HT40 mode					
Channel	Frequency (MHz)	Chain 0 PPSD (dBm)	Chain 1 PPSD (dBm)	Total PPSD (dBm)	Limit (dBm)
Low	5270	-6.127	-	-6.127	11
High	5310	-5.895	-	-5.895	

UNII-2c 5470-5725 MHz					
Test mode: IEEE 802.11a mode					
Channel	Frequency (MHz)	Chain 0 PPSD (dBm)	Chain 1 PPSD (dBm)	Total PPSD (dBm)	Limit (dBm)
Low	5500	-1.417	-	-1.417	11
Mid	5580	-0.833	-	-0.833	
High	5700	-1.994	-	-1.994	
Test mode: IEEE 802.11n HT20 mode					
Channel	Frequency (MHz)	Chain 0 PPSD (dBm)	Chain 1 PPSD (dBm)	Total PPSD (dBm)	Limit (dBm)
Low	5500	-1.488	-	-1.488	11
Mid	5580	-1.752	-	-1.752	
High	5700	-2.074	-	-2.074	
Test mode: IEEE 802.11n HT40 mode					
Channel	Frequency (MHz)	Chain 0 PPSD (dBm)	Chain 1 PPSD (dBm)	Total PPSD (dBm)	Limit (dBm)
Low	5510	-4.561	-	-4.561	11
Mid	5550	-4.908	-	-4.908	
High	5670	-5.611	-	-5.611	

Report No.: T200504W06-RP4

UNII-3 5725-5825 MHz					
Test mode: IEEE 802.11a mode					
Channel	Frequency (MHz)	Chain 0 PPSD (dBm)	Chain 1 PPSD (dBm)	Total PPSD (dBm)	Limit (dBm)
Low	5745	3.94	-	3.94	30
Mid	5785	3.2	-	3.2	
High	5825	4.08	-	4.08	
Test mode: IEEE 802.11n HT20 mode					
Channel	Frequency (MHz)	Chain 0 PPSD (dBm)	Chain 1 PPSD (dBm)	Total PPSD (dBm)	Limit (dBm)
Low	5745	3.01	-	3.01	30
Mid	5785	2.93	-	2.93	
High	5825	3.36	-	3.36	
Test mode: IEEE 802.11n HT40 mode					
Channel	Frequency (MHz)	Chain 0 PPSD (dBm)	Chain 1 PPSD (dBm)	Total PPSD (dBm)	Limit (dBm)
Low	5755	0.59	-	0.59	30
High	5795	1.33	-	1.33	

Report No.: T200504W06-RP4

Test Data

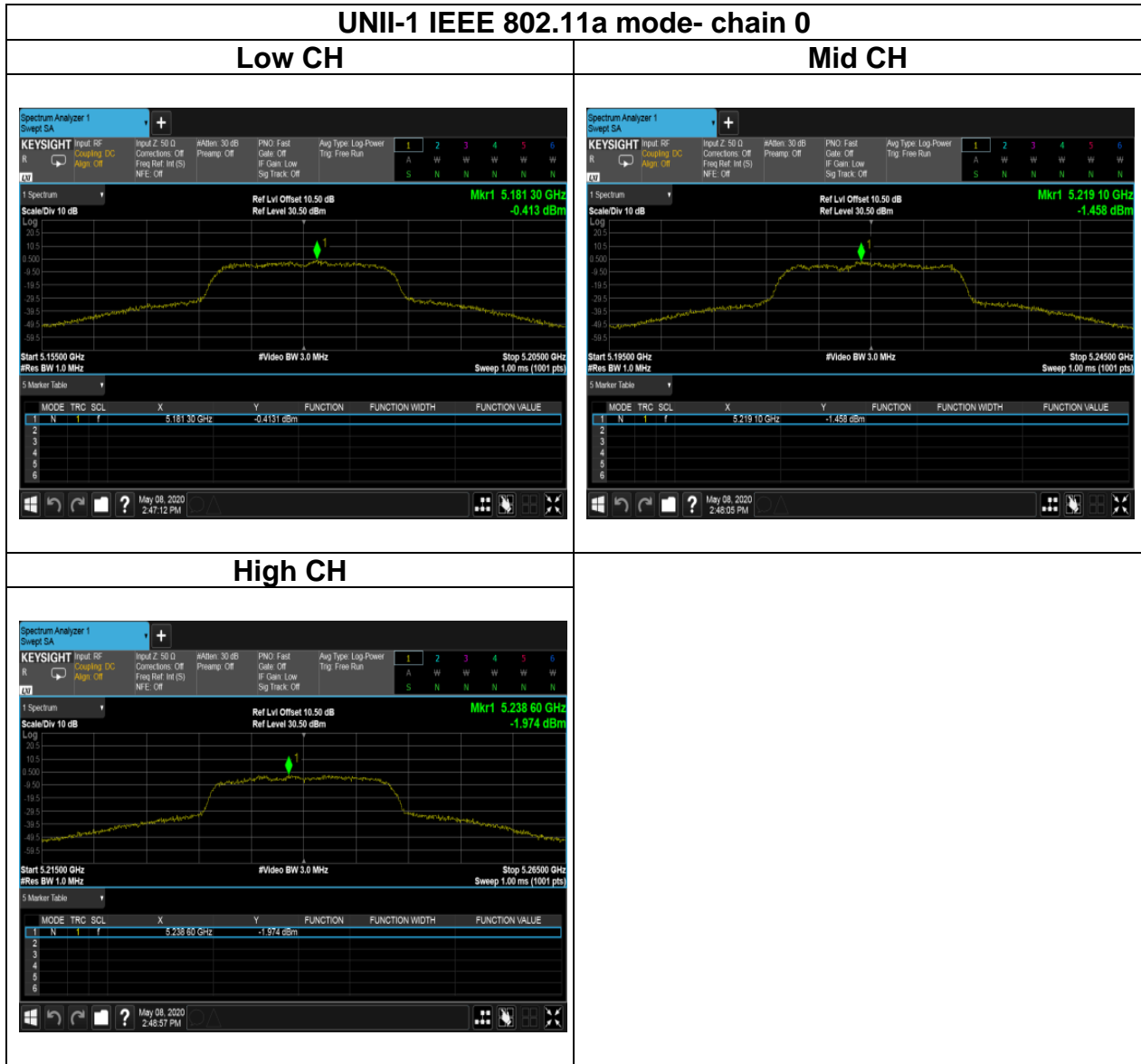

Report No.: T200504W06-RP4

UNII-1 IEEE 802.11n HT20 mode- chain 0

Low CH



Mid CH



High CH



Report No.: T200504W06-RP4

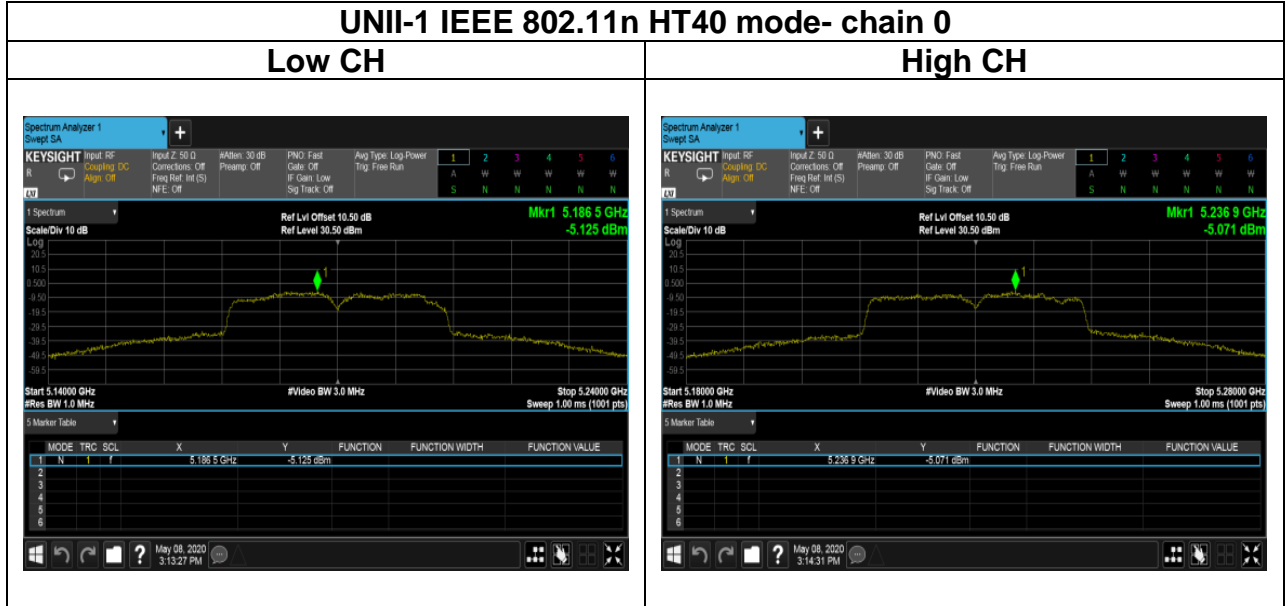

Report No.: T200504W06-RP4

Test Data

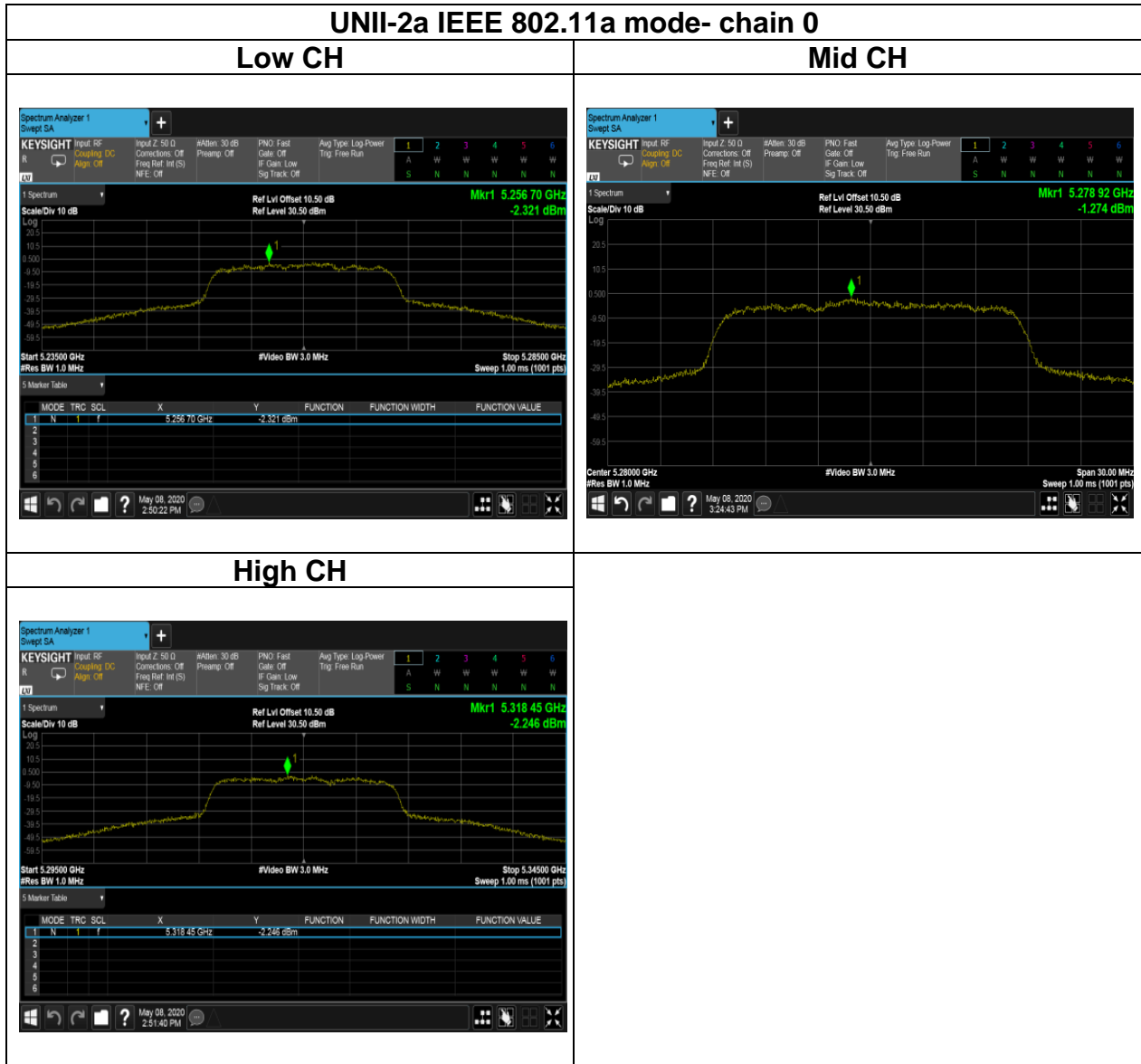

Report No.: T200504W06-RP4

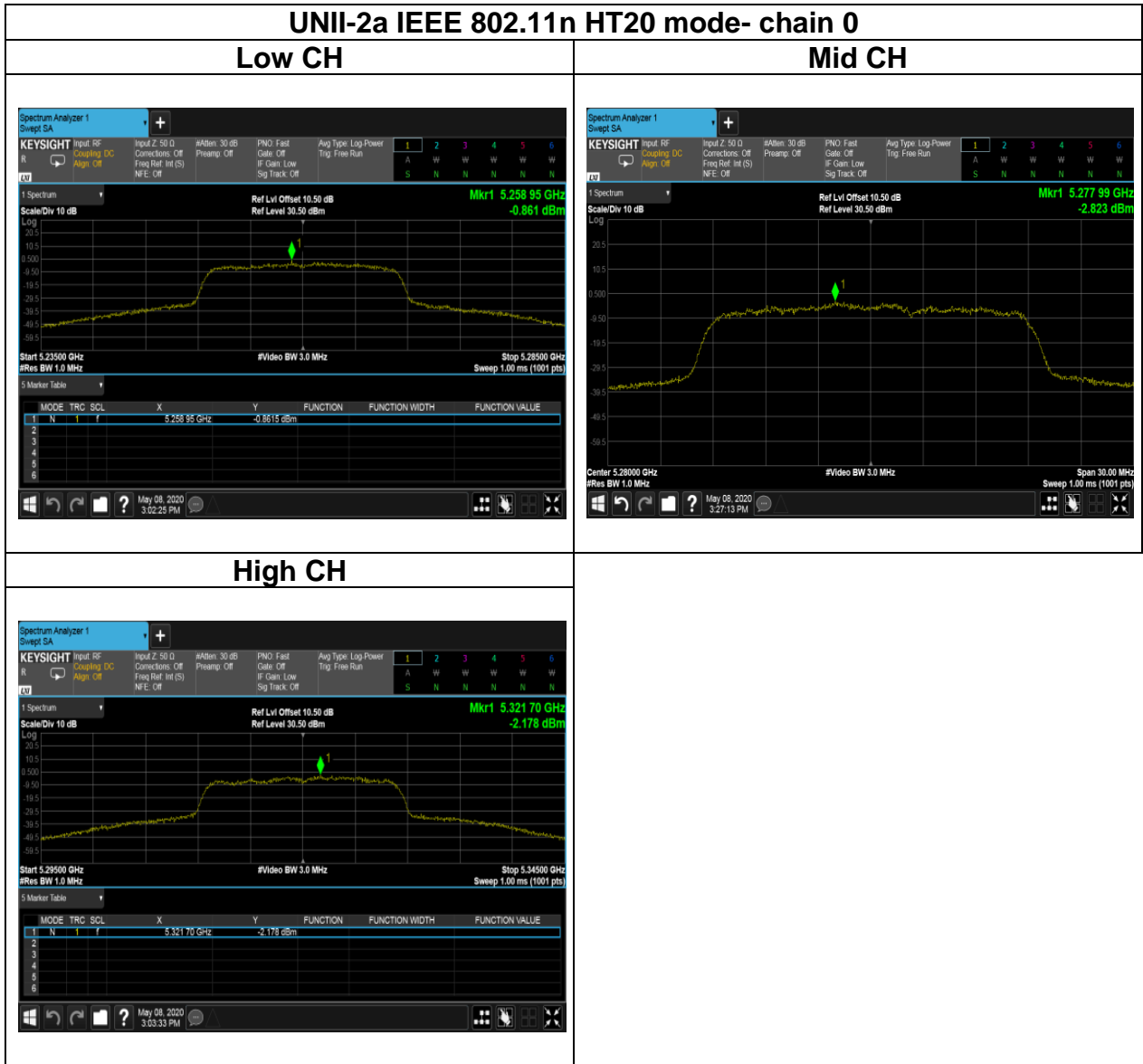

Report No.: T200504W06-RP4

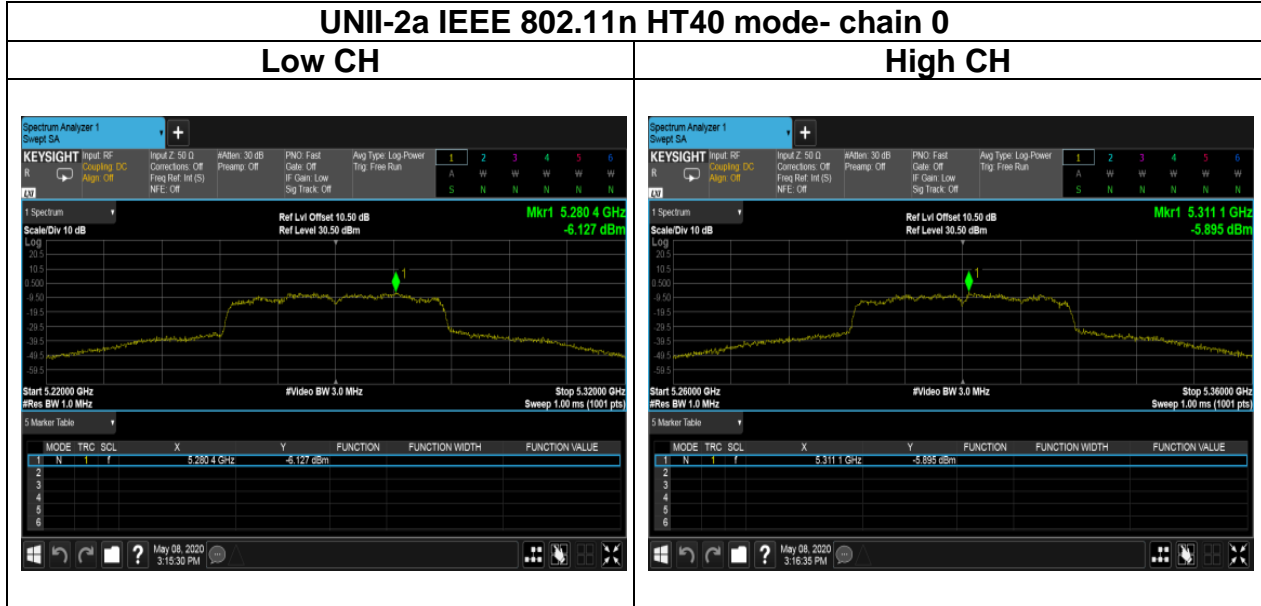

Report No.: T200504W06-RP4

Test Data

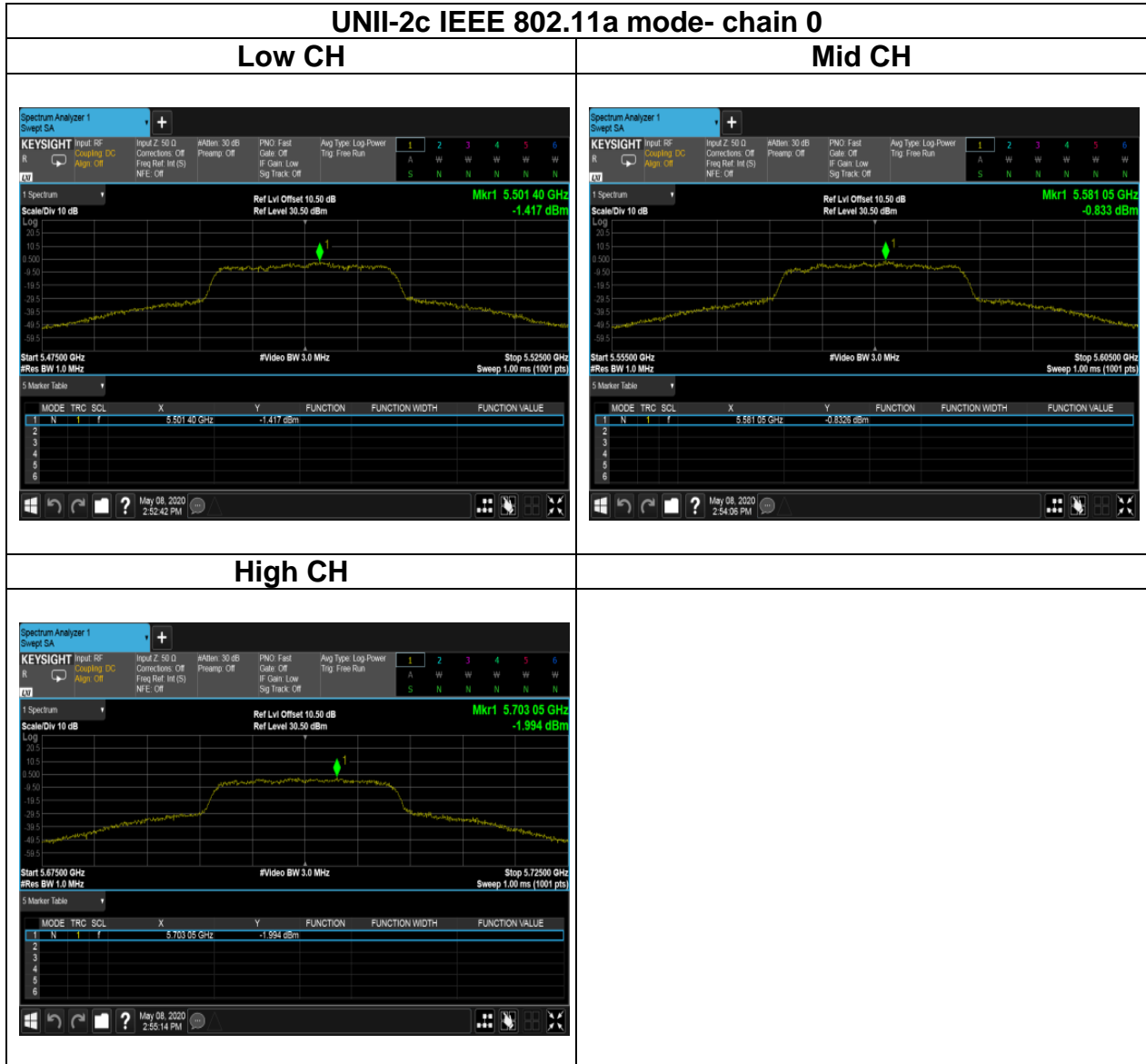

Report No.: T200504W06-RP4

UNII-2c IEEE 802.11n HT20 mode- chain 0

Low CH



Mid CH

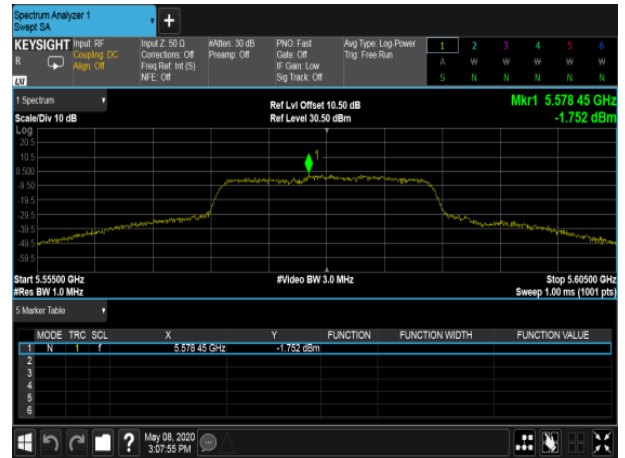

High CH



Report No.: T200504W06-RP4

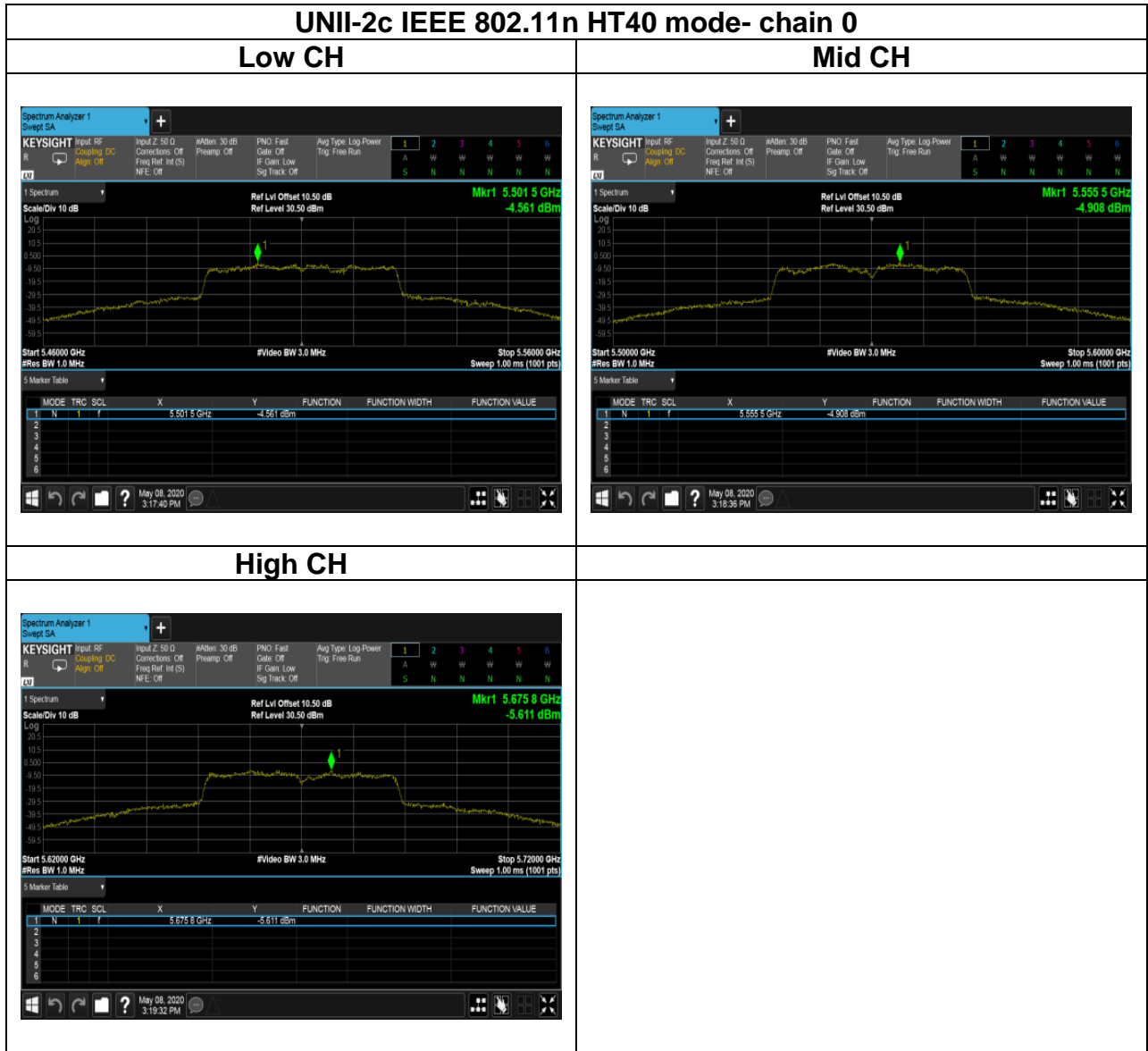

Report No.: T200504W06-RP4

Test Data

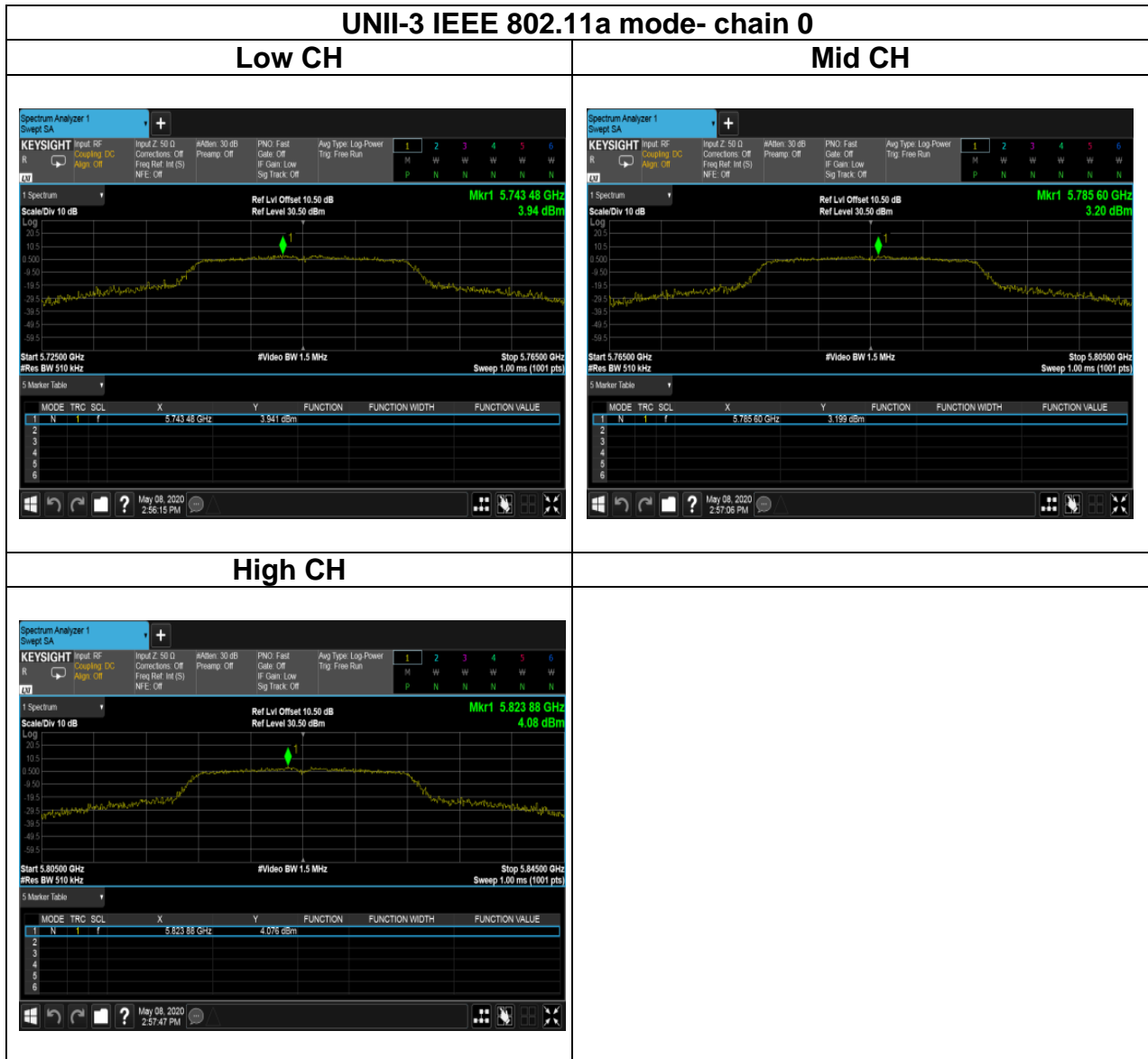

Report No.: T200504W06-RP4

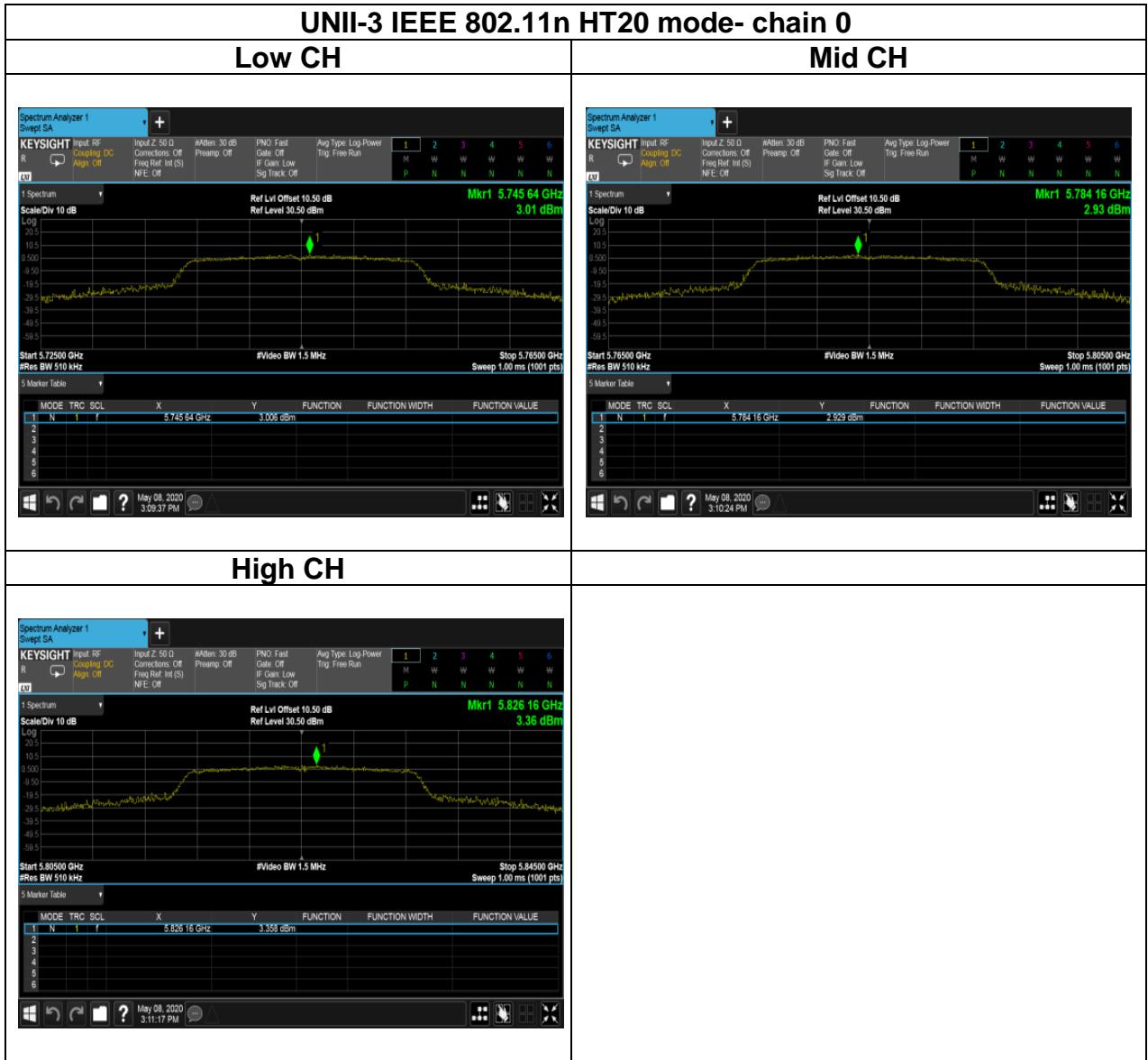

Report No.: T200504W06-RP4

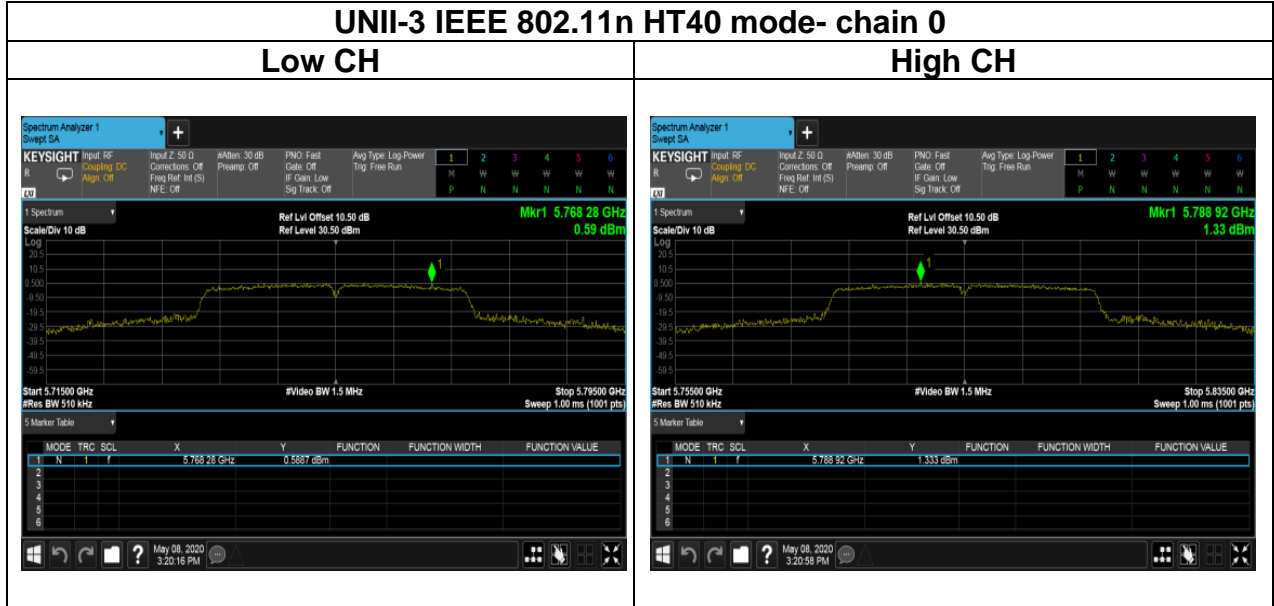

4.5 RADIATION BANDEDGE AND SPURIOUS EMISSION

4.5.1 Test Limit

According to §15.407, §15.209 and §15.205,
 According to RSS-247 section 6.2.1.2 and section 6.2.4.2

Below 30 MHz

Frequency	Field Strength (microvolts/m)	Magnetic H-Field (microamperes/m)	Measurement Distance (metres)
9-490 kHz	2,400/F (F in kHz)	2,400/F (F in kHz)	300
490-1,705 kHz	24,000/F (F in kHz)	24,000/F (F in kHz)	30
1.705-30 MHz	30	N/A	30

Above 30 MHz

Frequency (MHz)	Field Strength microvolts/m at 3 metres (watts, e.i.r.p.)	
	Transmitters	Receivers
30-88	100 (3 nW)	100 (3 nW)
88-216	150 (6.8 nW)	150 (6.8 nW)
216-960	200 (12 nW)	200 (12 nW)
Above 960	500 (75 nW)	500 (75 nW)

RSS-Gen Table 3 and Table 5 – General Field Strength Limits for Transmitters and Receivers at Frequencies Above 30 MHz ^(Note)

Frequency (MHz)	Field Strength microvolts/m at 3 metres (watts, e.i.r.p.)	
	Transmitters	Receivers
30-88	100 (3 nW)	100 (3 nW)
88-216	150 (6.8 nW)	150 (6.8 nW)
216-960	200 (12 nW)	200 (12 nW)
Above 960	500 (75 nW)	500 (75 nW)

Note: Measurements for compliance with the limits in table 3 may be performed at distances other than 3 metres, in accordance with Section 6.6.

RSS-Gen Table 6: General Field Strength Limits for Transmitters at Frequencies Below 30 MHz (Transmit)

Frequency	Magnetic field strength (H-Field) ($\mu\text{A/m}$)	Measurement Distance (m)
9-490 kHz ^{Note}	6.37/F (F in kHz)	300
490-1,705 kHz	63.7/F (F in kHz)	30
1.705-30 MHz	0.08	30

Note: The emission limits for the ranges 9-90 kHz and 110-490 kHz are based on measurements employing a linear average detector..

UNII-1 :

For transmitters operating in the band 5150-5250 MHz, all emissions outside the band 5150-5350 MHz shall not exceed -27 dBm/MHz e.i.r.p. However, any unwanted emissions that fall into the band 5250-5350 MHz must be 26 dBc, when measured using a resolution bandwidth between 1 and 5% of the occupied bandwidth, above 5.25 GHz. Otherwise, the transmission is considered as intentional and the devices shall implement dynamic frequency selection (DFS) and transmitter power control (TPC) as per the requirements for the band 5250-5350 MHz

UNII-2a and 2c :

For devices with operating frequencies in the band 5250-5350 MHz but having a channel bandwidth that overlaps the band 5150-5250 MHz, the devices' unwanted emission shall not exceed -27 dBm/MHz e.i.r.p. outside the band 5150-5350 MHz and its power shall comply with the spectral power density for operation within the band 5150-5250 MHz. The device shall be labelled "for indoor use only." Emissions outside the band 5470-5725 MHz shall not exceed -27 dBm/MHz e.i.r.p.

UNII-3:

For the band 5725-5850 MHz, emissions at frequencies from the band edges to 10 MHz above or below the band edges shall not exceed -17 dBm/MHz e.i.r.p.
For emissions at frequencies more than 10 MHz above or below the band edges, the emissions power shall not exceed -27 dBm/MHz

4.5.2 Test Procedure

Test method Refer as KDB 789033 D02.

1. The EUT is placed on a turntable, Above 1 GHz is 1.5m and below 1 GHz is 0.8m above ground plane. The EUT Configured un accordance with ANSI C63.10: 2013, and the EUT set in a continuous mode.
2. The turntable shall be rotated for 360 degrees to determine the position of maximum emission level. And EUT is set 3m away from the receiving antenna, which is scanned from 1m to 4m above the ground plane to find out the highest emissions. Measurement are made polarized in both the vertical and the horizontal positions with antenna.
3. Span shall wide enough to full capture the emission measured. The SA from 9kHz to 26.5GHz set to the low, Mid and High channels with the EUT transmit.
4. No emission found between lowest internal used/generated frequency to 30MHz (9KHz~30MHz)
5. The SA setting following :
 - (1) Below 1G : RBW = 100kHz, VBW \geq 3*RBW, Sweep = Auto, Detector = Peak, Trace = Max hold.
 - (2) Above 1G :
 - (2.1) For Peak measurement : RBW = 1MHz, VBW \geq 3 RBW, Sweep = Auto, Detector = Peak, Trace = Max hold.
 - (2.2) For Average measurement : RBW = 1MHz, VBW
 - If Duty Cycle \geq 98%, VBW=10Hz.
 - If Duty Cycle < 98%, VBW=1/T.

4.5.3 Test Setup

9kHz ~ 30MHz

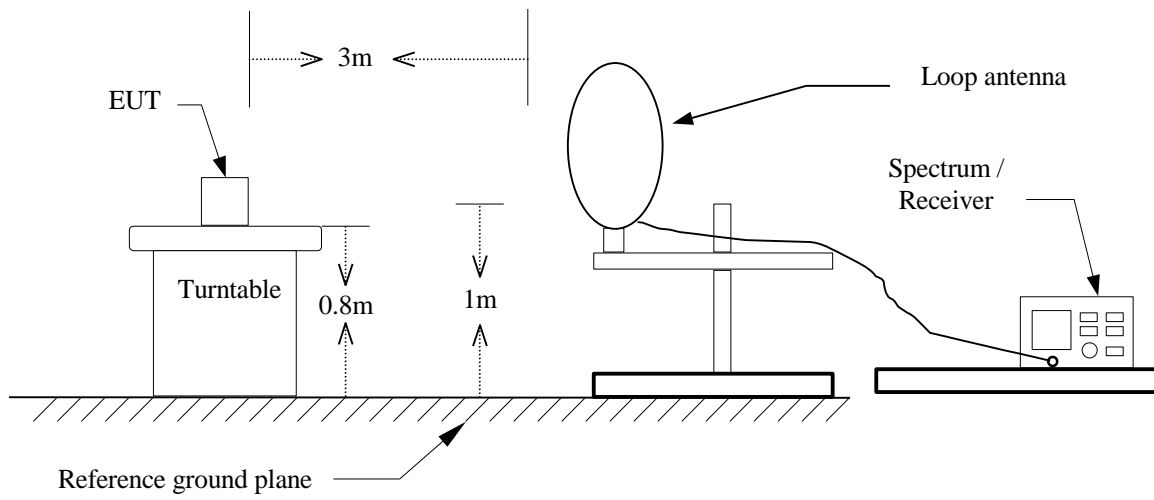

30MHz ~ 1GHz

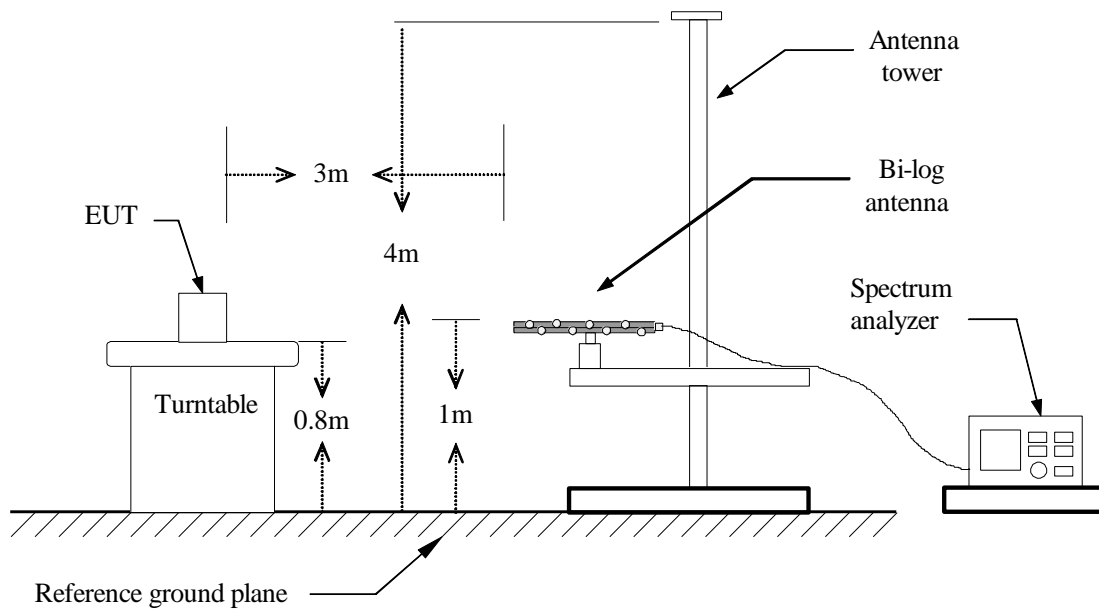

Above 1 GHz

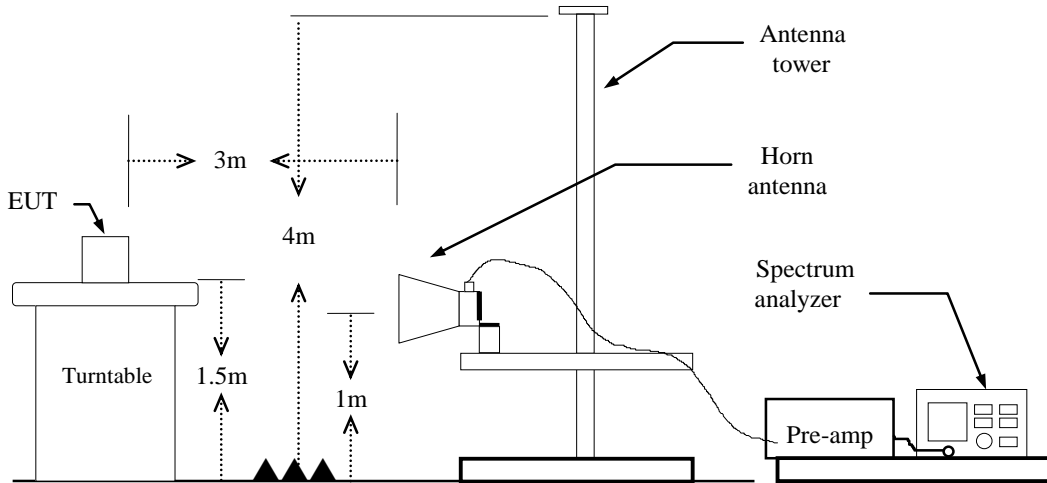

4.5.4 Test Result

Band Edge Test Data

Test Data for UNII-1

Test Mode	IEEE 802.11a / 5180MHZ	Temp/Hum	23.6(°C)/ 45%RH
Test Item	Band Edge	Test Date	May 14, 2020
Polarize	Vertical	Test Engineer	Jerry Chang
Detector	Peak and Average		

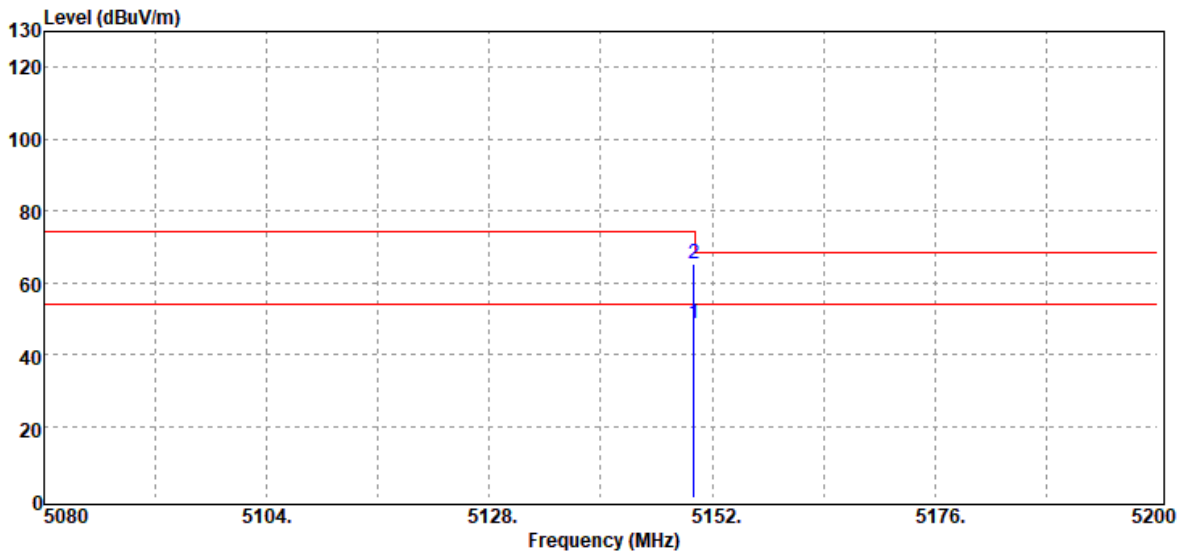

Frequency (MHz)	Detector Mode PK/QP/AV	Spectrum Reading Level dBμV	Factor dB	Actual FS dBμV/m	Limit @3m dBμV/m	Margin dB
5150.00	Average	43.20	5.58	48.78	54.00	-5.22
5150.00	Peak	59.82	5.58	65.40	74.00	-8.60

Report No.: T200504W06-RP4

Test Mode	IEEE 802.11a / 5180MHZ	Temp/Hum	23.6(°C)/ 45%RH
Test Item	Band Edge	Test Date	May 14, 2020
Polarize	Horizontal	Test Engineer	Jerry Chang
Detector	Peak / Average		

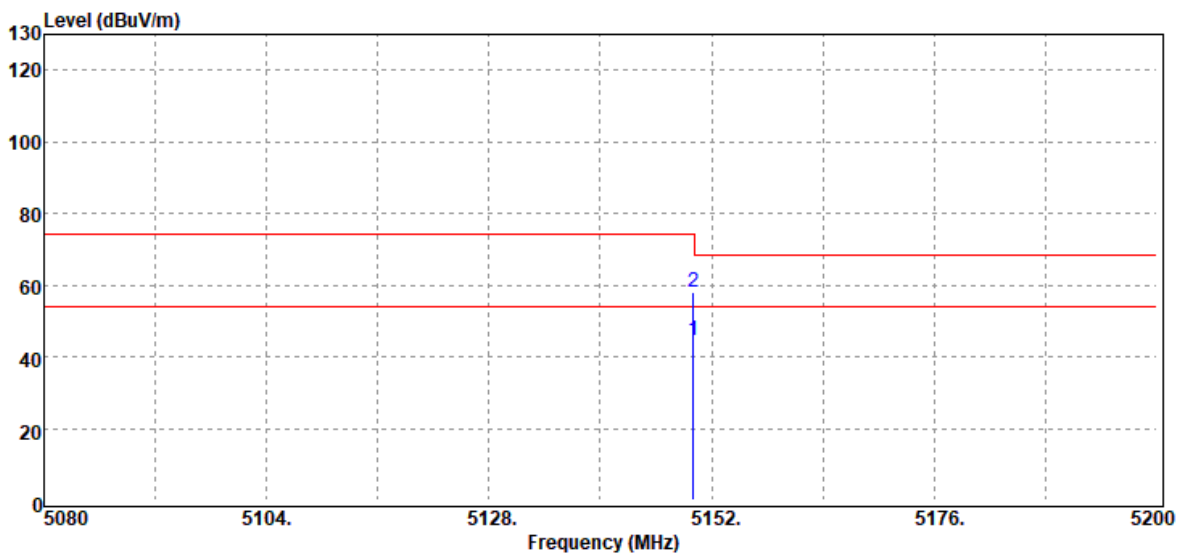

Frequency (MHz)	Detector Mode PK/QP/AV	Spectrum Reading Level dB μ V	Factor dB	Actual FS dB μ V/m	Limit @3m dB μ V/m	Margin dB
5150.00	Average	39.12	5.58	44.70	54.00	-9.30
5150.00	Peak	52.47	5.58	58.05	74.00	-15.95

Report No.: T200504W06-RP4

Test Mode	IEEE 802.11n 20 MHz / 5180MHZ	Temp/Hum	23.6(°C)/ 45%RH
Test Item	Band Edge	Test Date	May 14, 2020
Polarize	Vertical	Test Engineer	Jerry Chang
Detector	Peak and Average		

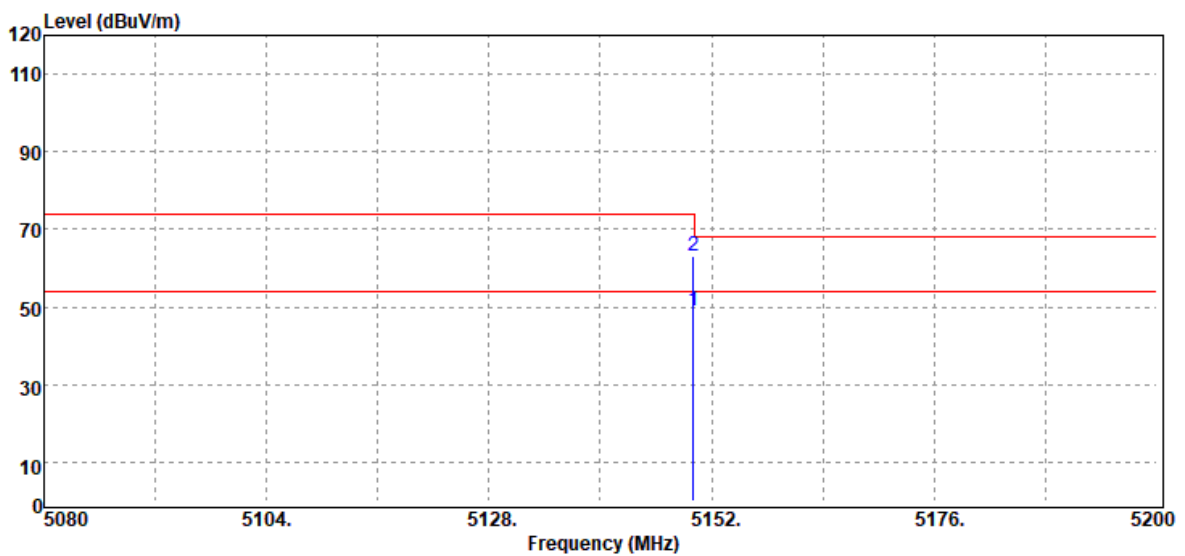

Frequency (MHz)	Detector Mode PK/QP/AV	Spectrum Reading Level dB μ V	Factor dB	Actual FS dB μ V/m	Limit @3m dB μ V/m	Margin dB
5150.00	Average	43.54	5.58	49.12	54.00	-4.88
5150.00	Peak	57.36	5.58	62.94	74.00	-11.06

Report No.: T200504W06-RP4

Test Mode	IEEE 802.11n 20 MHz / 5180MHz	Temp/Hum	23.6(°C)/ 45%RH
Test Item	Band Edge	Test Date	May 14, 2020
Polarize	Vertical	Test Engineer	Jerry Chang
Detector	Peak and Average		

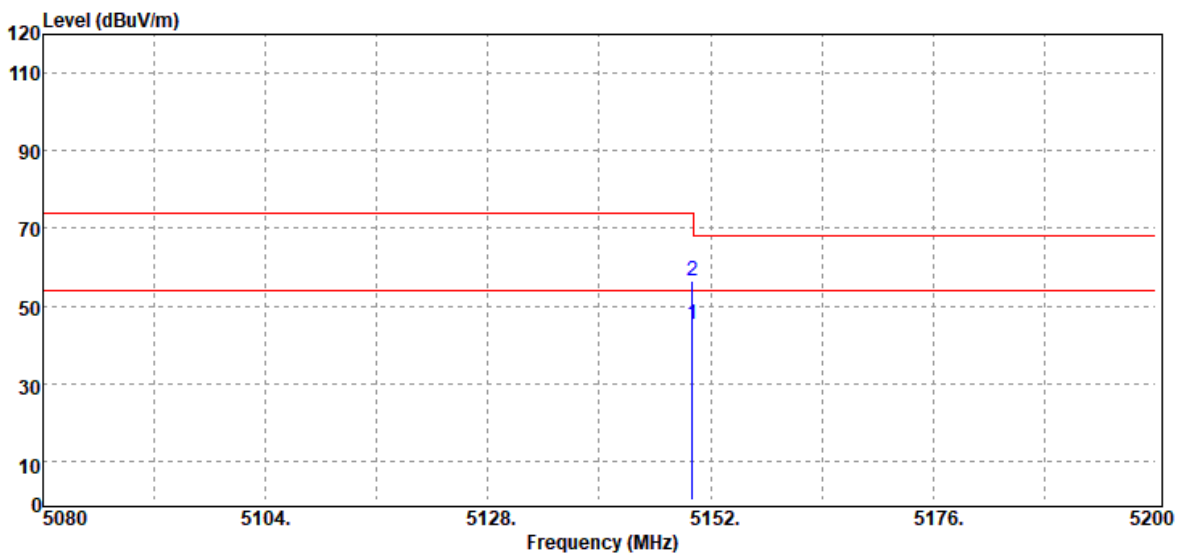

Frequency (MHz)	Detector Mode PK/QP/AV	Spectrum Reading Level dB μ V	Factor dB	Actual FS dB μ V/m	Limit @3m dB μ V/m	Margin dB
5150.00	Average	39.79	5.58	45.37	54.00	-8.63
5150.00	Peak	50.86	5.58	56.44	74.00	-17.56

Report No.: T200504W06-RP4

Test Mode	IEEE 802.11n 40 MHz / 5190MHz	Temp/Hum	23.6(°C)/ 45%RH
Test Item	Band Edge	Test Date	May 14, 2020
Polarize	Horizontal	Test Engineer	Jerry Chang
Detector	Peak and Average		

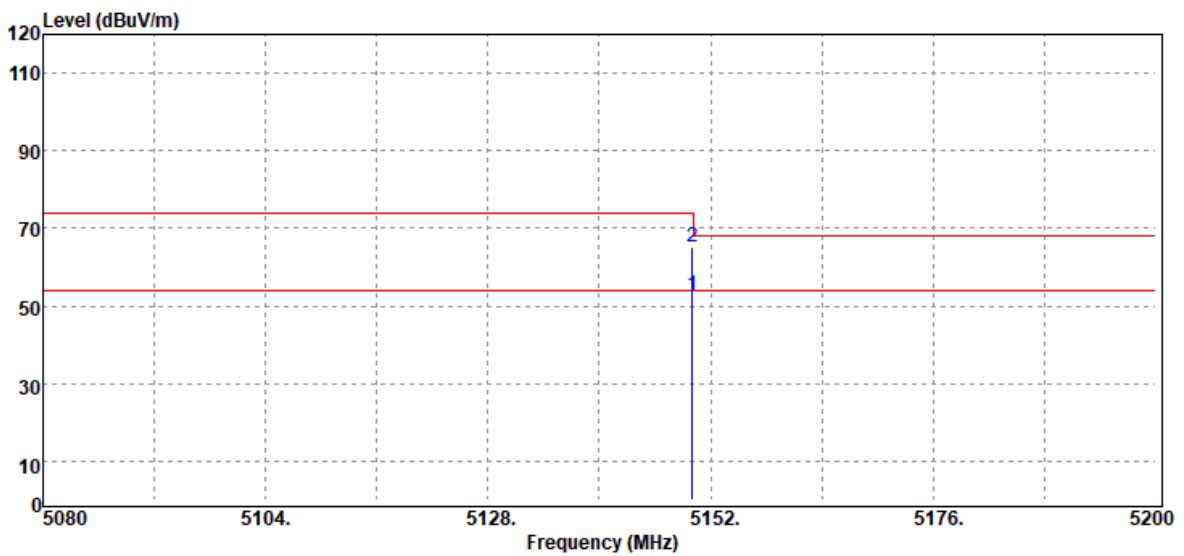

Frequency (MHz)	Detector Mode PK/QP/AV	Spectrum Reading Level dB μ V	Factor dB	Actual FS dB μ V/m	Limit @3m dB μ V/m	Margin dB
5150.00	Average	47.12	5.58	52.70	54.00	-1.30
5150.00	Peak	59.43	5.58	65.01	74.00	-8.99

Report No.: T200504W06-RP4

Test Mode	IEEE 802.11n 40 MHz / 5230MHz	Temp/Hum	23.6(°C)/ 45%RH
Test Item	Band Edge	Test Date	May 14, 2020
Polarize	Vertical	Test Engineer	Jerry Chang
Detector	Peak and Average		

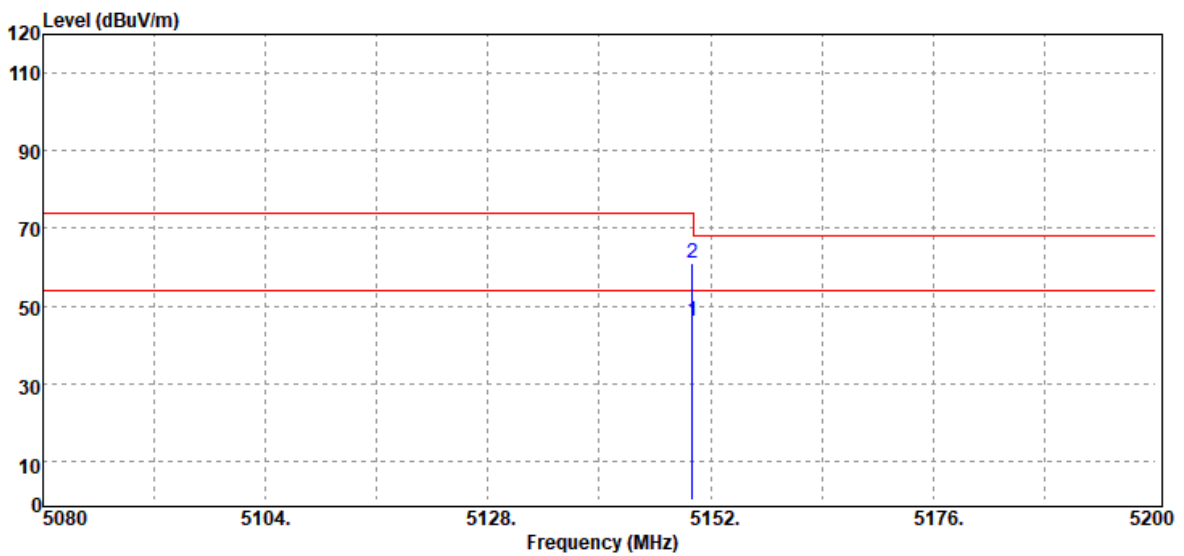

Frequency (MHz)	Detector Mode PK/QP/AV	Spectrum Reading Level dB μ V	Factor dB	Actual FS dB μ V/m	Limit @3m dB μ V/m	Margin dB
5150.00	Average	40.40	5.58	45.98	54.00	-8.02
5150.00	Peak	55.56	5.58	61.14	74.00	-12.86

Report No.: T200504W06-RP4

Test Data for UNII-2a

Test Mode	IEEE 802.11a / 5320 MHz	Temp/Hum	23.6(°C)/ 45%RH
Test Item	Band Edge	Test Date	May 14, 2020
Polarize	Vertical	Test Engineer	Jerry Chang
Detector	Peak and Average		

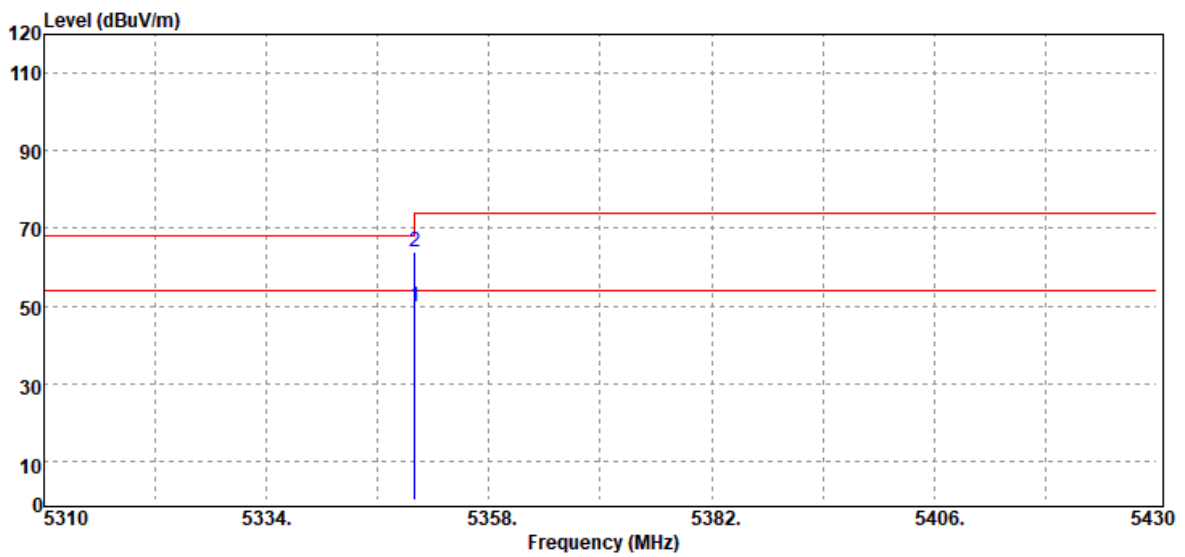

Frequency (MHz)	Detector Mode PK/QP/AV	Spectrum Reading Level dBμV	Factor dB	Actual FS dBμV/m	Limit @3m dBμV/m	Margin dB
5350.00	Average	43.86	5.82	49.68	54.00	-4.32
5350.00	Peak	58.32	5.82	64.14	74.00	-9.86

Report No.: T200504W06-RP4

Test Mode	IEEE 802.11a / 5320 MHz	Temp/Hum	23.6(°C)/ 45%RH
Test Item	Band Edge	Test Date	May 14, 2020
Polarize	Horizontal	Test Engineer	Jerry Chang
Detector	Peak and Average		

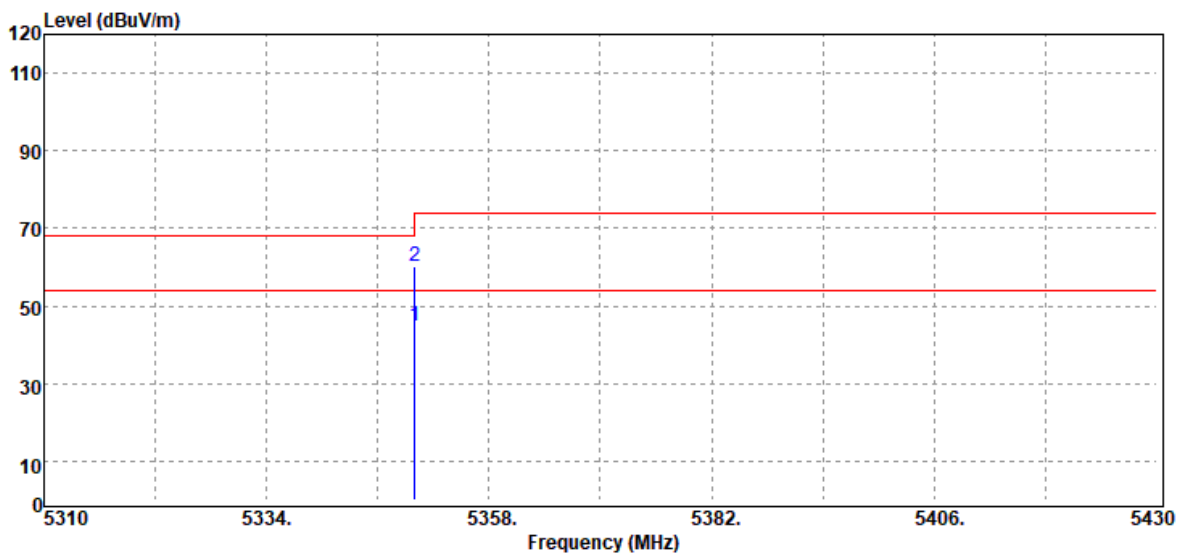

Frequency (MHz)	Detector Mode PK/QP/AV	Spectrum Reading Level dB μ V	Factor dB	Actual FS dB μ V/m	Limit @3m dB μ V/m	Margin dB
5350.00	Average	38.86	5.82	44.68	54.00	-9.32
5350.00	Peak	54.29	5.82	60.11	74.00	-13.89

Report No.: T200504W06-RP4

Test Mode	IEEE 802.11n 20 MHz / 5320MHz	Temp/Hum	23.6(°C)/ 45%RH
Test Item	Band Edge	Test Date	May 14, 2020
Polarize	Vertical	Test Engineer	Jerry Chang
Detector	Peak and Average		

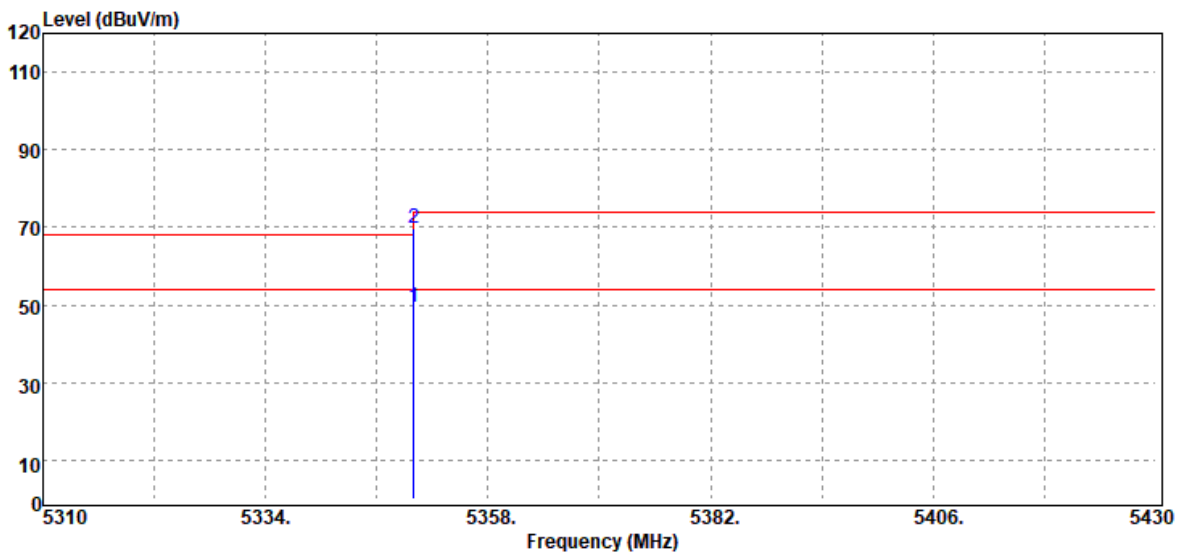

Frequency (MHz)	Detector Mode PK/QP/AV	Spectrum Reading Level dB μ V	Factor dB	Actual FS dB μ V/m	Limit @3m dB μ V/m	Margin dB
5350.00	Average	43.56	5.82	49.38	54.00	-4.62
5350.00	Peak	64.01	5.82	69.83	74.00	-4.17

Report No.: T200504W06-RP4

Test Mode	IEEE 802.11n 20 MHz / 5320MHz	Temp/Hum	23.6(°C)/ 45%RH
Test Item	Band Edge	Test Date	May 14, 2020
Polarize	Horizontal	Test Engineer	Jerry Chang
Detector	Peak and Average		

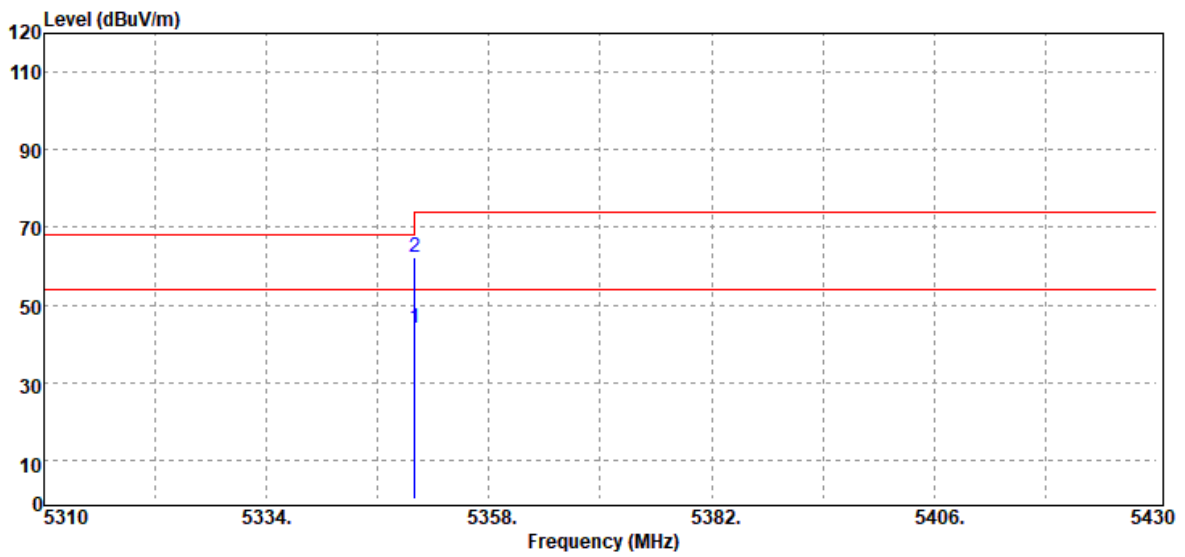

Frequency (MHz)	Detector Mode PK/QP/AV	Spectrum Reading Level dB μ V	Factor dB	Actual FS dB μ V/m	Limit @3m dB μ V/m	Margin dB
5350.00	Average	38.21	5.82	44.03	54.00	-9.97
5350.00	Peak	56.65	5.82	62.47	74.00	-11.53

Report No.: T200504W06-RP4

Test Mode	IEEE 802.11n 40 MHz / 5310MHz	Temp/Hum	23.6(°C)/ 45%RH
Test Item	Band Edge	Test Date	May 14, 2020
Polarize	Vertical	Test Engineer	Jerry Chang
Detector	Peak and Average		

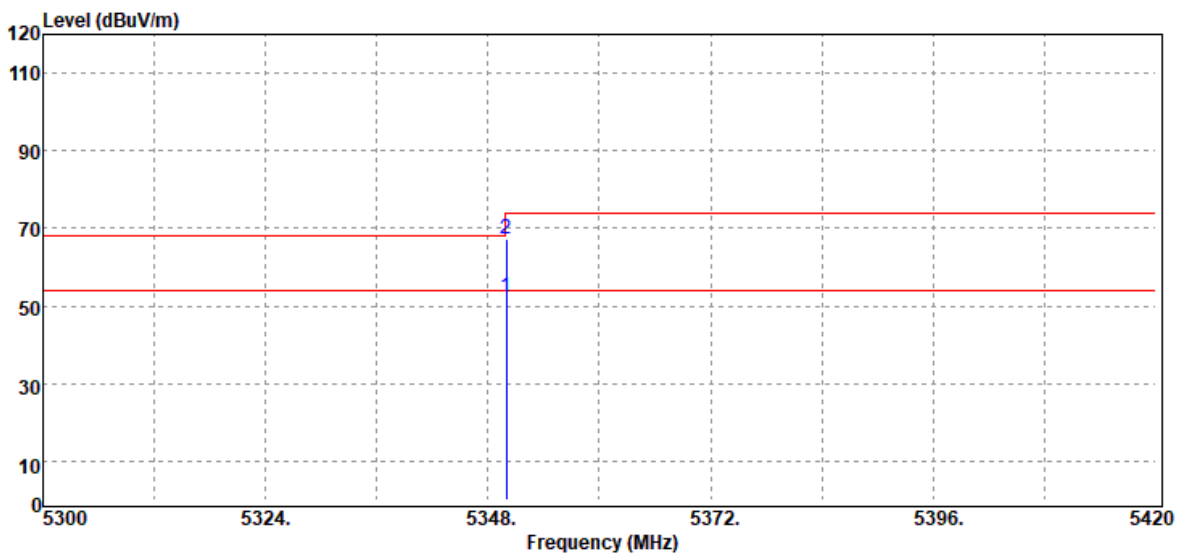

Frequency (MHz)	Detector Mode PK/QP/AV	Spectrum Reading Level dB μ V	Factor dB	Actual FS dB μ V/m	Limit @3m dB μ V/m	Margin dB
5350.00	Average	46.35	5.82	52.17	54.00	-1.83
5350.00	Peak	61.60	5.82	67.42	74.00	-6.58

Report No.: T200504W06-RP4

Test Mode	IEEE 802.11n 40 MHz / 5310MHz	Temp/Hum	23.6(°C)/ 45%RH
Test Item	Band Edge	Test Date	May 14, 2020
Polarize	Horizontal	Test Engineer	Jerry Chang
Detector	Peak and Average		

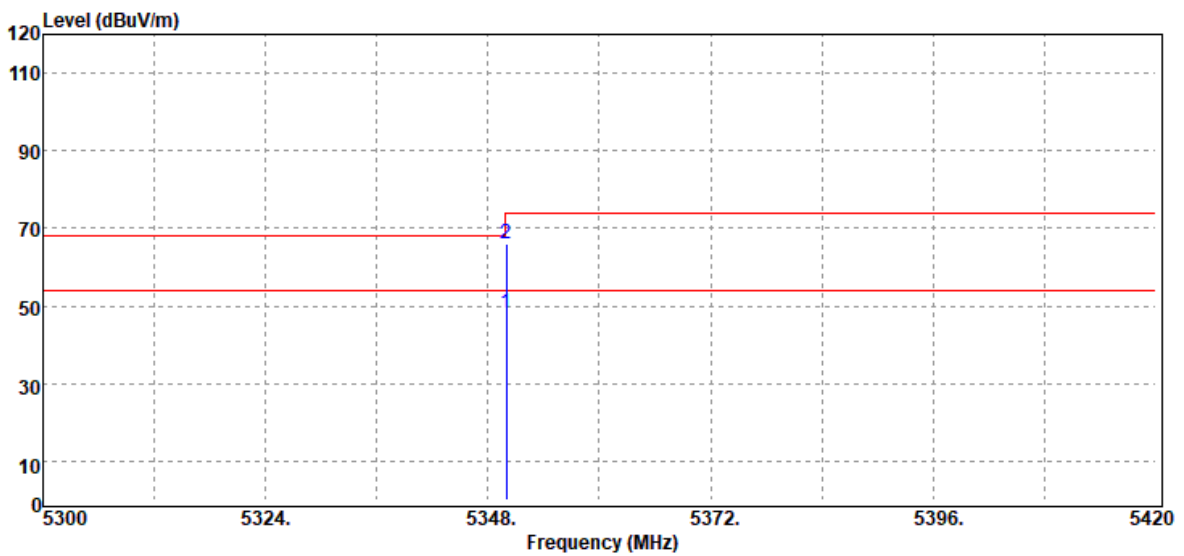

Frequency (MHz)	Detector Mode PK/QP/AV	Spectrum Reading Level dB μ V	Factor dB	Actual FS dB μ V/m	Limit @3m dB μ V/m	Margin dB
5350.00	Average	42.30	5.82	48.12	54.00	-5.88
5350.00	Peak	60.03	5.82	65.85	74.00	-8.15

Report No.: T200504W06-RP4

Test Data for UNII-2c

Test Mode	IEEE 802.11a / 5500MHz	Temp/Hum	23.6(°C)/ 45%RH
Test Item	Band Edge	Test Date	May 14, 2020
Polarize	Vertical	Test Engineer	Jerry Chang
Detector	Peak and Average		

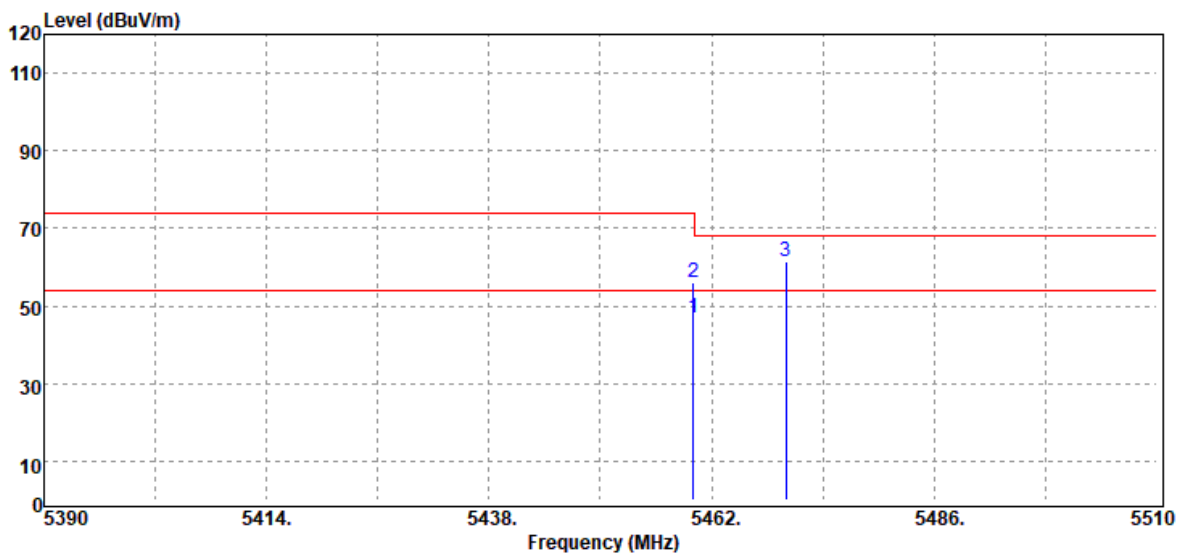

Frequency (MHz)	Detector Mode PK/QP/AV	Spectrum Reading Level dBµV	Factor dB	Actual FS dBµV/m	Limit @3m dBµV/m	Margin dB
5460.00	Average	40.92	6.11	47.03	54.00	-6.97
5460.00	Peak	50.11	6.11	56.22	74.00	-17.78
5470.00	Peak	55.27	6.14	61.41	68.20	-6.79

Report No.: T200504W06-RP4

Test Mode	IEEE 802.11a / 5500MHz	Temp/Hum	23.6(°C)/ 45%RH
Test Item	Band Edge	Test Date	May 14, 2020
Polarize	Horizontal	Test Engineer	Jerry Chang
Detector	Peak and Average		

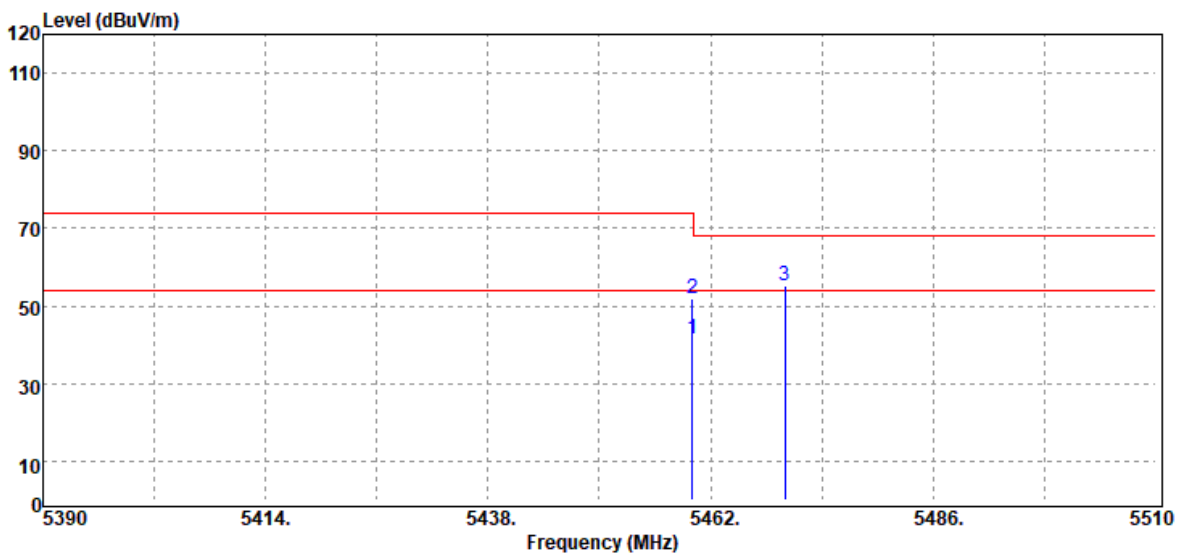

Frequency (MHz)	Detector Mode PK/QP/AV	Spectrum Reading Level dBuV	Factor dB	Actual FS dBuV/m	Limit @3m dBuV/m	Margin dB
5460.00	Average	35.38	6.11	41.49	54.00	-12.51
5460.00	Peak	45.69	6.11	51.80	74.00	-22.20
5470.00	Peak	48.97	6.14	55.11	68.20	-13.09

Report No.: T200504W06-RP4

Test Mode	IEEE 802.11a / 5700 MHz	Temp/Hum	23.6(°C)/ 45%RH
Test Item	Band Edge	Test Date	May 14, 2020
Polarize	Vertical	Test Engineer	Jerry Chang
Detector	Peak		

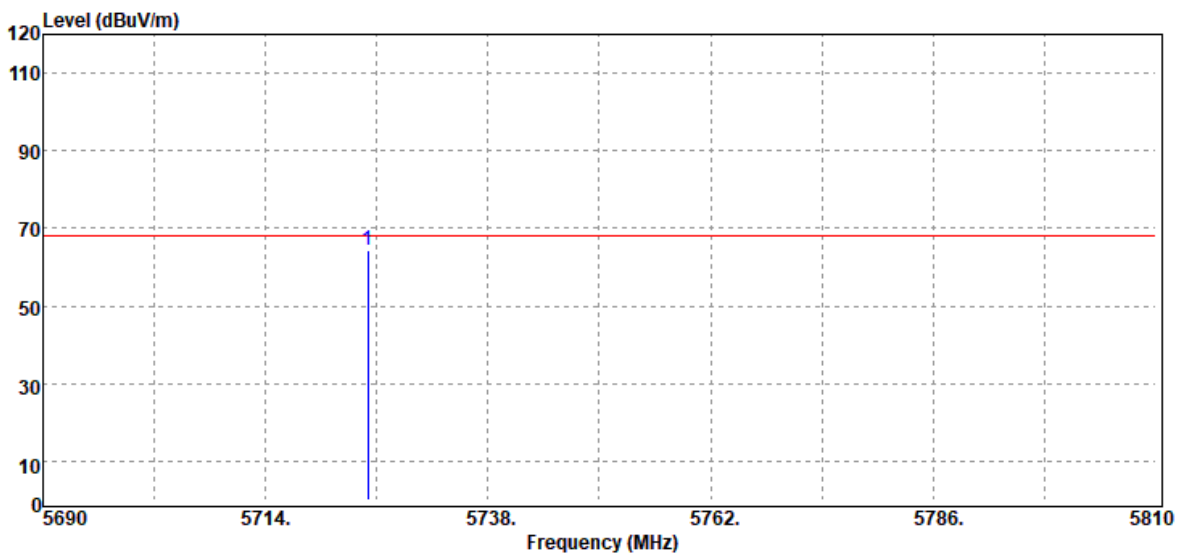

Frequency (MHz)	Detector Mode PK/QP/AV	Spectrum Reading Level dB μ V	Factor dB	Actual FS dB μ V/m	Limit @3m dB μ V/m	Margin dB
5725.00	Peak	57.26	6.98	64.24	68.20	-3.96

Report No.: T200504W06-RP4

Test Mode	IEEE 802.11a / 5700 MHz	Temp/Hum	23.6(°C)/ 45%RH
Test Item	Band Edge	Test Date	May 14, 2020
Polarize	Horizontal	Test Engineer	Jerry Chang
Detector	Peak		

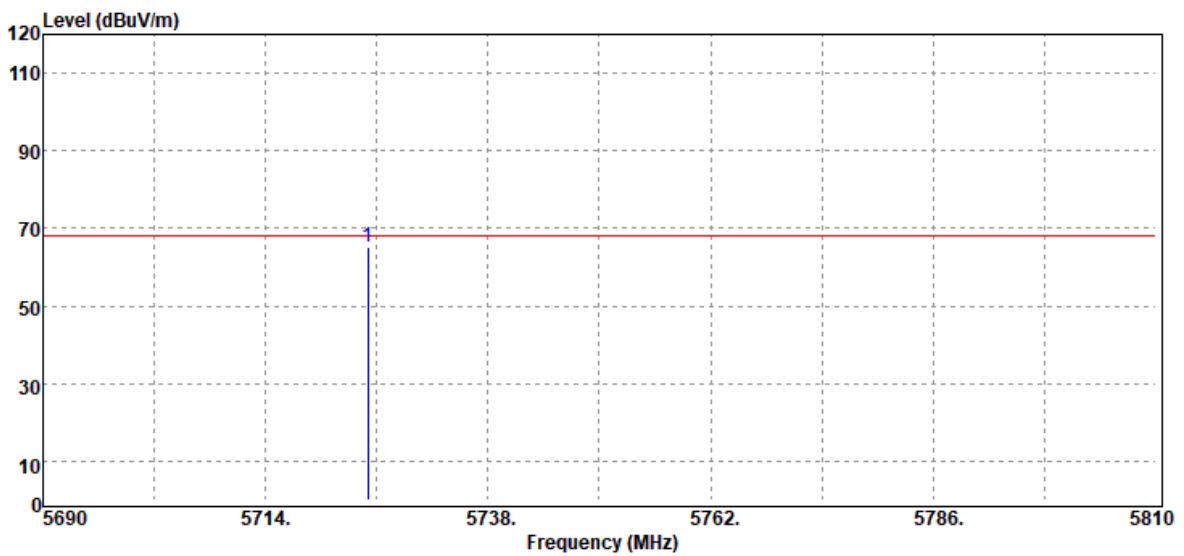

Frequency (MHz)	Detector Mode PK/QP/AV	Spectrum Reading Level dB μ V	Factor dB	Actual FS dB μ V/m	Limit @3m dB μ V/m	Margin dB
5725.00	Peak	58.03	6.98	65.01	68.20	-3.19

Report No.: T200504W06-RP4

Test Mode	IEEE 802.11n 20 MHz / 5500MHz	Temp/Hum	23.6(°C)/ 45%RH
Test Item	Band Edge	Test Date	May 14, 2020
Polarize	Vertical	Test Engineer	Jerry Chang
Detector	Peak and Average		

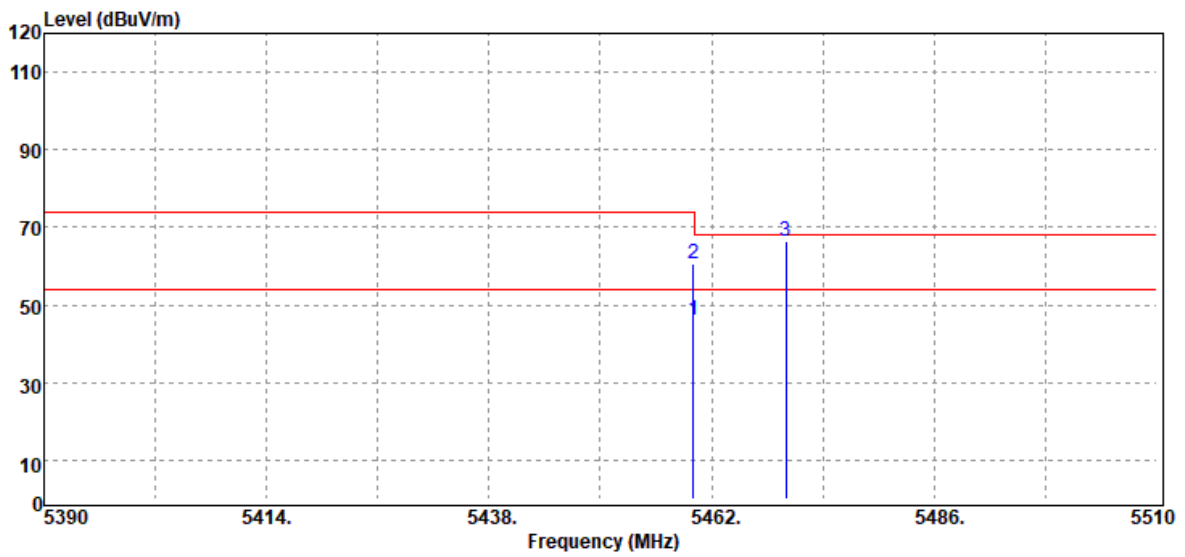

Frequency (MHz)	Detector Mode PK/QP/AV	Spectrum Reading Level dB μ V	Factor dB	Actual FS dB μ V/m	Limit @3m dB μ V/m	Margin dB
5460.00	Average	39.94	6.11	46.05	54.00	-7.95
5460.00	Peak	54.61	6.11	60.72	74.00	-13.28
5470.00	Peak	60.47	6.14	66.61	68.20	-1.59

Report No.: T200504W06-RP4

Test Mode	IEEE 802.11n 20 MHz / 5500MHz	Temp/Hum	23.6(°C)/ 45%RH
Test Item	Band Edge	Test Date	May 14, 2020
Polarize	Horizontal	Test Engineer	Jerry Chang
Detector	Peak and Average		

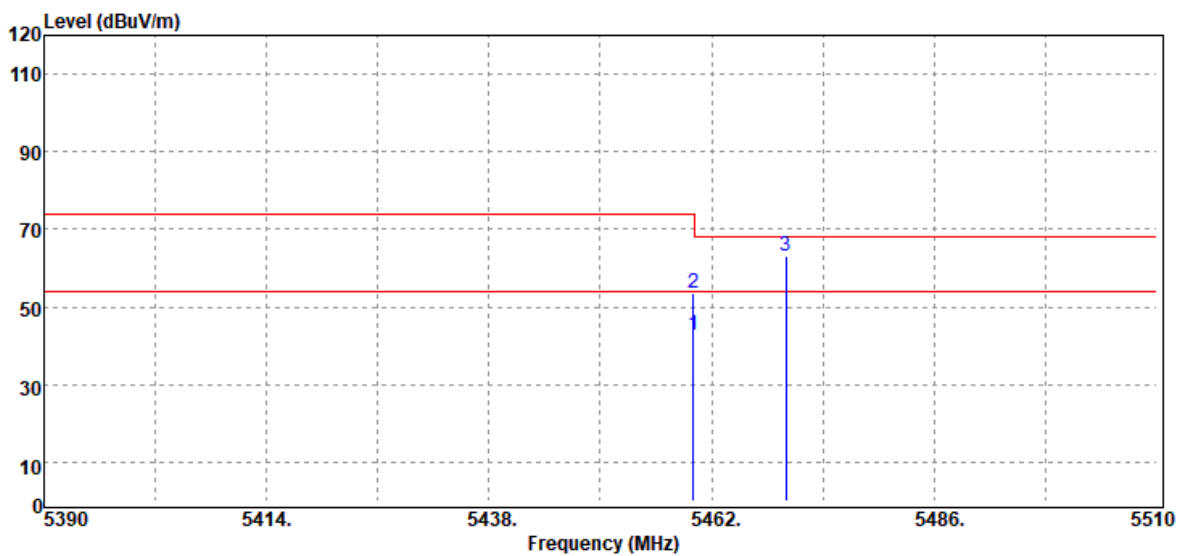

Frequency (MHz)	Detector Mode PK/QP/AV	Spectrum Reading Level dB μ V	Factor dB	Actual FS dB μ V/m	Limit @3m dB μ V/m	Margin dB
5460.00	Average	36.57	6.11	42.68	54.00	-11.32
5460.00	Peak	47.45	6.11	53.56	74.00	-20.44
5470.00	Peak	57.10	6.14	63.24	68.20	-4.96

Report No.: T200504W06-RP4

Test Mode	IEEE 802.11n 20 MHz / 5700 MHz	Temperature	23.6(°C)/ 45%RH
Test Item	Band Edge	Test Date	May 14, 2020
Polarize	Vertical	Test Engineer	Jerry Chang
Detector	Peak		

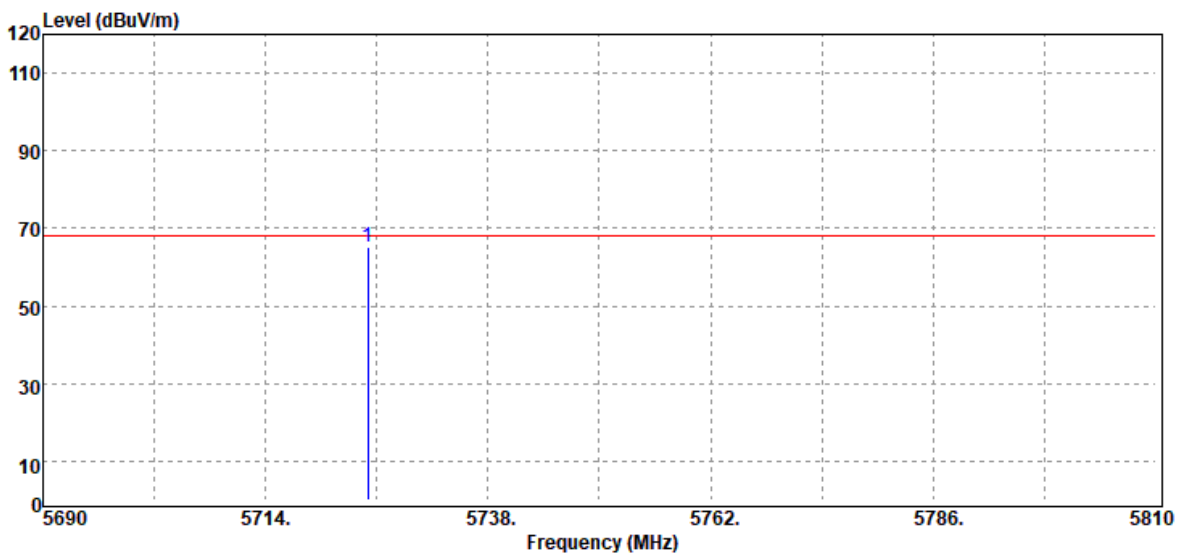

Frequency (MHz)	Detector Mode PK/QP/AV	Spectrum Reading Level dB μ V	Factor dB	Actual FS dB μ V/m	Limit @3m dB μ V/m	Margin dB
5725.00	Peak	58.35	6.98	65.33	68.20	-2.87

Report No.: T200504W06-RP4

Test Mode	IEEE 802.11n 20 MHz / 5700 MHz	Temperature	23.6(°C)/ 45%RH
Test Item	Band Edge	Test Date	May 14, 2020
Polarize	Horizontal	Test Engineer	Jerry Chang
Detector	Peak		

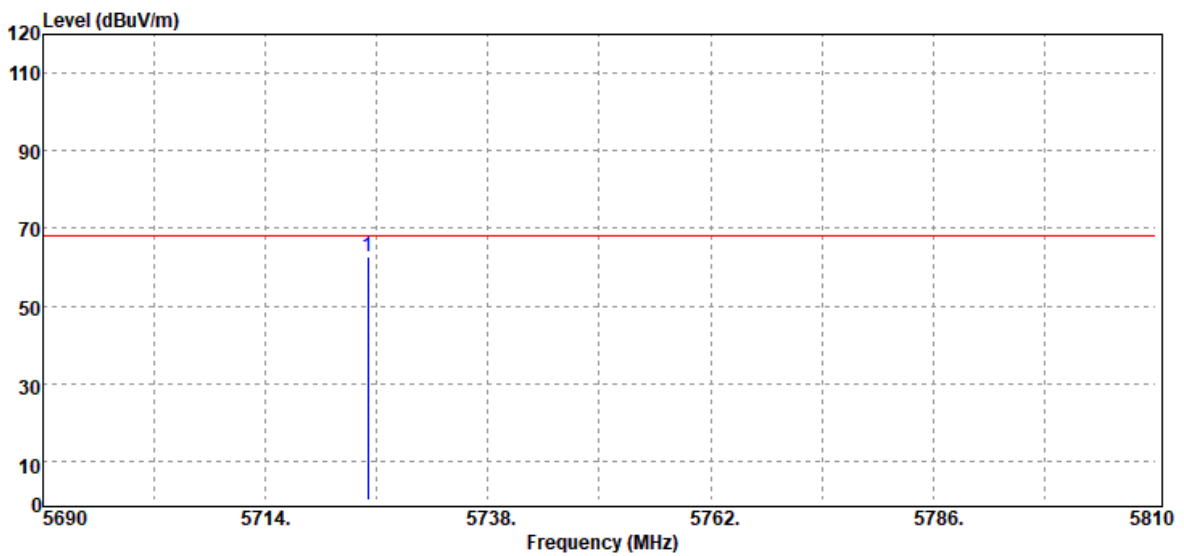

Frequency (MHz)	Detector Mode PK/QP/AV	Spectrum Reading Level dB μ V	Factor dB	Actual FS dB μ V/m	Limit @3m dB μ V/m	Margin dB
5725.00	Peak	55.52	6.98	62.50	68.20	-5.70

Report No.: T200504W06-RP4

Test Mode	IEEE 802.11n 40 MHz / 5510 MHz	Temp/Hum	23.6(°C)/ 45%RH
Test Item	Band Edge	Test Date	May 14, 2020
Polarize	Vertical	Test Engineer	Jerry Chang
Detector	Peak and Average		

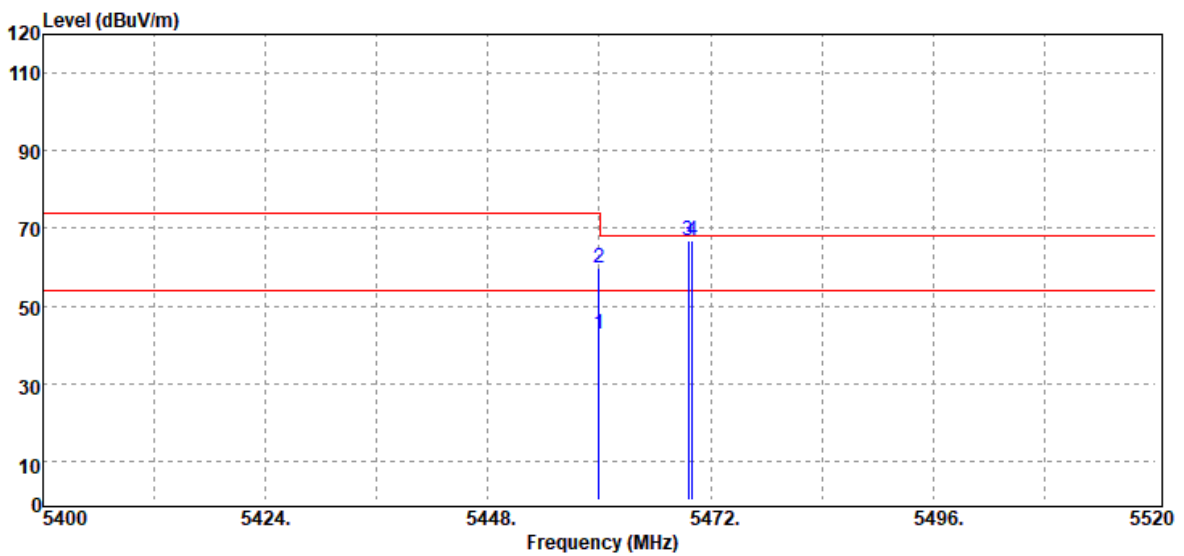

Frequency (MHz)	Detector Mode PK/QP/AV	Spectrum Reading Level dB μ V	Factor dB	Actual FS dB μ V/m	Limit @3m dB μ V/m	Margin dB
5460.00	Average	36.64	6.11	42.75	54.00	-11.25
5460.00	Peak	53.84	6.11	59.95	74.00	-14.05
5469.60	Peak	60.88	6.14	67.02	68.20	-1.18
5470.00	Peak	60.66	6.14	66.80	68.20	-1.40

Report No.: T200504W06-RP4

Test Mode	IEEE 802.11n 40 MHz / 5510 MHz	Temp/Hum	23.6(°C)/ 45%RH
Test Item	Band Edge	Test Date	May 14, 2020
Polarize	Horizontal	Test Engineer	Jerry Chang
Detector	Peak and Average		

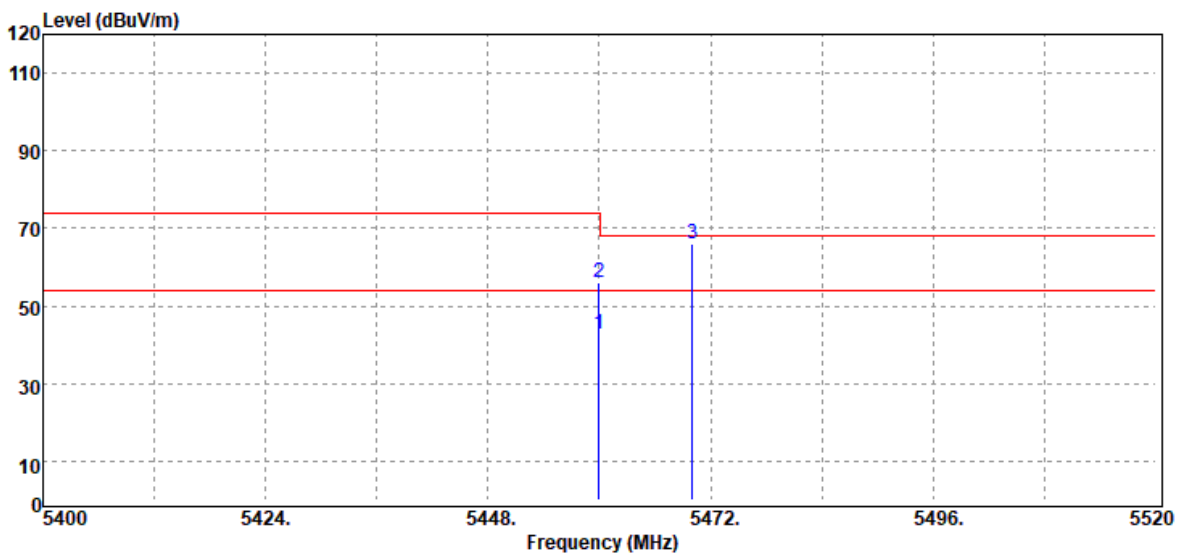

Frequency (MHz)	Detector Mode PK/QP/AV	Spectrum Reading Level dB μ V	Factor dB	Actual FS dB μ V/m	Limit @3m dB μ V/m	Margin dB
5460.00	Average	36.66	6.11	42.77	54.00	-11.23
5460.00	Peak	49.98	6.11	56.09	74.00	-17.91
5470.00	Peak	59.82	6.14	65.96	68.20	-2.24

Report No.: T200504W06-RP4

Test Mode	IEEE 802.11n 40 MHz / 5670 MHz	Temp/Hum	23.6(°C)/ 45%RH
Test Item	Band Edge	Test Date	May 14, 2020
Polarize	Vertical	Test Engineer	Jerry Chang
Detector	Peak		

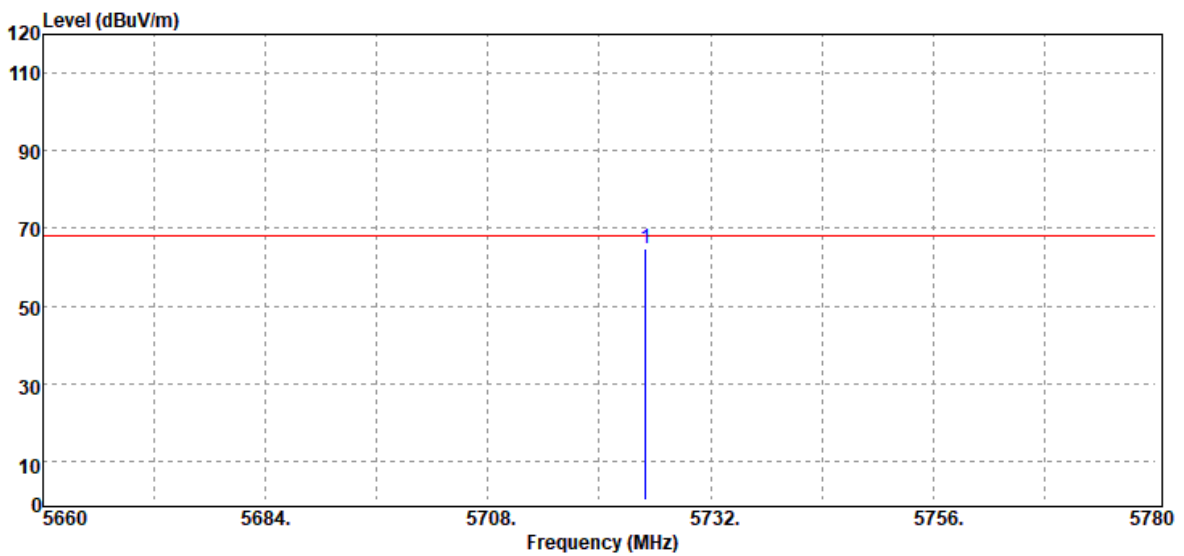

Frequency (MHz)	Detector Mode PK/QP/AV	Spectrum Reading Level dB μ V	Factor dB	Actual FS dB μ V/m	Limit @3m dB μ V/m	Margin dB
5725.00	Peak	57.89	6.98	64.87	68.20	-3.33

Report No.: T200504W06-RP4

Test Mode	IEEE 802.11n 40 MHz / 5670 MHz	Temp/Hum	23.6(°C)/ 45%RH
Test Item	Band Edge	Test Date	May 14, 2020
Polarize	Horizontal	Test Engineer	Jerry Chang
Detector	Peak		

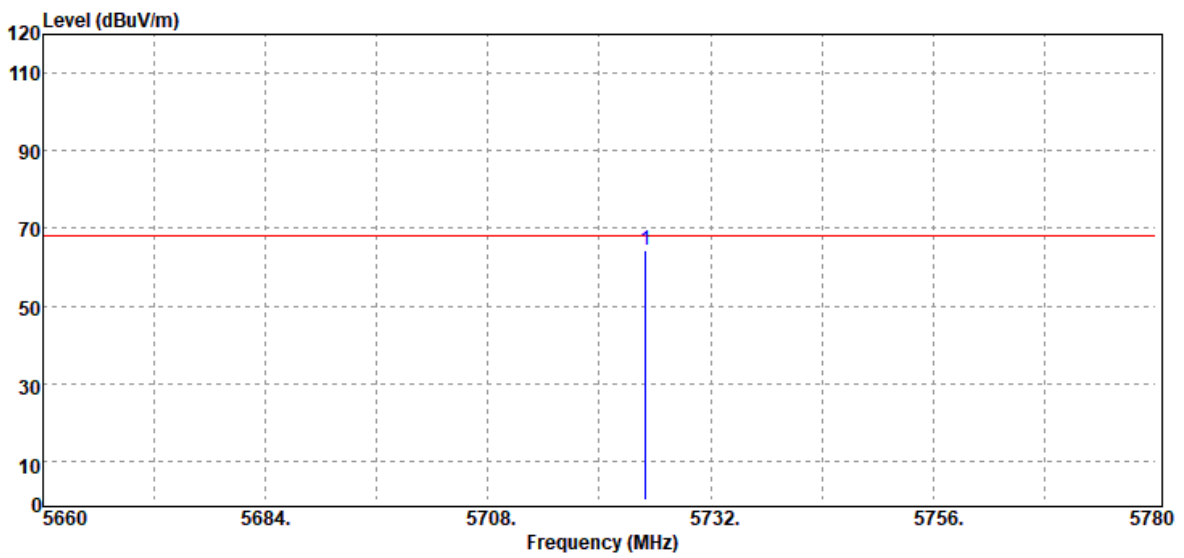

Frequency (MHz)	Detector Mode PK/QP/AV	Spectrum Reading Level dB μ V	Factor dB	Actual FS dB μ V/m	Limit @3m dB μ V/m	Margin dB
5725.00	Peak	57.34	6.98	64.32	68.20	-3.88

Report No.: T200504W06-RP4

Test Data for UNII-3

Test Mode	IEEE 802.11a / 5745 MHz	Temp/Hum	23.6(°C)/ 45%RH
Test Item	Band Edge	Test Date	May 13, 2020
Polarize	Vertical	Test Engineer	Jerry Chang
Detector	Peak		

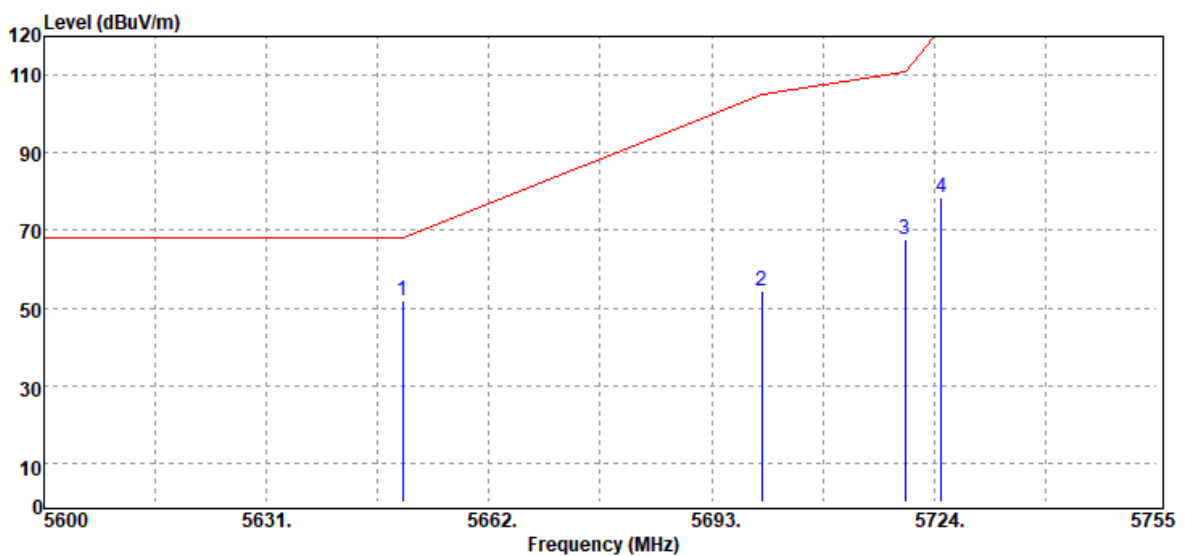

Frequency (MHz)	Detector Mode PK/QP/AV	Spectrum Reading Level dB μ V	Factor dB	Actual FS dB μ V/m	Limit @3m dB μ V/m	Margin dB
5650.00	Peak	45.48	6.61	52.09	68.20	-16.11
5700.00	Peak	47.58	6.92	54.50	105.20	-50.70
5720.00	Peak	60.90	6.97	67.87	110.80	-42.93
5725.00	Peak	71.37	6.98	78.35	122.20	-43.85

Report No.: T200504W06-RP4

Test Mode	IEEE 802.11a / 5745 MHz	Temp/Hum	23.6(°C)/ 45%RH
Test Item	Band Edge	Test Date	May 13, 2020
Polarize	Horizontal	Test Engineer	Jerry Chang
Detector	Peak		

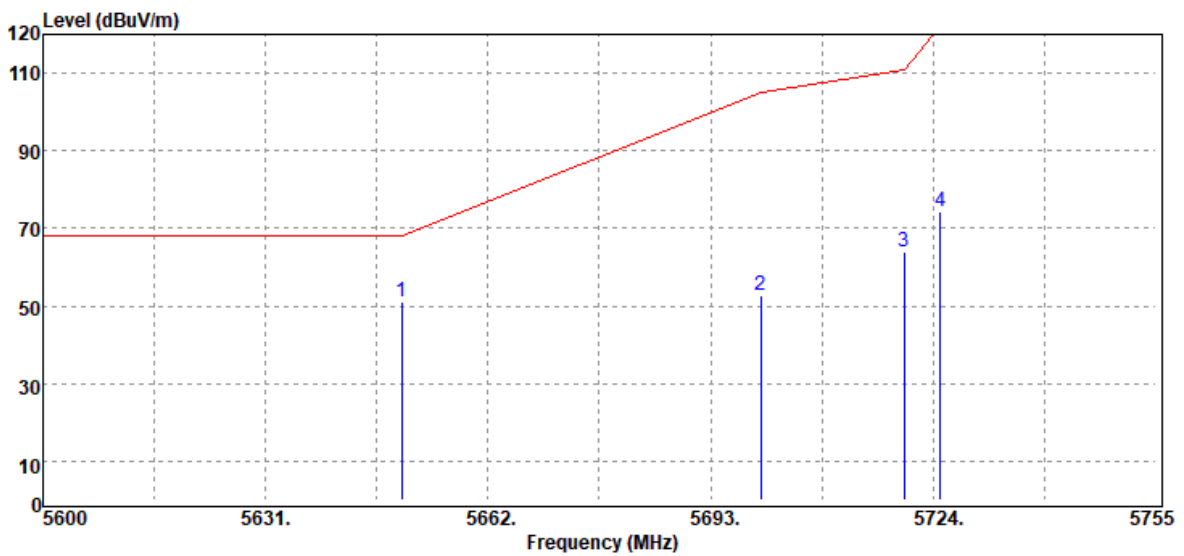

Frequency (MHz)	Detector Mode PK/QP/AV	Spectrum Reading Level dB μ V	Factor dB	Actual FS dB μ V/m	Limit @3m dB μ V/m	Margin dB
5650.00	Peak	44.27	6.61	50.88	68.20	-17.32
5700.00	Peak	45.80	6.92	52.72	105.20	-52.48
5720.00	Peak	56.79	6.97	63.76	110.80	-47.04
5725.00	Peak	67.17	6.98	74.15	122.20	-48.05

Report No.: T200504W06-RP4

Test Mode	IEEE 802.11a / 5825 MHz	Temp/Hum	23.6(°C)/ 45%RH
Test Item	Band Edge	Test Date	May 13, 2020
Polarize	Vertical	Test Engineer	Jerry Chang
Detector	Peak		

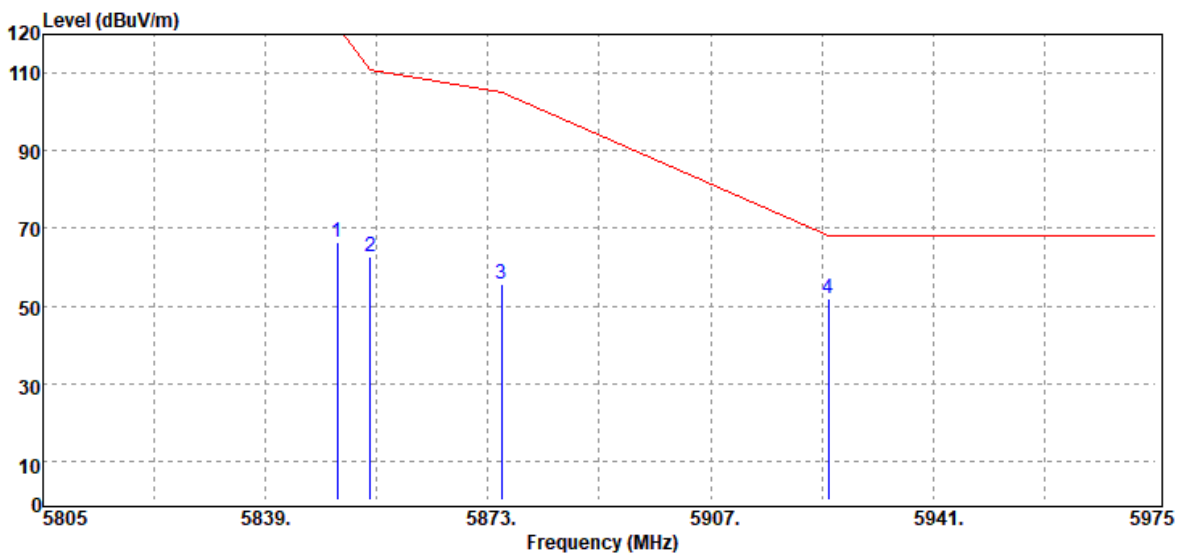

Frequency (MHz)	Detector Mode PK/QP/AV	Spectrum Reading Level dB μ V	Factor dB	Actual FS dB μ V/m	Limit @3m dB μ V/m	Margin dB
5850.00	Peak	59.53	7.11	66.64	122.20	-55.56
5855.00	Peak	55.40	7.11	62.51	110.80	-48.29
5875.00	Peak	48.70	7.10	55.80	105.20	-49.40
5925.00	Peak	44.70	7.12	51.82	68.20	-16.38

Report No.: T200504W06-RP4

Test Mode	IEEE 802.11a / 5825 MHz	Temp/Hum	23.6(°C)/ 45%RH
Test Item	Band Edge	Test Date	May 13, 2020
Polarize	Horizontal	Test Engineer	Jerry Chang
Detector	Peak		

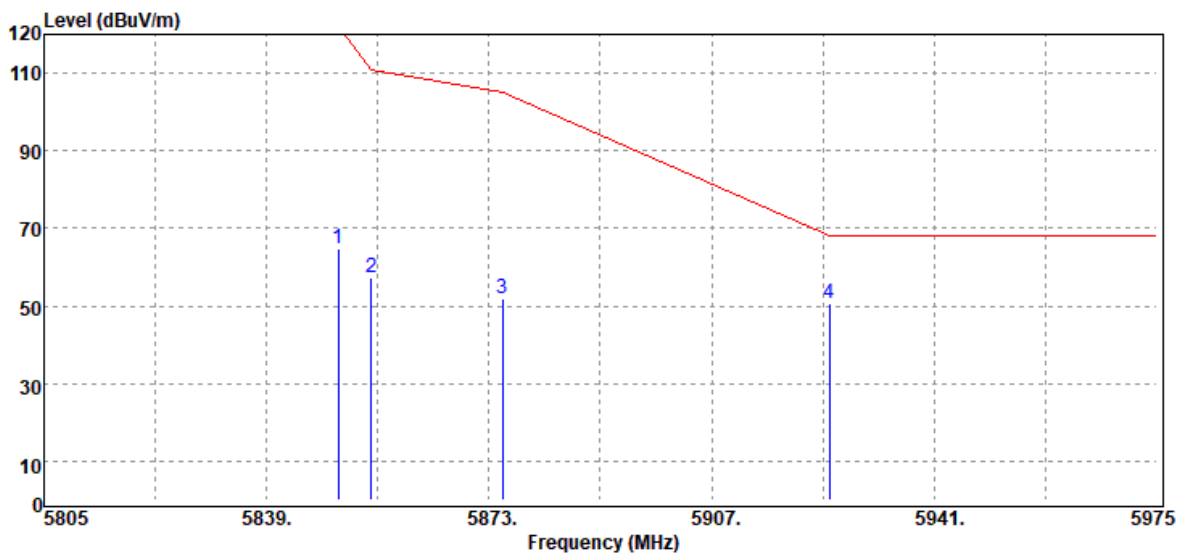

Frequency (MHz)	Detector Mode PK/QP/AV	Spectrum Reading Level dBuV	Factor dB	Actual FS dBuV/m	Limit @3m dBuV/m	Margin dB
5850.00	Peak	57.57	7.11	64.68	122.20	-57.52
5855.00	Peak	50.34	7.11	57.45	110.80	-53.35
5875.00	Peak	44.87	7.10	51.97	105.20	-53.23
5925.00	Peak	43.64	7.12	50.76	68.20	-17.44

Report No.: T200504W06-RP4

Test Mode	IEEE 802.11n 20 MHz / 5745 MHz	Temp/Hum	23.6(°C)/ 45%RH
Test Item	Band Edge	Test Date	May 14, 2020
Polarize	Vertical	Test Engineer	Jerry Chang
Detector	Peak		

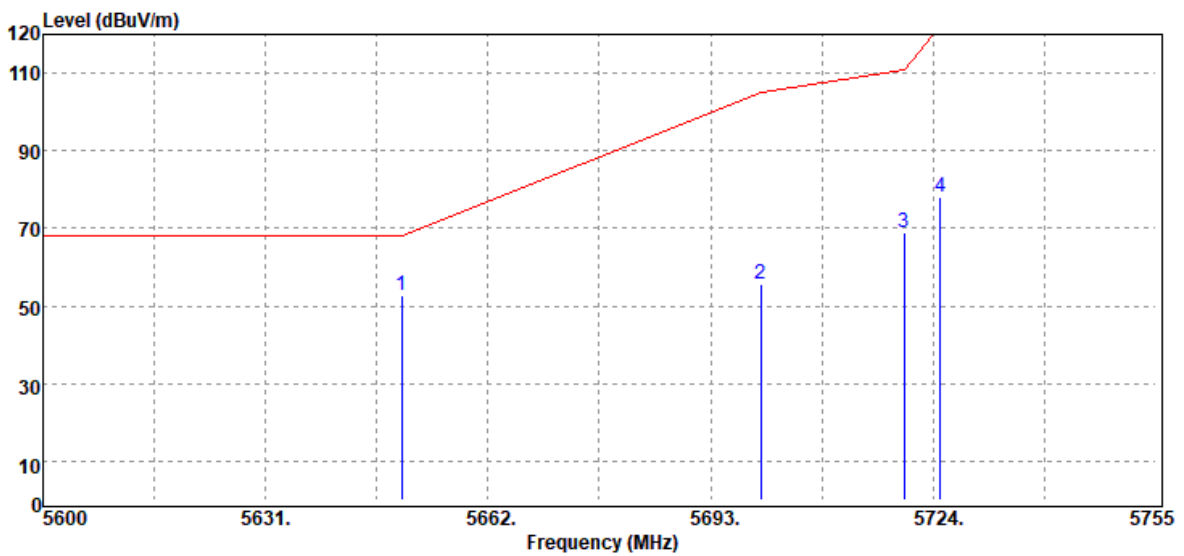

Frequency (MHz)	Detector Mode PK/QP/AV	Spectrum Reading Level dB μ V	Factor dB	Actual FS dB μ V/m	Limit @3m dB μ V/m	Margin dB
5650.00	Peak	46.15	6.61	52.76	68.20	-15.44
5700.00	Peak	48.88	6.92	55.80	105.20	-49.40
5720.00	Peak	62.07	6.97	69.04	110.80	-41.76
5725.00	Peak	70.98	6.98	77.96	122.20	-44.24

Report No.: T200504W06-RP4

Test Mode	IEEE 802.11n 20 MHz / 5745 MHz	Temp/Hum	23.6(°C)/ 45%RH
Test Item	Band Edge	Test Date	May 14, 2020
Polarize	Horizontal	Test Engineer	Jerry Chang
Detector	Peak		

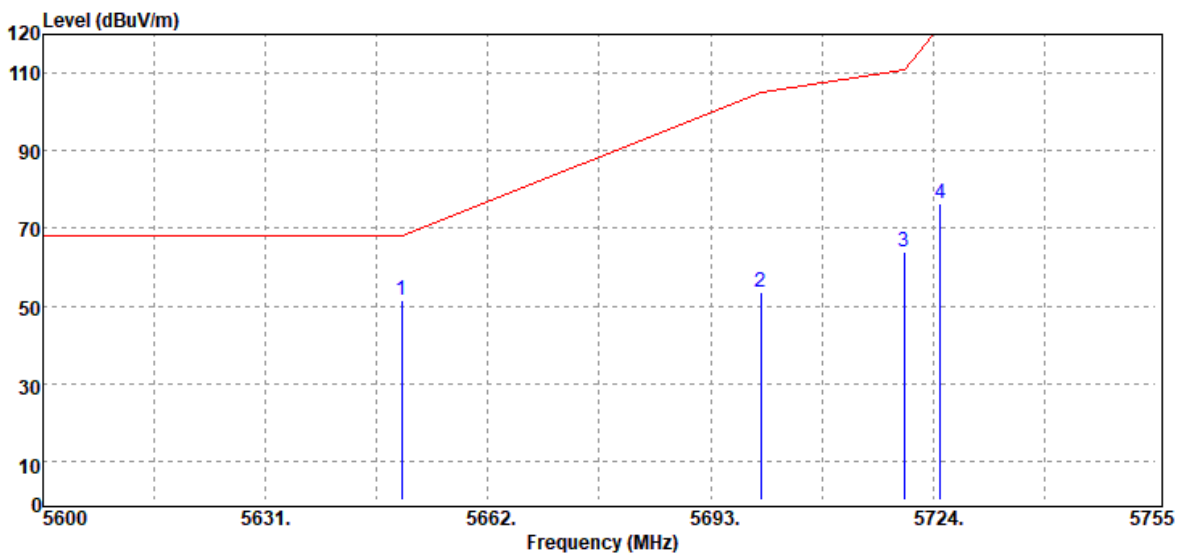

Frequency (MHz)	Detector Mode PK/QP/AV	Spectrum Reading Level dB μ V	Factor dB	Actual FS dB μ V/m	Limit @3m dB μ V/m	Margin dB
5650.00	Peak	44.75	6.61	51.36	68.20	-16.84
5700.00	Peak	46.48	6.92	53.40	105.20	-51.80
5720.00	Peak	57.07	6.97	64.04	110.80	-46.76
5725.00	Peak	69.47	6.98	76.45	122.20	-45.75

Report No.: T200504W06-RP4

Test Mode	IEEE 802.11n 20 MHz / 5825 MHz	Temp/Hum	23.6(°C)/ 45%RH
Test Item	Band Edge	Test Date	May 14, 2020
Polarize	Vertical	Test Engineer	Jerry Chang
Detector	Peak		

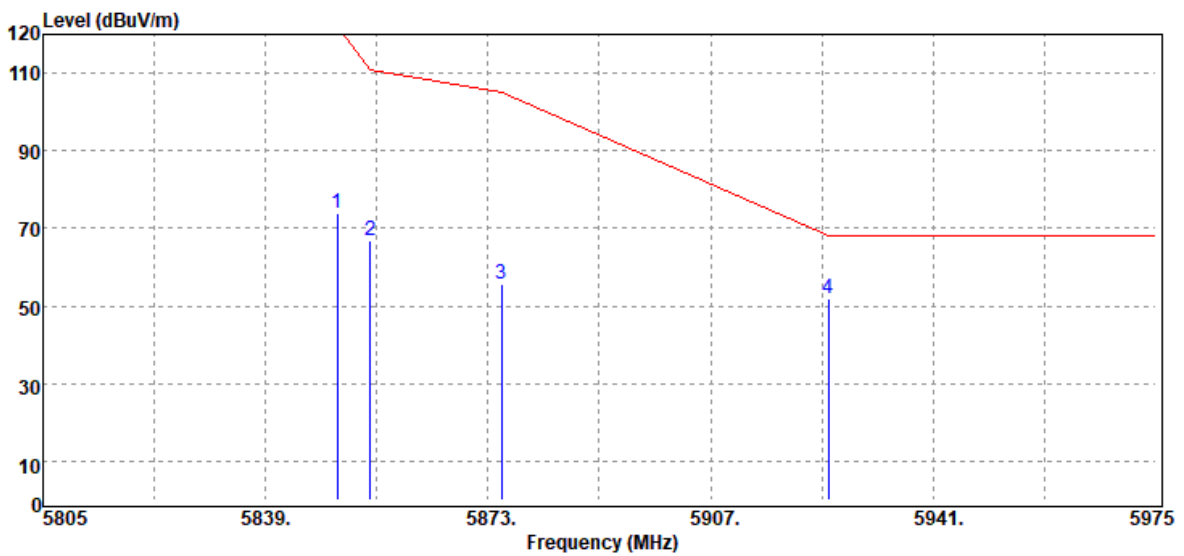

Frequency (MHz)	Detector Mode PK/QP/AV	Spectrum Reading Level dB μ V	Factor dB	Actual FS dB μ V/m	Limit @3m dB μ V/m	Margin dB
5850.00	Peak	67.00	7.11	74.11	122.20	-48.09
5855.00	Peak	59.79	7.11	66.90	110.80	-43.90
5875.00	Peak	48.52	7.10	55.62	105.20	-49.58
5925.00	Peak	44.59	7.12	51.71	68.20	-16.49

Report No.: T200504W06-RP4

Test Mode	IEEE 802.11n 20 MHz / 5825 MHz	Temp/Hum	23.6(°C)/ 45%RH
Test Item	Band Edge	Test Date	May 14, 2020
Polarize	Horizontal	Test Engineer	Jerry Chang
Detector	Peak		

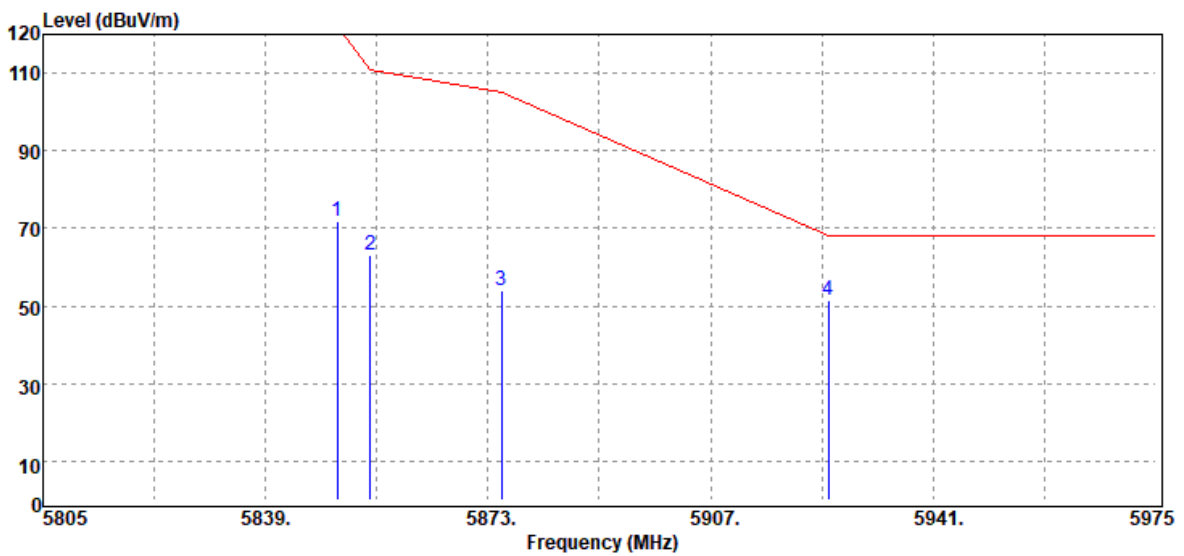

Frequency (MHz)	Detector Mode PK/QP/AV	Spectrum Reading Level dB μ V	Factor dB	Actual FS dB μ V/m	Limit @3m dB μ V/m	Margin dB
5850.00	Peak	64.59	7.11	71.70	122.20	-50.50
5855.00	Peak	55.81	7.11	62.92	110.80	-47.88
5875.00	Peak	47.08	7.10	54.18	105.20	-51.02
5925.00	Peak	44.45	7.12	51.57	68.20	-16.63

Report No.: T200504W06-RP4

Test Mode	IEEE 802.11n 40 MHz/ 5755 MHz	Temp/Hum	23.6(°C)/ 45%RH
Test Item	Band Edge	Test Date	May 14, 2020
Polarize	Vertical	Test Engineer	Jerry Chang
Detector	Peak		

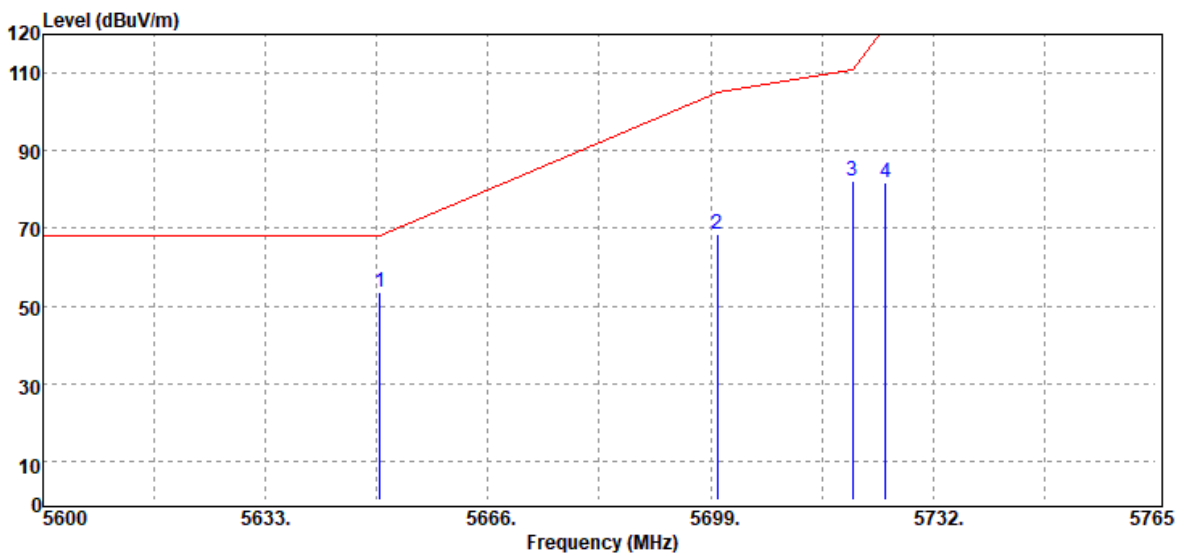

Frequency (MHz)	Detector Mode PK/QP/AV	Spectrum Reading Level dB μ V	Factor dB	Actual FS dB μ V/m	Limit @3m dB μ V/m	Margin dB
5650.00	Peak	46.94	6.61	53.55	68.20	-14.65
5700.00	Peak	61.65	6.92	68.57	105.20	-36.63
5720.00	Peak	75.36	6.97	82.33	110.80	-28.47
5725.00	Peak	74.79	6.98	81.77	122.20	-40.43

Report No.: T200504W06-RP4

Test Mode	IEEE 802.11n 40 MHz/ 5755 MHz	Temp/Hum	23.6(°C)/ 45%RH
Test Item	Band Edge	Test Date	May 14, 2020
Polarize	Horizontal	Test Engineer	Jerry Chang
Detector	Peak		

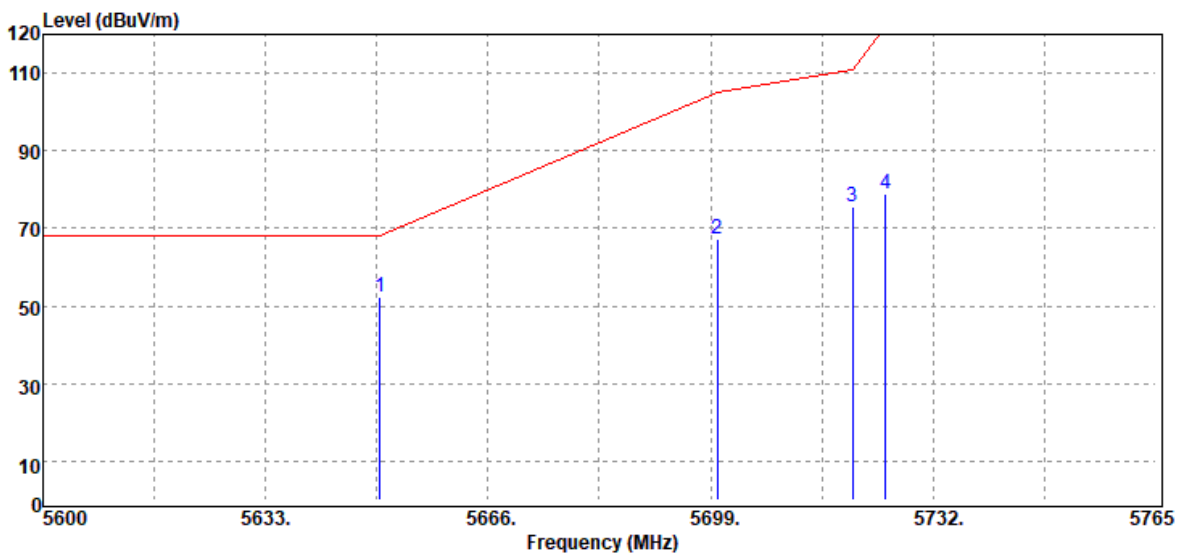

Frequency (MHz)	Detector Mode PK/QP/AV	Spectrum Reading Level dBμV	Factor dB	Actual FS dBμV/m	Limit @3m dBμV/m	Margin dB
5650.00	Peak	45.82	6.61	52.43	68.20	-15.77
5700.00	Peak	60.31	6.92	67.23	105.20	-37.97
5720.00	Peak	68.66	6.97	75.63	110.80	-35.17
5725.00	Peak	71.78	6.98	78.76	122.20	-43.44

Report No.: T200504W06-RP4

Test Mode	IEEE 802.11n 40 MHz/ 5795 MHz	Temp/Hum	23.6(°C)/ 45%RH
Test Item	Band Edge	Test Date	May 14, 2020
Polarize	Vertical	Test Engineer	Jerry Chang
Detector	Peak		

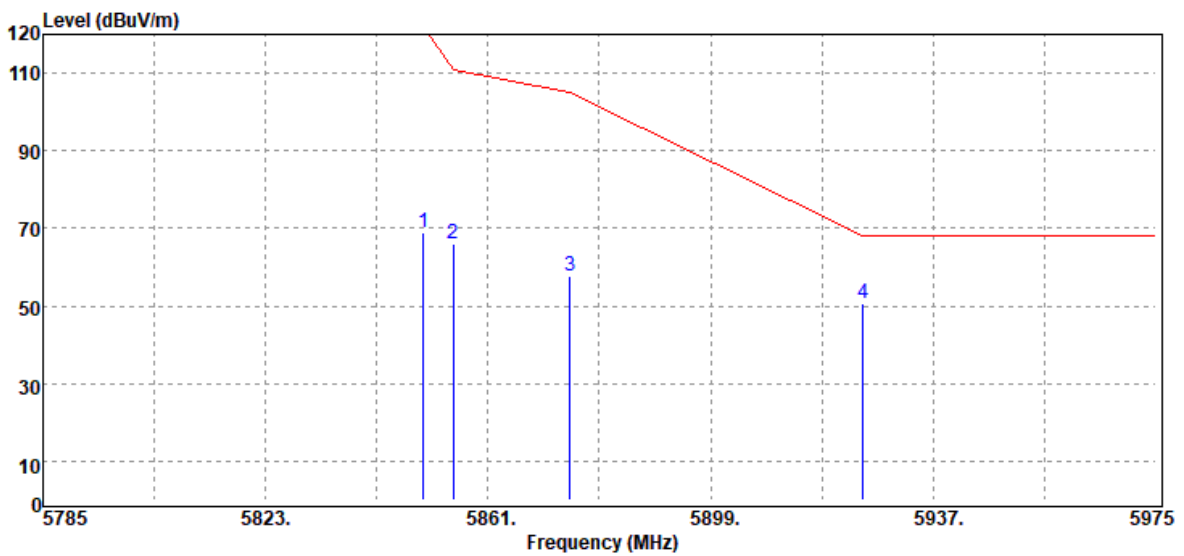

Frequency (MHz)	Detector Mode PK/QP/AV	Spectrum Reading Level dB μ V	Factor dB	Actual FS dB μ V/m	Limit @3m dB μ V/m	Margin dB
5850.00	Peak	61.91	7.11	69.02	122.20	-53.18
5855.00	Peak	58.97	7.11	66.08	110.80	-44.72
5875.00	Peak	50.67	7.10	57.77	105.20	-47.43
5925.00	Peak	43.71	7.12	50.83	68.20	-17.37

Report No.: T200504W06-RP4

Test Mode	IEEE 802.11n 40 MHz/ 5795 MHz	Temp/Hum	23.6(°C)/ 45%RH
Test Item	Band Edge	Test Date	May 14, 2020
Polarize	Horizontal	Test Engineer	Jerry Chang
Detector	Peak		

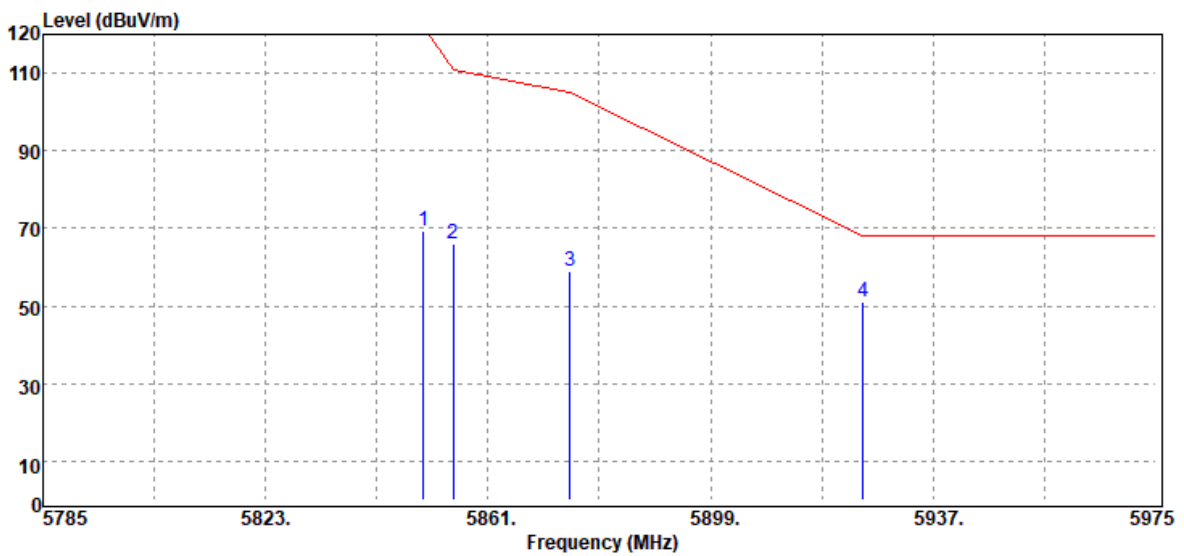

Frequency (MHz)	Detector Mode PK/QP/AV	Spectrum Reading Level dB μ V	Factor dB	Actual FS dB μ V/m	Limit @3m dB μ V/m	Margin dB
5850.00	Peak	62.27	7.11	69.38	122.20	-52.82
5855.00	Peak	58.85	7.11	65.96	110.80	-44.84
5875.00	Peak	51.84	7.10	58.94	105.20	-46.26
5925.00	Peak	43.87	7.12	50.99	68.20	-17.21

Report No.: T200504W06-RP4

Below 1G Test Data

Test Mode	Mode 1	Temp/Hum	23.6(°C)/ 45%RH
Test Item	30MHz-1GHz	Test Date	May 13, 2020
Polarize	Vertical	Test Engineer	Jerry Chang
Detector	Peak		

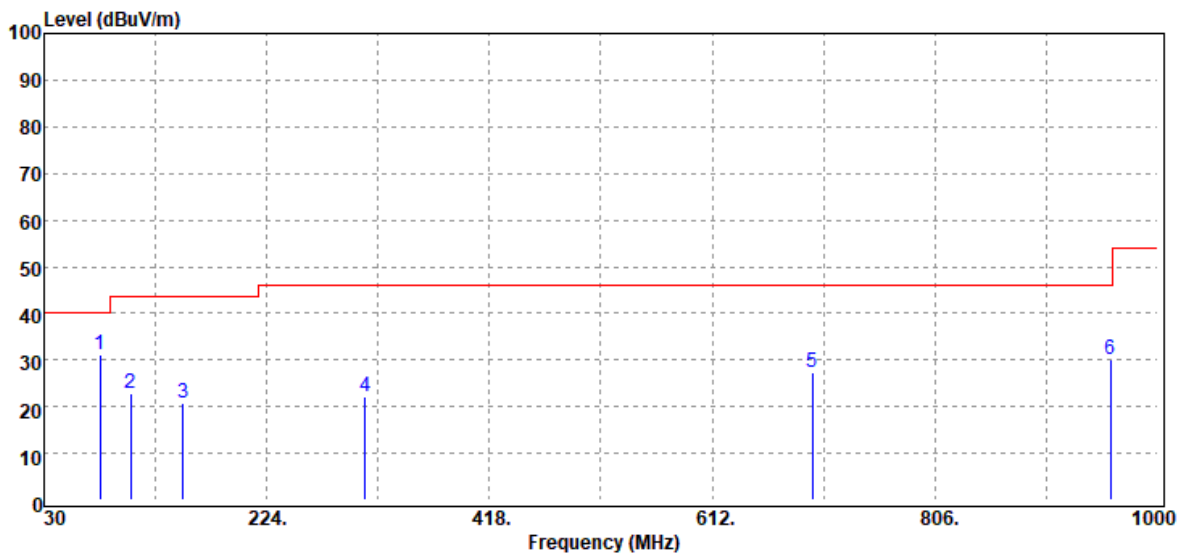

Freq. MHz	Detector Mode PK/QP/AV	Spectrum Reading Level dBμV	Factor dB	Actual FS dBμV/m	Limit @3m dBμV/m	Margin dB
78.50	Peak	46.46	-15.33	31.13	40.00	-8.87
105.66	Peak	34.15	-11.23	22.92	43.50	-20.58
151.25	Peak	30.89	-10.27	20.62	43.50	-22.88
309.36	Peak	30.28	-8.18	22.10	46.00	-23.90
699.30	Peak	27.30	0.15	27.45	46.00	-18.55
959.26	Peak	25.96	4.14	30.10	46.00	-15.90

Note: 1. No emission found between lowest internal used/generated frequency to 30MHz(9KHz~30MHz)
 2. For below 1GHz, the EUT peak value was under average limit, therefore the Average value compliance with the average limit.

Report No.: T200504W06-RP4

Test Mode	Mode 1	Temp/Hum	23.6(°C)/ 45%RH
Test Item	30MHz-1GHz	Test Date	May 13, 2020
Polarize	Horizontal	Test Engineer	Jerry Chang
Detector	Peak		

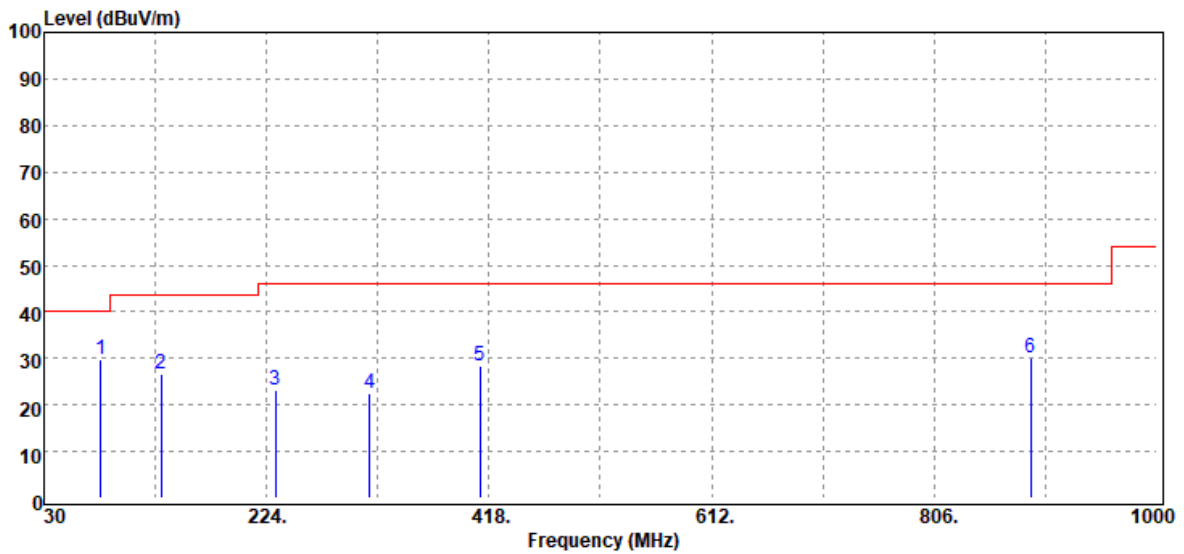

Freq. MHz	Detector Mode PK/QP/AV	Spectrum Reading Level dBμV	Factor dB	Actual FS dBμV/m	Limit @3m dBμV/m	Margin dB
79.47	Peak	45.10	-15.38	29.72	40.00	-10.28
131.85	Peak	35.75	-9.25	26.50	43.50	-17.00
231.76	Peak	34.29	-11.05	23.24	46.00	-22.76
314.21	Peak	30.62	-7.98	22.64	46.00	-23.36
410.24	Peak	33.67	-5.41	28.26	46.00	-17.74
890.39	Peak	26.52	3.43	29.95	46.00	-16.05

Note: 1. No emission found between lowest internal used/generated frequency to 30MHz(9KHz~30MHz)
 2. For below 1GHz, the EUT peak value was under average limit, therefore the Average value compliance with the average limit.

Report No.: T200504W06-RP4

Above 1G

Test Data for UNII-1

Test Mode	IEEE 802.11a / 5180MHZ	Temp/Hum	23.6(°C)/ 45%RH
Test Item	Harmonic	Test Date	May 14, 2020
Polarize	Vertical	Test Engineer	Jerry Chang
Detector	Peak		

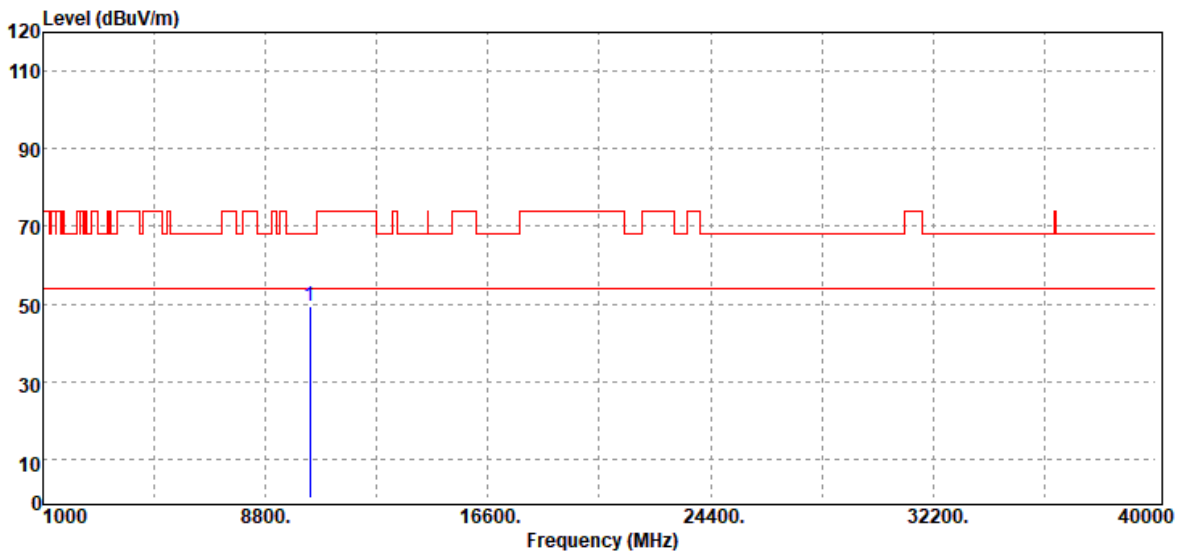

Freq. MHz	Detector Mode PK/QP/AV	Spectrum Reading Level dBμV	Factor dB	Actual FS dBμV/m	Limit @3m dBμV/m	Margin dB
10360.00	Peak	34.50	15.04	49.54	68.20	-18.66
N/A						

Remark:

1. Measuring frequencies from 1 GHz to the 10th harmonic of highest fundamental frequency.
2. For above 1GHz, the EUT peak value was under average limit, therefore the Average value compliance with the average limit

Report No.: T200504W06-RP4

Test Mode	IEEE 802.11a / 5180MHZ	Temp/Hum	23.6(°C)/ 45%RH
Test Item	Harmonic	Test Date	May 14, 2020
Polarize	Horizontal	Test Engineer	Jerry Chang
Detector	Peak		

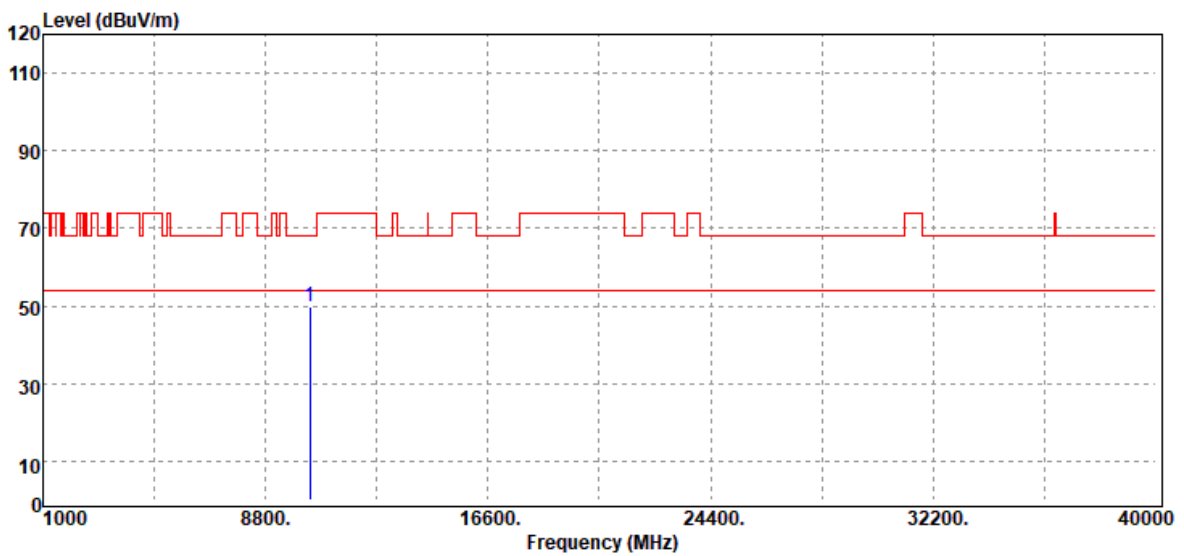

Freq. MHz	Detector Mode PK/QP/AV	Spectrum Reading Level dB μ V	Factor dB	Actual FS dB μ V/m	Limit @3m dB μ V/m	Margin dB
10360.00	Peak	34.67	15.04	49.71	68.20	-18.49
N/A						

Remark:

1. Measuring frequencies from 1 GHz to the 10th harmonic of highest fundamental frequency.
2. For above 1GHz, the EUT peak value was under average limit, therefore the Average value compliance with the average limit

Report No.: T200504W06-RP4

Test Mode	IEEE 802.11a / 5220 MHz	Temp/Hum	23.6(°C)/ 45%RH
Test Item	Harmonics	Test Date	May 14, 2020
Polarize	Vertical	Test Engineer	Jerry Chang
Detector	Peak		

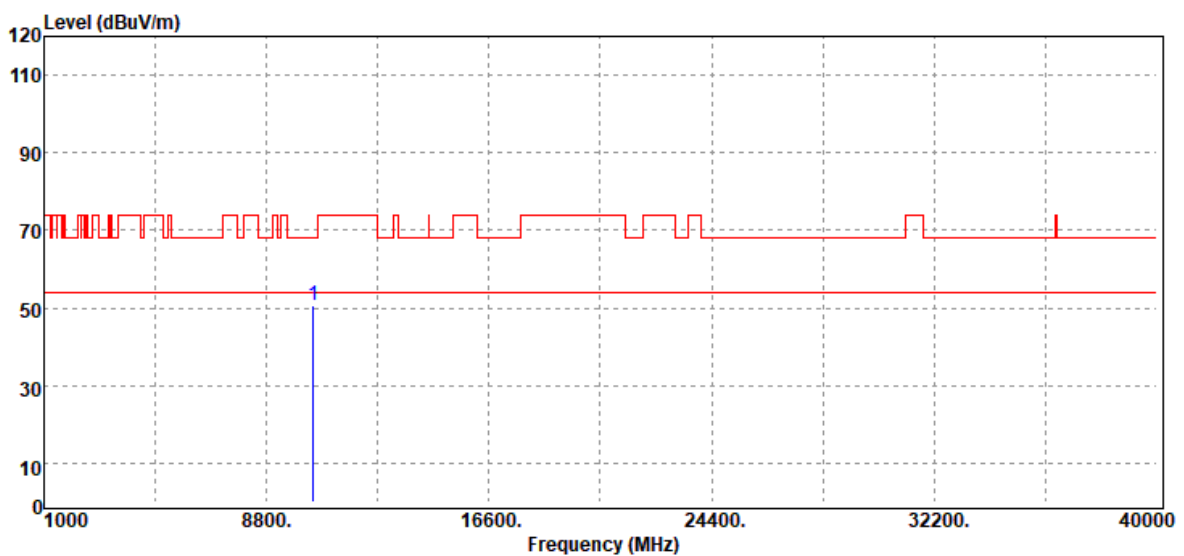

Freq. MHz	Detector Mode PK/QP/AV	Spectrum Reading Level dBμV	Factor dB	Actual FS dBμV/m	Limit @3m dBμV/m	Margin dB
10440.00	Peak	35.37	15.11	50.48	68.20	-17.72
N/A						

Remark:

1. Measuring frequencies from 1 GHz to the 10th harmonic of highest fundamental frequency.
2. For above 1GHz, the EUT peak value was under average limit, therefore the Average value compliance with the average limit

Report No.: T200504W06-RP4

Test Mode	IEEE 802.11a / 5220 MHz	Temp/Hum	23.6(°C)/ 45%RH
Test Item	Harmonic	Test Date	May 14, 2020
Polarize	Horizontal	Test Engineer	Jerry Chang
Detector	Peak		

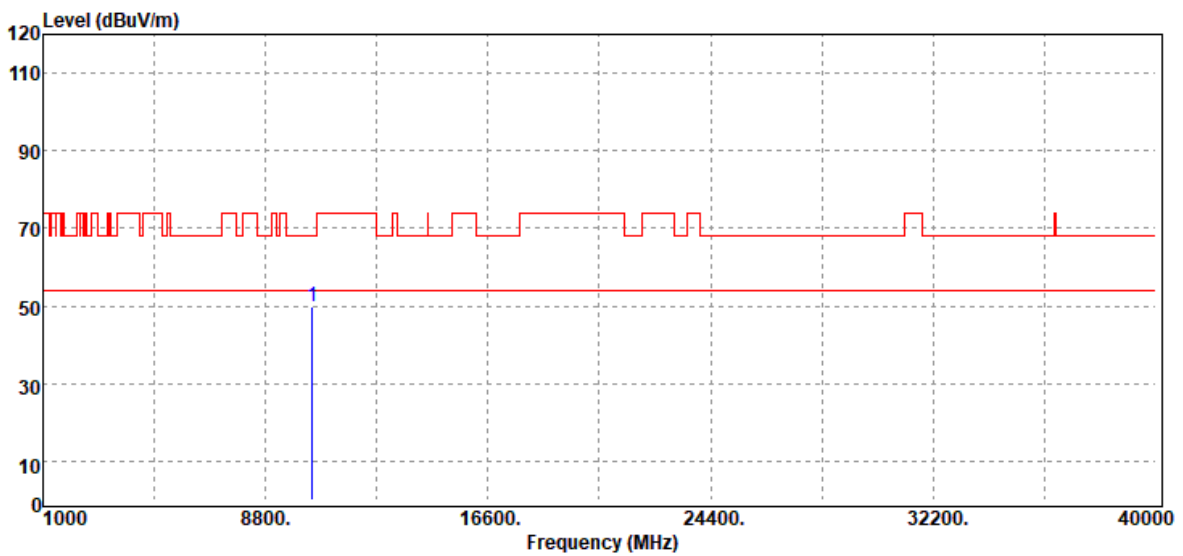

Freq. MHz	Detector Mode PK/QP/AV	Spectrum Reading Level dB μ V	Factor dB	Actual FS dB μ V/m	Limit @3m dB μ V/m	Margin dB
10440.00	Peak	34.61	15.11	49.72	68.20	-18.48
N/A						

Remark:

1. Measuring frequencies from 1 GHz to the 10th harmonic of highest fundamental frequency.
2. For above 1GHz, the EUT peak value was under average limit, therefore the Average value compliance with the average limit

Report No.: T200504W06-RP4

Test Mode	IEEE 802.11a / 5240MHZ	Temp/Hum	23.6(°C)/ 45%RH
Test Item	Harmonic	Test Date	May 14, 2020
Polarize	Vertical	Test Engineer	Jerry Chang
Detector	Peak		

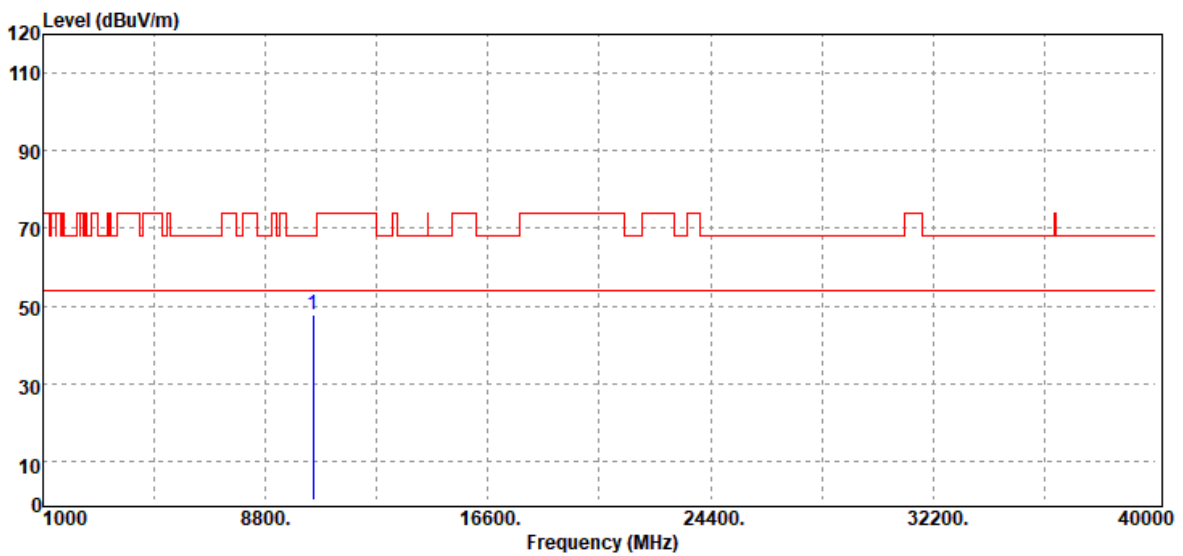

Freq. MHz	Detector Mode PK/QP/AV	Spectrum Reading Level dB μ V	Factor dB	Actual FS dB μ V/m	Limit @3m dB μ V/m	Margin dB
10480.00	Peak	32.67	15.09	47.76	68.20	-20.44
N/A						

Remark:

1. Measuring frequencies from 1 GHz to the 10th harmonic of highest fundamental frequency.
2. For above 1GHz, the EUT peak value was under average limit, therefore the Average value compliance with the average limit

Report No.: T200504W06-RP4

Test Mode	IEEE 802.11a / 5240MHZ	Temp/Hum	23.6(°C)/ 45%RH
Test Item	Harmonic	Test Date	May 14, 2020
Polarize	Horizontal	Test Engineer	Jerry Chang
Detector	Peak		



Freq. MHz	Detector Mode PK/QP/AV	Spectrum Reading Level dB μ V	Factor dB	Actual FS dB μ V/m	Limit @3m dB μ V/m	Margin dB
10480.00	Peak	32.50	15.09	47.59	68.20	-20.61
N/A						

Remark:

1. Measuring frequencies from 1 GHz to the 10th harmonic of highest fundamental frequency.
2. For above 1GHz, the EUT peak value was under average limit, therefore the Average value compliance with the average limit

Report No.: T200504W06-RP4

Test Mode	IEEE 802.11n 20 MHz / 5180MHZ	Temp/Hum	23.6(°C)/ 45%RH
Test Item	Harmonic	Test Date	May 14, 2020
Polarize	Vertical	Test Engineer	Jerry Chang
Detector	Peak		

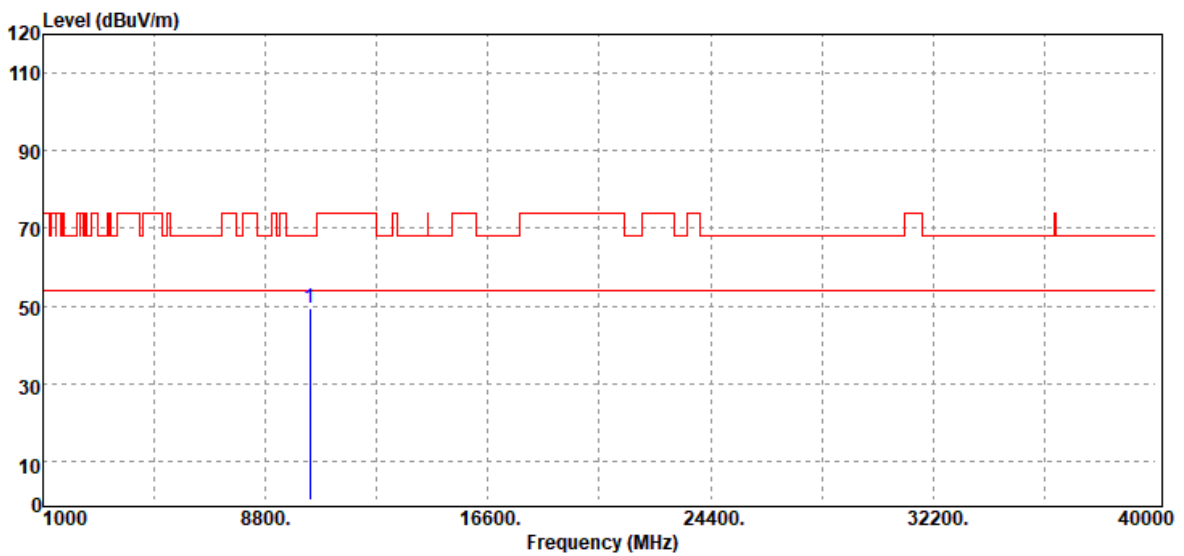

Freq. MHz	Detector Mode PK/QP/AV	Spectrum Reading Level dB μ V	Factor dB	Actual FS dB μ V/m	Limit @3m dB μ V/m	Margin dB
10360.00	Peak	34.48	15.04	49.52	68.20	-18.68
N/A						

Remark:

1. Measuring frequencies from 1 GHz to the 10th harmonic of highest fundamental frequency.
2. For above 1GHz, the EUT peak value was under average limit, therefore the Average value compliance with the average limit

Report No.: T200504W06-RP4

Test Mode	IEEE 802.11n 20 MHz/ 5180MHz	Temp/Hum	23.6(°C)/ 45%RH
Test Item	Harmonic	Test Date	May 14, 2020
Polarize	Horizontal	Test Engineer	Jerry Chang
Detector	Peak		

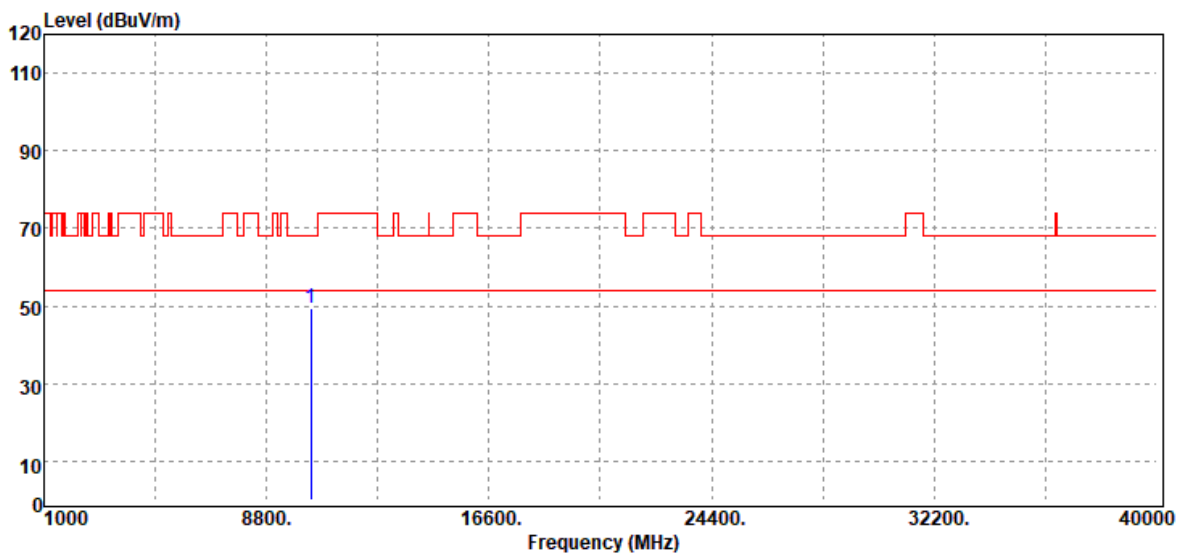

Freq. MHz	Detector Mode PK/QP/AV	Spectrum Reading Level dB μ V	Factor dB	Actual FS dB μ V/m	Limit @3m dB μ V/m	Margin dB
10360.00	Peak	34.42	15.04	49.46	68.20	-18.74
N/A						

Remark:

1. Measuring frequencies from 1 GHz to the 10th harmonic of highest fundamental frequency.
2. For above 1GHz, the EUT peak value was under average limit, therefore the Average value compliance with the average limit

Report No.: T200504W06-RP4

Test Mode	IEEE 802.11n 20 MHz / 5220MHz	Temp/Hum	23.6(°C)/ 45%RH
Test Item	Harmonic	Test Date	May 14, 2020
Polarize	Vertical	Test Engineer	Jerry Chang
Detector	Peak		



Freq. MHz	Detector Mode PK/QP/AV	Spectrum Reading Level dB μ V	Factor dB	Actual FS dB μ V/m	Limit @3m dB μ V/m	Margin dB
10440.00	Peak	32.88	15.11	47.99	68.20	-20.21
N/A						

Remark:

1. Measuring frequencies from 1 GHz to the 10th harmonic of highest fundamental frequency.
2. For above 1GHz, the EUT peak value was under average limit, therefore the Average value compliance with the average limit

Report No.: T200504W06-RP4

Test Mode	IEEE 802.11n 20 MHz / 5220MHz	Temp/Hum	23.6(°C)/ 45%RH
Test Item	Harmonic	Test Date	May 14, 2020
Polarize	Horizontal	Test Engineer	Jerry Chang
Detector	Peak		



Freq. MHz	Detector Mode PK/QP/AV	Spectrum Reading Level dBµV	Factor dB	Actual FS dBµV/m	Limit @3m dBµV/m	Margin dB
10440.00	Peak	34.34	15.11	49.45	68.20	-18.75
N/A						

Remark:

1. Measuring frequencies from 1 GHz to the 10th harmonic of highest fundamental frequency.
2. For above 1GHz, the EUT peak value was under average limit, therefore the Average value compliance with the average limit

Report No.: T200504W06-RP4

Test Mode	IEEE 802.11n 20 MHz / 5240MHZ	Temp/Hum	23.6(°C)/ 45%RH
Test Item	Harmonic	Test Date	May 14, 2020
Polarize	Vertical	Test Engineer	Jerry Chang
Detector	Peak		

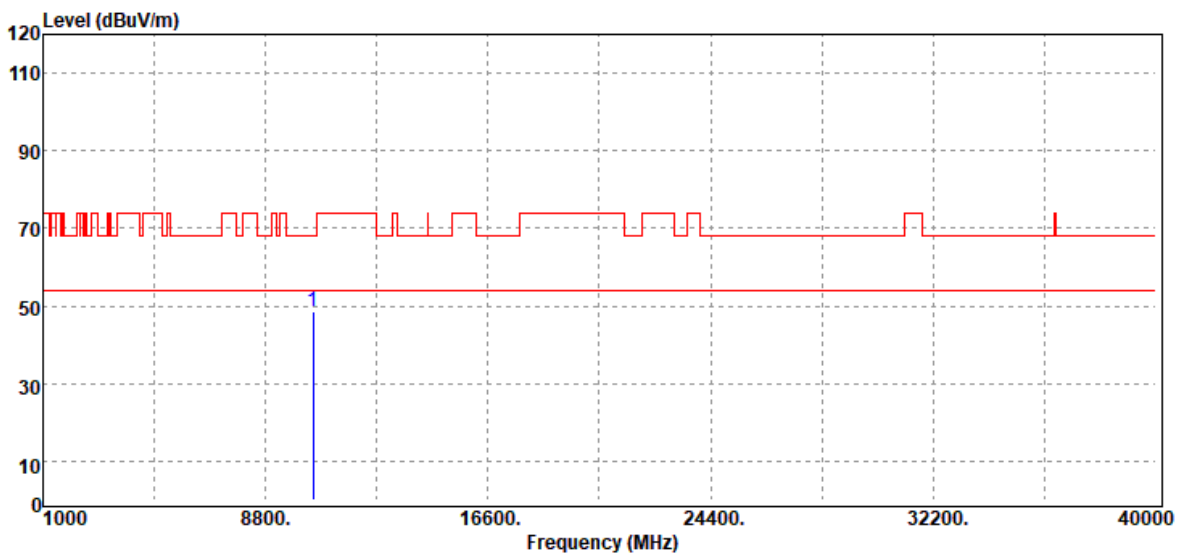

Freq. MHz	Detector Mode PK/QP/AV	Spectrum Reading Level dB μ V	Factor dB	Actual FS dB μ V/m	Limit @3m dB μ V/m	Margin dB
10480.00	Peak	33.47	15.09	48.56	68.20	-19.64
N/A						

Remark:

1. Measuring frequencies from 1 GHz to the 10th harmonic of highest fundamental frequency.
2. For above 1GHz, the EUT peak value was under average limit, therefore the Average value compliance with the average limit

Report No.: T200504W06-RP4

Test Mode	IEEE 802.11n 20 MHz / 5240MHZ	Temp/Hum	23.6(°C)/ 45%RH
Test Item	Harmonic	Test Date	May 14, 2020
Polarize	Horizontal	Test Engineer	Jerry Chang
Detector	Peak		

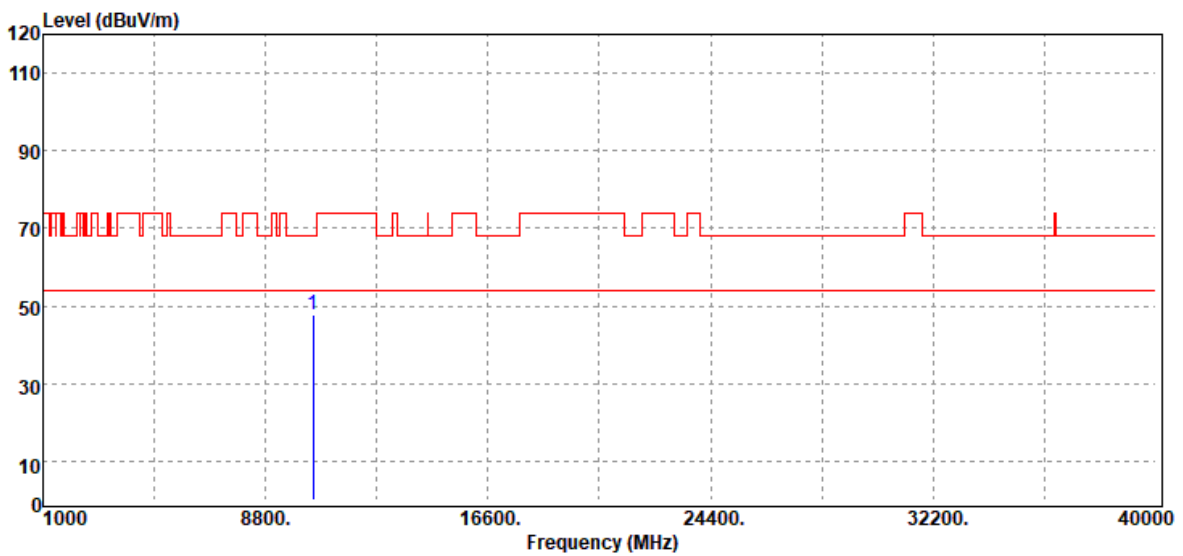

Freq. MHz	Detector Mode PK/QP/AV	Spectrum Reading Level dB μ V	Factor dB	Actual FS dB μ V/m	Limit @3m dB μ V/m	Margin dB
10480.00	Peak	32.61	15.09	47.70	68.20	-20.50
N/A						

Remark:

1. Measuring frequencies from 1 GHz to the 10th harmonic of highest fundamental frequency.
2. For above 1GHz, the EUT peak value was under average limit, therefore the Average value compliance with the average limit

Report No.: T200504W06-RP4

Test Mode	IEEE 802.11n 40 MHz / 5190MHz	Temp/Hum	23.6(°C)/ 45%RH
Test Item	Harmonic	Test Date	May 14, 2020
Polarize	Vertical	Test Engineer	Jerry Chang
Detector	Peak		

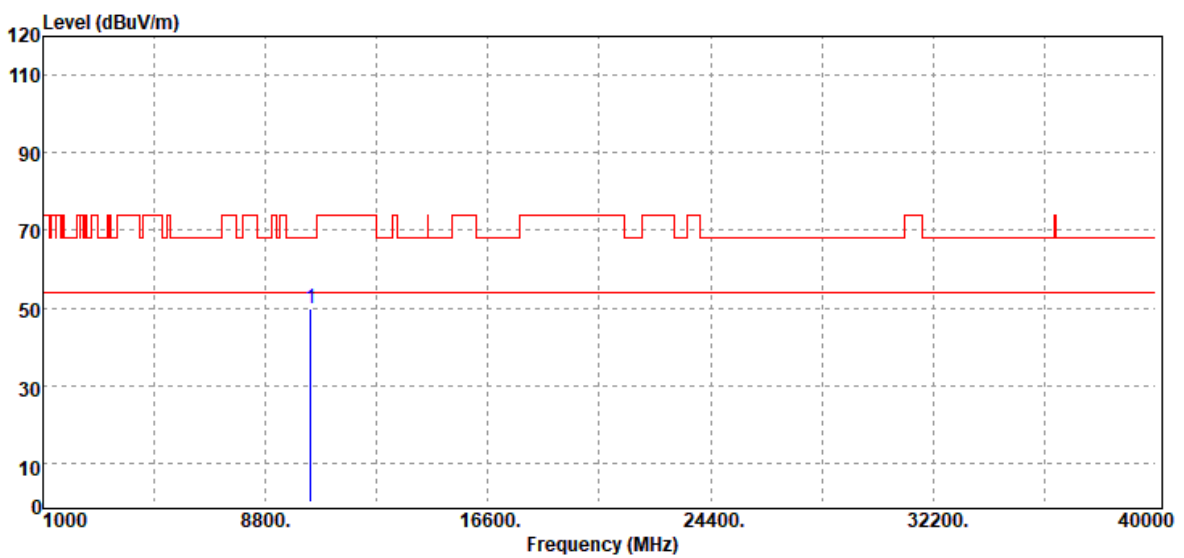

Freq. MHz	Detector Mode PK/QP/AV	Spectrum Reading Level dB μ V	Factor dB	Actual FS dB μ V/m	Limit @3m dB μ V/m	Margin dB
10380.00	Peak	34.82	14.99	49.81	68.20	-18.39
N/A						

Remark:

1. Measuring frequencies from 1 GHz to the 10th harmonic of highest fundamental frequency.
2. For above 1GHz, the EUT peak value was under average limit, therefore the Average value compliance with the average limit

Report No.: T200504W06-RP4

Test Mode	IEEE 802.11n 40 MHz / 5190MHz	Temp/Hum	23.6(°C)/ 45%RH
Test Item	Harmonic	Test Date	May 14, 2020
Polarize	Horizontal	Test Engineer	Jerry Chang
Detector	Peak		

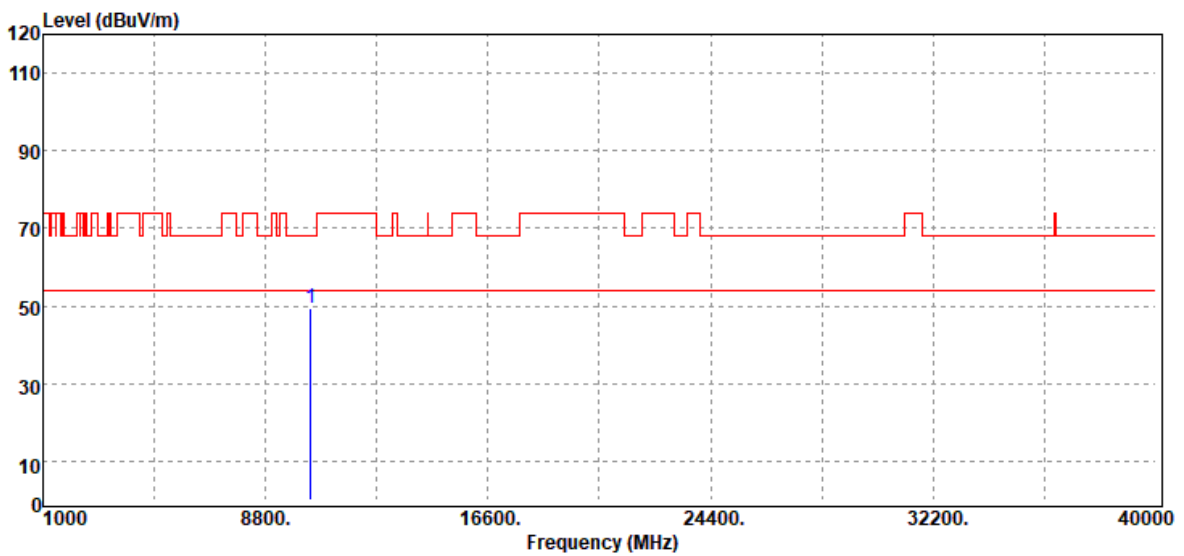

Freq. MHz	Detector Mode PK/QP/AV	Spectrum Reading Level dB μ V	Factor dB	Actual FS dB μ V/m	Limit @3m dB μ V/m	Margin dB
10380.00	Peak	34.26	14.99	49.25	68.20	-18.95
N/A						

Remark:

1. Measuring frequencies from 1 GHz to the 10th harmonic of highest fundamental frequency.
2. For above 1GHz, the EUT peak value was under average limit, therefore the Average value compliance with the average limit

Report No.: T200504W06-RP4

Test Mode	IEEE 802.11n 40 MHz / 5230MHZ	Temp/Hum	23.6(°C)/ 45%RH
Test Item	Harmonic	Test Date	May 14, 2020
Polarize	Vertical	Test Engineer	Jerry Chang
Detector	Peak		



Freq. MHz	Detector Mode PK/QP/AV	Spectrum Reading Level dB μ V	Factor dB	Actual FS dB μ V/m	Limit @3m dB μ V/m	Margin dB
10460.00	Peak	33.52	15.13	48.65	68.20	-19.55
N/A						

Remark:

1. Measuring frequencies from 1 GHz to the 10th harmonic of highest fundamental frequency.
2. For above 1GHz, the EUT peak value was under average limit, therefore the Average value compliance with the average limit

Report No.: T200504W06-RP4

Test Mode	IEEE 802.11n 40 MHz / 5230MHZ	Temp/Hum	23.6(°C)/ 45%RH
Test Item	Harmonic	Test Date	May 14, 2020
Polarize	Horizontal	Test Engineer	Jerry Chang
Detector	Peak		

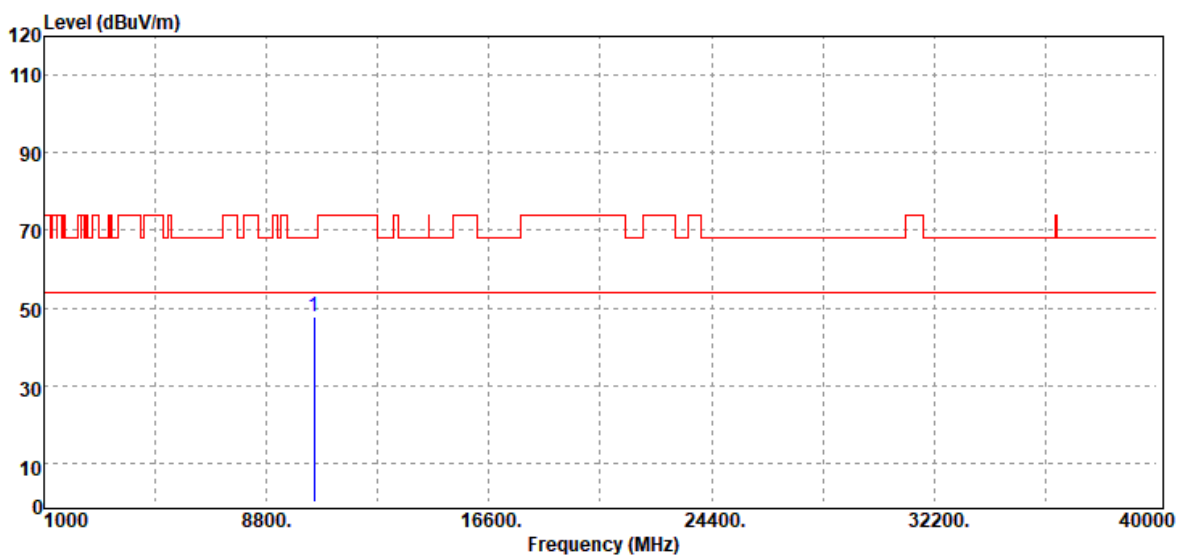

Freq. MHz	Detector Mode PK/QP/AV	Spectrum Reading Level dB μ V	Factor dB	Actual FS dB μ V/m	Limit @3m dB μ V/m	Margin dB
10460.00	Peak	32.70	15.13	47.83	68.20	-20.37
N/A						

Remark:

1. Measuring frequencies from 1 GHz to the 10th harmonic of highest fundamental frequency.
2. For above 1GHz, the EUT peak value was under average limit, therefore the Average value compliance with the average limit

Report No.: T200504W06-RP4

Test Data for UNII-2a

Test Mode	IEEE 802.11a / 5260 MHz	Temp/Hum	23.6(°C)/ 45%RH
Test Item	Harmonic	Test Date	May 14, 2020
Polarize	Vertical	Test Engineer	Jerry Chang
Detector	Peak		

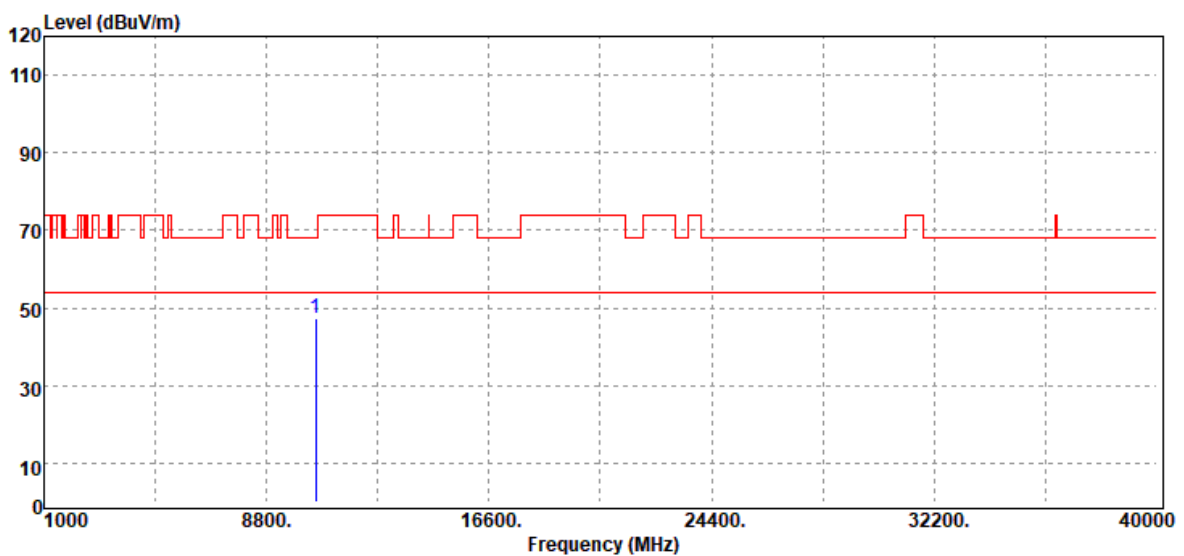

Freq. MHz	Detector Mode PK/QP/AV	Spectrum Reading Level dBμV	Factor dB	Actual FS dBμV/m	Limit @3m dBμV/m	Margin dB
10520.00	Peak	32.18	15.05	47.23	68.20	-20.97
N/A						

Remark:

1. Measuring frequencies from 1 GHz to the 10th harmonic of highest fundamental frequency.
2. For above 1GHz, the EUT peak value was under average limit, therefore the Average value compliance with the average limit

Report No.: T200504W06-RP4

Test Mode	IEEE 802.11a / 5260 MHz	Temp/Hum	23.6(°C)/ 45%RH
Test Item	Harmonic	Test Date	May 14, 2020
Polarize	Horizontal	Test Engineer	Jerry Chang
Detector	Peak		



Freq. MHz	Detector Mode PK/QP/AV	Spectrum Reading Level dB μ V	Factor dB	Actual FS dB μ V/m	Limit @3m dB μ V/m	Margin dB
10520.00	Peak	32.73	15.05	47.78	68.20	-20.42
N/A						

Remark:

1. Measuring frequencies from 1 GHz to the 10th harmonic of highest fundamental frequency.
2. For above 1GHz, the EUT peak value was under average limit, therefore the Average value compliance with the average limit

Report No.: T200504W06-RP4

Test Mode	IEEE 802.11a / 5280 MHz	Temp/Hum	23.6(°C)/ 45%RH
Test Item	Harmonic	Test Date	May 14, 2020
Polarize	Vertical	Test Engineer	Jerry Chang
Detector	Peak		



Freq. MHz	Detector Mode PK/QP/AV	Spectrum Reading Level dBμV	Factor dB	Actual FS dBμV/m	Limit @3m dBμV/m	Margin dB
10560.00	Peak	33.54	15.05	48.59	68.20	-19.61
N/A						

Remark:

1. Measuring frequencies from 1 GHz to the 10th harmonic of highest fundamental frequency.
2. For above 1GHz, the EUT peak value was under average limit, therefore the Average value compliance with the average limit

Report No.: T200504W06-RP4

Test Mode	IEEE 802.11a / 5280 MHz	Temp/Hum	23.6(°C)/ 45%RH
Test Item	Harmonic	Test Date	May 14, 2020
Polarize	Horizontal	Test Engineer	Jerry Chang
Detector	Peak		



Freq. MHz	Detector Mode PK/QP/AV	Spectrum Reading Level dB μ V	Factor dB	Actual FS dB μ V/m	Limit @3m dB μ V/m	Margin dB
10560.00	Peak	33.34	15.05	48.39	68.20	-19.81
N/A						

Remark:

1. Measuring frequencies from 1 GHz to the 10th harmonic of highest fundamental frequency.
2. For above 1GHz, the EUT peak value was under average limit, therefore the Average value compliance with the average limit

Report No.: T200504W06-RP4

Test Mode	IEEE 802.11a / 5320 MHz	Temp/Hum	23.6(°C)/ 45%RH
Test Item	Harmonic	Test Date	May 14, 2020
Polarize	Vertical	Test Engineer	Jerry Chang
Detector	Peak		

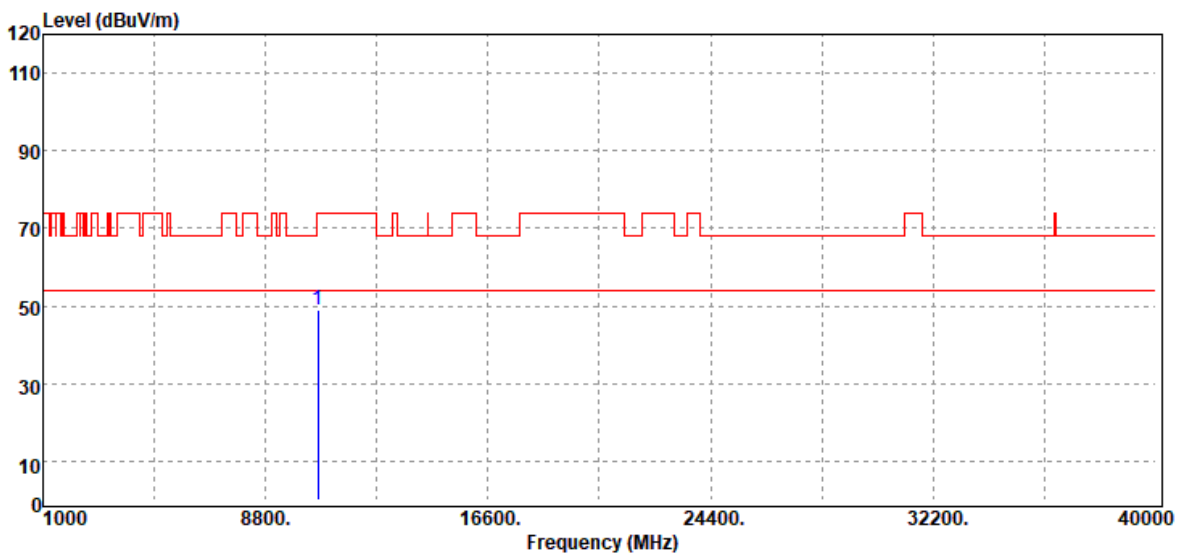

Freq. MHz	Detector Mode PK/QP/AV	Spectrum Reading Level dBμV	Factor dB	Actual FS dBμV/m	Limit @3m dBμV/m	Margin dB
10640.00	Peak	33.52	15.51	49.03	74.00	-24.97
N/A						

Remark:

1. Measuring frequencies from 1 GHz to the 10th harmonic of highest fundamental frequency.
2. For above 1GHz, the EUT peak value was under average limit, therefore the Average value compliance with the average limit

Report No.: T200504W06-RP4

Test Mode	IEEE 802.11a / 5320 MHz	Temp/Hum	23.6(°C)/ 45%RH
Test Item	Harmonic	Test Date	May 14, 2020
Polarize	Horizontal	Test Engineer	Jerry Chang
Detector	Peak		



Freq. MHz	Detector Mode PK/QP/AV	Spectrum Reading Level dB μ V	Factor dB	Actual FS dB μ V/m	Limit @3m dB μ V/m	Margin dB
10640.00	Peak	33.73	15.51	49.24	74.00	-24.76
N/A						

Remark:

1. Measuring frequencies from 1 GHz to the 10th harmonic of highest fundamental frequency.
2. For above 1GHz, the EUT peak value was under average limit, therefore the Average value compliance with the average limit

Report No.: T200504W06-RP4

Test Mode	IEEE 802.11n 20 MHz / 5260 MHz	Temp/Hum	23.6(°C)/ 45%RH
Test Item	Harmonic	Test Date	May 14, 2020
Polarize	Vertical	Test Engineer	Jerry Chang
Detector	Peak		

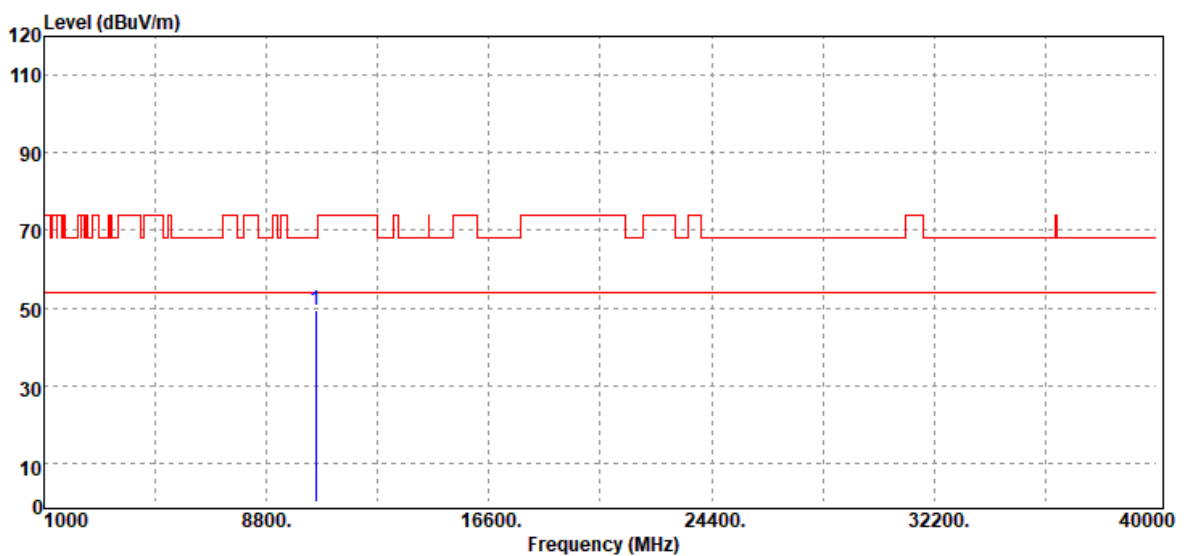

Freq. MHz	Detector Mode PK/QP/AV	Spectrum Reading Level dB μ V	Factor dB	Actual FS dB μ V/m	Limit @3m dB μ V/m	Margin dB
10520.00	Peak	34.29	15.05	49.34	68.20	-18.86
N/A						

Remark:

1. Measuring frequencies from 1 GHz to the 10th harmonic of highest fundamental frequency.
2. For above 1GHz, the EUT peak value was under average limit, therefore the Average value compliance with the average limit

Report No.: T200504W06-RP4

Test Mode	IEEE 802.11n 20 MHz / 5260 MHz	Temp/Hum	23.6(°C)/ 45%RH
Test Item	Harmonic	Test Date	May 14, 2020
Polarize	Horizontal	Test Engineer	Jerry Chang
Detector	Peak		



Freq. MHz	Detector Mode PK/QP/AV	Spectrum Reading Level dBμV	Factor dB	Actual FS dBμV/m	Limit @3m dBμV/m	Margin dB
10520.00	Peak	33.20	15.05	48.25	68.20	-19.95
N/A						

Remark:

1. Measuring frequencies from 1 GHz to the 10th harmonic of highest fundamental frequency.
2. For above 1GHz, the EUT peak value was under average limit, therefore the Average value compliance with the average limit

Report No.: T200504W06-RP4

Test Mode	IEEE 802.11n 20 MHz / 5280 MHz	Temp/Hum	23.6(°C)/ 45%RH
Test Item	Harmonic	Test Date	May 14, 2020
Polarize	Vertical	Test Engineer	Jerry Chang
Detector	Peak		

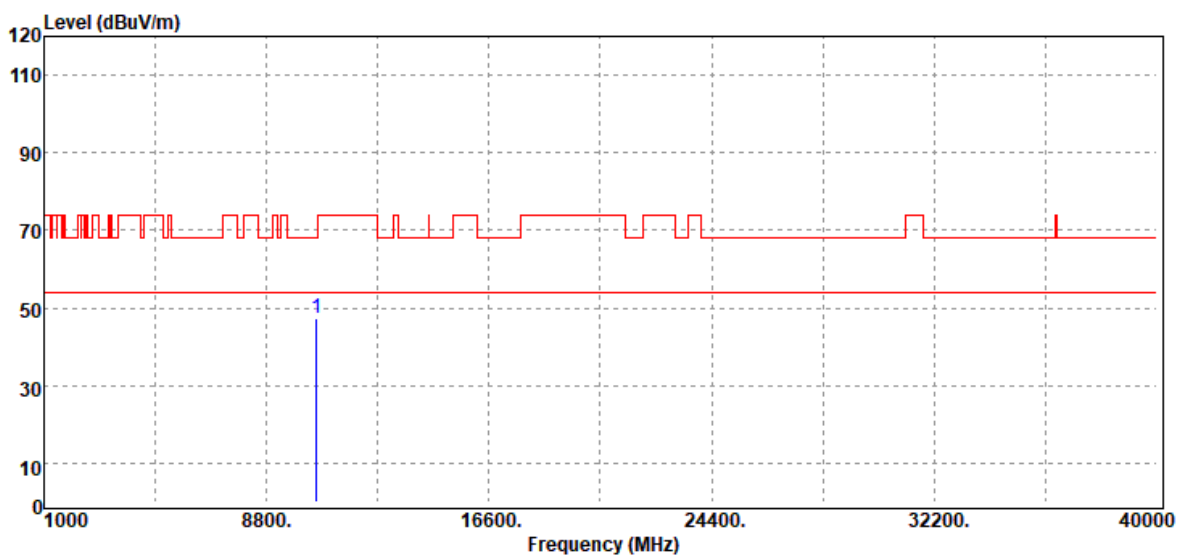

Freq. MHz	Detector Mode PK/QP/AV	Spectrum Reading Level dB μ V	Factor dB	Actual FS dB μ V/m	Limit @3m dB μ V/m	Margin dB
10560.00	Peak	32.25	15.05	47.30	68.20	-20.90
N/A						

Remark:

1. Measuring frequencies from 1 GHz to the 10th harmonic of highest fundamental frequency.
2. For above 1GHz, the EUT peak value was under average limit, therefore the Average value compliance with the average limit

Report No.: T200504W06-RP4

Test Mode	IEEE 802.11n 20 MHz / 5280 MHz	Temp/Hum	23.6(°C)/ 45%RH
Test Item	Harmonic	Test Date	May 14, 2020
Polarize	Horizontal	Test Engineer	Jerry Chang
Detector	Peak		



Freq. MHz	Detector Mode PK/QP/AV	Spectrum Reading Level dB μ V	Factor dB	Actual FS dB μ V/m	Limit @3m dB μ V/m	Margin dB
10560.00	Peak	32.62	15.05	47.67	68.20	-20.53
N/A						

Remark:

1. Measuring frequencies from 1 GHz to the 10th harmonic of highest fundamental frequency.
2. For above 1GHz, the EUT peak value was under average limit, therefore the Average value compliance with the average limit

Report No.: T200504W06-RP4

Test Mode	IEEE 802.11n 20 MHz / 5320 MHz	Temp/Hum	23.6(°C)/ 45%RH
Test Item	Harmonic	Test Date	May 14, 2020
Polarize	Vertical	Test Engineer	Jerry Chang
Detector	Peak		

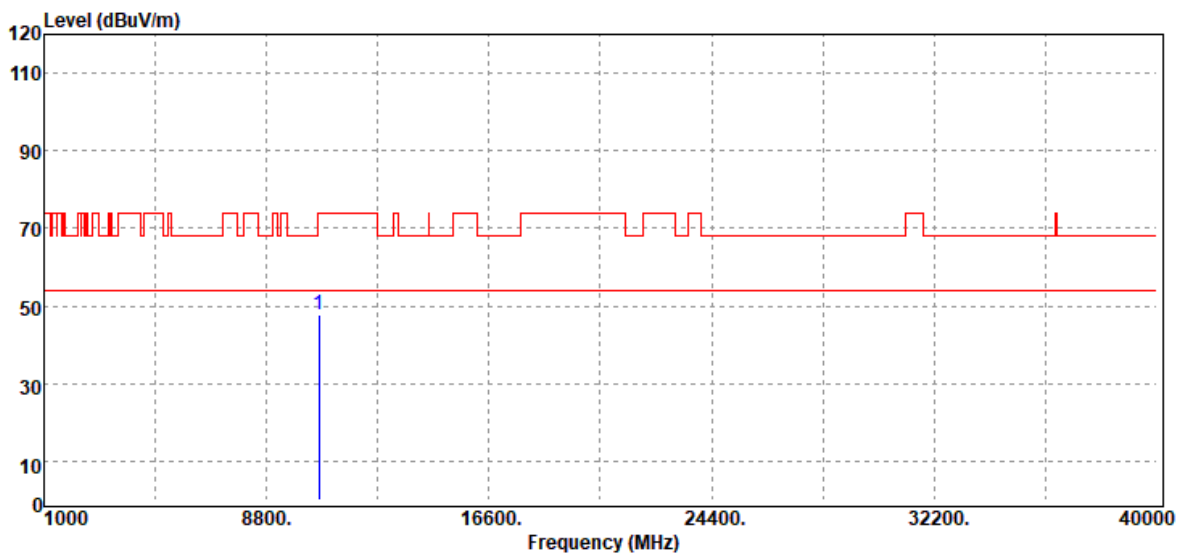

Freq. MHz	Detector Mode PK/QP/AV	Spectrum Reading Level dB μ V	Factor dB	Actual FS dB μ V/m	Limit @3m dB μ V/m	Margin dB
10640.00	Peak	32.44	15.51	47.95	74.00	-26.05
N/A						

Remark:

1. Measuring frequencies from 1 GHz to the 10th harmonic of highest fundamental frequency.
2. For above 1GHz, the EUT peak value was under average limit, therefore the Average value compliance with the average limit

Report No.: T200504W06-RP4

Test Mode	IEEE 802.11n 20 MHz / 5320 MHz	Temp/Hum	23.6(°C)/ 45%RH
Test Item	Harmonic	Test Date	May 14, 2020
Polarize	Horizontal	Test Engineer	Jerry Chang
Detector	Peak		

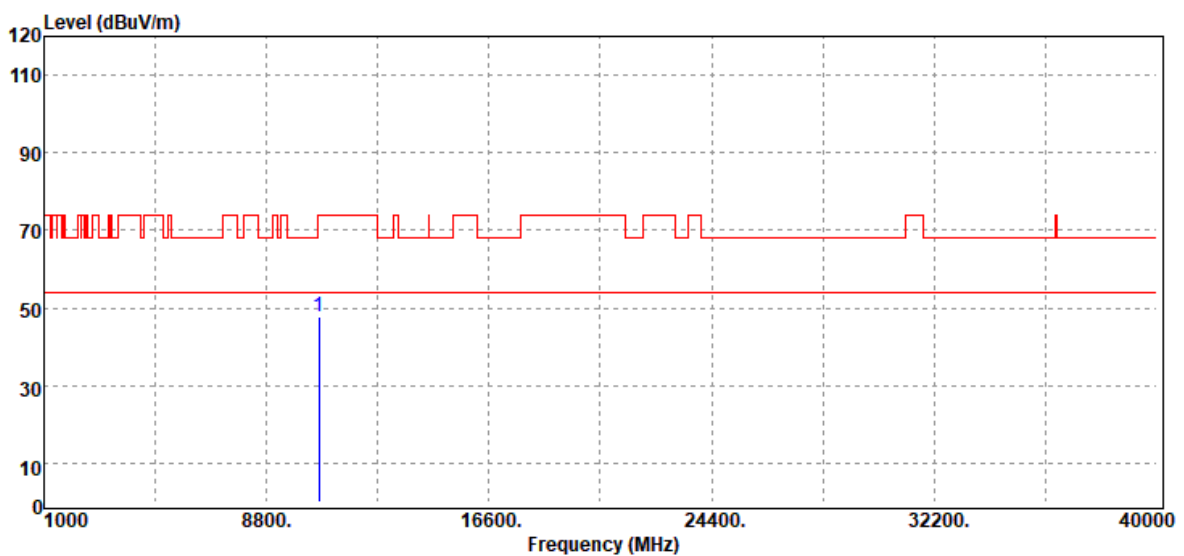

Freq. MHz	Detector Mode PK/QP/AV	Spectrum Reading Level dB μ V	Factor dB	Actual FS dB μ V/m	Limit @3m dB μ V/m	Margin dB
10640.00	Peak	32.29	15.51	47.80	74.00	-26.20
N/A						

Remark:

1. Measuring frequencies from 1 GHz to the 10th harmonic of highest fundamental frequency.
2. For above 1GHz, the EUT peak value was under average limit, therefore the Average value compliance with the average limit

Report No.: T200504W06-RP4

Test Mode	IEEE 802.11n 40 MHz / 5270 MHz	Temp/Hum	23.6(°C)/ 45%RH
Test Item	Harmonic	Test Date	May 14, 2020
Polarize	Vertical	Test Engineer	Jerry Chang
Detector	Peak		



Freq. MHz	Detector Mode PK/QP/AV	Spectrum Reading Level dB μ V	Factor dB	Actual FS dB μ V/m	Limit @3m dB μ V/m	Margin dB
10540.00	Peak	32.17	15.05	47.22	68.20	-20.98
N/A						

Remark:

1. Measuring frequencies from 1 GHz to the 10th harmonic of highest fundamental frequency.
2. For above 1GHz, the EUT peak value was under average limit, therefore the Average value compliance with the average limit

Report No.: T200504W06-RP4

Test Mode	IEEE 802.11n 40 MHz / 5270 MHz	Temp/Hum	23.6(°C)/ 45%RH
Test Item	Harmonic	Test Date	May 14, 2020
Polarize	Horizontal	Test Engineer	Jerry Chang
Detector	Peak		



Freq. MHz	Detector Mode PK/QP/AV	Spectrum Reading Level dBμV	Factor dB	Actual FS dBμV/m	Limit @3m dBμV/m	Margin dB
10540.00	Peak	32.73	15.05	47.78	68.20	-20.42
N/A						

Remark:

1. Measuring frequencies from 1 GHz to the 10th harmonic of highest fundamental frequency.
2. For above 1GHz, the EUT peak value was under average limit, therefore the Average value compliance with the average limit

Report No.: T200504W06-RP4

Test Mode	IEEE 802.11n 40 MHz / 5310 MHz	Temp/Hum	23.6(°C)/ 45%RH
Test Item	Harmonic	Test Date	May 14, 2020
Polarize	Vertical	Test Engineer	Jerry Chang
Detector	Peak		

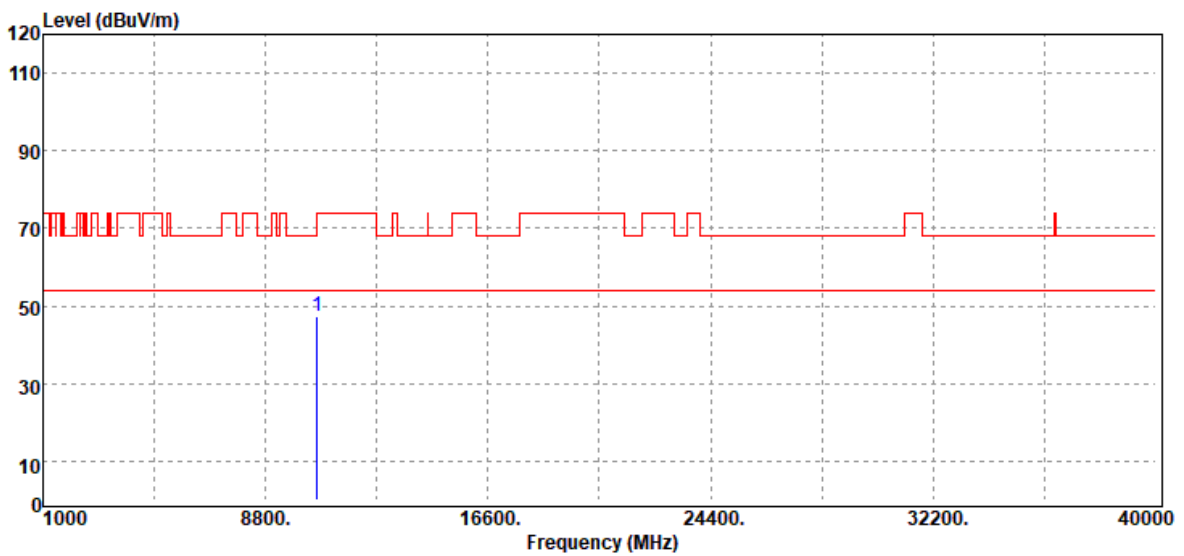

Freq. MHz	Detector Mode PK/QP/AV	Spectrum Reading Level dB μ V	Factor dB	Actual FS dB μ V/m	Limit @3m dB μ V/m	Margin dB
10620.00	Peak	32.02	15.28	47.30	74.00	-26.70
N/A						

Remark:

1. Measuring frequencies from 1 GHz to the 10th harmonic of highest fundamental frequency.
2. For above 1GHz, the EUT peak value was under average limit, therefore the Average value compliance with the average limit

Report No.: T200504W06-RP4

Test Mode	IEEE 802.11n 40 MHz / 5310 MHz	Temp/Hum	23.6(°C)/ 45%RH
Test Item	Harmonic	Test Date	May 14, 2020
Polarize	Horizontal	Test Engineer	Jerry Chang
Detector	Peak		



Freq. MHz	Detector Mode PK/QP/AV	Spectrum Reading Level dB μ V	Factor dB	Actual FS dB μ V/m	Limit @3m dB μ V/m	Margin dB
10620.00	Peak	32.09	15.28	47.37	74.00	-26.63
N/A						

Remark:

1. Measuring frequencies from 1 GHz to the 10th harmonic of highest fundamental frequency.
2. For above 1GHz, the EUT peak value was under average limit, therefore the Average value compliance with the average limit

Report No.: T200504W06-RP4

Test Data for UNII-2c

Test Mode	IEEE 802.11a / 5500 MHz	Temp/Hum	23.6(°C)/ 45%RH
Test Item	Harmonic	Test Date	May 14, 2020
Polarize	Vertical	Test Engineer	Jerry Chang
Detector	Peak		

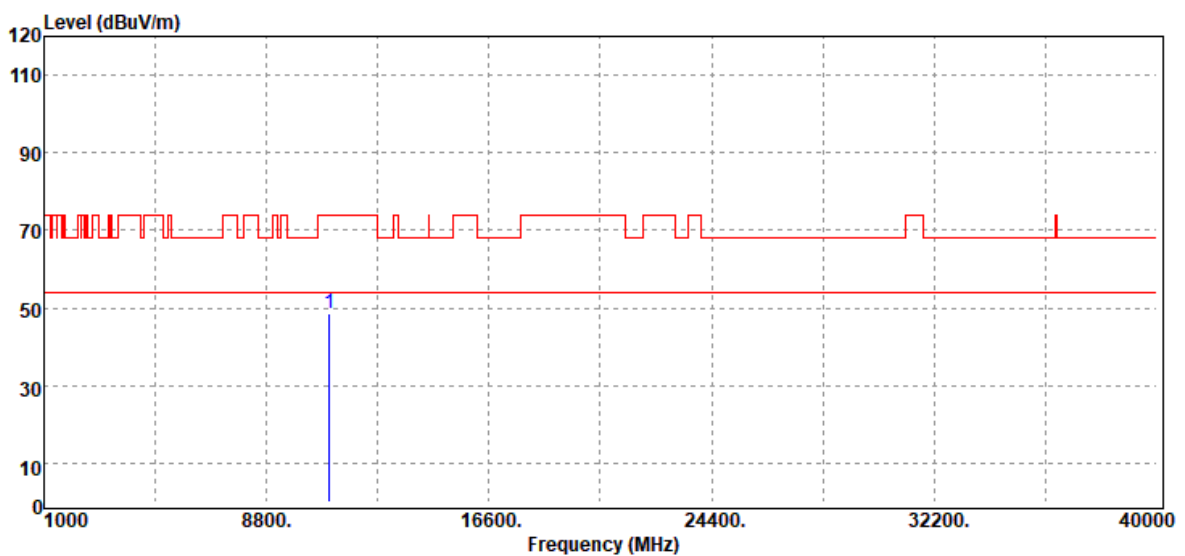

Freq. MHz	Detector Mode PK/QP/AV	Spectrum Reading Level dBμV	Factor dB	Actual FS dBμV/m	Limit @3m dBμV/m	Margin dB
11000.00	Peak	32.49	16.02	48.51	74.00	-25.49
N/A						

Remark:

1. Measuring frequencies from 1 GHz to the 10th harmonic of highest fundamental frequency.
2. For above 1GHz, the EUT peak value was under average limit, therefore the Average value compliance with the average limit

Report No.: T200504W06-RP4

Test Mode	IEEE 802.11a / 5500 MHz	Temp/Hum	23.6(°C)/ 45%RH
Test Item	Harmonic	Test Date	May 14, 2020
Polarize	Horizontal	Test Engineer	Jerry Chang
Detector	Peak		

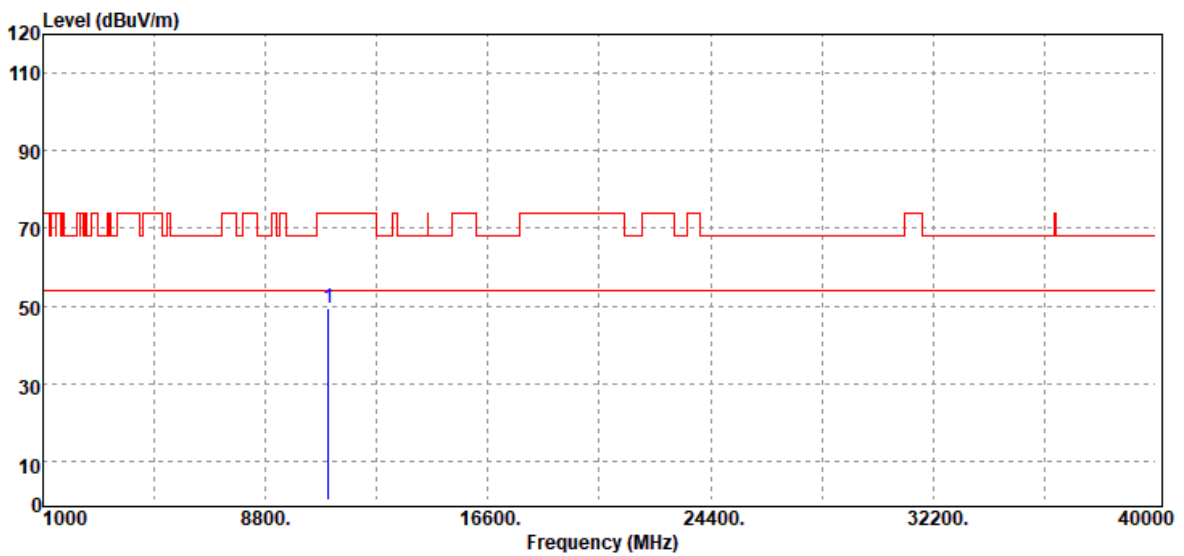

Freq. MHz	Detector Mode PK/QP/AV	Spectrum Reading Level dB μ V	Factor dB	Actual FS dB μ V/m	Limit @3m dB μ V/m	Margin dB
11000.00	Peak	33.54	16.02	49.56	74.00	-24.44
N/A						

Remark:

1. Measuring frequencies from 1 GHz to the 10th harmonic of highest fundamental frequency.
2. For above 1GHz, the EUT peak value was under average limit, therefore the Average value compliance with the average limit

Report No.: T200504W06-RP4

Test Mode	IEEE 802.11a / 5580 MHz	Temp/Hum	23.6(°C)/ 45%RH
Test Item	Harmonic	Test Date	May 14, 2020
Polarize	Vertical	Test Engineer	Jerry Chang
Detector	Peak		



Freq. MHz	Detector Mode PK/QP/AV	Spectrum Reading Level dB μ V	Factor dB	Actual FS dB μ V/m	Limit @3m dB μ V/m	Margin dB
11160.00	Peak	33.03	16.70	49.73	74.00	-24.27
N/A						

Remark:

1. Measuring frequencies from 1 GHz to the 10th harmonic of highest fundamental frequency.
2. For above 1GHz, the EUT peak value was under average limit, therefore the Average value compliance with the average limit

Report No.: T200504W06-RP4

Test Mode	IEEE 802.11a / 5580 MHz	Temp/Hum	23.6(°C)/ 45%RH
Test Item	Harmonic	Test Date	May 14, 2020
Polarize	Horizontal	Test Engineer	Jerry Chang
Detector	Peak		

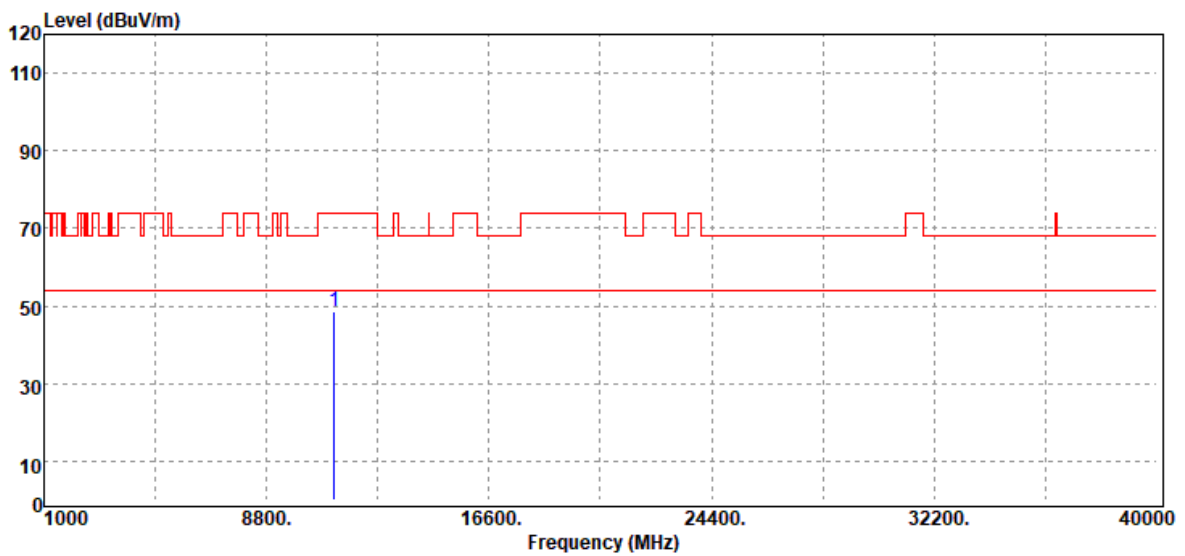

Freq. MHz	Detector Mode PK/QP/AV	Spectrum Reading Level d μ V	Factor dB	Actual FS d μ V/m	Limit @3m d μ V/m	Margin dB
11160.00	Peak	31.73	16.70	48.43	74.00	-25.57
N/A						

Remark:

1. Measuring frequencies from 1 GHz to the 10th harmonic of highest fundamental frequency.
2. For above 1GHz, the EUT peak value was under average limit, therefore the Average value compliance with the average limit

Report No.: T200504W06-RP4

Test Mode	IEEE 802.11a / 5700 MHz	Temp/Hum	23.6(°C)/ 45%RH
Test Item	Harmonic	Test Date	May 14, 2020
Polarize	Vertical	Test Engineer	Jerry Chang
Detector	Peak		

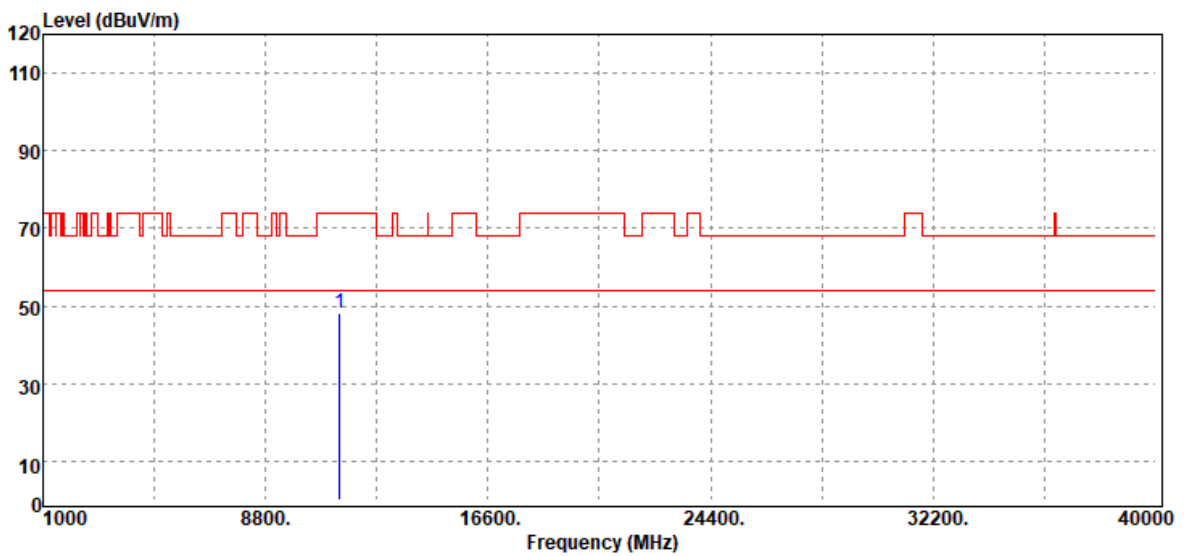

Freq. MHz	Detector Mode PK/QP/AV	Spectrum Reading Level dB μ V	Factor dB	Actual FS dB μ V/m	Limit @3m dB μ V/m	Margin dB
11400.00	Peak	31.83	16.18	48.01	74.00	-25.99
N/A						

Remark:

1. Measuring frequencies from 1 GHz to the 10th harmonic of highest fundamental frequency.
2. For above 1GHz, the EUT peak value was under average limit, therefore the Average value compliance with the average limit

Report No.: T200504W06-RP4

Test Mode	IEEE 802.11a / 5700 MHz	Temp/Hum	23.6(°C)/ 45%RH
Test Item	Harmonic	Test Date	May 14, 2020
Polarize	Horizontal	Test Engineer	Jerry Chang
Detector	Peak		



Freq. MHz	Detector Mode PK/QP/AV	Spectrum Reading Level dB μ V	Factor dB	Actual FS dB μ V/m	Limit @3m dB μ V/m	Margin dB
11400.00	Peak	31.61	16.18	47.79	74.00	-26.21
N/A						

Remark:

1. Measuring frequencies from 1 GHz to the 10th harmonic of highest fundamental frequency.
2. For above 1GHz, the EUT peak value was under average limit, therefore the Average value compliance with the average limit

Report No.: T200504W06-RP4

Test Mode	IEEE 802.11n 20 MHz / 5500 MHz	Temp/Hum	23.6(°C)/ 45%RH
Test Item	Harmonic	Test Date	May 14, 2020
Polarize	Vertical	Test Engineer	Jerry Chang
Detector	Peak		



Freq. MHz	Detector Mode PK/QP/AV	Spectrum Reading Level dB μ V	Factor dB	Actual FS dB μ V/m	Limit @3m dB μ V/m	Margin dB
11000.00	Peak	33.09	16.02	49.11	74.00	-24.89
N/A						

Remark:

1. Measuring frequencies from 1 GHz to the 10th harmonic of highest fundamental frequency.
2. For above 1GHz, the EUT peak value was under average limit, therefore the Average value compliance with the average limit

Report No.: T200504W06-RP4

Test Mode	IEEE 802.11n 20 MHz / 5500 MHz	Temp/Hum	23.6(°C)/ 45%RH
Test Item	Harmonic	Test Date	May 14, 2020
Polarize	Horizontal	Test Engineer	Jerry Chang
Detector	Peak		

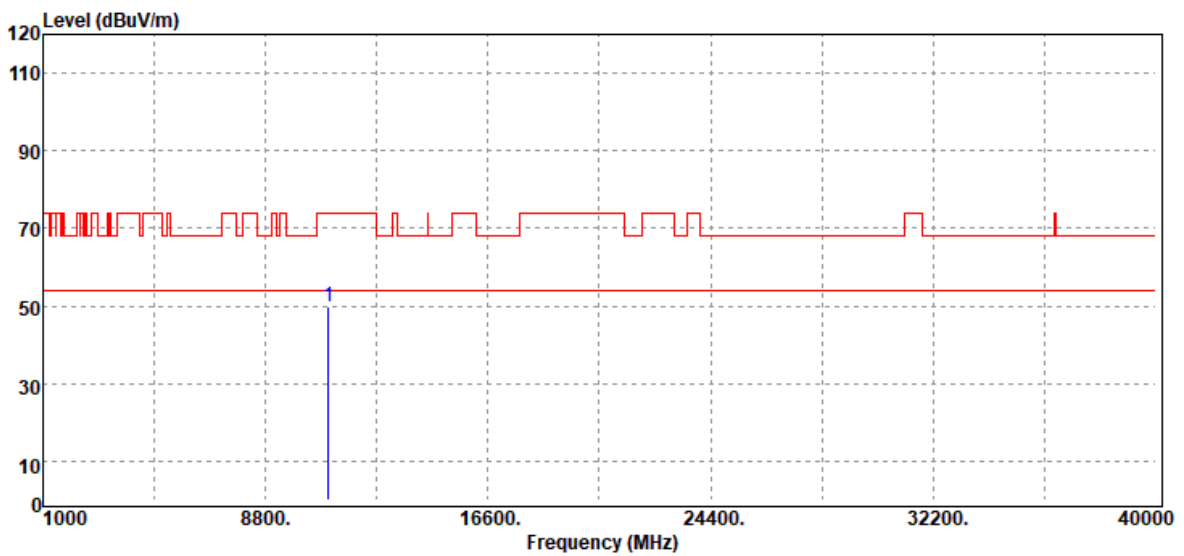

Freq. MHz	Detector Mode PK/QP/AV	Spectrum Reading Level dB μ V	Factor dB	Actual FS dB μ V/m	Limit @3m dB μ V/m	Margin dB
11000.00	Peak	33.99	16.02	50.01	74.00	-23.99
N/A						

Remark:

1. Measuring frequencies from 1 GHz to the 10th harmonic of highest fundamental frequency.
2. For above 1GHz, the EUT peak value was under average limit, therefore the Average value compliance with the average limit

Report No.: T200504W06-RP4

Test Mode	IEEE 802.11n 20 MHz / 5580 MHz	Temp/Hum	23.6(°C)/ 45%RH
Test Item	Harmonic	Test Date	May 14, 2020
Polarize	Vertical	Test Engineer	Jerry Chang
Detector	Peak		



Freq. MHz	Detector Mode PK/QP/AV	Spectrum Reading Level dB μ V	Factor dB	Actual FS dB μ V/m	Limit @3m dB μ V/m	Margin dB
11160.00	Peak	32.41	16.70	49.11	74.00	-24.89
N/A						

Remark:

1. Measuring frequencies from 1 GHz to the 10th harmonic of highest fundamental frequency.
2. For above 1GHz, the EUT peak value was under average limit, therefore the Average value compliance with the average limit

Report No.: T200504W06-RP4

Test Mode	IEEE 802.11n 20 MHz / 5580 MHz	Temp/Hum	23.6(°C)/ 45%RH
Test Item	Harmonic	Test Date	May 14, 2020
Polarize	Horizontal	Test Engineer	Jerry Chang
Detector	Peak		



Freq. MHz	Detector Mode PK/QP/AV	Spectrum Reading Level dB μ V	Factor dB	Actual FS dB μ V/m	Limit @3m dB μ V/m	Margin dB
11160.00	Peak	32.96	16.70	49.66	74.00	-24.34
N/A						

Remark:

1. Measuring frequencies from 1 GHz to the 10th harmonic of highest fundamental frequency.
2. For above 1GHz, the EUT peak value was under average limit, therefore the Average value compliance with the average limit

Report No.: T200504W06-RP4

Test Mode	IEEE 802.11n 20 MHz / 5700 MHz	Temp/Hum	23.6(°C)/ 45%RH
Test Item	Harmonic	Test Date	May 14, 2020
Polarize	Vertical	Test Engineer	Jerry Chang
Detector	Peak		

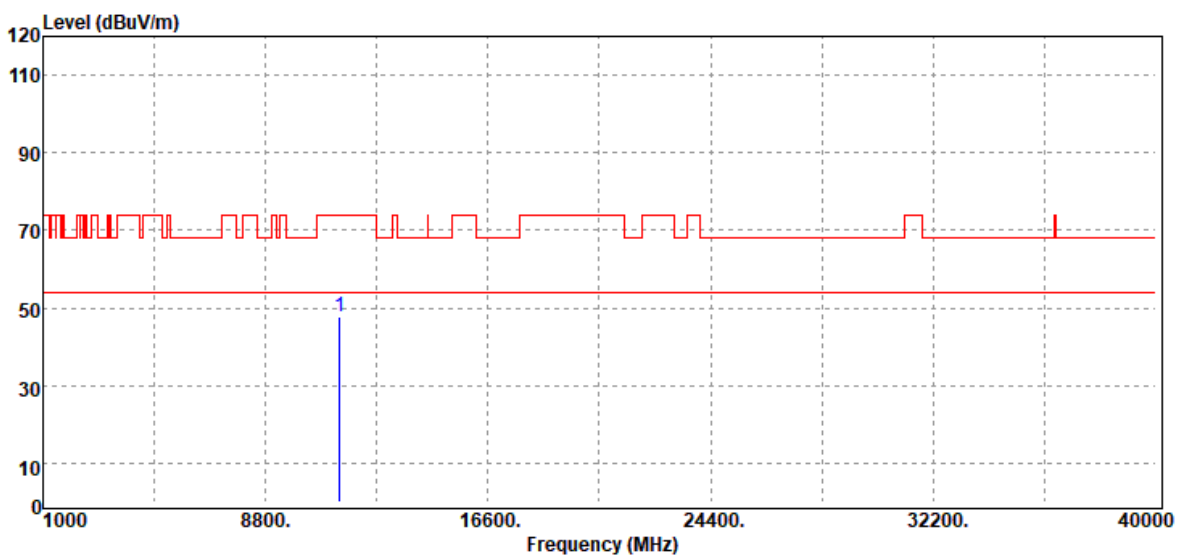

Freq. MHz	Detector Mode PK/QP/AV	Spectrum Reading Level dBμV	Factor dB	Actual FS dBμV/m	Limit @3m dBμV/m	Margin dB
11400.00	Peak	31.75	16.18	47.93	74.00	-26.07
N/A						

Remark:

1. Measuring frequencies from 1 GHz to the 10th harmonic of highest fundamental frequency.
2. For above 1GHz, the EUT peak value was under average limit, therefore the Average value compliance with the average limit

Report No.: T200504W06-RP4

Test Mode	IEEE 802.11n 20 MHz / 5700 MHz	Temp/Hum	23.6(°C)/ 45%RH
Test Item	Harmonic	Test Date	May 14, 2020
Polarize	Horizontal	Test Engineer	Jerry Chang
Detector	Peak		

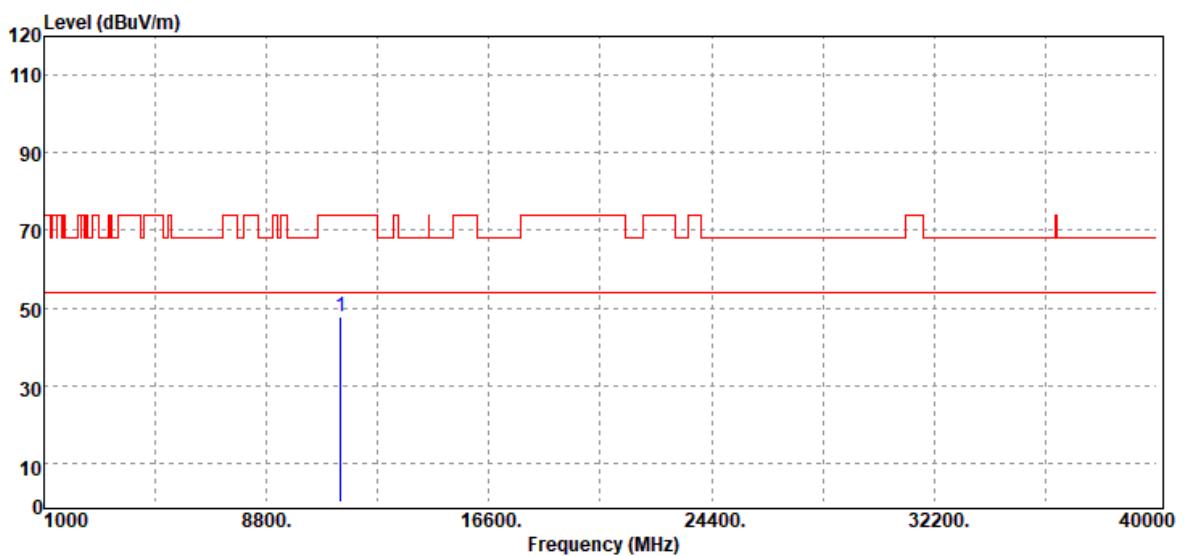

Freq. MHz	Detector Mode PK/QP/AV	Spectrum Reading Level dB μ V	Factor dB	Actual FS dB μ V/m	Limit @3m dB μ V/m	Margin dB
11400.00	Peak	31.57	16.18	47.75	74.00	-26.25
N/A						

Remark:

1. Measuring frequencies from 1 GHz to the 10th harmonic of highest fundamental frequency.
2. For above 1GHz, the EUT peak value was under average limit, therefore the Average value compliance with the average limit

Report No.: T200504W06-RP4

Test Mode	IEEE 802.11n 40 MHz / 5510 MHz	Temp/Hum	23.6(°C)/ 45%RH
Test Item	Harmonic	Test Date	May 14, 2020
Polarize	Vertical	Test Engineer	Jerry Chang
Detector	Peak		

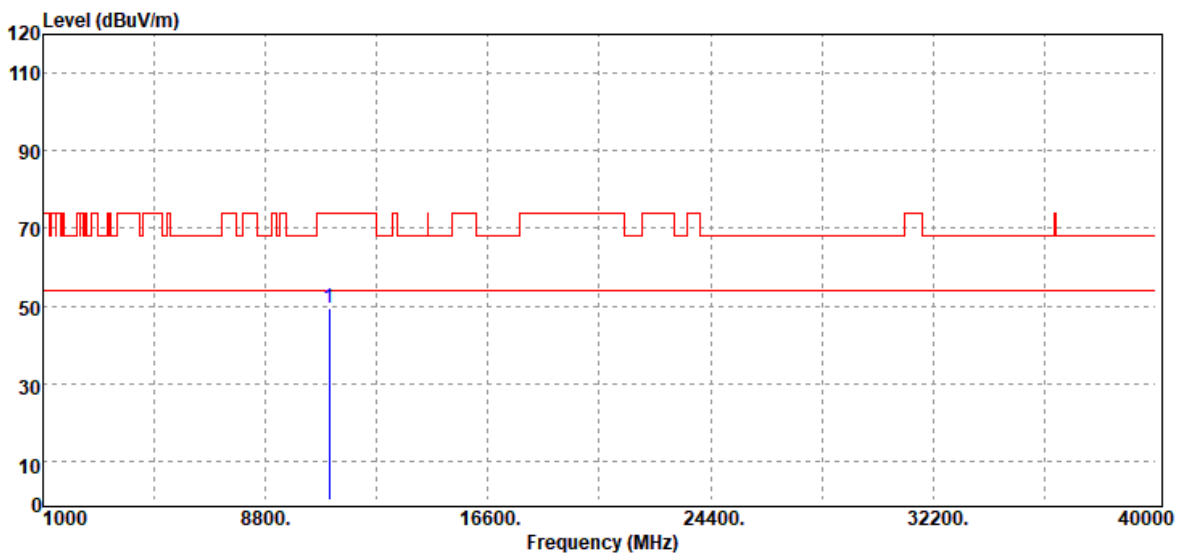

Freq. MHz	Detector Mode PK/QP/AV	Spectrum Reading Level dB μ V	Factor dB	Actual FS dB μ V/m	Limit @3m dB μ V/m	Margin dB
11020.00	Peak	33.37	16.18	49.55	74.00	-24.45
N/A						

Remark:

1. Measuring frequencies from 1 GHz to the 10th harmonic of highest fundamental frequency.
2. For above 1GHz, the EUT peak value was under average limit, therefore the Average value compliance with the average limit

Report No.: T200504W06-RP4

Test Mode	IEEE 802.11n 40 MHz / 5510 MHz	Temp/Hum	23.6(°C)/ 45%RH
Test Item	Harmonic	Test Date	May 14, 2020
Polarize	Horizontal	Test Engineer	Jerry Chang
Detector	Peak		

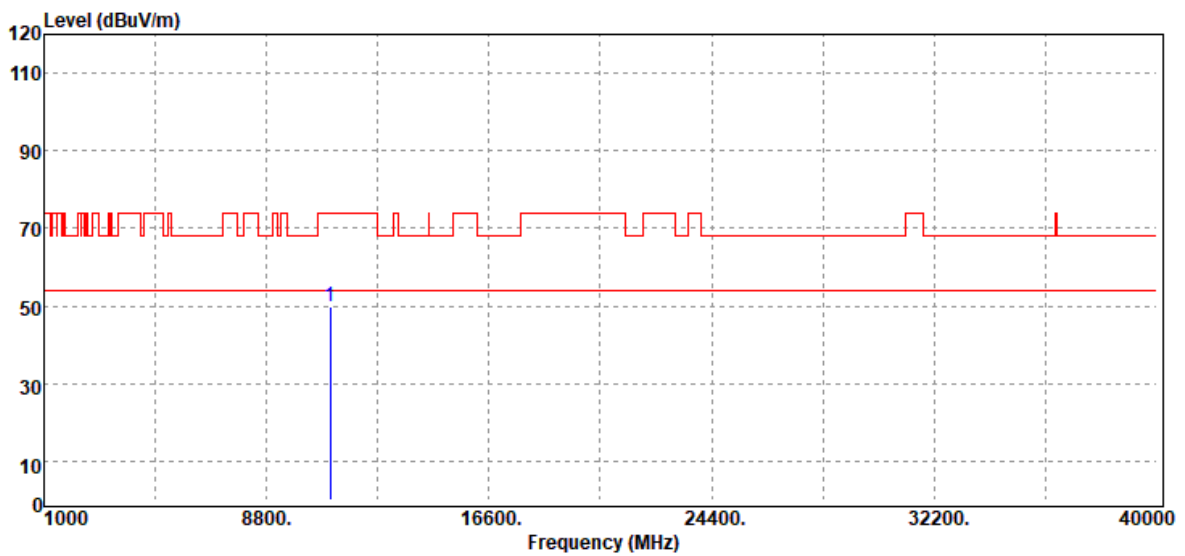

Freq. MHz	Detector Mode PK/QP/AV	Spectrum Reading Level dB μ V	Factor dB	Actual FS dB μ V/m	Limit @3m dB μ V/m	Margin dB
11020.00	Peak	33.47	16.18	49.65	74.00	-24.35
N/A						

Remark:

1. Measuring frequencies from 1 GHz to the 10th harmonic of highest fundamental frequency.
2. For above 1GHz, the EUT peak value was under average limit, therefore the Average value compliance with the average limit

Report No.: T200504W06-RP4

Test Mode	IEEE 802.11n 40 MHz / 5550 MHz	Temp/Hum	23.6(°C)/ 45%RH
Test Item	Harmonic	Test Date	May 14, 2020
Polarize	Vertical	Test Engineer	Jerry Chang
Detector	Peak		

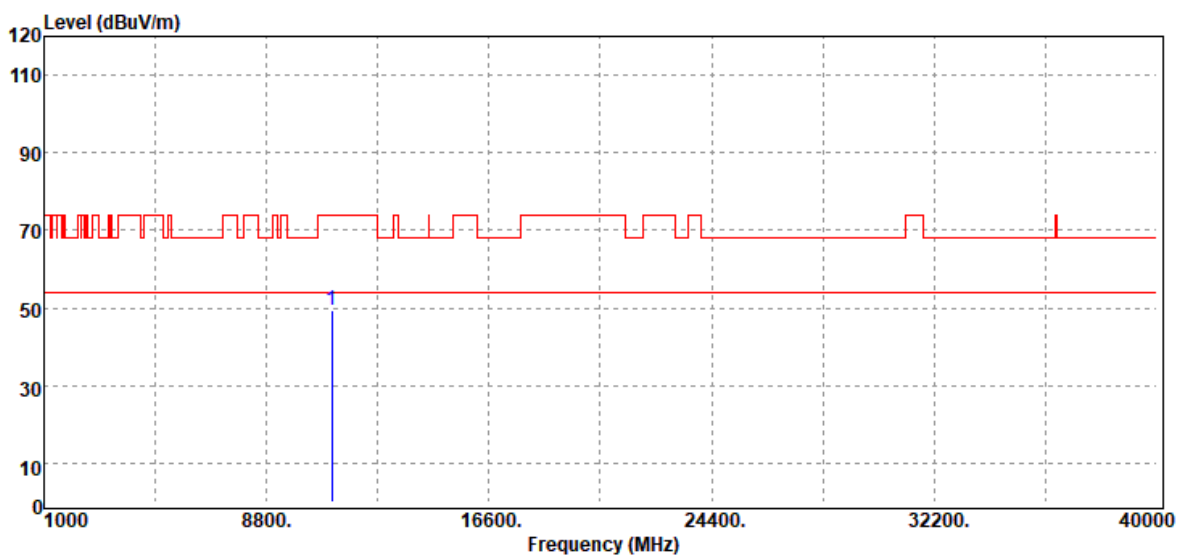

Freq. MHz	Detector Mode PK/QP/AV	Spectrum Reading Level dB μ V	Factor dB	Actual FS dB μ V/m	Limit @3m dB μ V/m	Margin dB
11100.00	Peak	32.67	16.55	49.22	74.00	-24.78
N/A						

Remark:

1. Measuring frequencies from 1 GHz to the 10th harmonic of highest fundamental frequency.
2. For above 1GHz, the EUT peak value was under average limit, therefore the Average value compliance with the average limit

Report No.: T200504W06-RP4

Test Mode	IEEE 802.11n 40 MHz / 5550 MHz	Temp/Hum	23.6(°C)/ 45%RH
Test Item	Harmonic	Test Date	May 14, 2020
Polarize	Horizontal	Test Engineer	Jerry Chang
Detector	Peak		



Freq. MHz	Detector Mode PK/QP/AV	Spectrum Reading Level dB μ V	Factor dB	Actual FS dB μ V/m	Limit @3m dB μ V/m	Margin dB
11100.00	Peak	33.83	16.55	50.38	74.00	-23.62
N/A						

Remark:

1. Measuring frequencies from 1 GHz to the 10th harmonic of highest fundamental frequency.
2. For above 1GHz, the EUT peak value was under average limit, therefore the Average value compliance with the average limit

Report No.: T200504W06-RP4

Test Mode	IEEE 802.11n 40 MHz / 5590 MHz	Temp/Hum	23.6(°C)/ 45%RH
Test Item	Harmonic	Test Date	May 14, 2020
Polarize	Vertical	Test Engineer	Jerry Chang
Detector	Peak		

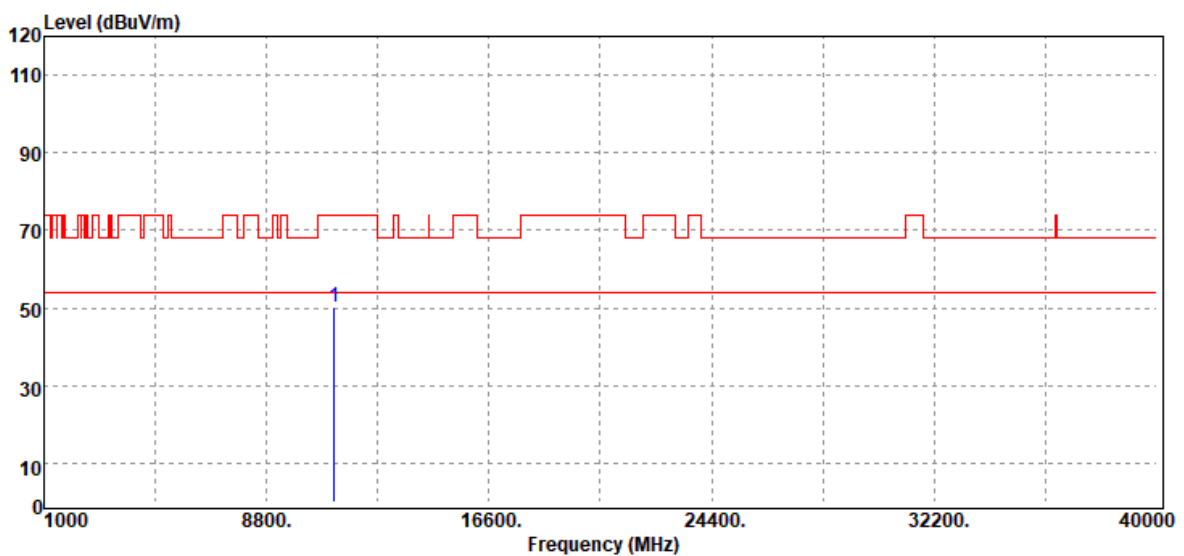

Freq. MHz	Detector Mode PK/QP/AV	Spectrum Reading Level dB μ V	Factor dB	Actual FS dB μ V/m	Limit @3m dB μ V/m	Margin dB
11180.00	Peak	33.67	16.53	50.20	74.00	-23.80
N/A						

Remark:

1. Measuring frequencies from 1 GHz to the 10th harmonic of highest fundamental frequency.
2. For above 1GHz, the EUT peak value was under average limit, therefore the Average value compliance with the average limit

Report No.: T200504W06-RP4

Test Mode	IEEE 802.11n 40 MHz / 5590 MHz	Temp/Hum	23.6(°C)/ 45%RH
Test Item	Harmonic	Test Date	May 14, 2020
Polarize	Horizontal	Test Engineer	Jerry Chang
Detector	Peak		

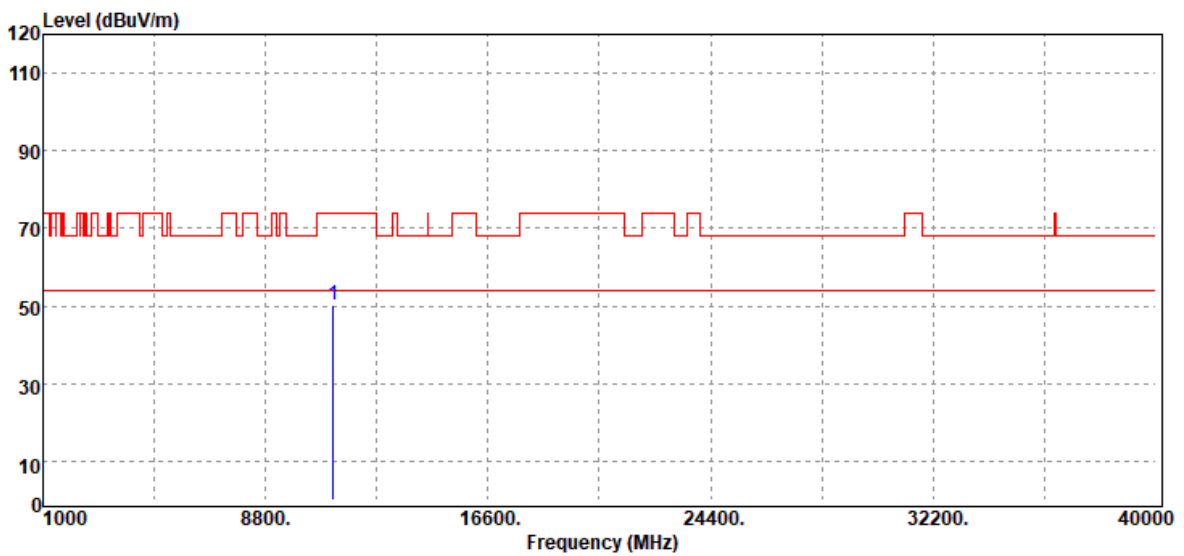

Freq. MHz	Detector Mode PK/QP/AV	Spectrum Reading Level dB μ V	Factor dB	Actual FS dB μ V/m	Limit @3m dB μ V/m	Margin dB
11180.00	Peak	33.85	16.53	50.38	74.00	-23.62
N/A						

Remark:

1. Measuring frequencies from 1 GHz to the 10th harmonic of highest fundamental frequency.
2. For above 1GHz, the EUT peak value was under average limit, therefore the Average value compliance with the average limit

Report No.: T200504W06-RP4

Test Mode	IEEE 802.11n 40 MHz / 5630 MHz	Temp/Hum	23.6(°C)/ 45%RH
Test Item	Harmonic	Test Date	May 14, 2020
Polarize	Vertical	Test Engineer	Jerry Chang
Detector	Peak		

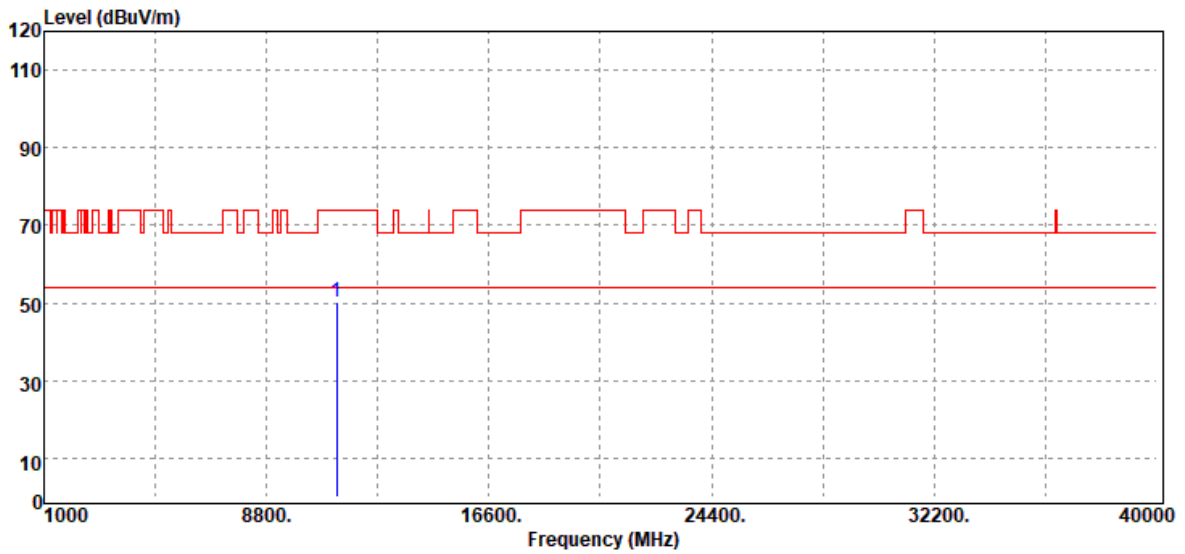

Freq. MHz	Detector Mode PK/QP/AV	Spectrum Reading Level dB μ V	Factor dB	Actual FS dB μ V/m	Limit @3m dB μ V/m	Margin dB
11260.00	Peak	33.81	16.58	50.39	74.00	-23.61
N/A						

Remark:

1. Measuring frequencies from 1 GHz to the 10th harmonic of highest fundamental frequency.
2. For above 1GHz, the EUT peak value was under average limit, therefore the Average value compliance with the average limit

Report No.: T200504W06-RP4

Test Mode	IEEE 802.11n 40 MHz / 5630 MHz	Temp/Hum	23.6(°C)/ 45%RH
Test Item	Harmonic	Test Date	May 14, 2020
Polarize	Horizontal	Test Engineer	Jerry Chang
Detector	Peak		



Freq. MHz	Detector Mode PK/QP/AV	Spectrum Reading Level dB μ V	Factor dB	Actual FS dB μ V/m	Limit @3m dB μ V/m	Margin dB
11260.00	Peak	32.31	16.58	48.89	74.00	-25.11
N/A						

Remark:

1. Measuring frequencies from 1 GHz to the 10th harmonic of highest fundamental frequency.
2. For above 1GHz, the EUT peak value was under average limit, therefore the Average value compliance with the average limit

Report No.: T200504W06-RP4

Test Mode	IEEE 802.11n 40 MHz / 5670 MHz	Temp/Hum	23.6(°C)/ 45%RH
Test Item	Harmonic	Test Date	May 14, 2020
Polarize	Vertical	Test Engineer	Jerry Chang
Detector	Peak		

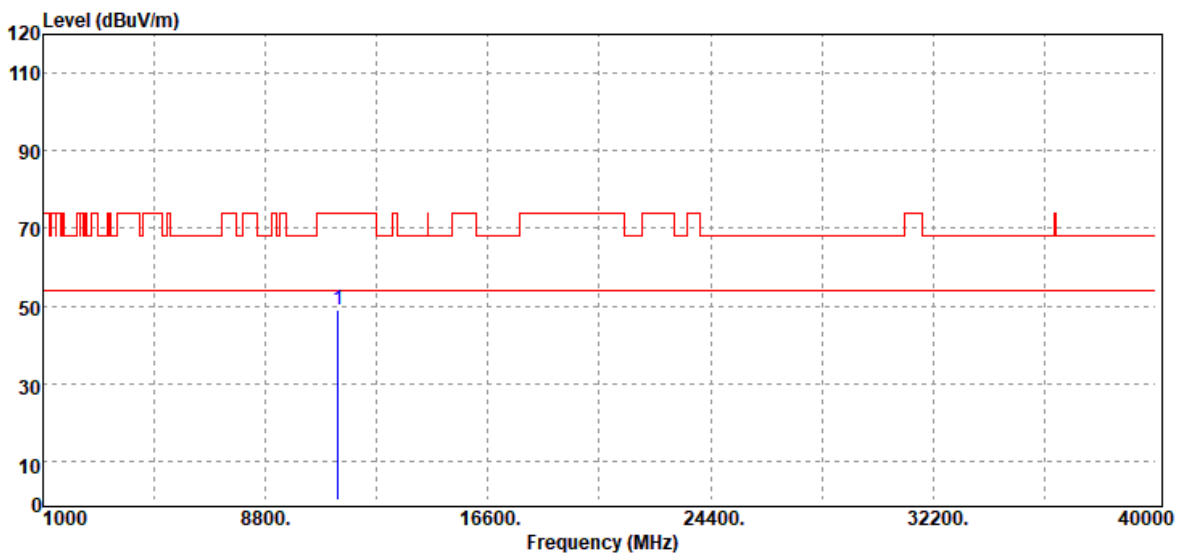

Freq. MHz	Detector Mode PK/QP/AV	Spectrum Reading Level dB μ V	Factor dB	Actual FS dB μ V/m	Limit @3m dB μ V/m	Margin dB
11340.00	Peak	32.61	16.43	49.04	74.00	-24.96
N/A						

Remark:

1. Measuring frequencies from 1 GHz to the 10th harmonic of highest fundamental frequency.
2. For above 1GHz, the EUT peak value was under average limit, therefore the Average value compliance with the average limit

Report No.: T200504W06-RP4

Test Mode	IEEE 802.11n 40 MHz / 5670 MHz	Temp/Hum	23.6(°C)/ 45%RH
Test Item	Harmonic	Test Date	May 14, 2020
Polarize	Horizontal	Test Engineer	Jerry Chang
Detector	Peak		

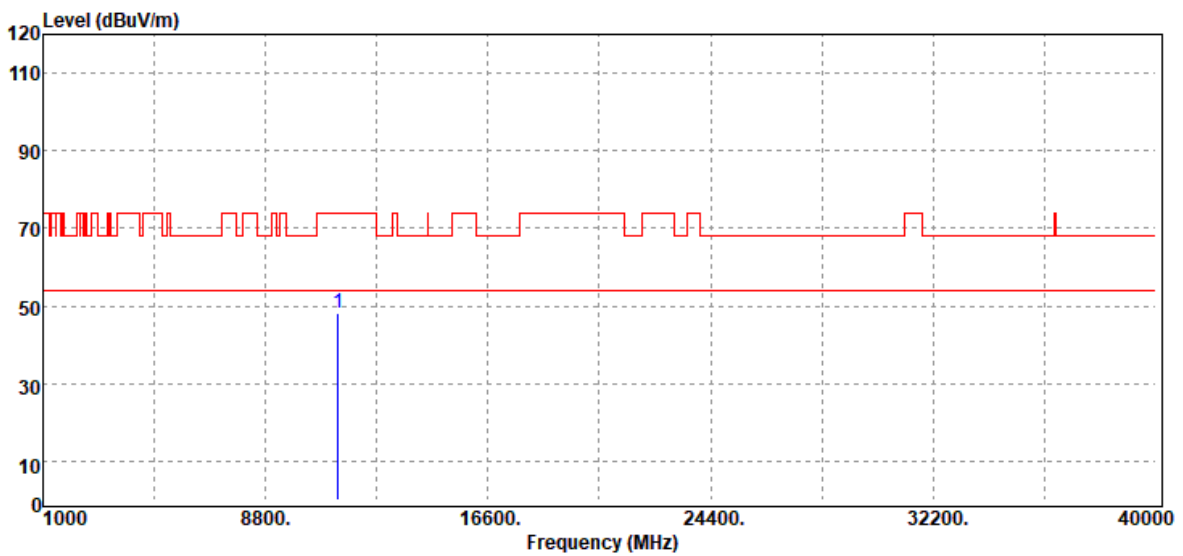

Freq. MHz	Detector Mode PK/QP/AV	Spectrum Reading Level dB μ V	Factor dB	Actual FS dB μ V/m	Limit @3m dB μ V/m	Margin dB
11340.00	Peak	31.69	16.43	48.12	74.00	-25.88
N/A						

Remark:

1. Measuring frequencies from 1 GHz to the 10th harmonic of highest fundamental frequency.
2. For above 1GHz, the EUT peak value was under average limit, therefore the Average value compliance with the average limit

Report No.: T200504W06-RP4

Test Data for UNII-3

Test Mode	IEEE 802.11a / 5745 MHz	Temp/Hum	23.6(°C)/ 45%RH
Test Item	Harmonic	Test Date	May 14, 2020
Polarize	Vertical	Test Engineer	Jerry Chang
Detector	Peak		



Freq. MHz	Detector Mode PK/QP/AV	Spectrum Reading Level dBμV	Factor dB	Actual FS dBμV/m	Limit @3m dBμV/m	Margin dB
11490.00	Peak	33.81	16.01	49.82	74.00	-24.18
N/A						

Remark:

1. Measuring frequencies from 1 GHz to the 10th harmonic of highest fundamental frequency.
2. For above 1GHz, the EUT peak value was under average limit, therefore the Average value compliance with the average limit

Report No.: T200504W06-RP4

Test Mode	IEEE 802.11a / 5745 MHz	Temp/Hum	23.6(°C)/ 45%RH
Test Item	Harmonic	Test Date	May 14, 2020
Polarize	Horizontal	Test Engineer	Jerry Chang
Detector	Peak		



Freq. MHz	Detector Mode PK/QP/AV	Spectrum Reading Level dB μ V	Factor dB	Actual FS dB μ V/m	Limit @3m dB μ V/m	Margin dB
11490.00	Peak	33.28	16.01	49.29	74.00	-24.71
N/A						

Remark:

1. Measuring frequencies from 1 GHz to the 10th harmonic of highest fundamental frequency.
2. For above 1GHz, the EUT peak value was under average limit, therefore the Average value compliance with the average limit

Report No.: T200504W06-RP4

Test Mode	IEEE 802.11a / 5785 MHz	Temp/Hum	23.6(°C)/ 45%RH
Test Item	Harmonic	Test Date	May 14, 2020
Polarize	Vertical	Test Engineer	Jerry Chang
Detector	Peak		

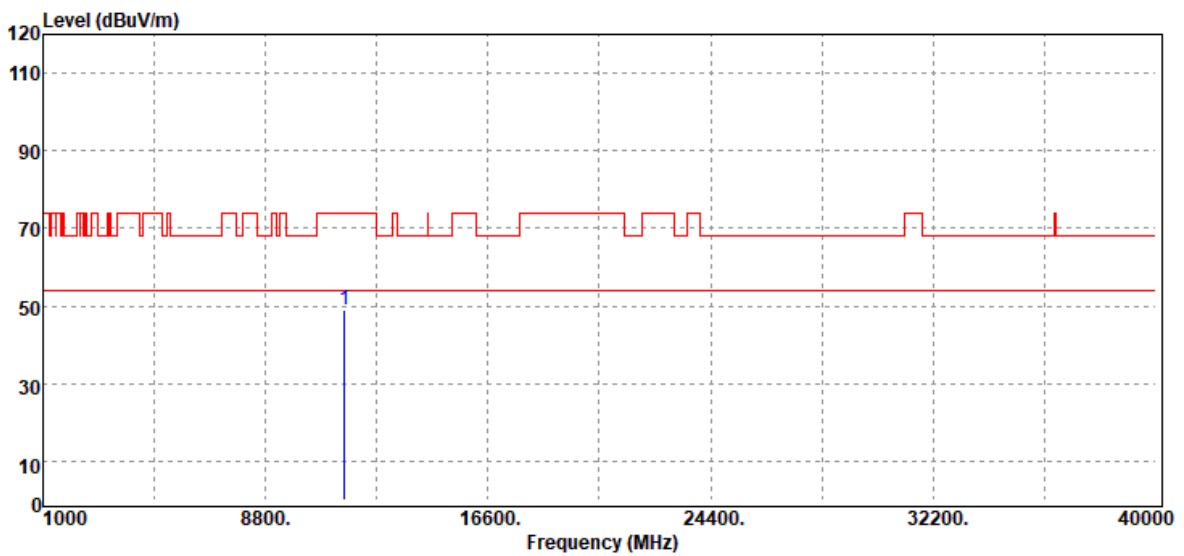

Freq. MHz	Detector Mode PK/QP/AV	Spectrum Reading Level dB μ V	Factor dB	Actual FS dB μ V/m	Limit @3m dB μ V/m	Margin dB
11570.00	Peak	32.89	16.08	48.97	74.00	-25.03
N/A						

Remark:

1. Measuring frequencies from 1 GHz to the 10th harmonic of highest fundamental frequency.
2. For above 1GHz, the EUT peak value was under average limit, therefore the Average value compliance with the average limit

Report No.: T200504W06-RP4

Test Mode	IEEE 802.11a / 5785 MHz	Temp/Hum	23.6(°C)/ 45%RH
Test Item	Harmonic	Test Date	May 14, 2020
Polarize	Horizontal	Test Engineer	Jerry Chang
Detector	Peak		

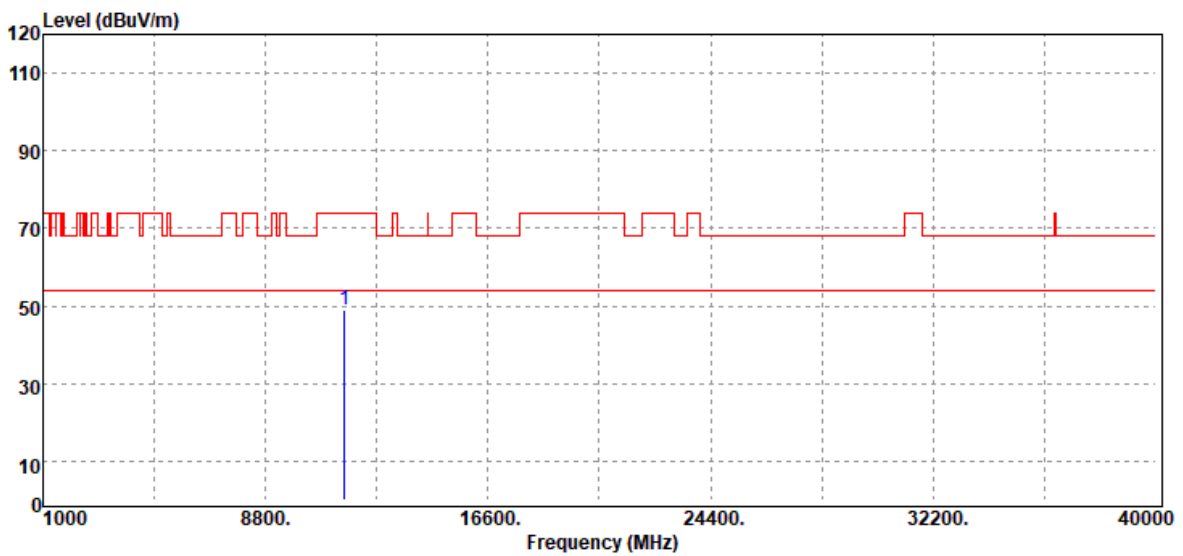

Freq. MHz	Detector Mode PK/QP/AV	Spectrum Reading Level dB μ V	Factor dB	Actual FS dB μ V/m	Limit @3m dB μ V/m	Margin dB
11570.00	Peak	32.88	16.08	48.96	74.00	-25.04
N/A						

Remark:

1. Measuring frequencies from 1 GHz to the 10th harmonic of highest fundamental frequency.
2. For above 1GHz, the EUT peak value was under average limit, therefore the Average value compliance with the average limit

Report No.: T200504W06-RP4

Test Mode	IEEE 802.11a / 5825 MHz	Temp/Hum	23.6(°C)/ 45%RH
Test Item	Harmonic	Test Date	May 14, 2020
Polarize	Vertical	Test Engineer	Jerry Chang
Detector	Peak		

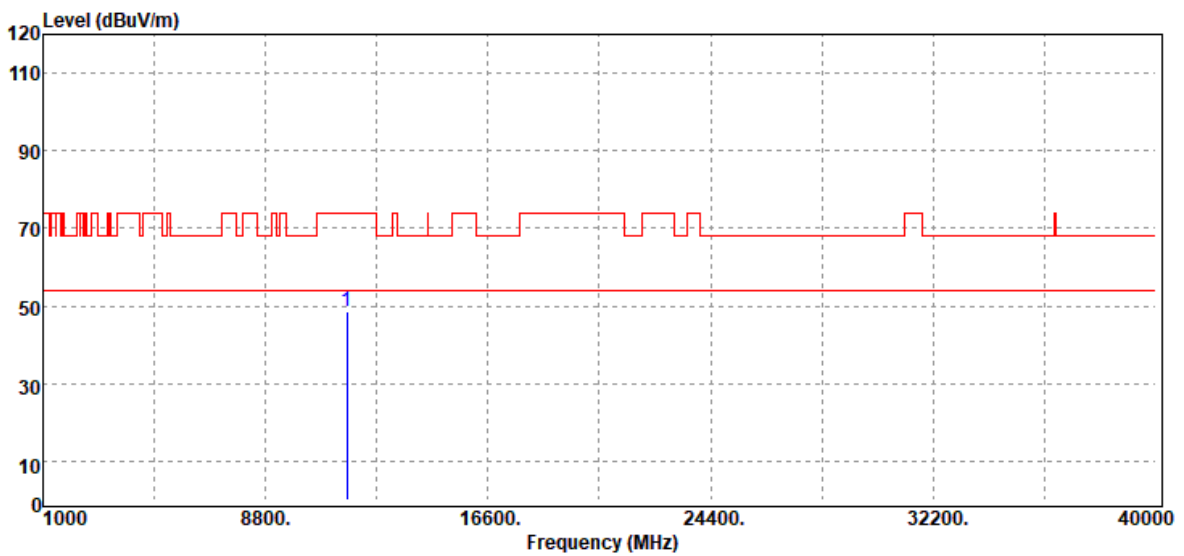

Freq. MHz	Detector Mode PK/QP/AV	Spectrum Reading Level dB μ V	Factor dB	Actual FS dB μ V/m	Limit @3m dB μ V/m	Margin dB
11650.00	Peak	32.71	16.06	48.77	74.00	-25.23
N/A						

Remark:

1. Measuring frequencies from 1 GHz to the 10th harmonic of highest fundamental frequency.
2. For above 1GHz, the EUT peak value was under average limit, therefore the Average value compliance with the average limit

Report No.: T200504W06-RP4

Test Mode	IEEE 802.11a / 5825 MHz	Temp/Hum	23.6(°C)/ 45%RH
Test Item	Harmonic	Test Date	May 14, 2020
Polarize	Horizontal	Test Engineer	Jerry Chang
Detector	Peak		

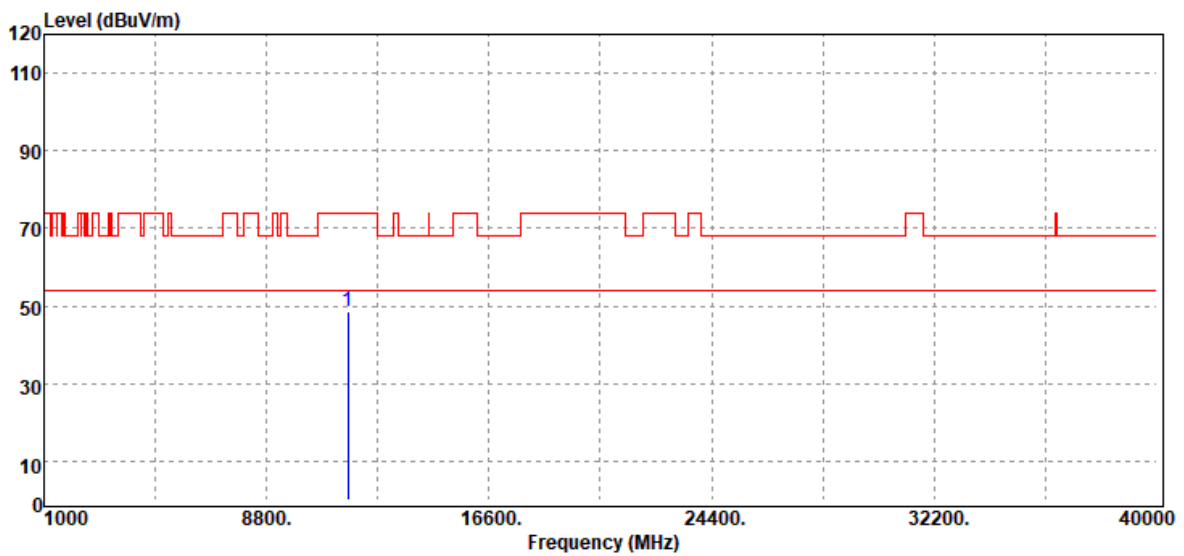

Freq. MHz	Detector Mode PK/QP/AV	Spectrum Reading Level dB μ V	Factor dB	Actual FS dB μ V/m	Limit @3m dB μ V/m	Margin dB
11650.00	Peak	32.67	16.06	48.73	74.00	-25.27
N/A						

Remark:

1. Measuring frequencies from 1 GHz to the 10th harmonic of highest fundamental frequency.
2. For above 1GHz, the EUT peak value was under average limit, therefore the Average value compliance with the average limit

Report No.: T200504W06-RP4

Test Mode	IEEE 802.11n 20 MHz / 5745 MHz	Temp/Hum	23.6(°C)/ 45%RH
Test Item	Harmonic	Test Date	May 14, 2020
Polarize	Vertical	Test Engineer	Jerry Chang
Detector	Peak		

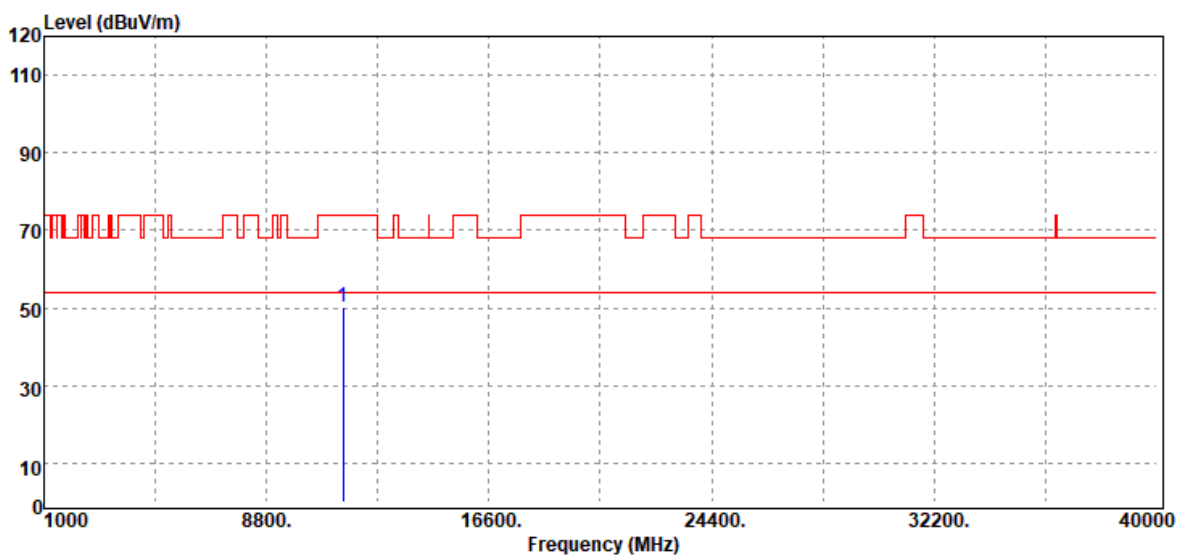

Freq. MHz	Detector Mode PK/QP/AV	Spectrum Reading Level dB μ V	Factor dB	Actual FS dB μ V/m	Limit @3m dB μ V/m	Margin dB
11490.00	Peak	34.41	16.01	50.42	74.00	-23.58
N/A						

Remark:

1. Measuring frequencies from 1 GHz to the 10th harmonic of highest fundamental frequency.
2. For above 1GHz, the EUT peak value was under average limit, therefore the Average value compliance with the average limit

Report No.: T200504W06-RP4

Test Mode	IEEE 802.11n 20 MHz / 5745 MHz	Temp/Hum	23.6(°C)/ 45%RH
Test Item	Harmonic	Test Date	May 14, 2020
Polarize	Horizontal	Test Engineer	Jerry Chang
Detector	Peak		

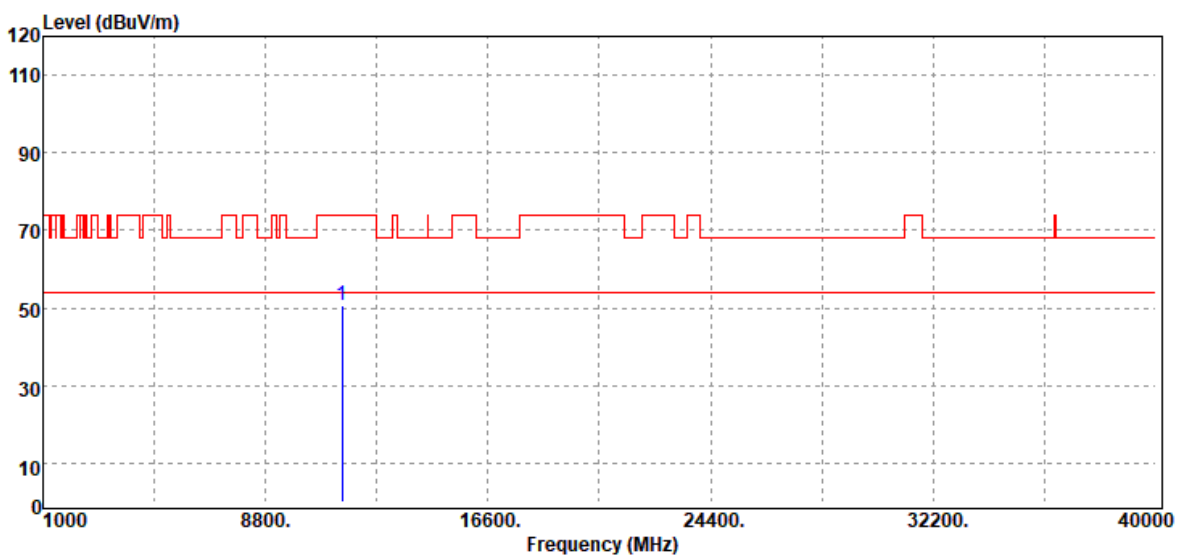

Freq. MHz	Detector Mode PK/QP/AV	Spectrum Reading Level dB μ V	Factor dB	Actual FS dB μ V/m	Limit @3m dB μ V/m	Margin dB
11490.00	Peak	34.45	16.01	50.46	74.00	-23.54
N/A						

Remark:

1. Measuring frequencies from 1 GHz to the 10th harmonic of highest fundamental frequency.
2. For above 1GHz, the EUT peak value was under average limit, therefore the Average value compliance with the average limit

Report No.: T200504W06-RP4

Test Mode	IEEE 802.11n 20 MHz/ 5785 MHz	Temp/Hum	23.6(°C)/ 45%RH
Test Item	Harmonic	Test Date	May 14, 2020
Polarize	Vertical	Test Engineer	Jerry Chang
Detector	Peak		

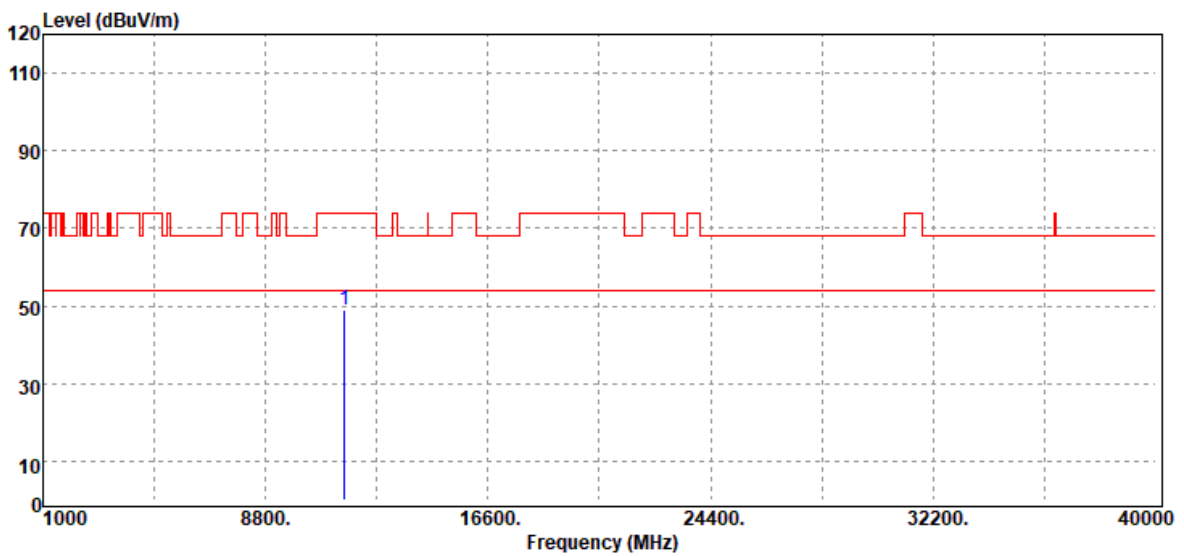

Freq. MHz	Detector Mode PK/QP/AV	Spectrum Reading Level dB μ V	Factor dB	Actual FS dB μ V/m	Limit @3m dB μ V/m	Margin dB
11570.00	Peak	32.76	16.08	48.84	74.00	-25.16
N/A						

Remark:

1. Measuring frequencies from 1 GHz to the 10th harmonic of highest fundamental frequency.
2. For above 1GHz, the EUT peak value was under average limit, therefore the Average value compliance with the average limit

Report No.: T200504W06-RP4

Test Mode	IEEE 802.11n 20 MHz/ 5785 MHz	Temp/Hum	23.6(°C)/ 45%RH
Test Item	Harmonic	Test Date	May 14, 2020
Polarize	Horizontal	Test Engineer	Jerry Chang
Detector	Peak		

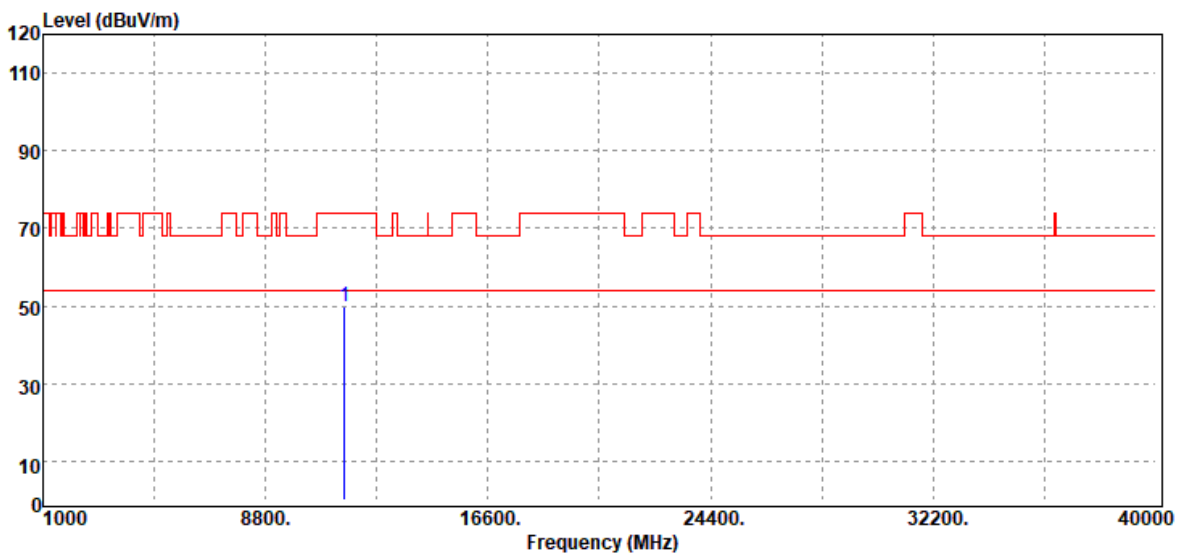

Freq. MHz	Detector Mode PK/QP/AV	Spectrum Reading Level dB μ V	Factor dB	Actual FS dB μ V/m	Limit @3m dB μ V/m	Margin dB
11570.00	Peak	33.92	16.08	50.00	74.00	-24.00
N/A						

Remark:

1. Measuring frequencies from 1 GHz to the 10th harmonic of highest fundamental frequency.
2. For above 1GHz, the EUT peak value was under average limit, therefore the Average value compliance with the average limit

Report No.: T200504W06-RP4

Test Mode	IEEE 802.11n 20 MHz/ 5825 MHz	Temp/Hum	23.6(°C)/ 45%RH
Test Item	Harmonic	Test Date	May 14, 2020
Polarize	Vertical	Test Engineer	Jerry Chang
Detector	Peak		

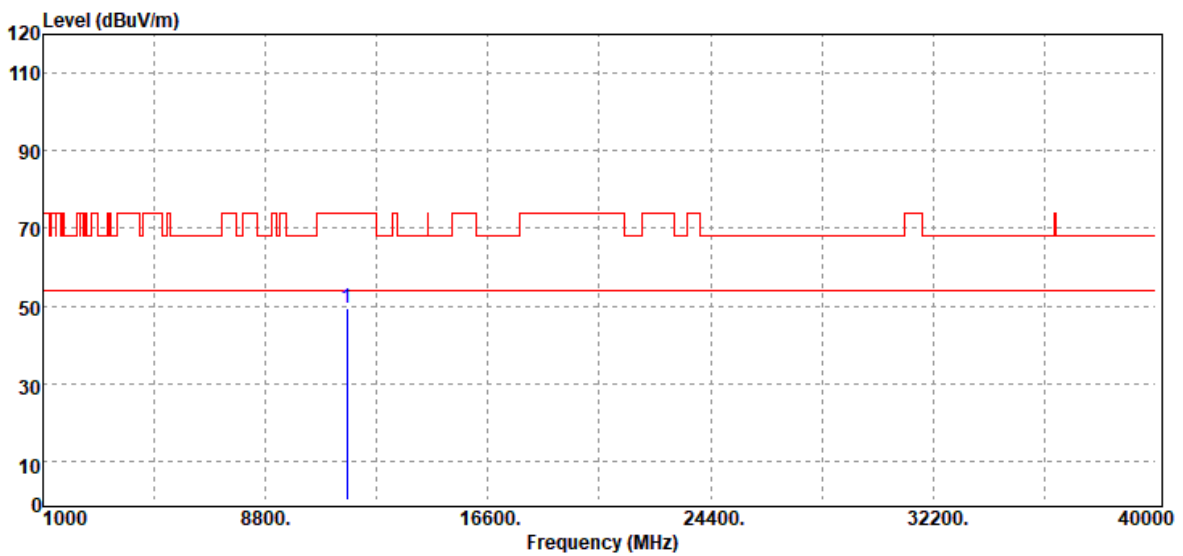

Freq. MHz	Detector Mode PK/QP/AV	Spectrum Reading Level dB μ V	Factor dB	Actual FS dB μ V/m	Limit @3m dB μ V/m	Margin dB
11650.00	Peak	33.15	16.06	49.21	74.00	-24.79
N/A						

Remark:

1. Measuring frequencies from 1 GHz to the 10th harmonic of highest fundamental frequency.
2. For above 1GHz, the EUT peak value was under average limit, therefore the Average value compliance with the average limit

Report No.: T200504W06-RP4

Test Mode	IEEE 802.11n 20 MHz/ 5825 MHz	Temp/Hum	23.6(°C)/ 45%RH
Test Item	Harmonic	Test Date	May 14, 2020
Polarize	Horizontal	Test Engineer	Jerry Chang
Detector	Peak		



Freq. MHz	Detector Mode PK/QP/AV	Spectrum Reading Level dB μ V	Factor dB	Actual FS dB μ V/m	Limit @3m dB μ V/m	Margin dB
11650.00	Peak	32.69	16.06	48.75	74.00	-25.25
N/A						

Remark:

1. Measuring frequencies from 1 GHz to the 10th harmonic of highest fundamental frequency.
2. For above 1GHz, the EUT peak value was under average limit, therefore the Average value compliance with the average limit

Report No.: T200504W06-RP4

Test Mode	IEEE 802.11n 40 MHz/ 5755 MHz	Temp/Hum	23.6(°C)/ 45%RH
Test Item	Harmonic	Test Date	May 14, 2020
Polarize	Vertical	Test Engineer	Jerry Chang
Detector	Peak		



Freq. MHz	Detector Mode PK/QP/AV	Spectrum Reading Level dB μ V	Factor dB	Actual FS dB μ V/m	Limit @3m dB μ V/m	Margin dB
11510.00	Peak	32.59	16.01	48.60	74.00	-25.40
N/A						

Remark:

1. Measuring frequencies from 1 GHz to the 10th harmonic of highest fundamental frequency.
2. For above 1GHz, the EUT peak value was under average limit, therefore the Average value compliance with the average limit

Report No.: T200504W06-RP4

Test Mode	IEEE 802.11n 40 MHz/ 5755 MHz	Temp/Hum	23.6(°C)/ 45%RH
Test Item	Harmonic	Test Date	May 14, 2020
Polarize	Horizontal	Test Engineer	Jerry Chang
Detector	Peak		



Freq. MHz	Detector Mode PK/QP/AV	Spectrum Reading Level dB μ V	Factor dB	Actual FS dB μ V/m	Limit @3m dB μ V/m	Margin dB
11510.00	Peak	32.74	16.01	48.75	74.00	-25.25
N/A						

Remark:

1. Measuring frequencies from 1 GHz to the 10th harmonic of highest fundamental frequency.
2. For above 1GHz, the EUT peak value was under average limit, therefore the Average value compliance with the average limit

Report No.: T200504W06-RP4

Test Mode	IEEE 802.11n 40 MHz/ 5795 MHz	Temp/Hum	23.6(°C)/ 45%RH
Test Item	Harmonic	Test Date	May 14, 2020
Polarize	Vertical	Test Engineer	Jerry Chang
Detector	Peak		



Freq. MHz	Detector Mode PK/QP/AV	Spectrum Reading Level dB μ V	Factor dB	Actual FS dB μ V/m	Limit @3m dB μ V/m	Margin dB
11590.00	Peak	32.67	16.02	48.69	74.00	-25.31
N/A						

Remark:

1. Measuring frequencies from 1 GHz to the 10th harmonic of highest fundamental frequency.
2. For above 1GHz, the EUT peak value was under average limit, therefore the Average value compliance with the average limit

Report No.: T200504W06-RP4

Test Mode	IEEE 802.11n 40 MHz/ 5795 MHz	Temp/Hum	23.6(°C)/ 45%RH
Test Item	Harmonic	Test Date	May 14, 2020
Polarize	Horizontal	Test Engineer	Jerry Chang
Detector	Peak		



Freq. MHz	Detector Mode PK/QP/AV	Spectrum Reading Level dB μ V	Factor dB	Actual FS dB μ V/m	Limit @3m dB μ V/m	Margin dB
11590.00	Peak	31.57	16.02	47.59	74.00	-26.41
N/A						

Remark:

1. Measuring frequencies from 1 GHz to the 10th harmonic of highest fundamental frequency.
2. For above 1GHz, the EUT peak value was under average limit, therefore the Average value compliance with the average limit

4.6 FREQUENCY STABILITY

4.6.1 Test Limit

According to RSS-Gen(6.11) manufacturers of U-NII devices are responsible for ensuring frequency stability such that an emission is maintained within the band of operation under all conditions of normal operation as specified in the operational description.

4.6.2 Test Procedure

The equipment under test was connected to an external AC or DC power supply and input rated voltage. RF output was connected to a frequency counter or spectrum analyzer via feed through attenuators. The EUT was placed inside the temperature chamber. Set the spectrum analyzer RBW low enough to obtain the desired frequency resolution and measure EUT 25°C operating frequency as reference frequency. Turn EUT off and set the chamber temperature to 0°C. After the temperature stabilized for approximately 30 minutes recorded the frequency. Repeat step measure with 10°C increased per stage until the highest temperature of +40°C reached.

4.6.3 Test Setup

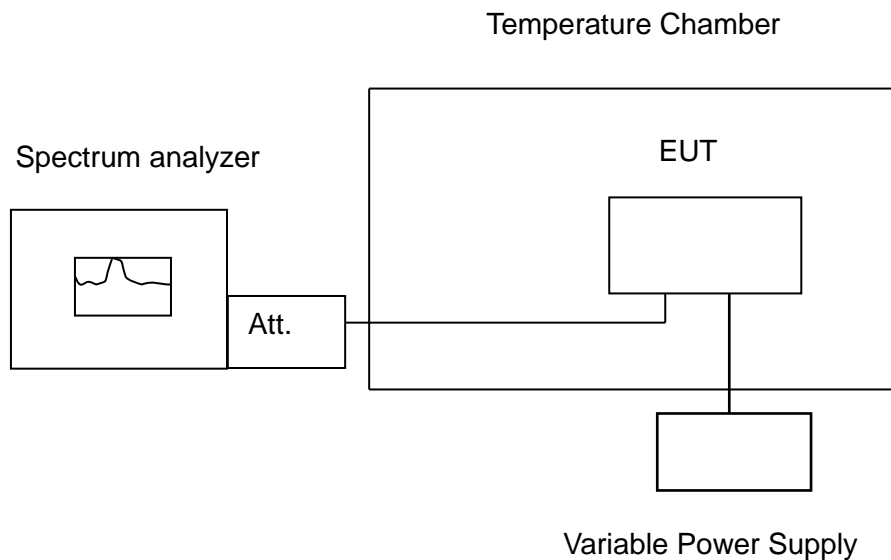

Report No.: T200504W06-RP4

4.6.4 Test Result

Temp. (°C)	Voltage (V)	Measured Frequency	5180				(MHz)	Limit				Result
			Time (min)					20ppm				
Operating Frequency:		0 min	2 min	5 min	10 min	0 min	2 min	5 min	10 min			
40	12	5179.99884	5179.99884	5179.99884	5179.99884	-0.2240	-0.2241	-0.2241	-0.2240	Pass		
30	12	5179.99884	5179.99884	5179.99884	5179.99884	-0.2240	-0.2240	-0.2240	-0.2240	Pass		
20	12	5179.99884	5179.99884	5179.99884	5179.99884	-0.2240	-0.2241	-0.2241	-0.2241	Pass		
10	12	5179.99914	5179.99910	5179.99914	5179.99914	-0.1665	-0.1737	-0.1665	-0.1665	Pass		
0	12	5179.99914	5179.99937	5179.99914	5179.99914	-0.1666	-0.1216	-0.1666	-0.1666	Pass		

Temp. (°C)	Voltage (V)	Measured Frequency	5180				(MHz)	Limit				Result
			Time (min)					20ppm				
Operating Frequency:		0 min	2 min	5 min	10 min	0 min	2 min	5 min	10 min			
25	10.8	5179.99854	5179.99854	5179.99854	5179.99854	-0.2815	-0.2815	-0.2817	-0.2817	Pass		
25	12	5179.99854	5179.99854	5179.99854	5179.99854	-0.2817	-0.2817	-0.2817	-0.2818	Pass		
25	13.2	5179.99854	5179.99854	5179.99854	5179.99854	-0.2818	-0.2818	-0.2817	-0.2816	Pass		

Temp. (°C)	Voltage (V)	Measured Frequency	5260				(MHz)	Limit				Result
			Time (min)					20ppm				
Operating Frequency:		0 min	2 min	5 min	10 min	0 min	2 min	5 min	10 min			
40	12	5260.00521	5260.00522	5260.00523	5260.00524	0.9905	0.9924	0.9943	0.9962	Pass		
30	12	5260.00520	5260.00525	5260.00526	5260.00524	0.9886	0.9981	1.0000	0.9962	Pass		
20	12	5260.01606	5260.01607	5260.01608	5260.01606	3.0532	3.0551	3.0570	3.0532	Pass		
10	12	5260.02084	5260.02084	5260.02084	5260.02089	3.9620	3.9620	3.9620	3.9715	Pass		
0	12	5260.02301	5260.02302	5260.02303	5260.02301	4.3745	4.3764	4.3783	4.3745	Pass		

Temp. (°C)	Voltage (V)	Measured Frequency	5260				(MHz)	Limit				Result
			Time (min)					20ppm				
Operating Frequency:		0 min	2 min	5 min	10 min	0 min	2 min	5 min	10 min			
25	10.8	5260.04132	5260.01431	5260.01433	5260.01433	7.8555	2.7205	2.7243	2.7243	Pass		
25	12	5260.01476	5260.01476	5260.01477	5260.01478	2.8061	2.8061	2.8080	2.8099	Pass		
25	13.2	5260.01561	5260.01562	5260.01563	5260.01520	2.9677	2.9696	2.9715	2.8897	Pass		

Report No.: T200504W06-RP4

Temp. (°C)	Voltage (V)	Measured Frequency	5500				Limit				Result
			Time (min)				20ppm				
Operating Frequency:		0 min	2 min	5 min	10 min	0 min	2 min	5 min	10 min		
40	12	5499.99137	5499.99138	5499.99132	5499.99131	-1.5691	-1.5673	-1.5782	-1.5800	Pass	
30	12	5499.99135	5499.99136	5499.99137	5499.99136	-1.5727	-1.5709	-1.5691	-1.5709	Pass	
20	12	5499.99134	5499.99130	5499.99130	5499.99870	-1.5745	-1.5818	-1.5818	-0.2364	Pass	
10	12	5499.99137	5499.99870	5499.99137	5499.99138	-1.5691	-0.2364	-1.5691	-1.5673	Pass	
0	12	5499.99136	5499.99134	5499.99136	5499.99870	-1.5709	-1.5745	-1.5709	-0.2364	Pass	

Temp. (°C)	Voltage (V)	Measured Frequency	5500				Limit				Result
			Time (min)				20ppm				
Operating Frequency:		0 min	2 min	5 min	10 min	0 min	2 min	5 min	10 min		
25	10.8	5499.99566	5499.99606	5499.99653	5499.99696	-0.7891	-0.7164	-0.6309	-0.5527	Pass	
25	12	5499.99783	5499.99826	5499.99826	5499.99783	-0.3945	-0.3164	-0.3164	-0.3945	Pass	
25	13.2	5499.99870	5499.99826	5499.99870	5499.99570	-0.2364	-0.3164	-0.2364	-0.7818	Pass	

Temp. (°C)	Voltage (V)	Measured Frequency	5745				Limit				Result
			Time (min)				20ppm				
Operating Frequency:		0 min	2 min	5 min	10 min	0 min	2 min	5 min	10 min		
40	12	5744.99864	5744.99868	5744.99867	5744.99865	-0.2367	-0.2298	-0.2315	-0.2350	Pass	
30	12	5744.99867	5744.99869	5744.99868	5744.99869	-0.2315	-0.2280	-0.2298	-0.2280	Pass	
20	12	5744.99870	5744.99873	5744.99874	5744.99873	-0.2263	-0.2211	-0.2193	-0.2211	Pass	
10	12	5744.99873	5744.99872	5744.99871	5744.99870	-0.2211	-0.2228	-0.2245	-0.2263	Pass	
0	12	5744.99869	5744.99868	5744.99867	5744.99866	-0.2280	-0.2298	-0.2315	-0.2332	Pass	

Temp. (°C)	Voltage (V)	Measured Frequency	5745				Limit				Result
			Time (min)				20ppm				
Operating Frequency:		0 min	2 min	5 min	10 min	0 min	2 min	5 min	10 min		
25	10.8	5744.99801	5744.99812	5744.99802	5744.99804	-0.3464	-0.3272	-0.3446	-0.3412	Pass	
25	12	5744.99802	5744.99811	5744.99803	5744.99805	-0.3446	-0.3290	-0.3429	-0.3394	Pass	
25	13.2	5744.99806	5744.99807	5744.99806	5744.99807	-0.3377	-0.3359	-0.3377	-0.3359	Pass	

- End of Test Report -