

# Wacom Digitizer Implementation Guide

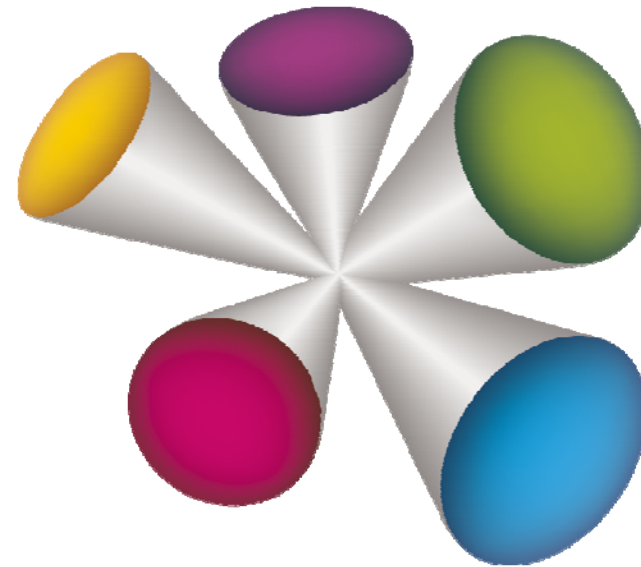

Component Business Division  
Wacom Co., Ltd.

# Contents

1. Principle of Wacom EMR
2. General Specification
3. Structure
4. Digitizer Lineup
5. Display Lineup
6. Customizing Digitizer
7. System Designing (EM noise)
8. System Designing2 (metal parts)
9. System Calibration
10. Driver

# 1. Principle of Wacom EMR

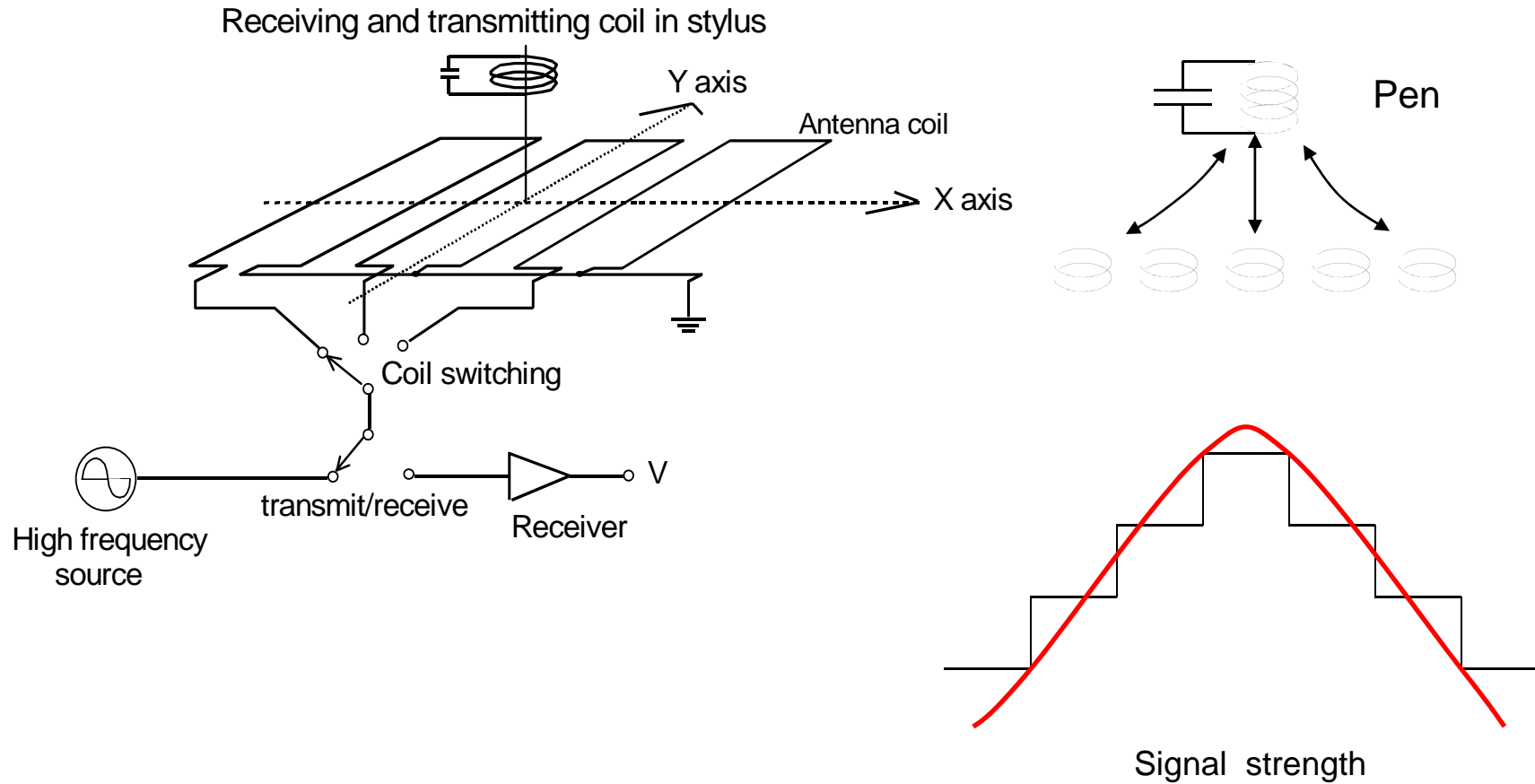

# 2. General Specification

- **Wacom Digitizer Unit**

Technology	EMR (Electro-Magnetic Resonance)
Active Area	263.12 * 165.2 mm for SU5E-12W16AS-00X
Resolution	0.01mm (2540 ppi)
Coordinate Accuracy	±0.4mm (see Note 1 and 2)
Coordinate Deviation When Tilting Pen	±3mm (tilted ±50° from vertical) (see Note 3)
Detectable Pen tilt	Up to 50° from vertical
Detectable Height	4 to 14mm above the Sensor Board (see Note 1)
Position Report Rate	133 pps
Pressure Resolution	256 levels @ full scale
Power Consumption	35mA (max.70mA) @133pps

- Note 1: The digitizer sensor unit and pen only, at ordinary temperature.
- Note 2: The pen held vertically at 7mm high from sensor board.
- Note 3: The pen held in the center of the active area.

# 3-1. Structure

- EMR digitizer be inserted under the LCD

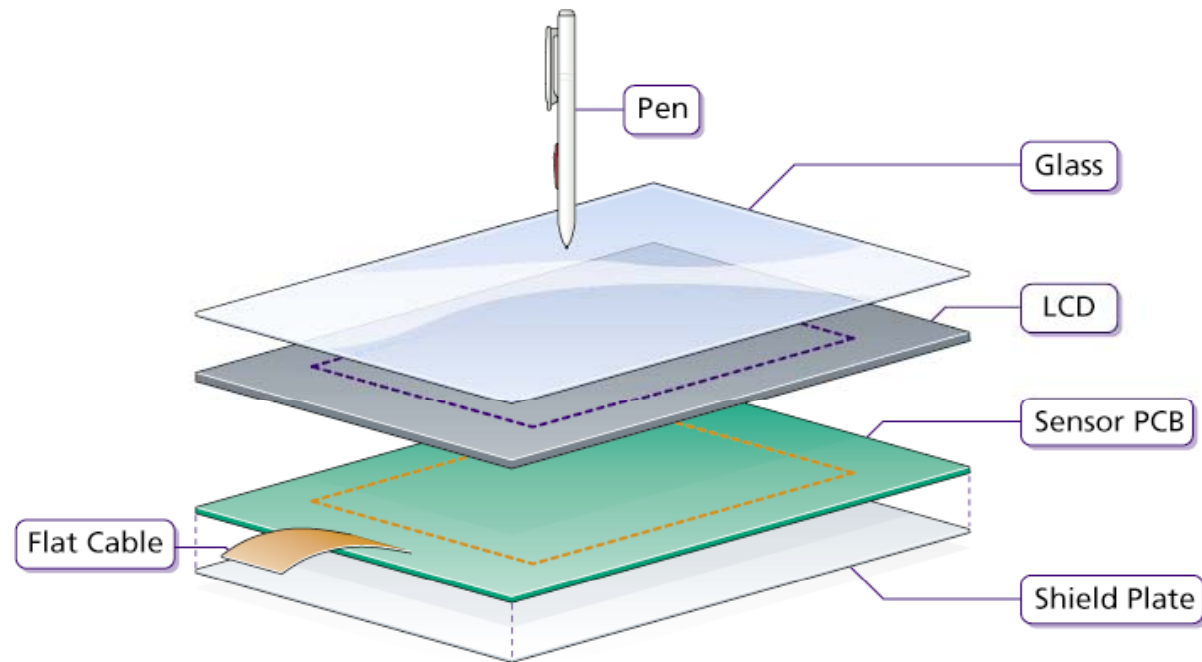

## 3-2. Structure

- EMR digitizer be inserted under the LCD

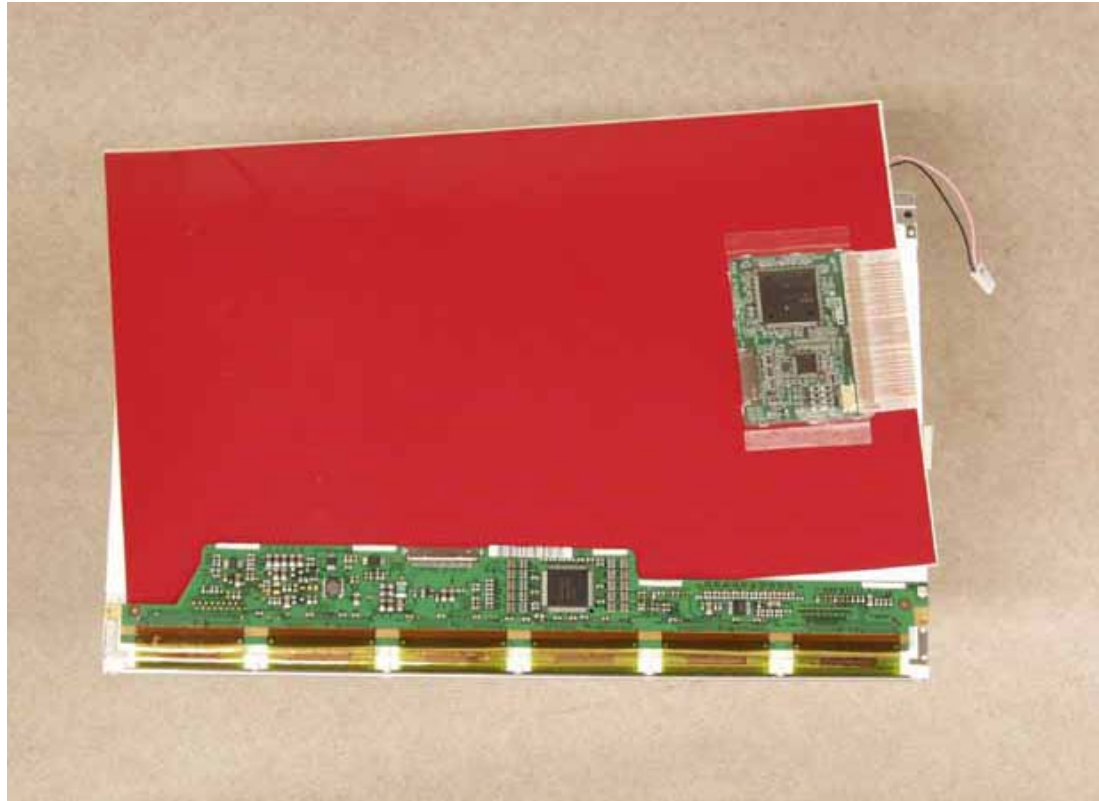

# 4-1. Digitizer Lineup

- Sensor : G4 ... glass epoxy sensor  
G4.5 ... glass epoxy sensor  
G5 ... PET film or FPC (Polyimide)

G4/G4.5



G5

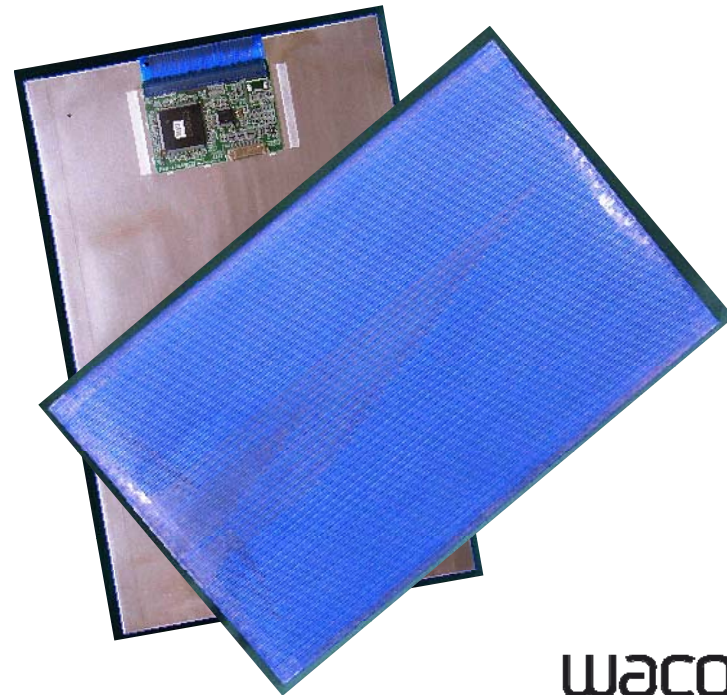

# 4-2. Digitizer Lineup

- G5 sensor

<Front View>

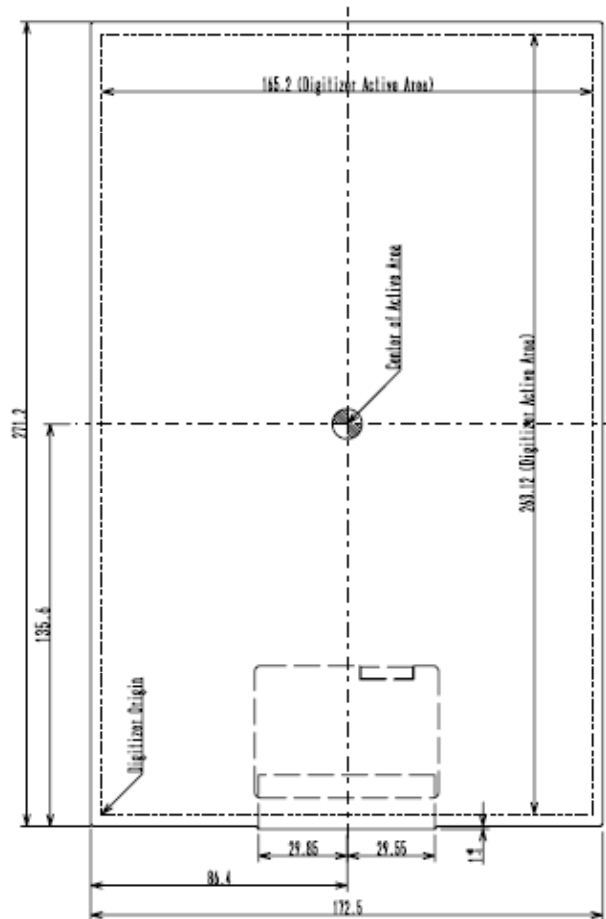

< Side and Rear View >

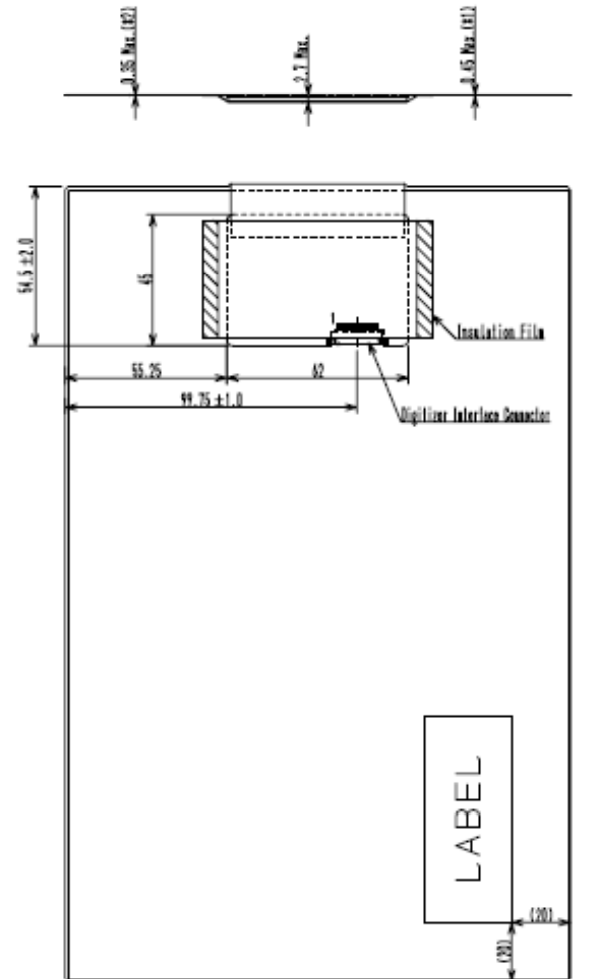



# 4-3. Digitizer Line up

- Technology :
  - EMR only
  - Resistive-DualTouch··· sensor + Resistive Touch screen interface
  - Capacitive-DualTouch··· sensor + Capacitive Touch screen interface

## EMR only

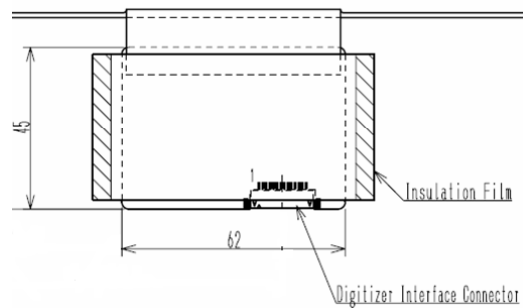

## R-Dual

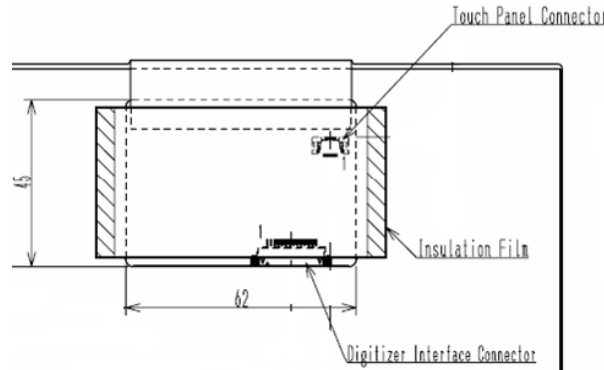

## C-Dual

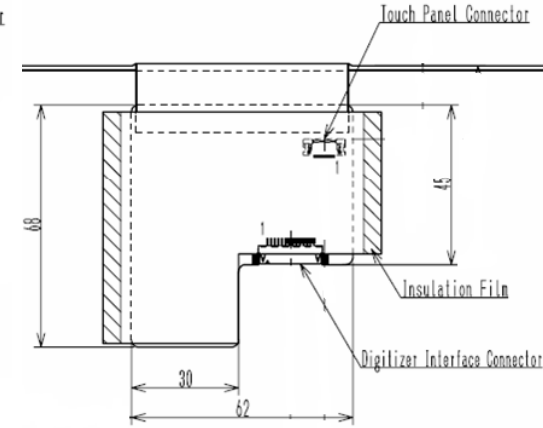

# 4-4. Digitizer Lineup

- Interface : UART, USB

## Signal assignment (UART)

Pin	NAME	IN/OUT	FUNCTION
1	FWE	I	Flash ROM Compulsory Rewrite
2	PWS1	O	Auxiliary Port1
3	PWS2	O	Auxiliary Port2
4	PWS3	O	Auxiliary Port3
5	PWS4	O	Auxiliary Port4
6	PDCT	O	Pen Detect Signal
7	DSR	I	Data Set Ready Signal
8	CTS	I	Clear To Send Signal
9	TxD	O	Serial Data Output Signal
10	RxD	I	Serial Data Input Signal
11	SLP	I	Sleep Signal
12	RES	I	Reset
13	Vcc		Power Suply (3.3 Volt)
14	GND		Ground

## Signal assignment (USB)

Pin	NAME	IN/OUT	FUNCTION
1	FWE	I	Flash ROM Compulsory Rewrite
2	USB GND		USB Ground
3	D+	I/O	USB Data +
4	D-	I/O	USB Data -
5	USB SET	I	USB Setting
6	PDCT	O	Pen Detect Signal
7	P0	I	No Function
8	P1	I	No Function
9	P2	I	No Function
10	P3	I	No Function
11	STOP	I	Stop Signal
12	RES	I	Reset Signal
13	Vcc		Power Supply (3.3 Volt)
14	GND		Ground

# 4-5. Digitizer Lineup

part number	diagonal size of tablet active area	outer dimensions(mm) L×W×t	active area(mm)	total thickness	mass(g)	interface
SU5E-06S01AS-00X	6.0"	138.0×104.0 t=0.35	127.5×94.0	2.7	TBD	UART
SU-039-X00	8.4"	190.5×140.0 t=0.6	172.4×129.8	2.5	46	UART
SU5E-09S01AS-00X	9.7"	214.8×151.4 t=0.35	204.8×141.5	2.7	26	UART
SU4R-10S10PU-00X	10.4"	231.0×170.8 t=0.6	212.4×159.8	2.9	TBD	USB
SU-1201E-00X	12.1"	262.7×195.0 t=0.6	247.8×186.3	2.7	87	UART
SU5R-12S02AU-00X	12.1"	259.1×196.0 t=0.35	247.8×186.3	2.7	TBD	USB
SU5R-12W04AU-00X	12.1" wide	271.2×172.5 t=0.35	263.1×165.2	2.7	36	USB
SU-13W02E-00A	13.3" wide	297.0×190.0 t=0.6	288.1×180.8	2.9	92	USB
SU5E-13W01AS-00X	13.3" wide	296.1×188.8 t=0.35	288.1×180.8	2.7	43	UART
SU-14W07E-00X	14.0" wide	326.2×194.2 t=0.6	307.3×185.2	3.0	103	UART

# 5. Display Lineup

- LCD---Kangaroo type

LCD Company	Part Number	Size	Resolution
TMD	LTD121KCAV	12.1	XGA
TMD	LTD133KX2S	13.3W	WXGA
Hydis	HV121X03-100	12.1	XGA
Hydis	HV121P01-100	12.1	SXGA+
Hydis	HV121WX4-100	12.1W	WXGA
Hydis	HV121WX5-100	12.1W	WXGA
Hydis	HV121WX6-100	12.1W	WXGA
Hydis	HV121WX1	12.1W	WXGA
Hydis	HT12X21		
Hydis	HV104X01-100	10.4	XGA
AUO		14.1	XGA
CMO		14.1	XGA
NEC			
Samsung			
Sharp			

- E-ink display

Size	Model Number	Resolution
5"	ED050SC1	800 x 600
6"	ED060SC3	800 x 600
8"	ED080XC1	1024 x 768
9.7"	ED097OC1	1200 x 825

# 6-1. Customizing Digitizer

- **Condition for digitizer customization**
  1. Minimum Volume: 30K/ year
  2. There will be NRE and Tooling Cost



# 6-2. Customizing Digitizer

- **Sensor Board Design**

1. Must be square shape



2. Must be flat



3. Non-active area must be at least 4mm at each side

— outline  
- - - active area



# 6-3. Customizing Digitizer

- **Sensor Board Design (continued)**
  4. Digitizer active area needs at least 1mm buffer from LCD active area at each side

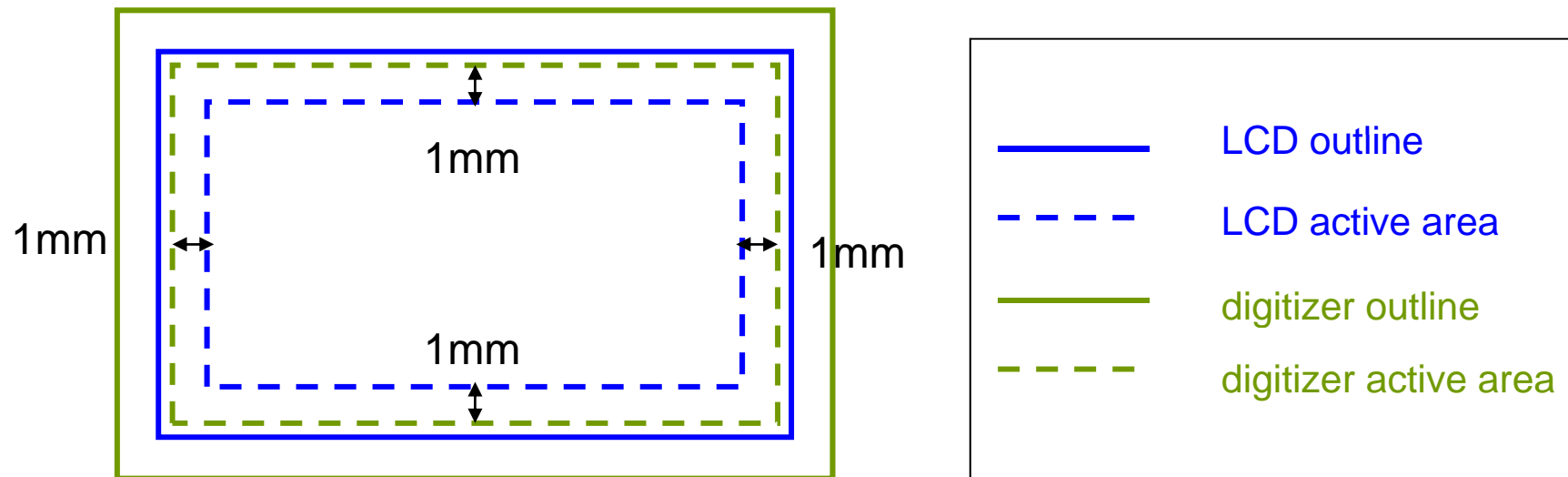

# 6-4. Customizing Digitizer

- **Baby Board Design**
  - Only standard design available.
- **Interface connector**
  - Connector on digitizer: DF19L-14P-1H (HIROSE) or equivalent
  - Counterpart connector: DF19-14S-1S, DF19G-14S-1C (HIROSE) or equivalent



# 6-5. Customizing Digitizer

- Development Schedule

No.	Step	Lead Time
1	Confirm custom design requirement	
2	Release of tentative shipping specification	At the same time as ES sample shipment
3	ES sample shipment *handmade sample with default firmware	8-10 weeks
4	Customer confirmation of shipping specification	
5	System calibration	2 weeks
6	Customer approval of ES sample	
7	CS sample shipment *tooled sample with final calibrated firmware	8-10 weeks
8	Release of final shipping specification	At the same time as CS sample shipment
8	Customer approval of MP (including shipping specification, FW and CS sample)	
9	MP shipment	8-10 weeks

Note: Lead time stated here is only reference and may change depending on digitizer design. Please confirm the final development schedule with Wacom sales.

# 7-1. System Designing

## Prevention of EM noise problem

Some transformers or coils in the power unit generates EM noise.

To prevent this

- Use transformers or coils that won't allow magnetic flux leakage.
- Place them underneath the shield or in a distance as much as possible from the sensor board.
- Position them so that EM noise flux did not across the sensor board.

EM noise source

- Inverter of LCD back light
- DC to DC converter in power circuit

# 7-2. System Designing

## EM Noise Countermeasure

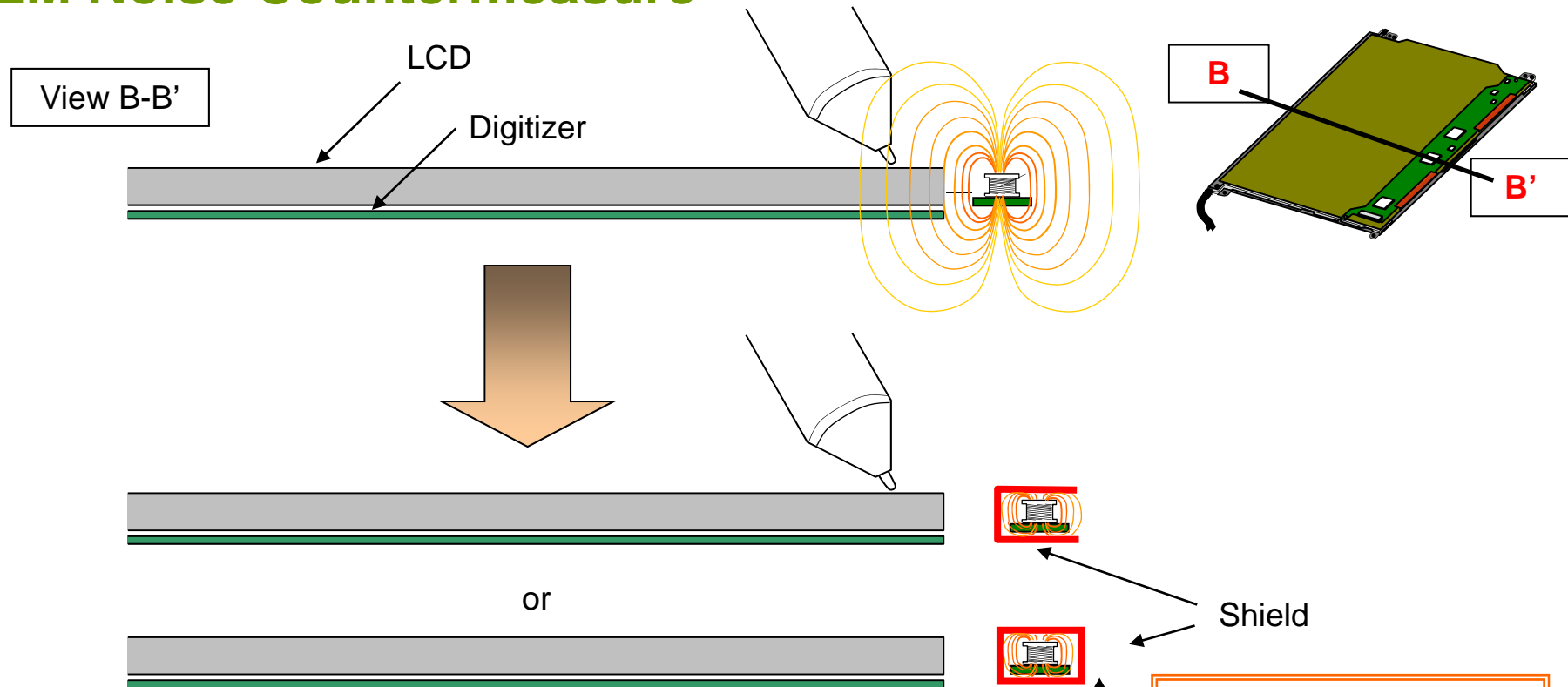

Digitizer is sensitive to Electromagnetic Noise.  
Inverter is one of the strongest EM source.  
Shielding the inverter with shield plate\*1, would improve an affection of the EM noise from the Inverter.

**IMPORTANT**

As far as you can, please  
**SEPARATE** the Digitizer Unit  
from the Inverter

# 7-3. System Designing

## EM Noise Countermeasure2

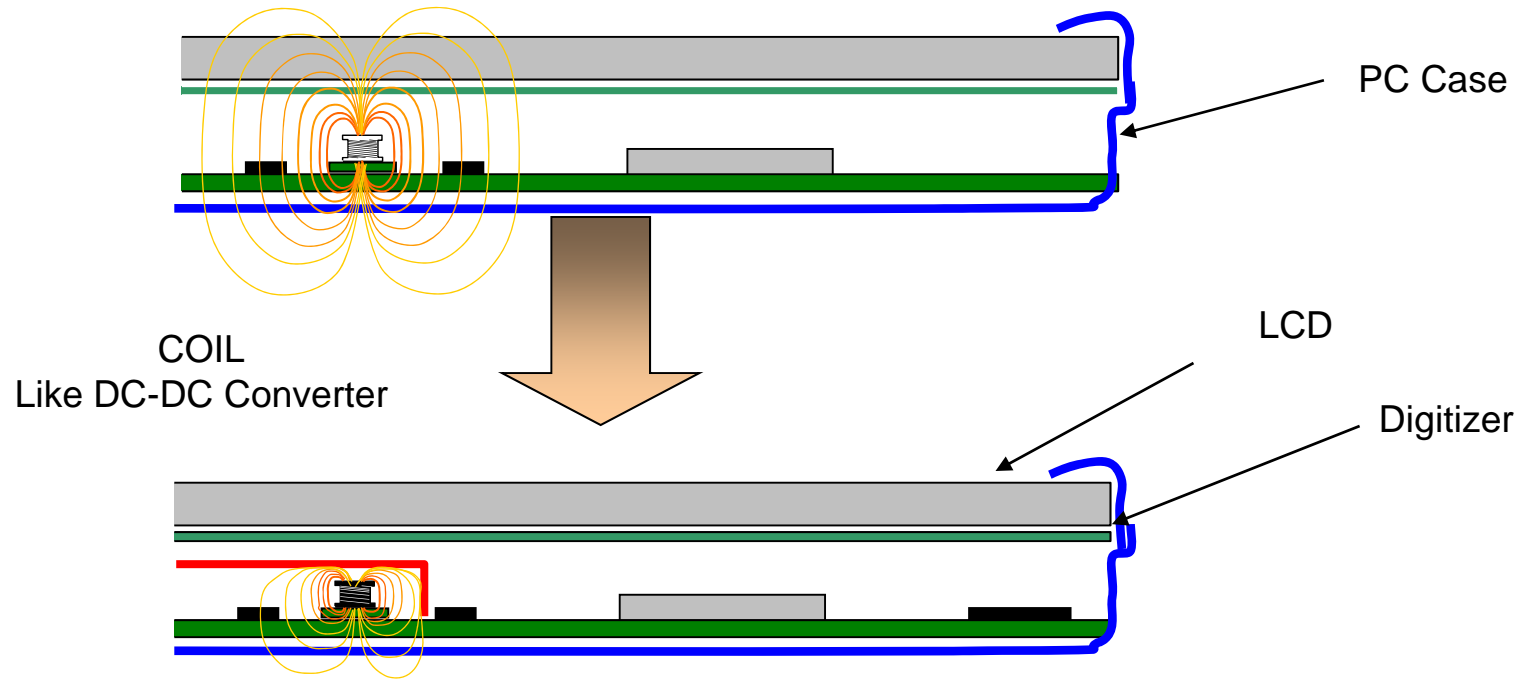

In case of PC in one body, motherboard is located right beneath the Digitizer unit. Coils in the power unit generates the EM noise and it will cause of inaccuracy of the Digitizer.

Shield the COIL with shield plate\*1 for better Digitizer quality.

# 7-4. System Designing

## Example of Noise Shield1

Noise Source

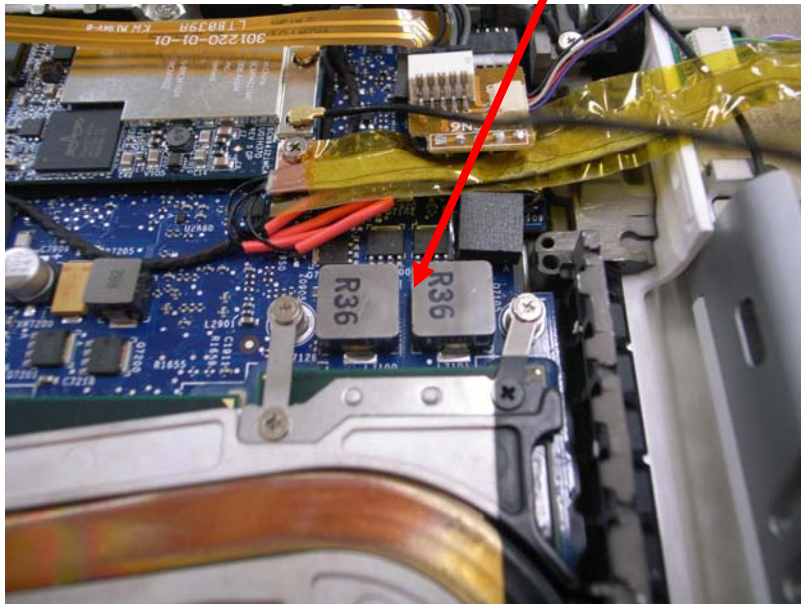

Shielded

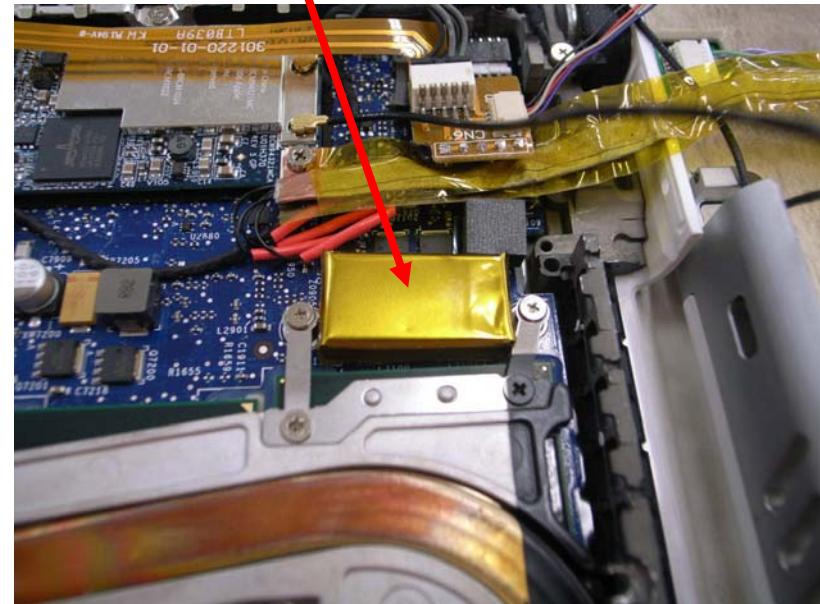

# 7-5. System Designing

## Example of Noise Shield2

Noise Source

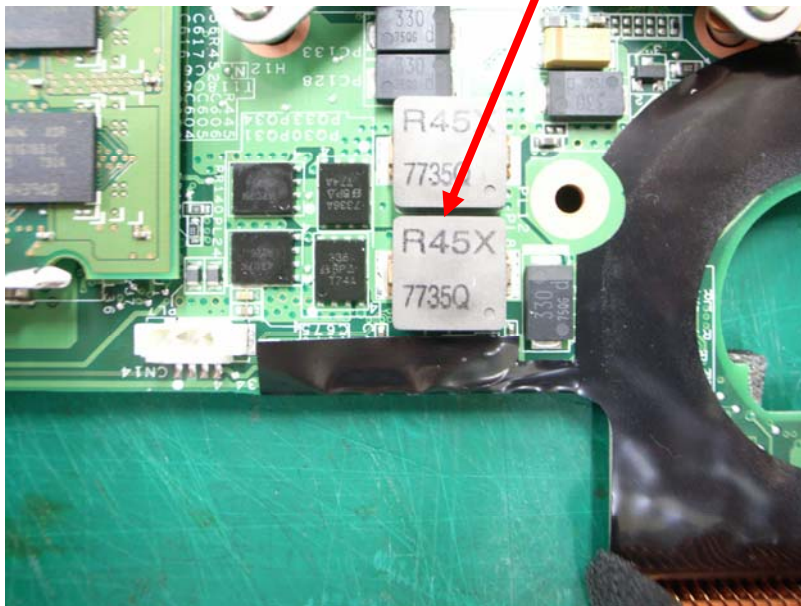

Shielded

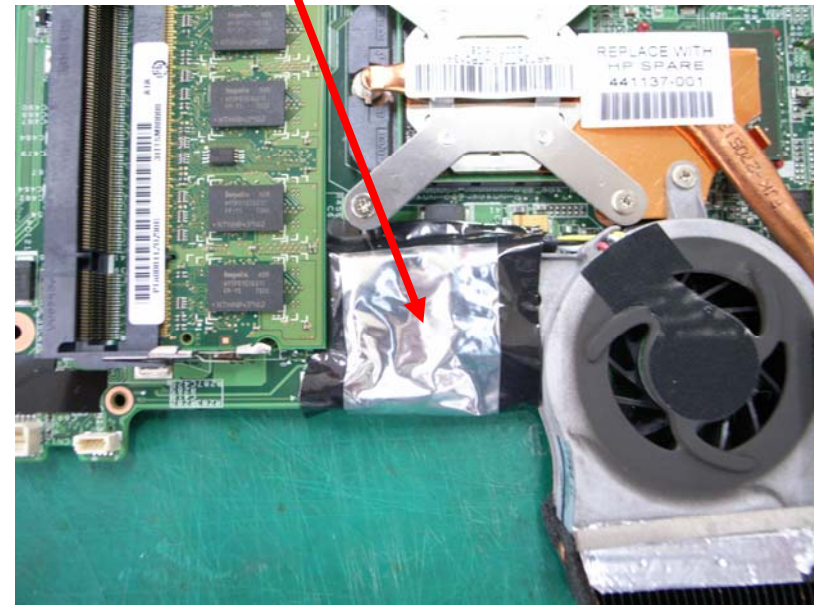

# 8-1. System Designing2

## Reduction of metal influence

Some metal structure reduces digitizer signal which causes coordinate error.

To prevent this

- Do not use metal for upper case.
- Contact Wacom to make Error calibrated firmware data.

Metal influence source

- LCD metal bezel and lamp cover
- Upper case ( if it is made of metal )

# 8-2. System Designing2

## Minimize Metal influence

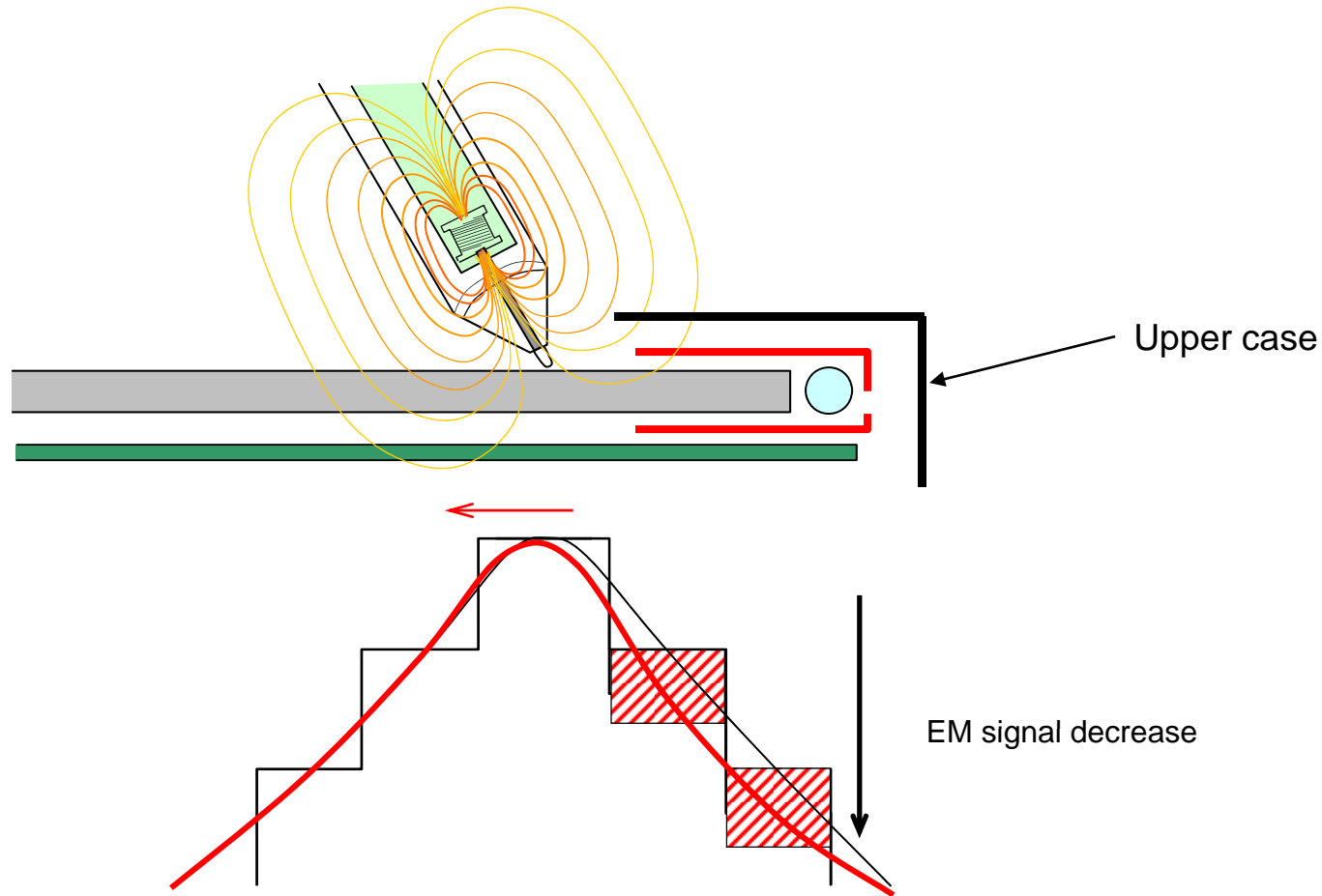

Metal on the digitizer will disturb the EM signal from the pen.



# 8-3. System Designing2

## Bad Example of Metal Parts1

### Full Metal Upper Case



# 8-4. System Designing2

Bad Example of Metal Parts2

Wrapped by Metal Sheet



# 9-1. System Calibration

- Wacom will do following evaluation in order to prevent adverse affect from EM noise and metal parts
  1. EM noise environment
  2. Coordinate stability
  3. Coordinate accuracy
- Wacom will provide FW data and evaluation report.
- Calibration work will take approximately 1-2 weeks.
- Calibration work charge is US\$1,200 per calibration.

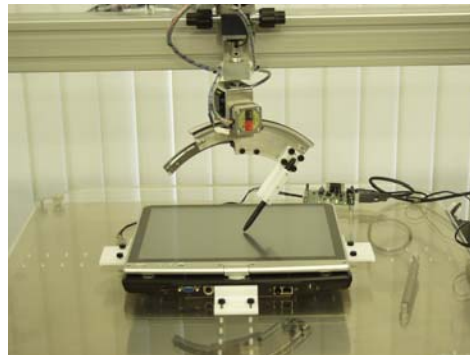

# 9-2. System Calibration

- EM noise environment
  - EM noise which mimic pen signal can cause digitizer malfunction.
  - Wacom will search the EM noise and measure the level.

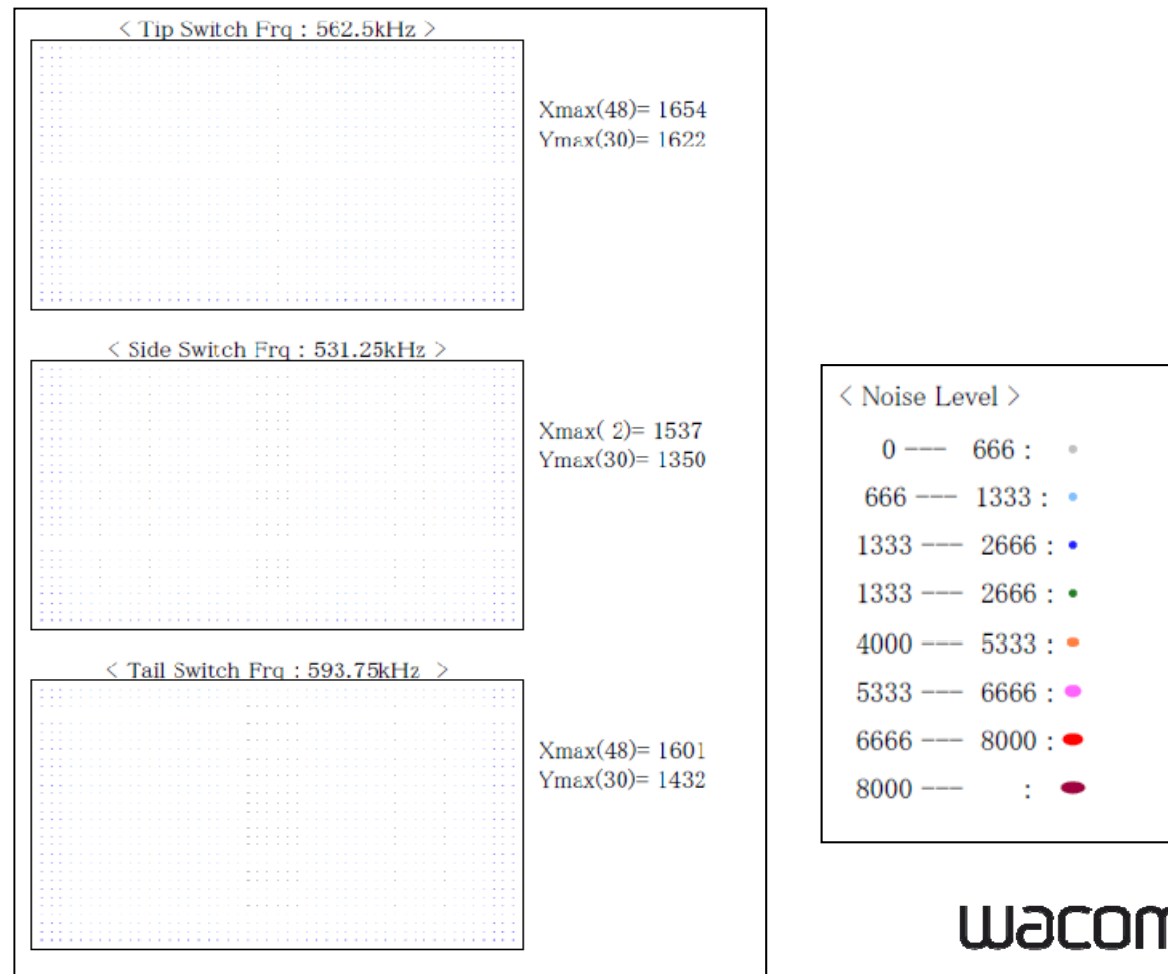

# 9-3. System Calibration

- Coordinate stability
  - EM noise can cause vibration of coordinate detected by digitizer (jitter).
  - Wacom quantifies the level of jitter by take 100 coordinate data at each spot and calculating standard deviation and max deviation from mean location.

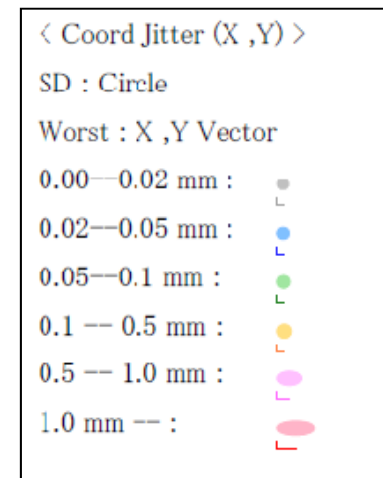

# 9-4. System Calibration

- Coordinate accuracy before calibration
  - Metal parts or EM noise will disturb digitizer signal and can cause the deterioration of digitizer accuracy.
  - Digitizer signal can be compensated by calibration up to certain level.
  - Wacom measures the accuracy before and after calibration.

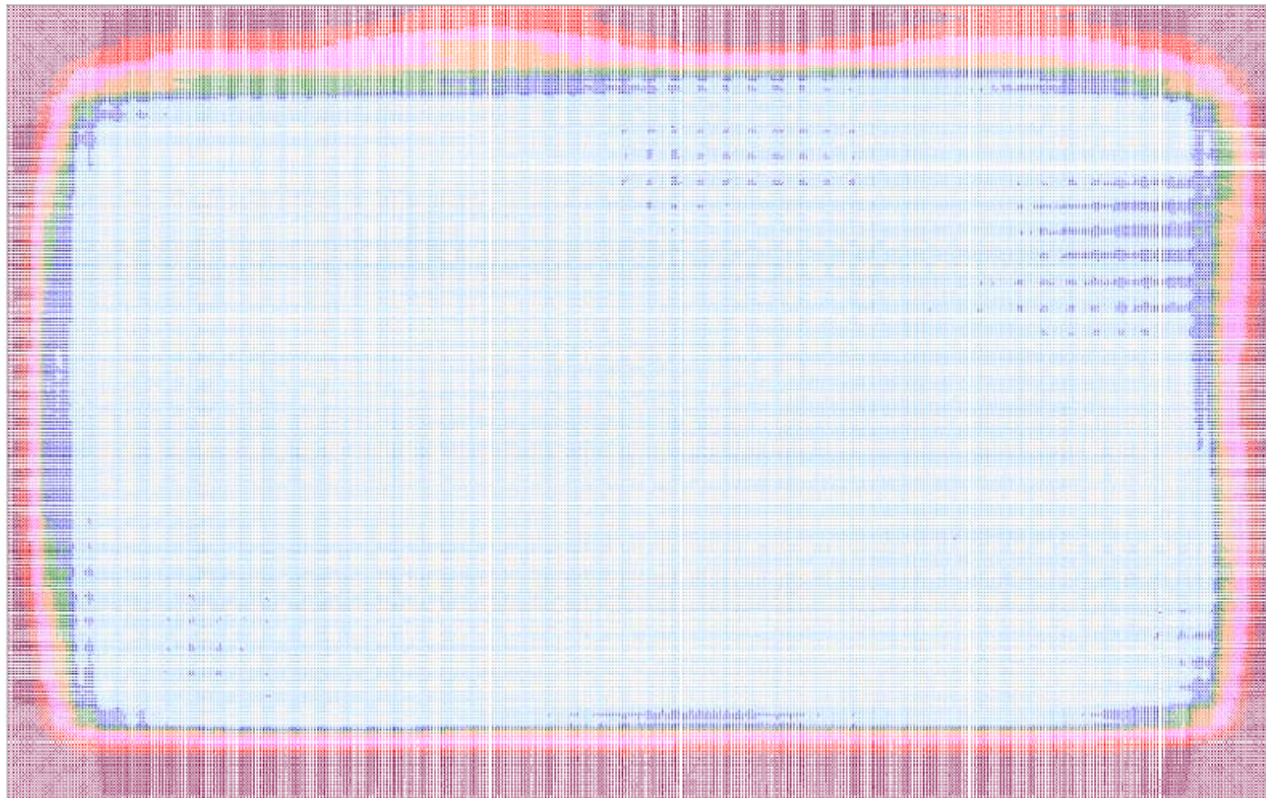

< Coord Accuracy >	
0.0 ~ 0.1 mm :	•
0.1 ~ 0.3 mm :	•
0.3 ~ 0.5 mm :	•
0.5 ~ 0.7 mm :	•
0.7 ~ 1.0 mm :	•
1.0 ~ 1.5 mm :	•
1.5 ~ 2.0 mm :	•
2.0 mm ~ :	•

# 9-5. System Calibration

- Coordinate accuracy after calibration

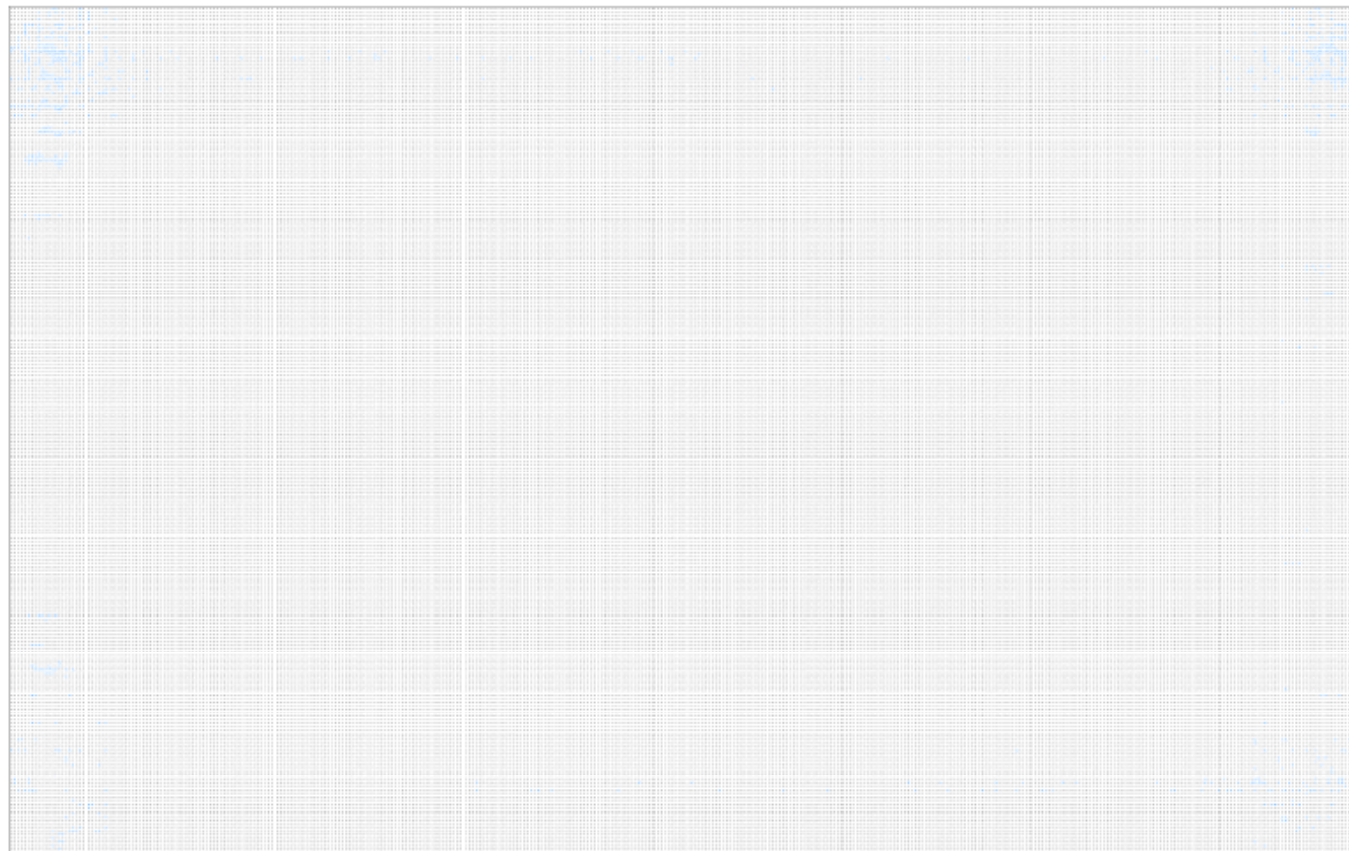

< Coord Accuracy >	
0.0 ~ 0.1 mm :	•
0.1 ~ 0.3 mm :	•
0.3 ~ 0.5 mm :	•
0.5 ~ 0.7 mm :	•
0.7 ~ 1.0 mm :	•
1.0 ~ 1.5 mm :	•
1.5 ~ 2.0 mm :	•
2.0 mm ~ :	•

# 9-6. System Calibration

- **Before sending calibration machine, please check below items.**
  1. Final design
  2. Tooled product
  3. All criteria for system design is followed
  4. All accessories (eg. AC adaptor) are enclosed
  5. Valid OS is installed
  6. Wacom stylus (which pen to use with)
  7. Assembly drawing to show LCD and digitizer position
- **Note:**
  - Calibration is required for each design. Any material or design changes will need another calibration.
  - When several LCDs are applied for one model, FW needs to be created for each LCD.



# 10. Driver

- **Device Driver**

- Windows Vista, Windows XP, Windows 2000, Windows CE ,  
Symbian

- **Note:**

- for dual touch, standard interface is USB