



**RADIATED SPURIOUS EMISSIONS PORTIONS OF
FCC CFR47 PART 22H & 24E
INDUSTRY CANADA RSS-132 ISSUE 2
INDUSTRY CANADA RSS-133 ISSUE 5**

**CERTIFICATION TEST REPORT
FOR
LENOVO TABLET PC WITH GSM AND WCDMA**

**FCC MODEL NUMBER: TP00042A
IC MODEL NUMBER: TP00042AHJ**

**FCC ID: GKR-TP00042AHJ
IC: 2533B-TP00042AHJ**

**REPORT NUMBER: 12U14543-3C
ISSUE DATE: December 13 2012**

Prepared for

**Compal Electronics, Inc
No. 581, Ruiguang Rd., Neihu District
Taipei City 11492, Taiwan (R.O.C)**

Prepared by

**Underwriters Laboratories Inc.
333 Pfingsten Rd.
Northbrook, IL 60062
TEL: (847) 272-8800**



NVLAP Lab code: 100414-0

Revision History

Rev.	Date	Revisions	Revised By
---	08/07/12	Initial Issue	M.Ferrer
A	09/17/12	Added C2PC info	M.Ferrer
B	10/26/12	Revised Section 5.2 and ERP/ERIP Tables	M.Ferrer
C	12/13/12	Corrected ERP calculation	M.Ferrer

TABLE OF CONTENTS

1. ATTESTATION OF TEST RESULTS 4

2. TEST METHODOLOGY 5

3. FACILITIES AND ACCREDITATION 5

4. CALIBRATION AND UNCERTAINTY 5

 4.1. *MEASURING INSTRUMENT CALIBRATION* 5

 4.2. *SAMPLE CALCULATION* 5

 4.3. *MEASUREMENT UNCERTAINTY* 5

5. EQUIPMENT UNDER TEST 6

 5.1. *DESCRIPTION OF EUT* 6

 5.2. *Class II Permissive Change Summary* 6

 5.3. *MAXIMUM ERP/ERIP POWER* 6

 5.4. *DESCRIPTION OF AVAILABLE ANTENNAS* 7

 5.5. *SOFTWARE AND FIRMWARE* 7

 5.6. *WORST-CASE CONFIGURATION AND MODE* 7

 5.7. *DESCRIPTION OF TEST SETUP* 8

6. TEST AND MEASUREMENT EQUIPMENT10

7. RADIATED TEST RESULTS.....11

 7.1. *RADIATED POWER (ERP & EIRP)* 11

 7.2. *FIELD STRENGTH OF SPURIOUS RADIATION* 19

8. SETUP PHOTOS.....26

1. ATTESTATION OF TEST RESULTS

COMPANY NAME: Compal Electronics, Inc
 No. 581, Ruiguang Rd., Neihu District
 Taipei City 11492, Taiwan (R.O.C)

EUT DESCRIPTION: Lenovo Tablet PC with GSM/WCDMA

FCC MODEL NUMBER: TP00042A
IC MODEL NUMBER: TP00042AHJ

SERIAL NUMBER: Prototype

DATE TESTED: July 31, 2012 – September 24, 2012

APPLICABLE STANDARDS	
STANDARD	TEST RESULTS
FCC PART 22H & 24E	Pass
IC RSS132 AND IC RSS133	Pass

UL tested the above equipment in accordance with the requirements set forth in the above standards. All indications of Pass/Fail in this report are opinions expressed by UL based on interpretations and/or observations of test results. Measurement Uncertainties were not taken into account and are published for informational purposes only. The test results show that the equipment tested is capable of demonstrating compliance with the requirements as documented in this report.

Note: The results documented in this report apply only to the tested sample, under the conditions and modes of operation as described herein. This document may not be altered or revised in any way unless done so by UL and all revisions are duly noted in the revisions section. Any alteration of this document not carried out by UL will constitute fraud and shall nullify the document. This report must not be used by the client to claim product certification, approval, or endorsement by NVLAP, NIST, any agency of the Federal Government, or any agency of any government.

Approved & Released For UL By:

Tested By:



BART MUCHA
 Staff Engineer
 UL

MICHAEL FERRER
 SENIOR PROJECT ENGINEER
 UL

2. TEST METHODOLOGY

The tests documented in this report were performed in accordance with TIA-603-C, FCC CFR 47 Part 2, FCC CFR 47 Part 22, FCC CFR Part 24, RSS-132 Issue 2, and RSS-133 Issue 5.

3. FACILITIES AND ACCREDITATION

The test sites and measurement facilities used to collect data are located at 333 Pfingsten Road, Northbrook, IL 60193, USA.

UL NBK is accredited by NVLAP, Laboratory Code 100414-0

4. CALIBRATION AND UNCERTAINTY

4.1. MEASURING INSTRUMENT CALIBRATION

The measuring equipment utilized to perform the tests documented in this report has been calibrated in accordance with the manufacturer's recommendations, and is traceable to recognized national standards

4.2. SAMPLE CALCULATION

Sample Calculations

Radiated Field Strength and Conducted Emissions data contained within this report is calculated on the following basis:

$$\text{Field Strength (dBuV/m)} = \text{Meter Reading (dBuV)} + \text{AF (dB/m)} - \text{Gain (dB)} + \text{Cable Loss (dB)}$$

$$\text{Conducted Voltage (dBuV)} = \text{Meter Reading (dBuV)} + \text{Cable Loss (dB)} + \text{LISN IL (dB)}$$

$$\text{Conducted Current (dBuA)} = \text{Meter Reading (dBuV)} + \text{Cable Loss (dB)} - \text{Transducer Factor (dBohms)}$$

$$\text{ERP EUT level} = \text{Delta EUT and Substitution} + \text{ERP level}$$

$$\text{ERIP EUT level} = \text{Delta EUT and Substitution} + \text{ERIP level}$$

$$\text{Delta EUT and Substitution} = \text{Substitution Peak field} - \text{EUT Measured peak level}$$

$$\text{ERP Substitution} = \text{ERIP level} + 2.15$$

$$\text{ERIP level} = \text{Voltage at Antenna} + \text{TX ant gain}$$

4.3. MEASUREMENT UNCERTAINTY

Where relevant, the following measurement uncertainty levels have been estimated for tests performed on the apparatus:

PARAMETER	UNCERTAINTY
Conducted Disturbance, 0.15 to 30 MHz	+/- 0.3 dB (k=2)
Radiated Disturbance, 30 to 1000 MHz	+/- 3.17 dB (k=2)

Uncertainty figures are valid to a confidence level of 95%.

5. EQUIPMENT UNDER TEST

5.1. DESCRIPTION OF EUT

The EUT is a tablet PC with GSM / WCDMA feature that produced by Compal Electronics, Inc.

5.2. Class II Permissive Change Summary

The major change filed under this application is:

Change #1 Adding 2nd source for WLAN and WWAN antenna.

5.3. MAXIMUM ERP/ERIP POWER

The transmitter has a maximum ERP/ERIP output powers as follows:

Part 22 Cellular Band

Frequency range (MHz)	Modulation	ERP	
		dBm	mW
824.2 – 848.8	GPRS	27.03	505.13
	EGPRS	27.07	509.38
826.4 – 846.6	WCDMA REL 99	20.30	107.23
	WCDMA HSUPA	19.27	84.53

Part 24 PCS Band

Frequency range (MHz)	Modulation	ERIP	
		dBm	mW
1850.2-1909.8	GPRS	28.08	643.28
	EGPRS	27.58	573.32
1852.4-1907.6	WCDMA REL99	24.87	307.18
	WCDMA HSUPA	25.21	331.89

5.4. DESCRIPTION OF AVAILABLE ANTENNAS

The radio utilizes an integral antenna for the 850MHz and 1900MHz bands with a maximum peak gain as follow:

BANDS	Peak Gain (dBi)
GSM, CELL, 850MHz	-2.54
GSM,PCS, 1900MHz	2.08
UMTS, 850MHz	-2.54
UMTS, 1900MHZ	2.08

Brand Name	Antenna Type	Model Name
Wistron Neweb Corp.	WWAN MAIN R	81.EG915.G32
(WNC)	WWAN AUX L	81.EG915.G33
	WLAN MAIN L	81.EG915.G34
	WLAN AUX R	81.EG915.G35

5.5. SOFTWARE AND FIRMWARE

The EUT is linked with Anritsu MT8820C Communication Test Set.

5.6. WORST-CASE CONFIGURATION AND MODE

The worst-case channel for RF radiated emissions below 1GHz and AC conducted emissions are determined as the channel with the AC Power Adapter Source

Based on the investigation results, the highest peak power and enhanced data rate is the worst-case scenario for all measurements.

Worst-case modes below:

- For Cellular and PCS band: GPRS and EGPRS
- For Cellular and PCS band: WCDMA (UMTS).

For the fundamental investigation, since the EUT is a portable device that has three orientations; therefore X, Y and Z orientations have been investigated. The worst case was found to be at Tablet configuration Z-position for all modes in cell band, Tablet configuration Z-position on PCS bands for GPRS, EGPRS, and WCDMA modes.

5.7. DESCRIPTION OF TEST SETUP

SUPPORT EQUIPMENT (RF RADIATED TEST)

PERIPHERAL SUPPORT EQUIPMENT LIST				
Description	Manufacturer	Model	Serial Number	FCC ID
AC Adapter	Lenovo	42T4416	11S42T4416Z1ZGWF0	DoC

I/O CABLES (RF RADIATED TEST)

I/O CABLE LIST						
Cable No.	Port	# of Identical Ports	Connector Type	Cable Type	Cable Length	Remarks
1	DC	1	DC	Un-shielded	8 ft	AC adapter

TEST SETUP

The EUT is a stand-alone device. A link is established between the EUT and the communication test set

Call Box was set for tablet to transmit at highest level possible.

SETUP DIAGRAM FOR RF RADIATED TESTS

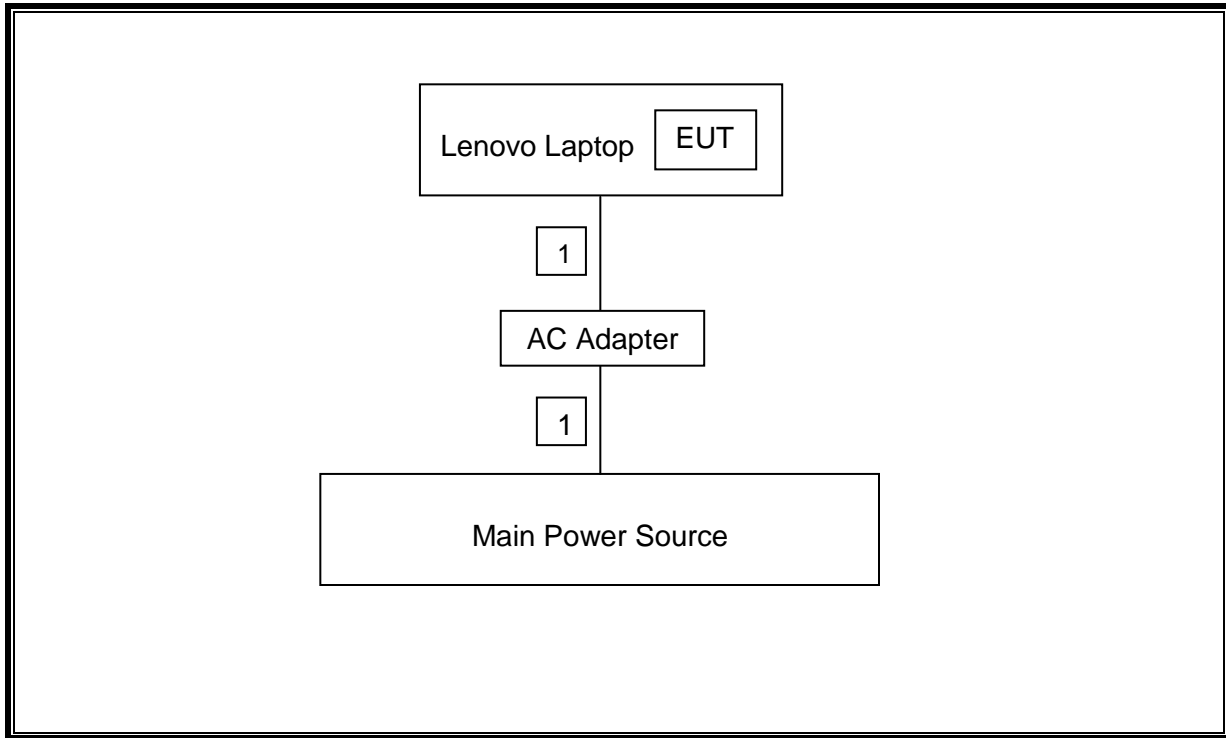

6. TEST AND MEASUREMENT EQUIPMENT

The following test and measurement equipment was utilized for the tests documented in this report:

TEST EQUIPMENT LIST				
Description	Manufacturer	Model	Asset	Cal Due
EMI Test Receiver	Rohde & Schwarz	ESCI	EMC4328	20121231
Bicon Antenna	Chase	VBA6106A	EMC4078	20130131
Log-P Antenna	Chase	UPA6109	EMC4258	20120928
Log-P Antenna (TX)	Chase	UPA6109	EMC4313	20120731
Spectrum Analyzer	Rhode & Schwarz	FSEK	EMC4182	20121231
Antenna Array	UL	BOMS	EMC4276	20121231
Signal Generator	Rohde & Schwarz	SML 03	EMC 4331	20121231
Signal Generator	Agilent	E8251A	EMC4243	20121231
Call Box	Anritsu	MT8820C	EMC4361	20130910

7. RADIATED TEST RESULTS

7.1. RADIATED POWER (ERP & EIRP)

RULE PART(S)

FCC: §2.1046, §22.913, §24.232
RSS132 & RSS133

LIMITS

22.913(a) - The ERP of mobile transmitters and auxiliary test transmitters must not exceed 7 Watts.

24.232(c) - Mobile/portable stations are limited to 2 watts e.i.r.p. peak power and the equipment must employ means to limit the power to the minimum necessary for successful communications.

TEST PROCEDURE

ANSI / TIA / EIA 603C Clause 2.2.17

MODES TESTED

- GPRS and EGPRS
- WCDMA

RESULTS

In the table of results the Voltage at the antenna includes signal generator level and cable loss
EUT level will be EUT measured level – Substitution measured +ERP Level (or EIRP level)

ERP CELL BANDS

Mode	Channel	f (MHz)	ERP	
			dBm	mW
GPRS	128	824.20	27.03	505.13
	190	836.60	26.98	499.23
	251	848.80	26.78	475.95
EGRS	128	824.20	27.07	509.38
	190	836.60	26.94	494.65
	251	848.80	26.70	467.26

Mode	Channel	f (MHz)	ERP	
			dBm	mW
WCDMA REL99	128	826.40	19.71	93.55
	190	836.60	20.30	107.23
	251	846.80	19.94	98.53
WCDMA HSUPA	128	826.40	17.85	60.95
	190	836.60	19.27	84.53
	251	846.80	18.66	73.45

EIRP PCS BANDS

EUT	Channel	f (MHz)	EIRP	
			dBm	mW
GPRS	512	1850.20	27.08	510.66
	661	1880.00	28.08	643.28
	810	1909.80	26.62	458.78
EGPRS	512	1850.20	26.70	467.88
	661	1880.00	27.58	573.32
	810	1909.80	26.06	403.27

EUT	Channel	f (MHz)	EIRP	
			dBm	mW
WCDMA REL99	9662	1852.40	24.32	270.30
	9800	1880.00	24.87	307.18
	9938	1907.60	24.12	258.46
WCDMA HSUPA	9662	1852.40	23.93	247.17
	9800	1880.00	25.21	331.89
	9938	1907.60	23.64	231.21

GPRS (Cellular Band)

Description	Freq. MHz	Polarization	Voltage at antenna dBm	Substitution Peak Filed Strenght Measured dBuV/m	TX ant dBi	EIRP Level	ERP Level dBm	EUT Measured Peak Level dBuV/m	Delta EUT and Substitution dB	ERP EUT Level dBm	Limit dBm/MHz	Margin dB
GPRS Slot 1												
Low	824.2	Horizontal	-51.38	54.83	5.584	-45.796	-47.946	129.81	74.98	27.034	38.45	-11.416
		Vertical	-51.38	53.07	5.284	-46.096	-48.246	124.97	71.9	23.654	38.45	-14.796
Mid	836.6	Horizontal	-51.42	54.28	5.5	-45.92	-48.07	129.09	74.81	26.74	38.45	-11.71
		Vertical	-51.42	53.78	5.334	-46.086	-48.236	124.38	70.6	22.364	38.45	-16.086
Hi	848.8	Horizontal	-51.43	54.55	5.588	-45.842	-47.992	129.27	74.72	26.728	38.45	-11.722
		Vertical	-51.43	53.02	5.476	-45.954	-48.104	124.09	71.07	22.966	38.45	-15.484
GPRS Slot 2												
Low	824.2	Horizontal	-51.38	54.83	5.7004	-45.68	-47.83	129.68	74.85	27.0204	38.45	-11.4296
		Vertical	-51.38	53.07	5.7148	-45.665	-47.815	124.88	71.81	23.9948	38.45	-14.4552
Mid	836.6	Horizontal	-51.42	54.28	5.713	-45.707	-47.857	129.12	74.84	26.983	38.45	-11.467
		Vertical	-51.42	53.78	5.6785	-45.742	-47.892	124.52	70.74	22.8485	38.45	-15.6015
Hi	848.8	Horizontal	-51.43	54.55	5.7256	-45.704	-47.854	129.18	74.63	26.7756	38.45	-11.6744
		Vertical	-51.43	53.02	5.6427	-45.787	-47.937	124.07	71.05	23.1127	38.45	-15.3373

EGPRS (Cellular Band)

Description	Freq. MHz	Polarization	Voltage at antenna dBm	Substitution Peak Filed Strenght Measured dBuV/m	TX ant dBi	EIRP Level	ERP Level dBm	EUT Measured Peak Level dBuV/m	Delta EUT and Substitution dB	ERP EUT Level dBm	Limit dBm/MHz	Margin dB
EGPRS Slot 1												
Low	824.2	Horizontal	-51.38	54.83	5.584	-45.796	-47.946	129.8	74.97	27.024	38.45	-11.426
		Vertical	-51.38	53.07	5.284	-46.096	-48.246	125.14	72.07	23.824	38.45	-14.626
Mid	836.6	Horizontal	-51.42	54.28	5.5	-45.92	-48.07	129.15	74.87	26.8	38.45	-11.65
		Vertical	-51.42	53.78	5.334	-46.086	-48.236	124.59	70.81	22.574	38.45	-15.876
Hi	848.8	Horizontal	-51.43	54.55	5.588	-45.842	-47.992	129.15	74.6	26.608	38.45	-11.842
		Vertical	-51.43	53.02	5.476	-45.954	-48.104	124.13	71.11	23.006	38.45	-15.444
EGPRS Slot 2												
Low	824.2	Horizontal	-51.38	54.83	5.7004	-45.68	-47.83	129.73	74.9	27.0704	38.45	-11.3796
		Vertical	-51.38	53.07	5.7148	-45.665	-47.815	125	71.93	24.1148	38.45	-14.3352
Mid	836.6	Horizontal	-51.42	54.28	5.713	-45.707	-47.857	129.08	74.8	26.943	38.45	-11.507
		Vertical	-51.42	53.78	5.6785	-45.742	-47.892	124.29	70.51	22.6185	38.45	-15.8315
Hi	848.8	Horizontal	-51.43	54.55	5.7256	-45.704	-47.854	129.1	74.55	26.6956	38.45	-11.7544
		Vertical	-51.43	53.02	5.6427	-45.787	-47.937	124.11	71.09	23.1527	38.45	-15.2973

WCDMA (Cellular Band)

Description	Freq. MHz	Polarization	Voltage at antenna dBm	Substitution Peak Filed Strenght Measured dBuV/m	TX ant dBi	EIRP Level	ERP Level dBm	EUT Measured Peak Level dBuV/m	Delta EUT and Substitution dB	ERP EUT Level dBm	Limit dBm/MHz	Margin dB
WCDMA	Rel99											
Low	826.4	Horizontal	-38.98	68.02	5.7004	-33.28	-35.43	121.05	53.03	17.6004	38.45	-20.8496
		Vertical	-38.98	68.02	5.7148	-33.265	-35.415	116.08	48.06	12.6448	38.45	-25.8052
Mid	836.6	Horizontal	-38.98	67.18	5.713	-33.267	-35.417	121.54	54.36	18.943	38.45	-19.507
		Vertical	-38.98	67.18	5.6785	-33.302	-35.452	117.52	50.34	14.8885	38.45	-23.5615
Hi	846.6	Horizontal	-38.9	68.02	5.7256	-33.174	-35.324	122.01	53.99	18.6656	38.45	-19.7844
		Vertical	-38.9	68.02	5.6427	-33.257	-35.407	118.32	50.3	14.8927	38.45	-23.5573
WCDMA	HSUPA											
SubSet1	826.4	Horizontal	-38.98	68.02	5.7004	-33.28	-35.43	120.88	52.86	17.4304	38.45	-21.0196
		Vertical	-38.98	68.02	5.7148	-33.265	-35.415	116.89	48.87	13.4548	38.45	-24.9952
SubSet2	826.4	Horizontal	-38.98	68.02	5.7004	-33.28	-35.43	120.92	52.9	17.4704	38.45	-20.9796
		Vertical	-38.98	68.02	5.7148	-33.265	-35.415	116.84	48.82	13.4048	38.45	-25.0452
SubSet3	826.4	Horizontal	-38.98	68.02	5.7004	-33.28	-35.43	120.93	52.91	17.4804	38.45	-20.9696
		Vertical	-38.98	68.02	5.7148	-33.265	-35.415	116.83	48.81	13.3948	38.45	-25.0552
SubSet4	826.4	Horizontal	-38.98	68.02	5.7004	-33.28	-35.43	121.3	53.28	17.8504	38.45	-20.5996
		Vertical	-38.98	68.02	5.7148	-33.265	-35.415	116.91	48.89	13.4748	38.45	-24.9752
SubSet5	826.4	Horizontal	-38.98	68.02	5.7004	-33.28	-35.43	121.04	53.02	17.5904	38.45	-20.8596
		Vertical	-38.98	68.02	5.7148	-33.265	-35.415	116.76	48.74	13.3248	38.45	-25.1252
SubSet1	836.6	Horizontal	-38.98	67.18	5.713	-33.267	-35.417	121.29	54.11	18.693	38.45	-19.757
		Vertical	-38.98	67.18	5.6785	-33.302	-35.452	117.78	50.6	15.1485	38.45	-23.3015
SubSet2	836.6	Horizontal	-38.98	67.18	5.713	-33.267	-35.417	121.68	54.5	19.083	38.45	-19.367
		Vertical	-38.98	67.18	5.6785	-33.302	-35.452	118.33	51.15	15.6985	38.45	-22.7515
SubSet3	836.6	Horizontal	-38.98	67.18	5.713	-33.267	-35.417	121.53	54.35	18.933	38.45	-19.517
		Vertical	-38.98	67.18	5.6785	-33.302	-35.452	117.66	50.48	15.0285	38.45	-23.4215
SubSet4	836.6	Horizontal	-38.98	67.18	5.713	-33.267	-35.417	121.87	54.69	19.273	38.45	-19.177
		Vertical	-38.98	67.18	5.6785	-33.302	-35.452	117.75	50.57	15.1185	38.45	-23.3315
SubSet5	836.6	Horizontal	-38.98	67.18	5.713	-33.267	-35.417	121.72	54.54	19.123	38.45	-19.327
		Vertical	-38.98	67.18	5.6785	-33.302	-35.452	118.59	51.41	15.9585	38.45	-22.4915
SubSet1	846.6	Horizontal	-38.98	68.02	5.7004	-33.28	-35.43	122.11	54.09	18.6604	38.45	-19.7896
		Vertical	-38.98	68.02	5.7148	-33.265	-35.415	118.97	50.95	15.5348	38.45	-22.9152
SubSet2	846.6	Horizontal	-38.98	68.02	5.7004	-33.28	-35.43	121.46	53.44	18.0104	38.45	-20.4396
		Vertical	-38.98	68.02	5.7148	-33.265	-35.415	119.04	51.02	15.6048	38.45	-22.8452
SubSet3	846.6	Horizontal	-38.98	68.02	5.7004	-33.28	-35.43	121.66	53.64	18.2104	38.45	-20.2396
		Vertical	-38.98	68.02	5.7148	-33.265	-35.415	118.97	50.95	15.5348	38.45	-22.9152
SubSet4	846.6	Horizontal	-38.98	68.02	5.7004	-33.28	-35.43	122.05	54.03	18.6004	38.45	-19.8496
		Vertical	-38.98	68.02	5.7148	-33.265	-35.415	118.98	50.96	15.5448	38.45	-22.9052
SubSet5	846.6	Horizontal	-38.98	68.02	5.7004	-33.28	-35.43	121.9	53.88	18.4504	38.45	-19.9996
		Vertical	-38.98	68.02	5.7148	-33.265	-35.415	119.19	51.17	15.7548	38.45	-22.6952

GPRS (PCS Band)

Description	Freq. MHz	Polarization	Voltage at antenna dBm	Substitution Peak Filed Strenght Measured dBuV/m	TX ant dBi	EIRP Level	EUT Measured Peak Level dBuV/m	Delta EUT and Substitution dB	EIRP EUT Level dBm	Limit dBm/MHz	Margin dB
GPRS Slot 1											
Low	1850.2	Horizontal	-25.88	78.26	4.7313	-21.149	126.47	48.21	27.0613	33	-5.9387
		Vertical	-50.96	51.52	4.628	-46.332	119.5	67.98	21.648	33	-11.352
Mid	1880	Horizontal	-26.05	77.94	4.694	-21.356	127.12	49.18	27.824	33	-5.176
		Vertical	-51.08	50.56	4.4192	-46.661	120.89	70.33	23.6692	33	-9.3308
Hi	1909.8	Horizontal	-51.1	52.8	4.676	-46.424	125.82	73.02	26.596	33	-6.404
		Vertical	-51.1	51.02	4.332	-46.768	117.39	66.37	19.602	33	-13.398
GPRS Slot 2											
Low	1850.2	Horizontal	-25.88	78.26	4.7313	-21.149	126.49	48.23	27.0813	33	-5.9187
		Vertical	-50.96	51.52	4.628	-46.332	119.66	68.14	21.808	33	-11.192
Mid	1880	Horizontal	-26.05	77.94	4.694	-21.356	127.38	49.44	28.084	33	-4.916
		Vertical	-51.08	50.56	4.4192	-46.661	120.81	70.25	23.5892	33	-9.4108
Hi	1909.8	Horizontal	-51.1	52.8	4.676	-46.424	125.84	73.04	26.616	33	-6.384
		Vertical	-51.1	51.02	4.332	-46.768	117.28	66.26	19.492	33	-13.508

EGPRS (PCS Band)

Description	Freq. MHz	Polarization	Voltage at antenna dBm	Substitution Peak Filed Strenght Measured dBuV/m	TX ant dBi	EIRP Level	EUT Measured Peak Level dBuV/m	Delta EUT and Substitution dB	EIRP EUT Level dBm	Limit dBm/MHz	Margin dB
EGPRS Slot 1											
Low	1850.2	Horizontal	-25.88	78.26	4.7313	-21.149	126.11	47.85	26.7013	33	-6.2987
		Vertical	-50.96	51.52	4.628	-46.332	119.11	67.59	21.258	33	-11.742
Mid	1880	Horizontal	-26.05	77.94	4.694	-21.356	126.88	48.94	27.584	33	-5.416
		Vertical	-51.08	50.56	4.4192	-46.661	120.05	69.49	22.8292	33	-10.1708
Hi	1909.8	Horizontal	-51.1	52.8	4.676	-46.424	125.28	72.48	26.056	33	-6.944
		Vertical	-51.1	51.02	4.332	-46.768	117.15	66.13	19.362	33	-13.638
EGPRS Slot 2											
Low	1850.2	Horizontal	-25.88	78.26	4.7313	-21.149	126.11	47.85	26.7013	33	-6.2987
		Vertical	-50.96	51.52	4.628	-46.332	119.05	67.53	21.198	33	-11.802
Mid	1880	Horizontal	-26.05	77.94	4.694	-21.356	126.75	48.81	27.454	33	-5.546
		Vertical	-51.08	50.56	4.4192	-46.661	119.84	69.28	22.6192	33	-10.3808
Hi	1909.8	Horizontal	-51.1	52.8	4.676	-46.424	125.23	72.43	26.006	33	-6.994
		Vertical	-51.1	51.02	4.332	-46.768	117.11	66.09	19.322	33	-13.678

WCDMA (PCS Band)

Description	Freq. MHz	Polarization	Voltage at antenna dBm	Substitution Peak Filed Strenght Measured dBuV/m	TX ant dBi	EIRP Level	EUT Measured Peak Level dBuV/m	Delta EUT and Substitution dB	EIRP EUT Level dBm	Limit dBm/MHz	Margin dB
WCDMA	Rel99										
Low	1852.4	Horizontal	-51.02	52.95	4.7285	-46.292	122.9	69.95	23.6585	33	-9.3415
		Vertical	-51.02	51.89	4.612	-46.408	120.97	69.08	22.672	33	-10.328
Mid	1880	Horizontal	-51.08	52.73	4.694	-46.386	123.52	70.79	24.404	33	-8.596
		Vertical	-51.08	50.56	4.4192	-46.661	118.96	68.4	21.7392	33	-11.2608
Hi	1907.6	Horizontal	-51.07	52.36	4.674	-46.396	121.91	69.55	23.154	33	-9.846
		Vertical	-51.07	50.64	4.32	-46.75	116.6	65.96	19.21	33	-13.79
WCDMA	HSUPA										
SubSet1	1852.4	Horizontal	-51.02	52.95	4.7285	-46.292	121.79	68.84	22.5485	33	-10.4515
		Vertical	-51.02	51.89	4.612	-46.408	120.11	68.22	21.812	33	-11.188
SubSet2	1852.4	Horizontal	-51.02	52.95	4.7285	-46.292	122.04	69.09	22.7985	33	-10.2015
		Vertical	-51.02	51.89	4.612	-46.408	120.25	68.36	21.952	33	-11.048
SubSet3	1852.4	Horizontal	-51.02	52.95	4.7285	-46.292	121.99	69.04	22.7485	33	-10.2515
		Vertical	-51.02	51.89	4.612	-46.408	119.8	67.91	21.502	33	-11.498
SubSet4	1852.4	Horizontal	-51.02	52.95	4.7285	-46.292	123.17	70.22	23.9285	33	-9.0715
		Vertical	-51.02	51.89	4.612	-46.408	120.47	68.58	22.172	33	-10.828
SubSet5	1852.4	Horizontal	-51.02	52.95	4.7285	-46.292	122.93	69.98	23.6885	33	-9.3115
		Vertical	-51.02	51.89	4.612	-46.408	120.35	68.46	22.052	33	-10.948
SubSet1	1880	Horizontal	-51.08	52.73	4.694	-46.386	123.53	70.8	24.414	33	-8.586
		Vertical	-51.08	50.56	4.4192	-46.661	119.33	68.77	22.1092	33	-10.8908
SubSet2	1880	Horizontal	-51.08	52.73	4.694	-46.386	123.62	70.89	24.504	33	-8.496
		Vertical	-51.08	50.56	4.4192	-46.661	119.14	68.58	21.9192	33	-11.0808
SubSet3	1880	Horizontal	-51.08	52.73	4.694	-46.386	123.09	70.36	23.974	33	-9.026
		Vertical	-51.08	50.56	4.4192	-46.661	118.37	67.81	21.1492	33	-11.8508
SubSet4	1880	Horizontal	-51.08	52.73	4.694	-46.386	124.33	71.6	25.214	33	-7.786
		Vertical	-51.08	50.56	4.4192	-46.661	119.35	68.79	22.1292	33	-10.8708
SubSet5	1880	Horizontal	-51.08	52.73	4.694	-46.386	123.42	70.69	24.304	33	-8.696
		Vertical	-51.08	50.56	4.4192	-46.661	119.01	68.45	21.7892	33	-11.2108
SubSet1	1907.6	Horizontal	-51.07	52.36	4.674	-46.396	122.4	70.04	23.644	33	-9.356
		Vertical	-51.07	50.64	4.32	-46.75	116.02	65.38	18.63	33	-14.37
SubSet2	1907.6	Horizontal	-51.07	52.36	4.674	-46.396	121.85	69.49	23.094	33	-9.906
		Vertical	-51.07	50.64	4.32	-46.75	115.99	65.35	18.6	33	-14.4
SubSet3	1907.6	Horizontal	-51.07	52.36	4.674	-46.396	121.31	68.95	22.554	33	-10.446
		Vertical	-51.07	50.64	4.32	-46.75	116.13	65.49	18.74	33	-14.26
SubSet4	1907.6	Horizontal	-51.07	52.36	4.674	-46.396	122.01	69.65	23.254	33	-9.746
		Vertical	-51.07	50.64	4.32	-46.75	116.29	65.65	18.9	33	-14.1
SubSet5	1907.6	Horizontal	-51.07	52.36	4.674	-46.396	122.06	69.7	23.304	33	-9.696
		Vertical	-51.07	50.64	4.32	-46.75	116.18	65.54	18.79	33	-14.21

7.2. FIELD STRENGTH OF SPURIOUS RADIATION

RULE PART(S)

FCC: §2.1053, §22.917, §24.238

IC: RSS-132, 4.5; RSS-133, 6.5

LIMIT

§22.917 (e) and §24.238 (a): Out of band emissions. The power of any emission outside of the authorized operating frequency ranges must be attenuated below the transmitting power (P) by a factor of at least $43 + 10 \log (P)$ dB

TEST PROCEDURE

For Cellular equipment - Compliance with these rules is based on the use of measurement instrumentation employing a resolution bandwidth of 100 kHz or greater. In the 1 MHz bands immediately outside and adjacent to the frequency block a resolution bandwidth of at least one percent of the emission bandwidth of the fundamental emission of the transmitter may be employed. A narrower resolution bandwidth is permitted in all cases to improve measurement accuracy provided the measured power is integrated over the full required measurement bandwidth (i.e. 100 kHz or 1 percent of emission bandwidth, as specified). The emission bandwidth is defined as the width of the signal between two points, one below the carrier center frequency and one above the carrier center frequency, outside of which all emissions are attenuated at least 26 dB below the transmitter power.

For PCS equipment - Compliance with these rules is based on the use of measurement instrumentation employing a resolution bandwidth of 1 MHz or greater. However, in the 1 MHz bands immediately outside and adjacent to the frequency block a resolution bandwidth of at least one percent of the emission bandwidth of the fundamental emission of the transmitter may be employed. A narrower resolution bandwidth is permitted in all cases to improve measurement accuracy provided the measured power is integrated over the full required measurement bandwidth (i.e. 1 MHz or 1 percent of emission bandwidth, as specified). The emission bandwidth is defined as the width of the signal between two points, one below the carrier center frequency and one above the carrier center frequency, outside of which all emissions are attenuated at least 26 dB below the transmitter power.

MODES TESTED:

- GPRS and EGPRS
- WCDMA

RESULTS

One mode per channel was used (GPRS) to determine any harmonics above noise floor. All harmonics found have a minimum margin of 17 dB or more to the -13dBm limit. Measurements at more than one mode were considered not necessary.

Lo CH (Cellular Band)

Description	Freq. MHz	Polarization	Voltage at antenna dBm	Substitution Peak Filed Strenght Measured dBuV/m	TX ant dBi	EIRP Level	ERP Level dBm	EUT Measured Peak Level dBuV/m	Delta EUT and Substitution dB	ERP EUT Level dBm	Limit dBm/MHz	Margin dB
GPRS Slot 1 Lo	824.2											
2nd Harmonic	1648.4	Horizontal	-53.62	52.15	6.032	-47.588	-49.738	67.52	15.37	-34.368104	-13	-21.3681
		Vertical	-53.62	50.69	6.125	-47.495	-49.645	61.32	10.63	-39.014904	-13	-26.0149
3rd Harmonic	2472.6	Horizontal	-54.57	47.14	5.722	-48.848	-50.998	59.68	12.54	-38.457508	-13	-25.4575
		Vertical	-54.57	47.71	5.651	-48.919	-51.069	61.5	13.79	-37.278846	-13	-24.2788
5th Harmonic	4121	Vertical	-56.16	49.7	8.977	-47.183	-49.333	43.78	-5.92	-55.25283	-13	-42.2528

Mid CH (Cellular Band)

Description	Freq. MHz	Polarization	Voltage at antenna dBm	Substitution Peak Filed Strenght Measured dBuV/m	TX ant dBi	EIRP Level	ERP Level dBm	EUT Measured Peak Level dBuV/m	Delta EUT and Substitution	ERP EUT Level dBm	Limit dBm/MHz	Margin dB
GPRS Slot 1 Mid	836.6											
2nd Harmonic	1673.2	Horizontal	-53.67	52.17	5.956	-47.714	-49.864	64.87	12.7	-37.163992	-13	-24.164
		Vertical	-53.67	50.6	6.062	-47.608	-49.758	60.28	9.68	-40.078392	-13	-27.0784
3rd Harmonic	2509.8	Horizontal	-54.49	46.87	5.743	-48.747	-50.897	57.25	10.38	-40.51669	-13	-27.5167
		Vertical	-54.49	47.91	5.646	-48.844	-50.994	56.87	8.96	-42.034168	-13	-29.0342
5th Harmonic	4183	Vertical	-56.29	51.33	9.087	-47.203	-49.353	43.08	-8.25	-57.60309	-13	-44.6031

Hi CH (Cellular Band)

Description	Freq. MHz	Polarization	Voltage at antenna dBm	Substitution Peak Filed Strenght Measured dBuV/m	TX ant dBi	EIRP Level	ERP Level dBm	EUT Measured Peak Level dBuV/m	Delta EUT and Substitution dB	ERP EUT Level dBm	Limit dBm/MHz	Margin dB
GPRS Slot 1 Hi	848.8											
2nd Harmonic	1697.6	Horizontal	-53.73	52.24	5.881	-47.849	-49.999	62.15	9.91	-40.088656	-13	-27.0887
		Vertical	-53.73	50.79	5.999	-47.731	-49.881	59.63	8.84	-41.040856	-13	-28.0409
3rd Harmonic	2546.4	Horizontal	-54.52	46.93	5.778	-48.742	-50.892	56.2	9.27	-41.62192	-13	-28.6219
		Vertical	-54.52	48.21	5.75	-48.77	-50.92	58.37	10.16	-40.760224	-13	-27.7602
5th Harmonic	4244	Vertical	-56.2	50.07	9.181	-47.019	-49.169	42.68	-7.39	-56.5592	-13	-43.5592

Lo CH (PCS Band)

Description	Freq. MHz	Polarization	Voltage at antenna dBm	Substitution Peak Filed Strenght Measured dBuV/m	TX ant dBi	EIRP Level	EUT Measured Peak Level dBuV/m	Delta EUT and Substitution dB	EIRP EUT Level dBm	Limit dBm/MHz	Margin dB
GPRS Slot 1 Lo	1850.2										
3rd Harmonic	5550.6	Horizontal	-44.3	59.62	10.19	-34.111	51.98	-7.64	-41.750566	-13	-28.7506
		Vertical	-44.3	61.01	10.15	-34.149	49.61	-11.4	-45.549026	-13	-32.549
4th Harmonic	7400.8	Horizontal	-45.18	60.35	11.86	-33.322	42.43	-17.92	-51.241688	-13	-38.2417
		Vertical	-45.18	62.51	11.81	-33.371	48.14	-14.37	-47.741072	-13	-34.7411

Mid CH (PCS Band)

Description	Freq. MHz	Polarization	Voltage at antenna dBm	Substitution Peak Filed Strenght Measured dBuV/m	TX ant dBi	EIRP Level	EUT Measured Peak Level dBuV/m	Delta EUT and Substitution dB	EIRP EUT Level dBm	Limit dBm/MHz	Margin dB
GPRS Slot 1 Mid	1880										
3rd Harmonic	5640	Horizontal	-51.69	54.01	10.14	-41.546	52.8	-1.21	-42.7564	-13	-29.7564
		Vertical	-51.69	54.69	10.2	-41.489	50.74	-3.95	-45.4388	-13	-32.4388

HI CH (PCS Band)

Description	Freq. MHz	Polarization	Voltage at antenna dBm	Substitution Peak Filed Strenght Measured dBuV/m	TX ant dBi	EIRP Level	EUT Measured Peak Level dBuV/m	Delta EUT and Substitution dB	EIRP EUT Level dBm	Limit dBm/MHz	Margin dB
GPRS Slot 1 Hi	1909.8										
3rd Harmonic	5729.4	Horizontal	-44.42	59.95	10.09	-34.328	44.74	-15.21	-49.538474	-13	-36.5385
		Vertical	-44.42	60.62	10.23	-34.191	46.63	-13.99	-48.180828	-13	-35.1808