



FCC TEST REPORT (15.407)

REPORT NO.: RF120503C13B-1
MODEL NO.: TP00042A
FCC ID: GKR-TP00042ABR
RECEIVED: May 03, 2012
TESTED: May 09 ~ Aug. 13, 2012
ISSUED: Aug. 22, 2012

APPLICANT: COMPAL ELECTRONICS, INC.

ADDRESS: No.581, Ruiguang Rd., Neihu District, Taipei City
11492, Taiwan (R.O.C.)

ISSUED BY: Bureau Veritas Consumer Products Services
(H.K.) Ltd., Taoyuan Branch

LAB ADDRESS: No. 47, 14th Ling, Chia Pau Vil., Lin Kou Dist.,
New Taipei City, Taiwan (R.O.C.)

TEST LOCATION: No. 19, Hwa Ya 2nd Rd, Wen Hwa Tsuen, Kwei
Shan Hsiang, Taoyuan Hsien 333, Taiwan, R.O.C.

This report should not be used by the client to claim product certification, approval, or endorsement by TAF or any government agencies.



This report is for your exclusive use. Any copying or replication of this report to or for any other person or entity, or use of our name or trademark, is permitted only with our prior written permission. This report sets forth our findings solely with respect to the test samples identified herein. The results set forth in this report are not indicative or representative of the quality or characteristics of the lot from which a test sample was taken or any similar or identical product unless specifically and expressly noted. Our report includes all of the tests requested by you and the results thereof based upon the information that you provided to us. You have 60 days from date of issuance of this report to notify us of any material error or omission caused by our negligence, provided, however, that such notice shall be in writing and shall specifically address the issue you wish to raise. A failure to raise such issue within the prescribed time shall constitute your unqualified acceptance of the completeness of this report, the tests conducted and the correctness of the report contents. Unless specific mention, the uncertainty of measurement has been explicitly taken into account to declare the compliance or non-compliance to the specification.

TABLE OF CONTENTS

RELEASE CONTROL RECORD	4
1. CERTIFICATION.....	5
2. SUMMARY OF TEST RESULTS.....	6
2.1 MEASUREMENT UNCERTAINTY	6
3. GENERAL INFORMATION	7
3.1 GENERAL DESCRIPTION OF EUT.....	7
3.2 DESCRIPTION OF TEST MODES.....	9
3.2.1 TEST MODE APPLICABILITY AND TESTED CHANNEL DETAIL.....	10
3.3 DUTY CYCLE OF TEST SIGNAL.....	12
3.4 DESCRIPTION OF SUPPORT UNITS	13
3.4.1 CONFIGURATION OF SYSTEM UNDER TEST	13
3.5 GENERAL DESCRIPTION OF APPLIED STANDARDS.....	14
4. TEST TYPES AND RESULTS.....	15
4.1 RADIATED EMISSION AND BANDEDGE MEASUREMENT	15
4.1.1 LIMITS OF RADIATED EMISSION AND BANDEDGE MEASUREMENT	15
4.1.2 LIMITS OF UNWANTED EMISSION OUT OF THE RESTRICTED BANDS	15
4.1.3 TEST INSTRUMENTS	16
4.1.4 TEST PROCEDURES.....	17
4.1.5 DEVIATION FROM TEST STANDARD	17
4.1.6 TEST SETUP.....	18
4.1.7 EUT OPERATING CONDITION	18
4.1.8 TEST RESULTS.....	19
4.2 CONDUCTED EMISSION MEASUREMENT	62
4.2.1 LIMITS OF CONDUCTED EMISSION MEASUREMENT	62
4.2.2 TEST INSTRUMENTS	62
4.2.3 TEST PROCEDURES.....	63
4.2.4 DEVIATION FROM TEST STANDARD	63
4.2.5 TEST SETUP.....	63
4.2.6 EUT OPERATING CONDITIONS.....	63
4.2.7 TEST RESULTS.....	64
4.3 PEAK TRANSMIT POWER MEASUREMENT	68
4.3.1 LIMITS OF PEAK TRANSMIT POWER MEASUREMENT	68
4.3.2 TEST SETUP.....	68
4.3.3 TEST INSTRUMENTS	68
4.3.4 TEST PROCEDURE	69
4.3.5 DEVIATION FROM TEST STANDARD	69
4.3.6 EUT OPERATING CONDITIONS.....	69
4.3.7 TEST RESULTS.....	70
4.4 PEAK POWER SPECTRAL DENSITY MEASUREMENT.....	74
4.4.1 LIMITS OF PEAK POWER SPECTRAL DENSITY MEASUREMENT	74
4.4.2 TEST SETUP.....	74
4.4.3 TEST INSTRUMENTS	74
4.4.4 TEST PROCEDURES.....	75
4.4.5 DEVIATION FROM TEST STANDARD	75
4.4.6 EUT OPERATING CONDITIONS.....	75
4.4.7 TEST RESULTS.....	76
4.5 PEAK POWER EXCURSION MEASUREMENT	78



A D T

4.5.1	LIMITS OF PEAK POWER EXCURSION MEASUREMENT	78
4.5.2	TEST SETUP	78
4.5.3	TEST INSTRUMENTS	78
4.5.4	TEST PROCEDURE	78
4.5.5	DEVIATION FROM TEST STANDARD	78
4.5.6	EUT OPERATING CONDITIONS	78
4.5.7	TEST RESULTS.....	79
4.6	FREQUENCY STABILITY	84
4.6.1	LIMITS OF FREQUENCY STABILITY MEASUREMENT	84
4.6.2	TEST SETUP	84
4.6.3	TEST INSTRUMENTS	84
4.6.4	TEST PROCEDURE	85
4.6.5	DEVIATION FROM TEST STANDARD	85
4.6.6	EUT OPERATING CONDITION	85
4.6.7	TEST RESULTS.....	86
5.	PHOTOGRAPHS OF THE TEST CONFIGURATION	87
6.	INFORMATION ON THE TESTING LABORATORIES	88
7.	APPENDIX A - MODIFICATIONS RECORDERS FOR ENGINEERING CHANGES TO THE EUT BY THE LAB	89



A D T

RELEASE CONTROL RECORD

ISSUE NO.	REASON FOR CHANGE	DATE ISSUED
RF120503C13B-1	Original release	Aug. 22, 2012



1. CERTIFICATION

PRODUCT: Convertible Tablet Computer
MODEL NO.: TP00042A
BRAND: Lenovo
APPLICANT: COMPAL ELECTRONICS, INC.
TESTED: May 09 ~ Aug. 13, 2012
TEST SAMPLE: ENGINEERING SAMPLE
STANDARDS: **FCC Part 15, Subpart E (Section 15.407)**
ANSI C63.10-2009

The above equipment (model: TP00042A) has been tested by **Bureau Veritas Consumer Products Services (H.K.) Ltd., Taoyuan Branch**, and found compliance with the requirement of the above standards. The test record, data evaluation & Equipment Under Test (EUT) configurations represented herein are true and accurate accounts of the measurements of the sample's EMC characteristics under the conditions specified in this report.

PREPARED BY : Ivonne Wu , **DATE** : Aug. 22, 2012
Ivonne Wu / Senior Specialist

APPROVED BY : Gary Chang , **DATE** : Aug. 22, 2012
Gary Chang / Technical Manager

2. SUMMARY OF TEST RESULTS

The EUT has been tested according to the following specifications:

APPLIED STANDARD: FCC PART 15, SUBPART E (SECTION 15.407)			
STANDARD SECTION	TEST TYPE	RESULT	REMARK
15.407(b)(6)	AC Power Conducted Emission	PASS	Meet the requirement of limit. Minimum passing margin is -16.91dB at 0.38438MHz.
15.407(b/1/2/3) (b)(6)	Spurious Emissions	PASS	Meet the requirement of limit. Minimum passing margin is -1.1dB at 5150.00MHz.
15.407(a/1/2)	Peak Transmit Power	PASS	Meet the requirement of limit.
15.407(a)(6)	Peak Power Excursion	PASS	Meet the requirement of limit.
15.407(a/1/2)	Peak Power Spectral Density	PASS	Meet the requirement of limit.
15.407(g)	Frequency Stability	PASS	Meet the requirement of limit.
15.203	Antenna Requirement	PASS	Antenna connector is I-PEX

2.1 MEASUREMENT UNCERTAINTY

Where relevant, the following measurement uncertainty levels have been estimated for tests performed on the EUT as specified in CISPR 16-4-2:

MEASUREMENT	FREQUENCY	UNCERTAINTY
Conducted emissions	9kHz~30MHz	2.44 dB
Radiated emissions	30MHz ~ 200MHz	2.93 dB
	200MHz ~1000MHz	2.95 dB
	1GHz ~ 18GHz	2.26 dB
	18GHz ~ 40GHz	1.94 dB

This uncertainty represents an expanded uncertainty expressed at approximately the 95% confidence level using a coverage factor of $k = 2$.

3. GENERAL INFORMATION

3.1 GENERAL DESCRIPTION OF EUT

EUT	Convertible Tablet Computer
MODEL NO.	TP00042A
MODULE MODEL NO.	BCM943228HMB
POWER SUPPLY	20Vdc from adapter
MODULATION TYPE	64QAM, 16QAM, QPSK, BPSK
MODULATION TECHNOLOGY	OFDM
TRANSFER RATE	802.11a: 54.0/ 48.0/ 36.0/ 24.0/ 18.0/ 12.0/ 9.0/ 6.0Mbps 802.11n: up to 300.0Mbps
OPERATING FREQUENCY	5180 ~ 5240MHz, 5260 ~ 5320MHz & 5500 ~ 5700MHz
NUMBER OF CHANNEL	5180 ~ 5240MHz: 4 for 802.11a, 802.11n (20MHz) 2 for 802.11n (40MHz) 5260 ~ 5320MHz: 4 for 802.11a, 802.11n (20MHz) 2 for 802.11n (40MHz) 5500 ~ 5700MHz: 8 for 802.11a, 802.11n (20MHz) 5 for 802.11n (40MHz)
OUTPUT POWER	33.7mW for 5180 ~ 5240MHz 42.0mW for 5260 ~ 5320MHz 42.5mW for 5500 ~ 5700MHz
ANTENNA TYPE	Refer to NOTE as below
ANTENNA CONNECTOR	NA
DATA CABLE	NA
I/O PORTS	Refer to user's manual
ACCESSORY DEVICES	Adapter

NOTE:

- The EUT incorporates a MIMO function. Physically, the EUT provides two completed transmitters and two receivers.

MODULATION MODE	TX FUNCTION
802.11b	1TX
802.11g	1TX
802.11a	1TX
802.11n (20MHz)	1TX / 2TX
802.11n (40MHz)	1TX / 2TX



2. The antenna information is listed as below.

	JPC Antenna (1st)		WNC Antenna (2nd)	
Antenna Type	PIFA		PIFA	
Manufacturer	Jess-Link Product Co., LTD		Wistron Neweb Corp.	
Model Name	Antenna Type	Model name	Antenna Type	Model name
	WLAN MAIN L	PANT11A00034-1	WLAN MAIN L	81.EG915.G34
	WLAN AUX R	PANT11A00035-1	WLAN AUX R	81.EG915.G35
Antenna Gain	WLAN Main		WLAN Main	
	2.4~2.4835 GHz	-2.03	2.4~2.4835 GHz	-0.54
	5.15~5.25 GHz	-0.59	5.15~5.25 GHz	0.12
	5.25~5.35 GHz	-1.56	5.25~5.35 GHz	-0.41
	5.47~5.725 GHz	0.21	5.47~5.725 GHz	0.86
	5.725~5.85 GHz	0.45	5.725~5.85 GHz	0.86
	WLAN Aux.		WLAN Aux.	
	2.4~2.4835 GHz	-3.47	2.4~2.4835 GHz	-1.09
	5.15~5.25 GHz	-0.13	5.15~5.25 GHz	0.91
	5.25~5.35 GHz	-0.07	5.25~5.35 GHz	0.91
	5.47~5.725 GHz	-0.08	5.47~5.725 GHz	1.23
5.725~5.85 GHz	0.42	5.725~5.85 GHz	1.23	

3. The EUT consumes power from the following adapter.

ADAPTER	
BRAND:	Lenovo
MODEL:	45N0185
INPUT:	100-240Vac, 50-60Hz, 1.5A
OUTPUT:	20Vdc, 3.25A
POWER LINE:	1.8m non-shielded cable with one core

4. The above EUT information is declared by manufacturer and for more detailed features description, please refer to the manufacturer's specifications or user's manual.

3.2 DESCRIPTION OF TEST MODES

FOR 5180 ~ 5240MHz

4 channels are provided for 802.11a, 802.11n (20MHz):

CHANNEL	FREQUENCY	CHANNEL	FREQUENCY
36	5180 MHz	44	5220 MHz
40	5200 MHz	48	5240 MHz

2 channels are provided for 802.11n (40MHz):

CHANNEL	FREQUENCY	CHANNEL	FREQUENCY
38	5190 MHz	46	5230 MHz

FOR 5260 ~ 5320MHz

4 channels are provided for 802.11a, 802.11n (20MHz):

CHANNEL	FREQUENCY	CHANNEL	FREQUENCY
52	5260 MHz	60	5300 MHz
56	5280 MHz	64	5320 MHz

2 channels are provided for 802.11n (40MHz):

CHANNEL	FREQUENCY	CHANNEL	FREQUENCY
54	5270 MHz	62	5310 MHz

FOR 5500 ~ 5700MHz

11 channels are provided for 802.11a, 802.11n (20MHz):

CHANNEL	FREQUENCY	CHANNEL	FREQUENCY
100	5500 MHz	124	5620 MHz
104	5520 MHz	128	5640 MHz
108	5540 MHz	132	5660 MHz
112	5560 MHz	136	5680 MHz
116	5580 MHz	140	5700 MHz
120	5600 MHz		

5 channels are provided for 802.11n (40MHz):

CHANNEL	FREQUENCY	CHANNEL	FREQUENCY
102	5510MHz	126	5630MHz
110	5550MHz	134	5670MHz
118	5590MHz		

3.2.1 TEST MODE APPLICABILITY AND TESTED CHANNEL DETAIL

EUT CONFIGURE MODE	APPLICABLE TO				DESCRIPTION
	RE \geq 1G	RE<1G	PLC	APCM	
-	√	√	√	√	-

Where **RE \geq 1G**: Radiated Emission above 1GHz **RE<1G**: Radiated Emission below 1GHz
PLC: Power Line Conducted Emission **APCM**: Antenna Port Conducted Measurement

RADIATED EMISSION TEST (ABOVE 1GHz):

- Pre-Scan has been conducted to determine the worst-case mode from all possible combinations between available modulations, data rates and antenna ports (if EUT with antenna diversity architecture).
- Following channel(s) was (were) selected for the final test as listed below.

MODE	FREQ. BAND (MHz)	AVAILABLE CHANNEL	TESTED CHANNEL	MODULATION TECHNOLOGY	MODULATION TYPE	DATA RATE (Mbps)	TX Function
802.11a	5180-5240	36 to 48	36, 40, 48	OFDM	BPSK	6.0	1TX
802.11n (20MHz)		36 to 48	36, 40, 48	OFDM	BPSK	7.2	1TX
802.11n (40MHz)		38 to 46	38, 46	OFDM	BPSK	15.0	1TX
802.11n (20MHz)		36 to 48	36, 40, 48	OFDM	BPSK	14.4	2TX
802.11n (40MHz)		38 to 46	38, 46	OFDM	BPSK	30.0	2TX
802.11a	5260-5320	52 to 64	52, 60, 64	OFDM	BPSK	6.0	1TX
802.11n (20MHz)		52 to 64	52, 60, 64	OFDM	BPSK	7.2	1TX
802.11n (40MHz)		54 to 62	54, 62	OFDM	BPSK	15.0	1TX
802.11n (20MHz)		52 to 64	52, 60, 64	OFDM	BPSK	14.4	2TX
802.11n (40MHz)		54 to 62	54, 62	OFDM	BPSK	30.0	2TX
802.11a	5500-5700	100 to 140	100, 116, 140	OFDM	BPSK	6.0	1TX
802.11n (20MHz)		100 to 140	100, 116, 140	OFDM	BPSK	7.2	1TX
802.11n (40MHz)		102 to 134	102, 110, 134	OFDM	BPSK	15.0	1TX
802.11n (20MHz)		100 to 140	100, 116, 140	OFDM	BPSK	14.4	2TX
802.11n (40MHz)		102 to 134	102, 110, 134	OFDM	BPSK	30.0	2TX

RADIATED EMISSION TEST (BELOW 1GHz):

- Pre-Scan has been conducted to determine the worst-case mode from all possible combinations between available modulations, data rates and antenna ports (if EUT with antenna diversity architecture).
- Following channel(s) was (were) selected for the final test as listed below.

MODE	FREQ. BAND (MHz)	AVAILABLE CHANNEL	TESTED CHANNEL	MODULATION TECHNOLOGY	MODULATION TYPE	DATA RATE (Mbps)	TX Function
802.11n (20MHz)	5180-5320	38 to 64	52	OFDM	BPSK	14.4	2TX
802.11n (20MHz)	5500-5700	100 to 140	100	OFDM	BPSK	14.4	2TX

POWER LINE CONDUCTED EMISSION TEST:

- Pre-Scan has been conducted to determine the worst-case mode from all possible combinations between available modulations, data rates and antenna ports (if EUT with antenna diversity architecture).
- Following channel(s) was (were) selected for the final test as listed below.

MODE	FREQ. BAND (MHz)	AVAILABLE CHANNEL	TESTED CHANNEL	MODULATION TECHNOLOGY	MODULATION TYPE	DATA RATE (Mbps)	TX Function
802.11n (20MHz)	5180-5320	38 to 64	52	OFDM	BPSK	14.4	2TX
802.11n (20MHz)	5500-5700	100 to 140	100	OFDM	BPSK	14.4	2TX

ANTENNA PORT CONDUCTED MEASUREMENT:

- This item includes all test value of each mode, but only includes spectrum plot of worst value of each mode.
- Pre-Scan has been conducted to determine the worst-case mode from all possible combinations between available modulations, data rates and antenna ports (if EUT with antenna diversity architecture).
- Following channel(s) was (were) selected for the final test as listed below.

MODE	FREQ. BAND (MHz)	AVAILABLE CHANNEL	TESTED CHANNEL	MODULATION TECHNOLOGY	MODULATION TYPE	DATA RATE (Mbps)	TX Function
802.11a	5180-5240	36 to 48	36, 40, 48	OFDM	BPSK	6.0	1TX
802.11n (20MHz)		36 to 48	36, 40, 48	OFDM	BPSK	7.2	1TX
802.11n (40MHz)		38 to 46	38, 46	OFDM	BPSK	15.0	1TX
802.11n (20MHz)		36 to 48	36, 40, 48	OFDM	BPSK	14.4	2TX
802.11n (40MHz)		38 to 46	38, 46	OFDM	BPSK	30.0	2TX
802.11a	5260-5320	52 to 64	52, 60, 64	OFDM	BPSK	6.0	1TX
802.11n (20MHz)		52 to 64	52, 60, 64	OFDM	BPSK	7.2	1TX
802.11n (40MHz)		54 to 62	54, 62	OFDM	BPSK	15.0	1TX
802.11n (20MHz)		52 to 64	52, 60, 64	OFDM	BPSK	14.4	2TX
802.11n (40MHz)		54 to 62	54, 62	OFDM	BPSK	30.0	2TX
802.11a	5500-5700	100 to 140	100, 116, 140	OFDM	BPSK	6.0	1TX
802.11n (20MHz)		100 to 140	100, 116, 140	OFDM	BPSK	7.2	1TX
802.11n (40MHz)		102 to 134	102, 110, 134	OFDM	BPSK	15.0	1TX
802.11n (20MHz)		100 to 140	100, 116, 140	OFDM	BPSK	14.4	2TX
802.11n (40MHz)		102 to 134	102, 110, 134	OFDM	BPSK	30.0	2TX

TEST CONDITION:

APPLICABLE TO	ENVIRONMENTAL CONDITIONS	INPUT POWER	TESTED BY
RE≥1G	21deg. C, 68%RH	120Vac, 60Hz	Chad Lee
RE<1G	25deg. C, 89%RH	120Vac, 60Hz	Chad Lee
PLC	25deg. C, 65%RH	120Vac, 60Hz	Brad Wu
APCM	21deg. C, 68%RH	120Vac, 60Hz	Brad Wu

3.3 DUTY CYCLE OF TEST SIGNAL

802.11a:

Duty cycle = $(2.064 + 10.664) / 12.732 = 0.999$

Duty cycle of test signal is 99.9 % > 98 %, duty factor is not required.

802.11n (20MHz): 1TX

Duty cycle = $11.76 / 11.92 = 0.987$

Duty cycle of test signal is 98.7 % > 98 %, duty factor is not required.

802.11n (40MHz): 1TX

Duty cycle = $5.79 / 6.03 = 0.960$, Duty factor = $10 * \log(1/0.960) = 0.18$

802.11n (20MHz): 2TX

Duty cycle = $6.04 / 6.28 = 0.962$, Duty factor = $10 * \log(1/0.962) = 0.17$

802.11n (40MHz): 2TX

Duty cycle = $3.00 / 3.38 = 0.888$, Duty factor = $10 * \log(1/0.888) = 0.52$

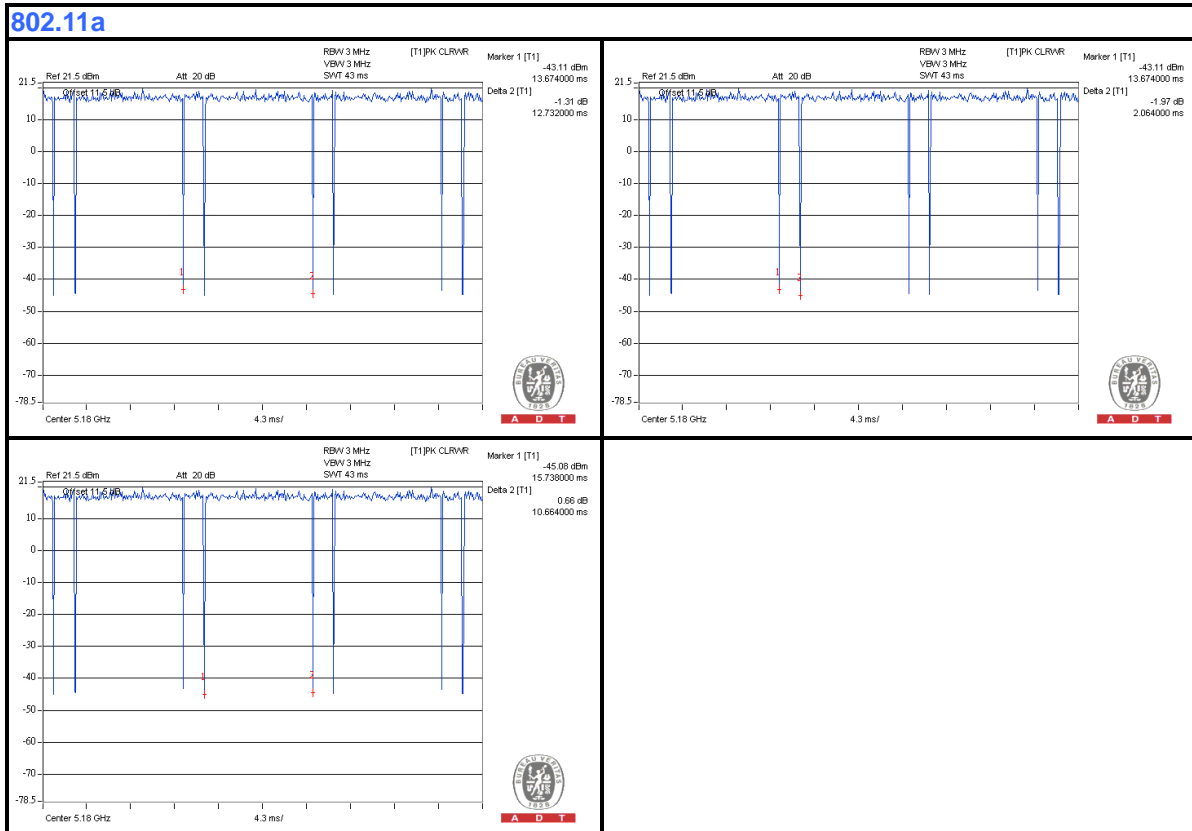

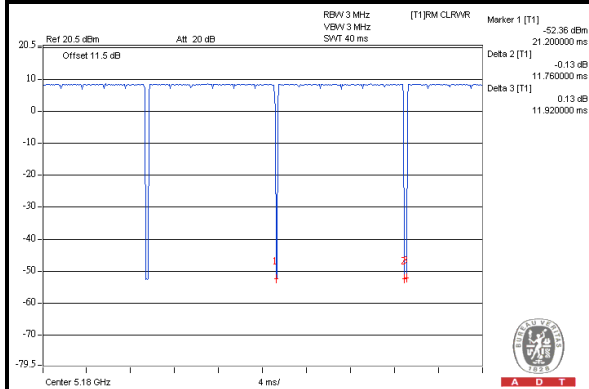
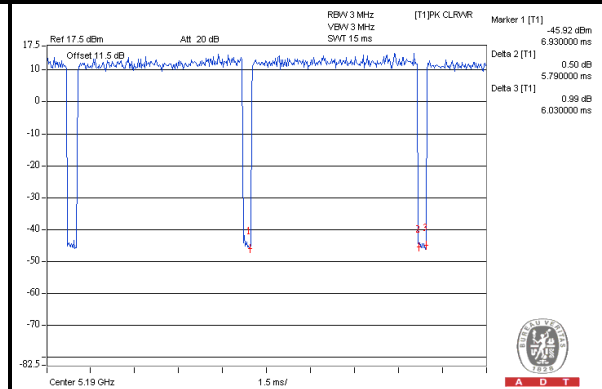
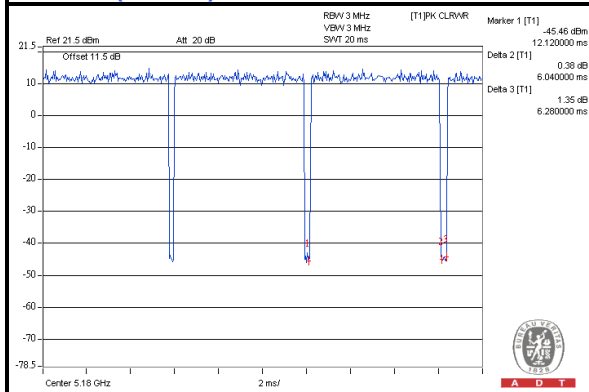
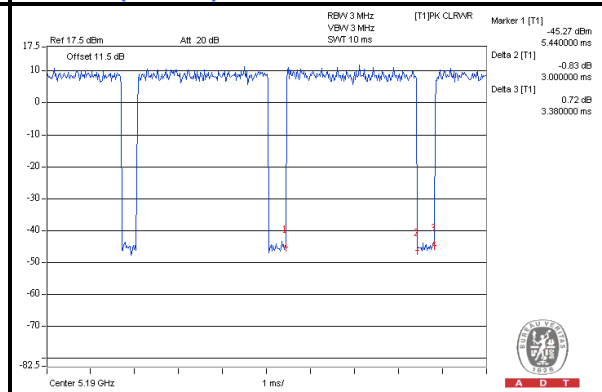
802.11n (20MHz): 1TX

802.11n (40MHz): 1TX

802.11n (20MHz): 2TX

802.11n (40MHz): 2TX

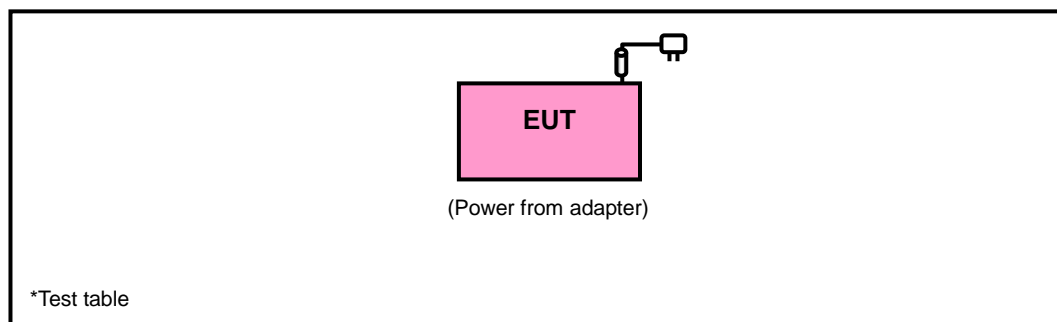
3.4 DESCRIPTION OF SUPPORT UNITS

The EUT has been tested as an independent unit together with other necessary accessories or support units.

3.4.1 CONFIGURATION OF SYSTEM UNDER TEST





3.5 GENERAL DESCRIPTION OF APPLIED STANDARDS

The EUT is a RF Product. According to the specifications of the manufacturer, it must comply with the requirements of the following standards:

FCC Part 15, Subpart E (15.407)

ANSI C63.10-2009

KDB 789033 D01 General UNII Test Procedures v01r01

All test items have been performed and recorded as per the above standards.

NOTE: The EUT is also considered as a kind of computer peripheral, because the connection to computer is necessary for typical use. It has been verified to comply with the requirements of FCC Part 15, Subpart B, Class B (DoC). The test report has been issued separately.

4. TEST TYPES AND RESULTS

4.1 RADIATED EMISSION AND BANDEDGE MEASUREMENT

4.1.1 LIMITS OF RADIATED EMISSION AND BANDEDGE MEASUREMENT

Radiated emissions which fall in the restricted bands must comply with the radiated emission limits specified as below table:

FREQUENCIES (MHz)	FIELD STRENGTH (microvolts/meter)	MEASUREMENT DISTANCE (meters)
0.009 ~ 0.490	2400/F(kHz)	300
0.490 ~ 1.705	24000/F(kHz)	30
1.705 ~ 30.0	30	30
30 ~ 88	100	3
88 ~ 216	150	3
216 ~ 960	200	3
Above 960	500	3

NOTE:

1. The lower limit shall apply at the transition frequencies.
2. Emission level (dBuV/m) = 20 log Emission level (uV/m).
3. For frequencies above 1000MHz, the field strength limits are based on average detector, however, the peak field strength of any emission shall not exceed the maximum permitted average limits, specified above by more than 20dB under any condition of modulation.

4.1.2 LIMITS OF UNWANTED EMISSION OUT OF THE RESTRICTED BANDS

EIRP LIMIT (dBm)	EQUIVALENT FIELD STRENGTH AT 3m (dBμV/m)
PK	PK
-27	68.3

NOTE: The following formula is used to convert the equipment isotropic radiated power (eirp) to field strength:

$$E = \frac{1000000 \sqrt{30P}}{3} \mu\text{V/m, where P is the eirp (Watts).}$$

4.1.3 TEST INSTRUMENTS

DESCRIPTION & MANUFACTURER	MODEL NO.	SERIAL NO.	DATE OF CALIBRATION	DUE DATE OF CALIBRATION
Test Receiver ROHDE & SCHWARZ	ESIB7	100186	Nov. 29, 2011	Nov. 28, 2012
Spectrum Analyzer ROHDE & SCHWARZ	FSP 40	100037	Nov. 02, 2011	Nov. 01, 2012
BILOG Antenna SCHWARZBECK	VULB9168	9168-157	Apr. 02, 2012	Apr. 01, 2013
RF signal cable Woken	8D-FB	N/A	Mar. 24, 2012	Mar. 23, 2013
HORN Antenna SCHWARZBECK	BBHA 9120 D *	9120D-405	Feb. 03, 2012	Feb. 02, 2013
HORN Antenna SCHWARZBECK	BBHA 9170	BBHA9170243	Jan. 03, 2012	Jan. 02, 2013
Loop Antenna	HFH2-Z2	100070	Jan. 31, 2012	Jan. 30, 2014
Preamplifier Agilent (Below 1GHz)	8447D	2944A10629	Oct. 29, 2011	Oct. 28, 2012
Preamplifier Agilent (Above 1GHz)	8449B	3008A01959	Oct. 29, 2011	Oct. 28, 2012
RF signal cable HUBER+SUHNER	SUCOFLEX 104	230132/4	Nov. 03, 2011	Nov. 02, 2012
RF signal cable HUBER+SUHNER	SUCOFLEX 104	309223/4+309218 /4	Nov. 03, 2011	Nov. 02, 2012
Software ADT	BV ADT_Radiated_ V7.6.15.9.3	NA	NA	NA
Antenna Tower ADT	AT100	AT93021702	NA	NA
Turn Table ADT	TT100	TT93021702	NA	NA
Controller ADT	SC100	SC93021702	NA	NA
Fix tool for Boresight antenna tower	BAF-01	2	NA	NA
26GHz ~ 40GHz Amplifier	EM26400	815221	Oct. 29, 2011	Oct. 28, 2012

- NOTE:** 1. The calibration interval of the above test instruments is 12 months and the calibrations are traceable to NML/ROC and NIST/USA.
2. The calibration interval of the loop antenna is 24 months and the calibrations are traceable to NML/ROC and NIST/USA.
3. The test was performed in HwaYa Chamber 2.
4. The horn antenna and HP preamplifier (model: 8449B) are used only for the measurement of emission frequency above 1GHz if tested.
5. The FCC Site Registration No. is 686814.
6. The IC Site Registration No. is IC7450F-2.

4.1.4 TEST PROCEDURES

- a. The EUT was placed on the top of a rotating table 0.8 meters above the ground at a 3 meter semi-anechoic chamber. The table was rotated 360 degrees to determine the position of the highest radiation.
- b. The EUT was set 3 meters away from the interference-receiving antenna, which was mounted on the top of a variable-height antenna tower.
- c. The antenna is a broadband antenna, and its height is varied from one meter to four meters above the ground to determine the maximum value of the field strength. Both horizontal and vertical polarizations of the antenna are set to make the measurement.
- d. For each suspected emission, the EUT was arranged to its worst case and then the antenna was tuned to heights from 1 meter to 4 meters and the rotatable table was turned from 0 degrees to 360 degrees to find the maximum reading.
- e. The test-receiver system was set to Peak Detect Function and Specified Bandwidth with Maximum Hold Mode.
- f. If the emission level of the EUT in peak mode was 10dB lower than the limit specified, then testing could be stopped and the peak values of the EUT would be reported. Otherwise the emissions that did not have 10dB margin would be re-tested one by one using peak, quasi-peak or average method as specified and then reported in a data sheet.

NOTE:

1. The resolution bandwidth and video bandwidth of test receiver/spectrum analyzer is 120kHz for Peak detection (PK) and Quasi-peak detection (QP) at frequency below 1GHz.
2. The resolution bandwidth of test receiver/spectrum analyzer is 1MHz and video bandwidth is 3MHz for Peak detection at frequency above 1GHz.
3. The resolution bandwidth of test receiver/spectrum analyzer is 1MHz and the video bandwidth is 1kHz for Average detection (AV) at frequency above 1GHz.
4. All modes of operation were investigated and the worst-case emissions are reported.

4.1.5 DEVIATION FROM TEST STANDARD

No deviation.

4.1.6 TEST SETUP

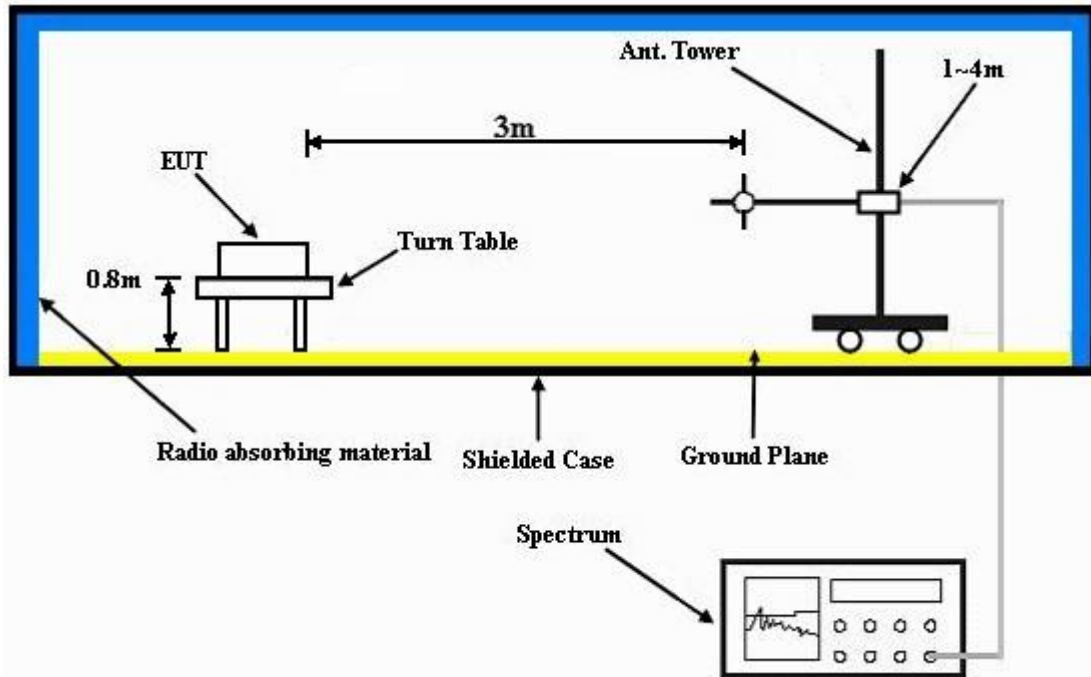

For the actual test configuration, please refer to the attached file (Test Setup Photo).

4.1.7 EUT OPERATING CONDITION

- a. Placed the EUT on a testing table.
- b. Use the software to control the EUT under transmission condition continuously at specific channel frequency.

4.1.8 TEST RESULTS

ABOVE 1GHz DATA:

802.11a: 1TX

EUT TEST CONDITION		MEASUREMENT DETAIL	
CHANNEL	Channel 36	FREQUENCY RANGE	1 ~ 40GHz
INPUT POWER (SYSTEM)	120Vac, 60 Hz	DETECTOR FUNCTION	Peak (PK) Average (AV)
ENVIRONMENTAL CONDITIONS	21deg. C, 68%RH	TESTED BY	Chad Lee

ANTENNA POLARITY & TEST DISTANCE: HORIZONTAL AT 3 M								
NO.	FREQ. (MHz)	EMISSION LEVEL (dBuV/m)	LIMIT (dBuV/m)	MARGIN (dB)	ANTENNA HEIGHT (m)	TABLE ANGLE (Degree)	RAW VALUE (dBuV)	CORRECTION FACTOR (dB/m)
1	5150.00	51.9 PK	74.0	-22.1	1.02 H	307	14.53	37.37
2	5150.00	40.8 AV	54.0	-13.3	1.02 H	307	3.38	37.37
3	*5180.00	103.8 PK			1.02 H	307	66.38	37.41
4	*5180.00	91.1 AV			1.02 H	307	53.65	37.41
5	#10360.00	56.0 PK	68.3	-12.3	1.02 H	6	8.74	47.25
ANTENNA POLARITY & TEST DISTANCE: VERTICAL AT 3 M								
NO.	FREQ. (MHz)	EMISSION LEVEL (dBuV/m)	LIMIT (dBuV/m)	MARGIN (dB)	ANTENNA HEIGHT (m)	TABLE ANGLE (Degree)	RAW VALUE (dBuV)	CORRECTION FACTOR (dB/m)
1	5150.00	50.4 PK	74.0	-23.6	1.00 V	149	12.99	37.37
2	5150.00	38.3 AV	54.0	-15.8	1.00 V	149	0.88	37.37
3	*5180.00	106.2 PK			1.00 V	149	68.83	37.41
4	*5180.00	93.6 AV			1.00 V	149	56.22	37.41
5	#10360.00	56.5 PK	68.3	-11.8	1.00 V	16	9.21	47.25

REMARKS:

1. Emission level (dBuV/m) = Raw Value (dBuV) + Correction Factor (dB/m).
2. Correction Factor (dB/m) = Antenna Factor (dB/m) + Cable Factor (dB).
3. The other emission levels were very low against the limit.
4. Margin value = Emission level – Limit value.
5. " * ": Fundamental frequency.
6. "#":The radiated frequency is out the restricted band.



A D T

EUT TEST CONDITION		MEASUREMENT DETAIL	
CHANNEL	Channel 40	FREQUENCY RANGE	1 ~ 40GHz
INPUT POWER (SYSTEM)	120Vac, 60 Hz	DETECTOR FUNCTION	Peak (PK) Average (AV)
ENVIRONMENTAL CONDITIONS	21deg. C, 68%RH	TESTED BY	Chad Lee

ANTENNA POLARITY & TEST DISTANCE: HORIZONTAL AT 3 M								
NO.	FREQ. (MHz)	EMISSION LEVEL (dBuV/m)	LIMIT (dBuV/m)	MARGIN (dB)	ANTENNA HEIGHT (m)	TABLE ANGLE (Degree)	RAW VALUE (dBuV)	CORRECTION FACTOR (dB/m)
1	*5200.00	103.4 PK			1.00 H	316	65.99	37.43
2	*5200.00	91.1 AV			1.00 H	316	53.69	37.43
3	#10400.00	55.6 PK	68.3	-12.7	1.00 H	28	8.32	47.31
ANTENNA POLARITY & TEST DISTANCE: VERTICAL AT 3 M								
NO.	FREQ. (MHz)	EMISSION LEVEL (dBuV/m)	LIMIT (dBuV/m)	MARGIN (dB)	ANTENNA HEIGHT (m)	TABLE ANGLE (Degree)	RAW VALUE (dBuV)	CORRECTION FACTOR (dB/m)
1	*5200.00	106.5 PK			1.00 V	158	69.09	37.43
2	*5200.00	94.1 AV			1.00 V	158	56.69	37.43
3	#10400.00	57.4 PK	68.3	-10.9	1.00 V	144	10.05	47.31

REMARKS:

1. Emission level (dBuV/m) = Raw Value (dBuV) + Correction Factor (dB/m).
2. Correction Factor (dB/m) = Antenna Factor (dB/m) + Cable Factor (dB).
3. The other emission levels were very low against the limit.
4. Margin value = Emission level – Limit value.
5. “ * “: Fundamental frequency.
6. “#”:The radiated frequency is out the restricted band.



A D T

EUT TEST CONDITION		MEASUREMENT DETAIL	
CHANNEL	Channel 48	FREQUENCY RANGE	1 ~ 40GHz
INPUT POWER (SYSTEM)	120Vac, 60 Hz	DETECTOR FUNCTION	Peak (PK) Average (AV)
ENVIRONMENTAL CONDITIONS	21deg. C, 68%RH	TESTED BY	Chad Lee

ANTENNA POLARITY & TEST DISTANCE: HORIZONTAL AT 3 M								
NO.	FREQ. (MHz)	EMISSION LEVEL (dBuV/m)	LIMIT (dBuV/m)	MARGIN (dB)	ANTENNA HEIGHT (m)	TABLE ANGLE (Degree)	RAW VALUE (dBuV)	CORRECTION FACTOR (dB/m)
1	*5240.00	103.8 PK			1.00 H	325	66.34	37.48
2	*5240.00	90.7 AV			1.00 H	325	53.18	37.48
3	5350.00	48.0 PK	74.0	-26.0	1.00 H	325	10.38	37.62
4	5350.00	38.5 AV	54.0	-15.5	1.00 H	325	0.91	37.62
5	#10480.00	57.9 PK	68.3	-10.4	1.00 H	168	10.40	47.49
ANTENNA POLARITY & TEST DISTANCE: VERTICAL AT 3 M								
NO.	FREQ. (MHz)	EMISSION LEVEL (dBuV/m)	LIMIT (dBuV/m)	MARGIN (dB)	ANTENNA HEIGHT (m)	TABLE ANGLE (Degree)	RAW VALUE (dBuV)	CORRECTION FACTOR (dB/m)
1	*5240.00	106.5 PK			1.00 V	150	69.01	37.48
2	*5240.00	93.7 AV			1.00 V	150	56.20	37.48
3	5350.00	51.0 PK	74.0	-23.0	1.00 V	150	13.38	37.62
4	5350.00	41.5 AV	54.0	-12.5	1.00 V	150	3.86	37.62
5	#10480.00	56.9 PK	68.3	-11.4	1.00 V	140	9.40	47.49

REMARKS:

1. Emission level (dBuV/m) = Raw Value (dBuV) + Correction Factor (dB/m).
2. Correction Factor (dB/m) = Antenna Factor (dB/m) + Cable Factor (dB).
3. The other emission levels were very low against the limit.
4. Margin value = Emission level – Limit value.
5. “ * “: Fundamental frequency.
6. “#”:The radiated frequency is out the restricted band.



A D T

EUT TEST CONDITION		MEASUREMENT DETAIL	
CHANNEL	Channel 52	FREQUENCY RANGE	1 ~ 40GHz
INPUT POWER (SYSTEM)	120Vac, 60 Hz	DETECTOR FUNCTION	Peak (PK) Average (AV)
ENVIRONMENTAL CONDITIONS	21deg. C, 68%RH	TESTED BY	Chad Lee

ANTENNA POLARITY & TEST DISTANCE: HORIZONTAL AT 3 M								
NO.	FREQ. (MHz)	EMISSION LEVEL (dBuV/m)	LIMIT (dBuV/m)	MARGIN (dB)	ANTENNA HEIGHT (m)	TABLE ANGLE (Degree)	RAW VALUE (dBuV)	CORRECTION FACTOR (dB/m)
1	5150.00	46.5 PK	74.0	-27.5	1.00 H	329	9.14	37.37
2	5150.00	37.0 AV	54.0	-17.0	1.00 H	329	-0.34	37.37
3	*5260.00	105.8 PK			1.00 H	329	68.29	37.51
4	*5260.00	92.8 AV			1.00 H	329	55.25	37.51
5	#10520.00	56.0 PK	68.3	-12.3	1.00 H	158	8.43	47.56

ANTENNA POLARITY & TEST DISTANCE: VERTICAL AT 3 M								
NO.	FREQ. (MHz)	EMISSION LEVEL (dBuV/m)	LIMIT (dBuV/m)	MARGIN (dB)	ANTENNA HEIGHT (m)	TABLE ANGLE (Degree)	RAW VALUE (dBuV)	CORRECTION FACTOR (dB/m)
1	5150.00	49.5 PK	74.0	-24.5	1.05 V	171	12.10	37.37
2	5150.00	39.7 AV	54.0	-14.3	1.05 V	171	2.36	37.37
3	*5260.00	109.8 PK			1.05 V	171	72.25	37.51
4	*5260.00	97.6 AV			1.05 V	171	60.13	37.51
5	#10520.00	57.0 PK	68.3	-11.3	1.00 V	289	9.43	47.56

REMARKS:

1. Emission level (dBuV/m) = Raw Value (dBuV) + Correction Factor (dB/m).
2. Correction Factor (dB/m) = Antenna Factor (dB/m) + Cable Factor (dB).
3. The other emission levels were very low against the limit.
4. Margin value = Emission level – Limit value.
5. “ * “: Fundamental frequency.
6. “#”:The radiated frequency is out the restricted band.



A D T

EUT TEST CONDITION		MEASUREMENT DETAIL	
CHANNEL	Channel 60	FREQUENCY RANGE	1 ~ 40GHz
INPUT POWER (SYSTEM)	120Vac, 60 Hz	DETECTOR FUNCTION	Peak (PK) Average (AV)
ENVIRONMENTAL CONDITIONS	21deg. C, 68%RH	TESTED BY	Chad Lee

ANTENNA POLARITY & TEST DISTANCE: HORIZONTAL AT 3 M								
NO.	FREQ. (MHz)	EMISSION LEVEL (dBuV/m)	LIMIT (dBuV/m)	MARGIN (dB)	ANTENNA HEIGHT (m)	TABLE ANGLE (Degree)	RAW VALUE (dBuV)	CORRECTION FACTOR (dB/m)
1	*5300.00	107.1 PK			1.36 H	310	69.56	37.56
2	*5300.00	93.8 AV			1.36 H	310	56.25	37.56
3	10600.00	57.0 PK	74.0	-17.0	1.00 H	123	9.26	47.69
4	10600.00	47.5 AV	54.0	-6.5	1.00 H	123	-0.21	47.69

ANTENNA POLARITY & TEST DISTANCE: VERTICAL AT 3 M								
NO.	FREQ. (MHz)	EMISSION LEVEL (dBuV/m)	LIMIT (dBuV/m)	MARGIN (dB)	ANTENNA HEIGHT (m)	TABLE ANGLE (Degree)	RAW VALUE (dBuV)	CORRECTION FACTOR (dB/m)
1	*5300.00	109.6 PK			1.20 V	282	72.01	37.56
2	*5300.00	96.8 AV			1.20 V	282	59.26	37.56
3	10600.00	56.0 PK	74.0	-18.0	1.00 V	2	8.26	47.69
4	10600.00	41.9 AV	54.0	-12.1	1.00 V	2	-5.81	47.69

REMARKS:

1. Emission level (dBuV/m) = Raw Value (dBuV) + Correction Factor (dB/m).
2. Correction Factor (dB/m) = Antenna Factor (dB/m) + Cable Factor (dB).
3. The other emission levels were very low against the limit.
4. Margin value = Emission level – Limit value.
5. “ * “: Fundamental frequency.



A D T

EUT TEST CONDITION		MEASUREMENT DETAIL	
CHANNEL	Channel 64	FREQUENCY RANGE	1 ~ 40GHz
INPUT POWER (SYSTEM)	120Vac, 60 Hz	DETECTOR FUNCTION	Peak (PK) Average (AV)
ENVIRONMENTAL CONDITIONS	21deg. C, 68%RH	TESTED BY	Chad Lee

ANTENNA POLARITY & TEST DISTANCE: HORIZONTAL AT 3 M								
NO.	FREQ. (MHz)	EMISSION LEVEL (dBuV/m)	LIMIT (dBuV/m)	MARGIN (dB)	ANTENNA HEIGHT (m)	TABLE ANGLE (Degree)	RAW VALUE (dBuV)	CORRECTION FACTOR (dB/m)
1	*5320.00	105.0 PK			1.11 H	191	67.44	37.58
2	*5320.00	92.7 AV			1.11 H	191	55.14	37.58
3	5350.00	65.3 PK	74.0	-8.8	1.11 H	191	27.63	37.62
4	5350.00	42.1 AV	54.0	-11.9	1.11 H	191	4.50	37.62
5	10640.00	58.0 PK	74.0	-16.0	1.00 H	15	10.24	47.75
6	10640.00	48.3 AV	54.0	-5.7	1.00 H	15	0.57	47.75
ANTENNA POLARITY & TEST DISTANCE: VERTICAL AT 3 M								
NO.	FREQ. (MHz)	EMISSION LEVEL (dBuV/m)	LIMIT (dBuV/m)	MARGIN (dB)	ANTENNA HEIGHT (m)	TABLE ANGLE (Degree)	RAW VALUE (dBuV)	CORRECTION FACTOR (dB/m)
1	*5320.00	109.9 PK			1.14 V	157	72.36	37.58
2	*5320.00	96.8 AV			1.14 V	157	59.22	37.58
3	5350.00	67.1 PK	74.0	-6.9	1.14 V	157	29.46	37.62
4	5350.00	44.1 AV	54.0	-9.9	1.14 V	157	6.45	37.62
5	10640.00	57.1 PK	74.0	-16.9	1.00 V	50	9.34	47.75
6	10640.00	42.3 AV	54.0	-11.7	1.00 V	50	-5.43	47.75

REMARKS:

1. Emission level (dBuV/m) = Raw Value (dBuV) + Correction Factor (dB/m).
2. Correction Factor (dB/m) = Antenna Factor (dB/m) + Cable Factor (dB).
3. The other emission levels were very low against the limit.
4. Margin value = Emission level – Limit value.
5. “ * “: Fundamental frequency.



A D T

EUT TEST CONDITION		MEASUREMENT DETAIL	
CHANNEL	Channel 100	FREQUENCY RANGE	1 ~ 40GHz
INPUT POWER (SYSTEM)	120Vac, 60 Hz	DETECTOR FUNCTION	Peak (PK) Average (AV)
ENVIRONMENTAL CONDITIONS	21deg. C, 68%RH	TESTED BY	Chad Lee

ANTENNA POLARITY & TEST DISTANCE: HORIZONTAL AT 3 M								
NO.	FREQ. (MHz)	EMISSION LEVEL (dBuV/m)	LIMIT (dBuV/m)	MARGIN (dB)	ANTENNA HEIGHT (m)	TABLE ANGLE (Degree)	RAW VALUE (dBuV)	CORRECTION FACTOR (dB/m)
1	5460.00	51.3 PK	74.0	-22.8	1.00 H	313	13.39	37.86
2	5460.00	37.2 AV	54.0	-16.8	1.00 H	313	-0.65	37.86
3	#5470.00	62.3 PK	68.3	-6.0	1.00 H	313	24.40	37.89
4	*5500.00	104.5 PK			1.00 H	313	66.49	37.98
5	*5500.00	91.2 AV			1.00 H	313	53.21	37.98
6	11000.00	58.9 PK	74.0	-15.1	1.00 H	147	10.55	48.39
7	11000.00	48.9 AV	54.0	-5.1	1.00 H	147	0.52	48.39
ANTENNA POLARITY & TEST DISTANCE: VERTICAL AT 3 M								
NO.	FREQ. (MHz)	EMISSION LEVEL (dBuV/m)	LIMIT (dBuV/m)	MARGIN (dB)	ANTENNA HEIGHT (m)	TABLE ANGLE (Degree)	RAW VALUE (dBuV)	CORRECTION FACTOR (dB/m)
1	5460.00	53.6 PK	74.0	-20.4	1.11 V	168	15.71	37.86
2	5460.00	40.6 AV	54.0	-13.4	1.11 V	168	2.76	37.86
3	#5470.00	64.4 PK	68.3	-3.9	1.11 V	168	26.52	37.89
4	*5500.00	108.0 PK			1.11 V	168	70.03	37.98
5	*5500.00	94.2 AV			1.11 V	168	56.25	37.98
6	11000.00	58.9 PK	74.0	-15.1	1.00 V	324	10.53	48.39
7	11000.00	43.9 AV	54.0	-10.1	1.00 V	324	-4.51	48.39

REMARKS:

1. Emission level (dBuV/m) = Raw Value (dBuV) + Correction Factor (dB/m).
2. Correction Factor (dB/m) = Antenna Factor (dB/m) + Cable Factor (dB).
3. The other emission levels were very low against the limit.
4. Margin value = Emission level – Limit value.
5. “ * “: Fundamental frequency.
6. "#":The radiated frequency is out the restricted band.



A D T

EUT TEST CONDITION		MEASUREMENT DETAIL	
CHANNEL	Channel 116	FREQUENCY RANGE	1 ~ 40GHz
INPUT POWER (SYSTEM)	120Vac, 60 Hz	DETECTOR FUNCTION	Peak (PK) Average (AV)
ENVIRONMENTAL CONDITIONS	21deg. C, 68%RH	TESTED BY	Chad Lee

ANTENNA POLARITY & TEST DISTANCE: HORIZONTAL AT 3 M								
NO.	FREQ. (MHz)	EMISSION LEVEL (dBuV/m)	LIMIT (dBuV/m)	MARGIN (dB)	ANTENNA HEIGHT (m)	TABLE ANGLE (Degree)	RAW VALUE (dBuV)	CORRECTION FACTOR (dB/m)
1	*5580.00	107.8 PK			1.00 H	201	69.72	38.11
2	*5580.00	94.2 AV			1.00 H	201	56.12	38.11
3	11600.00	59.3 PK	74.0	-14.7	1.00 H	19	11.12	48.21
4	11600.00	49.2 AV	54.0	-4.8	1.00 H	19	1.01	48.21

ANTENNA POLARITY & TEST DISTANCE: VERTICAL AT 3 M								
NO.	FREQ. (MHz)	EMISSION LEVEL (dBuV/m)	LIMIT (dBuV/m)	MARGIN (dB)	ANTENNA HEIGHT (m)	TABLE ANGLE (Degree)	RAW VALUE (dBuV)	CORRECTION FACTOR (dB/m)
1	*5580.00	110.8 PK			1.09 V	174	72.64	38.11
2	*5580.00	98.2 AV			1.09 V	174	60.12	38.11
3	11600.00	57.4 PK	74.0	-16.6	1.00 V	82	9.21	48.21
4	11600.00	43.6 AV	54.0	-10.4	1.00 V	82	-4.60	48.21

REMARKS:

1. Emission level (dBuV/m) = Raw Value (dBuV) + Correction Factor (dB/m).
2. Correction Factor (dB/m) = Antenna Factor (dB/m) + Cable Factor (dB).
3. The other emission levels were very low against the limit.
4. Margin value = Emission level – Limit value.
5. “ * “: Fundamental frequency.



A D T

EUT TEST CONDITION		MEASUREMENT DETAIL	
CHANNEL	Channel 140	FREQUENCY RANGE	1 ~ 40GHz
INPUT POWER (SYSTEM)	120Vac, 60 Hz	DETECTOR FUNCTION	Peak (PK) Average (AV)
ENVIRONMENTAL CONDITIONS	21deg. C, 68%RH	TESTED BY	Chad Lee

ANTENNA POLARITY & TEST DISTANCE: HORIZONTAL AT 3 M								
NO.	FREQ. (MHz)	EMISSION LEVEL (dBuV/m)	LIMIT (dBuV/m)	MARGIN (dB)	ANTENNA HEIGHT (m)	TABLE ANGLE (Degree)	RAW VALUE (dBuV)	CORRECTION FACTOR (dB/m)
1	*5700.00	106.1 PK			1.13 H	196	67.78	38.27
2	*5700.00	92.5 AV			1.13 H	196	54.25	38.27
3	#5725.00	65.3 PK	68.3	-8.7	1.13 H	196	27.03	38.31
4	11400.00	57.6 PK	74.0	-16.5	1.00 H	55	9.28	48.27
5	11400.00	48.1 AV	54.0	-5.9	1.00 H	55	-0.14	48.27
ANTENNA POLARITY & TEST DISTANCE: VERTICAL AT 3 M								
NO.	FREQ. (MHz)	EMISSION LEVEL (dBuV/m)	LIMIT (dBuV/m)	MARGIN (dB)	ANTENNA HEIGHT (m)	TABLE ANGLE (Degree)	RAW VALUE (dBuV)	CORRECTION FACTOR (dB/m)
1	*5700.00	108.5 PK			1.08 V	9	70.25	38.27
2	*5700.00	94.5 AV			1.08 V	9	56.27	38.27
3	#5725.00	62.3 PK	68.3	-11.7	1.08 V	9	24.01	38.31
4	11400.00	56.7 PK	74.0	-17.4	1.00 V	9	8.38	48.27
5	11400.00	42.5 AV	54.0	-11.5	1.00 V	9	-5.76	48.27

REMARKS:

1. Emission level (dBuV/m) = Raw Value (dBuV) + Correction Factor (dB/m).
2. Correction Factor (dB/m) = Antenna Factor (dB/m) + Cable Factor (dB).
3. The other emission levels were very low against the limit.
4. Margin value = Emission level – Limit value.
5. " * ": Fundamental frequency.
6. "#":The radiated frequency is out the restricted band.

802.11n (20MHz): 1TX

EUT TEST CONDITION		MEASUREMENT DETAIL	
CHANNEL	Channel 36	FREQUENCY RANGE	1 ~ 40GHz
INPUT POWER (SYSTEM)	120Vac, 60 Hz	DETECTOR FUNCTION	Peak (PK) Average (AV)
ENVIRONMENTAL CONDITIONS	21deg. C, 68%RH	TESTED BY	Chad Lee

ANTENNA POLARITY & TEST DISTANCE: HORIZONTAL AT 3 M								
NO.	FREQ. (MHz)	EMISSION LEVEL (dBuV/m)	LIMIT (dBuV/m)	MARGIN (dB)	ANTENNA HEIGHT (m)	TABLE ANGLE (Degree)	RAW VALUE (dBuV)	CORRECTION FACTOR (dB/m)
1	5150.00	60.2 PK	74.0	-13.8	1.03 H	301	22.85	37.37
2	5150.00	40.3 AV	54.0	-13.8	1.03 H	301	2.88	37.37
3	*5180.00	101.9 PK			1.03 H	301	64.51	37.41
4	*5180.00	87.6 AV			1.03 H	301	50.22	37.41
5	#10360.00	56.5 PK	68.3	-11.8	1.00 H	100	9.21	47.25

ANTENNA POLARITY & TEST DISTANCE: VERTICAL AT 3 M								
NO.	FREQ. (MHz)	EMISSION LEVEL (dBuV/m)	LIMIT (dBuV/m)	MARGIN (dB)	ANTENNA HEIGHT (m)	TABLE ANGLE (Degree)	RAW VALUE (dBuV)	CORRECTION FACTOR (dB/m)
1	5150.00	62.6 PK	74.0	-11.4	1.09 V	161	25.23	37.37
2	5150.00	42.3 AV	54.0	-11.7	1.09 V	161	4.92	37.37
3	*5180.00	107.9 PK			1.09 V	161	70.46	37.41
4	*5180.00	93.2 AV			1.09 V	161	55.81	37.41
5	#10360.00	56.4 PK	68.3	-11.9	1.00 V	109	9.16	47.25

REMARKS:

1. Emission level (dBuV/m) = Raw Value (dBuV) + Correction Factor (dB/m).
2. Correction Factor (dB/m) = Antenna Factor (dB/m) + Cable Factor (dB).
3. The other emission levels were very low against the limit.
4. Margin value = Emission level – Limit value.
5. “ * “: Fundamental frequency.
6. "#":The radiated frequency is out the restricted band.



A D T

EUT TEST CONDITION		MEASUREMENT DETAIL	
CHANNEL	Channel 40	FREQUENCY RANGE	1 ~ 40GHz
INPUT POWER (SYSTEM)	120Vac, 60 Hz	DETECTOR FUNCTION	Peak (PK) Average (AV)
ENVIRONMENTAL CONDITIONS	21deg. C, 68%RH	TESTED BY	Chad Lee

ANTENNA POLARITY & TEST DISTANCE: HORIZONTAL AT 3 M								
NO.	FREQ. (MHz)	EMISSION LEVEL (dBuV/m)	LIMIT (dBuV/m)	MARGIN (dB)	ANTENNA HEIGHT (m)	TABLE ANGLE (Degree)	RAW VALUE (dBuV)	CORRECTION FACTOR (dB/m)
1	*5200.00	102.4 PK			1.10 H	198	64.93	37.43
2	*5200.00	88.0 AV			1.10 H	198	50.52	37.43
3	#10400.00	56.3 PK	68.3	-12.0	1.00 H	114	9.02	47.31
ANTENNA POLARITY & TEST DISTANCE: VERTICAL AT 3 M								
NO.	FREQ. (MHz)	EMISSION LEVEL (dBuV/m)	LIMIT (dBuV/m)	MARGIN (dB)	ANTENNA HEIGHT (m)	TABLE ANGLE (Degree)	RAW VALUE (dBuV)	CORRECTION FACTOR (dB/m)
1	*5200.00	107.7 PK			1.17 V	178	70.25	37.43
2	*5200.00	93.1 AV			1.17 V	178	55.63	37.43
3	#10400.00	56.4 PK	68.3	-11.9	1.00 V	152	9.13	47.31

REMARKS:

1. Emission level (dBuV/m) = Raw Value (dBuV) + Correction Factor (dB/m).
2. Correction Factor (dB/m) = Antenna Factor (dB/m) + Cable Factor (dB).
3. The other emission levels were very low against the limit.
4. Margin value = Emission level – Limit value.
5. “ * “: Fundamental frequency.
6. “#”:The radiated frequency is out the restricted band.



A D T

EUT TEST CONDITION		MEASUREMENT DETAIL	
CHANNEL	Channel 48	FREQUENCY RANGE	1 ~ 40GHz
INPUT POWER (SYSTEM)	120Vac, 60 Hz	DETECTOR FUNCTION	Peak (PK) Average (AV)
ENVIRONMENTAL CONDITIONS	21deg. C, 68%RH	TESTED BY	Chad Lee

ANTENNA POLARITY & TEST DISTANCE: HORIZONTAL AT 3 M								
NO.	FREQ. (MHz)	EMISSION LEVEL (dBuV/m)	LIMIT (dBuV/m)	MARGIN (dB)	ANTENNA HEIGHT (m)	TABLE ANGLE (Degree)	RAW VALUE (dBuV)	CORRECTION FACTOR (dB/m)
1	*5240.00	104.6 PK			1.09 H	219	67.12	37.48
2	*5240.00	91.7 AV			1.09 H	219	54.25	37.48
3	5350.00	48.0 PK	74.0	-26.0	1.09 H	219	10.38	37.62
4	5350.00	37.9 AV	54.0	-16.1	1.09 H	219	0.27	37.62
5	#10480.00	56.9 PK	68.3	-11.4	1.03 H	321	9.40	47.49
ANTENNA POLARITY & TEST DISTANCE: VERTICAL AT 3 M								
NO.	FREQ. (MHz)	EMISSION LEVEL (dBuV/m)	LIMIT (dBuV/m)	MARGIN (dB)	ANTENNA HEIGHT (m)	TABLE ANGLE (Degree)	RAW VALUE (dBuV)	CORRECTION FACTOR (dB/m)
1	*5240.00	108.1 PK			1.10 V	166	70.62	37.48
2	*5240.00	93.7 AV			1.10 V	166	56.24	37.48
3	5350.00	51.0 PK	74.0	-23.0	1.10 V	166	13.38	37.62
4	5350.00	41.5 AV	54.0	-12.5	1.10 V	166	3.86	37.62
5	#10480.00	56.8 PK	68.3	-11.6	1.00 V	135	9.26	47.49

REMARKS:

1. Emission level (dBuV/m) = Raw Value (dBuV) + Correction Factor (dB/m).
2. Correction Factor (dB/m) = Antenna Factor (dB/m) + Cable Factor (dB).
3. The other emission levels were very low against the limit.
4. Margin value = Emission level – Limit value.
5. “ * “: Fundamental frequency.
6. “#”:The radiated frequency is out the restricted band.



A D T

EUT TEST CONDITION		MEASUREMENT DETAIL	
CHANNEL	Channel 52	FREQUENCY RANGE	1 ~ 40GHz
INPUT POWER (SYSTEM)	120Vac, 60 Hz	DETECTOR FUNCTION	Peak (PK) Average (AV)
ENVIRONMENTAL CONDITIONS	21deg. C, 68%RH	TESTED BY	Chad Lee

ANTENNA POLARITY & TEST DISTANCE: HORIZONTAL AT 3 M								
NO.	FREQ. (MHz)	EMISSION LEVEL (dBuV/m)	LIMIT (dBuV/m)	MARGIN (dB)	ANTENNA HEIGHT (m)	TABLE ANGLE (Degree)	RAW VALUE (dBuV)	CORRECTION FACTOR (dB/m)
1	5150.00	44.5 PK	74.0	-29.5	1.13 H	216	7.10	37.37
2	5150.00	34.7 AV	54.0	-19.3	1.13 H	216	-2.68	37.37
3	*5260.00	106.6 PK			1.13 H	216	69.09	37.51
4	*5260.00	93.7 AV			1.13 H	216	56.22	37.51
5	#10520.00	57.0 PK	68.3	-11.3	1.00 H	109	9.43	47.56

ANTENNA POLARITY & TEST DISTANCE: VERTICAL AT 3 M								
NO.	FREQ. (MHz)	EMISSION LEVEL (dBuV/m)	LIMIT (dBuV/m)	MARGIN (dB)	ANTENNA HEIGHT (m)	TABLE ANGLE (Degree)	RAW VALUE (dBuV)	CORRECTION FACTOR (dB/m)
1	5150.00	46.5 PK	74.0	-27.5	1.05 V	183	9.14	37.37
2	5150.00	36.4 AV	54.0	-17.6	1.05 V	183	-1.00	37.37
3	*5260.00	109.9 PK			1.05 V	183	72.40	37.51
4	*5260.00	97.7 AV			1.05 V	183	60.22	37.51
5	#10520.00	57.5 PK	68.3	-10.8	1.00 V	194	9.95	47.56

REMARKS:

1. Emission level (dBuV/m) = Raw Value (dBuV) + Correction Factor (dB/m).
2. Correction Factor (dB/m) = Antenna Factor (dB/m) + Cable Factor (dB).
3. The other emission levels were very low against the limit.
4. Margin value = Emission level – Limit value.
5. " * ": Fundamental frequency.
6. "#": The radiated frequency is out the restricted band.



A D T

EUT TEST CONDITION		MEASUREMENT DETAIL	
CHANNEL	Channel 60	FREQUENCY RANGE	1 ~ 40GHz
INPUT POWER (SYSTEM)	120Vac, 60 Hz	DETECTOR FUNCTION	Peak (PK) Average (AV)
ENVIRONMENTAL CONDITIONS	21deg. C, 68%RH	TESTED BY	Chad Lee

ANTENNA POLARITY & TEST DISTANCE: HORIZONTAL AT 3 M								
NO.	FREQ. (MHz)	EMISSION LEVEL (dBuV/m)	LIMIT (dBuV/m)	MARGIN (dB)	ANTENNA HEIGHT (m)	TABLE ANGLE (Degree)	RAW VALUE (dBuV)	CORRECTION FACTOR (dB/m)
1	*5300.00	106.2 PK			1.09 H	228	68.68	37.56
2	*5300.00	93.1 AV			1.09 H	228	55.58	37.56
3	10600.00	57.9 PK	74.0	-16.1	1.00 H	119	10.16	47.69
4	10600.00	48.4 AV	54.0	-5.6	1.00 H	119	0.74	47.69
ANTENNA POLARITY & TEST DISTANCE: VERTICAL AT 3 M								
NO.	FREQ. (MHz)	EMISSION LEVEL (dBuV/m)	LIMIT (dBuV/m)	MARGIN (dB)	ANTENNA HEIGHT (m)	TABLE ANGLE (Degree)	RAW VALUE (dBuV)	CORRECTION FACTOR (dB/m)
1	*5300.00	109.9 PK			1.06 V	193	72.32	37.56
2	*5300.00	98.4 AV			1.06 V	193	60.88	37.56
3	10600.00	56.0 PK	74.0	-18.0	1.00 V	281	8.26	47.69
4	10600.00	41.9 AV	54.0	-12.1	1.00 V	281	-5.83	47.69

REMARKS:

1. Emission level (dBuV/m) = Raw Value (dBuV) + Correction Factor (dB/m).
2. Correction Factor (dB/m) = Antenna Factor (dB/m) + Cable Factor (dB).
3. The other emission levels were very low against the limit.
4. Margin value = Emission level – Limit value.
5. “ * “: Fundamental frequency.



A D T

EUT TEST CONDITION		MEASUREMENT DETAIL	
CHANNEL	Channel 64	FREQUENCY RANGE	1 ~ 40GHz
INPUT POWER (SYSTEM)	120Vac, 60 Hz	DETECTOR FUNCTION	Peak (PK) Average (AV)
ENVIRONMENTAL CONDITIONS	21deg. C, 68%RH	TESTED BY	Chad Lee

ANTENNA POLARITY & TEST DISTANCE: HORIZONTAL AT 3 M								
NO.	FREQ. (MHz)	EMISSION LEVEL (dBuV/m)	LIMIT (dBuV/m)	MARGIN (dB)	ANTENNA HEIGHT (m)	TABLE ANGLE (Degree)	RAW VALUE (dBuV)	CORRECTION FACTOR (dB/m)
1	*5320.00	106.3 PK			1.06 H	212	68.74	37.58
2	*5320.00	93.5 AV			1.06 H	212	55.96	37.58
3	5350.00	62.1 PK	74.0	-11.9	1.06 H	212	24.50	37.62
4	5350.00	40.2 AV	54.0	-13.8	1.06 H	212	2.57	37.62
5	10640.00	57.1 PK	74.0	-16.9	1.00 H	283	9.34	47.75
6	10640.00	47.6 AV	54.0	-6.4	1.00 H	283	-0.18	47.75
ANTENNA POLARITY & TEST DISTANCE: VERTICAL AT 3 M								
NO.	FREQ. (MHz)	EMISSION LEVEL (dBuV/m)	LIMIT (dBuV/m)	MARGIN (dB)	ANTENNA HEIGHT (m)	TABLE ANGLE (Degree)	RAW VALUE (dBuV)	CORRECTION FACTOR (dB/m)
1	*5320.00	108.2 PK			1.06 V	165	70.59	37.58
2	*5320.00	94.8 AV			1.06 V	165	57.24	37.58
3	5350.00	64.2 PK	74.0	-9.8	1.06 V	165	26.61	37.62
4	5350.00	43.0 AV	54.0	-11.0	1.06 V	165	5.35	37.62
5	10640.00	56.1 PK	74.0	-17.9	1.00 V	103	8.34	47.75
6	10640.00	42.3 AV	54.0	-11.7	1.00 V	103	-5.43	47.75

REMARKS:

1. Emission level (dBuV/m) = Raw Value (dBuV) + Correction Factor (dB/m).
2. Correction Factor (dB/m) = Antenna Factor (dB/m) + Cable Factor (dB).
3. The other emission levels were very low against the limit.
4. Margin value = Emission level – Limit value.
5. “ * “: Fundamental frequency.

EUT TEST CONDITION		MEASUREMENT DETAIL	
CHANNEL	Channel 100	FREQUENCY RANGE	1 ~ 40GHz
INPUT POWER (SYSTEM)	120Vac, 60 Hz	DETECTOR FUNCTION	Peak (PK) Average (AV)
ENVIRONMENTAL CONDITIONS	21deg. C, 68%RH	TESTED BY	Chad Lee

ANTENNA POLARITY & TEST DISTANCE: HORIZONTAL AT 3 M								
NO.	FREQ. (MHz)	EMISSION LEVEL (dBuV/m)	LIMIT (dBuV/m)	MARGIN (dB)	ANTENNA HEIGHT (m)	TABLE ANGLE (Degree)	RAW VALUE (dBuV)	CORRECTION FACTOR (dB/m)
1	5460.00	56.7 PK	74.0	-17.3	1.11 H	203	18.85	37.86
2	5460.00	40.9 AV	54.0	-13.1	1.11 H	203	3.01	37.86
3	#5470.00	62.6 PK	68.3	-5.7	1.11 H	203	24.71	37.89
4	*5500.00	107.3 PK			1.11 H	203	69.28	37.98
5	*5500.00	94.2 AV			1.11 H	203	56.21	37.98
6	11000.00	58.9 PK	74.0	-15.1	1.03 H	114	10.54	48.39
7	11000.00	49.5 AV	54.0	-4.5	1.03 H	114	1.11	48.39
ANTENNA POLARITY & TEST DISTANCE: VERTICAL AT 3 M								
NO.	FREQ. (MHz)	EMISSION LEVEL (dBuV/m)	LIMIT (dBuV/m)	MARGIN (dB)	ANTENNA HEIGHT (m)	TABLE ANGLE (Degree)	RAW VALUE (dBuV)	CORRECTION FACTOR (dB/m)
1	5460.00	52.7 PK	74.0	-21.3	1.12 V	2	14.80	37.86
2	5460.00	36.0 AV	54.0	-18.1	1.12 V	2	-1.91	37.86
3	#5470.00	59.8 PK	68.3	-8.5	1.12 V	2	21.91	37.89
4	*5500.00	105.5 PK			1.12 V	2	67.53	37.98
5	*5500.00	92.1 AV			1.12 V	2	54.14	37.98
6	11000.00	58.0 PK	74.0	-16.0	1.00 V	41	9.63	48.39
7	11000.00	43.2 AV	54.0	-10.8	1.00 V	41	-5.15	48.39

REMARKS:

1. Emission level (dBuV/m) = Raw Value (dBuV) + Correction Factor (dB/m).
2. Correction Factor (dB/m) = Antenna Factor (dB/m) + Cable Factor (dB).
3. The other emission levels were very low against the limit.
4. Margin value = Emission level – Limit value.
5. “ * “: Fundamental frequency.
6. "#":The radiated frequency is out the restricted band.



A D T

EUT TEST CONDITION		MEASUREMENT DETAIL	
CHANNEL	Channel 116	FREQUENCY RANGE	1 ~ 40GHz
INPUT POWER (SYSTEM)	120Vac, 60 Hz	DETECTOR FUNCTION	Peak (PK) Average (AV)
ENVIRONMENTAL CONDITIONS	21deg. C, 68%RH	TESTED BY	Chad Lee

ANTENNA POLARITY & TEST DISTANCE: HORIZONTAL AT 3 M								
NO.	FREQ. (MHz)	EMISSION LEVEL (dBuV/m)	LIMIT (dBuV/m)	MARGIN (dB)	ANTENNA HEIGHT (m)	TABLE ANGLE (Degree)	RAW VALUE (dBuV)	CORRECTION FACTOR (dB/m)
1	*5580.00	107.1 PK			1.13 H	218	69.03	38.11
2	*5580.00	94.0 AV			1.13 H	218	55.92	38.11
3	11600.00	59.0 PK	74.0	-15.0	1.00 H	108	10.78	48.21
4	11600.00	49.6 AV	54.0	-4.4	1.00 H	108	1.42	48.21
ANTENNA POLARITY & TEST DISTANCE: VERTICAL AT 3 M								
NO.	FREQ. (MHz)	EMISSION LEVEL (dBuV/m)	LIMIT (dBuV/m)	MARGIN (dB)	ANTENNA HEIGHT (m)	TABLE ANGLE (Degree)	RAW VALUE (dBuV)	CORRECTION FACTOR (dB/m)
1	*5580.00	105.5 PK			1.19 V	28	67.35	38.11
2	*5580.00	92.1 AV			1.19 V	28	53.99	38.11
3	11600.00	58.1 PK	74.0	-15.9	1.00 V	94	9.90	48.21
4	11600.00	43.1 AV	54.0	-10.9	1.00 V	94	-5.12	48.21

REMARKS:

1. Emission level (dBuV/m) = Raw Value (dBuV) + Correction Factor (dB/m).
2. Correction Factor (dB/m) = Antenna Factor (dB/m) + Cable Factor (dB).
3. The other emission levels were very low against the limit.
4. Margin value = Emission level – Limit value.
5. “ * “: Fundamental frequency.



EUT TEST CONDITION		MEASUREMENT DETAIL	
CHANNEL	Channel 140	FREQUENCY RANGE	1 ~ 40GHz
INPUT POWER (SYSTEM)	120Vac, 60 Hz	DETECTOR FUNCTION	Peak (PK) Average (AV)
ENVIRONMENTAL CONDITIONS	21deg. C, 68%RH	TESTED BY	Chad Lee

ANTENNA POLARITY & TEST DISTANCE: HORIZONTAL AT 3 M								
NO.	FREQ. (MHz)	EMISSION LEVEL (dBuV/m)	LIMIT (dBuV/m)	MARGIN (dB)	ANTENNA HEIGHT (m)	TABLE ANGLE (Degree)	RAW VALUE (dBuV)	CORRECTION FACTOR (dB/m)
1	*5700.00	108.8 PK			1.24 H	216	70.49	38.27
2	*5700.00	95.3 AV			1.24 H	216	57.04	38.27
3	#5725.00	64.3 PK	68.3	-9.7	1.24 H	216	26.03	38.31
4	11400.00	59.7 PK	74.0	-14.4	1.00 H	205	11.38	48.27
5	11400.00	49.8 AV	54.0	-4.2	1.00 H	205	1.56	48.27
ANTENNA POLARITY & TEST DISTANCE: VERTICAL AT 3 M								
NO.	FREQ. (MHz)	EMISSION LEVEL (dBuV/m)	LIMIT (dBuV/m)	MARGIN (dB)	ANTENNA HEIGHT (m)	TABLE ANGLE (Degree)	RAW VALUE (dBuV)	CORRECTION FACTOR (dB/m)
1	*5700.00	107.2 PK			1.17 V	11	68.97	38.27
2	*5700.00	93.5 AV			1.17 V	11	55.24	38.27
3	#5725.00	64.0 PK	68.3	-10.1	1.17 V	11	25.64	38.31
4	11400.00	55.7 PK	74.0	-18.3	1.00 V	201	7.41	48.27
5	11400.00	43.1 AV	54.0	-10.9	1.00 V	201	-5.14	48.27

REMARKS:

1. Emission level (dBuV/m) = Raw Value (dBuV) + Correction Factor (dB/m).
2. Correction Factor (dB/m) = Antenna Factor (dB/m) + Cable Factor (dB).
3. The other emission levels were very low against the limit.
4. Margin value = Emission level – Limit value.
5. “ * “: Fundamental frequency.
6. "#":The radiated frequency is out the restricted band.

802.11n (40MHz): 1TX

EUT TEST CONDITION		MEASUREMENT DETAIL	
CHANNEL	Channel 38	FREQUENCY RANGE	1 ~ 40GHz
INPUT POWER (SYSTEM)	120Vac, 60 Hz	DETECTOR FUNCTION	Peak (PK) Average (AV)
ENVIRONMENTAL CONDITIONS	24deg. C, 86%RH	TESTED BY	Chad Lee

ANTENNA POLARITY & TEST DISTANCE: HORIZONTAL AT 3 M								
NO.	FREQ. (MHz)	EMISSION LEVEL (dBuV/m)	LIMIT (dBuV/m)	MARGIN (dB)	ANTENNA HEIGHT (m)	TABLE ANGLE (Degree)	RAW VALUE (dBuV)	CORRECTION FACTOR (dB/m)
1	5150.00	69.2 PK	74.0	-4.9	1.40 H	313	31.78	37.37
2	5150.00	49.7 AV	54.0	-4.3	1.40 H	313	12.30	37.37
3	*5190.00	98.8 PK			1.40 H	313	61.40	37.42
4	*5190.00	85.6 AV			1.40 H	313	48.14	37.42
5	#10380.00	56.5 PK	68.3	-11.9	1.00 H	32	9.17	47.28

ANTENNA POLARITY & TEST DISTANCE: VERTICAL AT 3 M								
NO.	FREQ. (MHz)	EMISSION LEVEL (dBuV/m)	LIMIT (dBuV/m)	MARGIN (dB)	ANTENNA HEIGHT (m)	TABLE ANGLE (Degree)	RAW VALUE (dBuV)	CORRECTION FACTOR (dB/m)
1	5150.00	72.9 PK	74.0	-1.1	1.00 V	167	35.49	37.37
2	5150.00	52.6 AV	54.0	-1.4	1.00 V	167	15.25	37.37
3	*5190.00	102.6 PK			1.00 V	167	65.14	37.42
4	*5190.00	89.1 AV			1.00 V	167	51.64	37.42
5	#10380.00	56.5 PK	68.3	-11.9	1.00 V	148	9.17	47.28

REMARKS:

1. Emission level (dBuV/m) = Raw Value (dBuV) + Correction Factor (dB/m).
2. Correction Factor (dB/m) = Antenna Factor (dB/m) + Cable Factor (dB).
3. The other emission levels were very low against the limit.
4. Margin value = Emission level – Limit value.
5. “ * “: Fundamental frequency.
6. "#":The radiated frequency is out the restricted band.



A D T

EUT TEST CONDITION		MEASUREMENT DETAIL	
CHANNEL	Channel 46	FREQUENCY RANGE	1 ~ 40GHz
INPUT POWER (SYSTEM)	120Vac, 60 Hz	DETECTOR FUNCTION	Peak (PK) Average (AV)
ENVIRONMENTAL CONDITIONS	24deg. C, 86%RH	TESTED BY	Chad Lee

ANTENNA POLARITY & TEST DISTANCE: HORIZONTAL AT 3 M								
NO.	FREQ. (MHz)	EMISSION LEVEL (dBuV/m)	LIMIT (dBuV/m)	MARGIN (dB)	ANTENNA HEIGHT (m)	TABLE ANGLE (Degree)	RAW VALUE (dBuV)	CORRECTION FACTOR (dB/m)
1	*5230.00	101.1 PK			1.17 H	197	63.60	37.47
2	*5230.00	87.7 AV			1.17 H	197	50.24	37.47
3	5350.00	45.9 PK	74.0	-28.1	1.17 H	197	8.25	37.62
4	5350.00	35.8 AV	54.0	-18.2	1.17 H	197	-1.86	37.62
5	#10460.00	56.8 PK	68.3	-11.5	1.00 H	141	9.34	47.44
ANTENNA POLARITY & TEST DISTANCE: VERTICAL AT 3 M								
NO.	FREQ. (MHz)	EMISSION LEVEL (dBuV/m)	LIMIT (dBuV/m)	MARGIN (dB)	ANTENNA HEIGHT (m)	TABLE ANGLE (Degree)	RAW VALUE (dBuV)	CORRECTION FACTOR (dB/m)
1	*5230.00	102.8 PK			1.02 V	274	65.37	37.47
2	*5230.00	90.1 AV			1.02 V	274	52.63	37.47
3	5350.00	44.9 PK	74.0	-29.1	1.02 V	274	7.32	37.62
4	5350.00	34.9 AV	54.0	-19.1	1.02 V	274	-2.74	37.62
5	#10460.00	56.8 PK	68.3	-11.5	1.00 V	195	9.34	47.44

REMARKS:

1. Emission level (dBuV/m) = Raw Value (dBuV) + Correction Factor (dB/m).
2. Correction Factor (dB/m) = Antenna Factor (dB/m) + Cable Factor (dB).
3. The other emission levels were very low against the limit.
4. Margin value = Emission level – Limit value.
5. “ * “: Fundamental frequency.
6. “#”:The radiated frequency is out the restricted band.



A D T

EUT TEST CONDITION		MEASUREMENT DETAIL	
CHANNEL	Channel 54	FREQUENCY RANGE	1 ~ 40GHz
INPUT POWER (SYSTEM)	120Vac, 60 Hz	DETECTOR FUNCTION	Peak (PK) Average (AV)
ENVIRONMENTAL CONDITIONS	24deg. C, 86%RH	TESTED BY	Chad Lee

ANTENNA POLARITY & TEST DISTANCE: HORIZONTAL AT 3 M								
NO.	FREQ. (MHz)	EMISSION LEVEL (dBuV/m)	LIMIT (dBuV/m)	MARGIN (dB)	ANTENNA HEIGHT (m)	TABLE ANGLE (Degree)	RAW VALUE (dBuV)	CORRECTION FACTOR (dB/m)
1	5150.00	47.5 PK	74.0	-26.5	1.00 H	330	10.14	37.37
2	5150.00	37.4 AV	54.0	-16.6	1.00 H	330	0.02	37.37
3	*5260.00	99.9 PK			1.00 H	330	62.42	37.51
4	*5260.00	87.6 AV			1.00 H	330	50.11	37.51
5	#10540.00	57.0 PK	68.3	-11.3	1.00 H	142	9.39	47.59

ANTENNA POLARITY & TEST DISTANCE: VERTICAL AT 3 M								
NO.	FREQ. (MHz)	EMISSION LEVEL (dBuV/m)	LIMIT (dBuV/m)	MARGIN (dB)	ANTENNA HEIGHT (m)	TABLE ANGLE (Degree)	RAW VALUE (dBuV)	CORRECTION FACTOR (dB/m)
1	5150.00	50.5 PK	74.0	-23.5	1.29 V	258	13.14	37.37
2	5150.00	40.4 AV	54.0	-13.6	1.29 V	258	3.03	37.37
3	*5270.00	102.3 PK			1.29 V	258	64.81	37.52
4	*5270.00	88.7 AV			1.29 V	258	51.22	37.52
5	#10540.00	56.0 PK	68.3	-12.3	1.00 V	9	8.39	47.59

REMARKS:

1. Emission level (dBuV/m) = Raw Value (dBuV) + Correction Factor (dB/m).
2. Correction Factor (dB/m) = Antenna Factor (dB/m) + Cable Factor (dB).
3. The other emission levels were very low against the limit.
4. Margin value = Emission level – Limit value.
5. “ * “: Fundamental frequency.
6. “#”:The radiated frequency is out the restricted band.



A D T

EUT TEST CONDITION		MEASUREMENT DETAIL	
CHANNEL	Channel 62	FREQUENCY RANGE	1 ~ 40GHz
INPUT POWER (SYSTEM)	120Vac, 60 Hz	DETECTOR FUNCTION	Peak (PK) Average (AV)
ENVIRONMENTAL CONDITIONS	24deg. C, 86%RH	TESTED BY	Chad Lee

ANTENNA POLARITY & TEST DISTANCE: HORIZONTAL AT 3 M								
NO.	FREQ. (MHz)	EMISSION LEVEL (dBuV/m)	LIMIT (dBuV/m)	MARGIN (dB)	ANTENNA HEIGHT (m)	TABLE ANGLE (Degree)	RAW VALUE (dBuV)	CORRECTION FACTOR (dB/m)
1	*5310.00	100.3 PK			1.00 H	202	62.74	37.58
2	*5310.00	85.7 AV			1.00 H	202	48.13	37.58
3	5350.00	69.4 PK	74.0	-4.6	1.00 H	202	31.79	37.63
4	5350.00	50.2 AV	54.0	-3.8	1.00 H	202	12.58	37.63
5	10620.00	58.0 PK	74.0	-16.0	1.00 H	201	10.26	47.72
6	10620.00	48.3 AV	54.0	-5.8	1.00 H	201	0.53	47.72
ANTENNA POLARITY & TEST DISTANCE: VERTICAL AT 3 M								
NO.	FREQ. (MHz)	EMISSION LEVEL (dBuV/m)	LIMIT (dBuV/m)	MARGIN (dB)	ANTENNA HEIGHT (m)	TABLE ANGLE (Degree)	RAW VALUE (dBuV)	CORRECTION FACTOR (dB/m)
1	*5310.00	102.4 PK			1.00 V	259	64.84	37.57
2	*5310.00	87.8 AV			1.00 V	259	50.24	37.57
3	5350.00	72.2 PK	74.0	-1.8	1.00 V	259	34.55	37.62
4	5350.00	52.6 AV	54.0	-1.4	1.00 V	259	14.99	37.62
5	10620.00	57.0 PK	74.0	-17.0	1.00 V	114	9.26	47.72
6	10620.00	42.2 AV	54.0	-11.8	1.00 V	114	-5.51	47.72

REMARKS:

1. Emission level (dBuV/m) = Raw Value (dBuV) + Correction Factor (dB/m).
2. Correction Factor (dB/m) = Antenna Factor (dB/m) + Cable Factor (dB).
3. The other emission levels were very low against the limit.
4. Margin value = Emission level – Limit value.
5. “ * “: Fundamental frequency.

EUT TEST CONDITION		MEASUREMENT DETAIL	
CHANNEL	Channel 102	FREQUENCY RANGE	1 ~ 40GHz
INPUT POWER (SYSTEM)	120Vac, 60 Hz	DETECTOR FUNCTION	Peak (PK) Average (AV)
ENVIRONMENTAL CONDITIONS	24deg. C, 86%RH	TESTED BY	Chad Lee

ANTENNA POLARITY & TEST DISTANCE: HORIZONTAL AT 3 M								
NO.	FREQ. (MHz)	EMISSION LEVEL (dBuV/m)	LIMIT (dBuV/m)	MARGIN (dB)	ANTENNA HEIGHT (m)	TABLE ANGLE (Degree)	RAW VALUE (dBuV)	CORRECTION FACTOR (dB/m)
1	5460.00	52.7 PK	74.0	-21.3	1.20 H	24	14.88	37.86
2	5460.00	39.2 AV	54.0	-14.9	1.20 H	24	1.29	37.86
3	#5470.00	63.4 PK	68.3	-4.9	1.20 H	24	25.53	37.89
4	*5510.00	100.4 PK			1.20 H	24	62.35	38.00
5	*5510.00	87.5 AV			1.20 H	24	49.48	38.00
6	11020.00	58.7 PK	74.0	-15.3	1.00 H	63	10.29	48.38
7	11020.00	44.0 AV	54.0	-10.1	1.00 H	63	-4.43	48.38
ANTENNA POLARITY & TEST DISTANCE: VERTICAL AT 3 M								
NO.	FREQ. (MHz)	EMISSION LEVEL (dBuV/m)	LIMIT (dBuV/m)	MARGIN (dB)	ANTENNA HEIGHT (m)	TABLE ANGLE (Degree)	RAW VALUE (dBuV)	CORRECTION FACTOR (dB/m)
1	5460.00	54.3 PK	74.0	-19.7	1.07 V	168	16.42	37.86
2	5460.00	41.6 AV	54.0	-12.4	1.07 V	168	3.73	37.86
3	#5470.00	66.4 PK	68.3	-1.9	1.07 V	168	28.53	37.89
4	*5510.00	102.9 PK			1.07 V	168	64.92	38.00
5	*5510.00	90.5 AV			1.07 V	168	52.47	38.00
6	11020.00	57.2 PK	74.0	-16.8	1.00 V	21	8.86	48.38
7	11020.00	42.2 AV	54.0	-11.8	1.00 V	21	-6.19	48.38

REMARKS:

1. Emission level (dBuV/m) = Raw Value (dBuV) + Correction Factor (dB/m).
2. Correction Factor (dB/m) = Antenna Factor (dB/m) + Cable Factor (dB).
3. The other emission levels were very low against the limit.
4. Margin value = Emission level – Limit value.
5. “ * “: Fundamental frequency.
6. "#":The radiated frequency is out the restricted band.



A D T

EUT TEST CONDITION		MEASUREMENT DETAIL	
CHANNEL	Channel 110	FREQUENCY RANGE	1 ~ 40GHz
INPUT POWER (SYSTEM)	120Vac, 60 Hz	DETECTOR FUNCTION	Peak (PK) Average (AV)
ENVIRONMENTAL CONDITIONS	24deg. C, 86%RH	TESTED BY	Chad Lee

ANTENNA POLARITY & TEST DISTANCE: HORIZONTAL AT 3 M								
NO.	FREQ. (MHz)	EMISSION LEVEL (dBuV/m)	LIMIT (dBuV/m)	MARGIN (dB)	ANTENNA HEIGHT (m)	TABLE ANGLE (Degree)	RAW VALUE (dBuV)	CORRECTION FACTOR (dB/m)
1	*5550.00	102.0 PK			1.13 H	205	63.92	38.06
2	*5550.00	88.5 AV			1.13 H	205	50.42	38.06
3	11100.00	58.1 PK	74.0	-15.9	1.00 H	148	9.76	48.31
4	11100.00	48.6 AV	54.0	-5.4	1.00 H	148	0.29	48.31

ANTENNA POLARITY & TEST DISTANCE: VERTICAL AT 3 M								
NO.	FREQ. (MHz)	EMISSION LEVEL (dBuV/m)	LIMIT (dBuV/m)	MARGIN (dB)	ANTENNA HEIGHT (m)	TABLE ANGLE (Degree)	RAW VALUE (dBuV)	CORRECTION FACTOR (dB/m)
1	*5550.00	102.4 PK			1.00 V	169	64.30	38.06
2	*5550.00	90.2 AV			1.00 V	169	52.16	38.06
3	11100.00	58.0 PK	74.0	-16.0	1.00 V	7	9.73	48.31
4	11100.00	42.7 AV	54.0	-11.3	1.00 V	7	-5.65	48.31

REMARKS:

1. Emission level (dBuV/m) = Raw Value (dBuV) + Correction Factor (dB/m).
2. Correction Factor (dB/m) = Antenna Factor (dB/m) + Cable Factor (dB).
3. The other emission levels were very low against the limit.
4. Margin value = Emission level – Limit value.
5. “ * “: Fundamental frequency.



A D T

EUT TEST CONDITION		MEASUREMENT DETAIL	
CHANNEL	Channel 134	FREQUENCY RANGE	1 ~ 40GHz
INPUT POWER (SYSTEM)	120Vac, 60 Hz	DETECTOR FUNCTION	Peak (PK) Average (AV)
ENVIRONMENTAL CONDITIONS	24deg. C, 86%RH	TESTED BY	Chad Lee

ANTENNA POLARITY & TEST DISTANCE: HORIZONTAL AT 3 M								
NO.	FREQ. (MHz)	EMISSION LEVEL (dBuV/m)	LIMIT (dBuV/m)	MARGIN (dB)	ANTENNA HEIGHT (m)	TABLE ANGLE (Degree)	RAW VALUE (dBuV)	CORRECTION FACTOR (dB/m)
1	*5670.00	98.8 PK			1.00 H	348	58.79	39.96
2	*5670.00	85.3 AV			1.00 H	348	45.36	39.96
3	#5725.00	55.0 PK	68.3	-19.0	1.00 H	348	15.05	39.98
4	11340.00	56.7 PK	74.0	-17.3	1.00 H	110	9.68	47.04
5	11340.00	47.0 AV	54.0	-7.1	1.00 H	110	-0.09	47.04
ANTENNA POLARITY & TEST DISTANCE: VERTICAL AT 3 M								
NO.	FREQ. (MHz)	EMISSION LEVEL (dBuV/m)	LIMIT (dBuV/m)	MARGIN (dB)	ANTENNA HEIGHT (m)	TABLE ANGLE (Degree)	RAW VALUE (dBuV)	CORRECTION FACTOR (dB/m)
1	*5670.00	101.9 PK			1.25 V	22	61.90	39.96
2	*5670.00	88.2 AV			1.25 V	22	48.22	39.96
3	#5725.00	57.1 PK	68.3	-16.9	1.25 V	22	17.11	39.98
4	11340.00	57.2 PK	74.0	-16.8	1.00 V	151	10.20	47.04
5	11340.00	42.0 AV	54.0	-12.1	1.00 V	151	-5.09	47.04

REMARKS:

1. Emission level (dBuV/m) = Raw Value (dBuV) + Correction Factor (dB/m).
2. Correction Factor (dB/m) = Antenna Factor (dB/m) + Cable Factor (dB).
3. The other emission levels were very low against the limit.
4. Margin value = Emission level – Limit value.
5. “ * “: Fundamental frequency.
6. “#”:The radiated frequency is out the restricted band.



A D T

802.11n (20MHz): 2TX

EUT TEST CONDITION		MEASUREMENT DETAIL	
CHANNEL	Channel 36	FREQUENCY RANGE	1 ~ 40GHz
INPUT POWER (SYSTEM)	120Vac, 60 Hz	DETECTOR FUNCTION	Peak (PK) Average (AV)
ENVIRONMENTAL CONDITIONS	24deg. C, 86%RH	TESTED BY	Chad Lee

ANTENNA POLARITY & TEST DISTANCE: HORIZONTAL AT 3 M								
NO.	FREQ. (MHz)	EMISSION LEVEL (dBuV/m)	LIMIT (dBuV/m)	MARGIN (dB)	ANTENNA HEIGHT (m)	TABLE ANGLE (Degree)	RAW VALUE (dBuV)	CORRECTION FACTOR (dB/m)
1	5150.00	55.3 PK	74.0	-18.7	1.05 H	302	17.95	37.37
2	5150.00	40.0 AV	54.0	-14.0	1.05 H	302	2.67	37.37
3	*5180.00	99.8 PK			1.05 H	302	62.39	37.41
4	*5180.00	85.7 AV			1.05 H	302	48.25	37.41
5	#10360.00	56.5 PK	68.3	-11.8	1.00 H	181	9.21	47.25

ANTENNA POLARITY & TEST DISTANCE: VERTICAL AT 3 M								
NO.	FREQ. (MHz)	EMISSION LEVEL (dBuV/m)	LIMIT (dBuV/m)	MARGIN (dB)	ANTENNA HEIGHT (m)	TABLE ANGLE (Degree)	RAW VALUE (dBuV)	CORRECTION FACTOR (dB/m)
1	5150.00	57.1 PK	74.0	-16.9	1.08 V	172	19.76	37.37
2	5150.00	41.3 AV	54.0	-12.7	1.08 V	172	3.90	37.37
3	*5180.00	105.5 PK			1.08 V	172	68.04	37.41
4	*5180.00	91.8 AV			1.08 V	172	54.36	37.41
5	#10360.00	56.5 PK	68.3	-11.8	1.00 V	139	9.21	47.25

REMARKS:

1. Emission level (dBuV/m) = Raw Value (dBuV) + Correction Factor (dB/m).
2. Correction Factor (dB/m) = Antenna Factor (dB/m) + Cable Factor (dB).
3. The other emission levels were very low against the limit.
4. Margin value = Emission level – Limit value.
5. “ * “: Fundamental frequency.
6. "#":The radiated frequency is out the restricted band.



A D T

EUT TEST CONDITION		MEASUREMENT DETAIL	
CHANNEL	Channel 40	FREQUENCY RANGE	1 ~ 40GHz
INPUT POWER (SYSTEM)	120Vac, 60 Hz	DETECTOR FUNCTION	Peak (PK) Average (AV)
ENVIRONMENTAL CONDITIONS	24deg. C, 86%RH	TESTED BY	Chad Lee

ANTENNA POLARITY & TEST DISTANCE: HORIZONTAL AT 3 M								
NO.	FREQ. (MHz)	EMISSION LEVEL (dBuV/m)	LIMIT (dBuV/m)	MARGIN (dB)	ANTENNA HEIGHT (m)	TABLE ANGLE (Degree)	RAW VALUE (dBuV)	CORRECTION FACTOR (dB/m)
1	*5200.00	100.0 PK			1.09 H	311	62.53	37.43
2	*5200.00	85.7 AV			1.09 H	311	48.31	37.43
3	#10400.00	57.2 PK	68.3	-11.1	1.00 H	228	9.91	47.31
ANTENNA POLARITY & TEST DISTANCE: VERTICAL AT 3 M								
NO.	FREQ. (MHz)	EMISSION LEVEL (dBuV/m)	LIMIT (dBuV/m)	MARGIN (dB)	ANTENNA HEIGHT (m)	TABLE ANGLE (Degree)	RAW VALUE (dBuV)	CORRECTION FACTOR (dB/m)
1	*5200.00	105.6 PK			1.10 V	180	68.20	37.43
2	*5200.00	91.8 AV			1.10 V	180	54.39	37.43
3	#10400.00	56.7 PK	68.3	-11.6	1.00 V	148	9.41	47.31

REMARKS:

1. Emission level (dBuV/m) = Raw Value (dBuV) + Correction Factor (dB/m).
2. Correction Factor (dB/m) = Antenna Factor (dB/m) + Cable Factor (dB).
3. The other emission levels were very low against the limit.
4. Margin value = Emission level – Limit value.
5. " * ": Fundamental frequency.
6. "#":The radiated frequency is out the restricted band.



EUT TEST CONDITION		MEASUREMENT DETAIL	
CHANNEL	Channel 48	FREQUENCY RANGE	1 ~ 40GHz
INPUT POWER (SYSTEM)	120Vac, 60 Hz	DETECTOR FUNCTION	Peak (PK) Average (AV)
ENVIRONMENTAL CONDITIONS	24deg. C, 86%RH	TESTED BY	Chad Lee

ANTENNA POLARITY & TEST DISTANCE: HORIZONTAL AT 3 M								
NO.	FREQ. (MHz)	EMISSION LEVEL (dBuV/m)	LIMIT (dBuV/m)	MARGIN (dB)	ANTENNA HEIGHT (m)	TABLE ANGLE (Degree)	RAW VALUE (dBuV)	CORRECTION FACTOR (dB/m)
1	*5240.00	100.4 PK			1.06 H	311	62.88	37.48
2	*5240.00	87.1 AV			1.06 H	311	49.64	37.48
3	5350.00	45.9 PK	74.0	-28.2	1.06 H	311	8.23	37.62
4	5350.00	35.7 AV	54.0	-18.3	1.06 H	311	-1.92	37.62
5	#10400.00	57.5 PK	68.3	-10.9	1.00 H	218	10.14	47.31
ANTENNA POLARITY & TEST DISTANCE: VERTICAL AT 3 M								
NO.	FREQ. (MHz)	EMISSION LEVEL (dBuV/m)	LIMIT (dBuV/m)	MARGIN (dB)	ANTENNA HEIGHT (m)	TABLE ANGLE (Degree)	RAW VALUE (dBuV)	CORRECTION FACTOR (dB/m)
1	*5240.00	105.8 PK			1.17 V	167	68.33	37.48
2	*5240.00	92.7 AV			1.17 V	167	55.24	37.48
3	5350.00	48.0 PK	74.0	-26.0	1.17 V	167	10.38	37.62
4	5350.00	37.9 AV	54.0	-16.2	1.17 V	167	0.23	37.62
5	#10480.00	56.8 PK	68.3	-11.6	1.00 V	7	9.26	47.49

REMARKS:

1. Emission level (dBuV/m) = Raw Value (dBuV) + Correction Factor (dB/m).
2. Correction Factor (dB/m) = Antenna Factor (dB/m) + Cable Factor (dB).
3. The other emission levels were very low against the limit.
4. Margin value = Emission level – Limit value.
5. “ * “: Fundamental frequency.
6. "#":The radiated frequency is out the restricted band.



A D T

EUT TEST CONDITION		MEASUREMENT DETAIL	
CHANNEL	Channel 52	FREQUENCY RANGE	1 ~ 40GHz
INPUT POWER (SYSTEM)	120Vac, 60 Hz	DETECTOR FUNCTION	Peak (PK) Average (AV)
ENVIRONMENTAL CONDITIONS	24deg. C, 86%RH	TESTED BY	Chad Lee

ANTENNA POLARITY & TEST DISTANCE: HORIZONTAL AT 3 M								
NO.	FREQ. (MHz)	EMISSION LEVEL (dBuV/m)	LIMIT (dBuV/m)	MARGIN (dB)	ANTENNA HEIGHT (m)	TABLE ANGLE (Degree)	RAW VALUE (dBuV)	CORRECTION FACTOR (dB/m)
1	5150.00	44.5 PK	74.0	-29.5	1.31 H	147	7.10	37.37
2	5150.00	34.4 AV	54.0	-19.6	1.31 H	147	-2.97	37.37
3	*5260.00	103.8 PK			1.31 H	147	66.30	37.51
4	*5260.00	90.7 AV			1.31 H	147	53.21	37.51
5	#10520.00	57.5 PK	68.3	-10.8	1.00 H	148	9.93	47.56

ANTENNA POLARITY & TEST DISTANCE: VERTICAL AT 3 M								
NO.	FREQ. (MHz)	EMISSION LEVEL (dBuV/m)	LIMIT (dBuV/m)	MARGIN (dB)	ANTENNA HEIGHT (m)	TABLE ANGLE (Degree)	RAW VALUE (dBuV)	CORRECTION FACTOR (dB/m)
1	5150.00	47.2 PK	74.0	-26.8	1.16 V	171	9.87	37.37
2	5150.00	37.3 AV	54.0	-16.7	1.16 V	171	-0.10	37.37
3	*5260.00	107.3 PK			1.16 V	171	69.80	37.51
4	*5260.00	93.7 AV			1.16 V	171	56.22	37.51
5	#10520.00	58.0 PK	68.3	-10.4	1.00 V	114	10.39	47.56

REMARKS:

1. Emission level (dBuV/m) = Raw Value (dBuV) + Correction Factor (dB/m).
2. Correction Factor (dB/m) = Antenna Factor (dB/m) + Cable Factor (dB).
3. The other emission levels were very low against the limit.
4. Margin value = Emission level – Limit value.
5. “ * “: Fundamental frequency.
6. “#”:The radiated frequency is out the restricted band.



A D T

EUT TEST CONDITION		MEASUREMENT DETAIL	
CHANNEL	Channel 60	FREQUENCY RANGE	1 ~ 40GHz
INPUT POWER (SYSTEM)	120Vac, 60 Hz	DETECTOR FUNCTION	Peak (PK) Average (AV)
ENVIRONMENTAL CONDITIONS	24deg. C, 86%RH	TESTED BY	Chad Lee

ANTENNA POLARITY & TEST DISTANCE: HORIZONTAL AT 3 M								
NO.	FREQ. (MHz)	EMISSION LEVEL (dBuV/m)	LIMIT (dBuV/m)	MARGIN (dB)	ANTENNA HEIGHT (m)	TABLE ANGLE (Degree)	RAW VALUE (dBuV)	CORRECTION FACTOR (dB/m)
1	*5300.00	103.7 PK			1.28 H	144	66.18	37.56
2	*5300.00	90.6 AV			1.28 H	144	53.00	37.56
3	#10360.00	57.9 PK	68.3	-10.4	1.00 H	196	10.63	47.25

ANTENNA POLARITY & TEST DISTANCE: VERTICAL AT 3 M								
NO.	FREQ. (MHz)	EMISSION LEVEL (dBuV/m)	LIMIT (dBuV/m)	MARGIN (dB)	ANTENNA HEIGHT (m)	TABLE ANGLE (Degree)	RAW VALUE (dBuV)	CORRECTION FACTOR (dB/m)
1	*5300.00	107.1 PK			1.18 V	189	69.56	37.56
2	*5300.00	93.5 AV			1.18 V	189	55.98	37.56
3	10600.00	57.6 PK	74.0	-16.4	1.00 V	194	9.86	47.69
4	10600.00	43.0 AV	54.0	-11.0	1.00 V	194	-4.73	47.69

REMARKS:

1. Emission level (dBuV/m) = Raw Value (dBuV) + Correction Factor (dB/m).
2. Correction Factor (dB/m) = Antenna Factor (dB/m) + Cable Factor (dB).
3. The other emission levels were very low against the limit.
4. Margin value = Emission level – Limit value.
5. “ * “: Fundamental frequency.



EUT TEST CONDITION		MEASUREMENT DETAIL	
CHANNEL	Channel 64	FREQUENCY RANGE	1 ~ 40GHz
INPUT POWER (SYSTEM)	120Vac, 60 Hz	DETECTOR FUNCTION	Peak (PK) Average (AV)
ENVIRONMENTAL CONDITIONS	24deg. C, 86%RH	TESTED BY	Chad Lee

ANTENNA POLARITY & TEST DISTANCE: HORIZONTAL AT 3 M								
NO.	FREQ. (MHz)	EMISSION LEVEL (dBuV/m)	LIMIT (dBuV/m)	MARGIN (dB)	ANTENNA HEIGHT (m)	TABLE ANGLE (Degree)	RAW VALUE (dBuV)	CORRECTION FACTOR (dB/m)
1	*5320.00	103.3 PK			1.26 H	148	65.67	37.58
2	*5320.00	90.1 AV			1.26 H	148	52.53	37.58
3	5350.00	52.3 PK	74.0	-21.7	1.26 H	148	14.70	37.62
4	5350.00	42.4 AV	54.0	-11.6	1.26 H	148	4.82	37.62
5	10640.00	56.2 PK	74.0	-17.8	1.00 H	164	8.46	47.75
6	10640.00	41.7 AV	54.0	-12.3	1.00 H	164	-6.06	47.75
ANTENNA POLARITY & TEST DISTANCE: VERTICAL AT 3 M								
NO.	FREQ. (MHz)	EMISSION LEVEL (dBuV/m)	LIMIT (dBuV/m)	MARGIN (dB)	ANTENNA HEIGHT (m)	TABLE ANGLE (Degree)	RAW VALUE (dBuV)	CORRECTION FACTOR (dB/m)
1	*5320.00	106.8 PK			1.28 V	266	69.17	37.58
2	*5320.00	94.8 AV			1.28 V	266	57.22	37.58
3	5350.00	54.7 PK	74.0	-19.4	1.28 V	266	17.03	37.62
4	5350.00	44.9 AV	54.0	-9.1	1.28 V	266	7.26	37.62
5	10640.00	57.1 PK	74.0	-16.9	1.00 V	144	9.34	47.75
6	10640.00	43.3 AV	54.0	-10.7	1.00 V	144	-4.47	47.75

REMARKS:

1. Emission level (dBuV/m) = Raw Value (dBuV) + Correction Factor (dB/m).
2. Correction Factor (dB/m) = Antenna Factor (dB/m) + Cable Factor (dB).
3. The other emission levels were very low against the limit.
4. Margin value = Emission level – Limit value.
5. “ * “: Fundamental frequency.



A D T

EUT TEST CONDITION		MEASUREMENT DETAIL	
CHANNEL	Channel 100	FREQUENCY RANGE	1 ~ 40GHz
INPUT POWER (SYSTEM)	120Vac, 60 Hz	DETECTOR FUNCTION	Peak (PK) Average (AV)
ENVIRONMENTAL CONDITIONS	24deg. C, 86%RH	TESTED BY	Chad Lee

ANTENNA POLARITY & TEST DISTANCE: HORIZONTAL AT 3 M								
NO.	FREQ. (MHz)	EMISSION LEVEL (dBuV/m)	LIMIT (dBuV/m)	MARGIN (dB)	ANTENNA HEIGHT (m)	TABLE ANGLE (Degree)	RAW VALUE (dBuV)	CORRECTION FACTOR (dB/m)
1	5460.00	50.3 PK	74.0	-23.7	1.28 H	319	12.46	37.86
2	5460.00	35.2 AV	54.0	-18.8	1.28 H	319	-2.65	37.86
3	#5470.00	53.2 PK	68.3	-15.1	1.28 H	319	15.35	37.89
4	*5500.00	102.9 PK			1.28 H	319	64.87	37.98
5	*5500.00	88.4 AV			1.28 H	319	50.41	37.98
6	11000.00	58.0 PK	74.0	-16.0	1.00 H	47	9.60	48.39
7	11000.00	47.6 AV	54.0	-6.4	1.00 H	47	-0.76	48.39
ANTENNA POLARITY & TEST DISTANCE: VERTICAL AT 3 M								
NO.	FREQ. (MHz)	EMISSION LEVEL (dBuV/m)	LIMIT (dBuV/m)	MARGIN (dB)	ANTENNA HEIGHT (m)	TABLE ANGLE (Degree)	RAW VALUE (dBuV)	CORRECTION FACTOR (dB/m)
1	5460.00	51.3 PK	74.0	-22.8	1.21 V	7	13.39	37.86
2	5460.00	37.7 AV	54.0	-16.3	1.21 V	7	-0.20	37.86
3	#5470.00	57.6 PK	68.3	-10.7	1.21 V	7	19.71	37.89
4	*5500.00	105.2 PK			1.21 V	7	67.24	37.98
5	*5500.00	92.2 AV			1.21 V	7	54.21	37.98
6	11000.00	58.0 PK	74.0	-16.0	1.00 V	48	9.59	48.39
7	11000.00	43.2 AV	54.0	-10.8	1.00 V	48	-5.18	48.39

REMARKS:

1. Emission level (dBuV/m) = Raw Value (dBuV) + Correction Factor (dB/m).
2. Correction Factor (dB/m) = Antenna Factor (dB/m) + Cable Factor (dB).
3. The other emission levels were very low against the limit.
4. Margin value = Emission level – Limit value.
5. “ * “: Fundamental frequency.
6. “#”:The radiated frequency is out the restricted band.



A D T

EUT TEST CONDITION		MEASUREMENT DETAIL	
CHANNEL	Channel 116	FREQUENCY RANGE	1 ~ 40GHz
INPUT POWER (SYSTEM)	120Vac, 60 Hz	DETECTOR FUNCTION	Peak (PK) Average (AV)
ENVIRONMENTAL CONDITIONS	24deg. C, 86%RH	TESTED BY	Chad Lee

ANTENNA POLARITY & TEST DISTANCE: HORIZONTAL AT 3 M								
NO.	FREQ. (MHz)	EMISSION LEVEL (dBuV/m)	LIMIT (dBuV/m)	MARGIN (dB)	ANTENNA HEIGHT (m)	TABLE ANGLE (Degree)	RAW VALUE (dBuV)	CORRECTION FACTOR (dB/m)
1	*5580.00	103.0 PK			1.23 H	289	64.92	38.11
2	*5580.00	90.4 AV			1.23 H	289	52.33	38.11
3	11600.00	57.6 PK	74.0	-16.4	1.00 H	133	9.42	48.21
4	11600.00	46.2 AV	54.0	-7.8	1.00 H	133	-1.97	48.21
ANTENNA POLARITY & TEST DISTANCE: VERTICAL AT 3 M								
NO.	FREQ. (MHz)	EMISSION LEVEL (dBuV/m)	LIMIT (dBuV/m)	MARGIN (dB)	ANTENNA HEIGHT (m)	TABLE ANGLE (Degree)	RAW VALUE (dBuV)	CORRECTION FACTOR (dB/m)
1	*5580.00	105.1 PK			1.19 V	16	67.01	38.11
2	*5580.00	92.1 AV			1.19 V	16	54.00	38.11
3	11600.00	57.3 PK	74.0	-16.7	1.00 V	163	9.12	48.21
4	11600.00	42.9 AV	54.0	-11.1	1.00 V	163	-5.27	48.21

REMARKS:

1. Emission level (dBuV/m) = Raw Value (dBuV) + Correction Factor (dB/m).
2. Correction Factor (dB/m) = Antenna Factor (dB/m) + Cable Factor (dB).
3. The other emission levels were very low against the limit.
4. Margin value = Emission level – Limit value.
5. “ * “: Fundamental frequency.



A D T

EUT TEST CONDITION		MEASUREMENT DETAIL	
CHANNEL	Channel 140	FREQUENCY RANGE	1 ~ 40GHz
INPUT POWER (SYSTEM)	120Vac, 60 Hz	DETECTOR FUNCTION	Peak (PK) Average (AV)
ENVIRONMENTAL CONDITIONS	24deg. C, 86%RH	TESTED BY	Chad Lee

ANTENNA POLARITY & TEST DISTANCE: HORIZONTAL AT 3 M								
NO.	FREQ. (MHz)	EMISSION LEVEL (dBuV/m)	LIMIT (dBuV/m)	MARGIN (dB)	ANTENNA HEIGHT (m)	TABLE ANGLE (Degree)	RAW VALUE (dBuV)	CORRECTION FACTOR (dB/m)
1	*5700.00	103.4 PK			1.31 H	16	65.13	38.27
2	*5700.00	90.4 AV			1.31 H	16	52.14	38.27
3	#5725.00	62.2 PK	68.3	-11.8	1.31 H	16	23.88	38.31
4	11400.00	57.6 PK	74.0	-16.4	1.00 H	6	9.36	48.27
5	11400.00	47.5 AV	54.0	-6.5	1.00 H	6	-0.73	48.27
ANTENNA POLARITY & TEST DISTANCE: VERTICAL AT 3 M								
NO.	FREQ. (MHz)	EMISSION LEVEL (dBuV/m)	LIMIT (dBuV/m)	MARGIN (dB)	ANTENNA HEIGHT (m)	TABLE ANGLE (Degree)	RAW VALUE (dBuV)	CORRECTION FACTOR (dB/m)
1	*5700.00	106.5 PK			1.25 V	11	68.21	38.27
2	*5700.00	93.5 AV			1.25 V	11	55.23	38.27
3	#5725.00	64.2 PK	68.3	-9.8	1.25 V	11	25.88	38.31
4	11400.00	57.6 PK	74.0	-16.4	1.00 V	148	9.35	48.27
5	11400.00	42.3 AV	54.0	-11.8	1.00 V	148	-6.02	48.27

REMARKS:

1. Emission level (dBuV/m) = Raw Value (dBuV) + Correction Factor (dB/m).
2. Correction Factor (dB/m) = Antenna Factor (dB/m) + Cable Factor (dB).
3. The other emission levels were very low against the limit.
4. Margin value = Emission level – Limit value.
5. “ * “: Fundamental frequency.
6. “#”:The radiated frequency is out the restricted band.



A D T

802.11n (40MHz): 2TX

EUT TEST CONDITION		MEASUREMENT DETAIL	
CHANNEL	Channel 38	FREQUENCY RANGE	1 ~ 40GHz
INPUT POWER (SYSTEM)	120Vac, 60 Hz	DETECTOR FUNCTION	Peak (PK) Average (AV)
ENVIRONMENTAL CONDITIONS	24deg. C, 86%RH	TESTED BY	Chad Lee

ANTENNA POLARITY & TEST DISTANCE: HORIZONTAL AT 3 M								
NO.	FREQ. (MHz)	EMISSION LEVEL (dBuV/m)	LIMIT (dBuV/m)	MARGIN (dB)	ANTENNA HEIGHT (m)	TABLE ANGLE (Degree)	RAW VALUE (dBuV)	CORRECTION FACTOR (dB/m)
1	5150.00	67.8 PK	74.0	-6.2	1.28 H	312	28.64	39.20
2	5150.00	48.1 AV	54.0	-5.9	1.28 H	312	8.91	39.20
3	*5190.00	102.1 PK			1.28 H	312	62.84	39.26
4	*5190.00	82.7 AV			1.28 H	312	43.43	39.26
5	#10380.00	56.7 PK	68.3	-11.6	1.00 H	15	9.14	47.59
ANTENNA POLARITY & TEST DISTANCE: VERTICAL AT 3 M								
NO.	FREQ. (MHz)	EMISSION LEVEL (dBuV/m)	LIMIT (dBuV/m)	MARGIN (dB)	ANTENNA HEIGHT (m)	TABLE ANGLE (Degree)	RAW VALUE (dBuV)	CORRECTION FACTOR (dB/m)
1	5150.00	68.9 PK	74.0	-5.1	1.19 V	6	29.73	39.20
2	5150.00	50.5 AV	54.0	-3.5	1.19 V	6	11.29	39.20
3	*5190.00	103.3 PK			1.19 V	6	64.01	39.26
4	*5190.00	83.5 AV			1.19 V	6	44.25	39.26
5	#10380.00	56.8 PK	68.3	-11.5	1.00 V	16	9.20	47.59

REMARKS:

1. Emission level (dBuV/m) = Raw Value (dBuV) + Correction Factor (dB/m).
2. Correction Factor (dB/m) = Antenna Factor (dB/m) + Cable Factor (dB).
3. The other emission levels were very low against the limit.
4. Margin value = Emission level – Limit value.
5. “ * “: Fundamental frequency.
6. "#":The radiated frequency is out the restricted band.



A D T

EUT TEST CONDITION		MEASUREMENT DETAIL	
CHANNEL	Channel 46	FREQUENCY RANGE	1 ~ 40GHz
INPUT POWER (SYSTEM)	120Vac, 60 Hz	DETECTOR FUNCTION	Peak (PK) Average (AV)
ENVIRONMENTAL CONDITIONS	24deg. C, 86%RH	TESTED BY	Chad Lee

ANTENNA POLARITY & TEST DISTANCE: HORIZONTAL AT 3 M								
NO.	FREQ. (MHz)	EMISSION LEVEL (dBuV/m)	LIMIT (dBuV/m)	MARGIN (dB)	ANTENNA HEIGHT (m)	TABLE ANGLE (Degree)	RAW VALUE (dBuV)	CORRECTION FACTOR (dB/m)
1	*5230.00	99.1 PK			1.28 H	16	59.80	39.32
2	*5230.00	79.8 AV			1.28 H	16	40.52	39.32
3	5350.00	47.6 PK	74.0	-26.4	1.28 H	16	8.15	39.49
4	5350.00	38.1 AV	54.0	-15.9	1.28 H	16	-1.35	39.49
5	#10460.00	58.8 PK	68.3	-9.5	1.00 H	114	11.33	47.48
ANTENNA POLARITY & TEST DISTANCE: VERTICAL AT 3 M								
NO.	FREQ. (MHz)	EMISSION LEVEL (dBuV/m)	LIMIT (dBuV/m)	MARGIN (dB)	ANTENNA HEIGHT (m)	TABLE ANGLE (Degree)	RAW VALUE (dBuV)	CORRECTION FACTOR (dB/m)
1	*5230.00	101.2 PK			1.39 V	127	61.90	39.32
2	*5230.00	81.2 AV			1.39 V	127	41.84	39.32
3	5350.00	49.9 PK	74.0	-24.1	1.39 V	127	10.38	39.49
4	5350.00	40.4 AV	54.0	-13.7	1.39 V	127	0.86	39.49
5	#10460.00	56.8 PK	68.3	-11.5	1.00 V	199	9.33	47.48

REMARKS:

1. Emission level (dBuV/m) = Raw Value (dBuV) + Correction Factor (dB/m).
2. Correction Factor (dB/m) = Antenna Factor (dB/m) + Cable Factor (dB).
3. The other emission levels were very low against the limit.
4. Margin value = Emission level – Limit value.
5. " * ": Fundamental frequency.
6. "#":The radiated frequency is out the restricted band.



A D T

EUT TEST CONDITION		MEASUREMENT DETAIL	
CHANNEL	Channel 54	FREQUENCY RANGE	1 ~ 40GHz
INPUT POWER (SYSTEM)	120Vac, 60 Hz	DETECTOR FUNCTION	Peak (PK) Average (AV)
ENVIRONMENTAL CONDITIONS	24deg. C, 86%RH	TESTED BY	Chad Lee

ANTENNA POLARITY & TEST DISTANCE: HORIZONTAL AT 3 M								
NO.	FREQ. (MHz)	EMISSION LEVEL (dBuV/m)	LIMIT (dBuV/m)	MARGIN (dB)	ANTENNA HEIGHT (m)	TABLE ANGLE (Degree)	RAW VALUE (dBuV)	CORRECTION FACTOR (dB/m)
1	5150.00	46.3 PK	74.0	-27.7	1.28 H	6	7.10	39.20
2	5150.00	36.6 AV	54.0	-17.4	1.28 H	6	-2.63	39.20
3	*5270.00	98.1 PK			1.28 H	6	58.75	39.37
4	*5270.00	78.5 AV			1.28 H	6	39.08	39.37
5	#10540.00	57.3 PK	68.3	-11.0	1.00 H	114	9.98	47.36
ANTENNA POLARITY & TEST DISTANCE: VERTICAL AT 3 M								
NO.	FREQ. (MHz)	EMISSION LEVEL (dBuV/m)	LIMIT (dBuV/m)	MARGIN (dB)	ANTENNA HEIGHT (m)	TABLE ANGLE (Degree)	RAW VALUE (dBuV)	CORRECTION FACTOR (dB/m)
1	5150.00	49.3 PK	74.0	-24.7	1.17 V	349	10.14	39.20
2	5150.00	39.1 AV	54.0	-14.9	1.17 V	349	-0.08	39.20
3	*5270.00	100.9 PK			1.17 V	349	61.54	39.37
4	*5270.00	80.7 AV			1.17 V	349	41.33	39.37
5	#10540.00	57.7 PK	68.3	-10.6	1.00 V	148	10.38	47.36

REMARKS:

1. Emission level (dBuV/m) = Raw Value (dBuV) + Correction Factor (dB/m).
2. Correction Factor (dB/m) = Antenna Factor (dB/m) + Cable Factor (dB).
3. The other emission levels were very low against the limit.
4. Margin value = Emission level – Limit value.
5. “ * “: Fundamental frequency.
6. "#":The radiated frequency is out the restricted band.



A D T

EUT TEST CONDITION		MEASUREMENT DETAIL	
CHANNEL	Channel 62	FREQUENCY RANGE	1 ~ 40GHz
INPUT POWER (SYSTEM)	120Vac, 60 Hz	DETECTOR FUNCTION	Peak (PK) Average (AV)
ENVIRONMENTAL CONDITIONS	24deg. C, 86%RH	TESTED BY	Chad Lee

ANTENNA POLARITY & TEST DISTANCE: HORIZONTAL AT 3 M								
NO.	FREQ. (MHz)	EMISSION LEVEL (dBuV/m)	LIMIT (dBuV/m)	MARGIN (dB)	ANTENNA HEIGHT (m)	TABLE ANGLE (Degree)	RAW VALUE (dBuV)	CORRECTION FACTOR (dB/m)
1	*5310.00	98.6 PK			1.29 H	253	59.20	39.43
2	*5310.00	78.4 AV			1.29 H	253	38.98	39.43
3	5350.00	52.4 PK	74.0	-21.6	1.29 H	253	12.87	39.49
4	5350.00	41.8 AV	54.0	-12.2	1.29 H	253	2.34	39.49
5	10620.00	57.0 PK	74.0	-17.0	1.00 H	159	9.81	47.21
6	10620.00	46.6 AV	54.0	-7.4	1.00 H	159	-0.59	47.21
ANTENNA POLARITY & TEST DISTANCE: VERTICAL AT 3 M								
NO.	FREQ. (MHz)	EMISSION LEVEL (dBuV/m)	LIMIT (dBuV/m)	MARGIN (dB)	ANTENNA HEIGHT (m)	TABLE ANGLE (Degree)	RAW VALUE (dBuV)	CORRECTION FACTOR (dB/m)
1	*5310.00	100.7 PK			1.25 V	16	61.27	39.43
2	*5310.00	80.6 AV			1.25 V	16	41.14	39.43
3	5350.00	54.3 PK	74.0	-19.8	1.25 V	16	14.76	39.49
4	5350.00	43.9 AV	54.0	-10.1	1.25 V	16	4.38	39.49
5	10620.00	56.5 PK	74.0	-17.5	1.00 V	14	9.30	47.21
6	10620.00	41.6 AV	54.0	-12.4	1.00 V	14	-5.65	47.21

REMARKS:

1. Emission level (dBuV/m) = Raw Value (dBuV) + Correction Factor (dB/m).
2. Correction Factor (dB/m) = Antenna Factor (dB/m) + Cable Factor (dB).
3. The other emission levels were very low against the limit.
4. Margin value = Emission level – Limit value.
5. “ * “: Fundamental frequency.



A D T

EUT TEST CONDITION		MEASUREMENT DETAIL	
CHANNEL	Channel 102	FREQUENCY RANGE	1 ~ 40GHz
INPUT POWER (SYSTEM)	120Vac, 60 Hz	DETECTOR FUNCTION	Peak (PK) Average (AV)
ENVIRONMENTAL CONDITIONS	24deg. C, 86%RH	TESTED BY	Chad Lee

ANTENNA POLARITY & TEST DISTANCE: HORIZONTAL AT 3 M								
NO.	FREQ. (MHz)	EMISSION LEVEL (dBuV/m)	LIMIT (dBuV/m)	MARGIN (dB)	ANTENNA HEIGHT (m)	TABLE ANGLE (Degree)	RAW VALUE (dBuV)	CORRECTION FACTOR (dB/m)
1	5460.00	51.8 PK	74.0	-22.2	1.19 H	23	12.08	39.75
2	5460.00	38.8 AV	54.0	-15.2	1.19 H	23	-0.95	39.75
3	#5470.00	62.1 PK	68.3	-6.2	1.19 H	23	22.35	39.78
4	*5510.00	97.1 PK			1.19 H	23	57.23	39.89
5	*5510.00	77.1 AV			1.19 H	23	37.19	39.89
6	11020.00	57.3 PK	74.0	-16.7	1.00 H	59	10.65	46.61
7	11020.00	41.4 AV	54.0	-12.6	1.00 H	59	-5.19	46.61
ANTENNA POLARITY & TEST DISTANCE: VERTICAL AT 3 M								
NO.	FREQ. (MHz)	EMISSION LEVEL (dBuV/m)	LIMIT (dBuV/m)	MARGIN (dB)	ANTENNA HEIGHT (m)	TABLE ANGLE (Degree)	RAW VALUE (dBuV)	CORRECTION FACTOR (dB/m)
1	5460.00	53.2 PK	74.0	-20.8	1.10 V	162	13.42	39.75
2	5460.00	41.0 AV	54.0	-13.0	1.10 V	162	1.21	39.75
3	#5470.00	66.4 PK	68.3	-1.9	1.10 V	162	26.58	39.78
4	*5510.00	100.4 PK			1.10 V	162	60.47	39.89
5	*5510.00	80.1 AV			1.10 V	162	40.25	39.89
6	11020.00	56.3 PK	74.0	-17.7	1.00 V	1	9.65	46.61
7	11020.00	41.0 AV	54.0	-13.0	1.00 V	1	-5.57	46.61

REMARKS:

1. Emission level (dBuV/m) = Raw Value (dBuV) + Correction Factor (dB/m).
2. Correction Factor (dB/m) = Antenna Factor (dB/m) + Cable Factor (dB).
3. The other emission levels were very low against the limit.
4. Margin value = Emission level – Limit value.
5. “ * “: Fundamental frequency.
6. “#”:The radiated frequency is out the restricted band.



A D T

EUT TEST CONDITION		MEASUREMENT DETAIL	
CHANNEL	Channel 110	FREQUENCY RANGE	1 ~ 40GHz
INPUT POWER (SYSTEM)	120Vac, 60 Hz	DETECTOR FUNCTION	Peak (PK) Average (AV)
ENVIRONMENTAL CONDITIONS	24deg. C, 86%RH	TESTED BY	Chad Lee

ANTENNA POLARITY & TEST DISTANCE: HORIZONTAL AT 3 M								
NO.	FREQ. (MHz)	EMISSION LEVEL (dBuV/m)	LIMIT (dBuV/m)	MARGIN (dB)	ANTENNA HEIGHT (m)	TABLE ANGLE (Degree)	RAW VALUE (dBuV)	CORRECTION FACTOR (dB/m)
1	*5550.00	98.4 PK			1.10 H	136	58.45	39.91
2	*5550.00	78.7 AV			1.10 H	136	38.83	39.91
3	11100.00	57.4 PK	74.0	-16.6	1.00 H	3	10.76	46.67
4	11100.00	48.0 AV	54.0	-6.0	1.00 H	3	1.36	46.67
ANTENNA POLARITY & TEST DISTANCE: VERTICAL AT 3 M								
NO.	FREQ. (MHz)	EMISSION LEVEL (dBuV/m)	LIMIT (dBuV/m)	MARGIN (dB)	ANTENNA HEIGHT (m)	TABLE ANGLE (Degree)	RAW VALUE (dBuV)	CORRECTION FACTOR (dB/m)
1	*5550.00	100.5 PK			1.23 V	18	60.57	39.91
2	*5550.00	80.0 AV			1.23 V	18	40.12	39.91
3	11100.00	57.4 PK	74.0	-16.6	1.00 V	113	10.76	46.67
4	11100.00	42.3 AV	54.0	-11.7	1.00 V	113	-4.38	46.67

REMARKS:

1. Emission level (dBuV/m) = Raw Value (dBuV) + Correction Factor (dB/m).
2. Correction Factor (dB/m) = Antenna Factor (dB/m) + Cable Factor (dB).
3. The other emission levels were very low against the limit.
4. Margin value = Emission level – Limit value.
5. “ * “: Fundamental frequency.



EUT TEST CONDITION		MEASUREMENT DETAIL	
CHANNEL	Channel 134	FREQUENCY RANGE	1 ~ 40GHz
INPUT POWER (SYSTEM)	120Vac, 60 Hz	DETECTOR FUNCTION	Peak (PK) Average (AV)
ENVIRONMENTAL CONDITIONS	24deg. C, 86%RH	TESTED BY	Chad Lee

ANTENNA POLARITY & TEST DISTANCE: HORIZONTAL AT 3 M								
NO.	FREQ. (MHz)	EMISSION LEVEL (dBuV/m)	LIMIT (dBuV/m)	MARGIN (dB)	ANTENNA HEIGHT (m)	TABLE ANGLE (Degree)	RAW VALUE (dBuV)	CORRECTION FACTOR (dB/m)
1	*5670.00	99.3 PK			1.08 H	152	59.29	39.96
2	*5670.00	79.0 AV			1.08 H	152	39.00	39.96
3	#5725.00	48.4 PK	68.3	-25.6	1.08 H	152	8.38	39.98
4	11340.00	58.7 PK	74.0	-15.3	1.00 H	14	11.67	47.04
5	11340.00	49.1 AV	54.0	-4.9	1.00 H	14	2.06	47.04
ANTENNA POLARITY & TEST DISTANCE: VERTICAL AT 3 M								
NO.	FREQ. (MHz)	EMISSION LEVEL (dBuV/m)	LIMIT (dBuV/m)	MARGIN (dB)	ANTENNA HEIGHT (m)	TABLE ANGLE (Degree)	RAW VALUE (dBuV)	CORRECTION FACTOR (dB/m)
1	*5670.00	100.8 PK			1.22 V	23	60.80	39.96
2	*5670.00	80.1 AV			1.22 V	23	40.14	39.96
3	#5725.00	50.1 PK	68.3	-24.0	1.22 V	23	10.07	39.98
4	11340.00	57.6 PK	74.0	-16.4	1.00 V	149	10.57	47.04
5	11340.00	42.3 AV	54.0	-11.7	1.00 V	149	-4.72	47.04

REMARKS:

1. Emission level (dBuV/m) = Raw Value (dBuV) + Correction Factor (dB/m).
2. Correction Factor (dB/m) = Antenna Factor (dB/m) + Cable Factor (dB).
3. The other emission levels were very low against the limit.
4. Margin value = Emission level – Limit value.
5. “ * “: Fundamental frequency.
6. “#”:The radiated frequency is out the restricted band.

BELOW 1GHz WORST-CASE DATA :

802.11n (20MHz): 2TX

EUT TEST CONDITION		MEASUREMENT DETAIL	
CHANNEL	Channel 52	FREQUENCY RANGE	Below 1000MHz
INPUT POWER (SYSTEM)	120Vac, 60 Hz	DETECTOR FUNCTION	Quasi-Peak
ENVIRONMENTAL CONDITIONS	25deg. C, 89%RH	TESTED BY	Chad Lee

ANTENNA POLARITY & TEST DISTANCE: HORIZONTAL AT 3 M								
NO.	FREQ. (MHz)	EMISSION LEVEL (dBuV/m)	LIMIT (dBuV/m)	MARGIN (dB)	ANTENNA HEIGHT (m)	TABLE ANGLE (Degree)	RAW VALUE (dBuV)	CORRECTION FACTOR (dB/m)
1	203.54	31.5 QP	43.5	-12.0	1.51 H	133	20.28	11.26
2	662.12	34.9 QP	46.0	-11.2	1.00 H	88	10.81	24.04
3	713.02	36.4 QP	46.0	-9.6	1.00 H	109	11.60	24.77
4	763.92	36.7 QP	46.0	-9.3	1.00 H	61	11.01	25.65
5	814.82	34.3 QP	46.0	-11.7	1.00 H	40	7.84	26.50
6	913.71	35.9 QP	46.0	-10.1	1.00 H	91	8.06	27.88
ANTENNA POLARITY & TEST DISTANCE: VERTICAL AT 3 M								
NO.	FREQ. (MHz)	EMISSION LEVEL (dBuV/m)	LIMIT (dBuV/m)	MARGIN (dB)	ANTENNA HEIGHT (m)	TABLE ANGLE (Degree)	RAW VALUE (dBuV)	CORRECTION FACTOR (dB/m)
1	43.09	31.7 QP	40.0	-8.3	1.00 V	355	17.67	14.05
2	498.76	35.6 QP	46.0	-10.4	1.00 V	172	14.58	21.01
3	663.58	29.5 QP	46.0	-16.5	1.00 V	88	5.40	24.06
4	713.02	29.6 QP	46.0	-16.4	1.00 V	307	4.86	24.77
5	763.44	32.7 QP	46.0	-13.3	1.00 V	271	7.08	25.64
6	899.17	32.8 QP	46.0	-13.2	1.00 V	244	5.06	27.72

REMARKS:

1. Emission level (dBuV/m) = Raw Value (dBuV) + Correction Factor (dB/m).
2. Correction Factor (dB/m) = Antenna Factor (dB/m) + Cable Factor (dB).
3. The other emission levels were very low against the limit.
4. Margin value = Emission level – Limit value.



A D T

EUT TEST CONDITION		MEASUREMENT DETAIL	
CHANNEL	Channel 100	FREQUENCY RANGE	Below 1000MHz
INPUT POWER (SYSTEM)	120Vac, 60 Hz	DETECTOR FUNCTION	Quasi-Peak
ENVIRONMENTAL CONDITIONS	25deg. C, 89%RH	TESTED BY	Chad Lee

ANTENNA POLARITY & TEST DISTANCE: HORIZONTAL AT 3 M								
NO.	FREQ. (MHz)	EMISSION LEVEL (dBuV/m)	LIMIT (dBuV/m)	MARGIN (dB)	ANTENNA HEIGHT (m)	TABLE ANGLE (Degree)	RAW VALUE (dBuV)	CORRECTION FACTOR (dB/m)
1	203.54	32.4 QP	43.5	-11.1	1.00 H	142	21.10	11.26
2	331.03	34.1 QP	46.0	-11.9	1.00 H	70	17.77	16.36
3	662.12	35.2 QP	46.0	-10.8	1.00 H	91	11.15	24.04
4	713.02	38.4 QP	46.0	-7.6	1.00 H	103	13.64	24.77
5	763.92	37.3 QP	46.0	-8.7	1.00 H	64	11.69	25.65
6	814.82	34.4 QP	46.0	-11.6	1.00 H	82	7.89	26.50
ANTENNA POLARITY & TEST DISTANCE: VERTICAL AT 3 M								
NO.	FREQ. (MHz)	EMISSION LEVEL (dBuV/m)	LIMIT (dBuV/m)	MARGIN (dB)	ANTENNA HEIGHT (m)	TABLE ANGLE (Degree)	RAW VALUE (dBuV)	CORRECTION FACTOR (dB/m)
1	496.82	35.4 QP	46.0	-10.6	1.00 V	154	14.46	20.95
2	663.58	31.0 QP	46.0	-15.0	1.50 V	100	6.93	24.06
3	713.02	32.1 QP	46.0	-13.9	1.00 V	280	7.37	24.77
4	763.92	32.5 QP	46.0	-13.5	1.00 V	127	6.81	25.65
5	895.78	30.2 QP	46.0	-15.8	1.00 V	82	2.51	27.67
6	914.20	29.7 QP	46.0	-16.3	1.20 V	73	1.82	27.89

REMARKS:

1. Emission level (dBuV/m) = Raw Value (dBuV) + Correction Factor (dB/m).
2. Correction Factor (dB/m) = Antenna Factor (dB/m) + Cable Factor (dB).
3. The other emission levels were very low against the limit.
4. Margin value = Emission level – Limit value.

4.2 CONDUCTED EMISSION MEASUREMENT

4.2.1 LIMITS OF CONDUCTED EMISSION MEASUREMENT

FREQUENCY OF EMISSION (MHz)	CONDUCTED LIMIT (dB μ V)	
	Quasi-peak	Average
0.15 ~ 0.5	66 to 56	56 to 46
0.5 ~ 5	56	46
5 ~ 30	60	50

- NOTE:** 1. The lower limit shall apply at the transition frequencies.
2. The limit decreases in line with the logarithm of the frequency in the range of 0.15 to 0.50MHz.
3. All emanations from a class A/B digital device or system, including any network of conductors and apparatus connected thereto, shall not exceed the level of field strengths specified above.

4.2.2 TEST INSTRUMENTS

DESCRIPTION & MANUFACTURER	MODEL NO.	SERIAL NO.	DATE OF CALIBRATION	DUE DATE OF CALIBRATION
Test Receiver ROHDE & SCHWARZ	ESCS30	100289	Nov. 19, 2011	Nov. 18, 2012
RF signal cable Woken	5D-FB	Cable-HYCO2-01	Dec. 22, 2011	Dec. 21, 2012
LISN ROHDE & SCHWARZ	ESH2-Z5	100100	Dec. 30, 2011	Dec. 29, 2012
LISN ROHDE & SCHWARZ	ESH3-Z5	100218	Dec. 08, 2011	Dec. 07, 2012
Software ADT	ADT_Cond_ V7.3.7	NA	NA	NA

- NOTE:** 1. The calibration interval of the above test instruments is 12 months and the calibrations are traceable to NML/ROC and NIST/USA.
2. The test was performed in HwaYa Shielded Room 2.
3. The VCCI Site Registration No. is C-2047.

4.2.3 TEST PROCEDURES

- The EUT was placed 0.4 meters from the conducting wall of the shielded room with EUT being connected to the power mains through a line impedance stabilization network (LISN). Other support units were connected to the power mains through another LISN. The two LISNs provide 50 ohm/ 50uH of coupling impedance for the measuring instrument.
- Both lines of the power mains connected to the EUT were checked for maximum conducted interference.
- The frequency range from 150kHz to 30MHz was searched. Emission levels under (Limit - 20dB) was not recorded.

NOTE: All modes of operation were investigated and the worst-case emissions are reported.

4.2.4 DEVIATION FROM TEST STANDARD

No deviation.

4.2.5 TEST SETUP

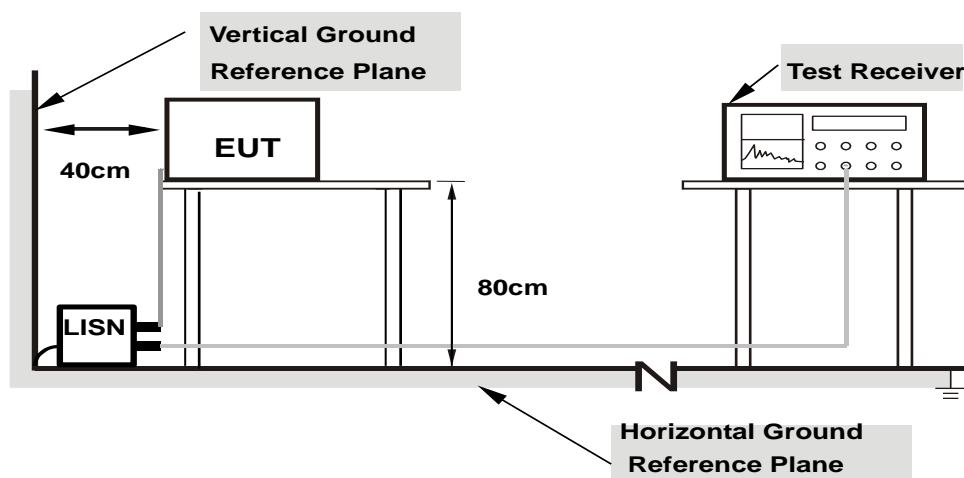

- Note:**
- Support units were connected to second LISN.
 - Both of LISNs (AMN) are 80 cm from EUT and at least 80 from other units and other metal planes

For the actual test configuration, please refer to the attached file (Test Setup Photo).

4.2.6 EUT OPERATING CONDITIONS

Same as 4.1.6.



4.2.7 TEST RESULTS

CONDUCTED WORST-CASE DATA :

802.11n (20MHz): 2TX

PHASE	Line 1	6dB BANDWIDTH	9kHz
CHANNEL	Channel 52		

No	Freq. [MHz]	Corr. Factor (dB)	Reading Value		Emission Level		Limit		Margin	
			[dB (uV)]		[dB (uV)]		[dB (uV)]		(dB)	
			Q.P.	AV.	Q.P.	AV.	Q.P.	AV.	Q.P.	AV.
1	0.38828	0.20	31.96	27.05	32.16	27.25	58.10	48.10	-25.94	-20.85
2	1.07031	0.23	23.09	16.98	23.32	17.21	56.00	46.00	-32.68	-28.79
3	1.81250	0.29	28.32	23.15	28.61	23.44	56.00	46.00	-27.39	-22.56
4	2.37891	0.32	27.83	18.16	28.15	18.48	56.00	46.00	-27.85	-27.52
5	11.63672	0.52	21.12	14.13	21.64	14.65	60.00	50.00	-38.36	-35.35
6	18.37891	0.69	27.60	22.19	28.29	22.88	60.00	50.00	-31.71	-27.12

REMARKS:

1. Q.P. and AV. are abbreviations of quasi-peak and average individually.
2. The emission levels of other frequencies were very low against the limit.
3. Margin value = Emission level - Limit value
4. Correction factor = Insertion loss + Cable loss
5. Emission Level = Correction Factor + Reading Value.

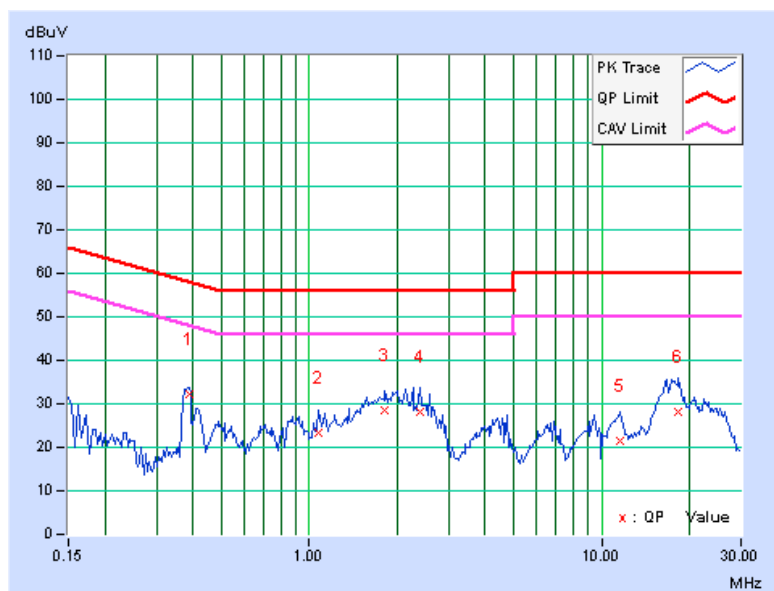



A D T

PHASE	Line 2	6dB BANDWIDTH	9kHz
CHANNEL	Channel 52		

No	Freq.	Corr. Factor	Reading Value		Emission Level		Limit		Margin	
	[MHz]		[dB (uV)]		[dB (uV)]		[dB (uV)]		(dB)	
			Q.P.	AV.	Q.P.	AV.	Q.P.	AV.	Q.P.	AV.
1	0.31406	0.17	26.15	20.49	26.32	20.66	59.86	49.86	-33.55	-29.21
2	0.38828	0.18	31.93	25.83	32.11	26.01	58.10	48.10	-25.99	-22.09
3	2.41016	0.29	23.25	15.01	23.54	15.30	56.00	46.00	-32.46	-30.70
4	4.36328	0.39	23.30	14.56	23.69	14.95	56.00	46.00	-32.31	-31.05
5	6.37109	0.46	23.11	16.34	23.57	16.80	60.00	50.00	-36.43	-33.20
6	16.72656	0.74	27.16	21.01	27.90	21.75	60.00	50.00	-32.10	-28.25

REMARKS:

1. Q.P. and AV. are abbreviations of quasi-peak and average individually.
2. The emission levels of other frequencies were very low against the limit.
3. Margin value = Emission level - Limit value
4. Correction factor = Insertion loss + Cable loss
5. Emission Level = Correction Factor + Reading Value.

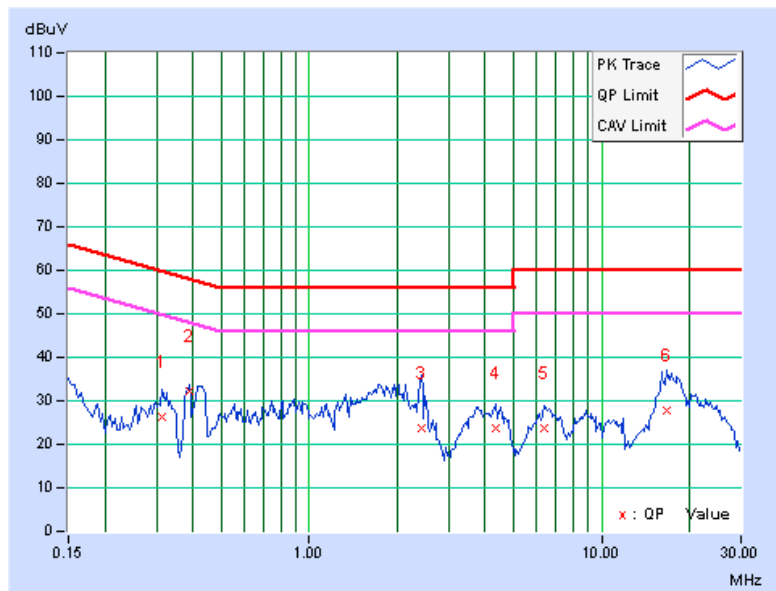

802.11n (20MHz): 2TX

PHASE	Line 1	6dB BANDWIDTH	9kHz
CHANNEL	Channel 100		

No	Freq. [MHz]	Corr. Factor (dB)	Reading Value [dB (uV)]		Emission Level [dB (uV)]		Limit [dB (uV)]		Margin (dB)	
			Q.P.	AV.	Q.P.	AV.	Q.P.	AV.	Q.P.	AV.
			1	0.38438	0.20	32.61	31.08	32.81	31.28	58.18
2	0.87656	0.22	21.35	16.41	21.57	16.63	56.00	46.00	-34.43	-29.37
3	2.00391	0.30	30.37	23.45	30.67	23.75	56.00	46.00	-25.33	-22.25
4	6.79297	0.43	17.92	10.30	18.35	10.73	60.00	50.00	-41.65	-39.27
5	11.55469	0.52	21.80	14.92	22.32	15.44	60.00	50.00	-37.68	-34.56
6	17.67188	0.67	29.41	24.49	30.08	25.16	60.00	50.00	-29.92	-24.84

REMARKS:

1. Q.P. and AV. are abbreviations of quasi-peak and average individually.
2. The emission levels of other frequencies were very low against the limit.
3. Margin value = Emission level - Limit value
4. Correction factor = Insertion loss + Cable loss
5. Emission Level = Correction Factor + Reading Value.

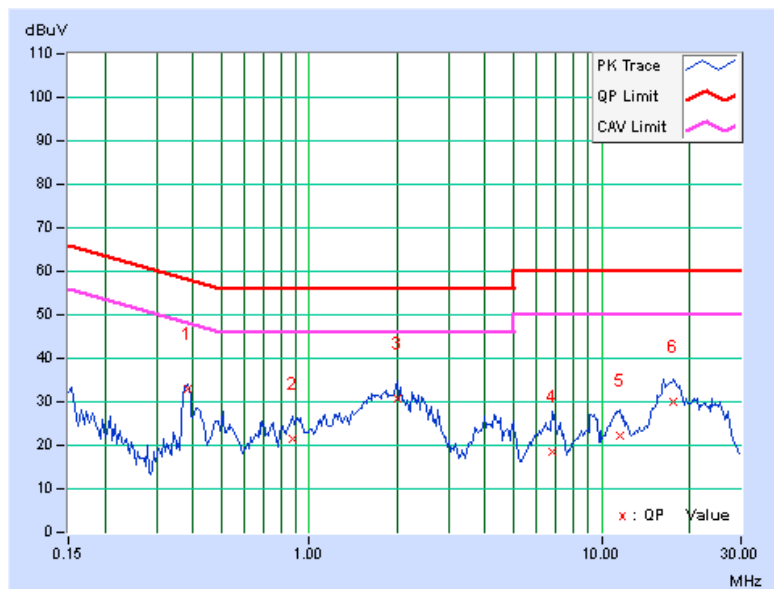



A D T

PHASE	Line 2	6dB BANDWIDTH	9kHz
CHANNEL	Channel 100		

No	Freq.	Corr. Factor	Reading Value		Emission Level		Limit		Margin	
	[MHz]		[dB (uV)]		[dB (uV)]		[dB (uV)]		(dB)	
			Q.P.	AV.	Q.P.	AV.	Q.P.	AV.	Q.P.	AV.
1	0.15391	0.17	27.12	21.44	27.29	21.61	65.79	55.79	-38.50	-34.18
2	0.38828	0.18	31.91	25.95	32.09	26.13	58.10	48.10	-26.01	-21.97
3	0.74766	0.19	19.52	15.37	19.71	15.56	56.00	46.00	-36.29	-30.44
4	1.87109	0.26	27.99	23.00	28.25	23.26	56.00	46.00	-27.75	-22.74
5	4.15234	0.38	23.61	15.63	23.99	16.01	56.00	46.00	-32.01	-29.99
6	17.76953	0.76	29.44	23.97	30.20	24.73	60.00	50.00	-29.80	-25.27

REMARKS:

1. Q.P. and AV. are abbreviations of quasi-peak and average individually.
2. The emission levels of other frequencies were very low against the limit.
3. Margin value = Emission level - Limit value
4. Correction factor = Insertion loss + Cable loss
5. Emission Level = Correction Factor + Reading Value.

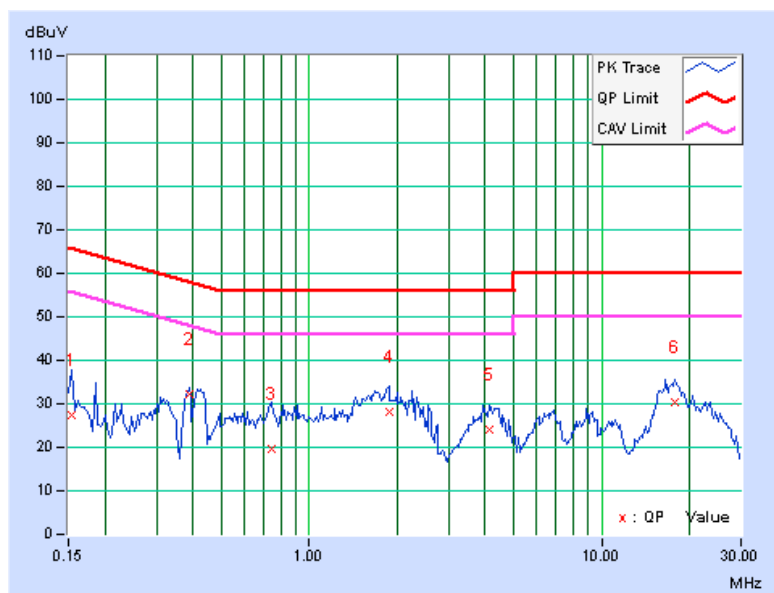

4.3 PEAK TRANSMIT POWER MEASUREMENT

4.3.1 LIMITS OF PEAK TRANSMIT POWER MEASUREMENT

FREQUENCY BAND	LIMIT
5.150 ~ 5.250GHz	The lesser of 50mW (17dBm) or 4dBm + 10logB
5.250 ~ 5.350GHz	The lesser of 250mW (24dBm) or 11dBm + 10logB
5.470 ~ 5.725GHz	The lesser of 250mW (24dBm) or 11dBm + 10logB

NOTE: Where B is the 26dB emission bandwidth in MHz.

4.3.2 TEST SETUP

FOR POWER OUTPUT MEASUREMENT

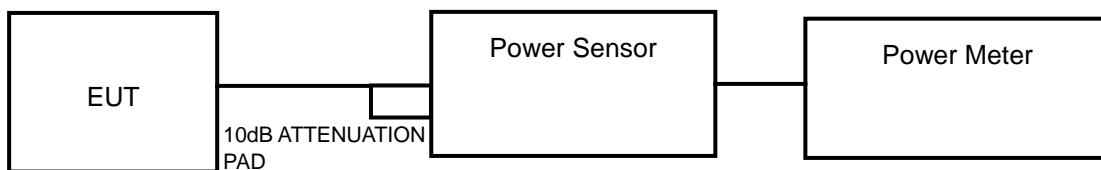

FOR 26dB BANDWIDTH

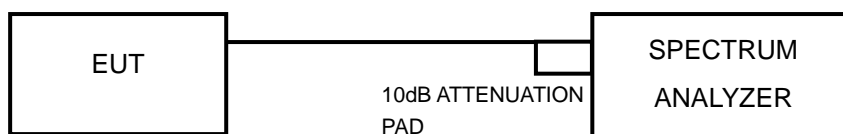

4.3.3 TEST INSTRUMENTS

Refer to section 4.1.3 to get information of above instrument.

4.3.4 TEST PROCEDURE

FOR AVERAGE POWER MEASUREMENT (Method-PM)

Method PM is used to perform output power measurement, trigger and gating function of wide band power meter is enabled to measure max output power of TX on burst. Duty factor is not added to measured value.

FOR 26dB BANDWIDTH

- 1) Set RBW = approximately 1% of the emission bandwidth.
- 2) Set the VBW > RBW.
- 3) Detector = Peak.
- 4) Trace mode = max hold.
- 5) Measure the maximum width of the emission that is 26 dB down from the peak of the emission. Compare this with the RBW setting of the analyzer. Readjust RBW and repeat measurement as needed until the RBW/EBW ratio is approximately 1%.

4.3.5 DEVIATION FROM TEST STANDARD

No deviation.

4.3.6 EUT OPERATING CONDITIONS

The software provided by client to enable the EUT under transmission condition continuously at specific channel frequencies individually.

4.3.7 TEST RESULTS

POWER OUTPUT: 802.11a: 1TX

CHANNEL	CHANNEL FREQUENCY (MHz)	AVERAGE POWER (mW)	AVERAGE POWER (dBm)	POWER LIMIT (dBm)	PASS/FAIL
36	5180	29.376	14.68	17	PASS
40	5200	29.854	14.75	17	PASS
48	5240	29.174	14.65	17	PASS
52	5260	41.400	16.17	24	PASS
60	5300	40.551	16.08	24	PASS
64	5320	40.179	16.04	24	PASS
100	5500	41.591	16.19	24	PASS
116	5580	40.644	16.09	24	PASS
140	5700	41.210	16.15	24	PASS

802.11n (20MHz): 1TX

CHANNEL	CHANNEL FREQUENCY (MHz)	AVERAGE POWER (mW)	AVERAGE POWER (dBm)	POWER LIMIT (dBm)	PASS/FAIL
36	5180	28.973	14.62	17	PASS
40	5200	29.376	14.68	17	PASS
48	5240	28.774	14.59	17	PASS
52	5260	41.879	16.22	24	PASS
60	5300	40.738	16.1	24	PASS
64	5320	40.551	16.08	24	PASS
100	5500	41.495	16.18	24	PASS
116	5580	41.783	16.21	24	PASS
140	5700	39.994	16.02	24	PASS

802.11n (40MHz): 1TX

CHANNEL	CHANNEL FREQUENCY (MHz)	AVERAGE POWER (mW)	AVERAGE POWER (dBm)	POWER LIMIT (dBm)	PASS/FAIL
38	5190	32.810	15.16	17	PASS
46	5230	31.915	15.04	17	PASS
54	5270	33.420	15.24	24	PASS
62	5310	32.063	15.06	24	PASS
102	5510	25.586	14.08	24	PASS
110	5550	26.002	14.15	24	PASS
134	5670	25.763	14.11	24	PASS



802.11n (20MHz): 2TX

CHAN.	CHAN. FREQ. (MHz)	AVERAGE POWER (dBm)		TOTAL POWER (mW)	TOTAL POWER (dBm)	POWER LIMIT (dBm)	PASS / FAIL
		CHAIN 0	CHAIN 1				
36	5180	11.29	11.52	27.6	14.4	17	PASS
40	5200	11.21	11.42	27.1	14.3	17	PASS
48	5240	11.18	11.36	26.8	14.3	17	PASS
52	5260	12.96	13.46	42.0	16.2	24	PASS
60	5300	12.78	13.42	40.9	16.1	24	PASS
64	5320	12.81	13.32	40.6	16.1	24	PASS
100	5500	12.97	13.56	42.5	16.3	24	PASS
116	5580	12.96	13.43	41.8	16.2	24	PASS
140	5700	12.85	13.26	40.5	16.1	24	PASS

802.11n (40MHz): 2TX

CHAN.	CHAN. FREQ. (MHz)	AVERAGE POWER (dBm)		TOTAL POWER (mW)	TOTAL POWER (dBm)	POWER LIMIT (dBm)	PASS / FAIL
		CHAIN 0	CHAIN 1				
38	5190	12.14	12.36	33.6	15.3	17	PASS
46	5230	11.92	12.58	33.7	15.3	17	PASS
54	5270	11.88	12.66	33.9	15.3	24	PASS
62	5310	11.84	12.64	33.6	15.3	24	PASS
102	5510	11.21	11.56	27.5	14.4	24	PASS
110	5550	11.18	11.64	27.7	14.4	24	PASS
134	5670	11.05	11.61	27.2	14.3	24	PASS



26dB BANDWIDTH: 802.11a: 1TX

CHANNEL	CHANNEL FREQUENCY (MHz)	26dBc BANDWIDTH (MHz)	PASS / FAIL
36	5180	25.22	PASS
40	5200	19.61	PASS
48	5240	20.60	PASS
52	5260	24.56	PASS
60	5300	25.13	PASS
64	5320	26.58	PASS
100	5500	27.75	PASS
116	5580	27.92	PASS
140	5700	24.86	PASS

802.11n (20MHz): 1TX

CHANNEL	CHANNEL FREQUENCY (MHz)	26dBc BANDWIDTH (MHz)	PASS / FAIL
36	5180	24.63	PASS
40	5200	24.65	PASS
48	5240	24.14	PASS
52	5260	28.53	PASS
60	5300	26.71	PASS
64	5320	27.56	PASS
100	5500	28.12	PASS
116	5580	27.37	PASS
140	5700	27.28	PASS

802.11n (40MHz): 1TX

CHANNEL	CHANNEL FREQUENCY (MHz)	26dBc BANDWIDTH (MHz)	PASS / FAIL
38	5190	63.06	PASS
46	5230	69.47	PASS
54	5270	75.44	PASS
62	5310	73.67	PASS
102	5510	64.49	PASS
110	5550	51.09	PASS
134	5670	60.88	PASS



A D T

802.11n (20MHz): 2TX

CHANNEL	CHANNEL FREQUENCY (MHz)	26dBc BANDWIDTH (MHz)		PASS / FAIL
		CHAIN 0	CHAIN 1	
36	5180	19.92	19.72	PASS
40	5200	19.97	19.77	PASS
48	5240	19.96	19.70	PASS
52	5260	19.85	19.86	PASS
60	5300	21.34	19.78	PASS
64	5320	19.89	19.85	PASS
100	5500	19.98	19.78	PASS
116	5580	19.87	19.83	PASS
140	5700	20.04	19.80	PASS

802.11n (40MHz): 2TX

CHANNEL	CHANNEL FREQUENCY (MHz)	26dBc BANDWIDTH (MHz)		PASS / FAIL
		CHAIN 0	CHAIN 1	
38	5190	46.35	40.75	PASS
46	5230	41.04	40.66	PASS
54	5270	41.41	40.53	PASS
62	5310	42.21	48.34	PASS
102	5510	41.13	40.82	PASS
110	5550	41.30	40.98	PASS
134	5670	42.66	41.17	PASS

4.4 PEAK POWER SPECTRAL DENSITY MEASUREMENT

4.4.1 LIMITS OF PEAK POWER SPECTRAL DENSITY MEASUREMENT

FREQUENCY BAND	LIMIT
5.150 ~ 5.250GHz	4dBm
5.250 ~ 5.350GHz	11dBm
5.470 ~ 5.725GHz	11dBm

4.4.2 TEST SETUP

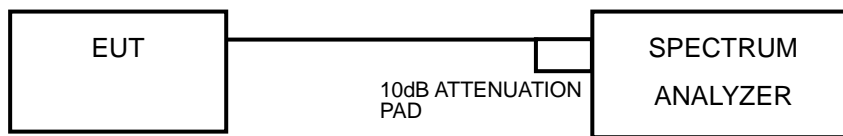

4.4.3 TEST INSTRUMENTS

Refer to section 4.1.3 to get information of above instrument.

4.4.4 TEST PROCEDURES

Using method SA-1 for 802.11a / 802.11n (20MHz): 1TX

- 1) Set span to encompass the entire emission bandwidth (EBW) of the signal.
- 2) Set RBW = 1 MHz, Set VBW \geq 3 MHz, Detector = RMS
- 3) Sweep time = auto, trigger set to "free run".
- 4) Trace average at least 100 traces in power averaging mode.
- 5) Record the max value

Using method SA-2 alternative for 802.11n (40MHz): 1TX / 802.11n (20MHz): 2TX / 802.11n (40MHz): 2TX

- 1) Set span to encompass the entire emission bandwidth (EBW) of the signal.
- 2) Set RBW = 1 MHz, Set VBW \geq 3 MHz, Detector = RMS
- 3) Sweep time = 32 second.
- 4) Trace average at least 100 traces in power averaging mode.
- 5) Record the max value and add 10 log (1/duty cycle)

4.4.5 DEVIATION FROM TEST STANDARD

No deviation.

4.4.6 EUT OPERATING CONDITIONS

Same as 4.3.6.



4.4.7 TEST RESULTS

802.11a: 1TX

CHANNEL	FREQUENCY (MHz)	PSD (dBm)	MAXIMUM LIMIT (dBm)	PASS/FAIL
36	5180	3.84	4	PASS
40	5200	3.69	4	PASS
48	5240	3.62	4	PASS
52	5260	5.76	11	PASS
60	5300	5.52	11	PASS
64	5320	6.03	11	PASS
100	5500	5.76	11	PASS
116	5580	6.05	11	PASS
140	5700	5.99	11	PASS

802.11n (20MHz): 1TX

CHANNEL	FREQUENCY (MHz)	PSD (dBm)	MAXIMUM LIMIT (dBm)	PASS/FAIL
36	5180	3.85	4	PASS
40	5200	3.85	4	PASS
48	5240	3.88	4	PASS
52	5260	5.44	11	PASS
60	5300	5.37	11	PASS
64	5320	5.32	11	PASS
100	5500	5.34	11	PASS
116	5580	5.62	11	PASS
140	5700	5.21	11	PASS

802.11n (40MHz): 1TX

CHANNEL	FREQUENCY (MHz)	PSD W/O DUTY FACTOR (dBm)	DUTY FACTOR	PSD WITH DUTY FACTOR (dBm)	MAXIMUM LIMIT (dBm)	PASS/FAIL
38	5190	2.06	0.18	2.24	4	PASS
46	5230	1.99	0.18	2.17	4	PASS
54	5270	1.91	0.18	2.09	11	PASS
62	5310	1.77	0.18	1.95	11	PASS
102	5510	1.21	0.18	1.39	11	PASS
110	5550	0.92	0.18	1.1	11	PASS
134	5670	1.23	0.18	1.41	11	PASS

NOTE: Refer to section 3.3 for duty cycle spectrum plot.

**802.11n (20MHz): 2TX**

CHAN.	CHAN. FREQ. (MHz)	PSD (dBm)		TOTAL PSD W/O DUTY FACTOR (dBm)	DUTY FACTOR	TOTAL PSD WITH DUTY FACTOR (dBm)	MAX. LIMIT (dBm)	PASS / FAIL
		CHAIN 0	CHAIN 1					
36	5180	0.48	0.94	3.707	0.17	3.877	4	PASS
40	5200	0.49	0.88	3.692	0.17	3.862	4	PASS
48	5240	0.51	0.85	3.69	0.17	3.86	4	PASS
52	5260	2.35	2.84	5.605	0.17	5.775	11	PASS
60	5300	2.21	2.86	5.527	0.17	5.697	11	PASS
64	5320	2.14	2.79	5.469	0.17	5.639	11	PASS
100	5500	2.17	2.99	5.548	0.17	5.718	11	PASS
116	5580	2.06	3.01	5.558	0.17	5.728	11	PASS
140	5700	2.04	2.79	5.41	0.17	5.58	11	PASS

NOTE:

1. Method 1 of power density measurement of KDB 662911 is using for calculating total power density. Total power density is summing entire spectra across corresponding frequency bins on the various outputs by computer.
2. Refer to section 3.3 for duty cycle spectrum plot.

802.11n (40MHz): 2TX

CHAN.	CHAN. FREQ. (MHz)	PSD (dBm)		TOTAL PSD W/O DUTY FACTOR (dBm)	DUTY FACTOR	TOTAL PSD WITH DUTY FACTOR (dBm)	MAX. LIMIT (dBm)	PASS / FAIL
		CHAIN 0	CHAIN 1					
38	5190	-1.72	-0.70	1.798	0.52	2.318	4	PASS
46	5230	-1.99	-0.66	1.718	0.52	2.238	4	PASS
54	5270	-1.82	-0.42	1.921	0.52	2.441	11	PASS
62	5310	-1.98	-0.18	1.959	0.52	2.479	11	PASS
102	5510	-2.61	-1.39	1.039	0.52	1.559	11	PASS
110	5550	-2.67	-1.49	0.971	0.52	1.491	11	PASS
134	5670	-2.65	-1.34	1.059	0.52	1.579	11	PASS

NOTE:

1. Method 1 of power density measurement of KDB 662911 is using for calculating total power density. Total power density is summing entire spectra across corresponding frequency bins on the various outputs by computer.
2. Refer to section 3.3 for duty cycle spectrum plot.

4.5 PEAK POWER EXCURSION MEASUREMENT

4.5.1 LIMITS OF PEAK POWER EXCURSION MEASUREMENT

Shall not exceed 13 dB.

4.5.2 TEST SETUP



4.5.3 TEST INSTRUMENTS

Refer to section 4.1.3 to get information of above instrument.

4.5.4 TEST PROCEDURE

- 1) Set RBW = 1 MHz, VBW \geq 3 MHz, Detector = peak.
- 2) Trace mode = max-hold. Allow the sweeps to continue until the trace stabilizes.
- 3) Use the peak search function to find the peak of the spectrum.
- 4) Measure the PPSD.
- 5) Compute the ratio of the maximum of the peak-max-hold spectrum to the PPSD.

4.5.5 DEVIATION FROM TEST STANDARD

No deviation.

4.5.6 EUT OPERATING CONDITIONS

Same as 4.2.6



A D T

4.5.7 TEST RESULTS

802.11a: 1TX

CHANNEL	CHANNEL FREQUENCY (MHz)	PEAK VALUE (dBm)	PPSD (dBm)	PEAK EXCURSION (dB)	LIMIT (dB)	PASS/FAIL
36	5180	14.49	3.84	10.65	13	PASS
40	5200	14.62	3.69	10.93	13	PASS
48	5240	14.53	3.62	10.91	13	PASS
52	5260	15.88	5.76	10.12	13	PASS
60	5300	16.10	5.52	10.58	13	PASS
64	5320	15.85	6.03	9.82	13	PASS
100	5500	16.16	5.76	10.4	13	PASS
116	5580	15.76	6.05	9.71	13	PASS
140	5700	15.73	5.99	9.74	13	PASS

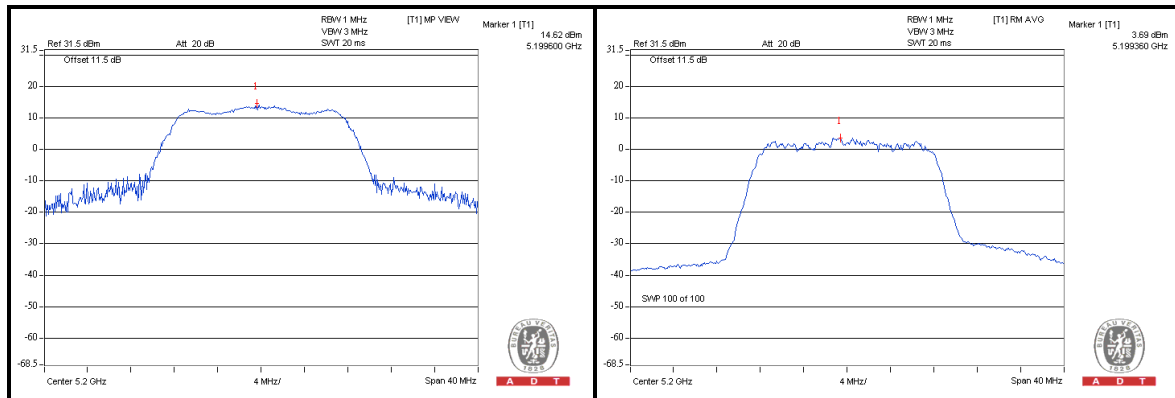



A D T

802.11n (20MHz): 1TX

CHANNEL	CHANNEL FREQUENCY (MHz)	PEAK VALUE (dBm)	PPSD (dBm)	PEAK EXCURSION (dB)	LIMIT (dB)	PASS/FAIL
36	5180	14.65	3.85	10.8	13	PASS
40	5200	13.92	3.85	10.7	13	PASS
48	5240	14.46	3.88	10.58	13	PASS
52	5260	16.05	5.44	10.61	13	PASS
60	5300	16.21	5.37	10.84	13	PASS
64	5320	15.98	5.32	10.66	13	PASS
100	5500	16.43	5.34	11.09	13	PASS
116	5580	16.07	5.62	10.45	13	PASS
132	5660	15.93	5.21	10.72	13	PASS
140	5700	14.65	3.85	10.8	13	PASS

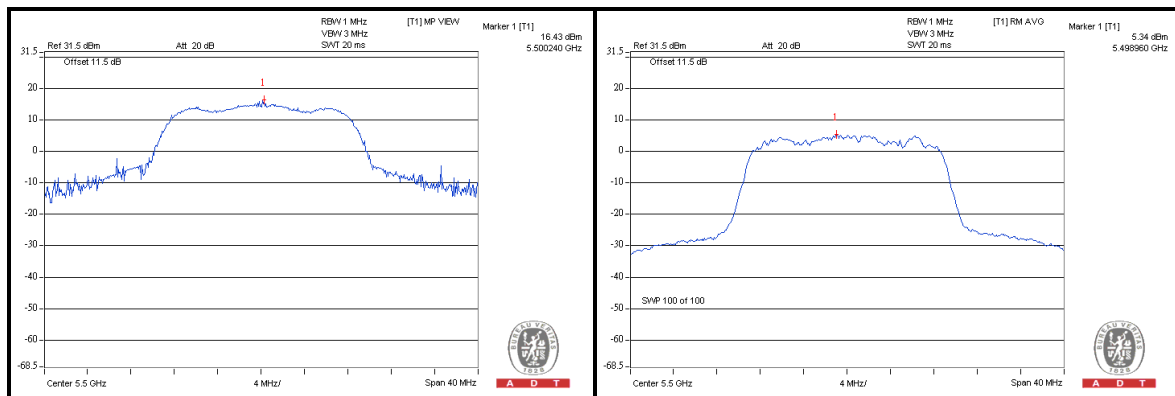



A D T

802.11n (40MHz): 1TX

CHANNEL	CHANNEL FREQUENCY (MHz)	PEAK VALUE (dBm)	PPSD WITHOUT DUTY FACTOR (dBm)	PPSD WITH DUTY FACTOR (dBm)	PEAK EXCURSION (dB)	LIMIT (dB)	PASS/FAIL
38	5190	11.05	2.06	2.24	8.81	13	PASS
46	5230	10.78	1.99	2.17	8.61	13	PASS
54	5270	11.02	1.91	2.09	8.93	13	PASS
62	5310	10.75	1.77	1.95	8.8	13	PASS
102	5510	10.10	1.21	1.39	8.71	13	PASS
110	5550	10.17	0.92	1.1	9.07	13	PASS
134	5670	10.19	1.23	1.41	8.78	13	PASS

NOTE: Refer to section 3.3 for duty cycle spectrum plot.

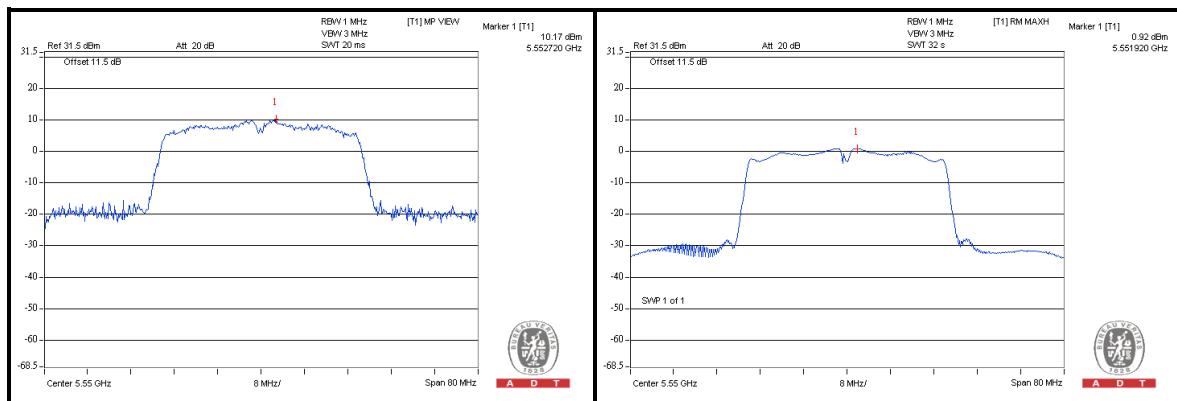



A D T

802.11n (20MHz): 2TX

CHAN.	CHAN. FREQ. (MHz)	PEAK VALUE (dBm)		PPSD WITHOUT DUTY FACTOR (dBm)		PPSD WITH DUTY FACTOR (dBm)		PEAK EXCURSION (dB)		LIMIT (dB)	PASS/FAIL
		CHAIN 0	CHAIN 1	CHAIN 0	CHAIN 1	CHAIN 0	CHAIN 1	CHAIN 0	CHAIN 1		
36	5180	10.41	11.27	0.48	0.94	0.65	1.11	9.76	10.16	13	PASS
40	5200	10.38	11.07	0.49	0.88	0.66	1.05	9.72	10.02	13	PASS
48	5240	10.19	11.17	0.51	0.85	0.68	1.02	9.51	10.15	13	PASS
52	5260	12.00	13.35	2.35	2.84	2.52	3.01	9.48	10.34	13	PASS
60	5300	11.95	13.17	2.21	2.86	2.38	3.03	9.57	10.14	13	PASS
64	5320	11.86	13.12	2.14	2.79	2.31	2.96	9.55	10.16	13	PASS
100	5500	12.12	13.34	2.17	2.99	2.34	3.16	9.78	10.18	13	PASS
116	5580	12.06	13.33	2.06	3.01	2.23	3.18	9.83	10.15	13	PASS
140	5700	11.87	12.86	2.04	2.79	2.21	2.96	9.66	9.9	13	PASS

NOTE: Refer to section 3.3 for duty cycle spectrum plot.

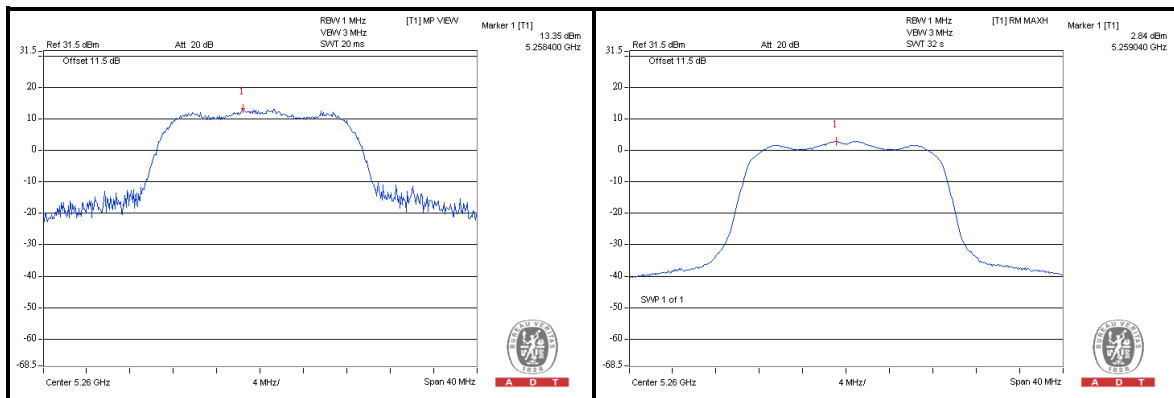



802.11n (40MHz): 2TX

CHAN.	CHAN. FREQ. (MHz)	PEAK VALUE (dBm)		PPSD WITHOUT DUTY FACTOR (dBm)		PPSD WITH DUTY FACTOR (dBm)		PEAK EXCURSION (dB)		LIMIT (dB)	PASS/FAIL
		CHAIN 0	CHAIN 1	CHAIN 0	CHAIN 1	CHAIN 0	CHAIN 1	CHAIN 0	CHAIN 1		
38	5190	7.59	9.79	-1.72	-0.70	-1.2	-0.18	8.79	9.97	13	PASS
46	5230	7.27	9.96	-1.99	-0.66	-1.47	-0.14	8.74	10.1	13	PASS
54	5270	7.11	10.23	-1.82	-0.42	-1.3	0.1	8.41	10.13	13	PASS
62	5310	7.39	10.18	-1.98	-0.18	-1.46	0.34	8.85	9.84	13	PASS
102	5510	6.6	8.91	-2.61	-1.39	-2.09	-0.87	8.69	9.78	13	PASS
110	5550	6.41	9	-2.67	-1.49	-2.15	-0.97	8.56	9.97	13	PASS
134	5670	6.67	8.89	-2.65	-1.34	-2.13	-0.82	8.8	9.71	13	PASS

NOTE: Refer to section 3.3 for duty cycle spectrum plot.

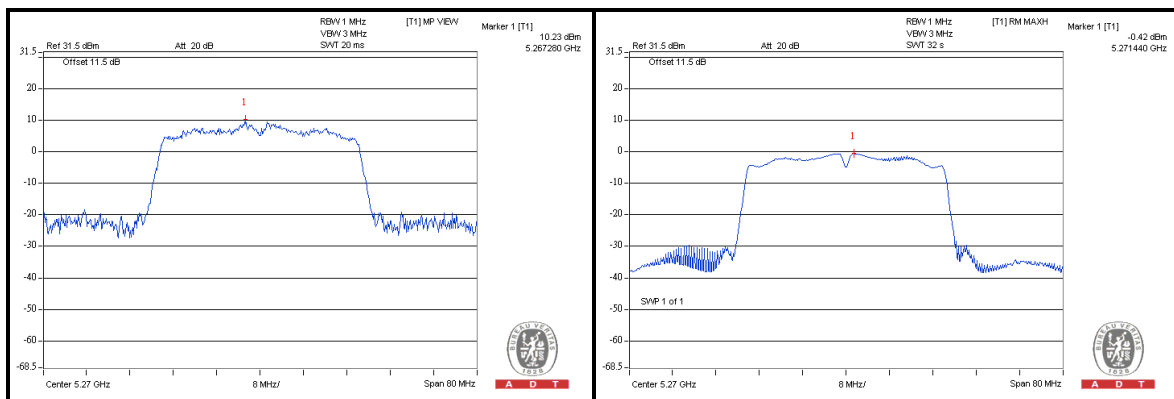

4.6 FREQUENCY STABILITY

4.6.1 LIMITS OF FREQUENCY STABILITY MEASUREMENT

The frequency of the carrier signal shall be maintained within band of operation

4.6.2 TEST SETUP

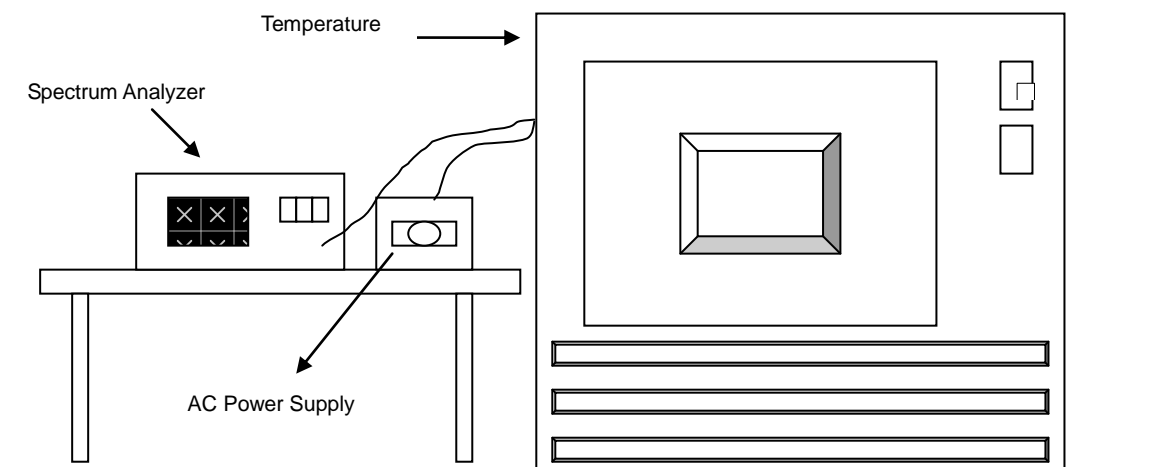

4.6.3 TEST INSTRUMENTS

Refer to section 4.1.3 to get information of above instrument.

4.6.4 TEST PROCEDURE

- a. The EUT was placed inside the environmental test chamber and powered by nominal AC voltage.
- b. Turn the EUT on and couple its output to a spectrum analyzer.
- c. Turn the EUT off and set the chamber to the highest temperature specified.
- d. Allow sufficient time (approximately 30 min) for the temperature of the chamber to stabilize, turn the EUT on and measure the operating frequency after 2, 5, and 10 minutes.
- e. Repeat step 2 and 3 with the temperature chamber set to the lowest temperature.
- f. The test chamber was allowed to stabilize at +20 degree C for a minimum of 30 minutes. The supply voltage was then adjusted on the EUT from 85% to 115% and the frequency record.

4.6.5 DEVIATION FROM TEST STANDARD

No deviation.

4.6.6 EUT OPERATING CONDITION

Set the EUT transmit at un-modulation mode to test frequency stability.



4.6.7 TEST RESULTS

FREQUENCY STABILITY VERSUS TEMP.									
OPERATING FREQUENCY: 5200MHz									
TEMP. (°C)	POWER SUPPLY (Vac)	0 MINUTE		2 MINUTE		5 MINUTE		10 MINUTE	
		Measured Frequency (MHz)	Frequency Drift (ppm)	Measured Frequency (MHz)	Frequency Drift (ppm)	Measured Frequency (MHz)	Frequency Drift (ppm)	Measured Frequency (MHz)	Frequency Drift (ppm)
50	110.0	5200.008504	1.635	5200.008567	1.648	5200.008413	1.618	5200.008763	1.685
40	110.0	5200.008732	1.679	5200.008753	1.683	5200.008961	1.723	5200.009001	1.731
30	110.0	5200.009868	1.898	5200.010064	1.935	5200.009604	1.847	5200.010128	1.948
20	110.0	5200.011065	2.128	5200.011339	2.181	5200.010881	2.093	5200.011425	2.197
10	110.0	5200.012992	2.498	5200.013282	2.554	5200.012905	2.482	5200.013108	2.521
0	110.0	5200.010906	2.097	5200.010951	2.106	5200.011303	2.174	5200.011146	2.143
-10	110.0	5200.009850	1.894	5200.009948	1.913	5200.010019	1.927	5200.010071	1.937
-20	110.0	5200.009174	1.764	5200.009750	1.875	5200.009406	1.809	5200.009519	1.831
-30	110.0	5200.007850	1.510	5200.007703	1.481	5200.008088	1.555	5200.008177	1.573

FREQUENCY STABILITY VERSUS VOLTAGE									
OPERATING FREQUENCY: 5200MHz									
TEMP. (°C)	POWER SUPPLY (Vac)	0 MINUTE		2 MINUTE		5 MINUTE		10 MINUTE	
		Measured Frequency (MHz)	Frequency Drift (ppm)	Measured Frequency (MHz)	Frequency Drift (ppm)	Measured Frequency (MHz)	Frequency Drift (ppm)	Measured Frequency (MHz)	Frequency Drift (ppm)
20	93.5	5200.009883	1.901	5200.009917	1.907	5200.010340	1.988	5200.010345	1.989
	110.0	5200.011065	2.128	5200.011339	2.181	5200.010881	2.093	5200.011425	2.197
	126.5	5200.013111	2.521	5200.013215	2.541	5200.013375	2.572	5200.012999	2.500

5. PHOTOGRAPHS OF THE TEST CONFIGURATION

Please refer to the attached file (Test Setup Photo).



6. INFORMATION ON THE TESTING LABORATORIES

We, Bureau Veritas Consumer Products Services (H.K.) Ltd., Taoyuan Branch, were founded in 1988 to provide our best service in EMC, Radio, Telecom and Safety consultation. Our laboratories are accredited and approved according to ISO/IEC 17025.

If you have any comments, please feel free to contact us at the following:

Linko EMC/RF Lab:

Tel: 886-2-26052180

Fax: 886-2-26051924

Hsin Chu EMC/RF Lab:

Tel: 886-3-5935343

Fax: 886-3-5935342

Hwa Ya EMC/RF/Safety Telecom Lab:

Tel: 886-3-3183232

Fax: 886-3-3270892

Email: service.adt@tw.bureauveritas.com

Web Site: www.adt.com.tw

The address and road map of all our labs can be found in our web site also.

7. APPENDIX A - MODIFICATIONS RECORDERS FOR ENGINEERING CHANGES TO THE EUT BY THE LAB

No modifications were made to the EUT by the lab during the test.

---END---