CAXA0 Rugged Tablet User Manual

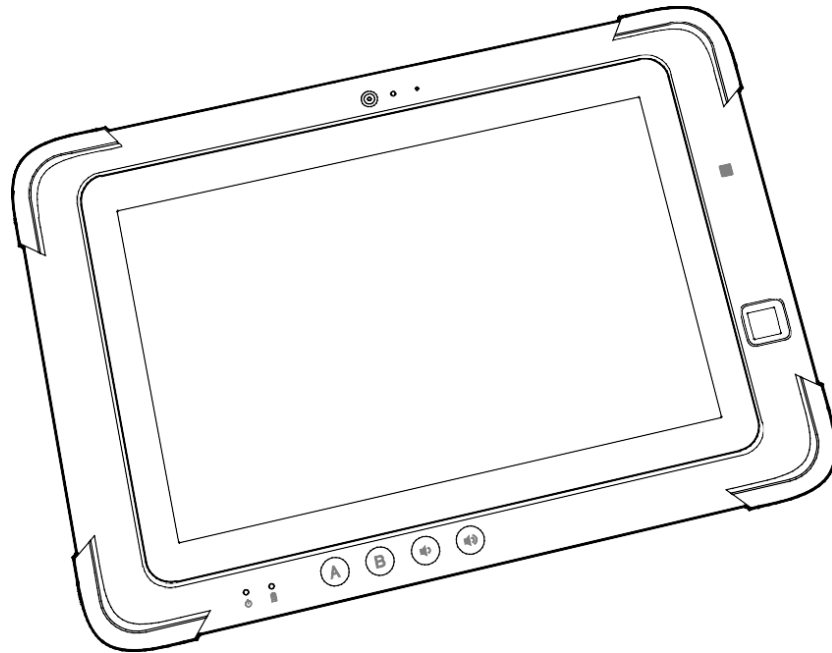

TABLE OF CONTENTS

Safety Precautions and Usage Notes	2
Regulatory Information	5
Directive 2014/53/EU	6
Your Tablet	9
Package Contents	9
Tablet Overview	10
Front View	10
Right View	11
Left View	12
Rear View	13
Top View	14
Bottom View	15
Getting Started	16
LED Indicators	16
Power Indicator	16
Battery Charge Status Indicator	17
Charging the Tablet	18
Powering On/Off the Tablet	18
Turning On/Off the Display	19
Operating Your Tablet	20
R232 Connection	20
SmartCard Reader (Optional)	21
NFC Sensor	22
Fingerprint Reader	23
Barcode Scanner (Optional)	24
Entering the BIOS Menu	25
Replacing the Battery	26
Battery Removal and Replacement	26
Specifications	28

Safety Precautions and Usage Notes

To reduce the risk of injury, loss of life, electric shock, fire, malfunction, and damage to equipment or property, always observe the following safety guidelines:

 **DANGER:**

Precautions on the Battery:

Failure to comply with the following precautions may result in electrolyte leakage, generation of heat, ignition or rupture.

- Avoid placing the battery in extreme heat (for example near fire or in direct sunlight). **DO NOT** throw the battery into a fire or expose it to excessive heat.
- When the battery has deteriorated, replace it with a new one.
- The battery is rechargeable and intended for the specified product. **DO NOT** use with any other products.
- Use only the specified battery with your tablet. Use of batteries other than those supplied by the manufacturer may present a safety hazard.

  **WARNING:**

If a malfunction or trouble occurs, immediately stop using the product, power off and unplug the AC adapter, and then remove the battery. Then contact technical support for repair.

  **WARNING:** Failure to comply with the following precautions may result in electric shock.

- **DO NOT** pull or insert the power adapter if your hands are wet.
- **DO NOT** connect the power adapter to a power source other than a 100-240 volts AC outlet. Connecting to a DC/AC converter (inverter) may damage the power adapter.
- Plug the power supply into an electrical outlet completely. **DO NOT** use a damaged plug or loose AC outlet.
- Hold the plug when unplugging the power supply.

 **WARNING:**

- **DO NOT** turn the volume up too loud when using headphones.
- **DO NOT** use this product with exposed in a hot or cold environment for a long period of time, low-temperature burns or frost-bite may result. When it is necessary to expose the skin to this product such as to scan a fingerprint, perform the operation in the shortest amount of time possible.

- DO NOT expose bare skin to this product when handling this unit in extreme hot or cold environments.



CAUTION:

- When using in a hot or cold environment, some peripherals and battery packs may fail to work properly. Check the operation environment of the peripherals before operating the product.
- Using this product continuously in a hot environment will shorten the product life. Avoid use in these types of environments.
- When using in low temperature environment, startup may become slow or battery operation time may become short. The tablet consumes power when the flash memory is warming up during startup. Therefore, if you are using battery power and the remaining power is low, the tablet may not start up.
- If you cannot power on the tablet, or the tablet does not resume from sleep. Leave it in an environment of 5°C or higher temperature for about an hour, and then power it on again.
- DO NOT use this product if connected with the AC adapter or any other cables connected during a thunderstorm.
- DO NOT place this product near any magnetic objects.



ESD WARNING:

Electrostatic discharge:

Electrostatic discharge is the sudden flow of electricity between two electrically charged objects caused by contact. The product may be damaged when it comes in contact with your hand or other objects with built-up static electricity.

Please take note of the following items to prevent damaging your product or losing important data:

- Please make sure the product is grounded properly when disconnecting the power source.
- Before installing a component, please place the component inside an anti-static container.
- Avoid touching the product's pins, leads, or electronic components.
- Please use non-magnetic tools when installing a component.
- Before handling a component, please touch a conductive metal surface to discharge the static electricity from your body.
- After removing a component, please store the component inside an anti-static container.

Camera Notes :

The camera's autofocus function may not perform as expected in the following circumstances.

- The subject is very dark.
- The subject lacks contrast (e.g. the sky, a white wall, etc.) or there is little contrast between the subject and the surroundings (e.g. the subject is standing in front of a white wall while wearing a white shirt).
- Objects of sharply differing brightness are included in the scene (e.g. the sun is behind the subject and the subject is in deep shadow).
- The subject is a flat object with only horizontal lines.
- The subject is a fast-moving object.
- The scene is poorly lit.
- The scene features bright reflections or backlighting.
- The scene features flickering objects (e.g. fluorescent lights).
- The scene features point light sources (e.g. light bulbs, spotlights, or LEDs).
- The scene features several objects that are different distances from the camera.

In these circumstances where the camera is unable to focus, point the camera at another object at the same distance as the camera as the subject, then wait for the camera to focus and take the picture.

Regulatory Information

**CAUTION:**

Do not operate this personal computer or handheld computer's incorporated wireless WAN modem in the presence of flammable gases or fumes. Switch off the cellular terminal when you are near petrol stations, fuel depots, chemical plants or where blasting operations are in progress. Operation of any electrical equipment in potentially explosive atmospheres can constitute a safety hazard.

**CAUTION:**

A risk of explosion from incorrect installation or misapplication of the battery or if the battery is replaced by an incorrect type may possibly occur. Dispose of used batteries according to the instructions.

CE Declaration of Conformity (EUROPE only)

The product has been marked with the CE Mark to illustrate its compliance.

The following countries comply with EU RED directive: Austria, Belgium, Bosnia-Herzegovina, Bulgaria, Croatia, Czech Republic, Cyprus, Denmark, Estonia, Finland, France, Germany, Greece, Hungary, Iceland, Ireland, Italy, Latvia, Liechtenstein, Lithuania, Luxemburg, Macedonia, Malta, Montenegro, Netherlands, Norway, Poland, Portugal, Romania, Slovakia, Slovenia, Spain, Sweden, Switzerland, United Kingdom.

The following list of territories complies with CE directive:

- France: French Polynesia, Guadeloupe, Martinique, Mayotte, Monaco, New Caledonia, Reunion, Saint Martin, Tahiti
- Italy: San Marino, Vatican
- Netherlands: Curacao, Bonaire, Saba, Saint Maarten, Saint Eustatius
- Spain: Andorra
- United Kingdom: Cayman Islands, Falklands Islands, Jersey, Gibraltar, Guernsey, Montserrat, Turk & Caicos, UK Virgin Islands

Directive 2014/53/EU

Technology	Frequency band [MHz]	Maximum transmit power [dBm] (less than)
WLAN 802.11b/g/n	2400-2483.5	20
WLAN 802.11a/n/ac	5150-5725	23
WLAN 802.11a/n/ac	5725-5875	13.98
Bluetooth BR/EDR/LE	2400-2483.5	10
NFC	13.56	-38.11
GPS	1575.42	TBC
GLONASS	1602MHz + n * 0.5625 MHz ("n" is a satellite's frequency channel number from -7 ~6)	TBC
WLAN & Bluetooth Combo Module	QCNFA425	
GPS	ubx-G7020	
NFC	TBC	

European Union conformity

EU contact: Techniczna 7, 92-518 Lodz, Poland

Compliance with the Radio Equipment Directive

Effective June 13, 2017, all products entering the EU that contain wireless radios now comply with the Radio Equipment Directive, 2014/53/EU. Disregard all current statements in other publications that relate to the R&TTE Directive, as they no longer apply to your product.

Hereby, Compal Electronics, INC., declares that the radio equipment types listed at the beginning of this document are in compliance with Directive 2014/53/EU.

The full text of the system EU declaration of conformity is available in next page.

This radio equipment operates with frequency bands and maximum radio-frequency power as listed at the beginning of this document.

Specific Absorption Rate (ICNIRP)

YOUR DEVICE MEETS INTERNATIONAL GUIDELINES FOR EXPOSURE TO RADIO WAVES.

Your device is a radio transmitter and receiver. It is designed not to exceed the limits for exposure to radio waves (radio frequency electromagnetic fields) recommended by international guidelines. The guidelines were developed by an independent scientific organization (ICNIRP) and include a substantial safety margin designed to assure the safety of all persons, regardless of age and health.

The radio wave exposure guidelines use a unit of measurement known as the Specific Absorption Rate, or SAR. The SAR limit for mobile devices is 2W/kg. Tests for SAR are conducted using standard operating positions with the device transmitting at its highest certified power level in all tested frequency bands. The highest SAR values under the ICNIRP guidelines for your device are listed at the end of this page.

During use, the actual SAR values for your device are usually well below the values stated. This is because, for purposes of system efficiency and to minimize interference on the network, the operating power of your mobile device is automatically decreased when full power is not needed for the data connection. The lower the power output of the device, the lower its SAR value. If you are interested in further reducing your RF exposure then you can easily do so by limiting your usage or simply keeping the device away from the body.

SAR is measured with the device at 0 mm to the body, while transmitting at the highest certified output power level in all frequency bands of the device. The maximum SAR value is 0.37 W/kg (head/body) averaged over 10 gram of tissue.

This equipment should be installed and operated with a minimum distance of 0 cm between the radiator and your body.

EU Frequency band restriction:

				
AT	BE	BG	CZ	DK
EE	FR	DE	IS	IE
IT	EL	ES	CY	LV
LI	LT	LU	HU	MT
NL	NO	PL	PT	RO
SI	SK	TR	FI	SE
CH	UK	HR		

NOTE: Products that can operate in the 5150MHz to 5350MHz are intended for indoor usage only.

Compal Electronics, Inc.

No. 581, Ruiguang Rd., Neihu District,
Taipei City 11492, Taiwan, R.O.C

Declaration of Conformity

We, **Compal Electronics, Inc.**,

Address: No. 581, Ruiguang Rd., Neihu District, Taipei City 11492, Taiwan, R.O.C.
declare under our sole responsibility that the below mentioned radio equipment type is in compliance with [Directive 2014/53/EU](#).

Model Name: CXXXXX-CAXA0-XXXXXX-XXXX (X:0~9,A~Z)

Intended use: Rugged Tablet

Software Version: Win 10

NB company name: TUV

NB company number:

Certification number:

The full text of the complied standards are as below listed:

1. Health (Article 3.1(a) of [Directive 2014/53/EU](#))

Applied Standard(s):

- EN 50566: 2013 / AC:2014
- EN 62209-2:2010
- EN 62479:2010

2. Safety (Article 3.1(a) of [Directive 2014/53/EU](#))

Applied Standard(s):

- EN 60950-1:2006+A11:2009+A1:2010+A2:2013

3. Electromagnetic compatibility (Article 3.1 (b) of [Directive 2014/53/EU](#))

Applied Standard(s):

- EN 301 489-1 V2.1.1/-17 V3.1.1

4. Radio frequency spectrum usage (Article 3.2 of [Directive 2014/53/EU](#))

Applied Standard(s):

- EN 300 328 V2.1.1
- Draft EN 301 893 V2.1.0
- EN 300 330 V2.1.1
- EN 303 413 V1.1.0

Win Chen / Common Engineering Director

Compal Electronics, INC.

Tel.: +886 2 8797 8588

E-mail: win_chen@compal.com

Your Tablet

Package Contents

Ensure that all of the proper items are included with the tablet in the packaging. The items that should be included in the packaging are:

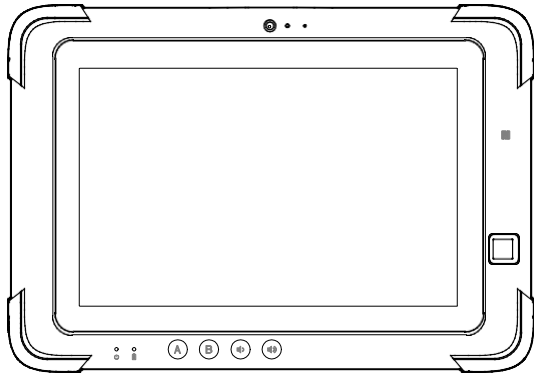

Tablet

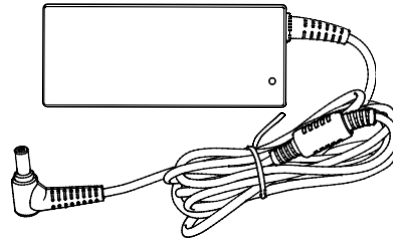

Power Adapter

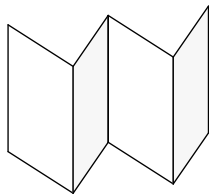

Quick Start Guide

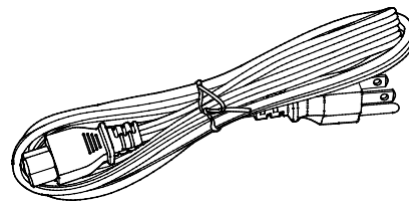

Power Cord

Tablet Overview

Front View

The following illustration shows the front side of the system.

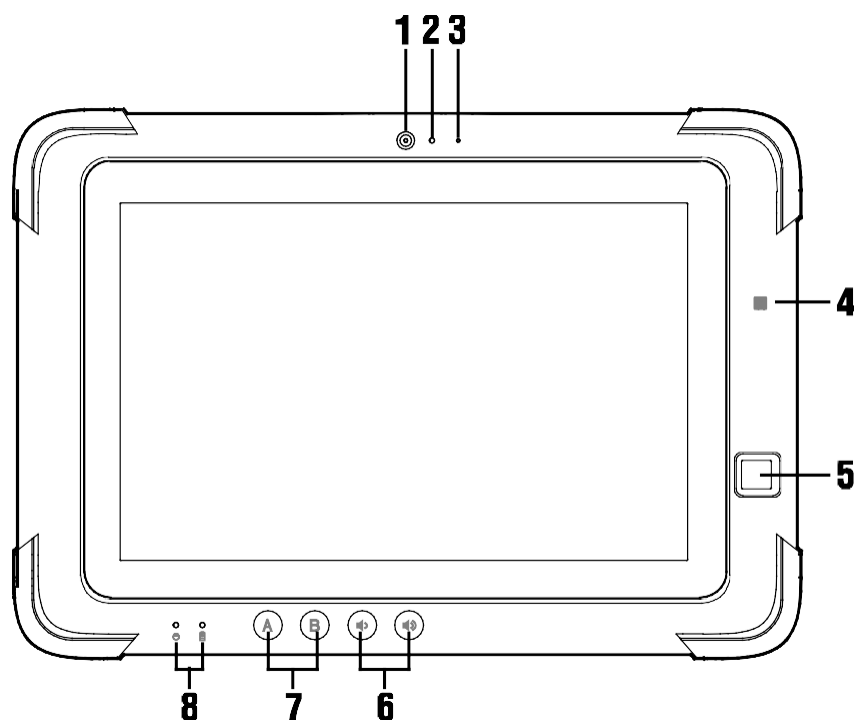

Number	Component	
1	Front-Facing Camera (2MP)	Captures images and videos.
2	Ambient Light Sensor	Senses the ambient light in order to make adjustments to the brightness of the display.
3	Microphone	Captures audio.
4	NFC Sensor	Reads NFC devices/contactless smart cards.
5	Fingerprint Reader	Scans the user's fingerprint.
6	Volume Down/Up Button	Decreases / Increases the volume.
7	Hotkey A/B	Customizable hotkeys. NOTE: The Quick Launch Setting app designed for configuring the hotkeys may not be initially installed by the manufacturer and may need to be installed by the user on a system running the Windows OS only.
8	Status LEDs	Displays system status including power, and battery/charging status. For more information on LED behavior, see LED Indicators .

Right View

The following illustration shows the right side of the system.

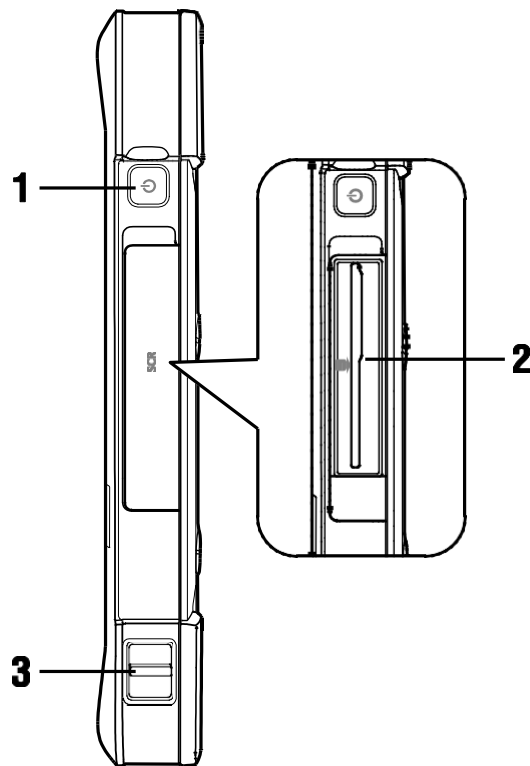

Number	Component
1	Power Button Turns the tablet or display on/off.
2	SmartCard Reader (Optional) Reads SmartCards.
3	Strap Loop Used to attach a carrying strap to the tablet. <i>NOTE: A carrying strap is not provided by the manufacturer and must be purchased separately by the user.</i>

Left View

The following illustration shows the left side of the system.

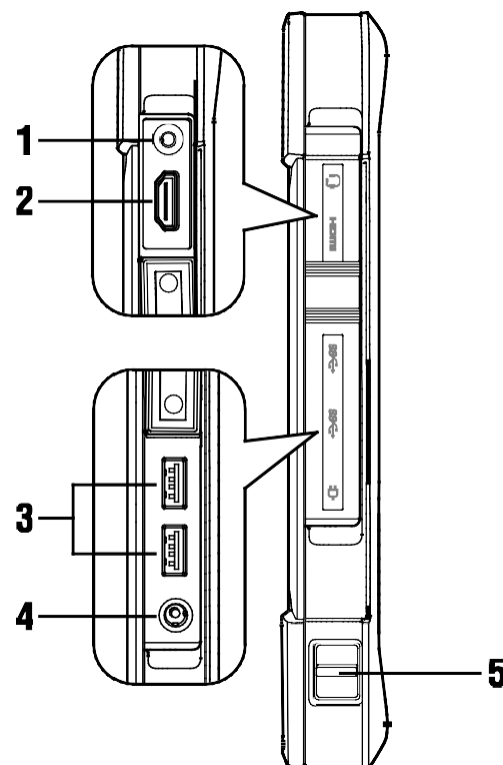

Number	Component	Description
1	Universal Audio Jack	Connects to headphones, speakers, microphones and other audio output/input devices.
2	HDMI Port	Connects to video devices such as a display, television, or projector.
3	USB 3.0 Ports	Connects to USB devices.
4	DC-In Port	Connects to the adapter for charging.
5	Strap Loop	Used to attach a carrying strap to the tablet. <i>NOTE: A carrying strap is not provided by the manufacturer and must be purchased separately by the user.</i>

Rear View

The following illustration shows the rear side of the system.

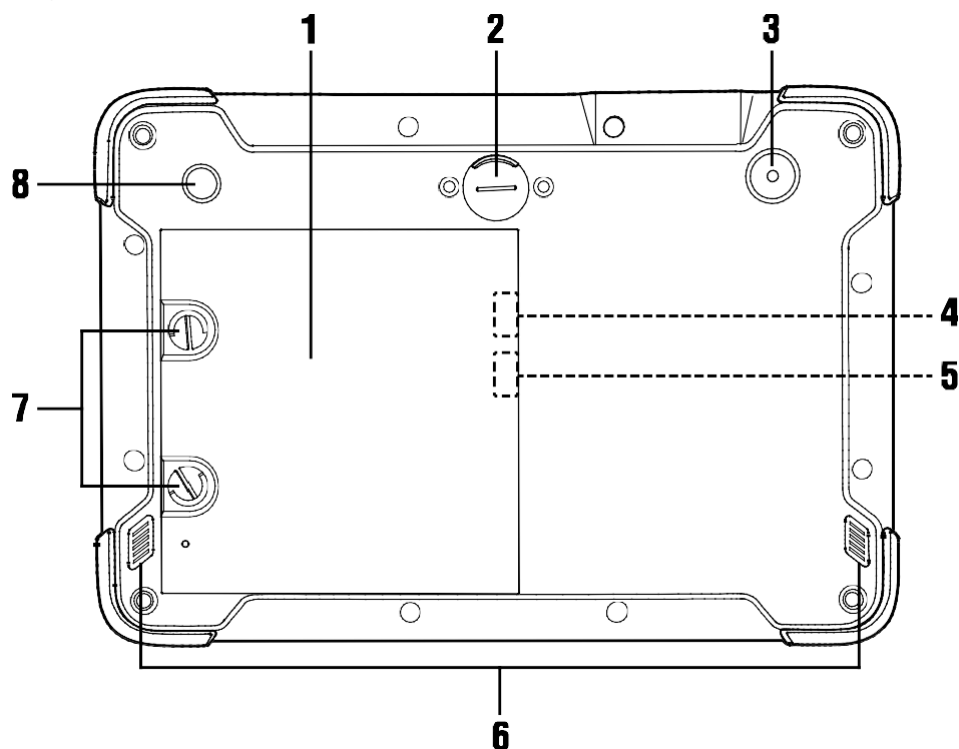

Number	Component	Component
1	Battery Compartment Cover	Covers the removable battery, optional SIM card, and SD card slots.
2	Hand-Holder Slot	Used to attach an optional holder to conveniently carry the tablet using a single hand.
3	Rear-Facing Camera (8MP)	Captures images and videos.
4	SIM Card Slot (Optional) <i>Located inside the battery compartment</i>	Accepts a Micro-SIM card for 4G LTE mobile broadband. NOTE: The SIM card slot is only accessible after removing the main battery, for information on removing the battery see Battery Removal and Replacement .
5	SD Card Slot <i>Located inside the battery compartment</i>	Accepts microSD card for data storage. NOTE: The SD card slot is only accessible after removing the main battery, for information on removing the battery see Battery Removal and Replacement .
6	Speakers (1W)	Broadcasts audio played by the tablet.
7	Battery Compartment Locks	Secures the battery compartment cover to the tablet, turn counter-clockwise to unlock the battery compartment cover.
8	Barcode Scanner Button	Activates the optional barcode scanner (the button is non-functional for models without a barcode scanner).

Top View

The following illustration shows the top side of the system.

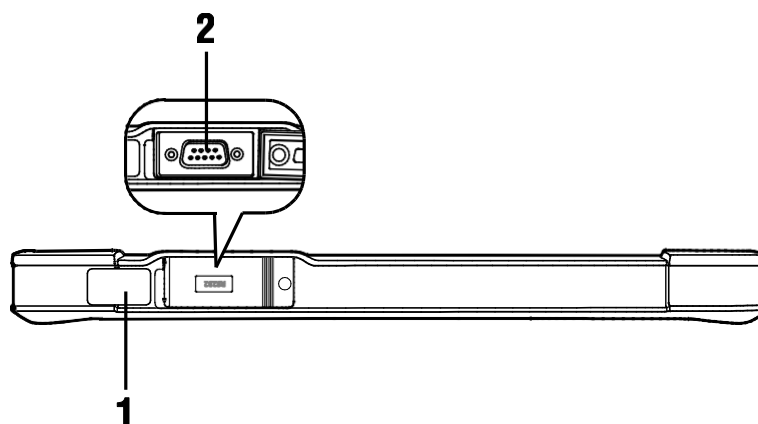

Number		Component
1	Barcode Scanner (Optional)	Scans barcodes/QR codes.
2	RS-232 Port	Receives and transmits data from/to other computers or data devices.

Bottom View

The following illustration shows the bottom side of the system.

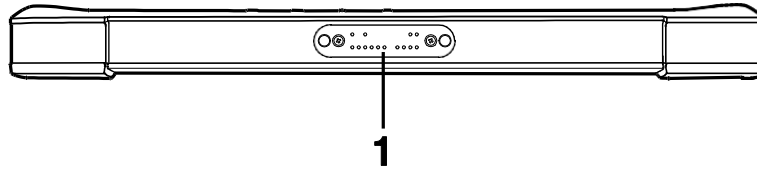

Number	Component	
1	Docking Connector	Connects to the optional tablet dock.

Getting Started

LED Indicators

The system status LEDs are located on the front of the system, they include LEDs for the following: power, and battery charging status.

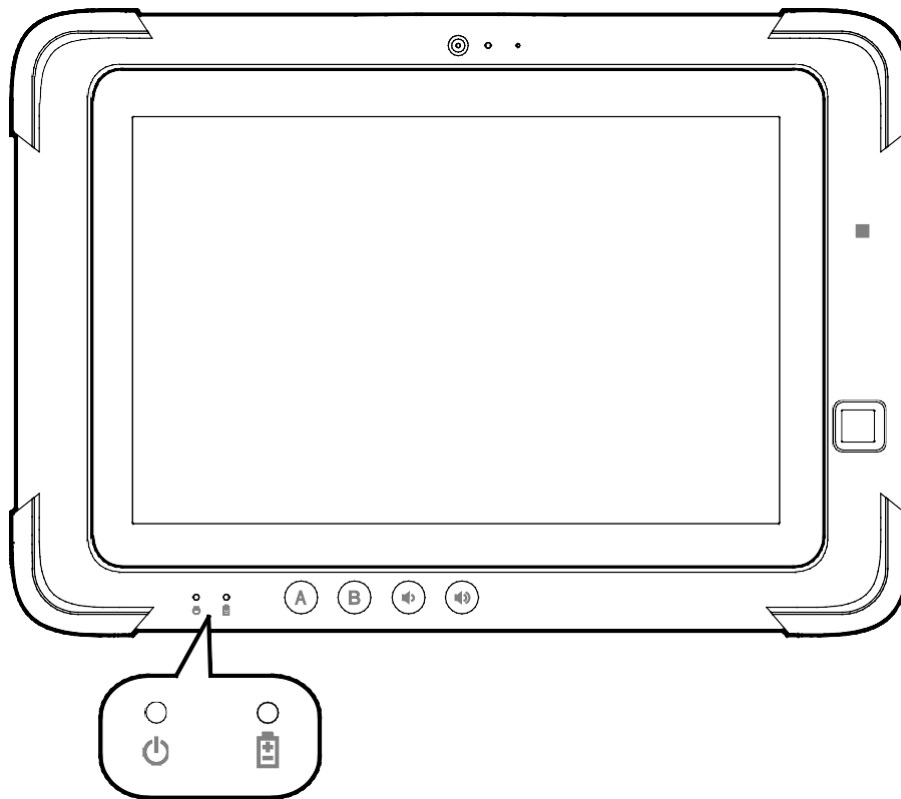

Power Indicator

LED icon	LED Behavior	Description
	Solid Blue	The power is on.
	Off	The system is in Sleep mode or is powered off.

Battery Charge Status Indicator

When the tablet is equipped with a primary battery (main battery) and a secondary battery (bridge battery):

LED icon	LED Behavior	Description
	Solid Green	Both batteries are fully charged.
	Solid Amber	Either one of the batteries is charging.
	Off	The system is running on primary or secondary battery power. <i>NOTE: If the battery indicator is not lit even when the adapter is properly connected and the batteries are properly installed, the adapter's protection function may be activated. In this circumstance disconnect the adapter and wait for 1 minute before reconnecting the adapter.</i>
	Blinking Red	<ul style="list-style-type: none"> The primary battery level is critically low (the capacity is below 10%). This behavior will occur regardless of whether the secondary battery level is at full charge capacity or not. The battery compartment cover is not closed properly.

Charging the Tablet

1. Connect the power cord to the power adapter.
2. Connect the power adapter to the DC-In port of the tablet.
3. Plug the power supply into an electrical outlet. The battery charge LED lights amber when your tablet is getting charged.

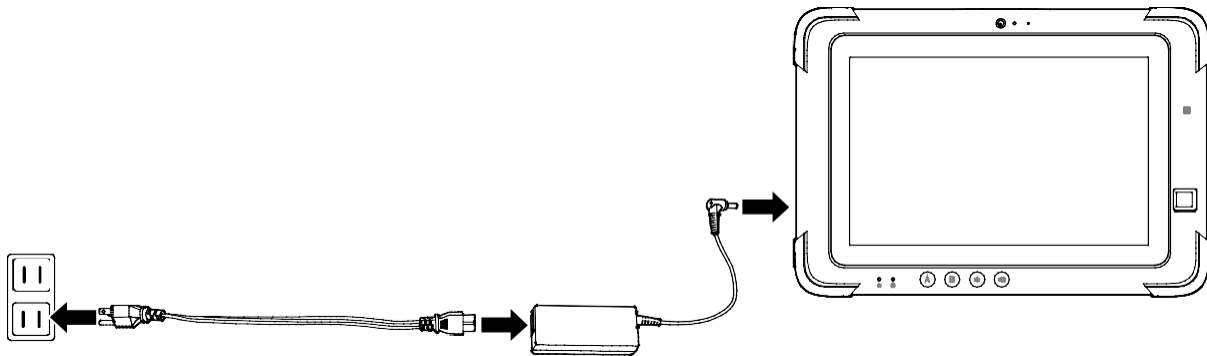

NOTE: The battery is not fully charged when you unpack your tablet. It is recommended to keep the power supply plugged in for at least 5 hours until the battery is fully charged.

Powering On/Off the Tablet

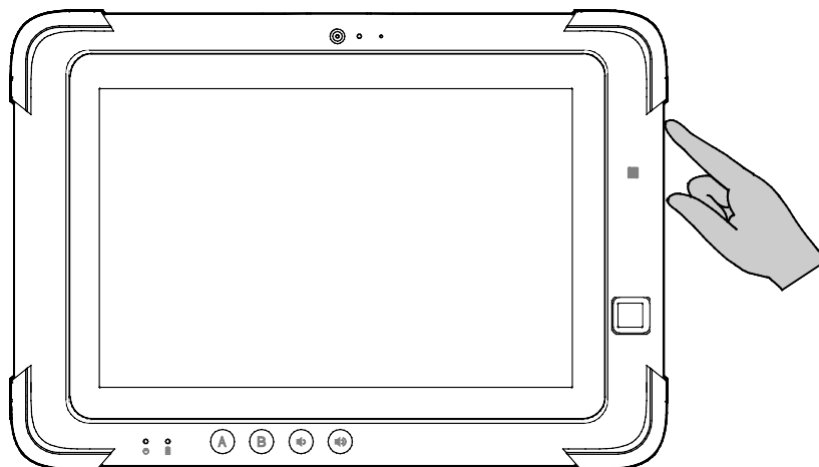

To power on the tablet, press the power button. When the system starts, the power LED will light up.

To hard power-off the tablet, press and hold the power button for at least 5 seconds.

NOTE: The tablet can be powered off directly through the operating system for certain systems.

Turning On/Off the Display

Press the power button when the system is on to turn off the display and put the system in standby mode.

When the system is in standby mode, press the power button once to wake up the system and turn the display on.

Operating Your Tablet

R232 Connection

The RS-232 port located on the top of the tablet is an interface that allows for the transmission of data to and from the tablet and other data devices (such as a computer or infrastructure-related equipment) for various purposes including the transfer of information or sending commands.

Connections to the RS-232 port require a RS-232 cable as shown in the image below.

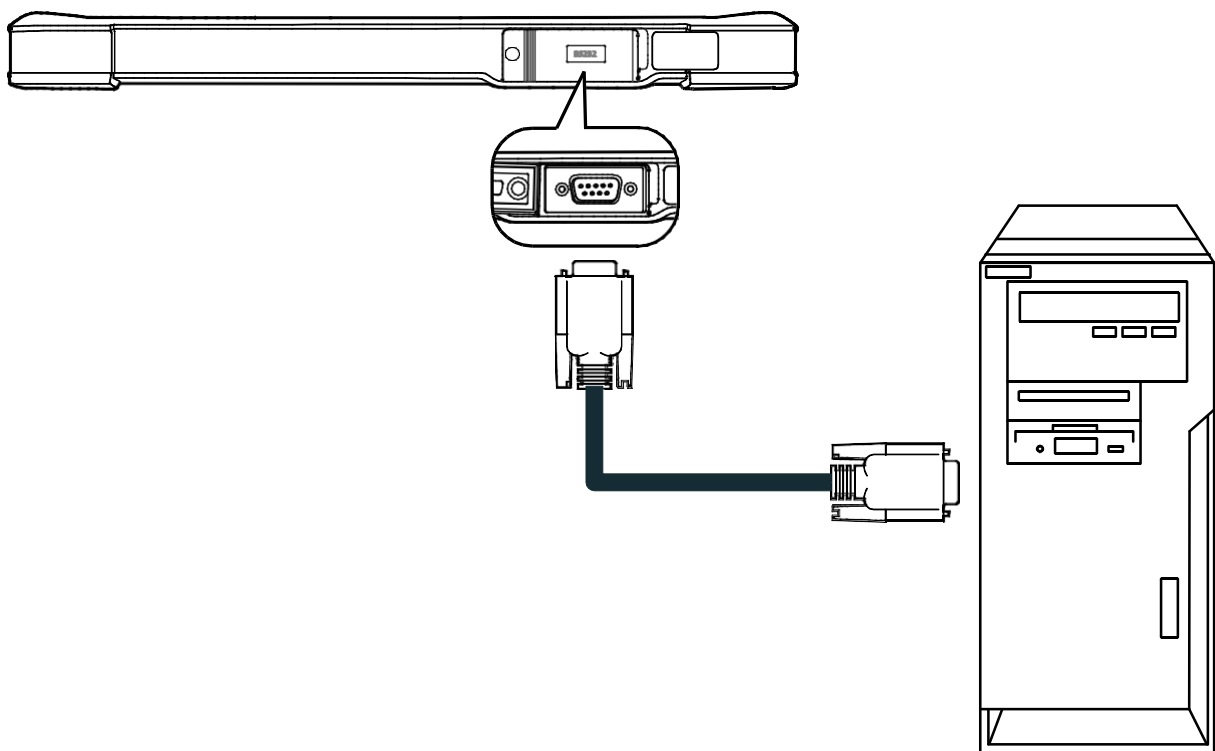

SmartCard Reader (Optional)

The optional SmartCard reader located on the right side of the tablet allows for the transmission of data, mainly for identification/authentication purposes, to and from the tablet and a smart card.

Insert a smart card into the reader to read/process/write information from/to the smart card. Ensure that the smart card is inserted into the card slot securely in the correct orientation with the chip facing down, as shown in the image below.

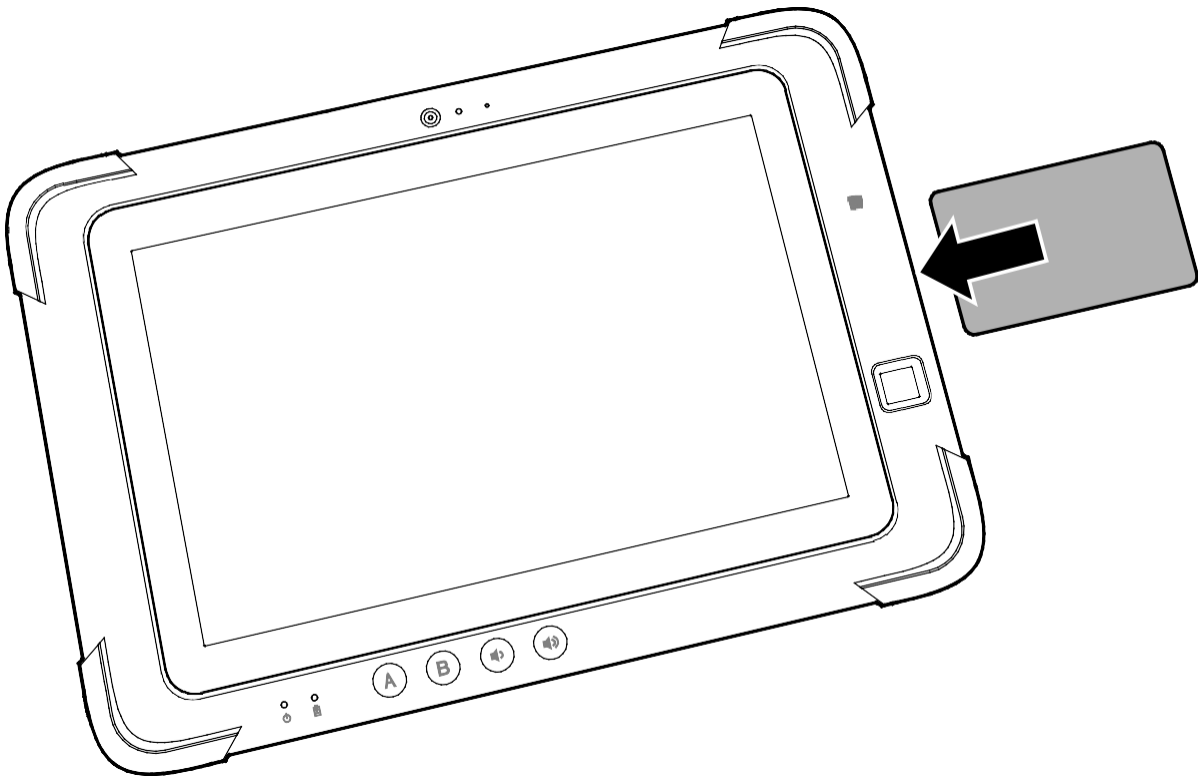

NOTE: Additional SmartCard application/software is required for this feature.

NOTE: The application/software is not provided by the manufacturer and must be installed separately by the user.

NFC Sensor

The NFC sensor located on the front of the tablet allows it to interact with other NFC-enabled devices or NFC cards/tags, such as smartphones or contactless smart cards.

Tap an NFC-supported device or card/tag to the NFC logo, indicating the sensor area, to activate the NFC sensor, as shown in the image below.

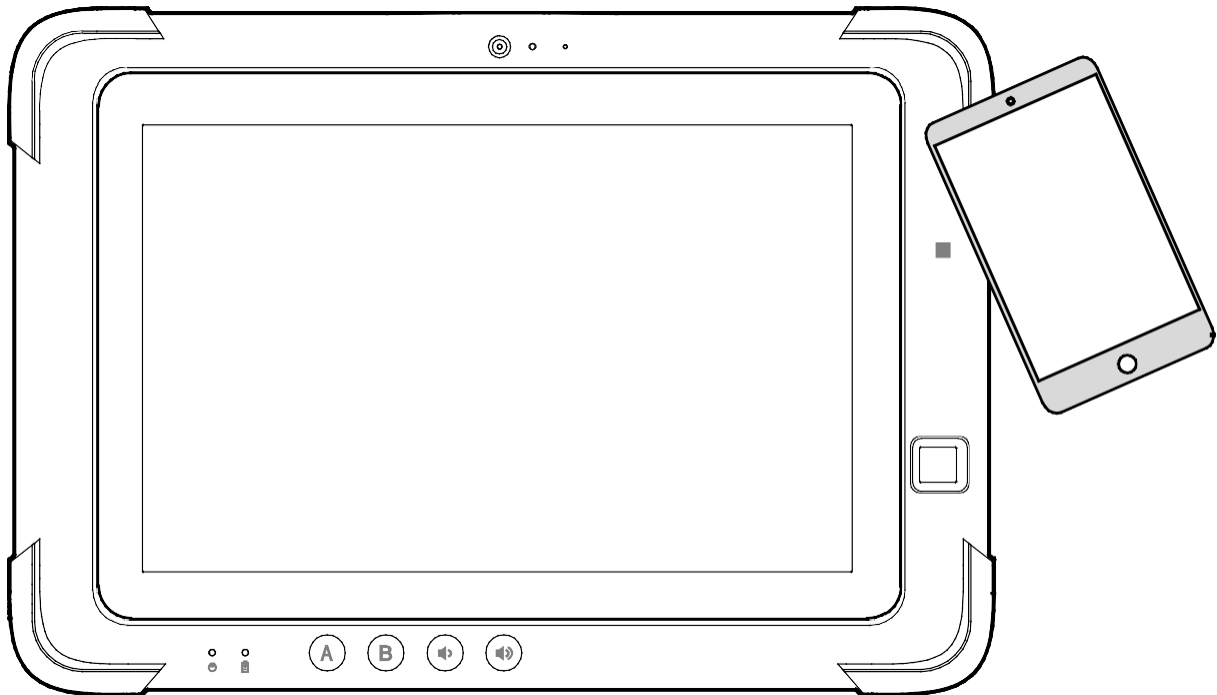

NOTE: Additional NFC reader application/software is required for this feature.

NOTE: The application/software is not provided by the manufacturer and must be installed separately by the user.

Fingerprint Reader

The fingerprint reader located on the front of the tablet allows for a quick, convenient and more secure way to log into the system by scanning your fingerprint instead of entering a password.

Place your finger on the fingerprint sensor until your fingerprint has been scanned to activate the reader (removing your finger too fast or not pressing your finger completely on the scanner may make a scan unsuccessful), as shown in the image below.

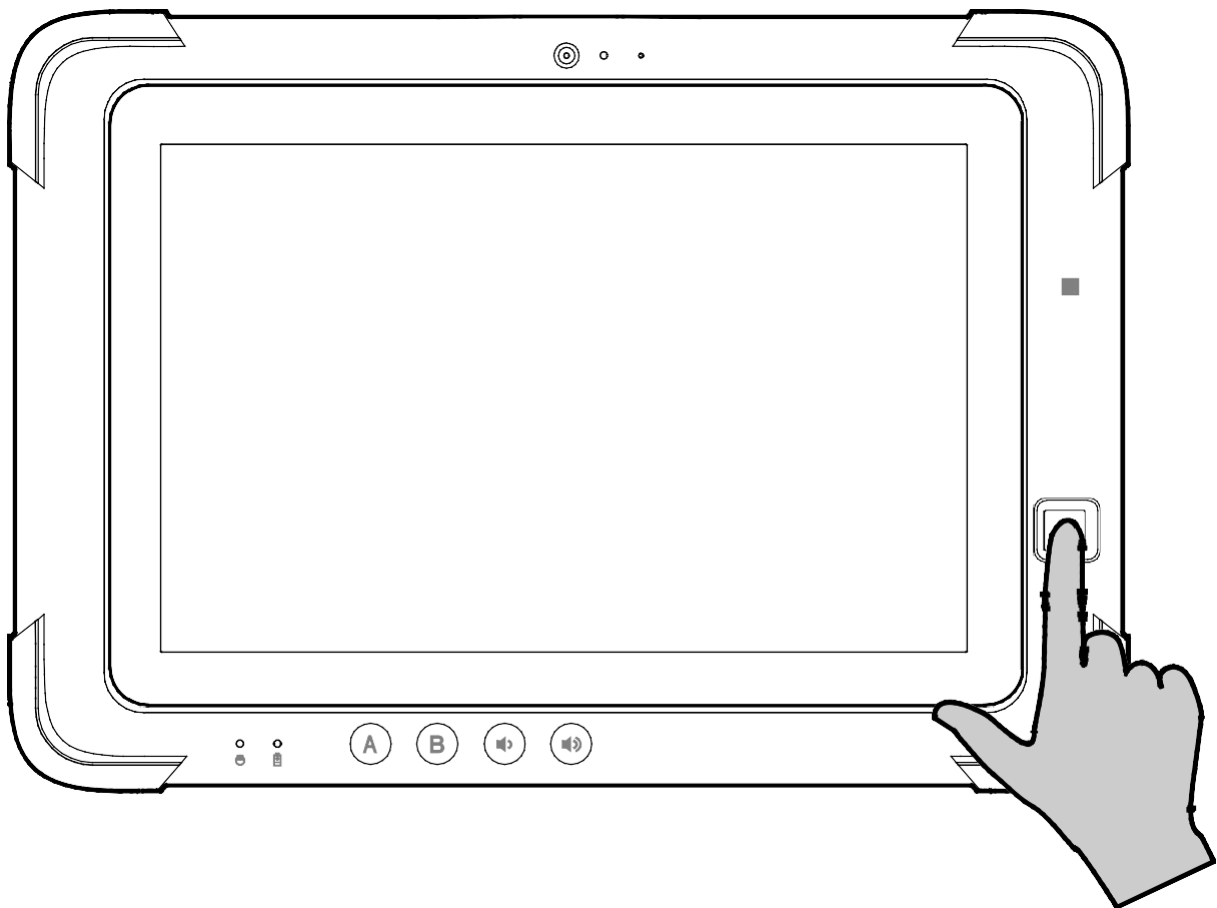

NOTE: Additional fingerprint security application/software is required for this feature.

Barcode Scanner (Optional)

The optional barcode scanner located on the top of the tablet allows the tablet to retrieve information from bar codes when the barcode scanner button is pressed.

1. Open the application/software that you want to use to read the barcode data.

NOTE: The application/software is not provided by the manufacturer and must be installed separately by the user.

2. Place the scanner lens directly over the barcode at an appropriate distance.
3. Press the barcode scanner button located on the back of the tablet. Ensure that the aiming range covers the entire barcode area.

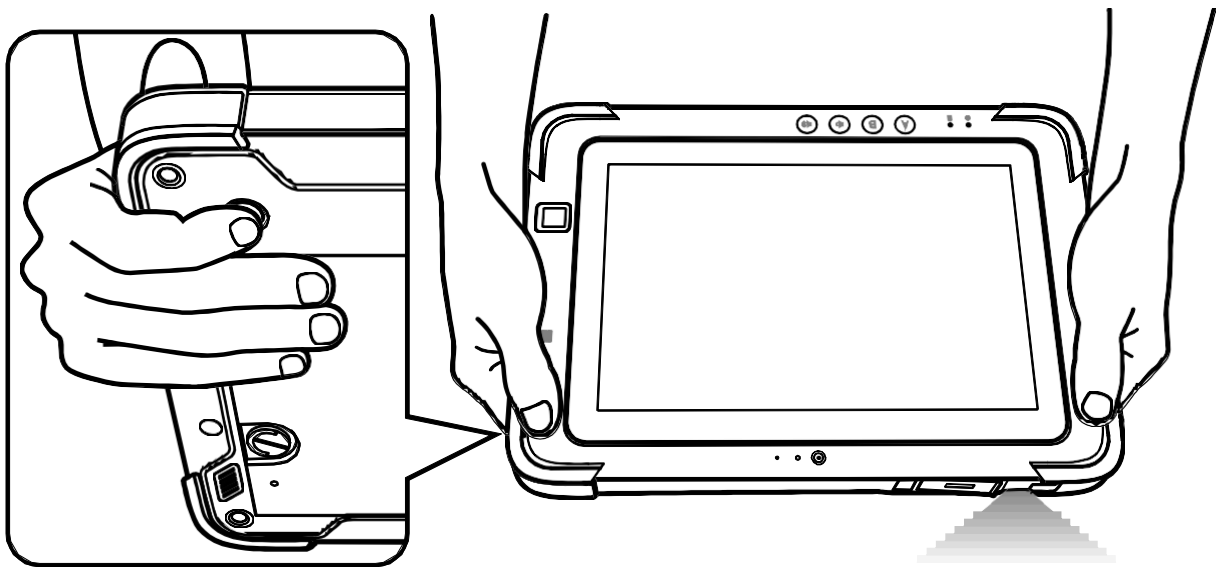

The data will appear in the application/software with a beep when the barcode is successfully scanned.

NOTE: Different types of barcodes may require specific barcode scanning applications.

Entering the BIOS Menu

BIOS (Basic Input/Output System) is a hardware configuration program installed in the tablet and initialized when the tablet is powered on. The BIOS is preset to optimal default settings for normal use, but in certain cases a user or technician might want to access the BIOS menu to change certain hardware settings for the tablet or to boot directly to a specific bootable device. In order to enter the tablet's BIOS menu follow the instructions below:

1. Press the power button to power on the tablet.
2. Immediately press and hold the volume up button until a BIOS menu appears.

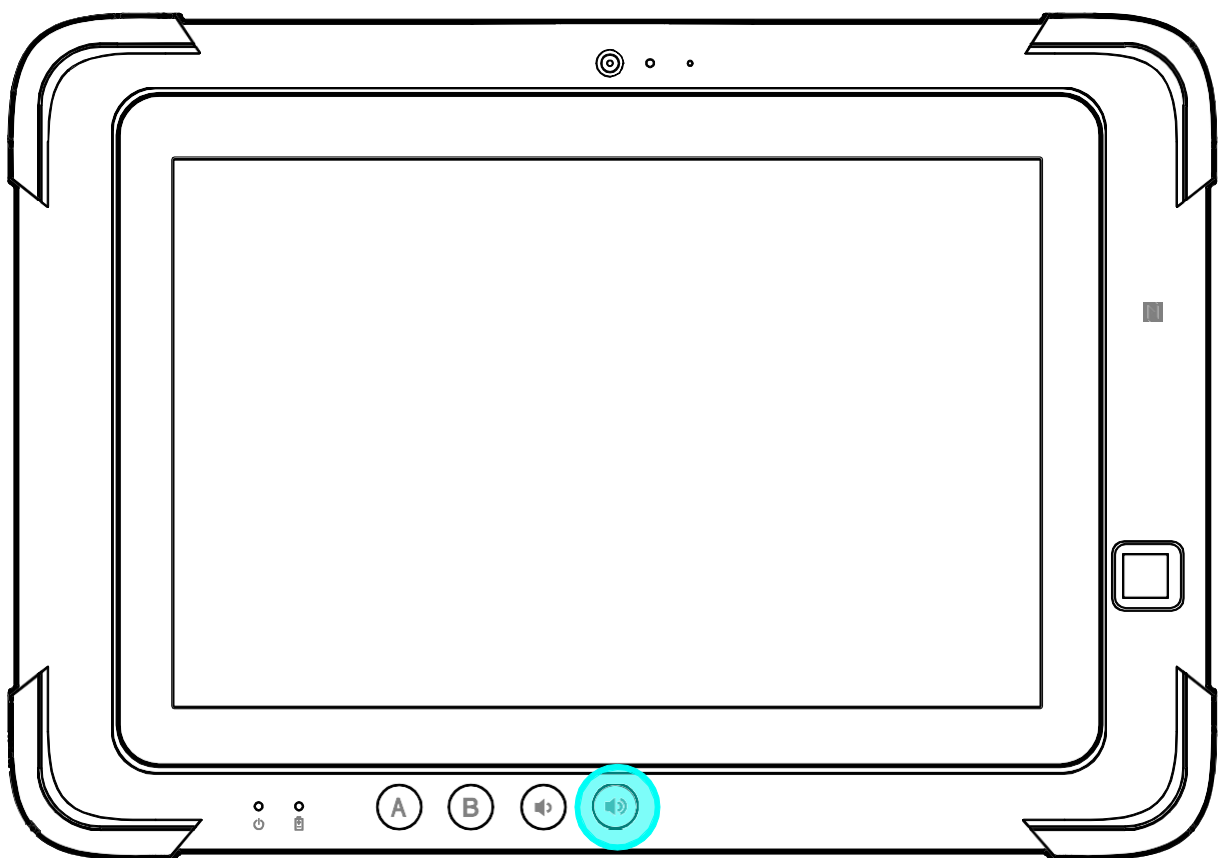

Replacing the Battery

Battery Removal and Replacement

The primary battery is a 7.2V/3950mAh battery installed on all models under the battery compartment cover located on the rear of the tablet, which can be removed and replaced by the user.

The secondary battery, also called a bridge battery, is located internally and cannot be accessed by the user. The secondary battery is mainly used to power the tablet when the primary battery is removed.

The primary battery becomes a hot-swappable component, meaning that replacement of the battery can occur while the machine is still powered on without harm to the system.

In order to access the primary battery for removal/replacement follow the instructions below:

NOTE: When replacing the main battery in models featuring a bridge battery, ensure that the bridge battery is at least at 40% capacity.

1. Place the tablet on a flat surface with the rear side up.
2. Turn the two battery compartment locks counter-clockwise to unlock the battery compartment cover.
3. Remove the battery compartment cover.

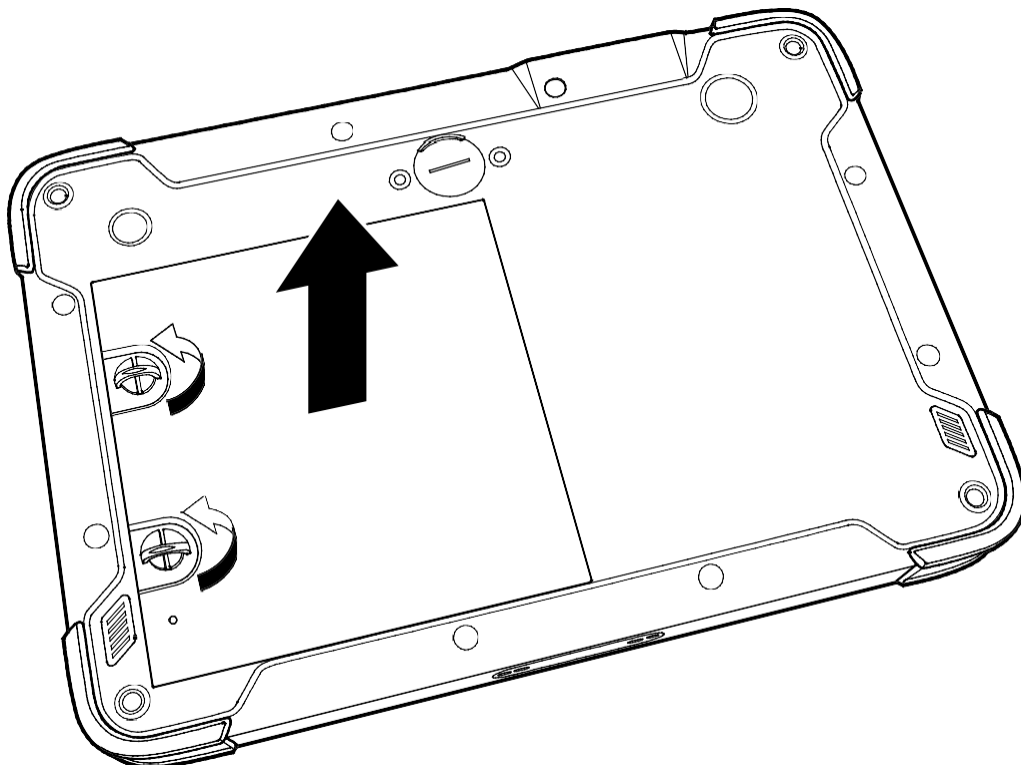

4. Use the tab to pull and remove the battery from the battery compartment.

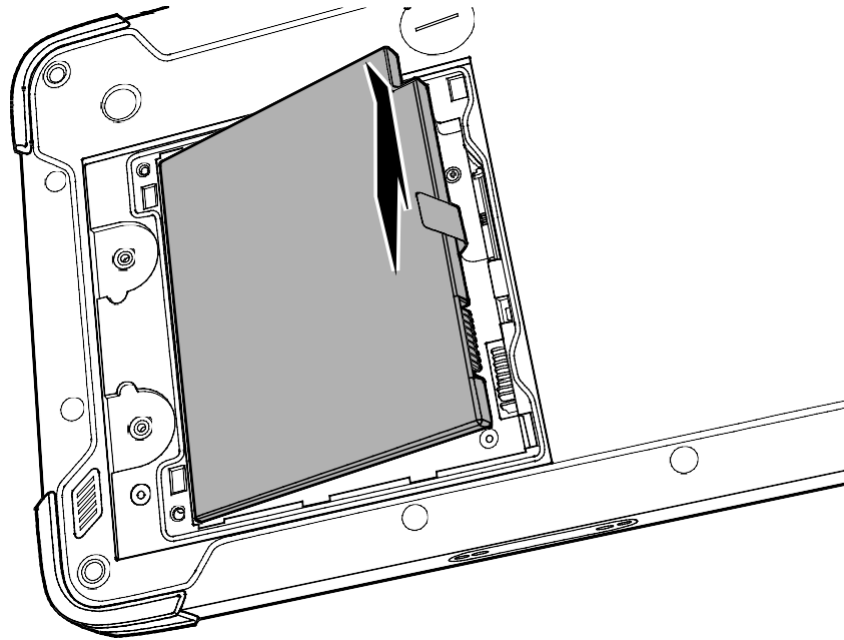

5. To insert/replace the battery reverse the steps described above

NOTE: Dispose of used batteries according to the local laws and regulations of your region.

Specifications

CPU	Intel® Celeron® Processor N3350
Memory*	4GB / 8GB on-board LPDDR4
Storage*¹	128GB / 256GB M.2 SSD (Type 2242)
Display	10.1" 1280 x 800 (HD) pixels, 500 nits
Pointing Device	<ul style="list-style-type: none"> • Gorilla® Glass III touchscreen, supports 10 finger touch, and touch for PVC/latex gloves • Active Stylus (Capacitive type) support² (The Stylus is sold separately and is not shipped with the tablet.)
Communication	<ul style="list-style-type: none"> • WLAN – 802.11a/b/g/n/ac + Bluetooth v4.1 (LGA module) • NFC – ISO/IEC 14443 A/B, ISO/IEC 15693/18092, NFCIP-1, NFCIP-2, Support MIFARE and Felica • GPS L1 (standalone) • [Manufacturing Option] 4G LTE embedded GPS (data mode only)
Audio	<ul style="list-style-type: none"> • Stereo Box type 1W • Individual microphone
Camera	<ul style="list-style-type: none"> • 2M (1600 x 1200) front-facing camera, 30 fps (video), fixed focus • 8M (3264 x 2448) rear-facing camera, 10 fps (video), auto focus
Sensor	<ul style="list-style-type: none"> • Ambient light sensor • Gravity sensor • Gyro sensor • Digital compass • [Optional] Proximity sensor
Reader	<ul style="list-style-type: none"> • [Optional] Barcode reader (BCR), 1D/2D support • [Optional] SmartCard reader (SCR)
Media Card Slot	<ul style="list-style-type: none"> • [Optional] Micro-SIM card (inside the battery compartment) • microSD card³ (inside the battery compartment)
IO Ports and Connectors	<ul style="list-style-type: none"> • Universal audio Jack • USB 3.0 ports⁴*2 • HDMI port⁵ • Pogopin (for docking connector)⁶ • RS-232 port (D-type)⁷
Buttons	<ul style="list-style-type: none"> • Power button • Quick launch buttons*2 • Volume buttons*2 • Barcode scanner button (BCR trigger)
Security	<ul style="list-style-type: none"> • Firmware Trusted Platform Module 2.0 • Fingerprint scanning
Adapter	<ul style="list-style-type: none"> • Input: AC100V–240V, 50Hz/60Hz • Output: DC 19V, 3.42A

Battery	<ul style="list-style-type: none"> • Removable main battery – Li-ion, 28.44Wh, 7.2V, 3950mAh • Embedded bridge battery – Li-ion, 2.701Wh, 7.4V, 365mAh (for supporting hot-swapping)
Operating Time⁸	Approximately 8 hours for a fully charged main battery
Dimensions (W x D x H)	297.6mm x 206.5mm x 25.0mm (11.7 inches x 8.13 inches x 0.98 inches)
Weight	1230g (2.71lbs.)
Note	<p>* The specifications listed in this field denote options which the user can select for their tablet.</p> <p>¹ The storage reported by your operating system or certain applications may be reported at a lower amount.</p> <p>² Operation has been tested and confirmed using EETI ESS-025-160315-1. Operation of other styluses is not guaranteed.</p> <p>³ The microSD slot does not guarantee compatibility with all microSD cards.</p> <p>⁴ The USB 3.0 ports do not guarantee compatibility with all USB-compatible peripherals.</p> <p>⁵ The HDMI port does not guarantee compatibility with all HDMI-compatible peripherals.</p> <p>⁶ Only for use with the CAXA0 dock.</p> <p>⁷ The RS232 port does not guarantee compatibility with all RS232-compatible peripherals.</p> <p>⁸ Battery performance features such as charge time and life span can vary according to the condition under which the computer and battery are used. Battery operation and recharge times will vary based on many factors, including screen brightness, applications, features, power management, battery conditioning and other customer preferences. Battery testing results from MobileMark 2014.</p>

FCC:

Federal Communication Commission Interference Statement

This device complies with Part 15 of the FCC Rules. Operation is subject to the following two conditions: (1) This device may not cause harmful interference, and (2) this device must accept any interference received, including interference that may cause undesired operation.

This equipment has been tested and found to comply with the limits for a Class B digital device, pursuant to Part 15 of the FCC Rules. These limits are designed to provide reasonable protection against harmful interference in a residential installation. This equipment generates, uses and can radiate radio frequency energy and, if not installed and used in accordance with the instructions, may cause harmful interference to radio communications. However, there is no guarantee that interference will not occur in a particular installation. If this equipment does cause harmful interference to radio or television reception, which can be determined by turning the equipment off and on, the user is encouraged to try to correct the interference by one of the following measures:

- Reorient or relocate the receiving antenna.
- Increase the separation between the equipment and receiver.
- Connect the equipment into an outlet on a circuit different from that to which the receiver is connected.
- Consult the dealer or an experienced radio/TV technician for help.

FCC Caution:

- Any changes or modifications not expressly approved by the party responsible for compliance could void the user's authority to operate this equipment.
- This transmitter must not be co-located or operating in conjunction with any other antenna or transmitter.

Radiation Exposure Statement:

This device meets the government's requirements for exposure to radio waves. This device is designed and manufactured not to exceed the emission limits for exposure to radio frequency (RF) energy set by the Federal Communications Commission of the U.S. Government.

The exposure standard for wireless device employs a unit of measurement known as

the Specific Absorption Rate, or SAR. The SAR limit set by the FCC is 1.6W/kg. * Tests for SAR are conducted using standard operating positions accepted by the FCC with the device transmitting at its highest certified power level in all tested frequency bands.

Note: The country code selection is for non-US model only and is not available to all US model. Per FCC regulation, all WiFi product marketed in US must fixed to US operation channels only.

IC:

- ❶ This device complies with Industry Canada license-exempt RSS standard(s). Operation is subject to the following two conditions:
 - 1) this device may not cause interference, and
 - 2) this device must accept any interference, including interference that may cause undesired operation of the device.
- ❶ Le présent appareil est conforme aux CNR d'Industrie Canada applicables aux appareils radio exempts de licence. L'exploitation est autorisée aux deux conditions suivantes:
 - 1) l'appareil ne doit pas produire de brouillage, et
 - 2) l'utilisateur de l'appareil doit accepter tout brouillage radioélectrique subi, même si le brouillage est susceptible d'en compromettre le fonctionnement.
- ❷ This Class B digital apparatus complies with Canadian ICES-003.
- ❷ Cet appareil numérique de la classe B est conforme à la norme NMB-003 du Canada.
- ❹ This device and its antenna(s) must not be co-located or operating in conjunction with any other antenna or transmitter, except tested built-in radios.
- ❹ Cet appareil et son antenne ne doivent pas être situés ou fonctionner en conjonction avec une autre antenne ou un autre émetteur, exception faites des radios intégrées qui ont été testées.
- ❺ The County Code Selection feature is disabled for products marketed in the US/ Canada.

- ⑤ La fonction de sélection de l'indicatif du pays est désactivée pour les produits commercialisés aux États-Unis et au Canada.

Radiation Exposure Statement:

The product comply with the Canada portable RF exposure limit set forth for an uncontrolled environment and are safe for intended operation as described in this manual. The further RF exposure reduction can be achieved if the product can be kept as far as possible from the user body or set the device to lower output power if such function is available.

Déclaration d'exposition aux radiations:

Le produit est conforme aux limites d'exposition pour les appareils portables RF pour les Etats-Unis et le Canada établies pour un environnement non contrôlé.

Le produit est sûr pour un fonctionnement tel que décrit dans ce manuel. La réduction aux expositions RF peut être augmentée si l'appareil peut être conservé aussi loin que possible du corps de l'utilisateur ou que le dispositif est réglé sur la puissance de sortie la plus faible si une telle fonction est disponible.

Caution :

- 1) the device for operation in the band 5150-5250 MHz is only for indoor use to reduce the potential for harmful interference to co-channel mobile satellite systems;
- 2) the maximum antenna gain permitted for devices in the bands 5250-5350 MHz and 5470-5725 MHz shall comply with the e.i.r.p. limit; and
- 3) the maximum antenna gain permitted for devices in the band 5725-5825 MHz shall comply with the e.i.r.p. limits specified for point-to-point and non point-to-point operation as appropriate.
- 4) the worst-case tilt angle(s) necessary to remain compliant with the e.i.r.p. elevation mask requirement set forth in Section 6.2.2(3) shall be clearly indicated.
- 5) Users should also be advised that high-power radars are allocated as primary users (i.e. priority users) of the bands 5250-5350 MHz and 5650-5850 MHz and that these radars could cause interference and/or damage to LE-LAN devices.

Avertissement:

- 1) les dispositifs fonctionnant dans la bande 5150-5250 MHz sont réservés uniquement pour une utilisation à l'intérieur afin de réduire les risques de brouillage préjudiciable aux systèmes de satellites mobiles utilisant les mêmes

canaux;

- 2) le gain maximal d'antenne permis pour les dispositifs utilisant les bandes 5250-5350 MHz et 5470-5725 MHz doit se conformer à la limite de p.i.r.e.;
- 3) le gain maximal d'antenne permis (pour les dispositifs utilisant la bande 5725-5825 MHz) doit se conformer à la limite de p.i.r.e. spécifiée pour l'exploitation point à point et non point à point, selon le cas.
- 4) les pires angles d'inclinaison nécessaires pour rester conforme à l'exigence de la p.i.r.e. applicable au masque d'élévation, et énoncée à la section 6.2.2 3), doivent être clairement indiqués.
- 5) De plus, les utilisateurs devraient aussi être avisés que les utilisateurs de radars de haute puissance sont désignés utilisateurs principaux (c.-à-d., qu'ils ont la priorité) pour les bandes 5250-5350 MHz et 5650-5850 MHz et que ces radars pourraient causer du brouillage et/ou des dommages aux dispositifs LAN-EL.