



FCC/IC Test Report

FOR

u-blox AG

Model Name: LISA-U200

Marketing Name: LISA-U200

Description: GSM/WCDMA/HSPA Data and Voice Module

FCC ID: XPYLISAU200

IC ID: 8595A-LISAU200

47 CFR Part 2, 27

RSS-139 Issue 2

TEST REPORT #: EMC_CETEC_046_12001_WWAN_Rev2

DATE: 2012-10-24



**FCC listed:
A2LA Accredited**

**IC recognized #
3462B-1**

CETECOM Inc.

411 Dixon Landing Road ♦ Milpitas, CA 95035 ♦ U.S.A.

Phone: +1 (408) 586 6200 ♦ Fax: +1 (408) 586 6299 ♦ E-mail: info@cetecomusa.com ♦ <http://www.cetecom.com>

CETECOM Inc. is a Delaware Corporation with Corporation number: 2905571

Table of Contents

1	Assessment	3
2	Administrative Data.....	4
3	Equipment under Test (EUT)	5
3.1	Specification of the Equipment under Test	5
3.2	Identification of the Equipment Under Test (EUT)	5
4	Subject of Investigation	6
5	Summary of Measurement Results.....	7
6	Measurements.....	8
6.1	RF Power Output.....	8
6.1.1	References	8
6.1.2	Measurement requirements:.....	8
6.1.3	Limits:	8
6.1.4	Radiated Output Power Measurement procedure.....	9
6.1.5	Conducted Output Power Measurement procedure	10
6.1.6	RF Power Output 1700MHz band.....	11
6.2	Occupied Bandwidth/Emission Bandwidth.....	12
6.2.1	References	12
6.2.2	Measurement requirements:.....	12
6.2.3	Limits:	12
6.2.4	Measurement procedure:	12
6.2.5	Occupied/Emission Bandwidth- FDD IV band	13
6.2.6	Results	14
6.3	Frequency Stability	17
6.3.1	References	17
6.3.2	Measurement requirements:.....	17
6.3.3	Limits.....	17
6.3.4	Method of Measurement:	17
6.3.5	Test Results Frequency Stability (FDD IV): Channel 1412 (1732.5 MHz).....	19
6.4	Conducted Spurious Emissions.....	20
6.4.1	References	20
6.4.2	Measurement requirements:.....	20
6.4.3	Limits.....	20
6.4.4	Measurement Procedure -Conducted Out of band Emissions	21
6.4.5	Measurement settings:.....	21
6.5	Emissions Radiated	25
6.5.1	References	25
6.5.2	Measurement requirements:.....	25
6.5.3	Limits:	25
6.5.4	Radiated out of band measurement procedure:	27
6.5.5	Sample Calculations for Radiated Measurements	28
6.5.6	Measurement Survey:	28
6.5.7	Radiated out of band emissions results on EUT- Transmit Mode:	29
7	Test Equipment and Ancillaries used for tests.....	36
8	Test Setup Diagrams	37
9	Revision History	38



1 Assessment

The following equipment (and as identified in Ch.3 of this test report) was evaluated against the applicable criteria specified in FCC CFR47 Parts 2, and 27 & Industry Canada Radio Standard Specifications RSS 139 Issue 2 and no deviations were ascertained during the course of the tests performed.

Company	Description	Model Name
u-blox AG	GSM/WCDMA/HSPA Data and Voice Module	LISA-U200

Responsible for Testing Laboratory:

2012-10-24	Compliance	Sajay Jose (Test Lab Manager)	Josie Sabado (EMC Engineer) On behalf of Sajay Jose
Date	Section	Name	Signature

Responsible for the Report:

2012-10-24	Compliance	David Lang (EMC Engineer)	
Date	Section	Name	Signature

The test results of this test report relate exclusively to the test item specified in Section3. CETECOM Inc. USA does not assume responsibility for any conclusions and generalizations drawn from the test results with regard to other specimens or samples of the type of the equipment represented by the test item. The test report may only be reproduced or published in full. Reproduction or publication of extracts from the report requires the prior written approval of CETECOM Inc. USA.

2 Administrative Data

2.1 Identification of the Testing Laboratory Issuing the Test Report

Company Name:	CETECOM Inc.
Department:	Compliance
Address:	411 Dixon Landing Road Milpitas, CA 95035 U.S.A.
Telephone:	+1 (408) 586 6200
Fax:	+1 (408) 586 6299
Test Lab Manager:	Sajay Jose
Test Engineer:	David Lang

2.2 Identification of the Client

Client:	u-blox AG
Street Address:	Zuercherstrasse 68
City/Zip Code	8800 Thalwil
Country	SWITZERLAND
Contact Person:	Giulio Comar
Phone No.	+39 040 2529400
Fax:	+39 040 2529 394
e-mail:	giulio.comar@u-blox.com

2.3 Identification of the Manufacturer

Manufacturer's Name:	Same as client.
Manufacturers Address:	
City/Zip Code	
Country	

3 Equipment under Test (EUT)

3.1 Specification of the Product

Marketing Name:	LISA-U200
Model Name:	LISA-U200
Product Description:	GSM/WCDMA/HSPA Data and Voice Module
Hardware Version :	146AB0
FW Version :	22.40*
FCC-ID:	XPYLISAU200
IC-ID:	8595A-LISAU200
Frequency bands of test:	FDD IV: 1712.4-1752.5MHz
Type(s) of Modulation:	QPSK
Number of channels:	FDD IV:203
Other radio bands supported:	GSM/GPRS/EGPRS 850/900/1800/1900 UMTS FDD Bands 800/850/900/1900/2100
Antenna Type and Gain:	EUT will not be sold with antenna. A $\lambda/4$ antenna was used for test purpose.
Rated Operating Voltage Range: (V)	$V_{\min} = 3.3\text{VDC}$ $V_{\text{nom}} = 3.8\text{VDC}$ $V_{\max} = 4.4\text{VDC}$
Rated Operating Temperature Range:	-20°C to + 65°C
Prototype / Production unit	Prototype

3.2 Identification of the Equipment Under Test (EUT)

EUT #	S/N	HW Version	FW Version	Model	Notes
1	127	146AB0	22.30*	LISA-U200	-/-

*Note: All testing was performed using EUT#1 with FW Ver. 22.30. Per manufacturer SW change declaration, FW Ver. 22.40 does not have any impact on the performance characteristics reported in this test report.

4 Subject of Investigation

The objective of the measurements applied by CETECOM Inc. was to establish compliance of the EUT as described under Ch. 3 of this Test Report, with the applicable criteria specified in

- 47 CFR Part 2: Title 47 of the Code of Federal Regulations: Chapter I-Federal Communications Commission Frequency allocations and radio treaty matters; general rules and regulations.
- 47 CFR Part 27: Title 47 of the Code of Federal Regulations: Chapter I-Federal Communications Commission subchapter B- common carrier services; Part 27- Miscellaneous wireless communication services
- RSS 139- Issue 2: Spectrum management and telecommunication policy- Radio Standards Specifications- Advance wireless services equipment operating in the bands 1710-1755MHz and 2110-2155MHz

All test results part of this report were performed to show compliance with the above mentioned standards for a class II permissive change.

5 Summary of Measurement Results

1700 MHz Band:

Test Specification	Test Case	Temperature and Voltage Conditions	Mode	Pass	Fail	NA	NP	Result
§2.1046 §27.50(d)(4) RSS139(6.4)	RF Output Power	Nominal	UMTS Band IV	■	□	□	□	Complies
§2.1055 §27.54 RSS139(6.3)	Frequency Stability	Nominal	UMTS Band IV	■	□	□	□	Complies
§2.1049 §27.53(h) RSS-Gen(4.6.1)	Occupied Bandwidth	Nominal	UMTS Band IV	■	□	□	□	Complies
§2.1051 §27.53(h) RSS139 6.5	Band Edge Compliance	Nominal	UMTS Band IV	■	□	□	□	Complies
§2.1051 §27.53(h) RSS139 6.5	Conducted Spurious Emissions	Nominal	UMTS Band IV	■	□	□	□	Complies
§2.1053 §27.53(h) RSS139 6.5	Radiated Spurious Emissions	Nominal	UMTS Band IV	■	□	□	□	Complies

Note: NA= Not Applicable;

6 Measurements

6.1 RF Power Output

6.1.1 References

FCC: CFR Part 2.1046, CFR Part 27.50
IC: RSS-Gen Section 4.8; RSS 139 Section 6.4

6.1.2 Measurement requirements:

6.1.2.1 FCC 2.1046: RF power output.

Power output shall be measured at the RF output terminals when the transmitter is adjusted in accordance with the tune-up procedure to give the values of current and voltage on circuit elements as specified. The electrical characteristics of the radio frequency load attached to the output terminals when this test is made shall be stated.

6.1.2.2 RSS-Gen 4.8: RF power output.

Transmitter output power measurements shall be carried out before the unwanted emissions test. The transmitter output power value, obtained from this test, serves as the reference level used to determine the unwanted emissions.

6.1.3 Limits:

6.1.3.1 FCC 27.50(d)(4) Power limits.

Fixed, mobile and portable (handheld stations) operating in the 1710-1755 MHz band are limited to 1 watt EIRP

6.1.3.2 RSS-139 Section 6.4

The average equivalent isotropically radiated power (e.i.r.p.) for fixed, mobile and portable transmitters in the 1710-1755 MHz shall not exceed 1 watt.

6.1.4 Radiated Output Power Measurement procedure

Ref: TIA-603C 2004 -2.2.17.2 Effective Radiated Power (ERP) or Effective Isotropic Radiated Power (EIRP)

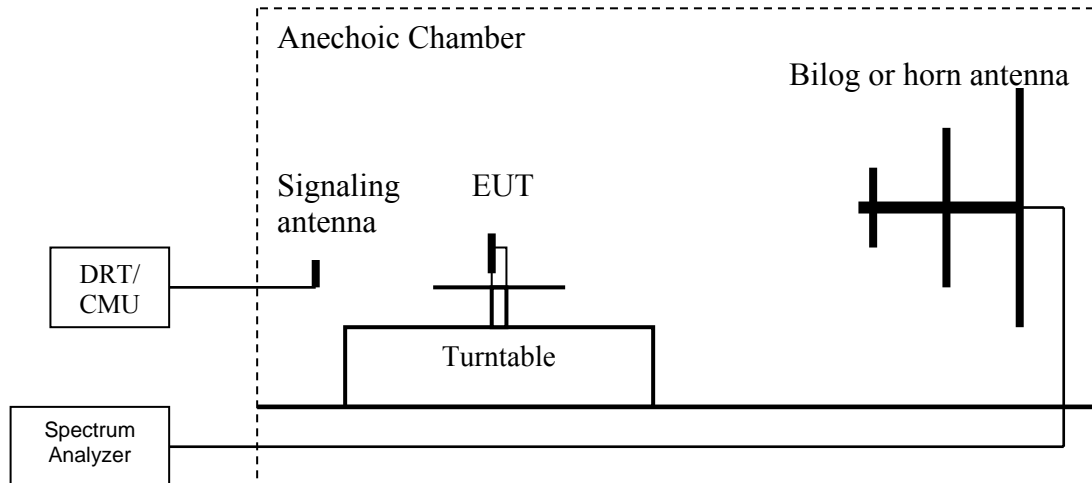

1. Connect the equipment as shown in the above diagram with the EUT's antenna in center of the turn table.
2. Adjust the settings of the Digital Radio Communication Tester (DRT) to set the EUT to its maximum power at the required channel.
3. Set the spectrum analyzer to the channel frequency. Set the analyzer to measure peak hold with the required settings.
4. Rotate the EUT 360°. Record the peak level in dBm (**LVL**).
5. Replace the EUT with a vertically polarized half wave dipole or known gain antenna. The center of the antenna should be at the same location as the center of the EUT's antenna.
6. Connect the antenna to a signal generator with known output power and record the path loss in dB (**LOSS**). **LOSS** = Generator Output Power (dBm) – Analyzer reading (dBm).
7. Determine the ERP using the following equation:
ERP (dBm) = LVL (dBm) + LOSS (dB)
8. Determine the EIRP using the following equation:
EIRP (dBm) = ERP (dBm) + 2.14 (dB)
9. Measurements are to be performed with the EUT set to the low, middle and high channel of each frequency band.

(**Note:** Steps 5 and 6 above are performed prior to testing and **LOSS** is recorded by test software. Steps 3, 4, 7 and 8 above are performed with test software.)

Measurement Uncertainty (Radiated): ±3.0 dB

6.1.5 Conducted Output Power Measurement procedure

Ref: TIA-603C 2004 2.2.1

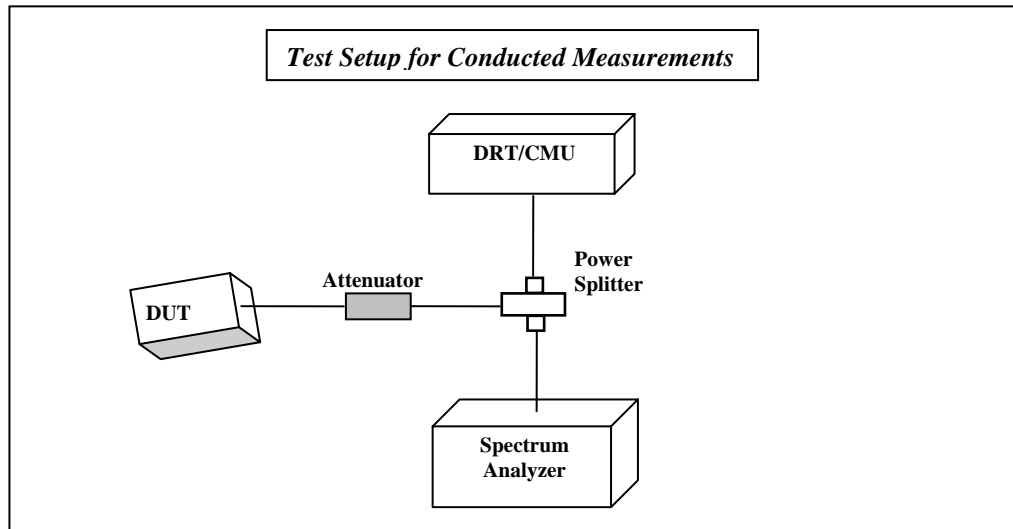

1. Connect the equipment as shown in the above diagram. A Digital Radio Communication Tester (DRT: R&S CMU200 here) is used to enable the EUT to transmit and to measure the output power.
 2. Adjust the settings of the CMU200 to set the EUT to its maximum power at the required channel.
 3. Record the Peak and Average Output power level measured by the CMU200.
 4. Correct the measured level for all losses in the RF path.
 5. Measurements are to be performed with the EUT set to the low, middle and high channel of each frequency band and for all types of modulation schemes.
- Measurement Uncertainty (Radiated): ± 0.5 dB

6.1.6 RF Power Output 1700MHz band

Limits: Nominal Peak Output Power < 30 dBm (1W)

FDD IV 1700 (UMTS Mode)				
Frequency (MHz)	Conducted Peak Power	Conducted Average Power	Peak to Average ratio	Radiated Power
				EIRP (dBm)
1712.4	25.6	22.6	1.13	18.5
1732.5	25.6	22.6	1.13	18.5
1752.5	25.7	22.7	1.13	17.7

6.1.6.1 Measurement Result

Pass.

6.2 Occupied Bandwidth/Emission Bandwidth

6.2.1 References

FCC: CFR Part 2.1049
IC: RSS-Gen Section 4.6

6.2.2 Measurement requirements:

6.2.2.1 **FCC 2.1049: Occupied bandwidth**

The occupied bandwidth, that is the frequency bandwidth such that, below its lower and above its upper frequency limits, the mean powers radiated are each equal to 0.5 percent of the total mean power radiated by a given emission shall be measured under the following conditions as applicable.

(h) Transmitters employing digital modulation techniques-when modulated by an input signal such that its amplitude and symbol rate represent the maximum rated conditions under which the equipment will be operated.

6.2.2.2 **RSS-Gen 4.6: Occupied bandwidth**

When an occupied bandwidth value is not specified in the applicable RSS, the transmitted signal bandwidth to be reported is to be its 99 percent emission bandwidth, as calculated or measured. The transmitter shall be operated at its maximum carrier power measured under normal test conditions.

6.2.3 Limits:

For reporting purposes only.

6.2.4 Measurement procedure:

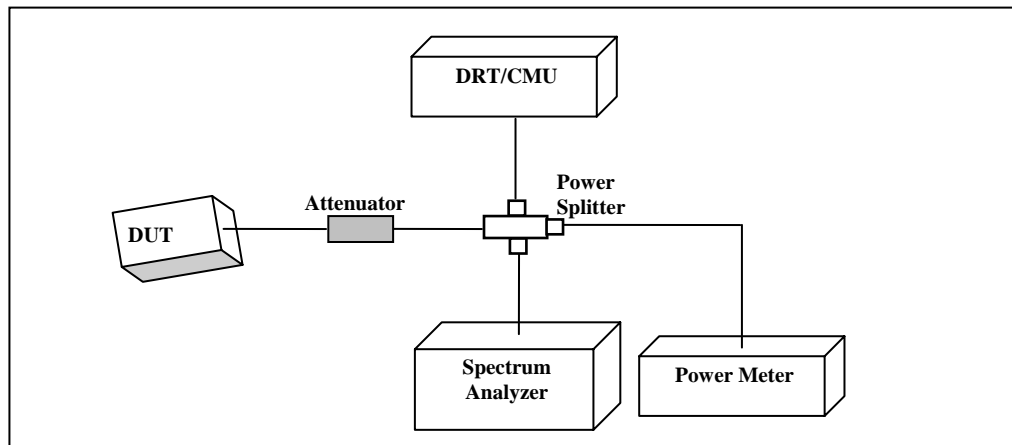

1. Connect the equipment as shown in the above diagram.
2. Adjust the settings of the Digital RadioCommunication Tester (DRT) to set the EUT to its maximum power at the required channel.
3. Set the spectrum analyzer to measure the 99% (-20 dB) occupied bandwidth.
4. Set the spectrum analyzer to measure the -26 dB emission bandwidth.
5. Measurements are to be performed with the EUT set to the low, middle and high channel of each frequency band.



6.2.5 Occupied/Emission Bandwidth- FDD IV band

FDD IV 1700 (UMTS Mode)		
Frequency (MHz)	99% Occupied Bandwidth (kHz)	-26dBc Bandwidth (kHz)
1712.4	4076.92	4625.00
1732.5	4067.30	4644.23
1752.5	4067.30	4634.62

6.2.6 Results

Occupied band Width FDD IV 1700 (UMTS Mode) 1712.4 MHz

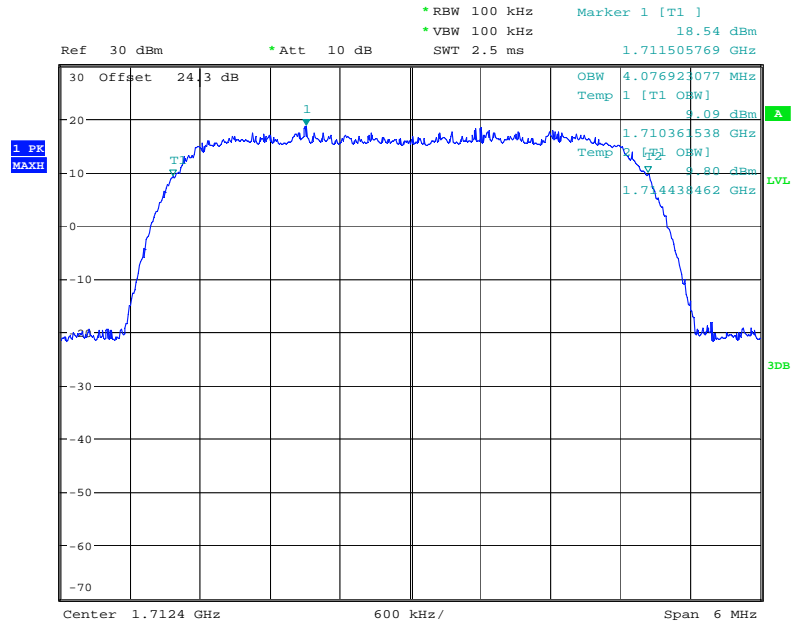

Date: 20.JUN.2012 15:40:33

Occupied band Width FDD IV 1700 (UMTS Mode) 1732.5 MHz

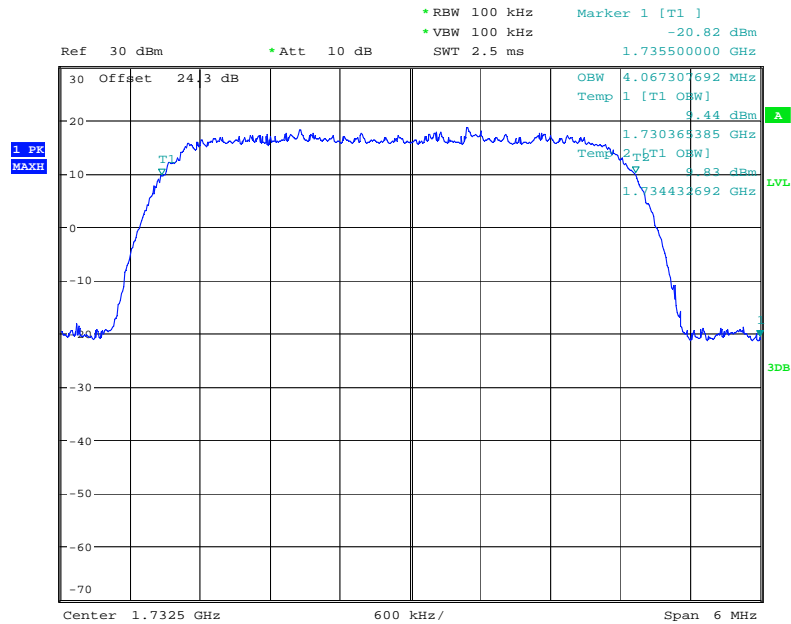

Date: 20.JUN.2012 15:38:35

Occupied band Width FDD IV 1700 (UMTS Mode) 1752.5 MHz

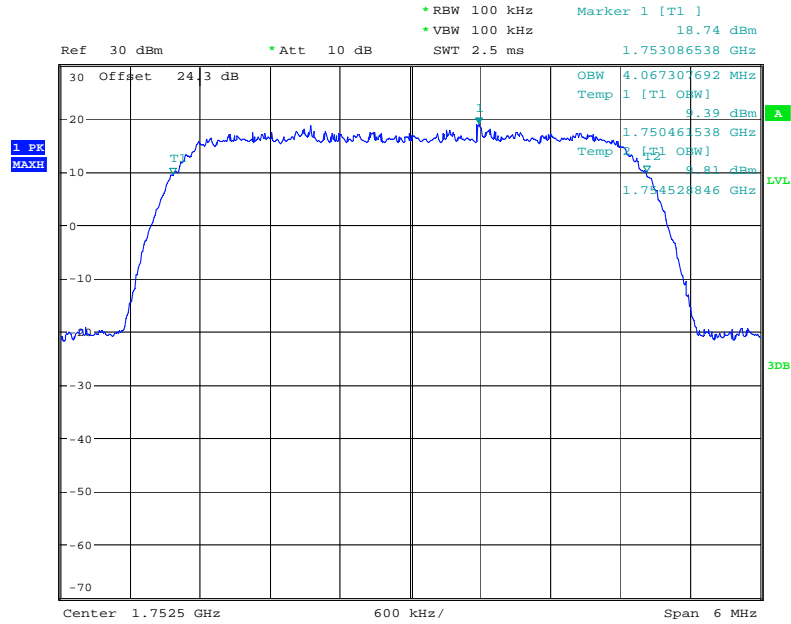

Date: 20.JUN.2012 15:36:37

Emission band Width FDD IV 1700 (UMTS Mode) 1712.4 MHz

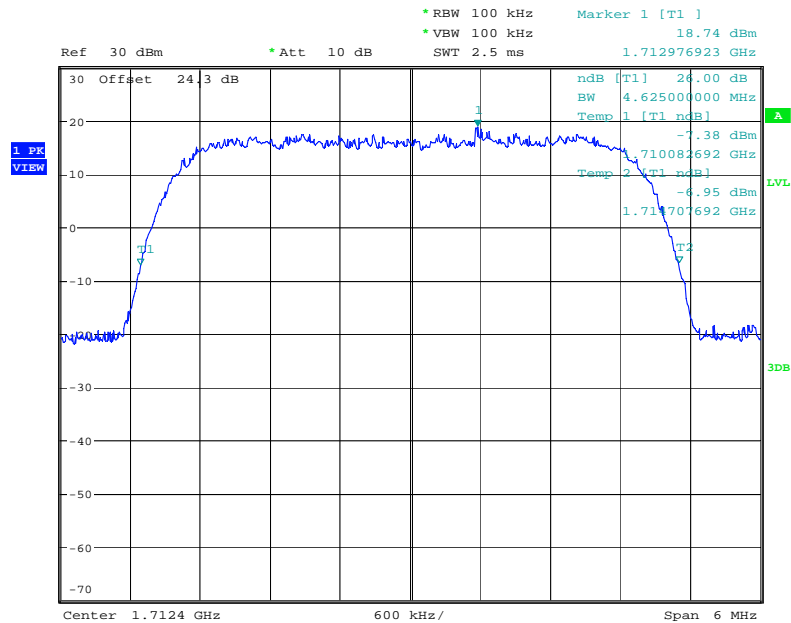

Date: 20.JUN.2012 15:52:13

Emission band Width FDD IV 1700 (UMTS Mode) 1732.5 MHz

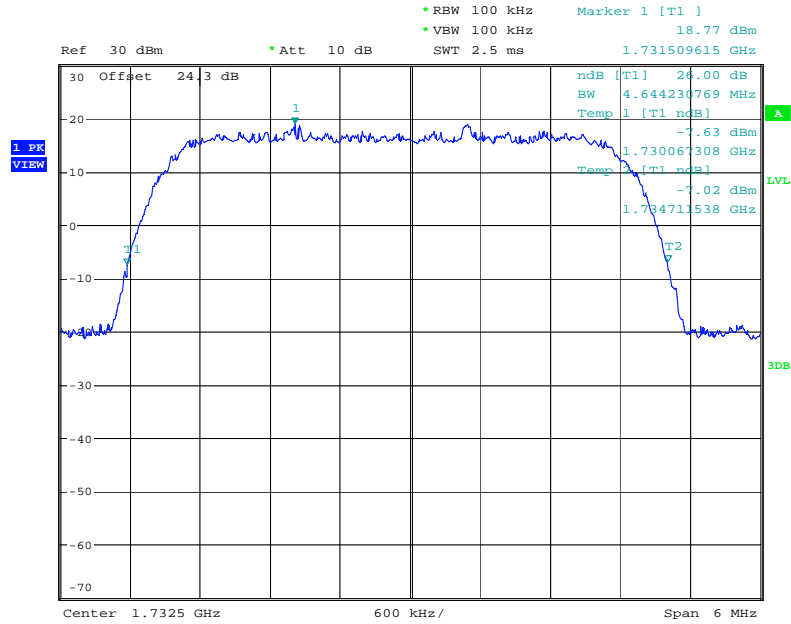

Date: 20.JUN.2012 15:54:13

Emission band Width FDD IV 1700 (UMTS Mode) 1752.5 MHz

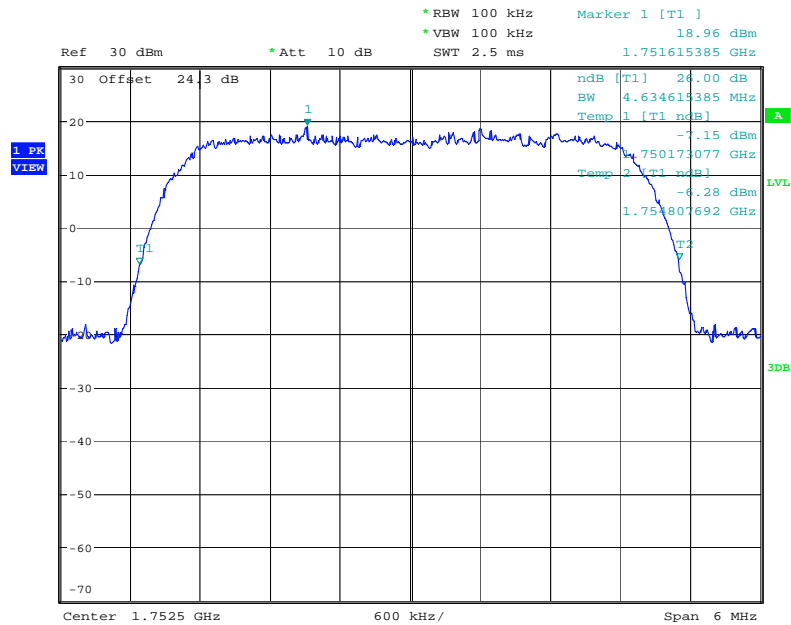

Date: 20.JUN.2012 15:56:05

6.3 Frequency Stability

6.3.1 References

FCC: CFR Part 2.1055, CFR Part 27.54
IC: RSS-Gen Section 4.7; RSS 139 Section 6.3

6.3.2 Measurement requirements:

6.3.2.1 Frequency Stability

Frequency stability is a measure of frequency drift due to temperature and supply voltage variations with reference to the frequency measured at an appropriate reference temperature and the rated supply voltage.

A hand-held device that is only capable of operating using internal batteries shall be tested using a new battery without any further requirement to vary the supply voltage. Alternatively, an external supply voltage can be used and set at the battery nominal voltage, and again at the battery operating end point voltage which shall be specified by the equipment manufacturer.

6.3.3 Limits

The frequency stability shall be sufficient to ensure that the fundamental emissions stay within the authorized bands of operation.

This transceiver is specified to operate with an input voltage of between 3.2VDC and 4.4VDC, with a nominal voltage of 3.8VDC. Operation above or below these voltage limits is prohibited by transceiver software in order to prevent improper operation as well as to protect components from overstress. These voltages represent a tolerance of -15.8% and +10.5%. For the purposes of measuring frequency stability these voltage limits are to be used.

6.3.3.1 For equipment powered by primary supply voltage:

For this EUT section 2.1055(d)(1) applies. This requires to vary primary supply voltage from 85 to 115 percent of the nominal value for other than hand carried battery equipment.

6.3.4 Method of Measurement:

In order to measure the carrier frequency under the condition of AFC lock, it is necessary to make measurements with the EUT in a "call mode". This is accomplished with the use of R&S CMU 200 Universal Radio Communication Tester.

1. Measure the carrier frequency at room temperature.
2. Subject the EUT to soak at -30 C.
3. With the EUT, powered via nominal voltage, connected to the CMU 200 and in a simulated call on mid channel (Ch. 1412 in FDD IV mode), measure the carrier frequency. These measurements should be made within 2 minutes of powering up the EUT, to prevent significant self-warming.
4. Repeat the above measurements at 10 C increments from -30 C to +50 C. Allow at least 1 1/2 hours at each temperature, un-powered, before making measurements.
5. Re-measure carrier frequency at room temperature with nominal voltage. Re-measure carrier frequency at low and high voltage. Pause at nominal voltage for 1 1/2 hours un-powered, to allow any self-heating to stabilize, before continuing.

6. Subject the EUT to soak at +50 C.
 3. With the EUT, powered via nominal voltage, connected to the CMU 200 and in a simulated call on mid channel (Ch. 1412 in FDD IV mode), measure the carrier frequency. These measurements should be made within 2 minutes of powering up the EUT, to prevent significant self-warming.
 8. Repeat the above measurements at 10 C increments from +50 C to -30 C. Allow at least 1 1/2 hours at each temperature, un-powered, before making measurements.
 9. At all temperature levels hold the temperature to +/- 0.5 C during the measurement procedure.
- Measurement uncertainty= +/- 0.01 Hz

6.3.5 Test Results Frequency Stability (FDD IV): Channel 1412 (1732.5 MHz)

Voltage (V)	Frequency Error (Hz)	Frequency Error (ppm)
Low V: 3.23	15	0.008
High V: 4.37	11	0.006

§2.1055 (a)(1) AFC FREQ ERROR vs. TEMPERATURE

Temperature (°C)	Frequency Error (Hz)	Frequency Error (ppm)
-30	18	0.010
-20	14	0.008
-10	17	0.009
0	20	0.012
+10	16	0.009
+20	11	0.006
+30	15	0.008
+40	15	0.008
+50	12	0.007

§2.1055 (b)(2) Battery end point

Battery End Point (V DC)	Frequency Error (Hz)	Frequency Error (ppm)
3.20	15	0.008

6.3.5.1 Measurement Result

Pass.

6.4 Conducted Spurious Emissions

6.4.1 References

FCC: CFR Part 2.1051, CFR Part 27.53
IC: RSS-Gen Section 4.9; RSS 139 Section 6.5

6.4.2 Measurement requirements:

6.4.2.1 FCC 2.1051: Spurious emissions at antenna terminals.

The radio frequency voltage or power generated within the equipment and appearing on a spurious frequency shall be checked at the equipment output terminals when properly loaded with a suitable artificial antenna. Curves or equivalent data shall show the magnitude of each harmonic and other spurious emission that can be detected when the equipment is operated under the conditions specified in FCC 2.1049 as appropriate. The magnitude of spurious emissions which are attenuated more than 20 dB below the permissible value need not be specified.

6.4.2.2 RSS-Gen 4.9: Transmitter unwanted spurious emissions

The same parameter, peak power or average power, used for the transmitter output power measurement shall be used for unwanted emission measurements.

The search for unwanted emissions shall be from the lowest frequency internally generated or used in the device (local oscillator, intermediate or carrier frequency), or from 30 MHz, whichever is the lower, to the 5th harmonic of the highest frequency generated without exceeding 40 GHz.

6.4.3 Limits

(a) *Out of band emissions.* The power of any emission outside of the authorized operating frequency ranges must be attenuated below the transmitting power (P) by a factor of at least $43 + 10 \log(P)$ dB.

For all power levels +30dBm to 0dBm, this becomes a constant specification of -13dBm.

6.4.4 Measurement Procedure -Conducted Out of band Emissions

Ref: TIA-603C 2004 2.2.13 Unwanted Emissions: Conducted Spurious

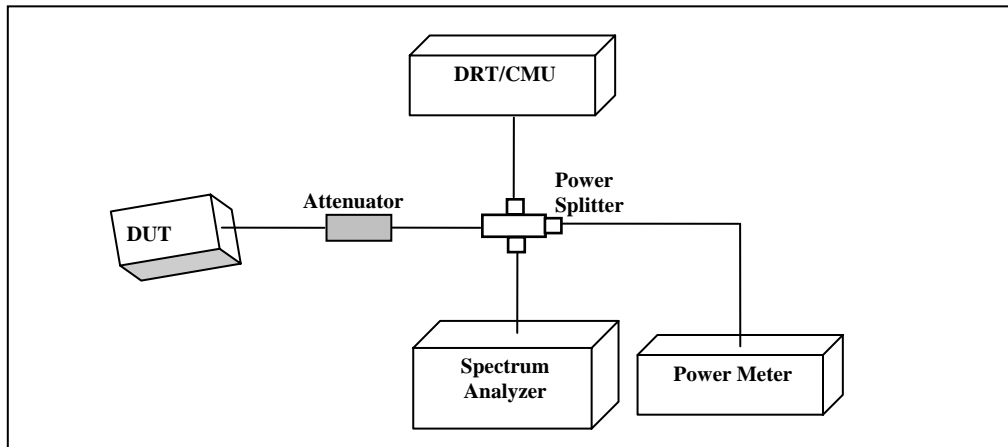

1. Connect the equipment as shown in the above diagram.
2. Set the spectrum analyzer to measure peak hold with the required settings.
3. Set the signal generator to a known output power and record the path loss in dB (**LOSS**) for frequencies up to the tenth harmonic of the EUT's carrier frequency. \ **LOSS** = Generator Output Power (dBm) – Analyzer reading (dBm).
4. Replace the signal generator with the EUT.
5. Adjust the settings of the Digital RadioCommunication Tester (DRT) to set the EUT to its maximum power at the required channel.
6. Set the spectrum analyzer to measure peak hold with the required settings. Offset the spectrum analyzer reference level by the path loss measured above.
7. Measure and record all spurious emissions up to the tenth harmonic of the carrier frequency.
8. Measurements are to be performed with the EUT set to the low, middle and high channel of each frequency band.
9. If necessary steps 6 and 7 may be performed with the spectrum analyzer set to average detector.

6.4.5 Measurement settings:

Conducted spurious emissions:

RBW/VBW=1MHz; Span=To cover 10th harmonic; Detector: Peak- Max Hold.

Band edge emissions:

FDD IV: RBW/VBW=1% of Emission BW; Sweep time= Auto; Detector: Peak- Max Hold.

Measurement Uncertainty: ±0.5 dB

6.4.5.1 **Measurement Result**

Pass.



Conducted Out of band Emission FDD IV 1700 (UMTS Mode) 1712.4 MHz

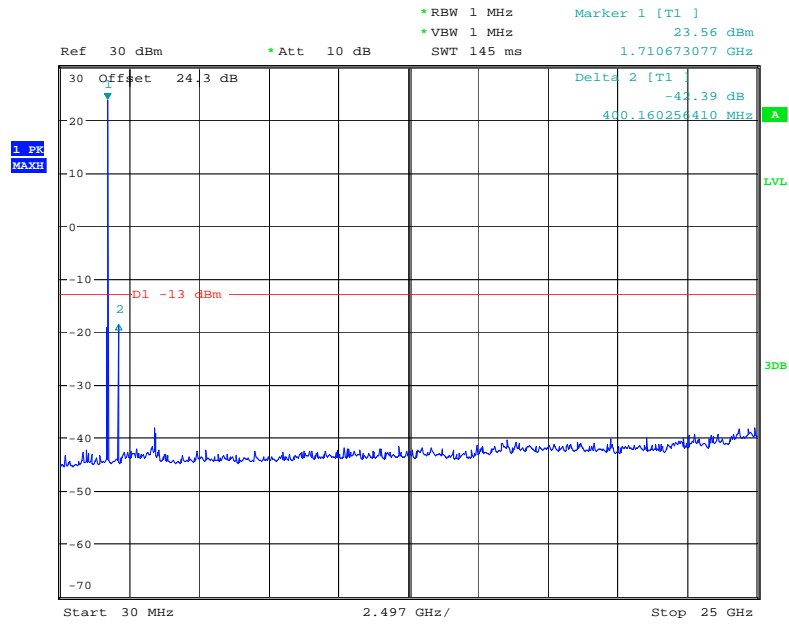

Date: 20.JUN.2012 15:49:25

Conducted Out of band Emission FDD IV 1700 (UMTS Mode) 1732.5 MHz

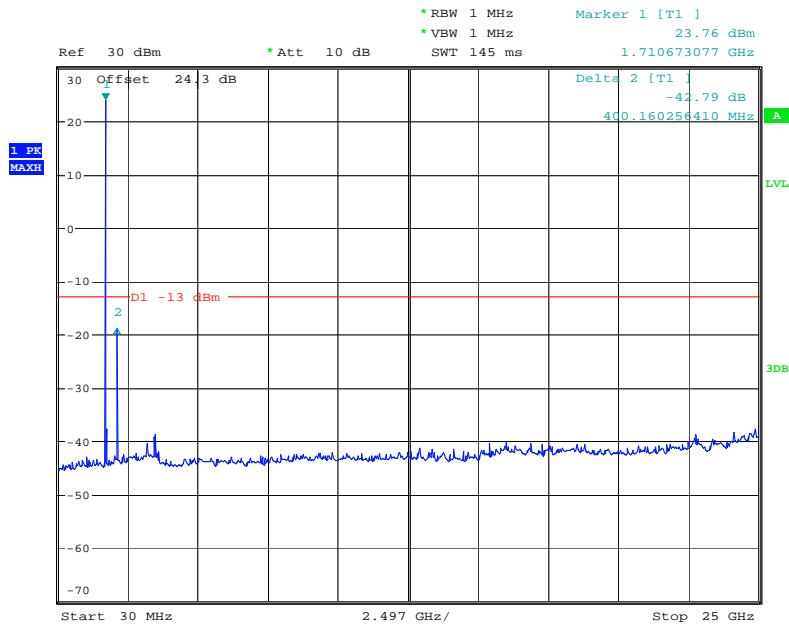

Date: 20.JUN.2012 15:48:30



Conducted Out of band Emission FDD IV 1700 (UMTS Mode) 1752.5 MHz

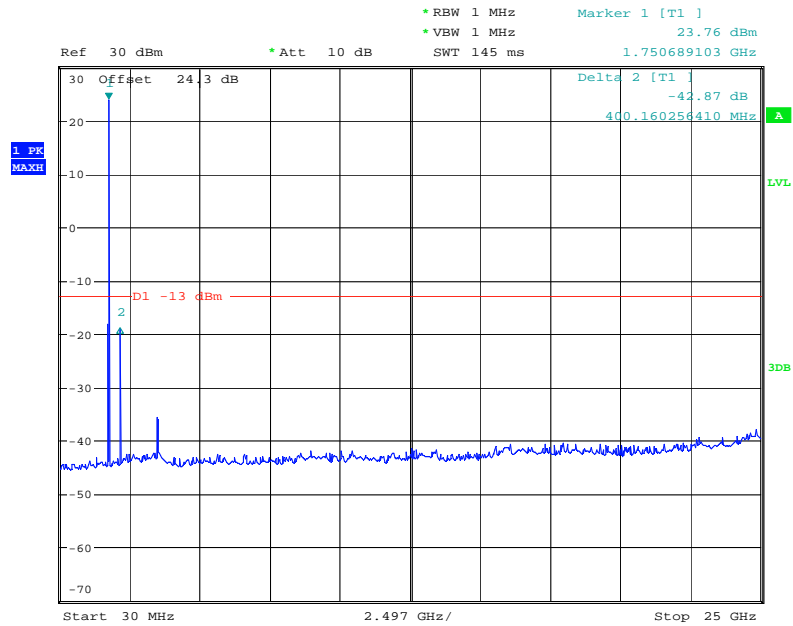

Date: 20.JUN.2012 15:47:28



Lower Band Edge FDD IV 1700 (UMTS Mode) 1712.4 MHz

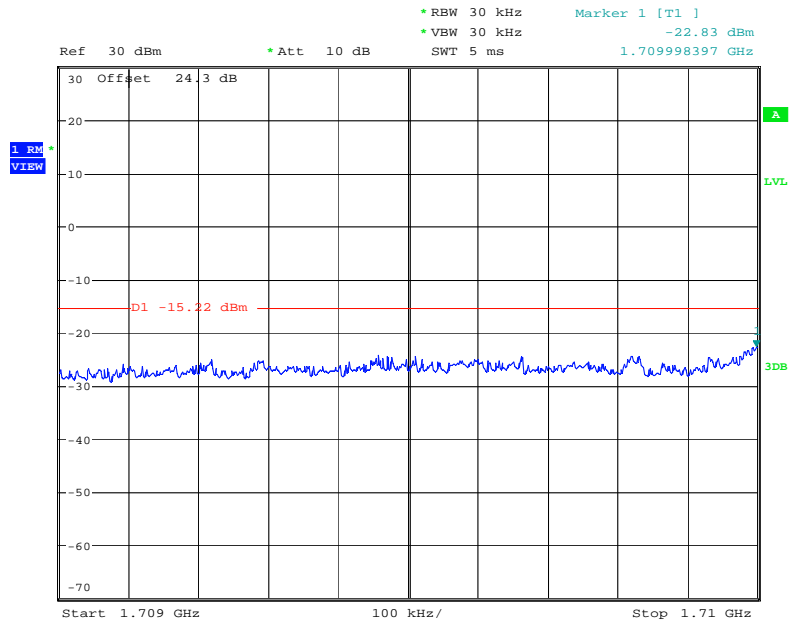

Date: 20.JUN.2012 16:03:51

Upper Band Edge FDD IV 1700 (UMTS Mode) 1752.5 MHz

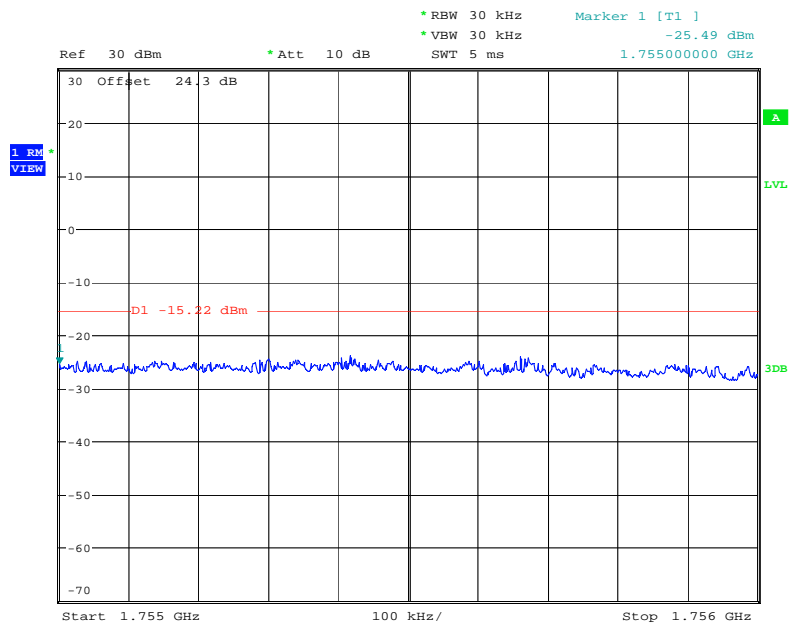

Date: 20.JUN.2012 16:02:12

6.5 Emissions Radiated

6.5.1 References

FCC: CFR Part 2.1053, CFR Part 27.53
IC: RSS-Gen Section 4.9; RSS 139 Section 6.5

6.5.2 Measurement requirements:

6.5.2.1 FCC 2.1053: Field strength of spurious radiation.

Measurements shall be made to detect spurious emissions that may be radiated directly from the cabinet, control circuits, power leads or intermediate circuit elements under normal conditions of installation and operation. Curves or equivalent data shall be supplied showing the magnitude of each harmonic and other spurious emission.

6.5.2.2 RSS-Gen 4.9: Transmitter unwanted spurious emissions

The same parameter, peak power or average power, used for the transmitter output power measurement shall be used for unwanted emission measurements.

The search for unwanted emissions shall be from the lowest frequency internally generated or used in the device (local oscillator, intermediate or carrier frequency), or from 30 MHz, whichever is the lower, to the 5th harmonic of the highest frequency generated without exceeding 40 GHz.

6.5.3 Limits:

(a) *Out of band emissions.* The power of any emission outside of the authorized operating frequency ranges must be attenuated below the transmitting power (P) by a factor of at least $43 + 10 \log(P)$ dB.

For all power levels +30dBm to 0dBm, this becomes a constant specification of -13dBm.

6.5.3.1 Emission limitations

Measurement procedure. Compliance with these provisions is based on the use of measurement instrumentation employing a resolution bandwidth of 100 kHz or greater. In the 1 MHz bands immediately outside and adjacent to the frequency block a resolution bandwidth of at least one percent of the emission bandwidth of the fundamental emission of the transmitter may be employed. A narrower resolution bandwidth is permitted in all cases to improve measurement accuracy provided the measured power is integrated over the full required measurement bandwidth (*i.e.* 100 kHz of 1 percent of emission bandwidth, as specified). The emission bandwidth is defined as the width of the signal between two points, one below the carrier center frequency and one above the carrier center frequency, outside of which all emissions are attenuated at least 26 dB below the transmitter power.

6.5.3.2 RSS-139 Section 6.5

In the first 1.0 MHz bands immediately outside and adjacent to the equipment's operating frequency block, the emission power per any 1% of the emission bandwidth shall be attenuated below the transmitter output power P (in watts) by at least $43 + 10 \log_{10}(P)$, dB.

After the first 1.0 MHz outside the equipment's operating frequency block, the emission power in any 1 MHz bandwidth shall be attenuated below the transmitter output power P (in watts) by at least $43 + 10 \log_{10}(P)$, dB.

6.5.4 Radiated out of band measurement procedure:

Ref: TIA-603C 2004- 2.2.12 Unwanted emissions: Radiated Spurious

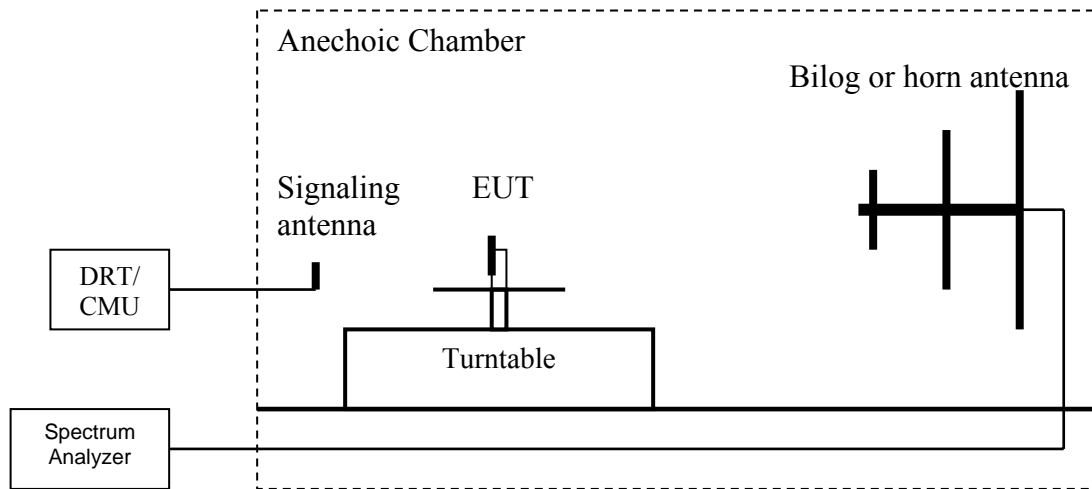

1. Connect the equipment as shown in the above diagram with the EUT's antenna in a horizontal orientation.
2. Adjust the settings of the Digital RadioCommunication Tester (DRT) to set the EUT to its maximum power at the required channel.
3. Set the spectrum analyzer to measure peak hold with the required settings.
4. Place the measurement antenna in a horizontal orientation. Rotate the EUT 360°. Raise the measurement antenna up to 4 meters in 0.5 meters increments and rotate the EUT 360° at each height to maximize all emissions. Measure and record all spurious emissions (**LVL**) up to the tenth harmonic of the carrier frequency.
5. Replace the EUT with a horizontally polarized half wave dipole or known gain antenna. The center of the antenna should be at the same location as the center of the EUT's antenna.
6. Connect the antenna to a signal generator with known output power and record the path loss in dB (**LOSS**). **LOSS** = Generator Output Power (dBm) – Analyzer reading (dBm).
7. Determine the level of spurious emissions using the following equation:
Spurious (dBm) = **LVL** (dBm) + **LOSS** (dB):
8. Repeat steps 4, 5 and 6 with all antennas vertically polarized.
9. Determine the level of spurious emissions using the following equation:
Spurious (dBm) = **LVL** (dBm) + **LOSS** (dB):
10. Measurements are to be performed with the EUT set to the low, middle and high channel of each frequency band.
(**Note:** Steps 5 and 6 above are performed prior to testing and **LOSS** is recorded by test software. Steps 3, 4 and 7 above are performed with test software.)

Spectrum analyzer settings: RBW=VBW=1MHz

6.5.5 Sample Calculations for Radiated Measurements

6.5.5.1 Power Measurements using Substitution Procedure:

1. The measurement from the Spectrum Analyzer is used as a basis for the Substitution procedure.
2. The EUT is replaced with a Signal Generator and an antenna. The setting on the Signal Generator is varied until the Spectrum Analyzer displays the reading as in Step 1.

Radiated Power (dBm)= Signal Generator setting (dBm)- Cable Loss (dB)+ Antenna Gain (dBi)

Eg:

Frequency (MHz)	Signal Generator setting (dBm)	Antenna Gain (dBi)	Cable Loss (dB)	EIRP (dBm)
1000	24.5	6.5	3.5	27.5

6.5.6 Measurement Survey:

Radiated emissions measurements were made at the upper, middle, and lower carrier frequencies of the AWS-1700.

For radiated measurements, all data in this report shows the worst case emissions data between H/V antenna polarizations and for all 3 orthogonal orientations of the EUT.

Unless mentioned otherwise, the emission signals above the limit line in the plots are from the carrier.

Measurement Uncertainty= +/- 3.0 dB.

6.5.7 Radiated out of band emissions results on EUT- Transmit Mode:

6.5.7.1 Test Results

Transmitter Spurious Emission UMTS FDD4:

Harmonic	Tx ch-1312 Freq. (MHz)	Level (dBm)	Tx ch-1413 Freq. (MHz)	Level (dBm)	Tx ch-1513 Freq. (MHz)	Level (dBm)
1	1712.4	15	1732.6	16	1752.6	-36
2	3424.8	-50	3465.2	NF	3505.2	-50
3	5137.2	-45	5197.8	-43	5257.8	-44
4	6849.6	NF	6930.4	NF	7010.4	NF
5	8562	NF	8663	NF	8763	NF
6	10274.4	NF	10395.6	NF	10515.6	NF
7	11986.8	NF	12128.2	NF	12268.2	NF
8	13699.2	NF	13860.8	NF	14020.8	NF
9	15411.6	NF	15593.4	NF	15773.4	NF
10	17124	NF	17326	NF	17526	NF
NF= Noise Floor Measurement Uncertainty: ±3dB						

6.5.7.2 Measurement Result

Pass.

Legend for the plots:

- -13dBm.LimitLine
- Preview Result
- * Data Reduction Result
- ◆ Final Measurement Result

Radiated Spurious Emissions (UMTS Band 4) Tx: Low Channel

Test results 30M-1GHz

FCC 27 30-1000MHz

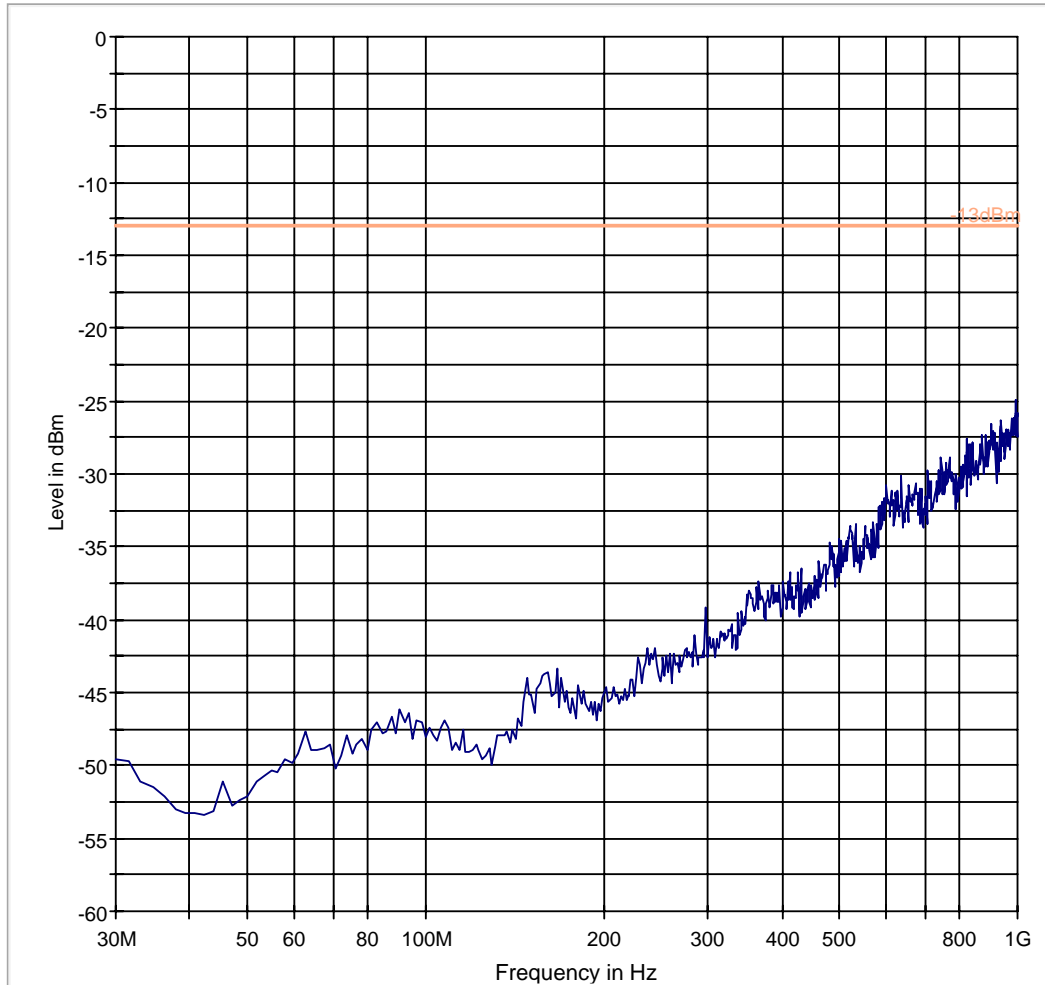

— -13dBm — Preview Result 1-PK+

Test results 1GHz-18GHz

Emission signal above the limit line in the plots is from the Carrier.

FCC 27 1-18GHz

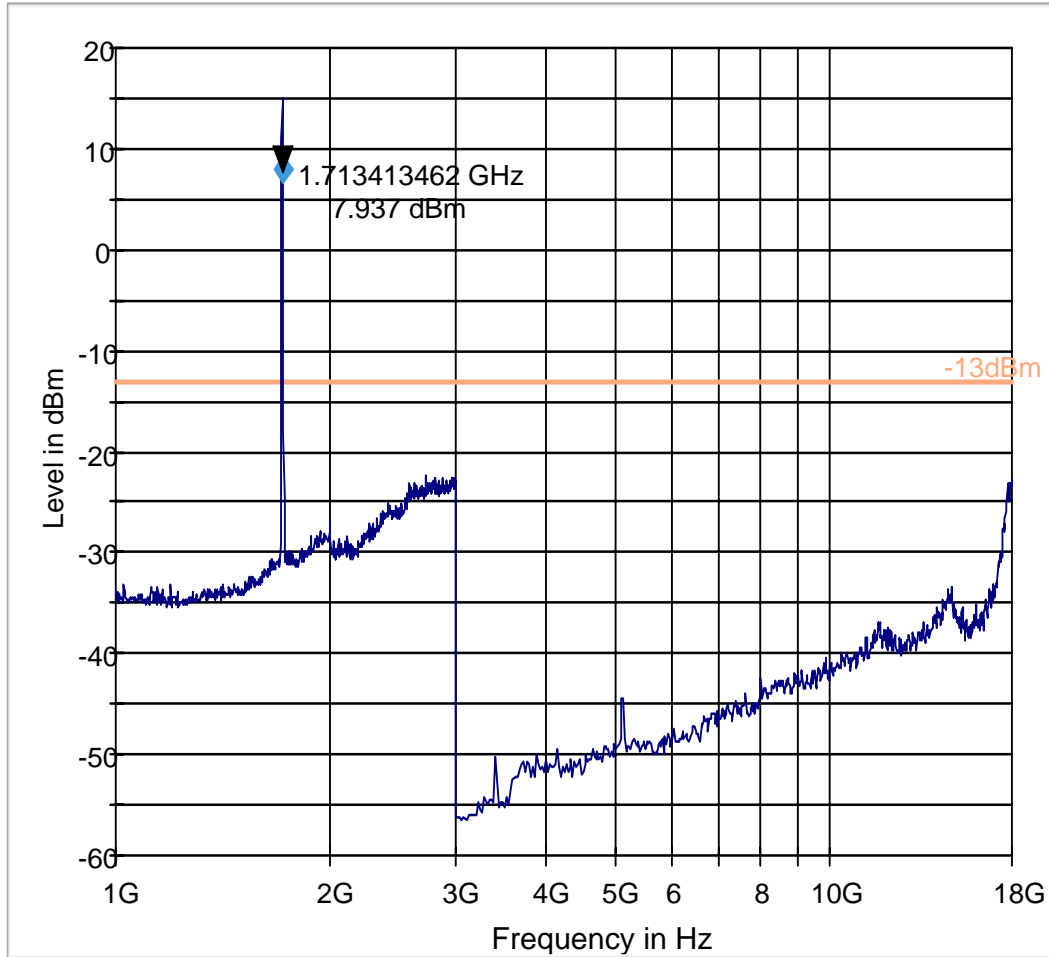

— -13dBm — Preview Result 1-PK+◆ Final Result 1-PK+

Radiated Spurious Emissions (UMTS Band 4) Tx: Mid Channel

Test results 30M-1GHz

FCC 27 30-1000MHz

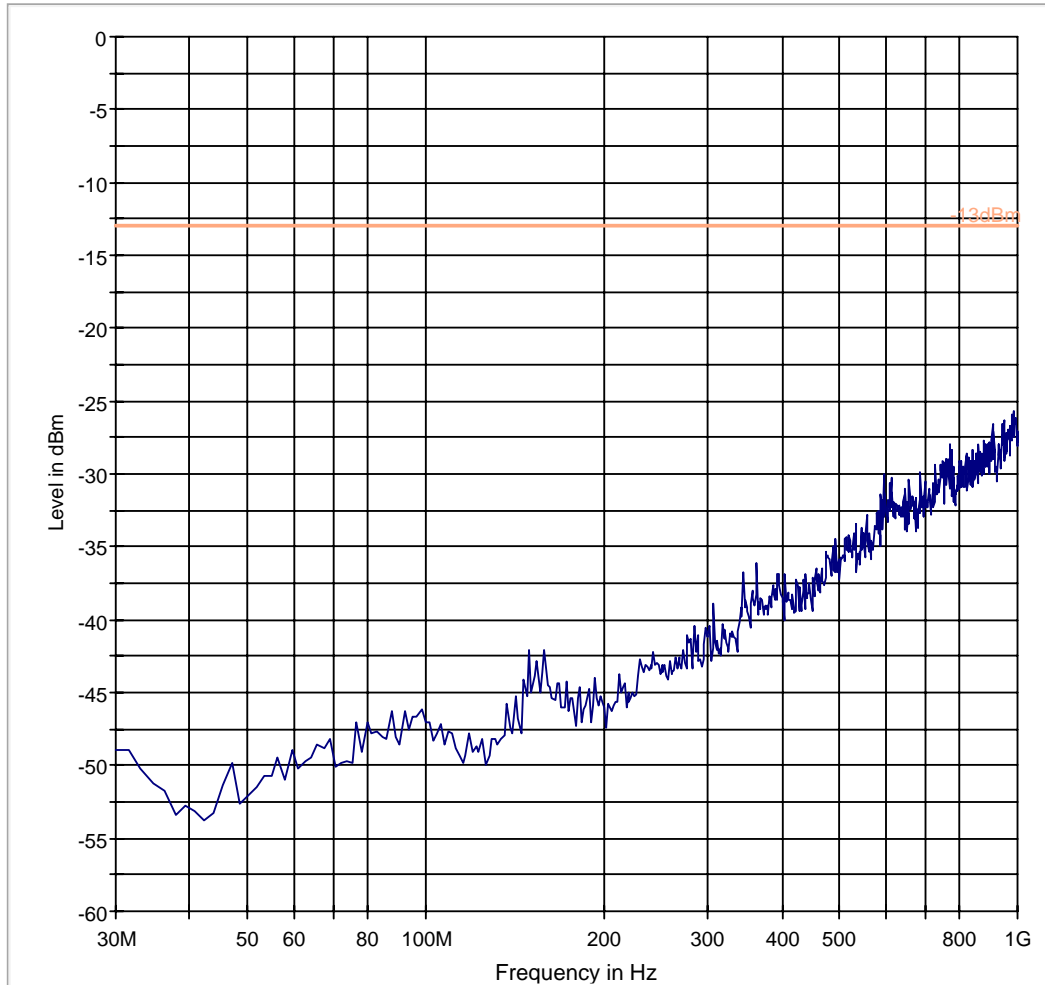

— -13dBm — Preview Result 1-PK+

Test results 1GHz-18GHz

Emission signal above the limit line in the plots is from the Carrier.

FCC 27 1-18GHz

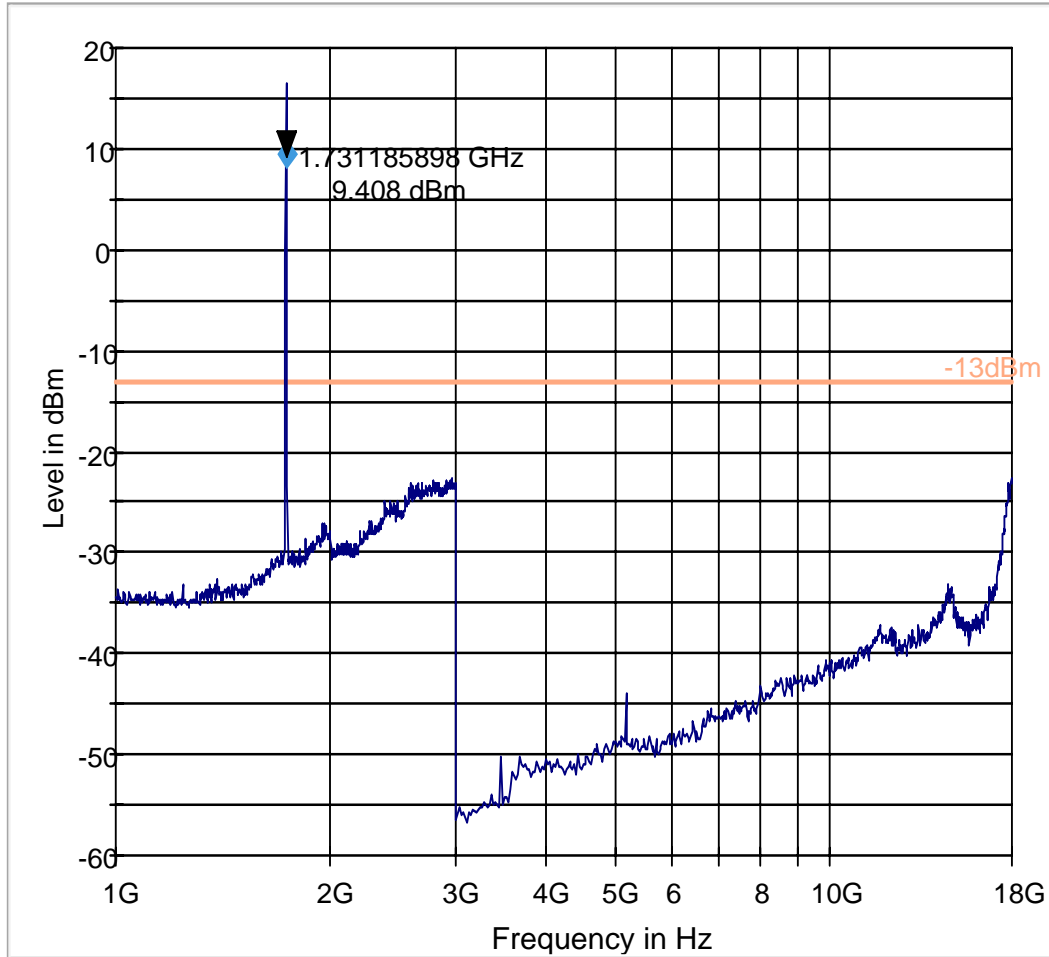

— -13dBm — Preview Result 1-PK+◆ Final Result 1-PK+

Radiated Spurious Emissions (UMTS Band 4) Tx: High Channel

Test results 30M-1GHz

FCC 27 30-1000MHz

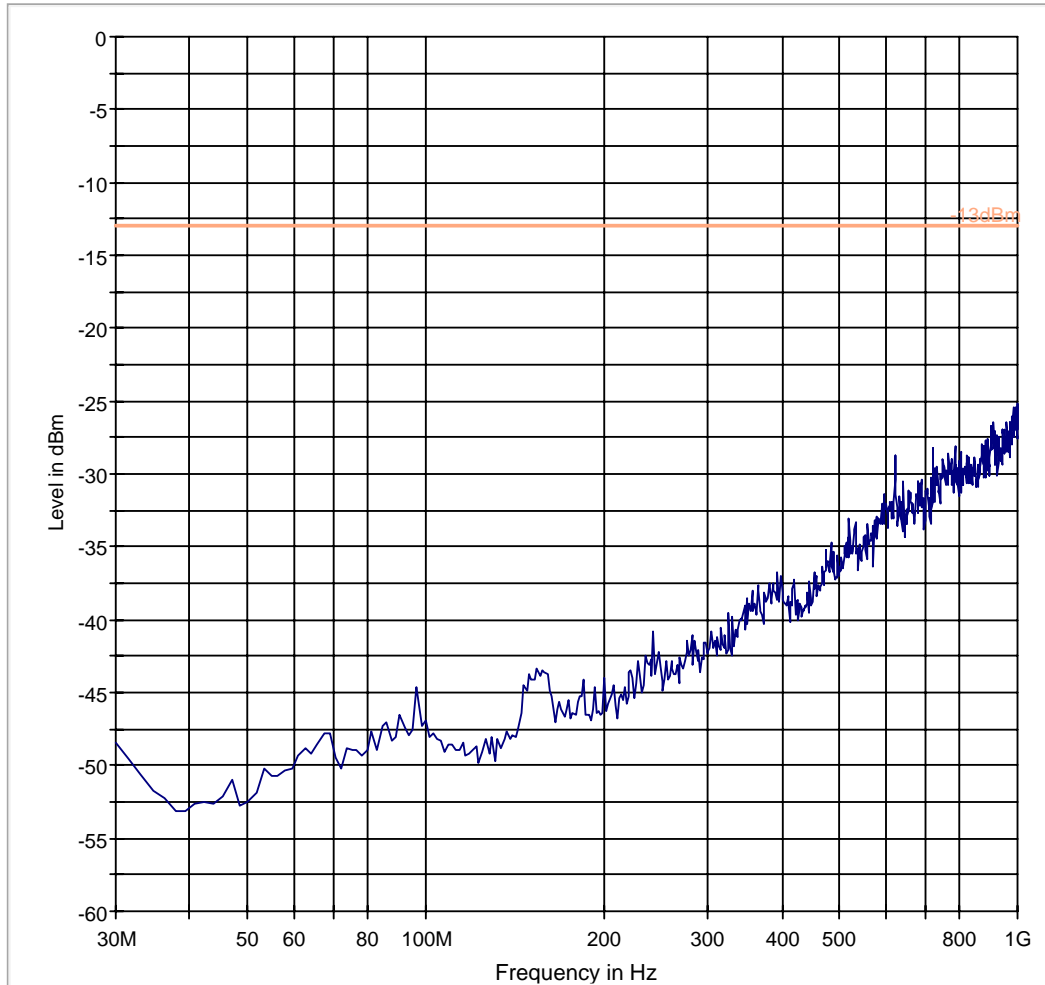

— -13dBm — Preview Result 1-PK+

Test results 1GHz-18GHz

Emission signal above the limit line in the plots is from the Carrier.

FCC 27 1-18GHz

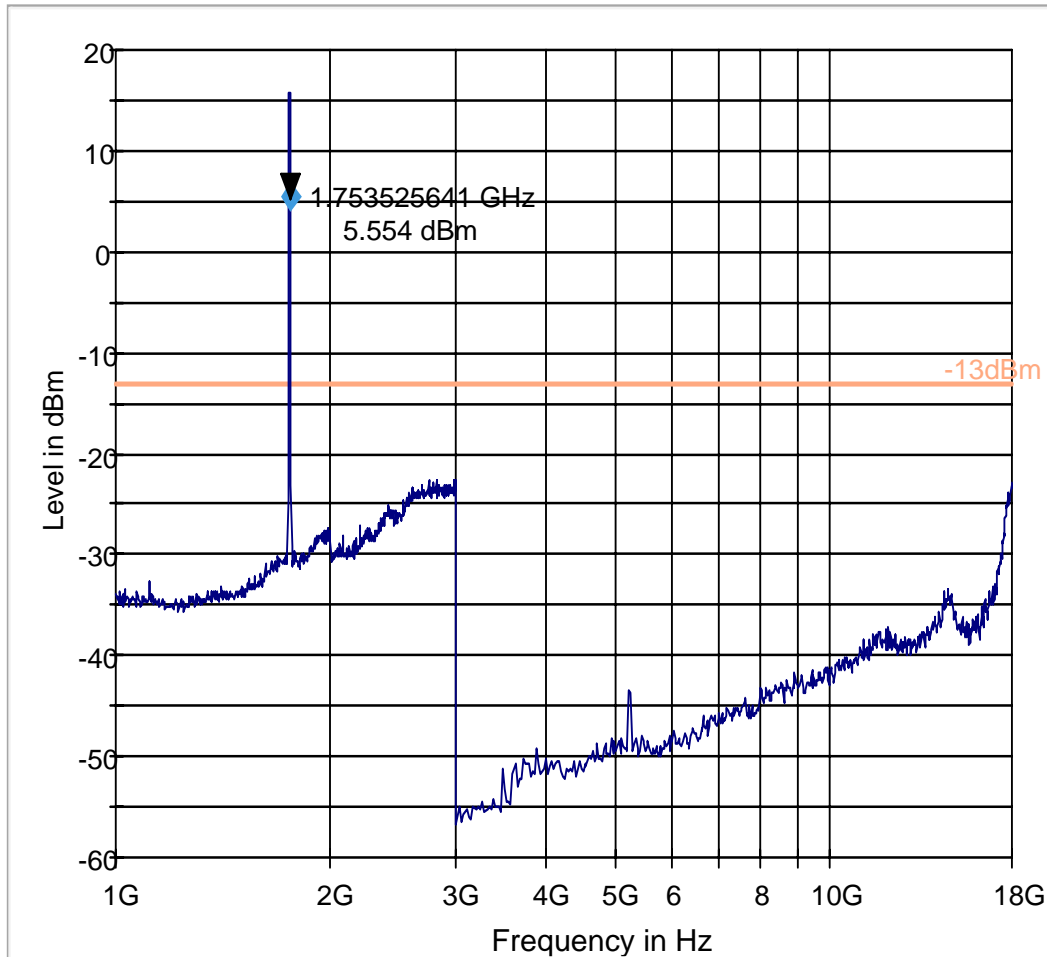

— -13dBm — Preview Result 1-PK+◆ Final Result 1-PK+

7 Test Equipment and Ancillaries used for tests

Instrument/Ancillary	Model	Manufacturer	Serial No.	Cal Date	Cal Interval
Radio Communication Tester	CMU 200	Rohde & Schwarz	101821	May 2011	2 Years
EMI Receiver/Analyzer	ESU 40	Rohde & Schwarz	100250	May 2012	1 Year
Spectrum Analyzer	FSU	Rohde & Schwarz	200302	May 2011	2 Years
Loop Antenna	6512	EMCO	00049838	Aug 2011	3 years
Biconilog Antenna	3141	EMCO	0005-1186	Apr 2012	3 years
Horn Antenna (1-18GHz)	3115	ETS	00035111	Apr 2012	3 years
Horn Antenna (18-40GHz)	3116	ETS	00070497	Sep 2011	3 years
Communication Antenna	IBP5-900/1940	Kathrein	n/a	n/a	n/a
High Pass Filter	5HC2700	Trilithic Inc.	9926013	Part of system calibration	
High Pass Filter	4HC1600	Trilithic Inc.	9922307	Part of system calibration	
6GHz High Pass Filter	HPM50106	Microtronics	001	Part of system calibration	
Pre-Amplifier	JS4-00102600	Miteq	00616	Part of system calibration	
LISN	50-25-2-08	FCC	08014	June 2011	2 Years
Power Smart Sensor	R&S	NRP-Z81	100161	May 2011	2 Years
Multimeter	MM200	Klein	N/A	Apr 2011	2 Years
Temp Hum Logger	TM320	Dickson	03280063	Mar 2012	1 Year
Temp Hum Logger	TM325	Dickson	5285354	Mar 2012	1 Year

8 Test Setup Diagrams

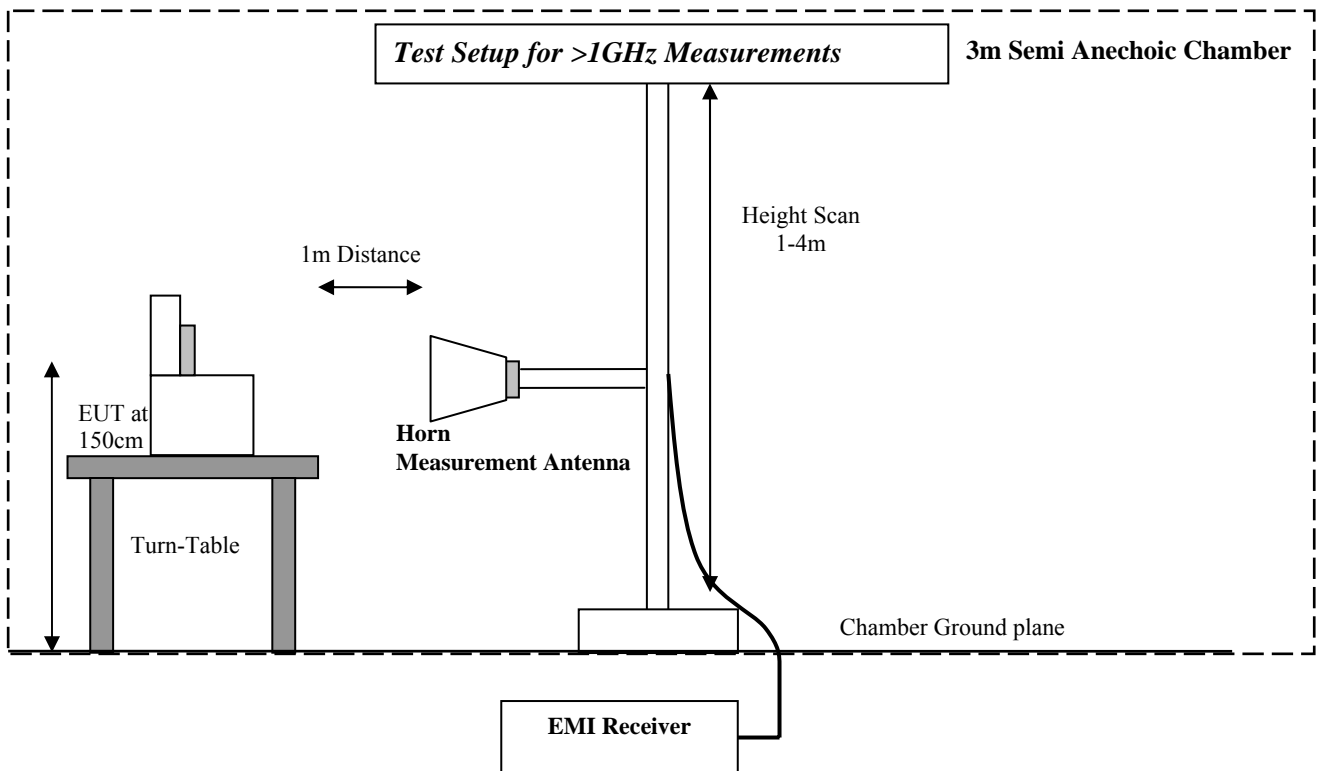
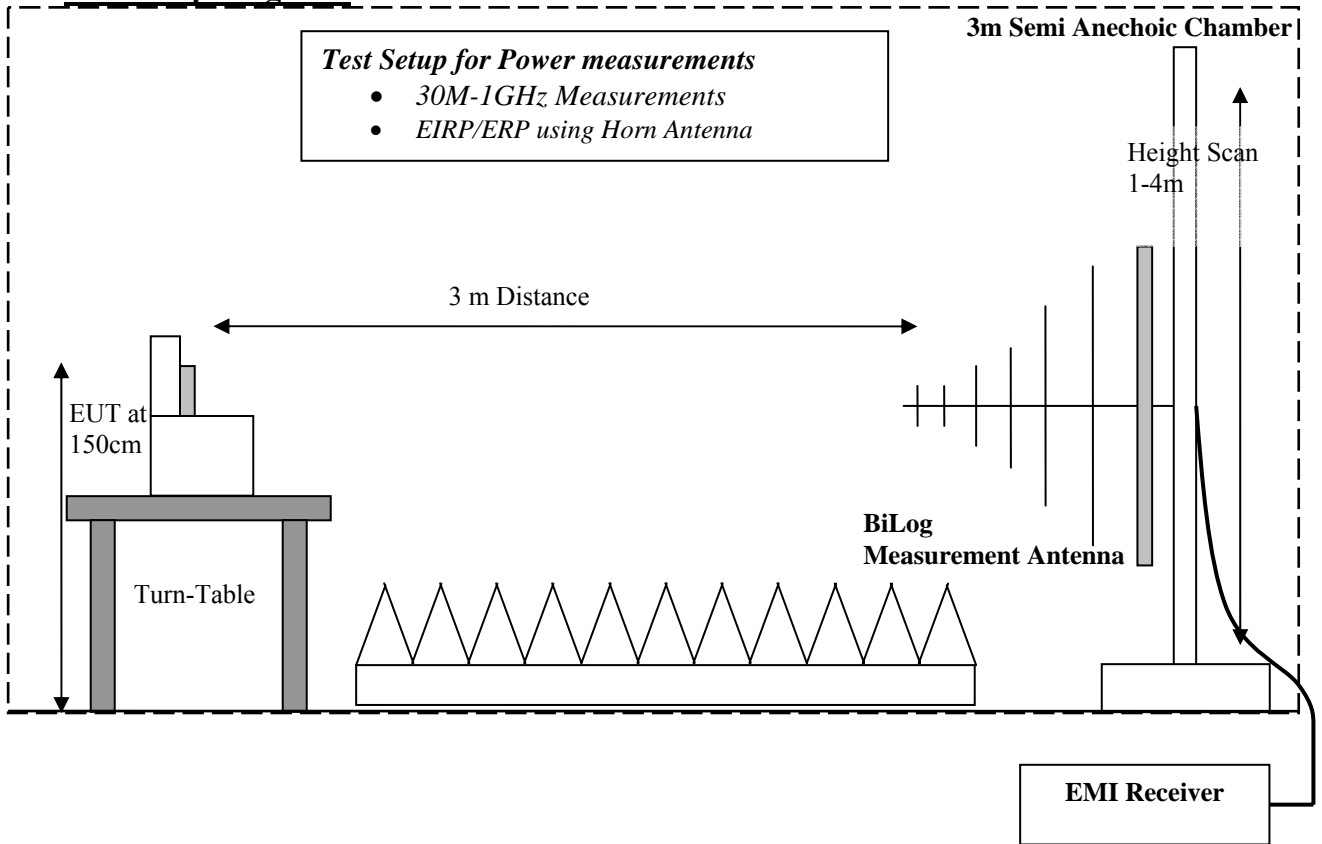



9 Revision History

Date	Report Name	Changes to report	Report prepared by
2012-07-05	EMC_CETEC_046_12001_WWAN	First Version	D.Lang
2012-07-21	EMC_CETEC_046_12001_WWAN_Rev1	Typo correction in Sec 2.2 and Product Description	D.Lang
2012-10-24	EMC_CETEC_046_12001_WWAN_Rev2	Statement regarding new equipment authorization in Sec.4 removed.	D.Lang