

EMC Block Diagram Form

System Configuration Block Diagram -- Provide a line drawing identifying the EUT, simulators, support equipment, I/O cables, power cables, and any other pertinent components to be used during testing. Use a dashed line to separate the equipment in the testing field versus equipment outside testing field.

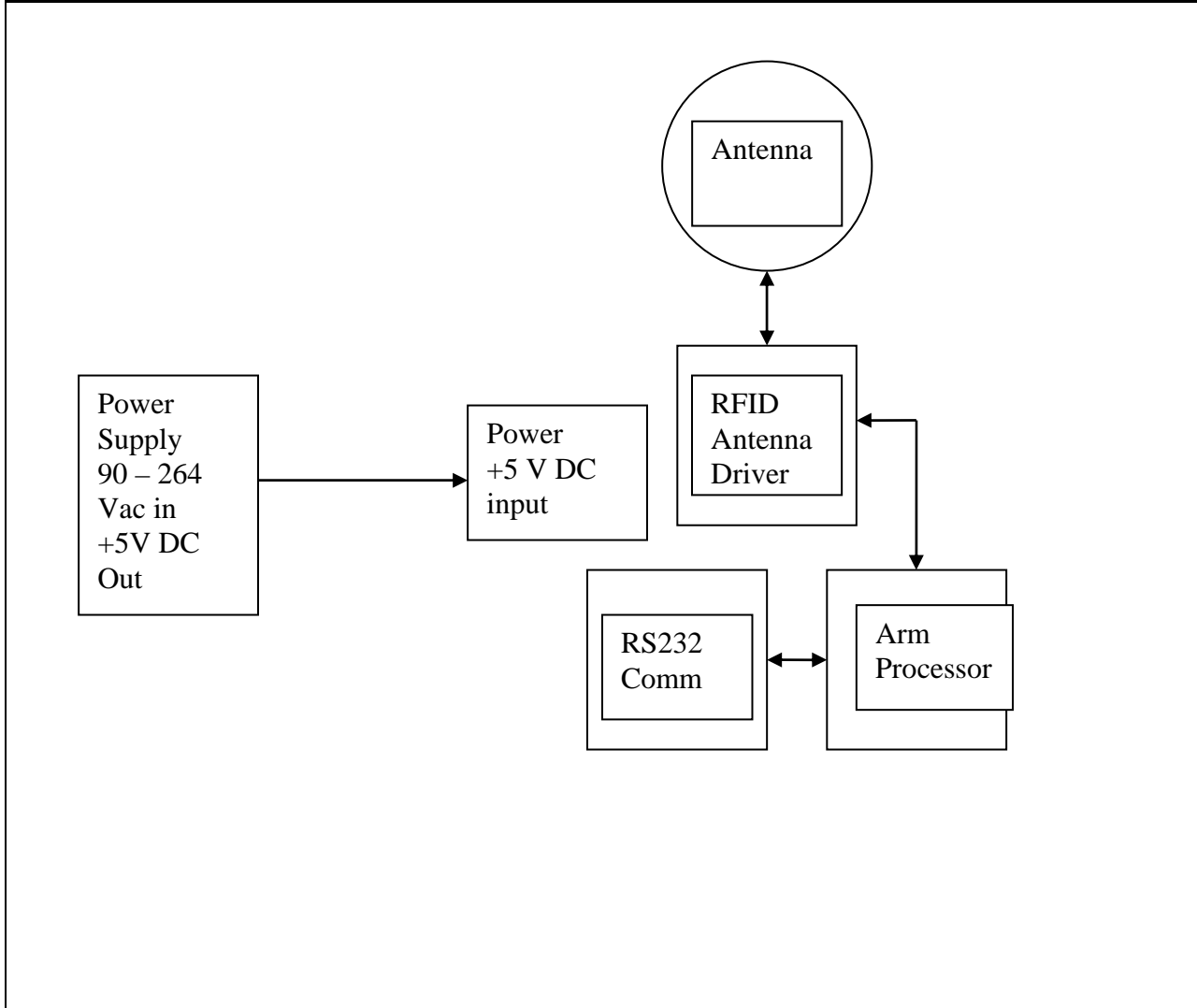

Authorization Signatures

Customer authorization to perform tests according to this test plan.

Dale Hallstrom

Test Plan/CDF Prepared By (please print)

Date

4/19/2010

Date