

FCC TEST REPORT

FCC ID : GCDAYC-G60
Applicant : Rosslare Enterprises Ltd
Address : Flat 12,9/F., Wing Fat Ind. Bldg.,12 Wang Tai Road , Kowloon Bay,
Kowloon, Hong Kong

Equipment Under Test (EUT) :

Product Name : Convertible Reader and Controller
Model No. : AYC-G60

Standards : FCC CFR47 Part 15 Section 15.209:2010

Date of Test : February 27 ~ March 6, 2012

Date of Issue : March 13, 2012

Test Engineer : Hunk yan / Engineer



Reviewed By : Philo zhong / Manager



Test Result	: PASS
--------------------	---------------

Prepared By:

Waltek Services (Shenzhen) Co., Ltd.

1/F, Fukangtai Building, West Baima Rd., Songgang Street, Baoan District,
Shenzhen 518105, China

Tel :+86-755-27553488

Fax:+86-755-27553868

✧ The sample detailed above has been tested to the requirements of Council Directives ANSI C63.4:2003. The test results have been reviewed against the Directives above and found to meet their essential requirements.

The results shown in this test report refer only to the sample(s) tested , This Test report cannot be reproduced, except in full, without prior written permission of the Company.

2 Test Summary

Test Items	Test Requirement	Test Method	Result
Radiated Emissions (9kHz ~ 1GHz)	Part 15.209	ANSI C63.4: 2003	PASS
Conducted Emissions (150kHz ~ 30MHz)	Part 15.207	ANSI C63.4:2003	N/A

The results shown in this test report refer only to the sample(s) tested , This Test report cannot be reproduced, except in full, without prior written permission of the Company.

3 Contents

	Page
1 COVER PAGE.....	1
2 TEST SUMMARY	2
3 CONTENTS.....	3
4 GENERAL INFORMATION	4
4.1 CLIENT INFORMATION.....	4
4.2 GENERAL DESCRIPTION OF E.U.T.....	4
4.3 DETAILS OF E.U.T.....	4
4.4 DESCRIPTION OF SUPPORT UNITS.....	4
4.5 STANDARDS APPLICABLE FOR TESTING	4
4.6 TEST FACILITY	5
4.7 TEST LOCATION	5
5 EQUIPMENT USED DURING TEST.....	6
6 CONDUCTED EMISSIONS.....	7
6.1 E.U.T. OPERATION.....	7
6.2 EUT SETUP.....	8
6.3 CONDUCTED EMISSION TEST RESULT	8
7 RADIATED EMISSIONS.....	9
7.1 MEASUREMENT UNCERTAINTY	10
7.2 EUT SETUP.....	10
7.3 SPECTRUM ANALYZER SETUP	11
7.4 TEST PROCEDURE.....	11
7.5 RADIATED EMISSIONS TEST RESULT	12
7.6 SUMMARY OF TEST RESULTS	12
7.7 PHOTOGRAPH – RADIATION EMISSION TEST SETUP	15
8 PHOTOGRAPHS - CONSTRUCTIONAL DETAILS.....	16
8.1 EUT – APPEARANCE VIEW	16
8.2 EUT – OPEN VIEW	17
8.3 PCB1 – VIEW.....	18
8.4 PCB2 – VIEW.....	19
9 FCC LABEL.....	20

The results shown in this test report refer only to the sample(s) tested , This Test report cannot be reproduced, except in full, without prior written permission of the Company.

4 General Information

4.1 Client Information

Applicant : Rosslare Enterprises Ltd
Address of Applicant : Flat 12,9/F., Wing Fat Ind. Bldg.,12 Wang Tai Road , Kowloon Bay, Kowloon, Hong Kong

Manufacturer : Rosslare Electronics(Shenzhen) Co., Ltd.
Address of Manufacturer : Block 2, No.A-1 Baiwangxin Industrial Park, Xili Town, Shenzhen, China

4.2 General Description of E.U.T.

Product Name : Convertible Reader and Controller
Model No. : AYC-G60
Operation Frequency : 125kHz

4.3 Details of E.U.T.

Technical Data: : DC 5V ~ 16V (Typical:12V)

4.4 Description of Support Units

The EUT is a Convertible Reader and Controller. It can function as a reader or as a controller. While connected to a controller and functioning as a reader, it transmits a 125kHz signal. In this report, the EUT was connected to the AC525 controller as a reader, and the power supplied by AC525 is DC 12.0V.

4.5 Standards Applicable for Testing

The customer requested FCC tests for a Convertible Reader and Controller. The standards used were FCC CFR47 Part 15 Section 15.207:2010 and Section 15.209:2010.

4.6 Test Facility

The test facility has a test site registered with the following organizations:

- **IC – Registration No.: IC7760A**

Waltek Services(Shenzhen) Co., Ltd. has been registered and fully described in a report filed with the Industry Canada. The acceptance letter from the Industry Canada is maintained in our files. Registration 7760A, August 3, 2010.

- **FCC – Registration No.: 880581**

Waltek Services(Shenzhen) Co., Ltd. EMC Laboratory has been registered and fully described in a report filed with the (FCC) Federal Communications Commission. The acceptance letter from the FCC is maintained in our files. Registration 880581, May 26, 2011.

4.7 Test Location

All the tests were performed at:

Waltek Services(Shenzhen) Co., Ltd. at 1/F, Fukangtai Building, West Baima Rd., Songgang Street, Baoan District, Shenzhen, China

5 Equipment Used during Test

Equipment Name	Manufacturer Model	Equipment No	Internal No	Specification	Cal. Date	Due Date	Uncertainty
EMC Analyzer	Agilent/ E7405A	MY451149 43	W2008001	9k-26.5GHz	Aug. 2, 2011	Aug. 1, 2012	±1dB
Trilog Broadband Antenne	SCHWARZB ECK MESS- ELEKTROM / VULB9163	336	W2008002	30-3000 MHz	Aug. 2, 2011	Aug. 1, 2012	±1dB
Broad-band Horn Antenna	SCHWARZB ECK MESS- ELEKTROM / BBHA 9120D(1201)	667	W2008003	1-18GHz	Aug. 2, 2011	Aug. 1, 2012	f < 10 GHz : ±1dB 10GHz < f < 18 GHz : ±1.5dB
Broadband Preamplifier	SCHWARZB ECK MESS- ELEKTROM / BBV 9718	9718-148	W2008004	0.5-18GHz	Aug. 2, 2011	Aug. 1, 2012	±1.2dB
10m Coaxial Cable with N-male Connectors	SCHWARZB ECK MESS- ELEKTROM / AK 9515 H	-	-	-	Aug. 2, 2011	Aug. 1, 2012	-
10m 50 Ohm Coaxial Cable	SCHWARZB ECK MESS- ELEKTROM / AK 9513	-	-	-	Aug. 2, 2011	Aug. 1, 2012	-
Positioning Controller	C&C LAB/ CC-C-IF	-	-	-	Aug. 2, 2011	Aug. 1, 2012	-
Color Monitor	SUNSP0/ SP-14C	-	-	-	Aug. 2, 2011	Aug. 1, 2012	-
Test Receiver	ROHDE&SC HWARZ/ ESPI	101155	W2005001	9k-3GHz	Aug. 2, 2011	Aug. 1, 2012	±1dB
Two-Line V-Network	ROHDE&SC HWARZ/ ENV216	100115	W2005002	50Ω/50μH	Aug. 2, 2011	Aug. 1, 2012	±10%
RF Generator	TESEQ GmbH/ NSG4070	25781	W2008008	Fraq-range : 9K-1GHz RF voltage : - 60 dBm- +10dBm	Aug. 2, 2011	Aug. 1, 2012	Power_freq distinguish0. 1Hz RFelectricity distinguish 0.1B
Active Loop Antenna	Beijing Dazhi / ZN30900A	-	-	9kHz- 30MHz	Aug. 2, 2011	Aug. 1, 2012	±1dB

The results shown in this test report refer only to the sample(s) tested , This Test report cannot be reproduced, except in full, without prior written permission of the Company.

6 Conducted Emissions

Test Requirement:	FCC CFR47 Part 15 Section 15.207
Test Method:	ANSI C63.4:2003
Test Result:	N/A
Frequency Range:	150kHz to 30MHz
Class:	Class B
Limit:	66-56 dB μ V between 0.15MHz & 0.5MHz 56 dB μ V between 0.5MHz & 5MHz 60 dB μ V between 5MHz & 30MHz
Detector:	Peak for pre-scan (9kHz Resolution Bandwidth) Quasi-Peak & Average if maximised peak within 6dB of Average Limit

6.1 E.U.T. Operation

Operating Environment:

Temperature: 25.5 °C

Humidity: 51 % RH

Atmospheric Pressure: 1012 mbar

EUT Operation:

The EUT was tested according to ANSI C63.4:2003. The frequency spectrum from 150kHz to 30MHz was investigated.

The maximised peak emissions from the EUT was scanned and measured for both the Live and Neutral Lines. Quasi-peak & average measurements were performed if peak emissions were within 6dB of the average limit line.

6.2 EUT Setup

The conducted emission tests were performed using the setup accordance with the ANSI C63.4:2003, The specification used in this report was the FCC Part15 Section 15.207 limits.

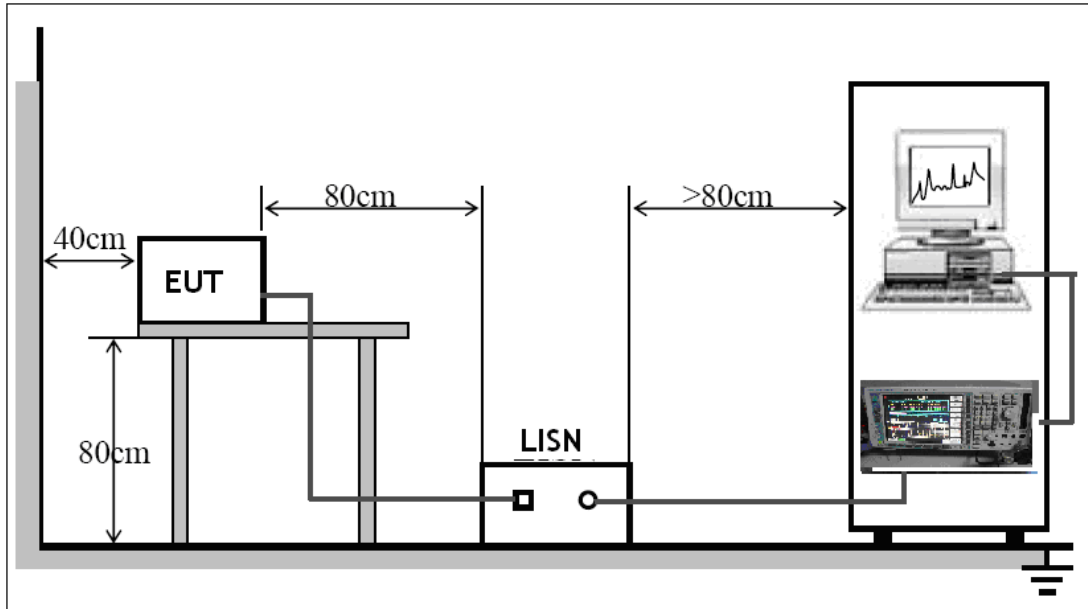

The EUT was placed on the test table in shielding room

6.3 Conducted Emission Test Result

This test is not applicable since the EUT is powered by DC 12V.

7 Radiated Emissions

Test Requirement: FCC CFR47 Part 15 Section 15.209
 Test Method: ANSI C63.4:2003
 Test Result: PASS
 Frequency Range: 9kHz to 1GHz
 Measurement Distance: 3m
 Limit:

Frequency (MHz)	Field Strength		Field Strength Limit at 3m Measurement Dist	
	uV/m	Distance (m)	uV/m	dBuV/m
0.009 ~ 0.490	2400/F(kHz)	300	10000 * 2400/F(kHz)	$20\log^{(2400/F(kHz))} + 80$
0.490 ~ 1.705	24000/F(kHz)	30	100 * 24000/F(kHz)	$20\log^{(24000/F(kHz))} + 40$
1.705 ~ 30	30	30	100 * 30	$20\log^{(30)} + 40$
30 ~ 88	100	3	100	$20\log^{(100)}$
88 ~ 216	150	3	150	$20\log^{(150)}$
216 ~ 960	200	3	200	$20\log^{(200)}$
Above 960	500	3	500	$20\log^{(500)}$

Note:

- a) The tighter limit applies at the band edges.
 For example: F.S limit at 88MHz is 100uV/m
- b) If measurement is made at 3m distance, then F.S Limit at 3m distance is adjusted by using the formula of $L_{d1} = L_{d2} * (d2/d1)^2$.
 For example:
 F.S Limit at 30m(d2) distance is 30uV/m(L_{d2}), then F.S Limit at 3m(d1) distance is
 $L_{d1} = 30\text{uV/m} * (30/3)^2 = 100 * 30\text{uV/m} = 69.54 \text{ dBuV/m}$

EUT Operation :

Operating Environment:

Temperature: 25.5 °C
 Humidity: 51 % RH
 Atmospheric Pressure: 1012 mbar

EUT Operation:

The EUT was tested in continuously transmit mode.

7.1 Measurement Uncertainty

All measurements involve certain levels of uncertainties, especially in the field of EMC. The factors contributing to uncertainties are spectrum analyzer, cable loss, antenna factor calibration, antenna directivity, antenna factor variation with height, antenna phase center variation, antenna factor frequency interpolation, measurement distance variation, site imperfections, mismatch (average), and system repeatability.

Based on NIS 81, The Treatment of Uncertainty in EMC Measurements, the best estimate of the uncertainty of a radiation emissions measurement at Waltek EMC Lab is $\pm 5.03\text{dB}$.

7.2 EUT Setup

The radiated emission tests were performed in the 3m Semi- Anechoic Chamber test site, using the setup accordance with the ANSI C63.4:2003.

a) Radiated Emission Test Setup, Frequency Below 30MHz

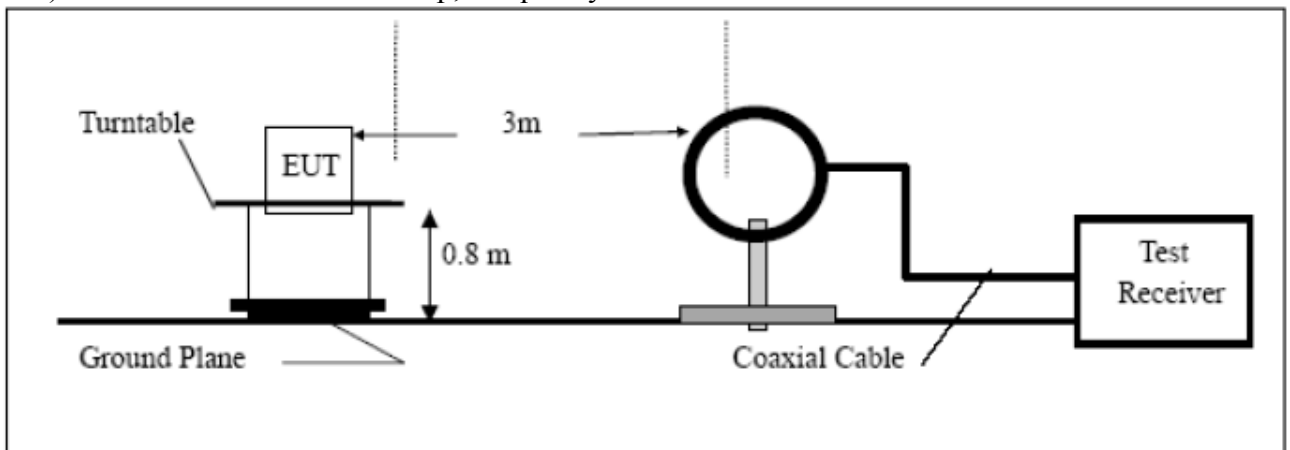

b) Radiated Emission Test Setup, Frequency range 30MHz ~ 1000MHz

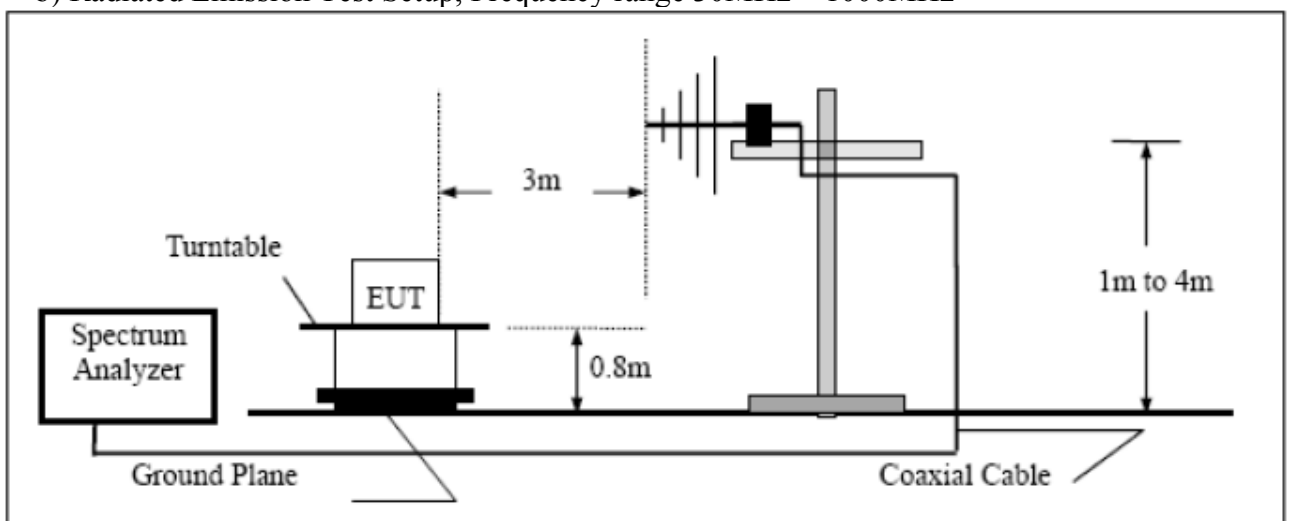

The results shown in this test report refer only to the sample(s) tested, This Test report cannot be reproduced, except in full, without prior written permission of the Company.

7.3 Spectrum Analyzer Setup

According to FCC Part15 Rules, the system was tested 9kHz to 1000MHz.

Below 30MHz

Start Frequency 9 kHz
 Stop Frequency 30MHz
 Sweep Speed Auto
 IF Bandwidth 10 KHz
 Video Bandwidth 10KHz
 Resolution Bandwidth 10KHz

Above 30MHz

Start Frequency 30MHz
 Stop Frequency 1000MHz
 Sweep Speed Auto
 IF Bandwidth 120 KHz
 Video Bandwidth 100KHz
 Quasi-Peak Adapter Bandwidth 120 KHz
 Quasi-Peak Adapter Mode Normal
 Resolution Bandwidth 120kHz

7.4 Test Procedure

a) Test Procedure (below 30MHz)

1. The EUT is placed on a turntable, which is 0.8m above ground plane.
2. The turntable shall be rotated for 360 degrees to determine the position of maximum emission level.
3. EUT is set 3m away from the receiving antenna.
4. Maximum procedure was performed on the six highest emissions to ensure EUT compliance.
5. Repeat above procedures until the measurements for all frequencies are complete.

b) Test Procedure (above 30MHz)

1. The EUT is placed on a turntable, which is 0.8m above ground plane.
2. The turntable shall be rotated for 360 degrees to determine the position of maximum emission level.
3. EUT is set 3m away from the receiving antenna, which is moved from 1m to 4m to find out the maximum emissions.
4. Maximum procedure was performed on the six highest emissions to ensure EUT compliance.
5. And also, each emission was to be maximized by changing the polarization of receiving antenna both horizontal and vertical.
6. Repeat above procedures until the measurements for all frequencies are complete.
7. The radiation measurements are performed in X(normal uses) axis positioning. And all the modes was tested in the report. Only the worst case is shown in the report.

7.5 Radiated Emissions Test Result

Formula of conversion factors:the field strength at 3m was established by adding the meter reading of the spectrum analyzer (which is set to read in units of dBuV/m) to the antenna correction factor supplied by the antenna manufacturer. The antenna correction factors are stated in terms of dB. The gain of the pressletor was accounted for in the spectrum analyser meter reading.

Example:

Freq(MHz) Meter Reading +ACF=FS

33 20dBuV+10.36dB=30.36dBuV/m @3m

7.6 Summary of Test Results

According to the data in this section, the EUT complied with the FCC Part15 C standards.

Test Data below 30MHz

Frequency (kHz)	Detector	Level (dBuV/m)	Limit (dBuV/m)	Margin (dB)	Measurement Distance (m)
125	AV	74.85	105.67	-30.82	3
No suspicious signal found in other frequency.					

Test Data above 30MHz

Antenna Polarization: Vertical

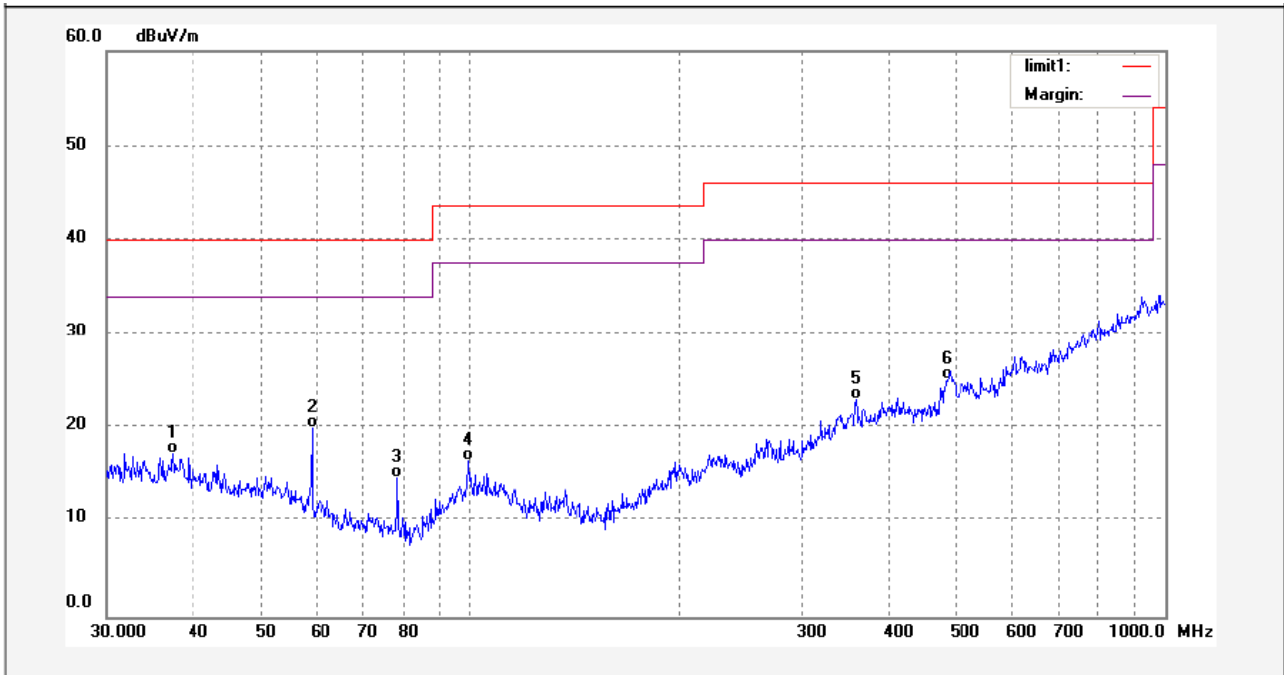

No.	Freq. (MHz)	Reading (dBuV/m)	Factor (dB)	Result (dBuV/m)	Limit (dBuV/m)	Margin (dB)	Detector	Remark
1	37.3017	0.73	16.56	17.29	40.00	-22.71	QP	
2	59.1052	7.31	12.72	20.03	40.00	-19.97	QP	
3	78.5645	5.65	9.16	14.81	40.00	-25.19	QP	
4	99.4177	2.63	13.89	16.52	43.50	-26.98	QP	
5	359.7114	2.27	20.76	23.03	46.00	-22.97	QP	
6	484.9068	0.89	24.20	25.09	46.00	-20.91	QP	

The results shown in this test report refer only to the sample(s) tested , This Test report cannot be reproduced, except in full, without prior written permission of the Company.

Antenna Polarization: Horizontal

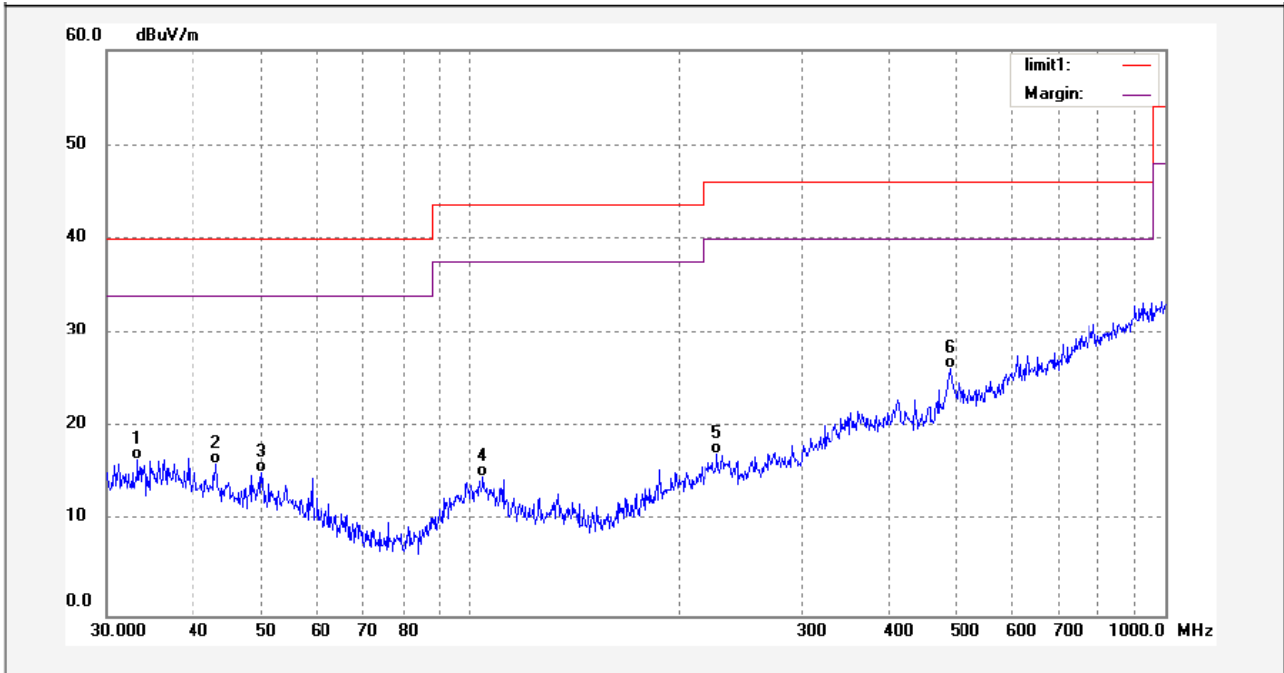

No.	Freq. (MHz)	Reading (dBuV/m)	Factor (dB)	Result (dBuV/m)	Limit (dBuV/m)	Margin (dB)	Detector	Remark
1	33.2180	-0.04	16.56	16.52	40.00	-23.48	QP	
2	43.0816	0.83	15.26	16.09	40.00	-23.91	QP	
3	50.1080	0.62	14.57	15.19	40.00	-24.81	QP	
4	104.4303	0.51	14.23	14.74	43.50	-28.76	QP	
5	227.0164	0.94	16.29	17.23	46.00	-28.77	QP	
6	490.0451	0.50	25.75	26.25	46.00	-19.75	QP	

The results shown in this test report refer only to the sample(s) tested , This Test report cannot be reproduced, except in full, without prior written permission of the Company.

7.7 Photograph – Radiation Emission Test Setup

Below 30MHz



Above 30MHz

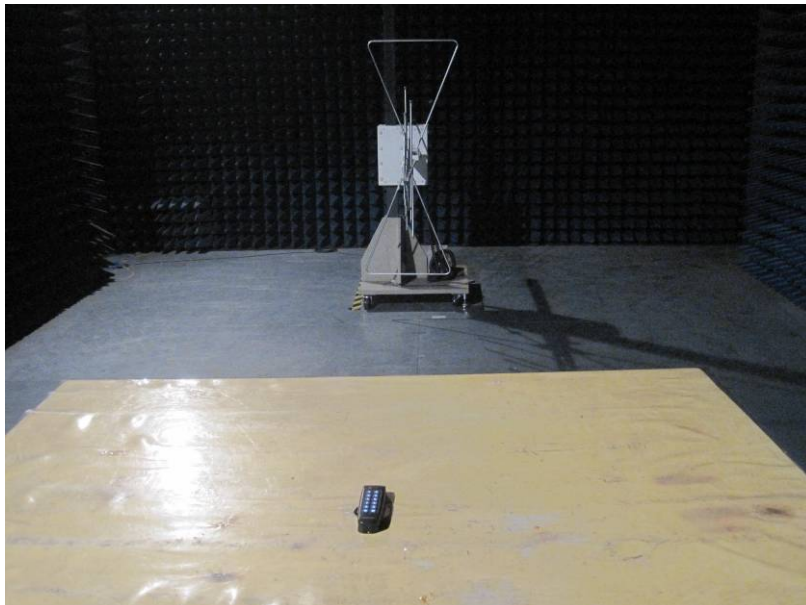

The results shown in this test report refer only to the sample(s) tested , This Test report cannot be reproduced, except in full, without prior written permission of the Company.

WALTEK SERVICES

Reference No.: WT12021097-S-S-F

8 Photographs - Constructional Details

8.1 EUT – Appearance View



The results shown in this test report refer only to the sample(s) tested , This Test report cannot be reproduced, except in full, without prior written permission of the Company.

8.2 EUT – Open View



8.3 PCB1 – View

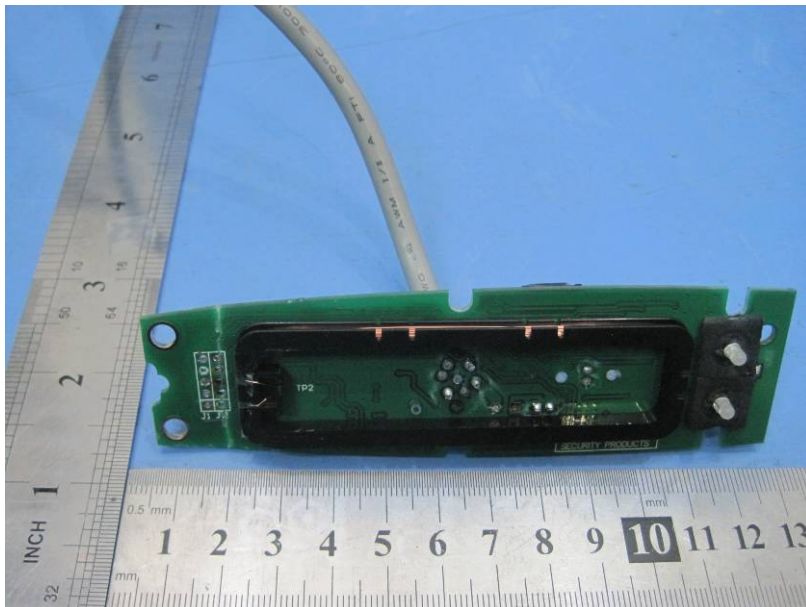
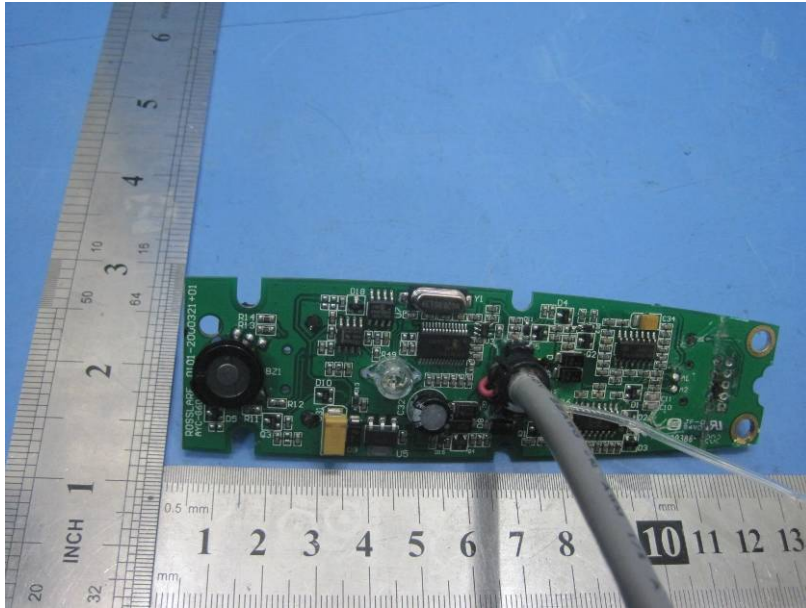

8.4 PCB2 – View

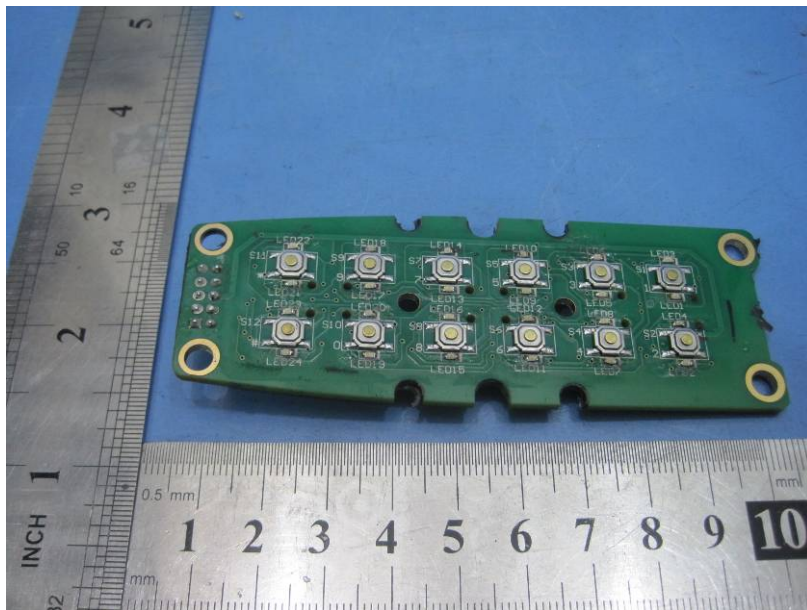
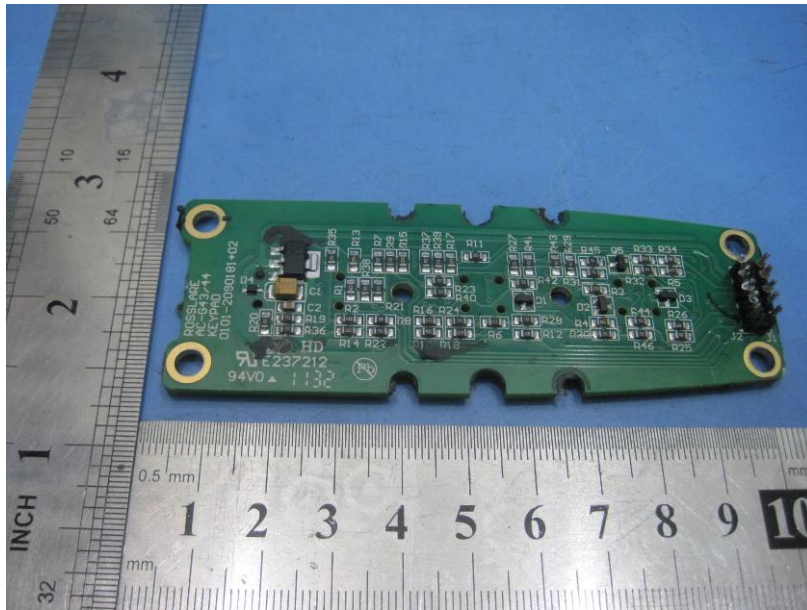

9 FCC Label

This device complies with Part 15 of the FCC Rules. Operation is subject to the following two conditions:(1)this device may not cause harmful interference,and (2) this device must accept any interference received, including interference that may cause undesired operation

The Label must not be a stick-on paper. The Label on these products must be permanently affixed to the product and readily visible at the time of purchase and must last the expected lifetime of the equipment not be readily detachable.

Proposed Label Location on EUT
EUT Bottom View/proposed FCC Label Location



The results shown in this test report refer only to the sample(s) tested , This Test report cannot be reproduced, except in full, without prior written permission of the Company.