

AYCx60 serial Block Diagram and Operation Description:

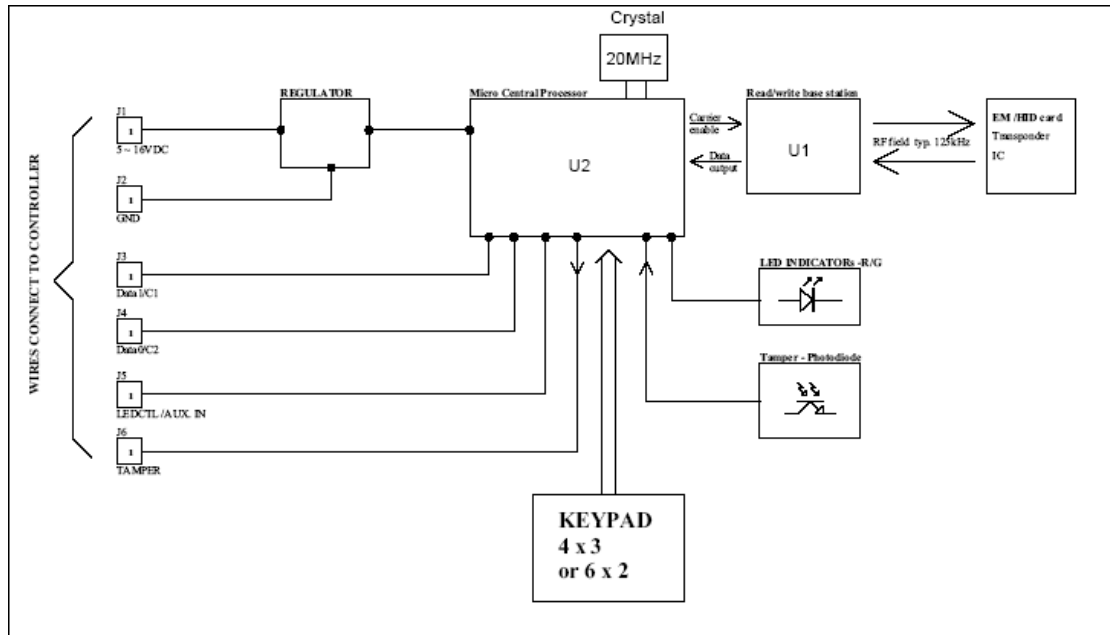

After power on, the AYC-x60 reader sends a 125KHz RF signal to ambient environment, when the HID/EM card reach the magic field, an induction signal will be received by U1 that is located on the AYC-x60 board, then U1 transfers the data to U2, the LED turns green when U2 receives this data along with a long sound “DU” emitted by the buzzer, after that U2 outputs a 26bit Wiegand data.. AYC-x60 has the additional function that when the photosensitive sensor located on the back cover of the reader is activated by a strengthened light, the sensor will generate a signal and transfer it to U2 for processing, then a processed data will be sent to the siren for tamper alert. The keypad on the AYC-x60 works as an input device and can be used to set password and configure the reader.