

REV	Δ	Description	Sheet Effected	Date	Drawn	Checked
A				25/01/2009	M. Reuben	S.Cohen
B		Replaced 15.109 with 15.209	13, 23-27	28/07/2009	M. Reuben	S.Cohen

EMC Laboratory

SA-80G

FCCID: GCD-SA-80G
Manufactured by
ROSSLARE Enterprises LTD.

Test Report
According to FCC Part 15 Requirements

January 2009



	Function/Title	Name	Signature	Date
Prepared by	Technical Writer	M. Reuben		28/07/2009
Checked by	Test Engineer	I. Arbitman		28/07/2009
Approved by	EMC Lab. Manager	S.Cohen		

Table of Contents

Para	Page
1 INTRODUCTION	4
2 TEST SUMMARY AND SIGNATURES.	5
3 E.U.T INFORMATION	6
4 BANDWIDTH OF THE EMISSION PART 15.231—TEST RESULTS	7
5 FIELD STRENGTH OF FUNDAMENTAL PART 15.231-TEST RESULTS.....	8
6 RADIATED EMISSION PART 15.231 & 15.205-TEST RESULTS	9
7 RADIATED EMISSION PART 15.209-TEST RESULTS.....	12
8 POWER LINE CONDUCTED INTERFERENCE PART 15.207-TEST RESULTS.....	14
9 PLOTS	15
10 CORRECTION FACTORS	34
11 ABBREVIATIONS AND ACRONYMS	36
12 PHOTOGRAPHS	37

List of Figures

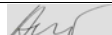
Para	Page
Figure 1: Test Configuration	6
Figure 2: Radiated Emission Set up	11
Figure 3: Radiated Emission test 10 KHz – 30 MHz	11
Figure 4: Radiated Emission test 30 MHz – 1 GHz	11
Figure 5: Radiated Emission test above 1 GHz.....	11
Plot 1.....	15
Test Results Plot No 2.....	16
Test Results Plot No 3.....	17
Test Results Plot No 4.....	18
Test Results Plot No 5.....	19
Test Results Plot No 6.....	20
Test Results Plot No 7.....	21
Test Results Plot No 8.....	22
Test Results Plot No 9.....	23
Test Results Plot No 10.....	24
Test Results Plot No 11.....	25
Test Results Plot No 12.....	26
Test Results Plot No 13.....	27
Test Results Plot No 14.....	28
Test Results Plot No 15.....	29
Test Results Plot No 16.....	30
Test Results Plot No 17.....	31
Transmission time	31
Test Results Plot No 18.....	31
Repetitive transmission time	31
Test Results Plot No 19.....	32
Test Results Plot No 20.....	32
Test Results Plot No 21.....	33

Test Results Plot No 22	33
20log13.44/100=-17.43	33

List of Tables

Para	Page
Table 4.b: Limits for Bandwidth	7
Table 4.c: Test Instrumentation and Equipment.....	7
Table 4.d: Bandwidth Test Result	7
Table 5.b: Limits for Fundamental	8
Table 5.c: Test Instrumentation and Equipment.....	8
Table 5.d: Average Factor	8
Table 5.d.1: Peak Result of Fundamental	8
Table 5.d.2: Average Result of Fundamental	8
Table 6.b: Limits for 15.231(b)	9
Table 6.c: Test Instrumentation and Equipment.....	9
Table 6.d: Preliminary Test Results for intentional Emissions in TX Mode 15.231.....	9
Table 6.e: Six Highest Peak Emission Test Results	10
Table 6.e1: Six Highest Average Emission Test Results	10
Table 7.c: Limits for 15.209 Class B equipment	12
Table 7.d: Test Instrumentation and Equipment	12
Table 7.e: Preliminary Test Results for Unintentional Emissions in RX Mode 15.209	13
Table 7.f: Six Highest RX Mode 15.209	13
Table 8c: Limits for 15.207 Class B equipment.....	14
Table 8.d: Test Instrumentation and Equipment	14
Table 6.d: Test Results for Conducted Interference Part 15.207.....	14

1 INTRODUCTION

a. Scope

This document describes the measurement procedures and tests for FCC part 15 of the SA-80G Manufactured by Rosslare Ltd.

b. Description of equipment Under Test.

Equipment Under Test:	SA-80G
FCCID	GCD-SA-80G
Manufacturer:	Rosslare Ltd.
Serial Numbers:	0825-433A0
Mode of Operation:	TX MODE
Receiver operating frequency:	433.92 MHZ
Year of Manufacture:	2008

c. Applicant Information:

Applicant:	Rosslare Ltd.
Applicant Address	Suite 912 Wing Fat Industrial Building, 12 Wang Tai Road, Kowloon Bay, Hong- Kong
Telephone:	+972-3-9386838
FAX:	+972-3-9386830
The testing was observed by:	ALLAN GREEN
Following applicant's personnel:	ALLAN GREEN

d. Test Performance:

Date of reception for testing:	15/01/2009
Dates of testing	15/01/2009 – 25/01.2009
Test Laboratory Location	Elbit Systems Land and C ⁴ I – Tadiran Ltd., EMC LAB, Hashoftim 26 Holon 58102 ISRAEL Tel: 972-3-5574476 Fax: 972-3-5575320
Applicable EMC Specification:	
Code of Federal Regulations	47, FCC Docket 89-103, Part 15: Radio Frequency Devices, Sections 15.209, 15.231, 15.205 & 15.207



2

TEST SUMMARY AND SIGNATURES.

Elbit Systems Land and C⁴I – Tadiran Ltd., EMC Laboratory has completed testing of E.U.T in accordance with the requirements of the FCC Part 15 Regulations for Class B equipment.

The E.U.T was found to comply with the requirements of the FCC Part 15 Regulations given below

Test	Test Description	Section	PASS/FAIL
1	Bandwidth of the emission	15.231	PASS
2	Field strength of fundamental	15.231	PASS
3	Radiation emission	15.209	PASS
4	Radiation emission	15.231 & 15.205	PASS
5	Power Line Conducted Interference	15.207	PASS

	Function/Title	Name	Signature	Date
Test performed by	Test Engineer	I. Arbitman		25/01/2009
Test Report prepared by	Technical Writer	M. Reuben		25/01/2009
Test Report Approved by	EMC Lab. Manager	S Cohen		03/02/2009

3 E.U.T INFORMATION

a. E.U.T description

- (1) Station for Rosslare's SecuraCare Wireless Intrusion system. The SA-80G includes a transceiver that works on 433.92 or 868.35 MHz, depending on the device model. The device receives supervisory signals from the SecuraCare wireless devices during an intrusion event, or a supervisory period (between 20-60 min, depending on model). The SA-80G sends and receives ACK signals to the SA-80 Wireless siren during normal operation. The range of the devices from the SA-80G is a maximum of 300 meters, in line of sight. The SA-80G also acts as a telephone, with full features and recognition of standard dial tone. In an event of an emergency, the SA-80G will dial out to system programmed numbers, with a recorded message. The SA-80G also allows the user to dial into the phone via PSTN and configure the system, or listen-in (half-duplex)

b. E.U.T Test Configuration

E.U.T. test configuration is shown in figure bellow

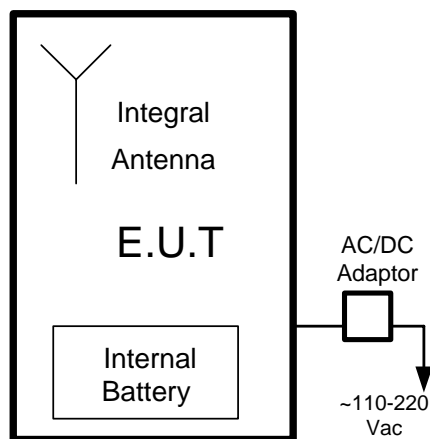

Figure 1: Test Configuration

c. E.U.T Mode of Operation description

- (1) 433.92MHz TX Mode

4 BANDWIDTH OF THE EMISSION PART 15.231—TEST RESULTS

E.U.T: SA-80G
 S/N: 0825-433A0
 Test Method: ANSI 63.4
 Date: 22/01/2009
 Relative Humidity: 29%
 Ambient Temperature: 21c
 Air Pressure: 1053hpa
 Test Setup: Figure 1

Testing Engineer: I. Arbitman 

Date 22/01/2009

a. Test Results Summary & Conclusions

The E.U.T was found in compliance with Bandwidth of Radiated Emission fundamental frequency requirement

b. Limits of bandwidth

The test unit shall meet the limits of Table 4.b

Table 4.b: Limits for Bandwidth

Frequency (MHz)	Bandwidth Max Limits (%)	Bandwidth Max Limits (KHz)
433.92	0.25	1085

c. Test Instrumentation and Equipment

Table 4.c: Test Instrumentation and Equipment

Item	Model	Manufacturer	Next Date Calibration
Spectrum Analyzer	8593E	HP	20.05.09
Broadband Antenna	BTA-L	FRANKONIA	15.05.09

d. Test Results

Table 4.d: Bandwidth Test Result

Frequency (MHz)	Bandwidth (KHz)	Bandwidth Max Limit(KHz)	Plot No	PASS/FAIL
433.9238	61.25	1085	1	PASS

e. Procedure

The Bandwidth is determined at the point 20db down from the modulated carrier, while the spectrum analyzer was set to “max hold” and R.B.W – 10 KHz.

5 FIELD STRENGTH OF FUNDAMENTAL PART 15.231-TEST RESULTS

E.U.T SA-80G
 S/N: 0825-433A0
 Test Method: ANSI 63.4
 Date: 21/01/2009
 Relative Humidity: 29%
 Ambient Temperature: 20c
 Air Pressure: 1053hpa
 Test Setup: Figure 1

Testing Engineer: I. Arbitman 

Date 21/01/2009

a. Test Results Summary & Conclusions

The E.U.T was found in compliance with fundamental frequency requirement

b. Limits of Field Strength for fundamental according 15.231

The test unit shall meet the limits of Table 5.b.

Table 5.b: Limits for Fundamental

Frequency (MHz)	Average Max Limits (dB μ V/m)	Peak Max Limits (dB μ V/m)
433.916	81	100

c. Test Instrumentation and Equipment

Table 5.c: Test Instrumentation and Equipment

Item	Model	Manufacturer	Next Date Calibration
Spectrum Analyzer	8593E	HP	20.05.09
Broadband Antenna	BTA-L	FRANKONIA	15.05.09

d. Test Results

Table 5.d: Average Factor

TX Period(min)	Duty Cycle(min)	Average Factor(db)	Plot No
13.44ms	$13.44/100=0.13$	$20\log 0.134=-17.43$	17-22

Table 5.d.1: Peak Result of Fundamental

Frequency (MHz)	Peak Result (dB μ V/m)	peak Limits (dB μ V/m)	Margin (dB)	Test Results Plot No	Pass/ Fail
433.928	93.4	100	6.60	2	PASS

Table 5.d.2: Average Result of Fundamental

Peak Result (dB μ V/m)	Average Factor	Calculation Results	Average Limits (dB μ V/m)	Margin (dB)	Pass/ Fail
93.4	-17.43	75.97	81	5.03	PASS

e. Test Procedure

The EUT was placed on the top of rotating table 0.8 meters above the ground and the table was rotated 360°, the height of antenna is varied from one to 4 meters (vertical and horizontal polarization) to determine the max field strength of fundamental

6 RADIATED EMISSION PART 15.231 & 15.205-TEST RESULTS

E.U.T SA-80G
 S/N: 0825-433A0
 Test Method: ANSI 63.4
 Date: 22/01/2009
 Relative Humidity: 29%
 Ambient Temperature: 21c
 Air Pressure: 1053hpa
 Test Setup: Figure 1 to 4

Testing Engineer: I. Arbitman 

Date 22/01/2009

a. Test Results Summary & Conclusions

The E.U.T was found to be in compliance with 15.231

b. Limits of Radiated Interference Field Strength according 15.231

The test unit shall meet the limits of Table 6.b.

Table 6.b: Limits for 15.231(b)

Frequency range(MHz)	Average Limits (dB μ V/m)	peak Limits (dB μ V/m)
0.009 – 3500	61	81

c. Test Instrumentation and Equipment

Table 6.c: Test Instrumentation and Equipment

Item	Model	Manufacturer	Next Date Calibration
Spectrum Analyzer	8593E	HP	20/05/2009
Loop Antenna	HFH2-Z2	R&S	26/04/2011
Double Ridge Guide Antenna(1-18GHz)	DRG-118/A	ARA	09/12/2009
Broadband Antenna	BTA-L	FRANKONIA	15/05/2009
Low Noise Amplifier (0-1GHz)	AM-1300-N	MITEQ	09/04/2009
Low Noise Amplifier (1-4GHz)	AMM 003N	Avantek	11/06/2009
Low Noise Amplifier (2-18GHz)	PE 2-38	Planar	14/09/2009

d. Preliminary Test Results

Table 6.d: Preliminary Test Results for intentional Emissions in TX Mode 15.231

Antenna Polarization	Freq. Range MHz	Res. BW (kHz)	Test Results Plot No	PASS/FAIL
Both Hor.& Ver	0.009 – 0.15	0.2	3	PASS
	0.15 - 30	9	4	PASS
	30 - 1,000	120	5	PASS
	1,000 – 2,900	1000	6	PASS
	2,900 – 5,000	1000	7	PASS

e. Final Results

Table 6.e: Six Highest Peak Emission Test Results

Mode of Operation	Frequency (MHz)	Peak Reading (*) (dB μ V/m)	Limit dB μ V/m	Margin (dB)	Pass/Fail
TX	All peaks below 6 dB				PASS
					PASS

*Restricted bands

Table 6.e1: Six Highest Average Emission Test Results

Mode Of Operation	Frequency (MHz)	Calculated (dB μ V/m)	Limit dB μ V/m	Margin (dB)	Pass/Fail
TX	All peaks below 6 dB				PASS
					PASS

f. Test Procedure

(1) Preliminary Test Procedure

- a) The EUT was placed on the top of a rotating table 0.8 meters above the ground at a chamber shielded
- b) The E.U.T was set 3 meters away from the receiving antenna, which was mounted on the top of a variable-height antenna tower.
- c) The Antenna height varied from one meter above the ground over its full-allowed range of travel and the table was rotated 360° to determine the maximum value of the field strength
- d) The antenna was set both horizontal and vertical polarization.

(2) Final Test Procedure

- a) The EUT was tested at open area for each suspected emission
- b) The test procedure was performed according paragraph (1) and figure 11

g.

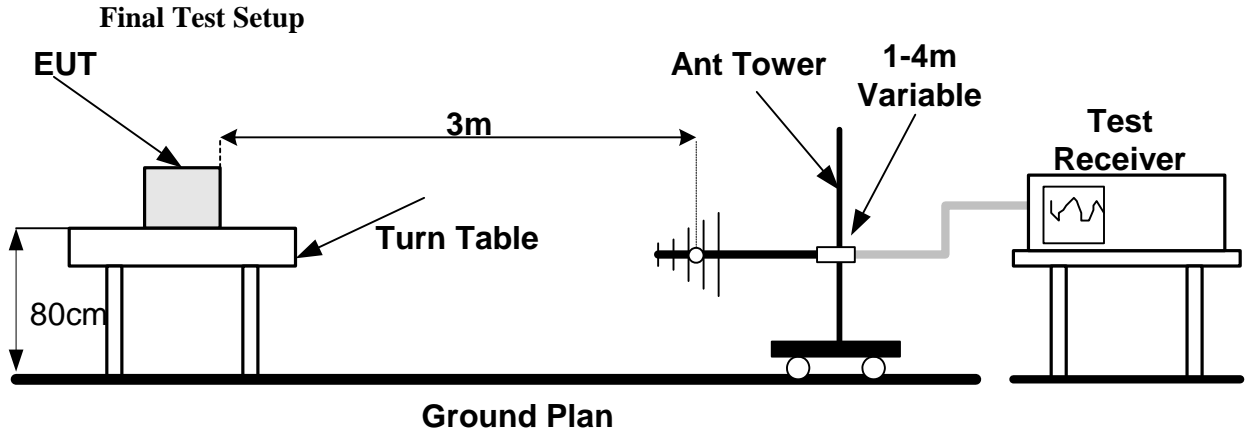

Figure 2: Radiated Emission Set up

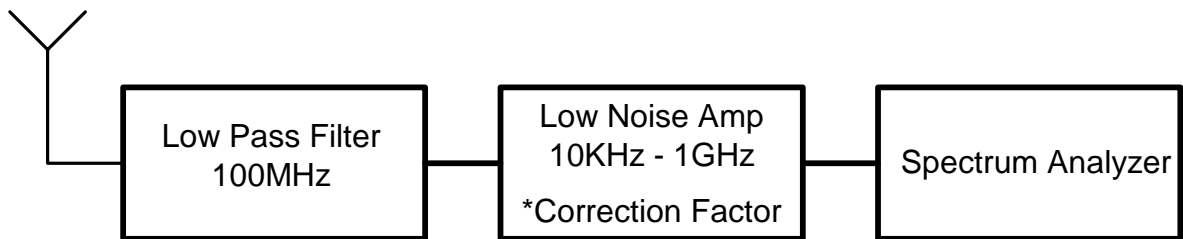

Figure 3: Radiated Emission test 10 KHz – 30 MHz

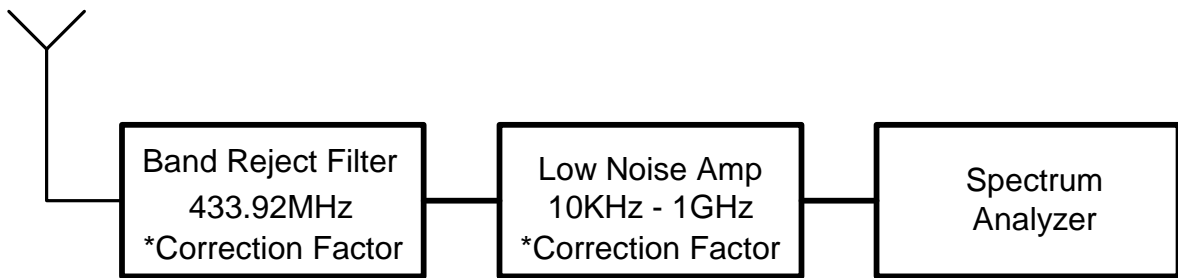

Figure 4: Radiated Emission test 30 MHz – 1 GHz

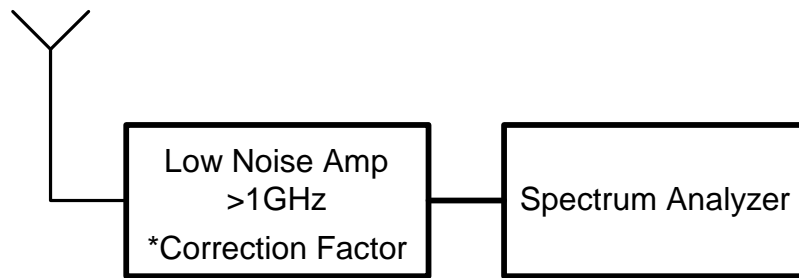

Figure 5: Radiated Emission test above 1 GHz

7 RADIATED EMISSION PART 15.209-TEST RESULTS

a. Preliminary Radiated emission Test Result According Part 15.209

E.U.T SA-80G
 S/N: 0825-433A0
 Test Method: ANSI 63.4
 Date: 23/07/2009
 Relative Humidity: 29%
 Ambient Temperature: 21c
 Air Pressure: 1053hpa
 Test Setup: Figure 1

Testing Engineer: I. Arbitman 

Date 23/07/2009

b. Test Results Summary & Conclusions

The E.U.T was found in compliance with 15.209

c. Limits of Radiated Interference Field Strength according 15.209

The test unit shall meet the limits of Table 7.c for Class B equipment.

Table 7.c: Limits for 15.209 Class B equipment

Frequency Range (MHz)	Field strength (microvolts/meter)	Measurement distances (meters)
0.009 – 0.490	2400/F (kHz)	300
0.490 – 1.705	2400/F (kHz)	30
1.705 – 30.0	30	30
30 - 88	100	3
88 – 216	150	3
216 – 960	200	3
Above 960	500	3

d. Test Instrumentation and Equipment

Table 7.d: Test Instrumentation and Equipment

Item	Model	Manufacturer	Next Date Calibration
Spectrum Analyzer	8593E	HP	24/06/2010
Loop Antenna	HFH2-Z2	R&S	26/04/2011
Double Ridge Guide Antenna(1-18GHz)	DRG-118/A	ARA	09/12/2009
Broadband Antenna	BTA-L	FRANKONIA	28/07/2010
Low Noise Amplifier (0-1GHz)	AM-1300-N	MITEQ	06/01/2010
Low Noise Amplifier (1-4GHz)	AMM 003N	Avantek	12/06/2010
Low Noise Amplifier (2-18GHz)	PE 2-38	Planar	14/09/2009

e. Preliminary Results

Table 7.e: Preliminary Test Results for Unintentional Emissions in RX Mode 15.209

Configuration	Antenna Polarization	Frequency Range MHz	Res. BW (kHz)	Test Results Plot No	PASS/FAIL
TX	Vertical	0.09-0.15	0.2	8	PASS
		0.15-30	9	9	PASS
	Both	30-1000	120	10	PASS
		1000-2900	1000	11	PASS
		2900-5000		12	PASS

f. Final Test Results

Table 7.f: Six Highest RX Mode 15.209

Nr	Frequency (MHz)	PK MaxHold (dB μ V/m)	QP Value (dB μ V/m)	PK Limit (dB μ V/m)	QP Limit (dB μ V/m)	Result	Angle (degrees)	Height (m)	H/V
1	867.853	44.5	44.2	46	46	Pass	0	1.8	V

g. Test Procedure
See paragraph 7.f

8 POWER LINE CONDUCTED INTERFERENCE PART 15.207-TEST RESULTS

a. Preliminary Radiated emission Test Result According Part 15.207

E.U.T SA-80G
 S/N: 0825-433A0
 Test Method: ANSI 63.4
 Date: 22/01/2009
 Relative Humidity: 29%
 Ambient Temperature: 21c
 Air Pressure: 1053hpa
 Test Setup: Figure 1

Testing Engineer: I. Arbitman 

Date 22/01/2009

b. Test Results Summary & Conclusions

The E.U.T was found in compliance with 15.207

c. Limits of Radiated Interference Field Strength according 15.207

The test unit shall meet the limits of Table 8c for Class B equipment.

Table 8c: Limits for 15.207 Class B equipment

Frequency (MHz)	Quasi Peak Limits (dB μ V)	Average Limits (dB μ V)
0.15 – 0.5	66 – 56	56 – 46
0.5 – 5.0	56	46
5.0 – 30	60	50

d. Test Instrumentation and Equipment

Table 8.d: Test Instrumentation and Equipment

Item	Model	Manufacturer	Next Date Calibration
Spectrum Analyzer	8593E	HP	20/05/2009
Double Ridge Guide Antenna(1-18GHz)	DRG-118/A	ARA	09/12/2009
Broadband Antenna(30-1000MHz)	BTA-L	FRANKONIA	15/05/2009
Low Noise Amplifier (0-1GHz)	AM-1300-N	MITEQ	09/04/2009
Low Noise Amplifier (1-4GHz)	AMM 003N	Avantek	11/06/2009
Low Noise Amplifier (2-18GHz)	PE 2-38	Planar	14/09/2009

e. Test Data

Table 6.d: Test Results for Conducted Interference Part 15.207

Tested Line	Freq. Range MHz	Res. BW (kHz)	Test Results Plot No	PASS/FAIL
Neutral	0.15 – 0.50	9	13	PASS
	0.50 - 30		14	PASS
Phase	0.15 – 0.50		15	PASS
	0.50 - 30		16	PASS

9 PLOTS

a. BANDWIDTH OF THE EMISSION part 15.231

SoftPlot Measurement Presentation

dBuV Trace A

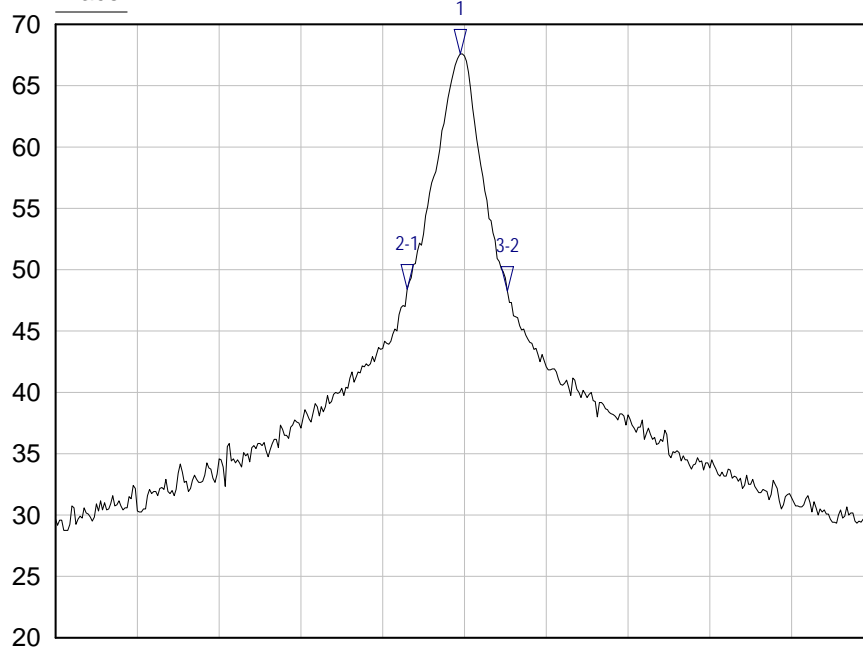

- 1 Trace A
▽ 433.9238 MHz
67.59 dBuV
- 2-1 Trace A
▽ -32.5000 kHz
-19.16 dB
- 3-2 Trace A
▽ 61.2500 kHz
-0.20 dB

Start: 433.6763 MHz

Stop: 434.1763 MHz

Res BW: 10 kHz

Vid BW: 1 MHz

Sweep: 6.92 ms

1/22/2009 1:50:23 PM

E7405A

Plot 1

b. Field strength of fundamental part 15.231

Test Results Plot No 2

FCC Fundamental 433.92MHz

Test & EUT General Information		Receiver Setting	
EUT Name:	SA-80G	Spect Analyzer	Hewlett Packard 7405 AC coupling
S/N:	6003990	Ref. Level:	100 dB μ V
Date of Test:	15/01/2009	RBW:	100 kHz
Test Engineer:	Ilya Arbitman	VBW:	1000 kHz
Antenna:	Frankonia BTA red -L_A 3m	Sweep Time:	Auto: 10 ms
Polarization:	Horizontal and Vertical	Pre Amplifier	No Description Available

TEST REMARKS: Thursday, January 15, 2009 11:27:10 AM
FIELD STRENGTH OF FUNDAMENTAL

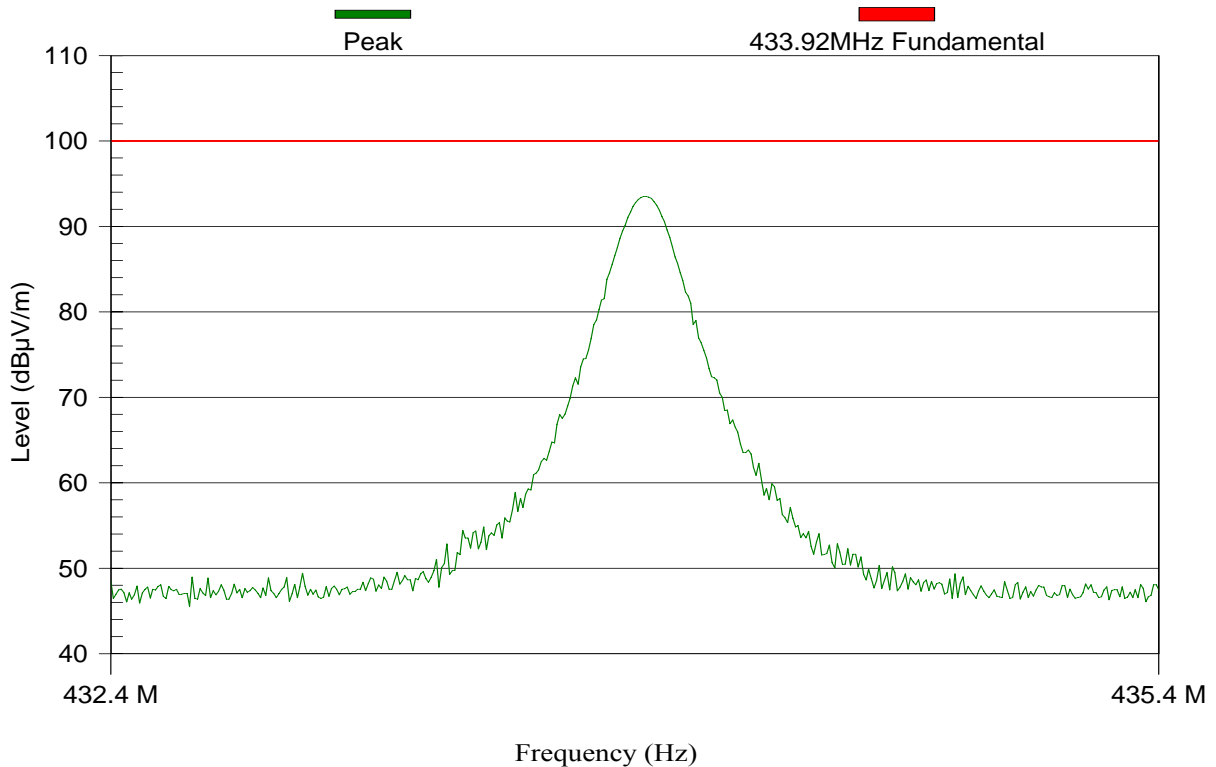

Frequency (MHz)	Pk
433.928	93.4

c. Radiated emission part 15.231 & 15.205

Test Results Plot No 3

RE FCC Class B 9-150 KHz

Test & EUT General Information		Receiver Setting	
EUT Name:	SA-80G	Spect Analyzer	Hewlett Packard 7405A DC Coupling
S/N:	6003990	Ref. Level:	110 dB μ V
Date of Test:	22/02/2009	RBW:	200 Hz
Test Engineer:	Ilya Arbitman	VBW:	300 Hz
Antenna:	LOOP ANT.HFH 2 Z2	Sweep Time:	Auto: 12.69 s
Polarization:	Vertical	Pre Amplifier	LNA MITEQ 0.01-1GHz No-1

TEST REMARKS: Thursday, January 22, 2009 11:00:30 AM
RADIATED EMISSION PART 15.231 & 15.205

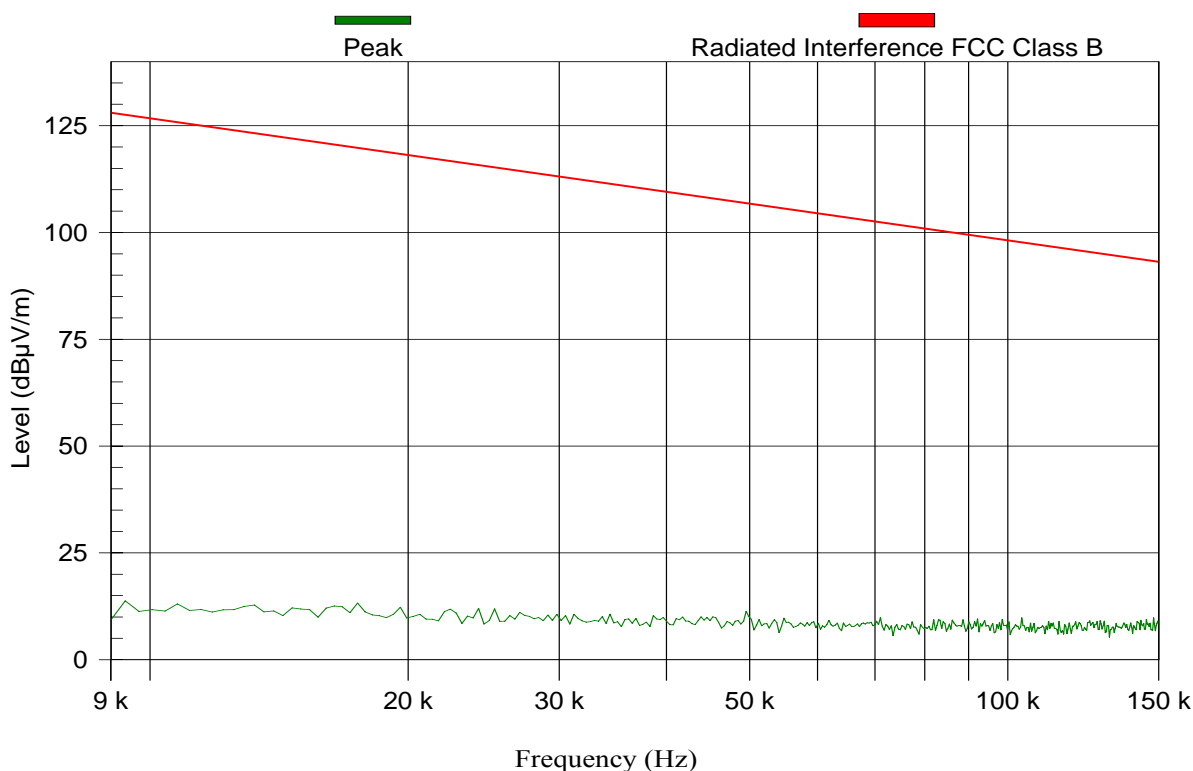

MAXIMUM RESULT DEVIATION:

Detect all peaks above 6 dB below the limit line with a maximum of 6 peaks.

None

RE FCC Class B 0.150-30 MHz

Test & EUT General Information		Receiver Setting	
EUT Name:	SA-80G	Spect Analyzer	Hewlett Packard 7405A DC Coupling
S/N:	6003990	Ref. Level:	100 dB μ V
Date of Test:	22/02/2009	RBW:	9 kHz
Test Engineer:	Ilya Arbitman	VBW:	30 kHz
Antenna:	LOOP ANT.HFH 2 Z2	Sweep Time:	Auto: 840.04 ms
Polarization:	Horizontal and Vertical	Pre Amplifier	LNA MITEQ 0.01-1GHz No-1

TEST REMARKS: Thursday, January 22, 2009 11:04:32 AM
RADIATED EMISSION PART 15.231 & 15.205

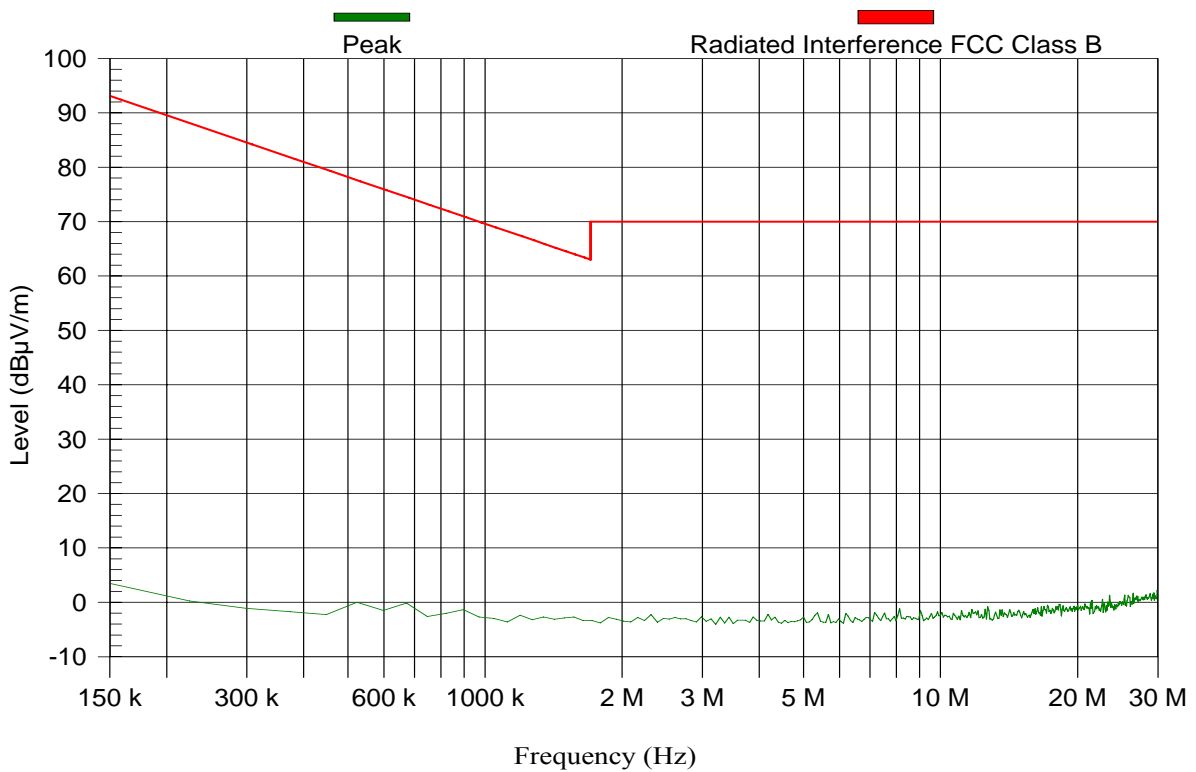

MAXIMUM RESULT DEVIATION:

Detect all peaks above 6 dB below the limit line with a maximum of 6 peaks.
None

FCC 30-1000 Hz TX HOR

Test & EUT General Information		Receiver Setting	
EUT Name:	SA-80G	Spect Analyzer	Hewlett Packard 7405 AC coupling
S/N:	6003990	Ref. Level:	90 dB μ V
Date of Test:	21/02/2009	RBW:	120 kHz
Test Engineer:	Ilya Arbitman	VBW:	1000 kHz
Antenna:	Frankonia BTA red -L_A 3m	Sweep Time:	Auto: 151.88 ms
Polarization:	Horizontal and Vertical	Pre Amplifier	LNA MITEQ 0.01-1GHz No-1

TEST REMARKS: Wednesday, January 21, 2009 3:31:53 PM
RADIATED EMISSION PART 15.231 & 15.205

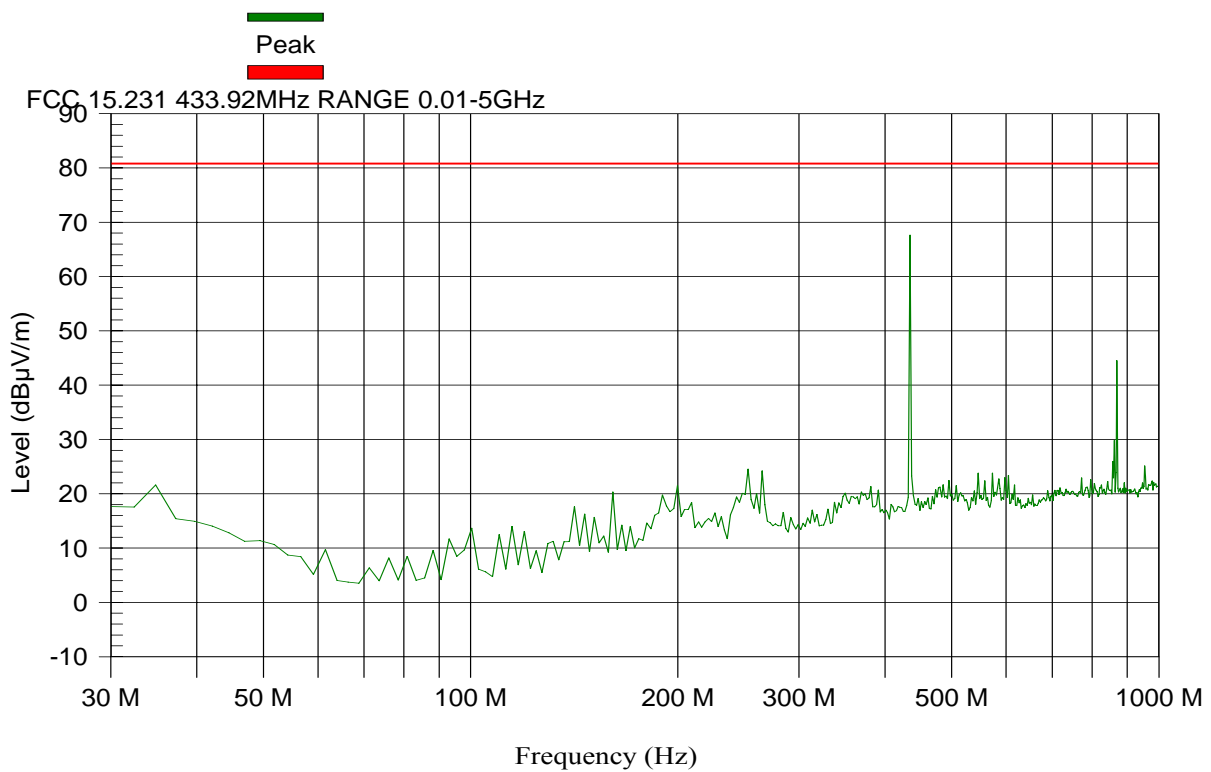

MAXIMUM RESULT DEVIATION:

Detect all peaks above 6 dB below the limit line with a maximum of 6 peaks.
None

FCC 1-2.9 GHz

Test & EUT General Information		Receiver Setting	
EUT Name:	SA-80G	Spect Analyzer	Hewlett Packard 7405 AC coupling
S/N:	6003990	Ref. Level:	90 dB μ V
Date of Test:	21/02/2009	RBW:	1000 kHz
Test Engineer:	Ilya Arbitman	VBW:	3 MHz
Antenna:	ARA DRG-118A 1-18GHz SER 1317	Sweep Time:	Auto: 10 ms
Polarization:	Horizontal and Vertical	Pre Amplifier	pre amp 1GHz-4GHz

TEST REMARKS: Wednesday, January 21, 2009 4:00:00 PM
RADIATED EMISSION PART 15.231 & 15.205

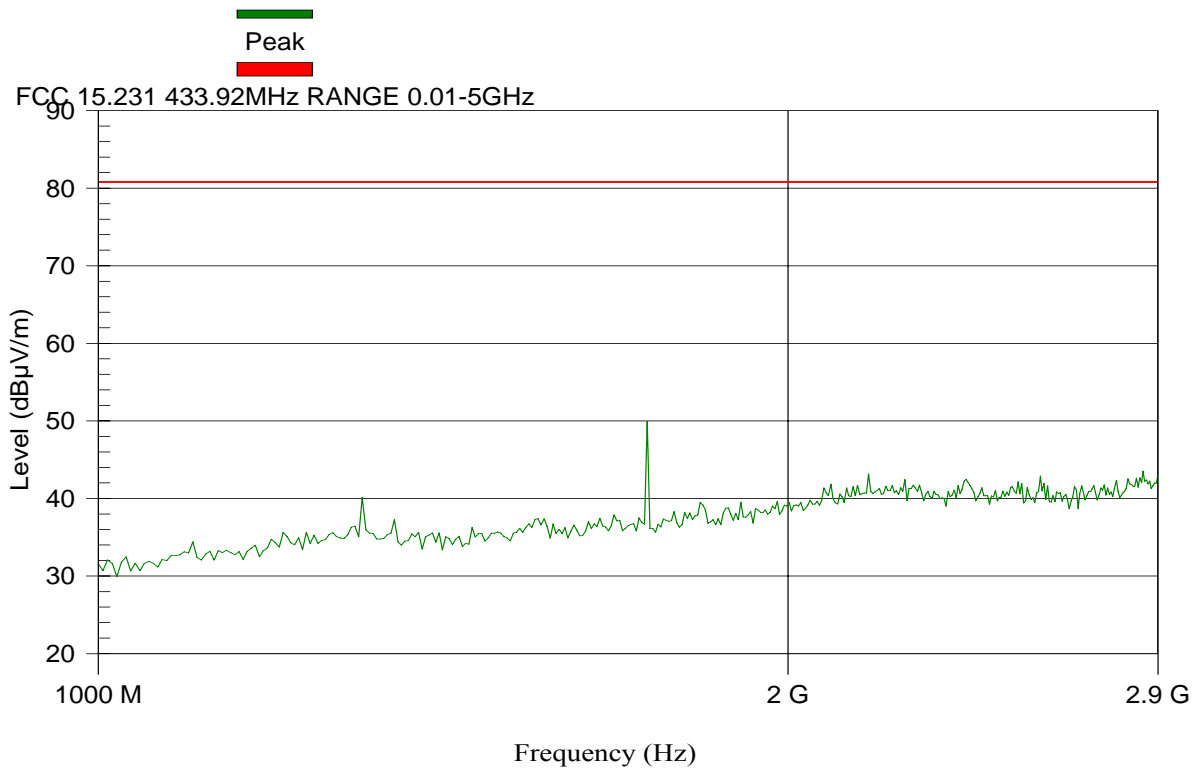

MAXIMUM RESULT DEVIATION:

Detect all peaks above 6 dB below the limit line with a maximum of 6 peaks.

None

FCC 2.9-5 GHz

Test & EUT General Information		Receiver Setting	
EUT Name:	SA-80G	Spect Analyzer	Hewlett Packard 7405 AC coupling
S/N:	6003990	Ref. Level:	90 dB μ V
Date of Test:	21/02/2009	RBW:	1000 kHz
Test Engineer:	Ilya Arbitman	VBW:	1000 kHz
Antenna:	ARA DRG-118A 1-18GHz SER 1317	Sweep Time:	Auto: 10 ms
Polarization:	Horizontal and Vertical	Pre Amplifier	PLANAR 2-18 GHz 40dB

TEST REMARKS: Wednesday, January 21, 2009 4:56:20 PM
RADIATED EMISSION PART 15.231 & 15.205

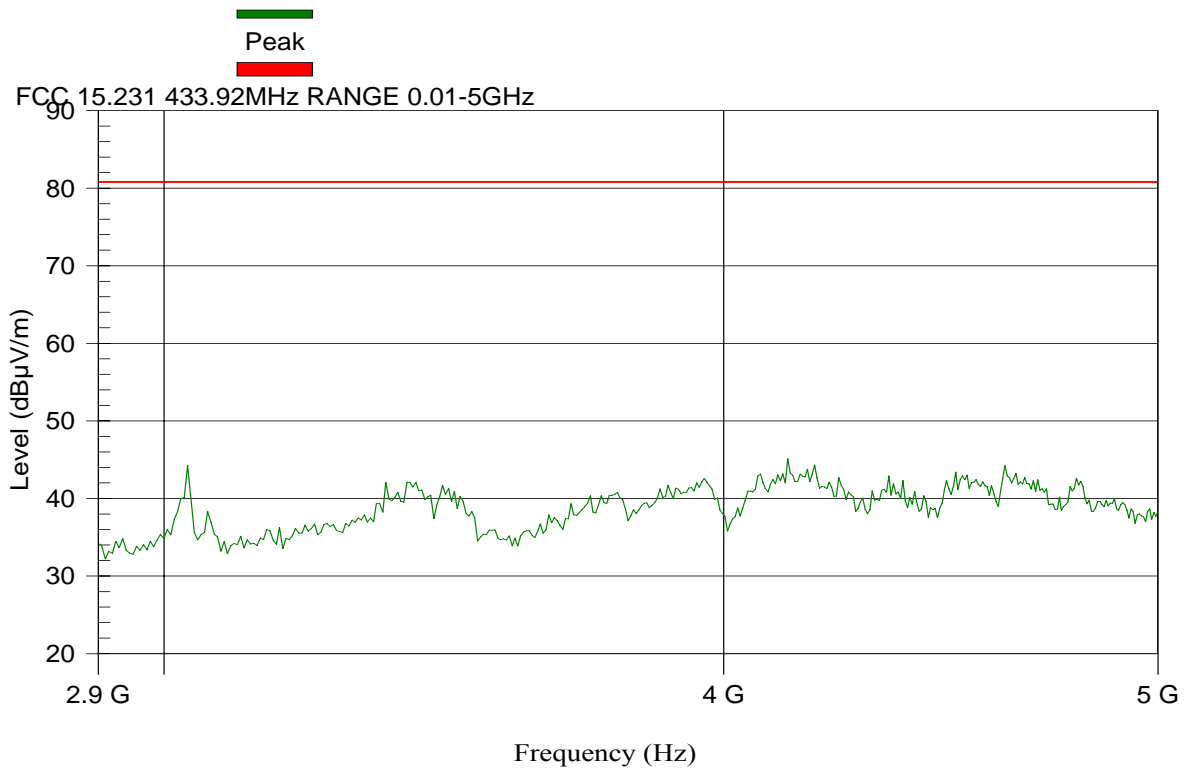

MAXIMUM RESULT DEVIATION:

Detect all peaks above 6 dB below the limit line with a maximum of 6 peaks.

None

d. Radiated emission part 15.209

Test Results Plot No 8

RE FCC Class B 9-150 KHz

Test & EUT General Information		Receiver Setting	
EUT Name:	SA-80G	Spect Analyzer	Hewlett Packard 7405A DC Coupling
S/N:	6003990	Ref. Level:	110 dB μ V
Date of Test:	22/07/2009	RBW:	200 Hz
Test Engineer:	Ilya Arbitman	VBW:	300 Hz
Antenna:	LOOP ANT.HFH 2 Z2	Sweep Time:	Auto: 12.69 s
Polarization:	Vertical	Pre Amplifier	LNA MITEQ 0.01-1GHz No-1

TEST REMARKS: Wednesday, July 22, 2009 6:33:38 PM

FCC PART 15.209

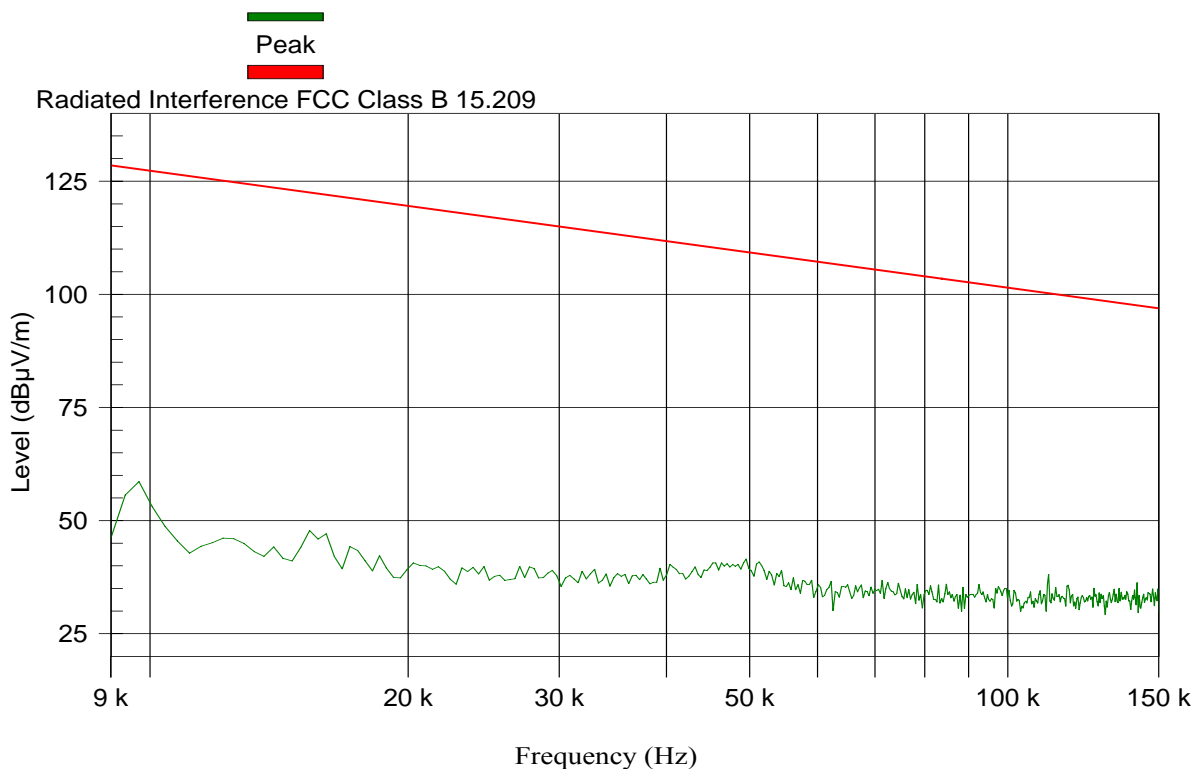

MAXIMUM RESULT DEVIATION:

Detect all peaks above 6 dB below the limit line with a maximum of 6 peaks.

None

RE FCC Class B 0.150-30MHz

Test & EUT General Information		Receiver Setting	
EUT Name:	SA-80G	Spect Analyzer	Hewlett Packard 7405A DC Coupling
S/N:	6003990	Ref. Level:	100 dB μ V
Date of Test:	22/07/2009	RBW:	9 kHz
Test Engineer:	Ilya Arbitman	VBW:	30 kHz
Antenna:	LOOP ANT.HFH 2 Z2	Sweep Time:	Auto: 816.12 ms
Polarization:	Vertical	Pre Amplifier	LNA MITEQ 0.01-1GHz No-1

TEST REMARKS: Wednesday, July 22, 2009 6:34:32 PM

FCC PART 15.209

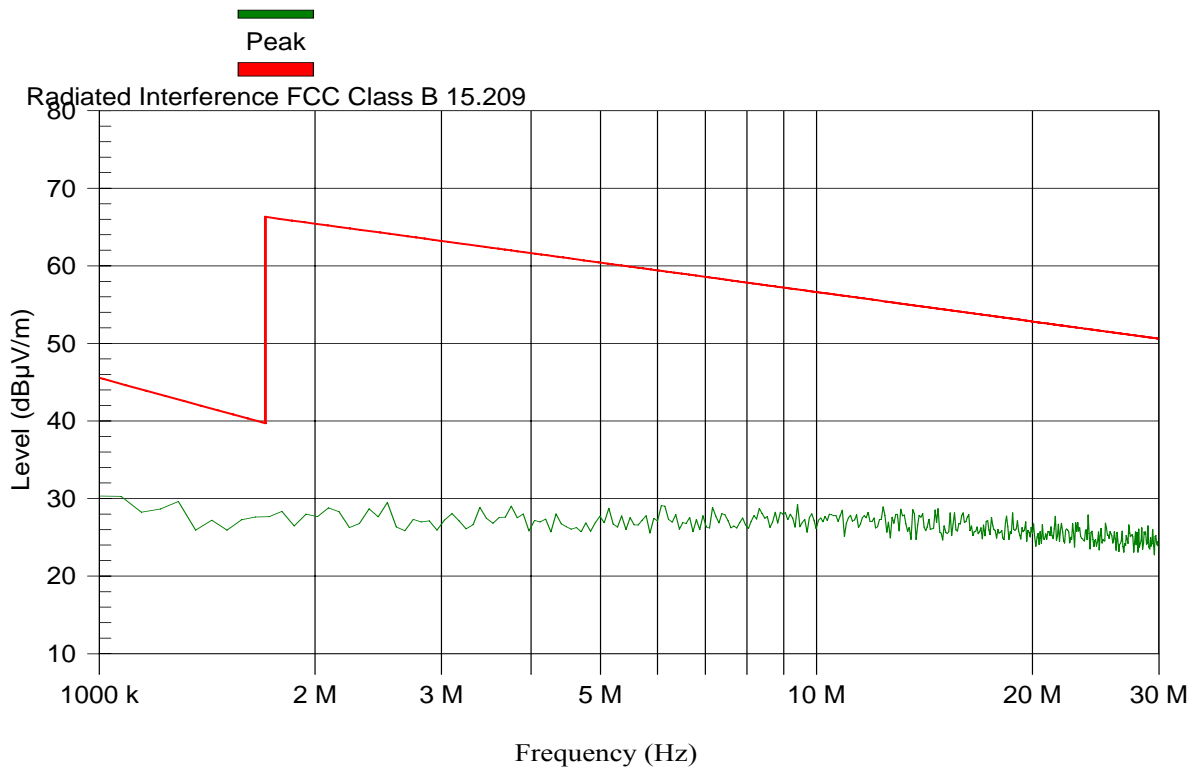

MAXIMUM RESULT DEVIATION:

Detect all peaks above 6 dB below the limit line with a maximum of 6 peaks.

None.

RE FCC Class B 30-1000MHz Spurious Emission

Test & EUT General Information		Receiver Setting	
EUT Name:	SA-80G	Spect Analyzer	Hewlett Packard 7405 AC coupling
S/N:	6003990	Ref. Level:	70 dB μ V
Date of Test:	22/07/2009	RBW:	120 kHz
Test Engineer:	Ilya Arbitman	VBW:	1000 kHz
Antenna:	Frankonia BTA red -L_A 3m	Sweep Time:	Auto: 151.88 ms
Polarization:	Horizontal and Vertical	Pre Amplifier	LNA MITEQ 0.01-1GHz No-3

TEST REMARKS: Wednesday, July 22, 2009 4:18:00 PM

FCC PART 15.209

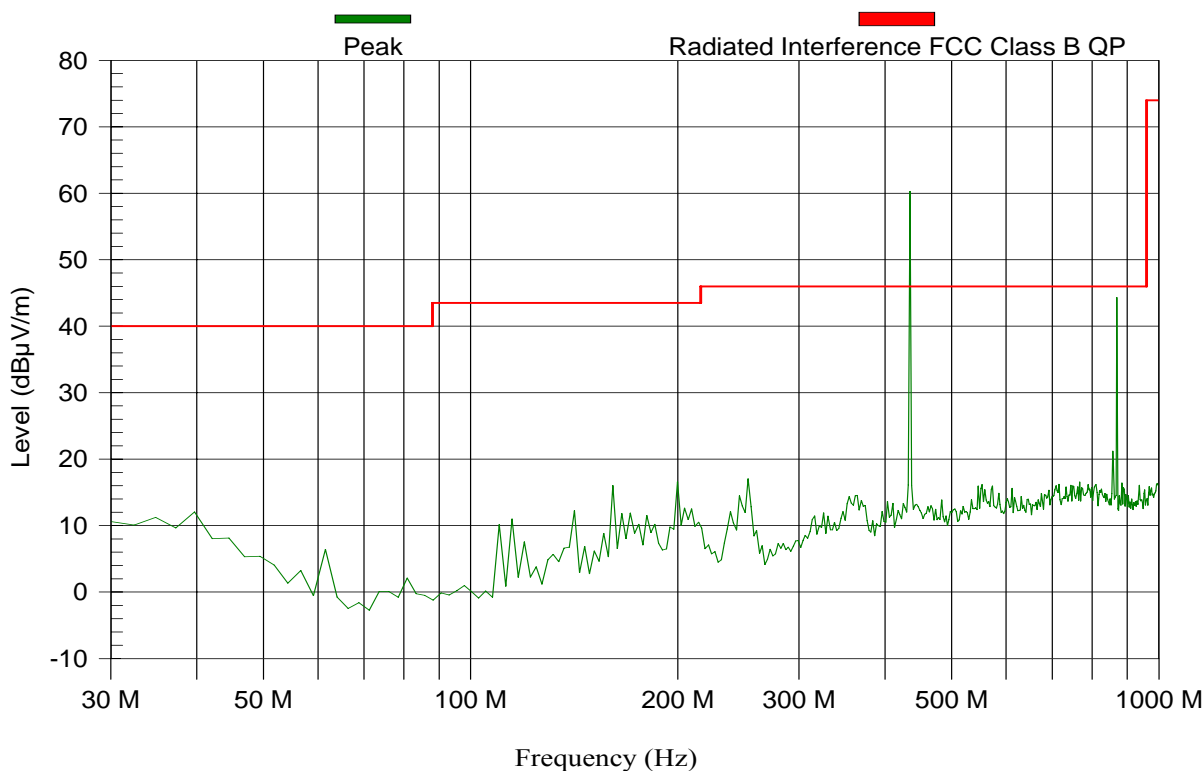

MAXIMUM RESULT DEVIATION:

Detect all peaks above 6 dB below the limit line with a maximum of 6 peaks.

Nr	Frequency (MHz)	PK MaxHold (dB μ V/m)	QP Value (dB μ V/m)	QP Limit (dB μ V/m)	Result	Angle (degrees)	Height (m)	H/V
1	434.975	60.3	10.5	46	Fail	0	1.8	V
2	867.853	44.5	44.2	46	Pass	0	1.8	V

FCC 1-2.9GHz

Test & EUT General Information		Receiver Setting	
EUT Name:	SA-80G	Spect Analyzer	Hewlett Packard 7405 AC coupling
S/N:	6003990	Ref. Level:	90 dB μ V
Date of Test:	23/07/2009	RBW:	1000 kHz
Test Engineer:	Ilya Arbitman	VBW:	3 MHz
Antenna:	ARA DRG-118A 1-18GHz SER 1317	Sweep Time:	Auto: 10 ms
Polarization:	Horizontal and Vertical	Pre Amplifier	pre amp 1GHz-4GHz

TEST REMARKS: Thursday, July 23, 2009 9:46:34 AM

FCC PART 15.209

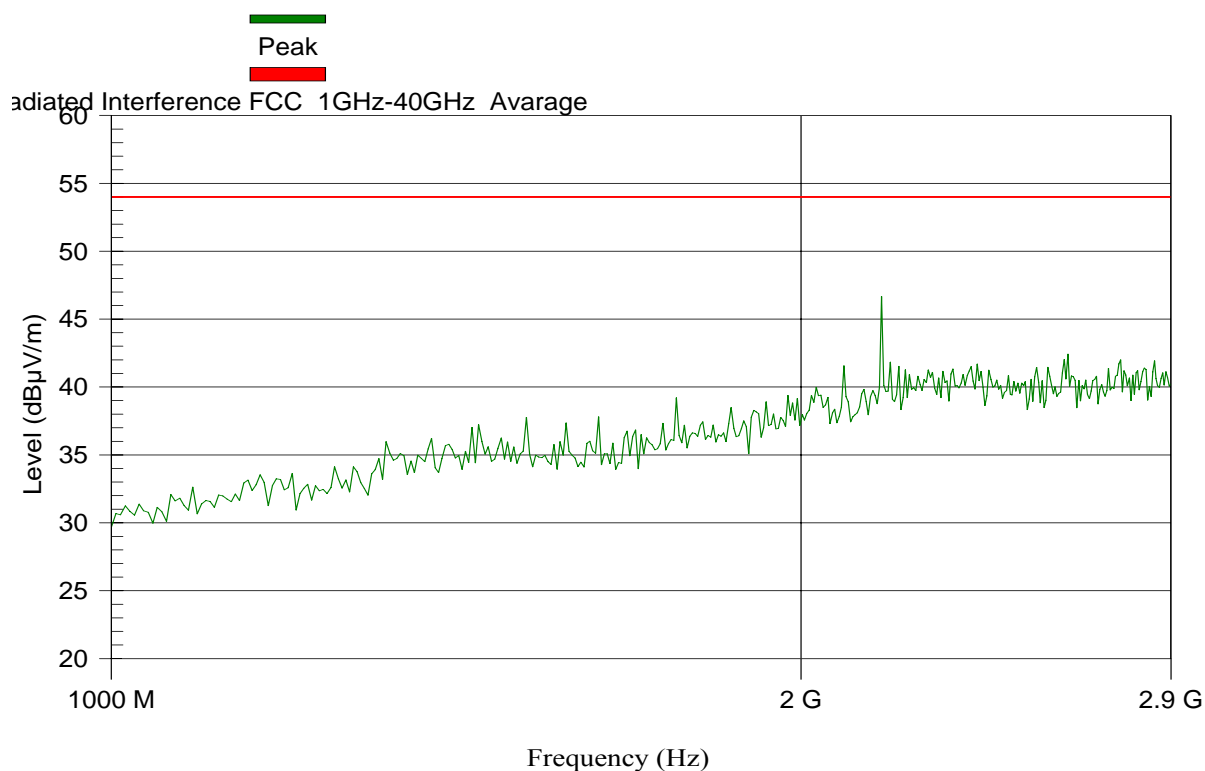

MAXIMUM RESULT DEVIATION:

Detect all peaks above 6 dB below the limit line with a maximum of 6 peaks.

Nr	Frequency (MHz)	PK MaxHold (dB μ V/m)	AVG Value (dB μ V/m)	AVG Limit (dB μ V/m)	Result	Angle (degrees)	Height (m)	H/V
1	2169.713	48.3	43.4	54	Pass	0	1	H

FCC 2.9-5GHz

Test & EUT General Information		Receiver Setting	
EUT Name:	SA-80G	Spect Analyzer	Hewlett Packard 7405 AC coupling
S/N:	6003990	Ref. Level:	90 dB μ V
Date of Test:	23/07/2009	RBW:	1000 kHz
Test Engineer:	Ilya Arbitman	VBW:	1000 kHz
Antenna:	ARA DRG-118A 1-18GHz SER 1317	Sweep Time:	Auto: 10 ms
Polarization:	Horizontal and Vertical	Pre Amplifier	PLANAR 2-18 GHz 40dB

TEST REMARKS: Thursday, July 23, 2009 9:25:50 AM

FCC PART 15.209

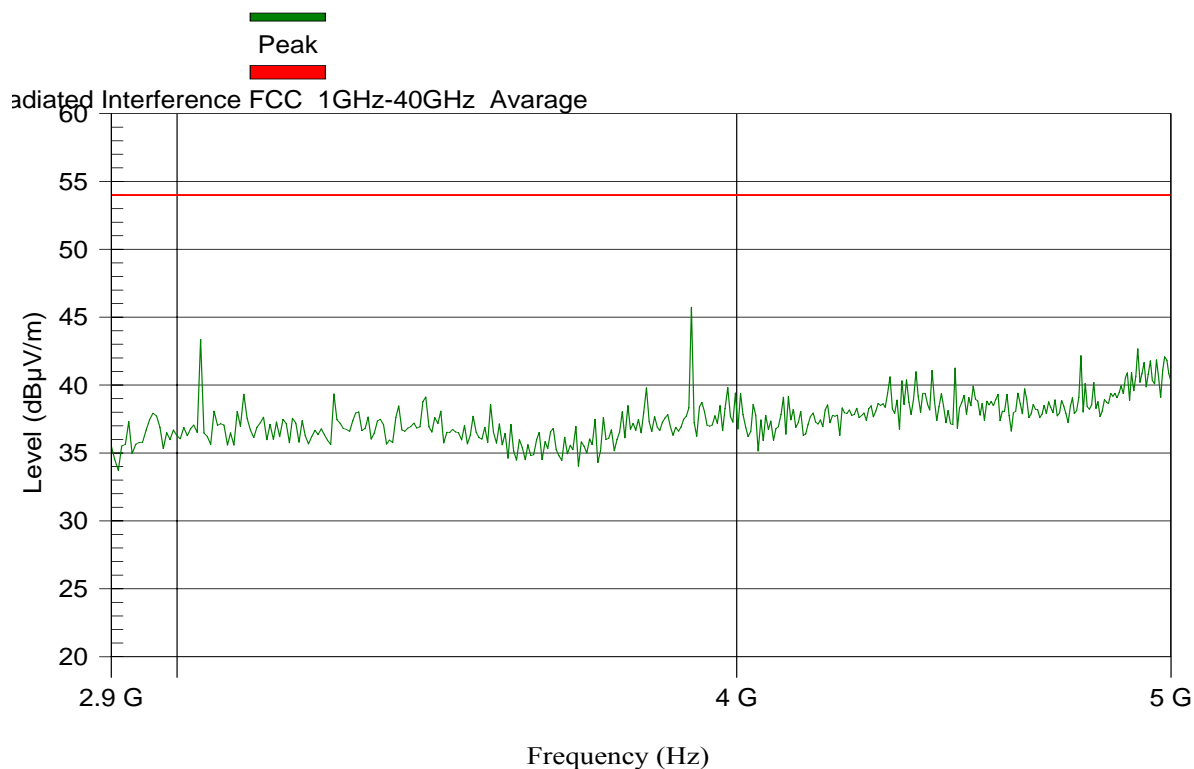

MAXIMUM RESULT DEVIATION:

Detect all peaks above 6 dB below the limit line with a maximum of 6 peaks.

Nr	Frequency (MHz)	PK Value (dB μ V/m)	AVG Value (dB μ V/m)	AVG Limit (dB μ V/m)	Result	Angle (degrees)	Height (m)	H/V
1	3037.484	46.3	41.4	54	Pass	355	1	H
2	3905.311	48.4	44.2	54	Pass	5	1	V
3	4773.064	46.5	39.4	54	Pass	0	1	V

e. Power Line Conducted interference part 15.207

Test Results Plot No 13

FCC Part 15 0.15-0.50 MHz PHASE

Test & EUT General Information		Receiver Setting	
EUT Name:	SA-80G	Spect Analyzer	Hewlett Packard 7405A DC Coupling
S/N:	6003990	Ref. Level:	80 dB μ V
Date of Test:	25/01/2009	RBW:	9 kHz
Test Engineer:	Ilya Arbitman	VBW:	1000 kHz
Antenna:	No Description Available	Sweep Time:	Auto: 11.52 ms
Polarization:	1 polarization	Pre Amplifier	Attenuator 20db

TEST REMARKS: Sunday, January 25, 2009 10:48:42 AM
PHASE LINE; WITH P.S: GS-AD (4)

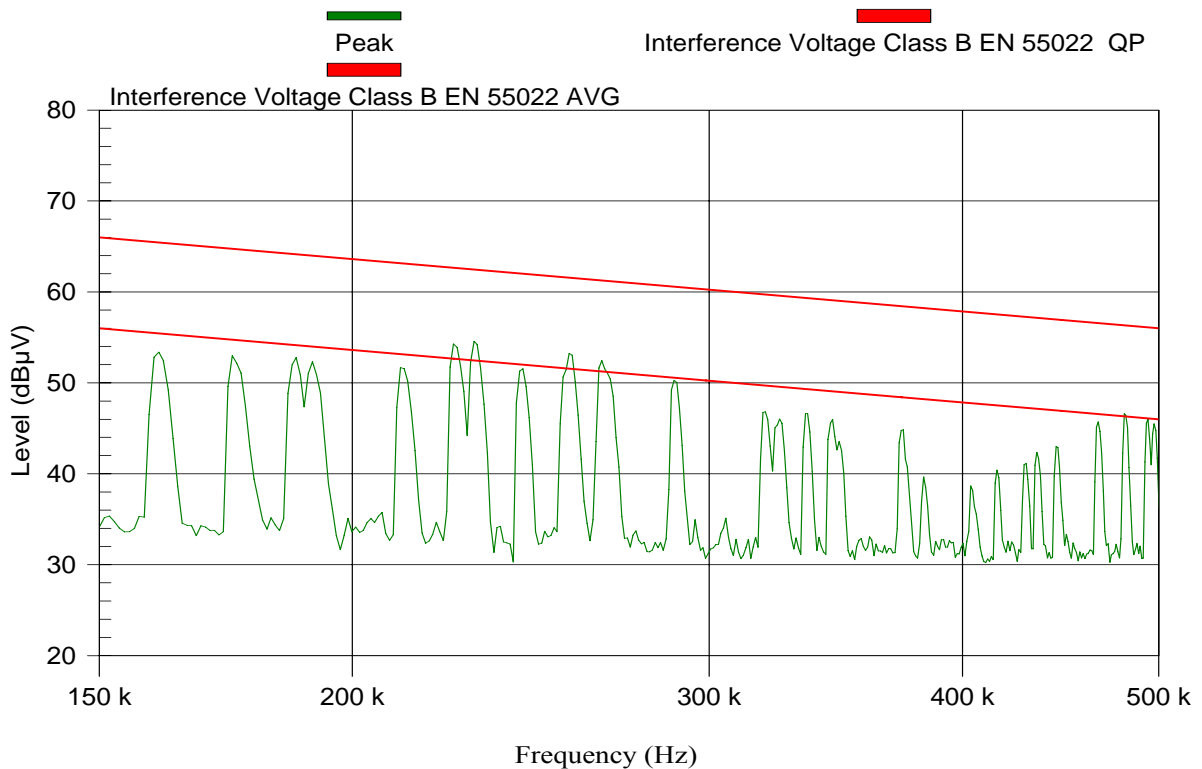

MAXIMUM RESULT DEVIATION:

Detect all peaks above 6 dB below the limit line with a maximum of 6 peaks.

Nr	Frequency (MHz)	PK MaxHold (dB μ V)	AVG Value (dB μ V)	QP Value (dB μ V)	AVG Limit (dB μ V)	QP Limit (dB μ V)	Result	Line
1	0.155	55.8	5.1	48.2	55.7	65.7	Pass	Line 1
2	0.181	55.3	3.8	47.8	54.5	64.5	Pass	Line 1
3	0.22	54.6	2.8	46.7	52.8	62.8	Pass	Line 1
4	0.26	52.7	1.8	45	51.4	61.4	Pass	Line 1
5	0.288	49.2	1.1	41.9	50.6	60.6	Pass	Line 1
6	0.477	46.2	-1.2	37.9	46.4	56.4	Pass	Line 1

FCC Part 15 0.5-30 MHz PHASE

Test & EUT General Information		Receiver Setting	
EUT Name:	SA-80G	Spect Analyzer	Hewlett Packard 7405A DC Coupling
S/N:	6003990	Ref. Level:	80 dB μ V
Date of Test:	25/01/2009	RBW:	9 kHz
Test Engineer:	Ilya Arbitman	VBW:	1000 kHz
Antenna:	No Description Available	Sweep Time:	Auto: 819.45 ms
Polarization:	4 polarization	Pre Amplifier	Attenuator 20db

TEST REMARKS: Sunday, January 25, 2009 10:50:49 AM
PHASE LINE; WITH P.S: GS-AD (4)

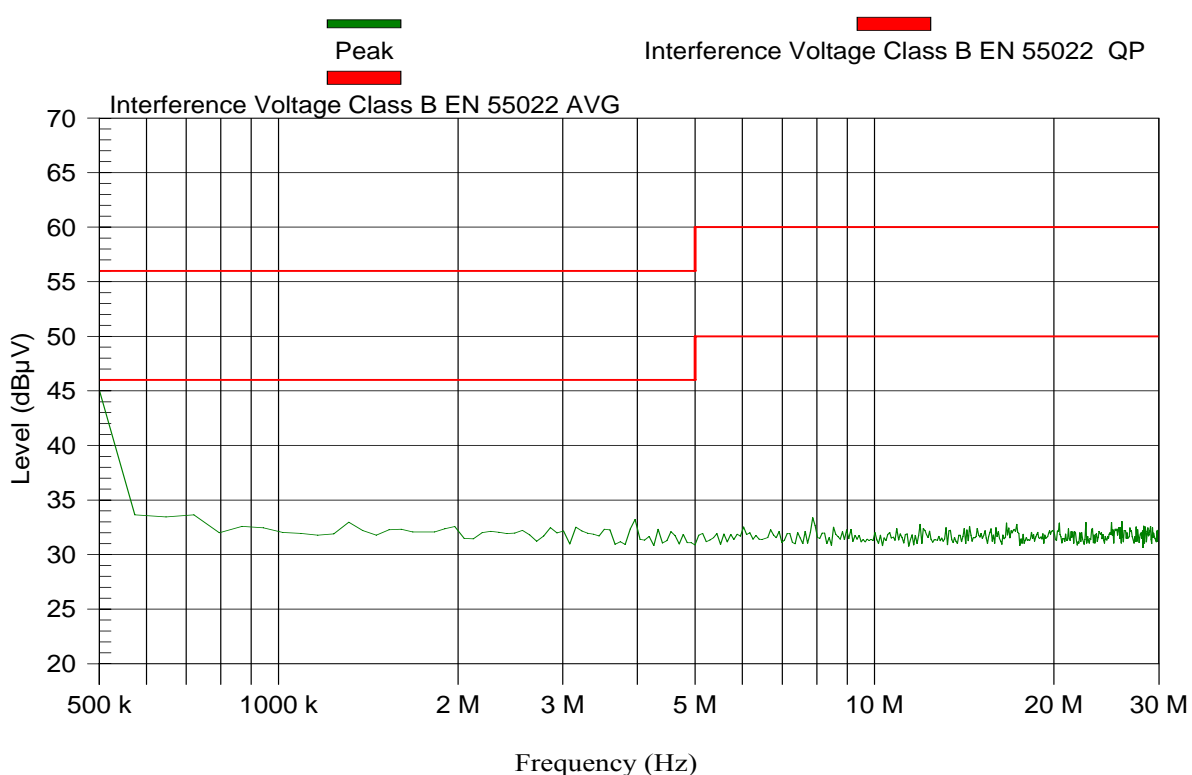

MAXIMUM RESULT DEVIATION:

Detect all peaks above 6 dB below the limit line with a maximum of 6 peaks.

Nr	Frequency (MHz)	PK MaxHold (dB μ V)	AVG Value (dB μ V)	QP Value (dB μ V)	AVG Limit (dB μ V)	QP Limit (dB μ V)	Result	Line
1	0.504	45	-1.6	36.4	46	56	Pass	Line 1

FCC Part 15 0.15-0.50 MHz NEUTRAL

Test & EUT General Information		Receiver Setting	
EUT Name:	SA-80G	Spect Analyzer	Hewlett Packard 7405A DC Coupling
S/N:	6003990	Ref. Level:	80 dB μ V
Date of Test:	25/01/2009	RBW:	9 kHz
Test Engineer:	Ilya Arbitman	VBW:	1000 kHz
Antenna:	No Description Available	Sweep Time:	Auto: 11.52 ms
Polarization:	2 polarization	Pre Amplifier	Attenuator 20db

TEST REMARKS: Sunday, January 25, 2009 11:02:13 AM
NEUTRAL LINE; WITH P.S: GS-AD (4)

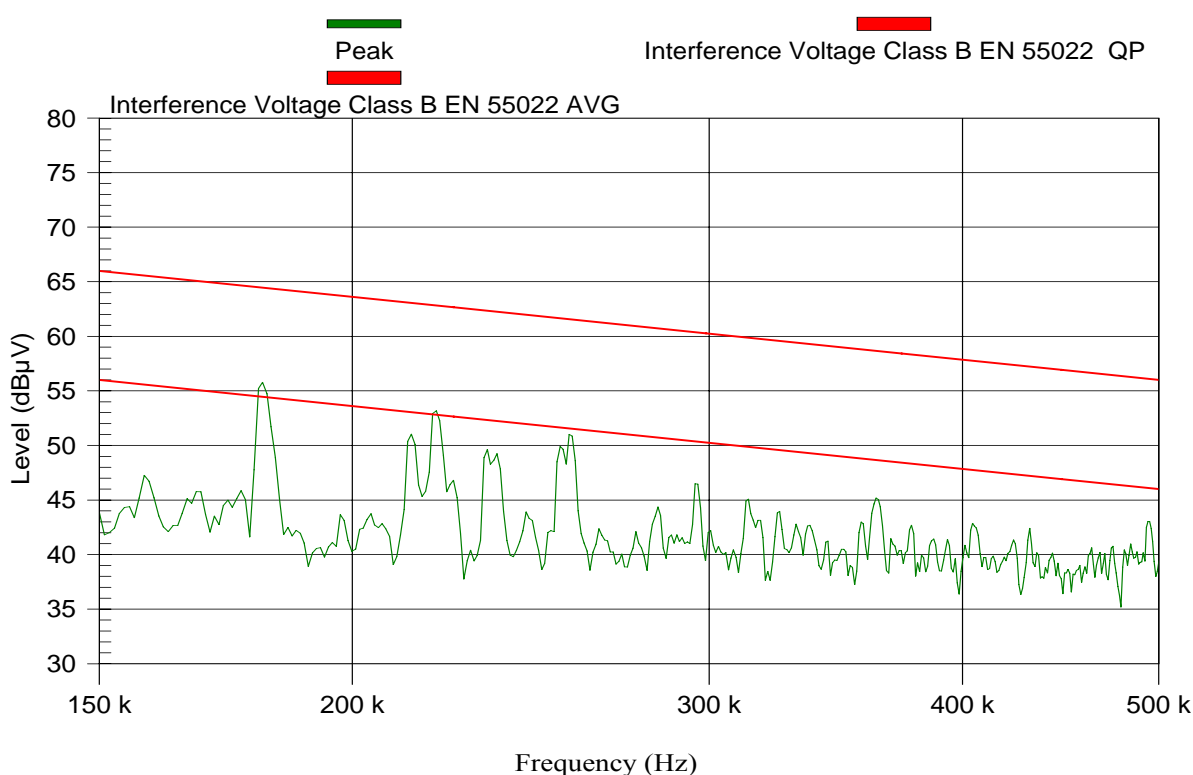

MAXIMUM RESULT DEVIATION:

Detect all peaks above 6 dB below the limit line with a maximum of 6 peaks.

Nr	Frequency (MHz)	PK MaxHold (dB μ V)	AVG Value (dB μ V)	QP Value (dB μ V)	AVG Limit (dB μ V)	QP Limit (dB μ V)	Result	Line
1	0.163	56.9	14.2	47.9	55.3	65.3	Pass	Neutral
2	0.187	54.8	13.5	47	54.2	64.2	Pass	Neutral
3	0.217	54.2	12.6	45.9	52.9	62.9	Pass	Neutral
4	0.248	52.1	11.8	44	51.8	61.8	Pass	Neutral
5	0.361	45.1	30	38.9	48.7	58.7	Pass	Neutral
6	0.477	43.6	29.3	38.1	46.4	56.4	Pass	Neutral

FCC Part 15 0.5-30 MHz NEUTRAL

Test & EUT General Information		Receiver Setting	
EUT Name:	SA-80G	Spect Analyzer	Hewlett Packard 7405A DC Coupling
S/N:	6003990	Ref. Level:	60 dB μ V
Date of Test:	25/01/2009	RBW:	9 kHz
Test Engineer:	Ilya Arbitman	VBW:	1000 kHz
Antenna:	No Description Available	Sweep Time:	Auto: 819.45 ms
Polarization:	3 polarization	Pre Amplifier	Attenuator 20db

TEST REMARKS: Sunday, January 25, 2009 11:09:32 AM
NEUTRAL LINE; WITH P.S: GS-AD (4)

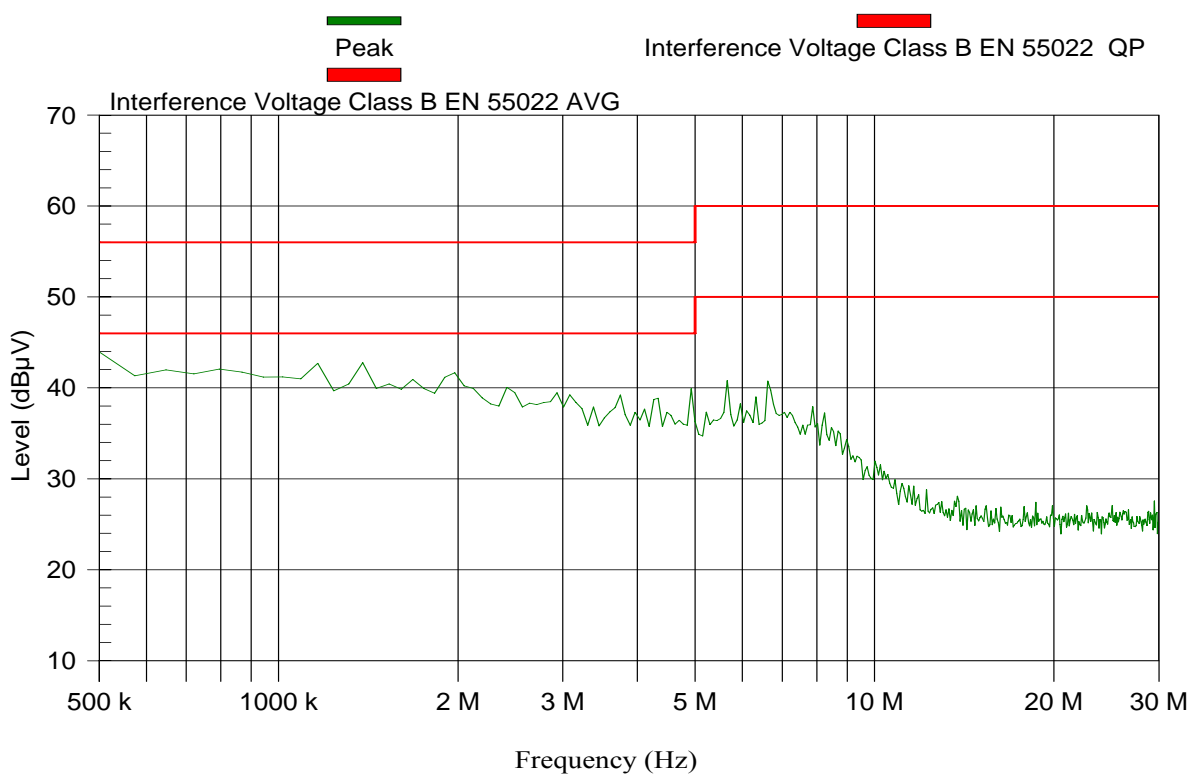

MAXIMUM RESULT DEVIATION:

Detect all peaks above 6 dB below the limit line with a maximum of 6 peaks.

Nr	Frequency (MHz)	PK MaxHold (dB μ V)	AVG Value (dB μ V)	QP Value (dB μ V)	AVG Limit (dB μ V)	QP Limit (dB μ V)	Result	Line
1	0.611	44.4	28.7	37	46	56	Pass	Neutral
2	1.048	40.8	27.5	36	46	56	Pass	Neutral
3	1.54	40.5	26.8	35.2	46	56	Pass	Neutral
4	1.573	41.2	26.7	35.2	46	56	Pass	Neutral
5	1.676	42.4	26.5	35.1	46	56	Pass	Neutral
6	2.154	40.3	25.9	34.4	46	56	Pass	Neutral

Test Results Plot No 17

Transmission time

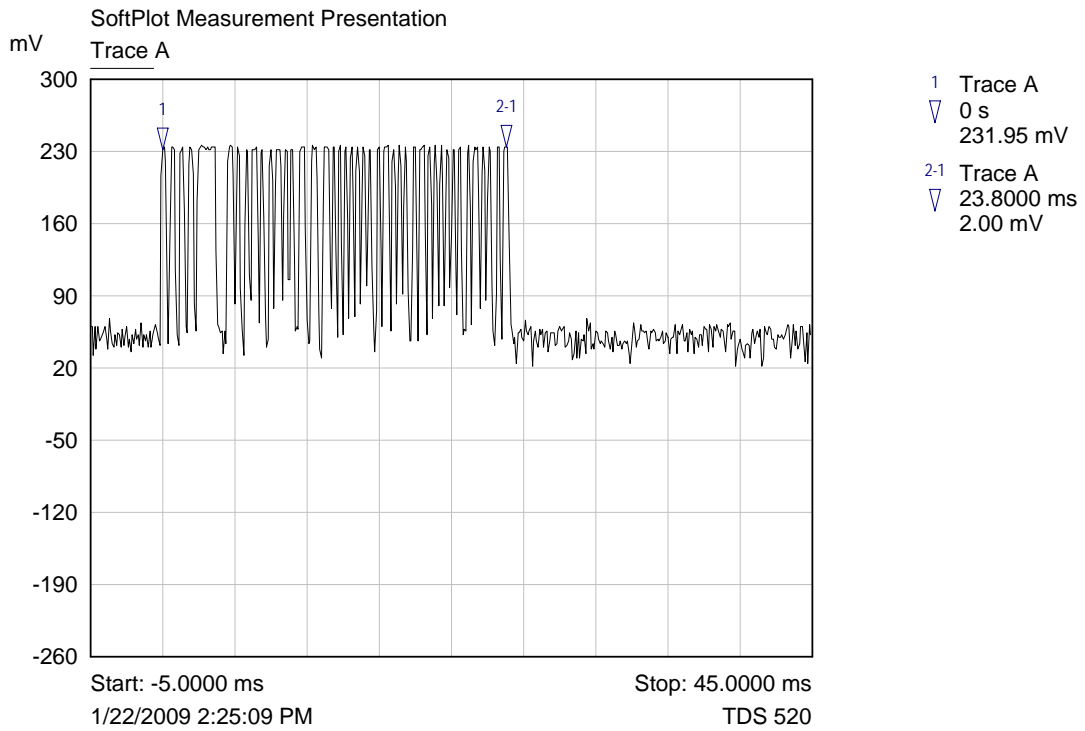

Test Results Plot No 18

Repetitive transmission time

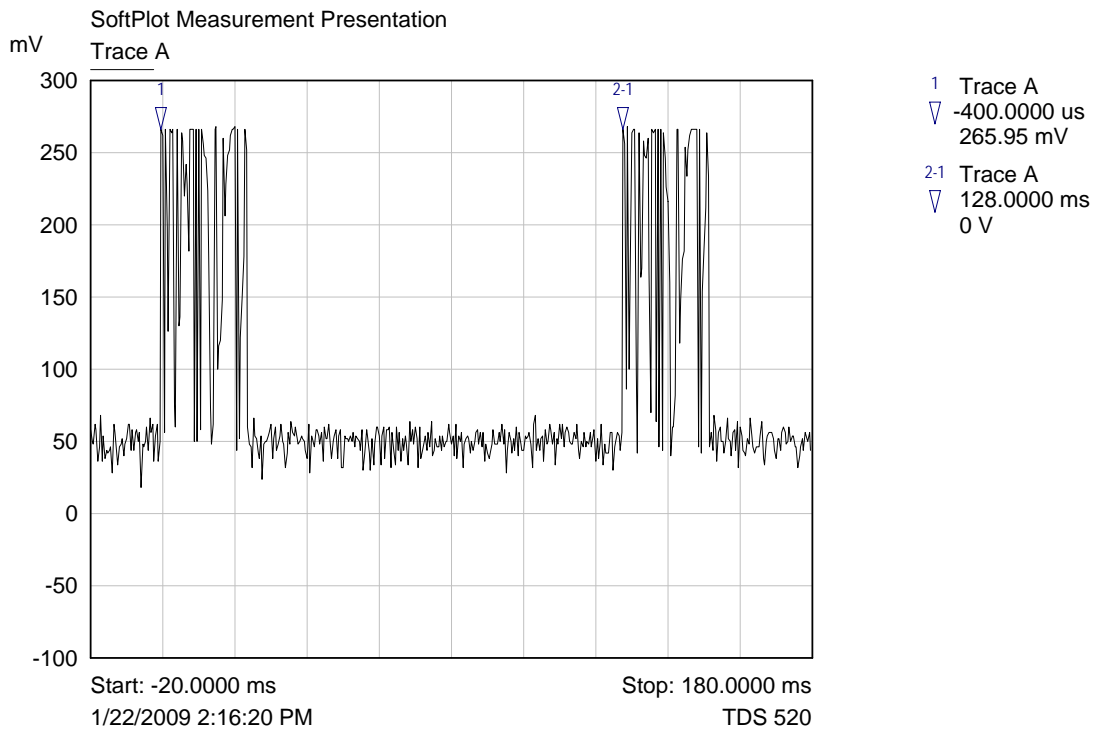

Test Results Plot No 19

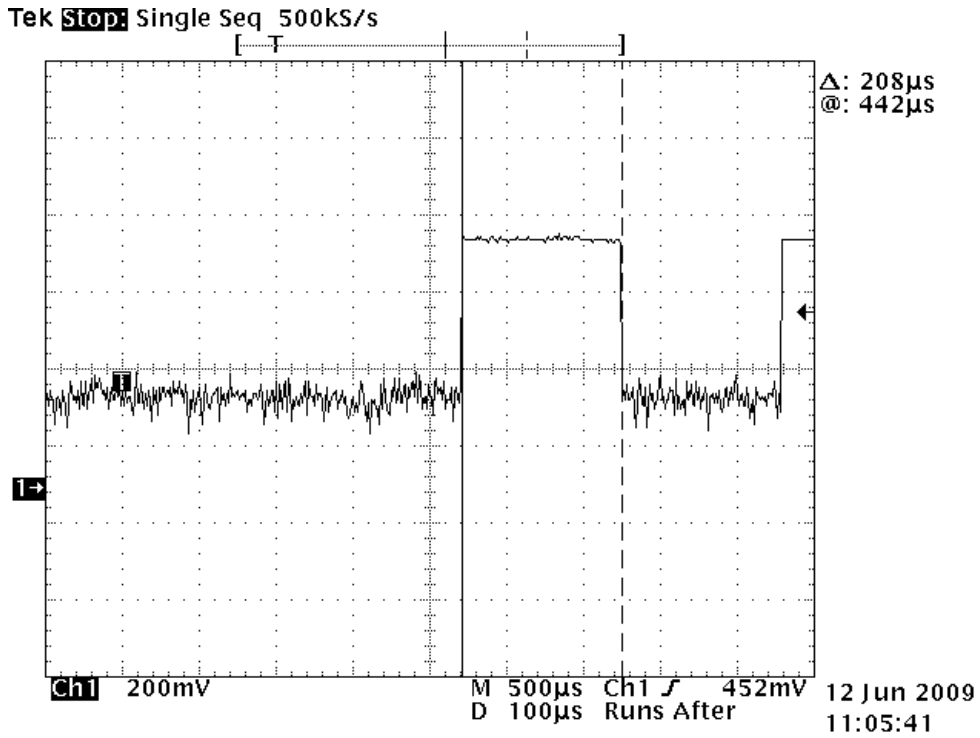

Test Results Plot No 20

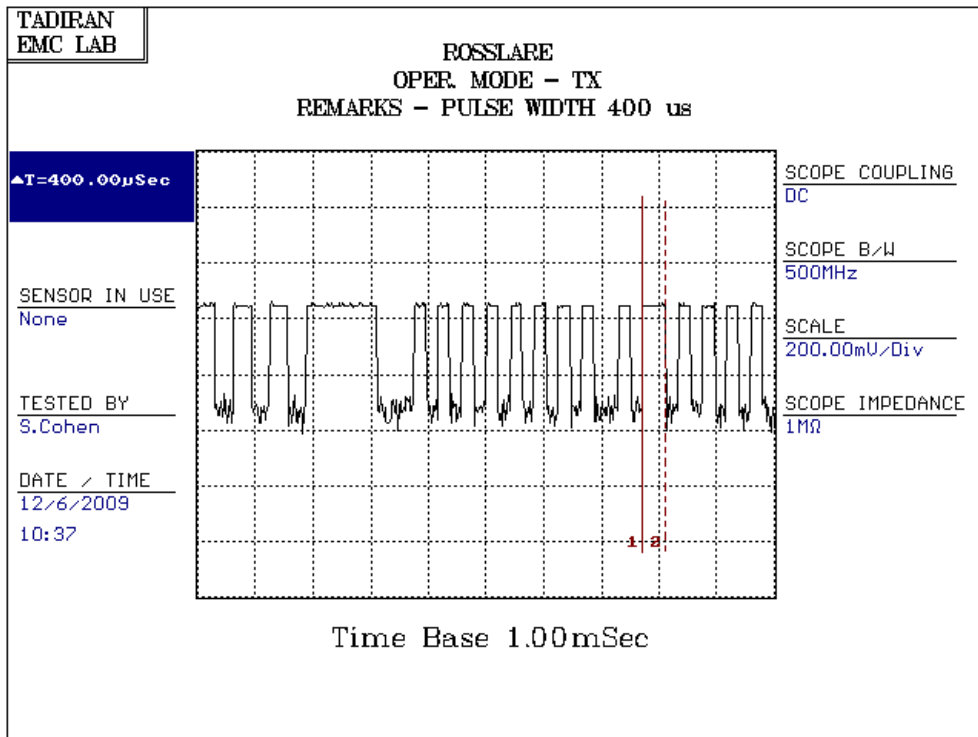

Test Results Plot No 21

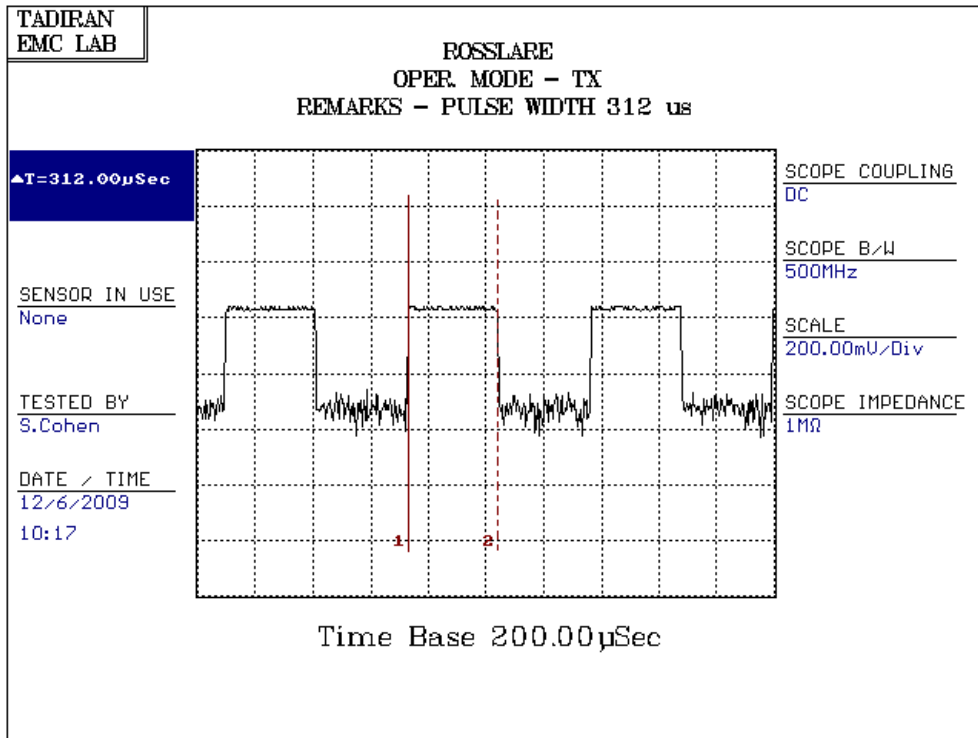

Test Results Plot No 22

Tek **Stop** Single Seq 250kS/s

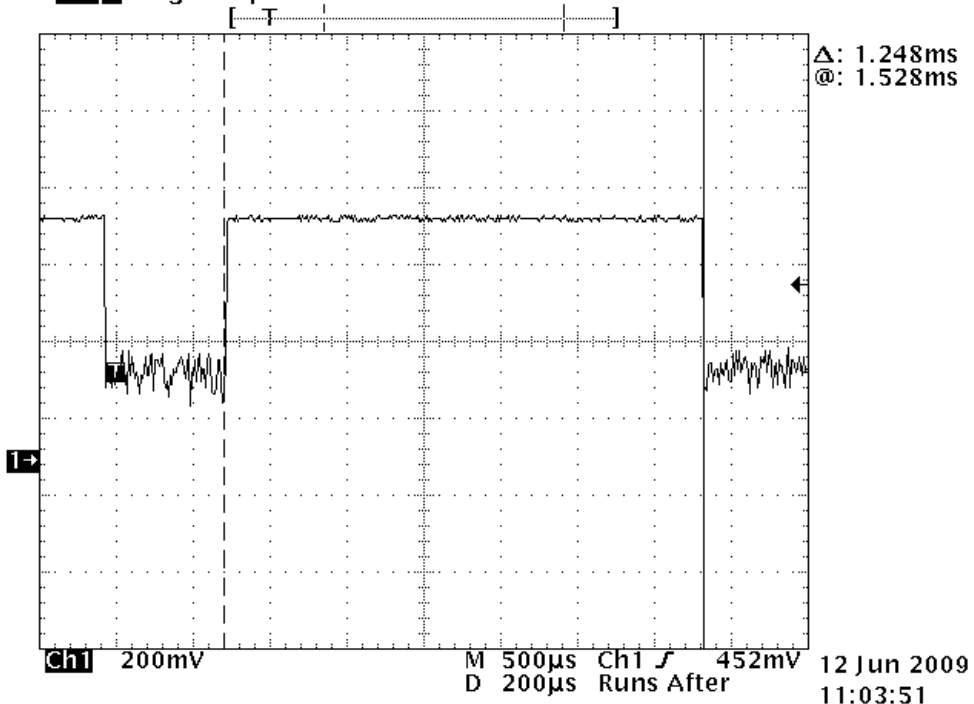

$$TX/ON=4 \times 312\mu s + 1248\mu s + 43 \times 208\mu s + 5 \times 400\mu s = 13.44\text{msec}$$

$$\text{Average Factor} = 20\log(TXON/100)$$

$$20\log 13.44/100 = -17.43$$

10 CORRECTION FACTORS

DOUBLE RIDGE HORN Model 3105 S/N:00-50C2-1C-C468 2052 Antenna Factor

Frequency (MHz)	Antenna Factor (db/m)
1000	24.4
2000	26.2
3000	30
4000	32.6
5000	33.8
6000	34.9
7000	36.2
8000	36.9
9000	37.8
10000	38.4
11000	39.1
12000	40.1
13000	42
14000	40.6
15000	39.3
16000	40.3

Antenna Factor for broadband antenna model BTA-L S/N:00-50C2-1C-C468 980045L

Frequency (KHz)	Ant. Factor (db/m)	Frequency (KHz)	Ant. Factor (db/m)
30	19.05	300	14.35
32	19.13	310	14.28
34	18.74	320	14.43
36	18.03	330	14.13
38	16.61	340	14.48
40	15.44	350	14.89
45	13.66	360	15.12
50	11.52	370	15.70
55	10.04	380	15.78
60	7.68	390	16.22
65	6.11	400	16,45
70	5.47	425	16.99
75	5.98	450	17.59
80	6.86	475	17.28
85	7.20	500	17.69
90	7.47	525	18.91
95	7.23	550	19.06
100	7.20	575	18.20
105	7.30	600	18.87
110	7.37	625	18.81
115	7.02	650	19.64
120	6.82	675	19.92
125	7.05	700	20.66
130	7.83	725	21.08
135	9.61	750	21.53
140	7.93	775	22.39
145	8.03	800	22.66
150	8.29	825	22.87
160	8.72	850	22.65
170	9.18	875	23.12
180	9.05	900	23.70
190	9.80	925	23.40
200	10.61	950	23.43
210	10.34	975	23.30
220	11.21	1000	24.02
230	11.69		
240	11.62		
250	11.85		
260	12.45		
270	13.16		
280	13.48		
290	13.74		

11 ABBREVIATIONS AND ACRONYMS

The following abbreviations and acronyms are applicable in this document

BW	Bandwidth
R.BW	Resolution Bandwidth
V.BW	Video Bandwidth
db	Decibel
EMI	Electromagnetic interference
E.U.T	Equipment under test
LISN	Line impedance stabilization network
S/N	Serial number
QP	Quasi peak
PK	Peak

12 PHOTOGRAPHS





