

Tune-Up Procedure

Tune-Up TX

Content

| | |
|--|---|
| 1 Purpose..... | 2 |
| 2 General description | 3 |
| 2.1 Characteristics of the transmit burst..... | 3 |
| 2.2 GPRS/Edge Data transfer..... | 3 |
| 2.2.1 GSM850&PCS1900 allowed maximum output reduction in a multislots..... | 3 |
| 2.2.2 Edge power description..... | 4 |
| 2.3 UMTS Band2 and Band5 allowed maximum output power Configuration..... | 4 |
| 3 Parameters..... | 4 |
| 3.1 Parameters used to shape the burst..... | 4 |
| 3.2 Parameters used to define the temporal position of the burst..... | 4 |
| 3.2.1 Optimum position of the burst..... | 4 |
| 3.2.2 Optimum length of the burst..... | 5 |
| 4 Operating mode | 5 |
| 4.1 How to transmit a Tch burst (Random data), in GSM850 PCS1900 mode, at power control level max: | 5 |
| 4.2 How to stop Tx measurements: | 5 |
| 4.3 How to transmit a burst after modifying parameters..... | 6 |
| 5 Purpose..... | 6 |
| 6 Automatic frequency control | 6 |
| 7 Static frequency error and range..... | 8 |

1 Purpose

This panel gives the possibility to manage the mobile in the transmit mode.

This window includes both:

- All the parameters (frequency band, RF channel, RF level to get the desire antenna output power...) The user needs to make the mobile transmitting,
- All the parameters needed to define a transmit burst,
- All the compensation table to be able to align the mobile in production.

This Tx_commands user guide is describing:

- The characteristics of the transmit burst,
- All the parameters used in the transmit mode,
- The operating mode to make the mobile transmitting

2 General description

2.1 Characteristics of the transmit burst for GSM850/PCS

The power levels and the shape of a transmit burst are controlled by the power amplifier controller integrated in the MT8382. The burst is generated by a 10-bit DAC from the MT8382 as shown below:

The ramping shape is referenced with the rising edge of Tx-ON (from the Baseband).

There are two types of parameters define the transmit burst: the first one define the shapes of the burst, and the second one define the temporal position of the burst.

The rising and the falling edge of the transmit burst are determined by a set of 32 DAC code values $n = 0 \dots 31$.

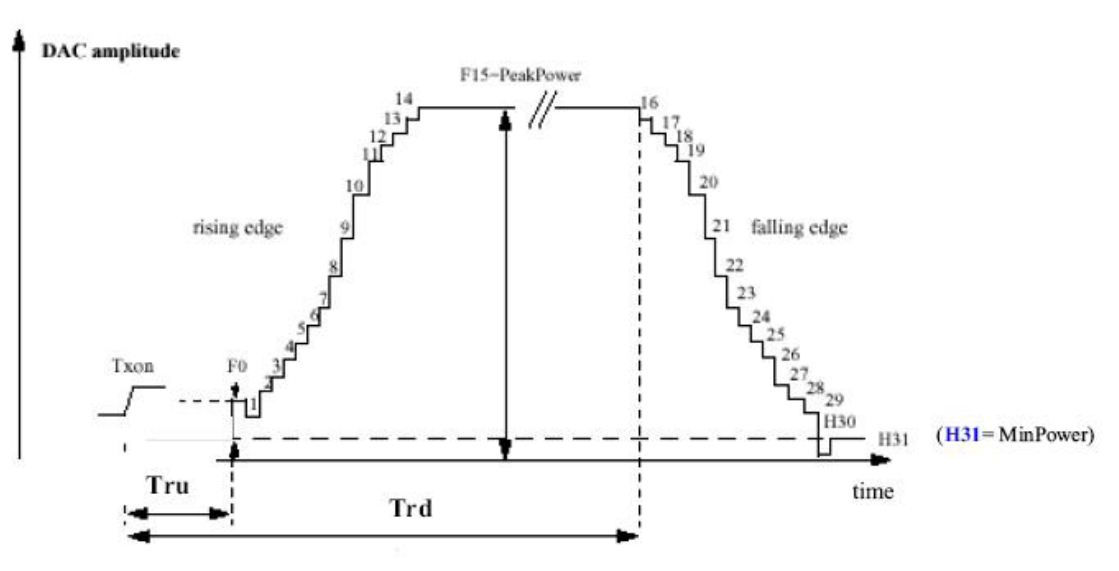

$$Tru = TxTRUDefault + \Delta TRU_P + \Delta TRU_T$$

$$Trd = TxTRD_NBDefault + \Delta TRD_P \text{ (for a normal burst).}$$

$$Trd = TxTRD_ABDefault + \Delta TRD_P \text{ (for an access burst).}$$

2.2 GPRS Data Transfer for GSM850/PCS1900

2.2.1 GSM850&PCS1900 allowed maximum output reduction in a multislot

GSM mobile phones use a Time Division Multiple Access (TDMA) scheme to transmit data. The TDMA format contains eight time slots. The handset power amplifier typically transmits in four of these up time slots. To prevent interference between cell phones, the time mask profile as specified is very restricted. To meet the GSM time mask, the output power of the PA needs to ramp up and down very quickly while staying within the time mask and not

generating extraneous frequency bursts due to too abrupt ramp profiles. As described before, the Vramp input value sets the RF output power. By applying a certain ramp profile to the Vramp pin, the power level (Pout) of the PA is set to obtain the required time mask. A time mask of the PA's output power is displayed. The time mask meets the limits (displayed by green lines) over a wide range of temperature, voltage and load variations.

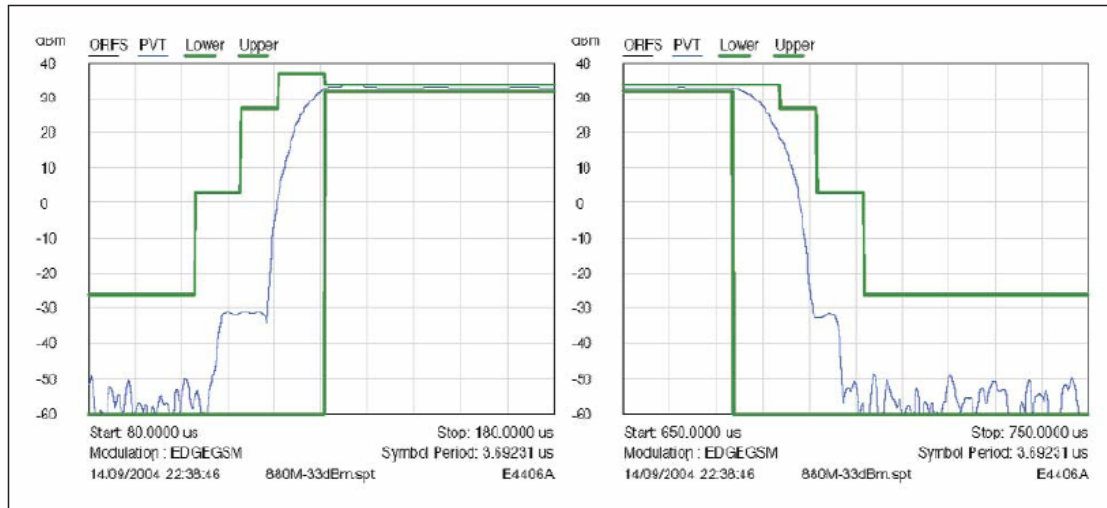

2.2.2 Edge power transmit description

The direct modulation transmitter (8PSK), combined with a low noise GMSK constant envelope modulator or DFM (Direct-Frequency Modulation), delivers high modulation accuracy with exceptionally low noise and eliminates the need for transmit SAW filters in any of the supported GGE bands.

The max Edge power for GSM850 is typically 26.5dBm with the range 26-27.6dBm for MTK;

The max Edge power for PCS is typically 25.5dBm with the range 24-27.0dBm for MTK;

2.3 UMTS Band2 and Band5 transmit max power

Max power range for both band2 and band5 listed as below:

| Nominal Maximum Output Power | | |
|------------------------------|-------------|----------|
| Operating Band | Power (dBm) | Tol (dB) |
| Band2 | 24 | +1/-3 |
| Band5 | 24 | +1/-3 |

Transmitter consists of 5 output ports. TX_LB2 and TX_HB1 ports are multi-mode ports which can support 2G or 3G depending on application circuits on the phone. Typ. maximum TX output power is >0dBm. Overall TX gain dynamic range is 78dB in RF and 8dB in BB. The power detections circuits are also included for better power accuracy over power region of PA gain mode change. In order to ensure power detection accuracy, the PCB trace to DET pin should not be put too close to TX output signal traces.

3 Parameters

F (n) are values coming from the DAC to shape the transmit burst. Some F(n) values have a corresponding Parameter used in the TAT to align the mobiles.

Parameter used in TAT = [F (n)].

3.1 Parameters used to shape the burst

- **H0** = [F (1)] controls the rate at which energy is given to the control loop at the beginning of the ramp. This energy is needed to bring the PA system control in a closed loop. This is the second code coming from the MT8382 DAC.
- **PeakPow** = [F (15)] corresponds to the peak power of the transmit burst.
- **H30** = [F (30)] corresponds to the last ramping coefficients used to shape the ramp.
- **MinPow** = [F (31)] is a fixed parameter and corresponds to the Code Start of the AM7801 specification. It ensures a fast discharge of accumulated energy during the open loop mode in the summing node.

3.2 Parameters used to define the temporal position of the burst

3.2.1 Optimum position of the burst

This parameter is **TRU** (or Δ **TRU_P**) on the panel, in the Optimal Burst. This is the burst starting time correction, which is optimised for each power control level. (Note that **_P** means that the parameter is a power compensation parameter).

3.2.2 Optimum length of the burst

This parameter is **TRD** (or Δ **TRD_P**) on the panel, in the Optimal Burst. This is the burst length compensation, which is optimized for each power control level. (Note that **_P** means that the parameter is a power compensation parameter).

4 Operating mode

4.1 How to transmit a Tch burst (Random data), in PCS1900 mode, at power control level max:

PCS 1900:

Connect the mobile with special software, Configuration of the common parameters:

- Band: PCS1900,
- Channel: 661,
- RF level: 0,
- Burst select: Mode Tch Random

Press STAR command to start continuous TX, you can check the burst with CMU200 or Agilent 8960; it must fit the curve below.

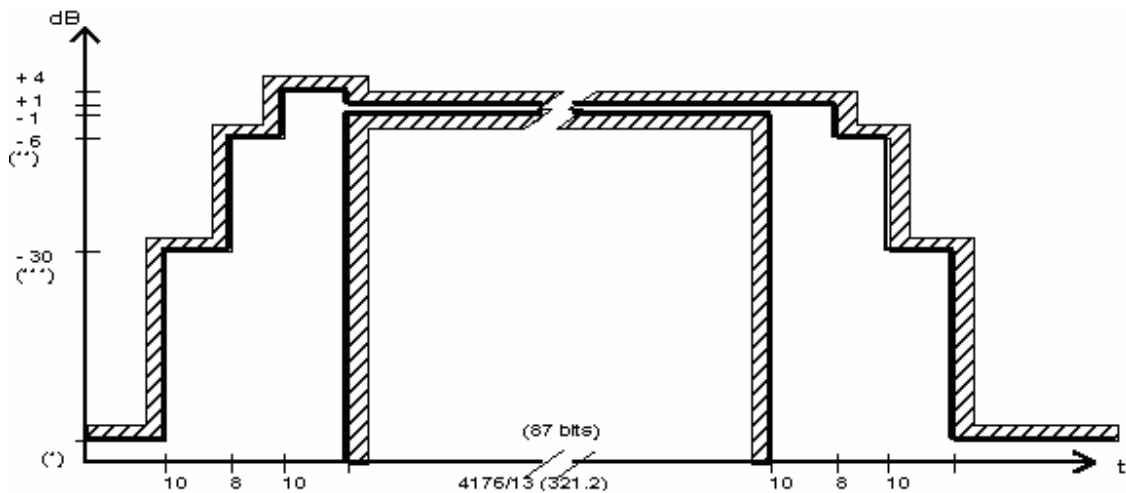

The request of the Power vs. Time.

4.2 How to stop Tx measurements:

Press STOP command to stop the TX.

4.3 How to transmit a burst after modifying parameters

Please note that each time a parameter (such as parameter used to shape the burst) is changed, then the user have to: **download to flash** to validate the parameter modification. If the command is not performed, the old parameters are taken into account.

5 Purpose

This panel gives the description of the Frequency plan.

This window includes both:

- Automatic frequency control (AFC),
- Static frequency error and range,
- Dynamic frequency error and range

6 Automatic frequency control

Before a handset is allowed to transmit any signals, it needs to first receive the FSB signal from the base station, demodulate and decode it using its own local oscillator, map it to the constellation plane, calculate the frequency offset, and adjust the local oscillator accordingly, until 0.1ppm of frequency accuracy is achieved. This frequency correction loop is called the automatic frequency control (AFC) loop in GSM standard.

The process as below:

Automatic frequency control (AFC)

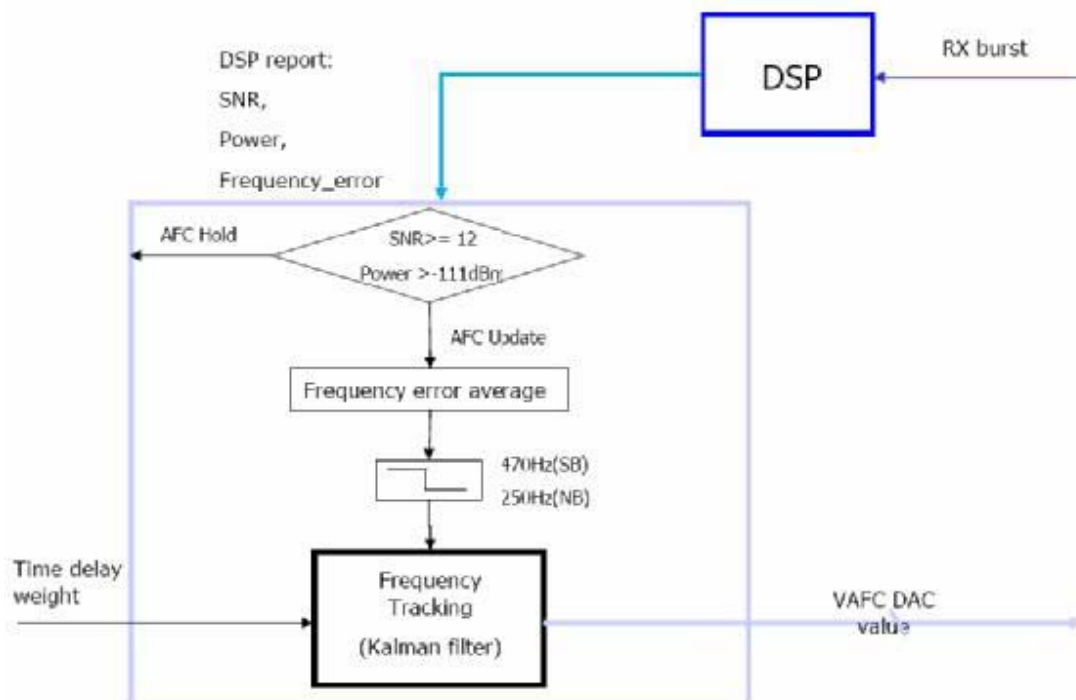

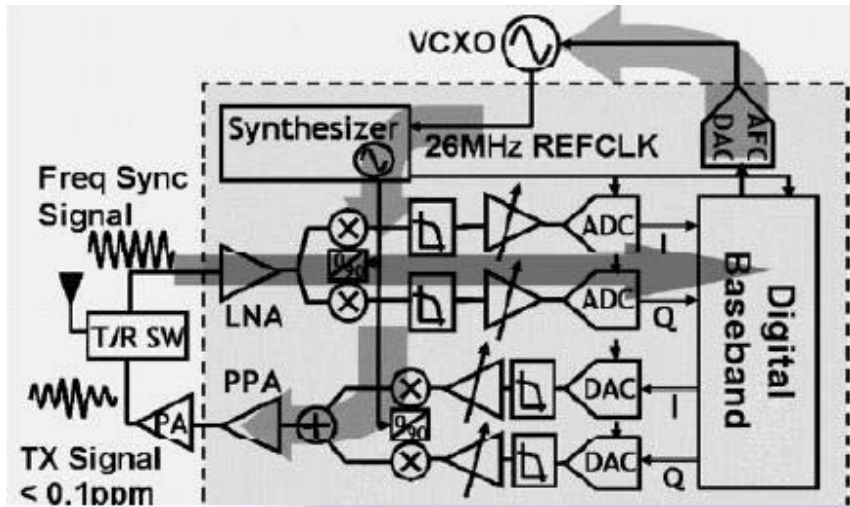

In MT8382 it uses an AFC signal from baseband (DAC) to finish automatic frequency control.

7 Static frequency error and range

- Factors of static frequency error: manufacturing frequency tolerance in crystal at room temperature, aging,
- Static frequency error is compensated for using 6bits programming capacitor array (CAP ID).
- The static frequency range of capacitor array (CAP ID=0 to63) must larger than 34ppm(+-17ppm).
- The static range depends on crystal 's TS and CL
- The capacitor array calibration is done in production testing by setting the AFC DAC to mid-scale(4196) and adjusting CAP ID to the setting that give closest to 0 ppm error(finish by test software). This CAP ID value is then stored in Flash memory and rewritten to MT8382 each time the VCXO is initialized.

Output Power

1. BAND GSM850

Power Level Target Unit Tolerance

| Power level | Power Peak value (dBm) | limit |
|-------------|------------------------|----------|
| 5 | 33 | +/-2 dB) |
| 6 | 31 | +/-3 dB) |
| 7 | 29 | +/-3 dB) |
| 8 | 27 | +/-3 dB) |
| 9 | 25 | +/-3 dB) |
| 10 | 23 | +/-3 dB) |
| 11 | 21 | +/-3 dB) |
| 12 | 19 | +/-3 dB) |
| 13 | 17 | +/-3 dB) |
| 14 | 15 | +/-4 dB) |
| 15 | 13 | +/-4 dB) |
| 16 | 11 | +/-4 dB) |
| 17 | 9 | +/-4 dB) |
| 18 | 7 | +/-5 dB) |
| 19 | 5 | +/-5 dB) |

2. BAND PCS1900

Power Level Target Unit Tolerance

| Power level | Power Peak value dBm | limit |
|-------------|-------------------------|---------------|
| | | normal |
| 0 | 30 | +/-2 dB) |
| 1 | 28 | +/-3 dB) |
| 2 | 26 | +/-3 dB) |
| 3 | 24 | +/-3 dB) |
| 4 | 22 | +/-3 dB) |
| 5 | 20 | +/-3 dB) |
| 6 | 18 | +/-3 dB) |
| 7 | 16 | +/-3 dB) |
| 8 | 14 | +/-3 dB) |
| 9 | 12 | +/-4 dB) |
| 10 | 10 | +/-4 dB) |
| 11 | 8 | +/-4 dB) |
| 12 | 6 | +/-4 dB) |
| 13 | 4 | +/-4 dB) |
| 14 | 2 | +/-5 dB) |
| 15 | 0 | +/-5 dB) |

3. GPRS Output Power

GSM850&PCS1900 allowed maximum output reduction in a multislot Configuration

| Number of Timeslots in uplink assignment | Permissible nominal reduction of maximum output Power,(dB) |
|--|--|
| 1 | 0 |
| 2 | 0 to 3,0 |
| 3 | 1,8 to 4,8 |
| 4 | 3,0 to 6,0 |

4. BAND WCDMA850& WCDMA1900

| Band | Power level | Power Peak value (dBm) | limit |
|-----------|-------------|------------------------|----------|
| WCDMA850 | Max Power | 22.66 | +1/-3 dB |
| WCDMA1900 | Max Power | 22.43 | +1/-3 dB |