



## TEST REPORT

BNetzA-CAB-02/21-102

Test report no.: 1-1599/20-02-02

### Testing laboratory

**CTC advanced GmbH**

Untertuerkheimer Strasse 6 – 10  
66117 Saarbruecken / Germany  
Phone: + 49 681 5 98 - 0  
Fax: + 49 681 5 98 - 9075  
Internet: <https://www.ctcadvanced.com>  
e-mail: [mail@ctcadvanced.com](mailto:mail@ctcadvanced.com)

**Accredited Testing Laboratory:**

The testing laboratory (area of testing) is accredited according to DIN EN ISO/IEC 17025 (2018-03) by the Deutsche Akkreditierungsstelle GmbH (DAkkS)  
The accreditation is valid for the scope of testing procedures as stated in the accreditation certificate starting with the registration number: D-PL-12076-01.

### Applicant

**B.E.A. s.a.**

LIEGE Science Park  
Allée des Noisetiers, 5  
4031 Angleur / BELGIUM  
Phone: +32 43 61 65 65  
Contact: Jean-Pierre LERUTH  
e-mail: [Jean-Pierre.LERUTH@bea.be](mailto:Jean-Pierre.LERUTH@bea.be)

### Manufacturer

**B.E.A. s.a.**  
LIEGE Science Park  
Allée des Noisetiers, 5  
4031 Angleur / BELGIUM

### Test standard/s

47 CFR Part 15 Title 47 of the Code of Federal Regulations; Chapter I; Part 15 - Radio frequency devices  
RSS - 210 Issue 10 Radio Standards Specification - Licence-Exempt Radio Apparatus: Category II Equipment

For further applied test standards please refer to section 3 of this test report.

### Test Item

**Kind of test item:** 24 GHz Radar  
**Model name:** DRO BEA-T4  
**FCC ID:** G9B-100606  
**IC:** 4680A-100606  
**Frequency:** 24.075 GHz – 24.175 GHz  
**Antenna:** Integrated patch antenna  
**Power supply:** 5.5 V to 6 V DC by external power supply  
**Temperature range:** -30°C to +70°C

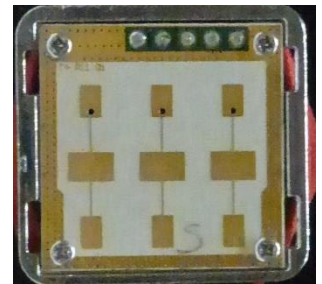

This test report is electronically signed and valid without handwritten signature. For verification of the electronic signatures, the public keys can be requested at the testing laboratory.

### Test report authorized:

Meheza Walla  
Lab Manager  
Radio Communications

### Test performed:

p.o.  
Sebastian Janoschka  
Lab Manager  
Radio Communications

## 1 Table of contents

1	Table of contents .....	2
2	General information .....	3
2.1	Notes and disclaimer .....	3
2.2	Application details.....	3
2.3	Test laboratories sub-contracted .....	3
3	Test standard/s and references .....	4
4	Test environment.....	4
5	Reporting statements of conformity – decision rule .....	5
6	Test item .....	6
6.1	General description .....	6
6.2	Additional information .....	6
7	Description of the test setup .....	7
7.1	Shielded semi anechoic chamber .....	8
7.2	Shielded fully anechoic chamber .....	10
7.3	Radiated measurements > 18 GHz.....	12
7.4	Radiated measurements > 50/85 GHz.....	12
8	Measurement uncertainty .....	14
9	Sequence of testing .....	15
9.1	Sequence of testing radiated spurious 9 kHz to 30 MHz.....	15
9.2	Sequence of testing radiated spurious 30 MHz to 1 GHz .....	16
9.3	Sequence of testing radiated spurious 1 GHz to 18 GHz .....	17
9.4	Sequence of testing radiated spurious above 18 GHz .....	18
9.5	Sequence of testing radiated spurious above 50/85 GHz with external mixers .....	19
10	Summary of measurement results.....	20
11	Measurement results .....	21
11.1	Field strength of fundamental emission.....	21
11.2	Occupied bandwidth.....	24
11.3	Field strength of emissions (radiated spurious) .....	26
11.4	Frequency Stability .....	35
Annex A	Glossary.....	45
Annex B	Document history .....	46
Annex C	Accreditation Certificate .....	46

## 2 General information

### 2.1 Notes and disclaimer

The test results of this test report relate exclusively to the test item specified in this test report. CTC advanced GmbH does not assume responsibility for any conclusions and generalizations drawn from the test results with regard to other specimens or samples of the type of the equipment represented by the test item.

The test report may only be reproduced or published in full. Reproduction or publication of extracts from the report requires the prior written approval of CTC advanced GmbH.

The testing service provided by CTC advanced GmbH has been rendered under the current "General Terms and Conditions for CTC advanced GmbH".

CTC advanced GmbH will not be liable for any loss or damage resulting from false, inaccurate, inappropriate or incomplete product information provided by the customer.

Under no circumstances does the CTC advanced GmbH test report include any endorsement or warranty regarding the functionality, quality or performance of any other product or service provided.

Under no circumstances does the CTC advanced GmbH test report include or imply any product or service warranties from CTC advanced GmbH, including, without limitation, any implied warranties of merchantability, fitness for purpose, or non-infringement, all of which are expressly disclaimed by CTC advanced GmbH.

All rights and remedies regarding vendor's products and services for which CTC advanced GmbH has prepared this test report shall be provided by the party offering such products or services and not by CTC advanced GmbH. In no case this test report can be considered as a Letter of Approval.

This test report is electronically signed and valid without handwritten signature. For verification of the electronic signatures, the public keys can be requested at the testing laboratory.

### 2.2 Application details

Date of receipt of order:	2020-12-11
Date of receipt of test item:	2020-12-15
Start of test:*	2020-12-16
End of test:*	2020-12-21
Person(s) present during the test:	-/-

\*Date of each measurement, if not shown in the plot, can be requested. Dates are stored in the measurement software.

### 2.3 Test laboratories sub-contracted

None

### 3 Test standard/s and references

Test standard	Date	Description
47 CFR Part 15	12-2020	Title 47 of the Code of Federal Regulations; Chapter I; Part 15 - Radio frequency devices
RSS - 210 Issue 10	12-2019	Radio Standards Specification - Licence-Exempt Radio Apparatus: Category II Equipment
RSS-GEN	03-2019	General Requirements for Compliance of Radio Apparatus

Guidance	Version	Description
ANSI C63.4-2014	-/-	American national standard for methods of measurement of radio-noise emissions from low-voltage electrical and electronic equipment in the range of 9 kHz to 40 GHz
ANSI C63.10-2013	-/-	American national standard of procedures for compliance testing of unlicensed wireless devices

### 4 Test environment

Temperature	:	$T_{nom}$ $T_{max}$ $T_{min}$	+20 °C during room temperature tests +50 °C during high temperature tests -20 °C during low temperature tests
Relative humidity content	:		45 %
Barometric pressure	:		1019 hPa
Power supply	:	$V_{nom}$ $V_{max}$ $V_{min}$	5.5 V DC by external power supply 6.0 V 5.5 $V_{min}$ declared by customer

## 5 Reporting statements of conformity – decision rule

Only the measured values related to their corresponding limits will be used to decide whether the equipment under test meets the requirements of the test standards listed in chapter 3. The measurement uncertainty is mentioned in this test report, see chapter 8, but is not taken into account - neither to the limits nor to the measurement results. Measurement results with a smaller margin to the corresponding limits than the measurement uncertainty have a potential risk of more than 5% that the decision might be wrong.

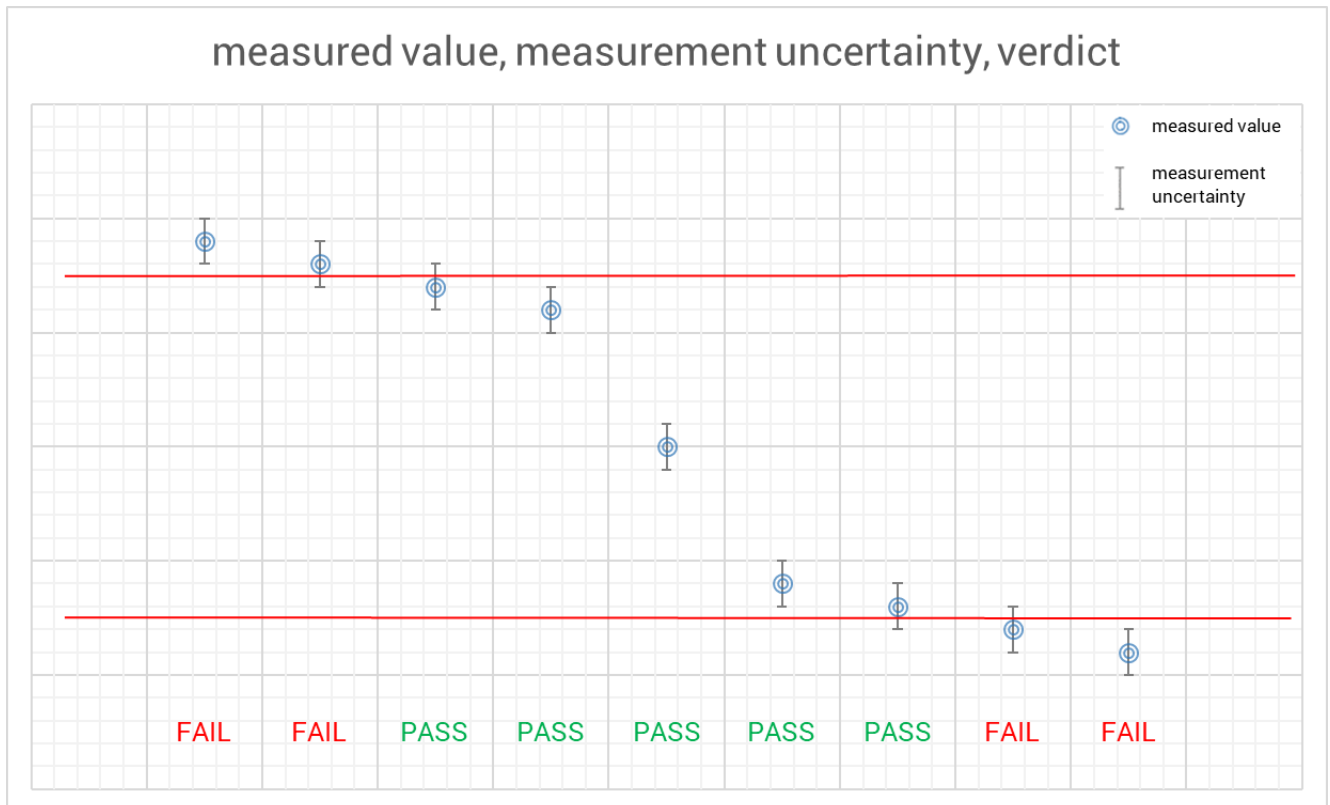

## 6 Test item

### 6.1 General description

Kind of test item	:	24 GHz Radar
Type identification	:	DRO BEA-T4
S/N serial number	:	5
HVIN	:	DRO BEA-T4
PMN	:	DRO BEA-T4
FVIN	:	-/-
HMN	:	-/-
HW hardware status	:	10.0606 (Ready for mass production)
SW software status	:	N/A
Frequency band	:	24.075 GHz – 24.175 GHz
Type of modulation	:	CW
Number of channels	:	1
Number of modes	:	1
Antenna	:	Integrated patch antenna
Power supply	:	5.5 V to 6 V DC by external power supply
Temperature range	:	-30°C to +70°C

### 6.2 Additional information

The content of the following annexes is defined in the QA. It may be that not all of the listed annexes are necessary for this report, thus some values in between may be missing.

Test setup- and EUT-photos are included in test report:

- 1-1599/20-02-01\_AnnexA
- 1-1599/20-02-01\_AnnexB
- 1-1599/20-02-01\_AnnexD

## 7 Description of the test setup

Typically, the calibrations of the test apparatus are commissioned to and performed by an accredited calibration laboratory. The calibration intervals are determined in accordance with the DIN EN ISO/IEC 17025. In addition to the external calibrations, the laboratory executes comparison measurements with other calibrated test systems or effective verifications. Weekly chamber inspections and range calibrations are performed. Where possible, RF generating and signaling equipment as well as measuring receivers and analyzers are connected to an external high-precision 10 MHz reference (GPS-based or rubidium frequency standard).

In order to simplify the identification of the equipment used at some special tests, some items of test equipment and ancillaries can be provided with an identifier or number in the equipment list below (Lab/Item).

### **Agenda:** Kind of Calibration

k	calibration / calibrated		EK	limited calibration
ne	not required (k, ev, izw, zw not required)		zw	cyclical maintenance (external cyclical maintenance)
ev	periodic self verification		izw	internal cyclical maintenance
Ve	long-term stability recognized		g	blocked for accredited testing
vkl!	Attention: extended calibration interval			
NK!	Attention: not calibrated		*)	next calibration ordered / currently in progress

## 7.1 Shielded semi anechoic chamber

The radiated measurements are performed in vertical and horizontal plane in the frequency range from 30 MHz to 1 GHz in semi-anechoic chambers. The EUT is positioned on a non-conductive support with a height of 0.80 m above a conductive ground plane that covers the whole chamber. The receiving antennas are conform to specifications ANSI C63. These antennas can be moved over the height range between 1.0 m and 4.0 m in order to search for maximum field strength emitted from EUT. The measurement distances between EUT and receiving antennas are indicated in the test setups for the various frequency ranges. For each measurement, the EUT is rotated in all three axes until the maximum field strength is received. The wanted and unwanted emissions are received by spectrum analyzers where the detector modes and resolution bandwidths over various frequency ranges are set according to requirement ANSI C63.

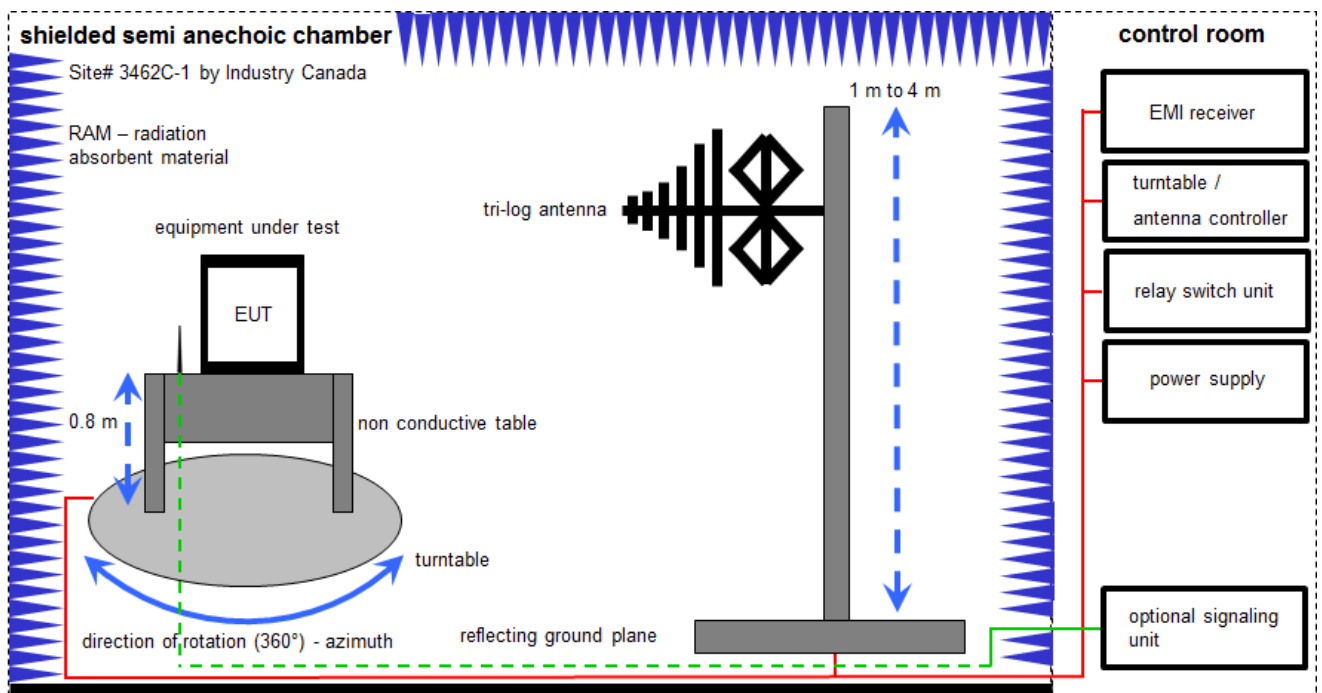

Measurement distance: tri-log antenna 10 meter

$$FS = UR + CL + AF$$

(FS-field strength; UR-voltage at the receiver; CL-loss of the cable; AF-antenna factor)

Example calculation:

$$FS [dB\mu V/m] = 12.35 [dB\mu V/m] + 1.90 [dB] + 16.80 [dB/m] = 31.05 [dB\mu V/m] (35.69 \mu V/m)$$



**Equipment table:**

No.	Lab / Item	Equipment	Type	Manufacturer	Serial No.	INV. No.	Kind of Calibration	Last Calibration	Next Calibration
1	45	Switch-Unit	3488A	HP	2719A14505	300000368	ev	-/-	-/-
2	50	DC power supply, 60Vdc, 50A, 1200 W	6032A	HP	2920A04466	300000580	ne	-/-	-/-
3	93	Meißkabine 1	HF-Absorberhalle	MWB AG 300023		300000551	ne	-/-	-/-
4	n. a.	Antenna Tower	Model 2175	ETS-Lindgren	64762	300003745	izw	-/-	-/-
5	n. a.	Positioning Controller	Model 2090	ETS-Lindgren	64672	300003746	izw	-/-	-/-
6	n. a.	TRILOG Broadband Test-Antenna 30 MHz - 3 GHz	VULB9163	Schwarzbeck Mess - Elektronik	295	300003787	vKI!	19.02.2019	18.02.2021
7	n. a.	EMI Test Receiver	ESR3	Rohde & Schwarz	102587	300005771	k	10.12.2020	09.06.2022
8	n. a.	Analyzer-Reference-System (Harmonics and Flicker)	ARS 16/1	SPS	A3509 07/0 0205	300003314	vKI!	17.01.2020	16.01.2022
9	n. a.	Turntable Interface-Box	Model 105637	ETS-Lindgren	44583	300003747	izw	-/-	-/-

## 7.2 Shielded fully anechoic chamber

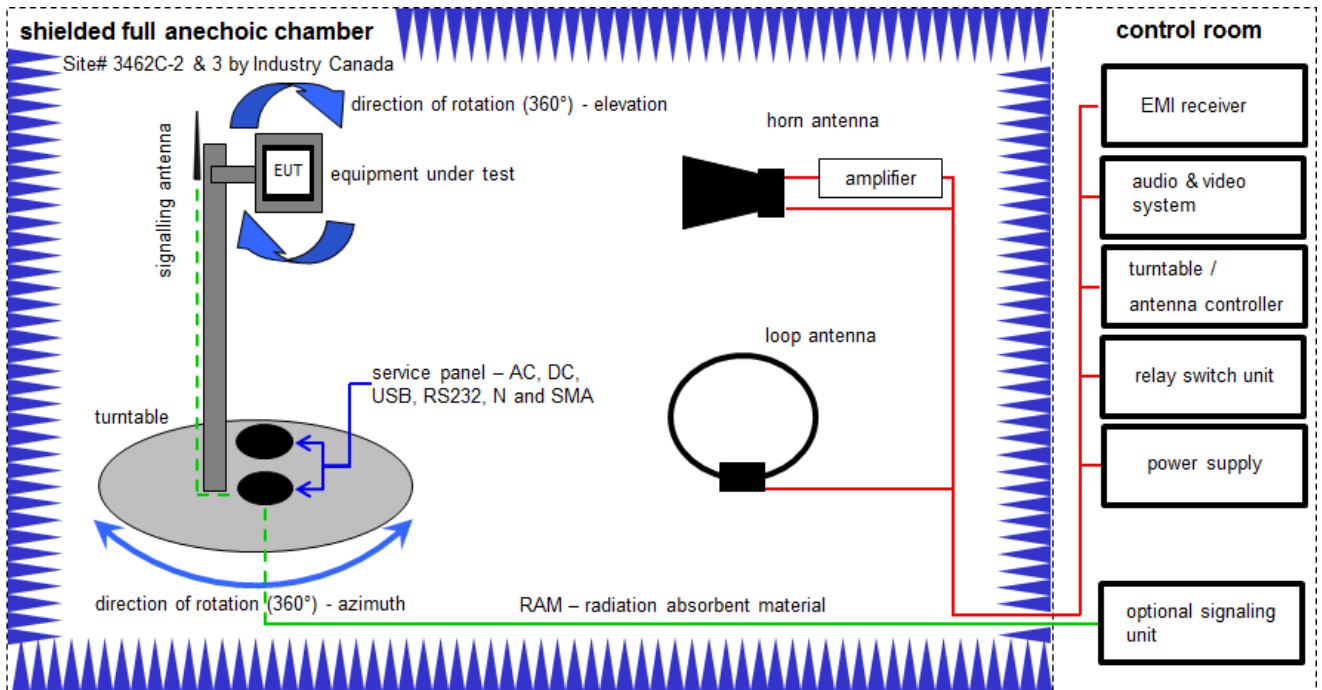

Measurement distance: horn antenna 3 meter; loop antenna 3 meter / 1 meter

$$FS = UR + CA + AF$$

(FS-field strength; UR-voltage at the receiver; CA-loss of the signal path; AF-antenna factor)

Example calculation:

$$FS [dB\mu V/m] = 40.0 [dB\mu V/m] + (-35.8) [dB] + 32.9 [dB/m] = 37.1 [dB\mu V/m] (71.61 \mu V/m)$$

$$OP = AV + D - G + CA$$

(OP-radiated output power; AV-analyzer value; D-free field attenuation of measurement distance; G-antenna gain+amplifier gain; CA-loss signal path)

Example calculation:

$$OP [dBm] = -39.0 [dBm] + 57.0 [dB] - 12.0 [dBi] + (-36.0) [dB] = -30 [dBm] (1 \mu W)$$

**Equipment table:**

No.	Lab / Item	Equipment	Type	Manufacturer	Serial No.	INV. No.	Kind of Calibration	Last Calibration	Next Calibration
1	A,B,C	DC power supply, 60Vdc, 50A, 1200 W	6032A	HP	2818A03450	300001040	vKI!	09.12.2020	08.12.2023
2	A,B,C	Anechoic chamber	FAC 3/5m	MWB / TDK	87400/02	300000996	ev	-/-	-/-
3	B	Double-Ridged Waveguide Horn Antenna 1-18.0GHz	3115	EMCO	9107-3697	300001605	vKI!	27.12.2019	26.02.2021
4	A,B,C	Switch / Control Unit	3488A	HP	*	300000199	ne	-/-	-/-
5	A,B,C	Variable isolating transformer	MPL IEC625 Bus Variable isolating transformer	Erfi	91350	300001155	ne	-/-	-/-
6	A,B,C	EMI Test Receiver 20Hz- 26,5GHz	ESU26	R&S	100037	300003555	k	11.12.2020	10.12.2021
7	B	Highpass Filter	WHKX7.0/18G-8SS	Wainwright	19	300003790	ne	-/-	-/-
8	B	Broadband Amplifier 0.5-18 GHz	CBLU5184540	CERNEX	22049	300004481	ev	-/-	-/-
9	B	Broadband Amplifier 5-13 GHz	CBLU5135235	CERNEX	22010	300004491	ev	-/-	-/-
10	A,B,C	4U RF Switch Platform	L4491A	Agilent Technologies	MY50000037	300004509	ne	-/-	-/-
11	A,B,C	NEXIO EMV-Software	BAT EMC V3.16.0.49	EMCO		300004682	ne	-/-	-/-
12	A,B,C	PC	ExOne	F+W		300004703	ne	-/-	-/-
13	B	RF-Amplifier	AMF-6F06001800-30-10P-R	NARDA-MITEQ Inc	2011572	300005241	ev	-/-	-/-
14	n. a.	Active Loop Antenna 9 kHz to 30 MHz	6502	EMCO	2210	300001015	vKI!	13.06.2019	12.06.2021

### 7.3 Radiated measurements > 18 GHz

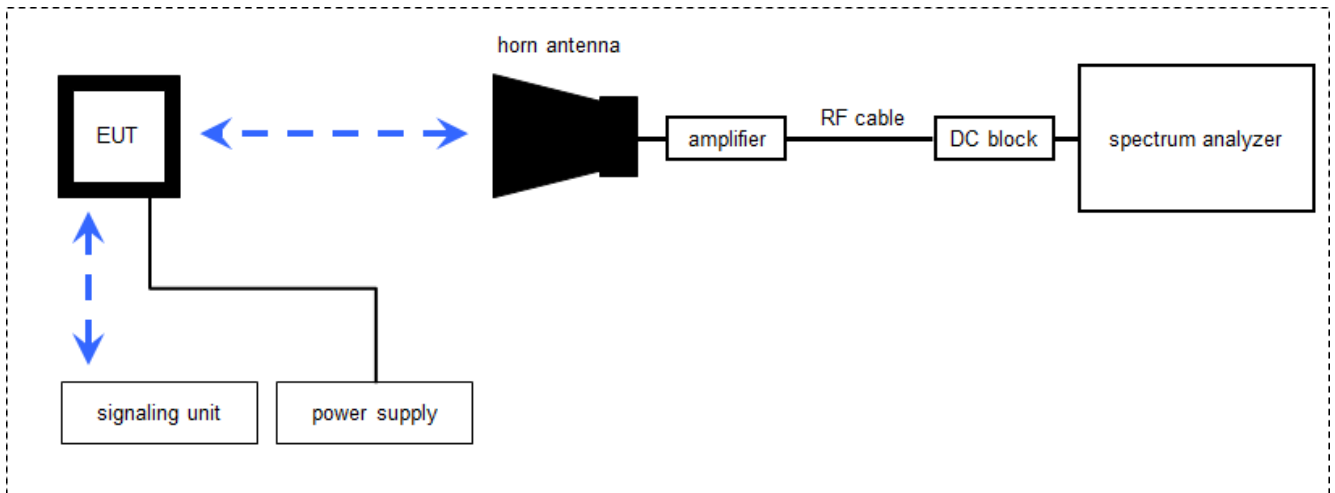

### 7.4 Radiated measurements > 50/85 GHz

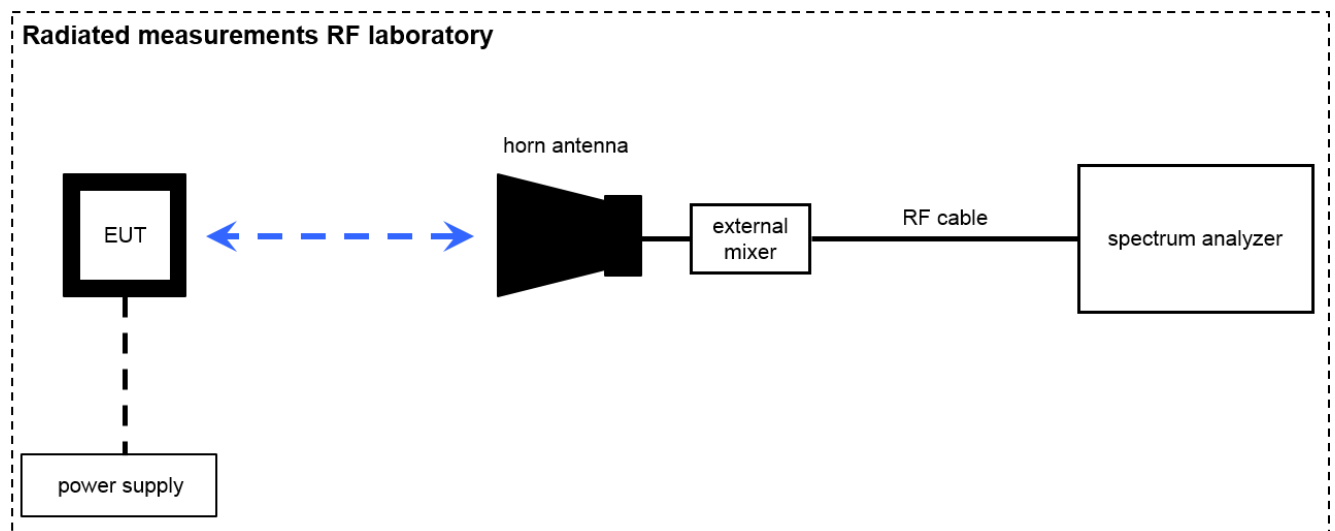

Measurement distance: horn antenna e.g. 25 cm

$$FS = UR + CA + AF$$

(FS-field strength; UR-voltage at the receiver; CA-loss signal path & distance correction; AF-antenna factor)

Example calculation:

$$FS [dB\mu V/m] = 40.0 [dB\mu V/m] + (-60.1) [dB] + 36.74 [dB/m] = 16.64 [dB\mu V/m] (6.79 \mu V/m)$$

$$OP = AV + D - G + CA$$

(OP-radiated output power; AV-analyzer value; D-free field attenuation of measurement distance; G-antenna gain+amplifier gain; CA-loss signal path)

Example calculation:

$$OP [dBm] = -59.0 [dBm] + 44.0 [dB] - 20.0 [dBi] + 5.0 [dB] = -30 [dBm] (1 \mu W)$$

**Equipment table:**

No.	Lab / Item	Equipment	Type	Manufacturer	Serial No.	INV. No.	Kind of Calibration	Last Calibration	Next Calibration
1	n. a.	Spectrum Analyzer	FSW50	Rohde & Schwarz	101332	300005935	k	26.02.2020	25.02.2021
2	n. a.	Broadband LNA 18-50 GHz	CBL18503070PN	CERNEX	25240	300004948	ev	09.03.2020	08.03.2022
3	n.a.	Horn Antenna 18,0-40,0 GHz	LHAF180	Microw.Devel	39180-103-021	300001747	vKI!	18.02.2019	17.02.2022
4	A027	Std. Gain Horn Antenna 18.0-26.5 GHz	638	Narda	01096	300000486	vKI!	21.01.2020	20.01.2022
5	A031	Std. Gain Horn Antenna 26.5-40.0 GHz	V637	Narda	82-16	300000510	vKI!	23.01.2020	22.01.2022
6	n. a.	Std. Gain Horn Antenna 33.0-50.1 GHz	2324-20	Flann	57	400000683	ne	-/-	-/-
7	n. a.	Harmonic Mixer 3-Port, 50-75 GHz	FS-Z75	Rohde & Schwarz	101578	300005788	k	17.06.2020	16.06.2021
8	A026	Std. Gain Horn Antenna 49.9-75.8 GHz	2524-20	Flann	*	300001986	ne	-/-	-/-
9	n. a.	Harmonic Mixer 3-Port, 75-110 GHz	FS-Z110	R&S	101411	300004959	k	19.06.2020	18.06.2021
10	A027	Std. Gain Horn Antenna 73.8-112 GHz	2724-20	Flann	*	300001988	ne	-/-	-/-

## 8 Measurement uncertainty

Test case	Uncertainty
Equivalent isotropically radiated power (e.i.r.p.)	Conducted value $\pm 1$ dB Radiated value $\pm 3$ dB
Permitted range of operating frequencies	$\pm 100$ kHz
Conducted unwanted emissions in the spurious domain (up to 18 GHz)	$\pm 1$ dB
Radiated unwanted emissions in the spurious domain (up to 18 GHz)	$\pm 3$ dB
Conducted unwanted emissions in the spurious domain (18 to 40 GHz)	$\pm 4$ dB
Radiated unwanted emissions in the spurious domain (18 to 40 GHz)	$\pm 4$ dB
Conducted unwanted emissions in the spurious domain (40 to 50 GHz)	$\pm 4.5$ dB
Radiated unwanted emissions in the spurious domain (40 to 50 GHz)	$\pm 4.5$ dB
Conducted unwanted emissions in the spurious domain (above 50 GHz)	$\pm 5$ dB
Radiated unwanted emissions in the spurious domain (above 50 GHz)	$\pm 5$ dB
DC and low frequency voltages	$\pm 3$ %
Temperature	$\pm 1$ °C
Humidity	$\pm 3$ %

## 9 Sequence of testing

### 9.1 Sequence of testing radiated spurious 9 kHz to 30 MHz

#### Setup

- The equipment is set up to simulate normal operation mode as described in the user manual or defined by the manufacturer.
- If the EUT is a tabletop system, it is placed on a table with 0.8 m height.
- If the EUT is a floor standing device, it is placed directly on the turn table.
- Auxiliary equipment and cables are positioned to simulate normal operation conditions as described in ANSI C 63.4.
- The AC power port of the EUT (if available) is connected to a power outlet below the turntable.
- Measurement distance is 3 m (see ANSI C 63.4) – see test details.
- EUT is set into operation.

#### Premeasurement\*

- The turntable rotates from 0° to 315° using 45° steps.
- The antenna height is 1 m.
- At each turntable position the analyzer sweeps with positive-peak detector to find the maximum of all emissions.

#### Final measurement

- Identified emissions during the pre-measurement are maximized by the software by rotating the turntable from 0° to 360°.
- Loop antenna is rotated about its vertical axis for maximum response at each azimuth about the EUT. (For certain applications, the loop antenna plane may also need to be positioned horizontally at the specified distance from the EUT)
- The final measurement is done in the position (turntable and elevation) causing the highest emissions with quasi-peak (as described in ANSI C 63.4).
- Final levels, frequency, measuring time, bandwidth, turntable position, correction factor, margin to the limit and limit will be recorded. A plot with the graph of the premeasurement and the limit is stored.

\*)Note: The sequence will be repeated three times with different EUT orientations.

## 9.2 Sequence of testing radiated spurious 30 MHz to 1 GHz

### Setup

- The equipment is set up to simulate normal operation mode as described in the user manual or defined by the manufacturer.
- If the EUT is a tabletop system, a table with 0.8 m height is used, which is placed on the ground plane.
- If the EUT is a floor standing device, it is placed on the ground plane with insulation between both.
- Auxiliary equipment and cables are positioned to simulate normal operation conditions as described in ANSI C 63.4.
- The AC power port of the EUT (if available) is connected to a power outlet below the turntable.
- Measurement distance is 10 m or 3 m (see ANSI C 63.4) – see test details.
- EUT is set into operation.

### Premeasurement

- The turntable rotates from 0° to 315° using 45° steps.
- The antenna is polarized vertical and horizontal.
- The antenna height changes from 1 m to 3 m.
- At each turntable position, antenna polarization and height the analyzer sweeps three times in peak to find the maximum of all emissions.

### Final measurement

- The final measurement is performed for at least six highest peaks according to the requirements of the ANSI C63.4.
- Based on antenna and turntable positions at which the peak values are measured the software maximize the peaks by changing turntable position  $\pm 45^\circ$  and antenna height between 1 and 4 m.
- The final measurement is done with quasi-peak detector (as described in ANSI C 63.4).
- Final levels, frequency, measuring time, bandwidth, antenna height, antenna polarization, turntable angle, correction factor, margin to the limit and limit are recorded. A plot with the graph of the premeasurement with marked maximum final results and the limit is stored.



### 9.3 Sequence of testing radiated spurious 1 GHz to 18 GHz

#### Setup

- The equipment is set up to simulate normal operation mode as described in the user manual or defined by the manufacturer.
- If the EUT is a tabletop system, a 2-axis positioner with 1.5 m height is used.
- If the EUT is a floor standing device, it is placed directly on the turn table.
- Auxiliary equipment and cables are positioned to simulate normal operation conditions as described in ANSI C 63.4.
- The AC power port of the EUT (if available) is connected to a power outlet below the turntable.
- Measurement distance is 3 m (see ANSI C 63.4) – see test details.
- EUT is set into operation.

#### Premeasurement

- The turntable rotates from 0° to 315° using 45° steps.
- The antenna is polarized vertical and horizontal.
- The antenna height is 1.5 m.
- At each turntable position and antenna polarization the analyzer sweeps with positive peak detector to find the maximum of all emissions.

#### Final measurement

- The final measurement is performed for at least six highest peaks according to the requirements of the ANSI C63.4.
- Based on antenna and turntable positions at which the peak values are measured the software maximizes the peaks by rotating the turntable from 0° to 360°. This measurement is repeated for different EUT-table positions (0° to 150° in 30°-steps) and for both antenna polarizations.
- The final measurement is done in the position (turntable, EUT-table and antenna polarization) causing the highest emissions with Peak and RMS detector (as described in ANSI C 63.4).
- Final levels, frequency, measuring time, bandwidth, turntable position, EUT-table position, antenna polarization, correction factor, margin to the limit and limit are recorded. A plot with the graph of the premeasurement with marked maximum final results and the limit is stored.

## 9.4 Sequence of testing radiated spurious above 18 GHz

### Setup

- The equipment is set up to simulate normal operation mode as described in the user manual or defined by the manufacturer.
- Auxiliary equipment and cables are positioned to simulate normal operation conditions as described in ANSI C 63.4.
- The AC power port of the EUT (if available) is connected to a power outlet.
- The measurement distance is as appropriate (e.g. 0.5 m).
- The EUT is set into operation.

### Premeasurement

- The test antenna is handheld and moved carefully over the EUT to cover the EUT's whole sphere and different polarizations of the antenna.

### Final measurement

- The final measurement is performed at the position and antenna orientation causing the highest emissions with Peak and RMS detector (as described in ANSI C 63.4).
- Final levels, frequency, measuring time, bandwidth, correction factor, margin to the limit and limit are recorded. A plot with the graph of the premeasurement and the limit is stored.

## 9.5 Sequence of testing radiated spurious above 50/85 GHz with external mixers

### Setup

- The equipment is set up to simulate normal operation mode as described in the user manual or defined by the manufacturer.
- Auxiliary equipment and cables are positioned to simulate normal operation conditions as described in ANSI C 63.4.
- The AC power port of the EUT (if available) is connected to a power outlet.
- The measurement distance is as appropriate for far field (e.g. 0.25 m).
- The EUT is set into operation.

### Premeasurement

- The test antenna with external mixer is handheld and moved carefully over the EUT to cover the EUT's whole sphere and different polarizations of the antenna.
- Caution is taken to reduce the possible overloading of the external mixer.

### Final measurement

- The final measurement is performed at the position and antenna orientation causing the highest emissions with Peak and RMS detector (as described in ANSI C 63.4).
- As external mixers may generate false images care is taken to ensure that any emission measured by the spectrum analyzer does indeed originate in the EUT. Signal identification feature of spectrum analyzer is used to eliminate false mixer images (i.e., it is not the fundamental emission or a harmonic falling precisely at the measured frequency).
- Final levels, frequency, measuring time, bandwidth, correction factor, margin to the limit and limit are recorded. A plot with the graph of the premeasurement and the limit is stored.

## 10 Summary of measurement results

<input checked="" type="checkbox"/>	<b>No deviations from the technical specifications were ascertained</b>
<input type="checkbox"/>	There were deviations from the technical specifications ascertained
<input type="checkbox"/>	This test report is only a partial test report. The content and verdict of the performed test cases are listed below.

TC Identifier	Description	Verdict	Date	Remark
RF-Testing	FCC 47 CFR Part 15 RSS-210 Issue 10	Passed	2020-12-22	-/-

Test specification clause	Test case	Temperature conditions	Power source voltages	C	NC	NA	NP	Results (max.)
§15.245(b) / RSS-210, F.1(a)	Field strength of fundamental emission	Nominal	Nominal	<input checked="" type="checkbox"/>	<input type="checkbox"/>	<input type="checkbox"/>	<input type="checkbox"/>	
§2.1049	Occupied bandwidth (99% bandwidth)	Nominal	Nominal	<input checked="" type="checkbox"/>	<input type="checkbox"/>	<input type="checkbox"/>	<input type="checkbox"/>	
§15.209(a) / §15.245(b) / RSS-210, F.1	Field strength of emissions (radiated spurious)	Nominal	Nominal	<input checked="" type="checkbox"/>	<input type="checkbox"/>	<input type="checkbox"/>	<input type="checkbox"/>	
§15.207(a) RSS-Gen 8.8	Conducted emissions < 30 MHz	Nominal	Nominal	<input type="checkbox"/>	<input type="checkbox"/>	<input checked="" type="checkbox"/>	<input type="checkbox"/>	
§15.215(c) RSS-Gen 8.11	Frequency Stability	Nominal Extreme	Nominal Extreme	<input checked="" type="checkbox"/>	<input type="checkbox"/>	<input type="checkbox"/>	<input type="checkbox"/>	

**Note:** C = Compliant; NC = Not compliant; NA = Not applicable; NP = Not performed

## 11 Measurement results

### 11.1 Field strength of fundamental emission

#### Description:

Measurement of the maximum radiated field strength of the wanted signal.

#### Measurement:

Measurement parameter	
Detector:	Pos-Peak / Average
Sweep time:	10 s
Resolution bandwidth:	1 MHz
Video bandwidth:	3 MHz
Span:	150 MHz
Trace-Mode:	Max Hold
Measurement uncertainty	± 3 dB

This test was performed on a shorter test distance. A correction factor of  $20 \cdot \log(x \text{ m}/3 \text{ m})$  is already considered in the plots.

#### Limits:

FCC		IC
CFR Part 15.245(b)		RSS-210, F.1
Field strength of emissions		
The field strength of emissions from intentional radiators operated within these frequency bands shall comply with the following:		
Frequency	Field Strength	Measurement distance
24.075 GHz – 24.175 GHz	128 dB $\mu$ V/m (Average) 148 dB $\mu$ V/m (PEAK)	3 m

§15.245 (b) (4) The emission limits shown above are based on measurement instrumentation employing an average detector. The provisions in §15.35 for limiting peak emissions apply

§15.31 (c) Except as otherwise indicated in §15.256, for swept frequency equipment, measurements shall be made with the frequency sweep stopped at those frequencies chosen for the measurements to be reported.

**Measurement results:**

Test condition	Maximum field strength (Peak) (dB $\mu$ V/m @3m)	Maximum field strength (Average) (dB $\mu$ V/m @3m)
Nominal	112.97	112.83

**Note:**

-/-

Plot No. 1: Field strength

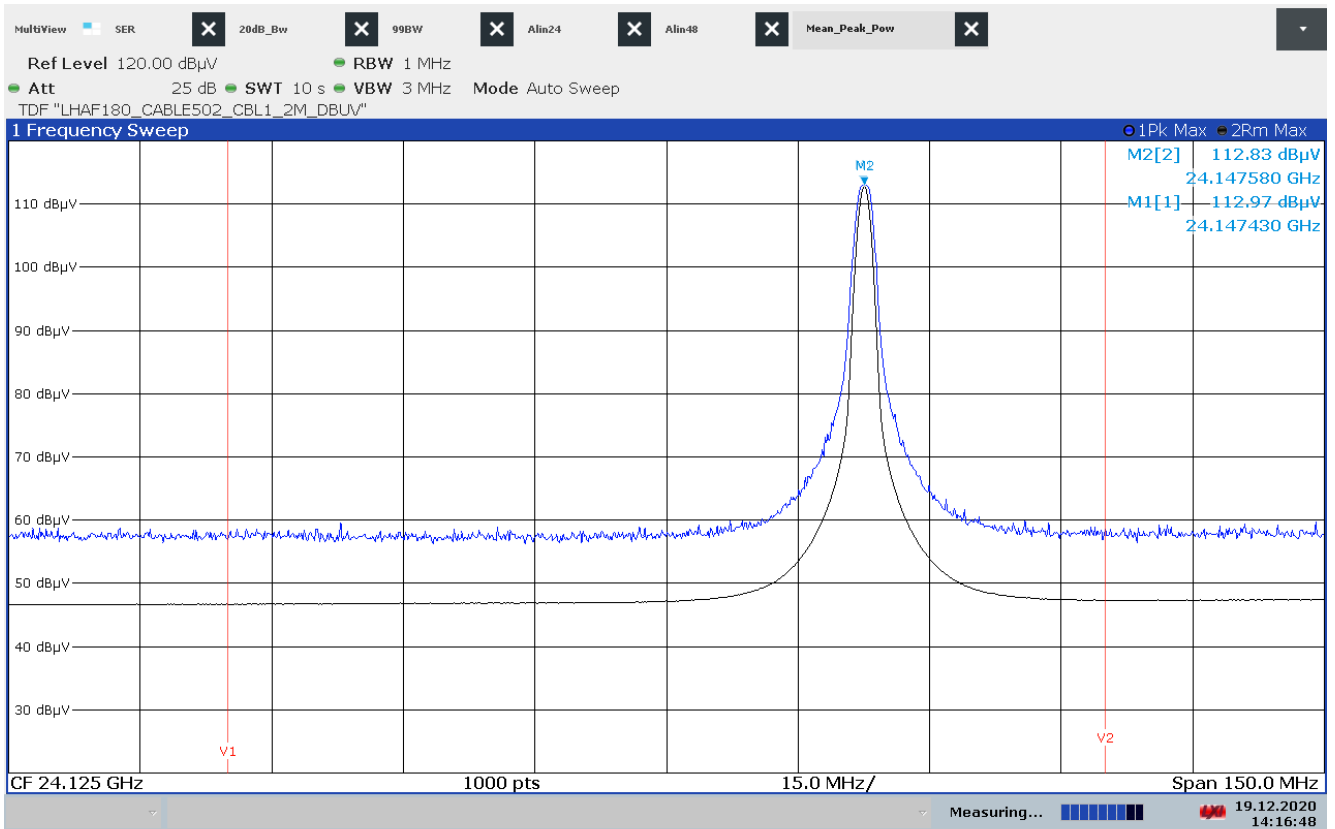

14:16:48 19.12.2020

## 11.2 Occupied bandwidth

### Description:

Measurement of the 99% bandwidth and the 20 dB bandwidth of the wanted signal.

### Measurement:

Parameter	
Detector:	Pos-Peak
Sweep time:	10 s
Resolution bandwidth:	10 kHz
Video bandwidth:	30 kHz
Span:	120 MHz
Trace-Mode:	Max Hold
Measurement uncertainty	$\pm$ Span/1000

### Limits:

FCC		IC	
CFR Part 15.245		RSS-210, F.1	
The field strength of emissions from intentional radiators operated within the specified frequency band shall comply with the following			
Frequency range	$f_L$	$f_H$	
100 MHz	> 24.075 GHz	< 24.175 GHz	

### Measurement results:

Test condition	$f_L$ (GHz)	$f_H$ (GHz)	Occupied bandwidth (kHz)
99 % BW, $T_{nom}$ , $V_{nom}$	24.14612	24.14672	598
20 dB BW, $T_{nom}$ , $V_{nom}$	24.14635	24.14685	500



Plot No. 2: 99 % BW

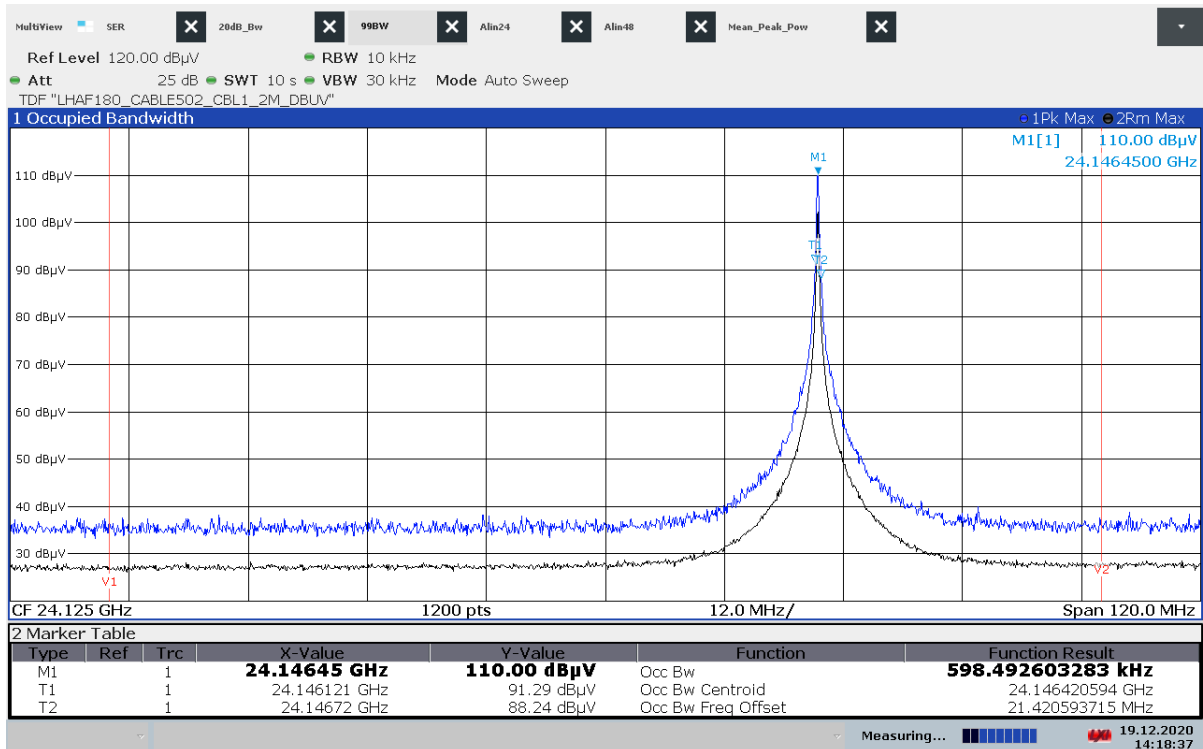

14:18:37 19.12.2020

Plot No. 3: 20 dB BW

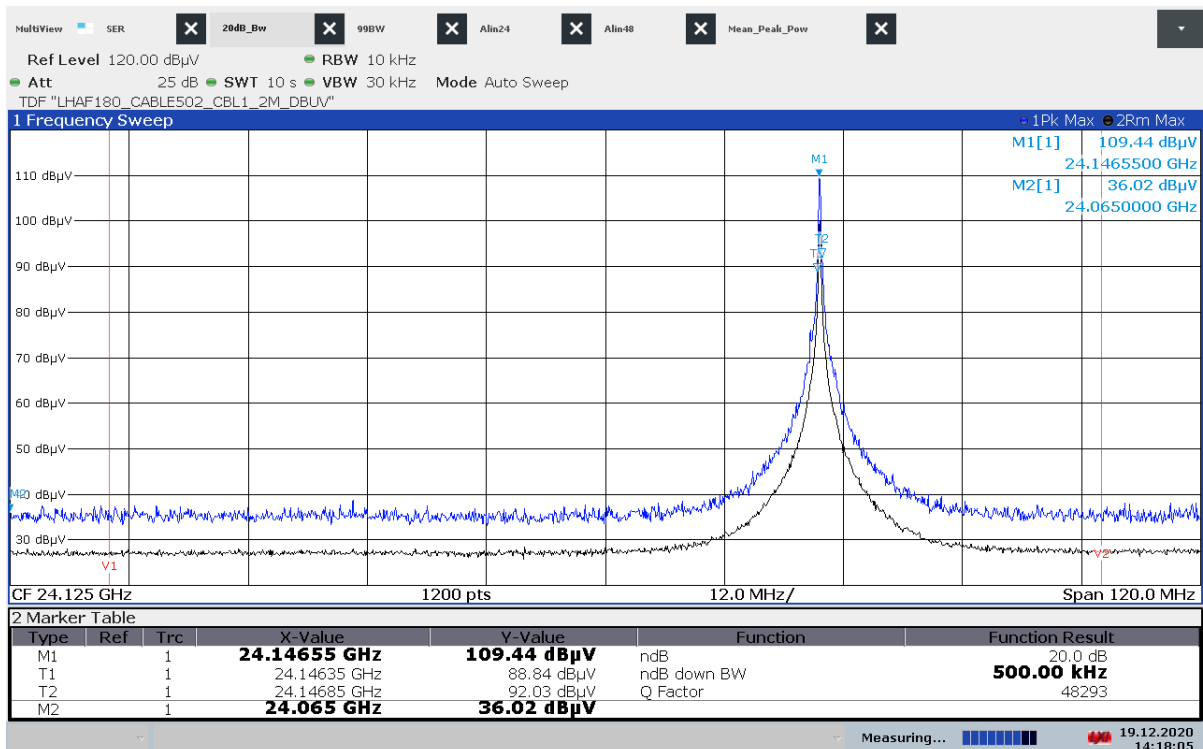

14:18:05 19.12.2020

### 11.3 Field strength of emissions (radiated spurious)

#### Description:

Measurement of the radiated spurious emissions in transmit mode.

#### Measurement:

Parameter	
Detector:	Quasi-Peak / Pos-Peak / Average
Sweep time:	Auto
Resolution bandwidth:	100 kHz / 1 MHz
Video bandwidth:	300 kHz / 3 MHz
Trace-Mode:	Max Hold
Measurement uncertainty	± 3 dB

#### Limits:

FCC		IC
CFR Part 15.209(a) / CFR Part 15.245(b)		RSS-210, F.1 / RSS - GEN
Emissions radiated outside of the specified frequency bands, except for harmonics, shall be attenuated by at least 50 dB below the level of the fundamental or to the general radiated emission limits in § 15.209, whichever is the lesser attenuation.		
Frequency (MHz)	Field Strength (µV/m)	Measurement distance (m)
0.009 – 0.490	2400/F(kHz)	300
0.490 – 1.705	24000/F(kHz)	30
1.705 – 30.0	30	30
30 – 88	100	3
88 – 216	150	3
216 – 960	200	3
Above 960	500	3

§15.245 (b) (1) Regardless of the limits shown in the table of §15.245 (b), harmonic emissions in the restricted bands below 17.7 GHz, as specified in §15.205, shall not exceed the field strength limits shown in §15.209. Harmonic emissions in the restricted bands at and above 17.7 GHz shall not exceed the following field strength limits:

(i) For the second and third harmonics of field disturbance sensors operating in the 24075-24175 MHz band and for other field disturbance sensors designed for use only within a building or to open building doors, 25.0 mV/m.

§15.245 (b)(4) The emission limits shown in §15.245 (b) are based on measurement instrumentation employing an average detector. The provisions in §15.35 for limiting peak emissions apply.

§15.31 (c) Except as otherwise indicated in §15.256, for swept frequency equipment, measurements shall be made with the frequency sweep stopped at those frequencies chosen for the measurements to be reported.

**Measurement results:**

f [GHz]	Detector	Measured level [dB $\mu$ V/m]	Margin [dB]
1.390	Peak	37.72	36.28
	RMS	24.91	29.09
1.8406	Peak	39.72	34.28
	RMS	28.86	25.14
2.458	Peak	40.90	33.10
	RMS	27.11	26.89
3.409	Peak	44.48	29.52
	RMS	32.83	21.17
6.1894	Peak	48.60	25.40
	RMS	36.99	17.01
11.8257	Peak	48.97	25.03
	RMS	37.42	16.58
48.2745*	Peak	70.08	37.92
	RMS	68.28	19.72

\*) Second harmonic for which a field strength limit of 25.0 mV/m (88 dB $\mu$ V/m) applies (based on measurement instrumentation employing an average detector). The provisions in §15.35 for limiting peak emissions apply.

**Note:**

Measurements above 50 GHz were performed on a short measurement distance ( $\leq 1$ m) to improve the minimum sensitivity of the test system. A correction factor of  $20 \cdot \log(d/3m)$  is already considered in the plots.

Plot No. 4: 9 kHz to 30 MHz

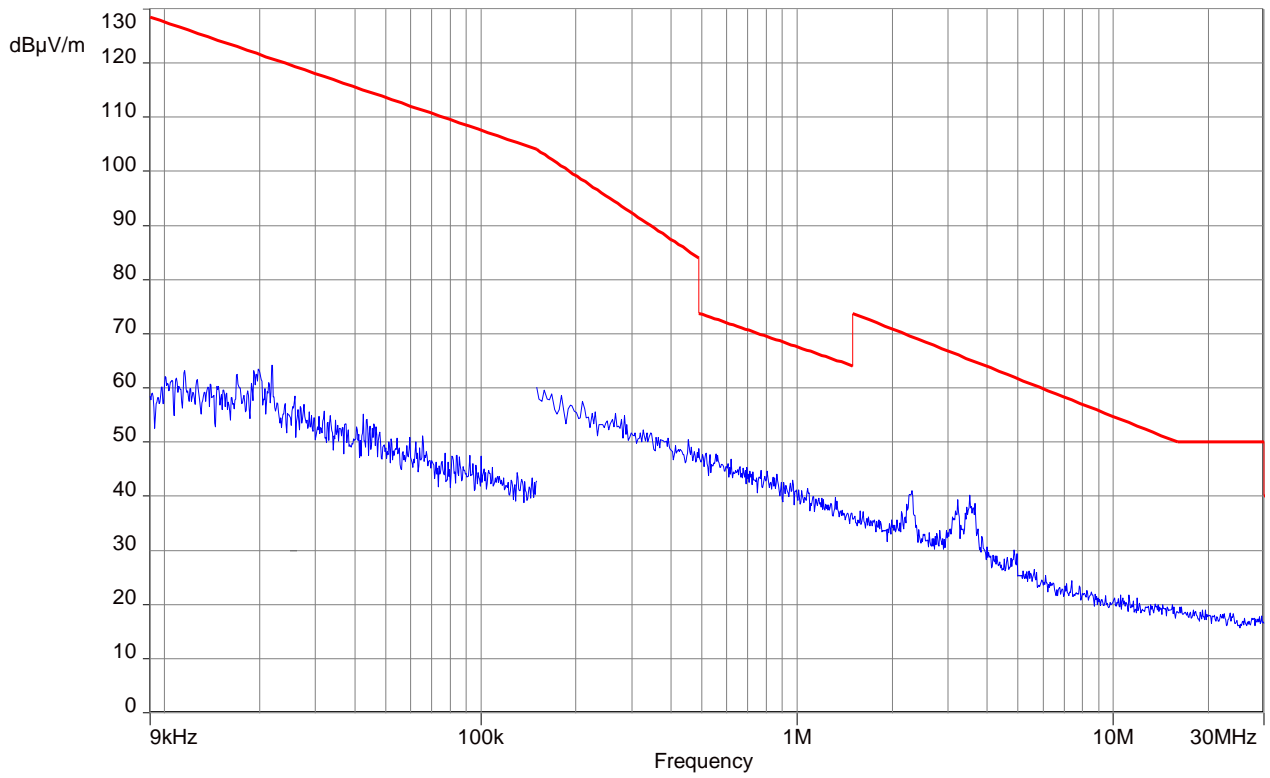

Plot No. 5: 30 MHz to 1 GHz, horizontal/vertical polarization

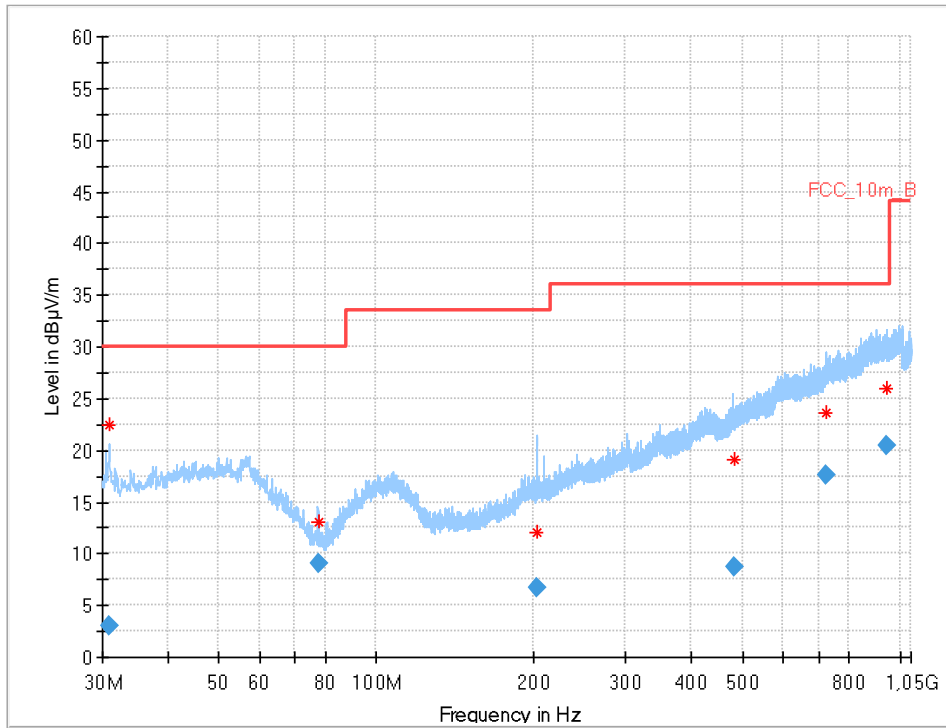

**Final Result**

Frequency (MHz)	QuasiPeak (dBµV/m)	Limit (dBµV/m)	Margin (dB)	Meas. Time (ms)	Bandwidth (kHz)	Height (cm)	Pol	Azimuth (deg)	Corr. (dB/m)
30.893	3.07	30.0	26.9	1000	120.0	193.0	V	227	12
77.413	9.04	30.0	21.0	1000	120.0	354.0	V	184	7
202.427	6.69	33.5	26.8	1000	120.0	400.0	H	135	11
481.415	8.66	36.0	27.3	1000	120.0	200.0	H	48	18
720.962	17.62	36.0	18.4	1000	120.0	250.0	V	135	21
942.418	20.44	36.0	15.6	1000	120.0	400.0	V	0	24

Plot No. 6: 1 GHz to 18 GHz

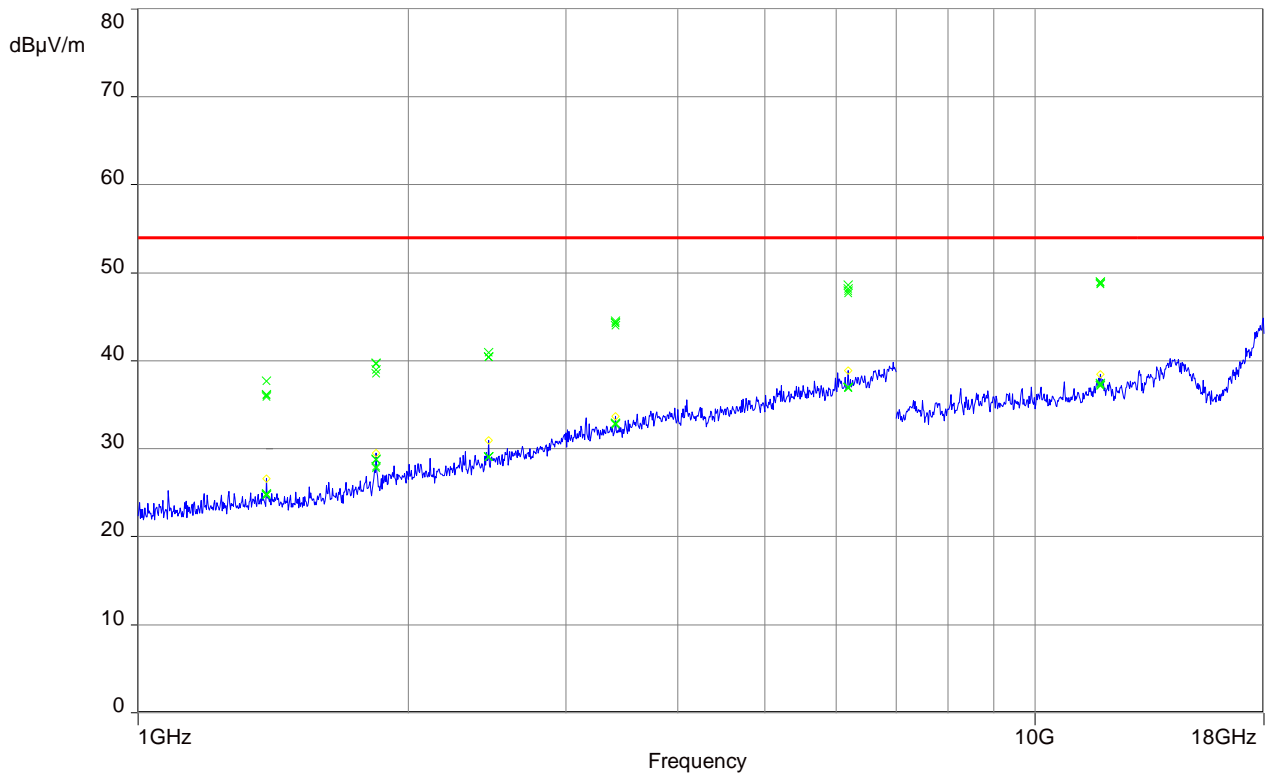

Plot No. 7: 18 GHz to 24.075 GHz

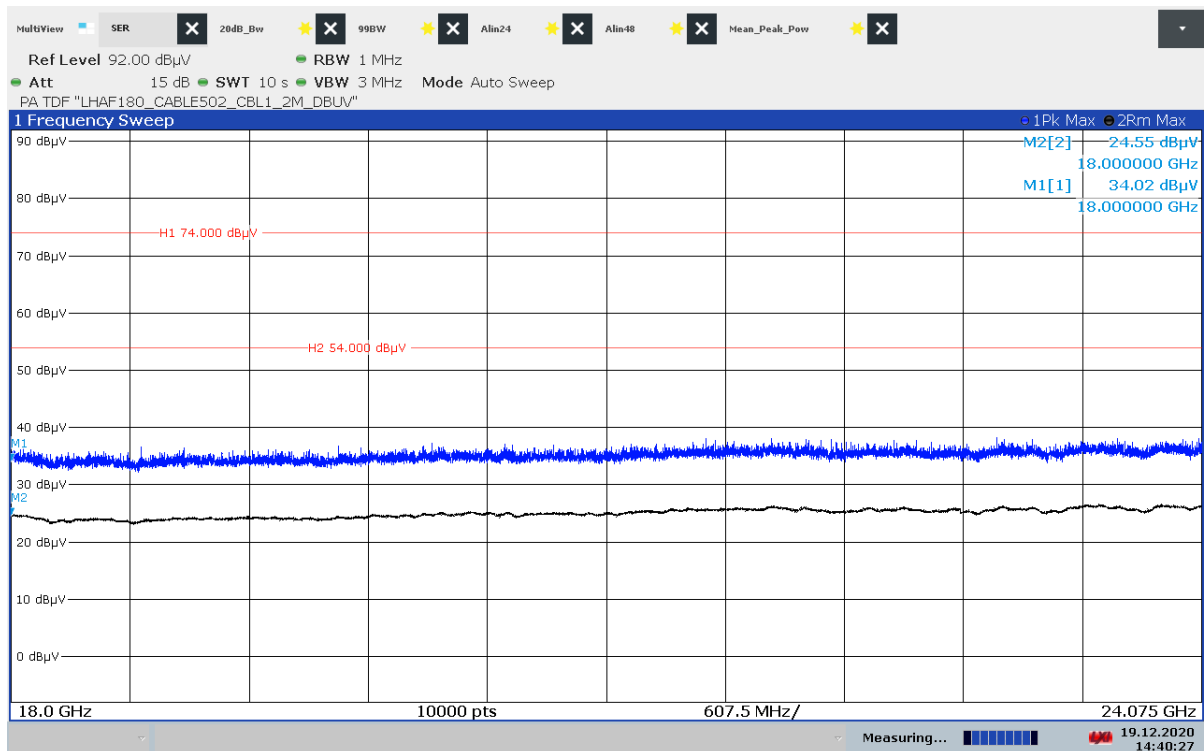

14:40:27 19.12.2020

Plot No. 8: 24.175 GHz to 40 GHz

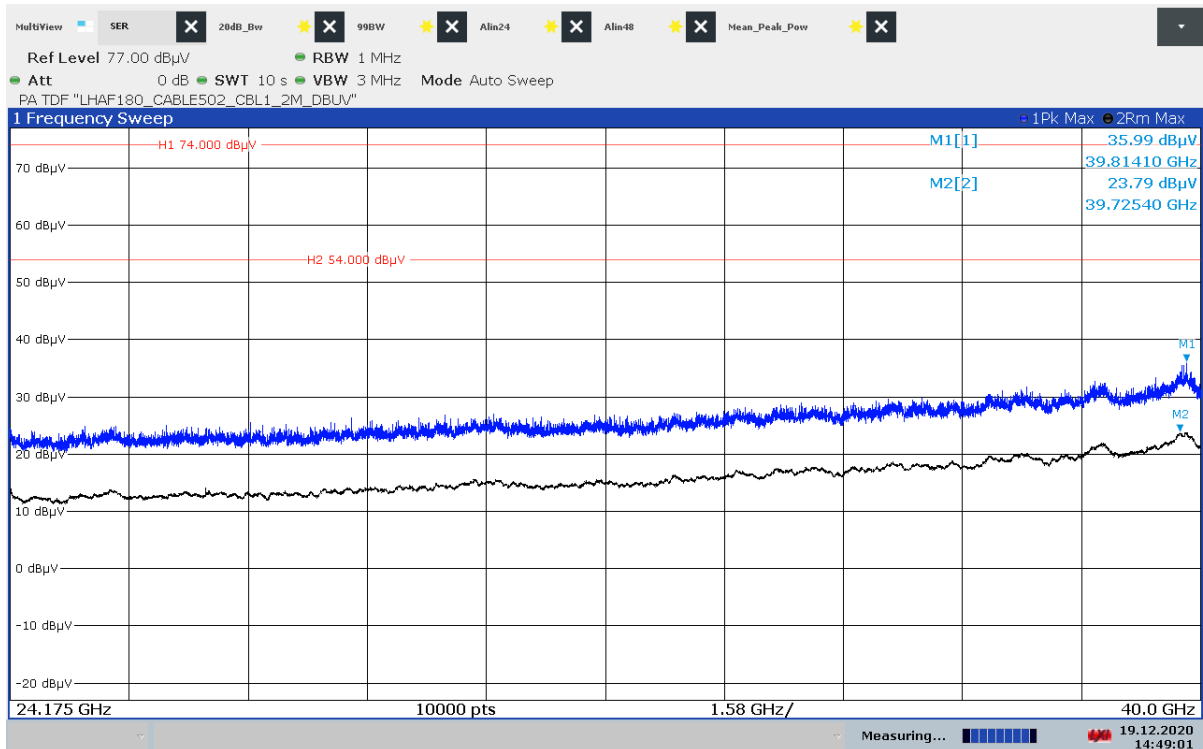

Plot No. 9: 40 GHz to 50 GHz, horizontal/vertical polarization

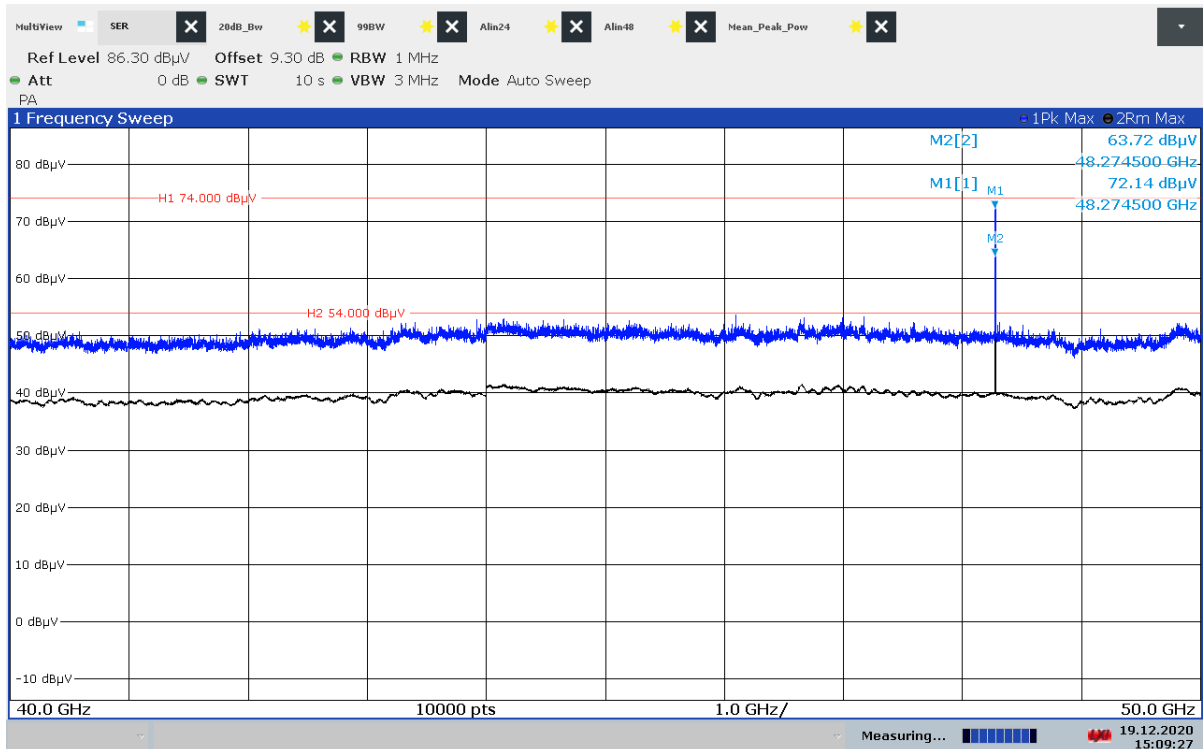

\*) Second harmonic for which a field strength limit of 25.0 mV/m (88 dBµV/m) applies (based on measurement instrumentation employing an average detector). The provisions in §15.35 for limiting peak emissions apply.

Plot No. 10: Detailed measurement of the second harmonic

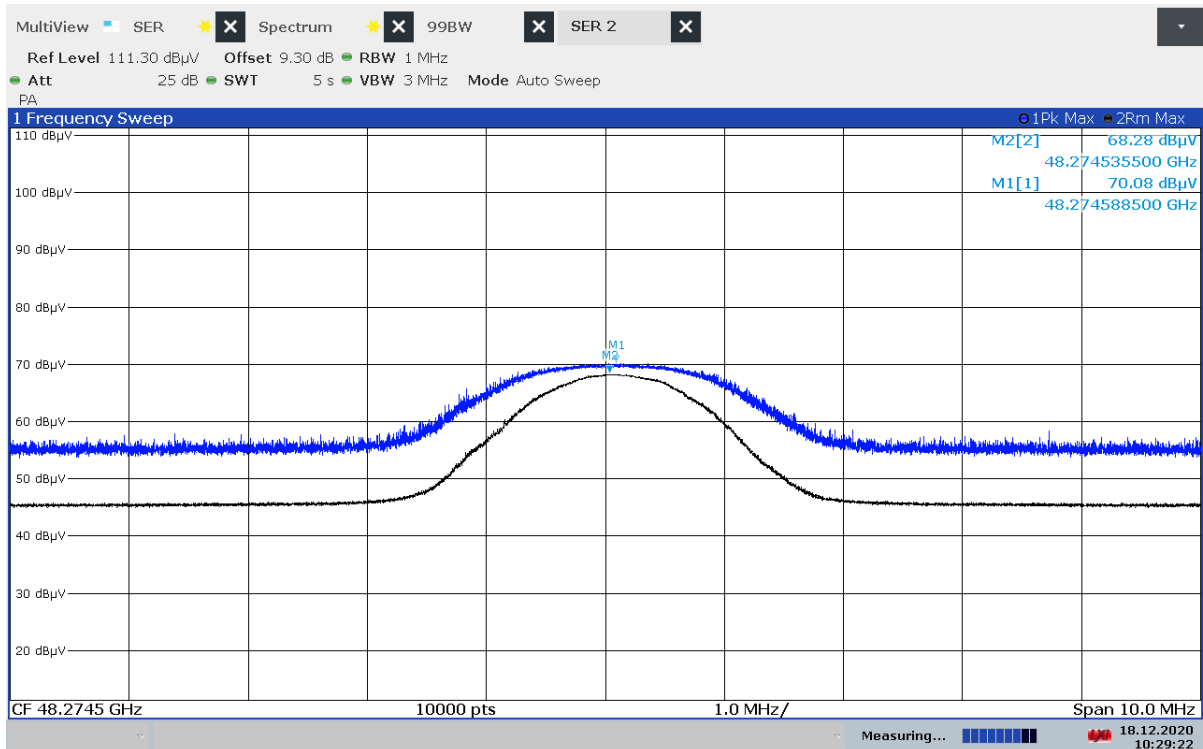

10:29:22 18.12.2020

Plot No. 11: 50 GHz to 75 GHz

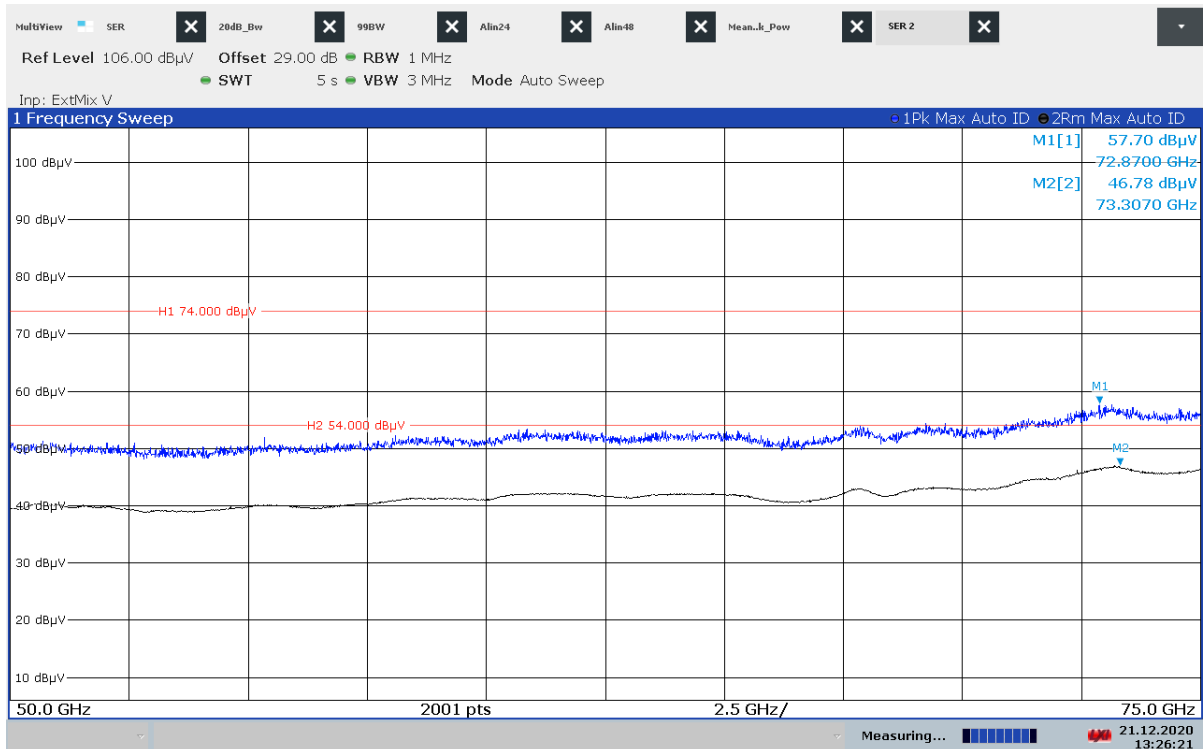

13:26:22 21.12.2020



Plot No. 12: 75 GHz to 110 GHz

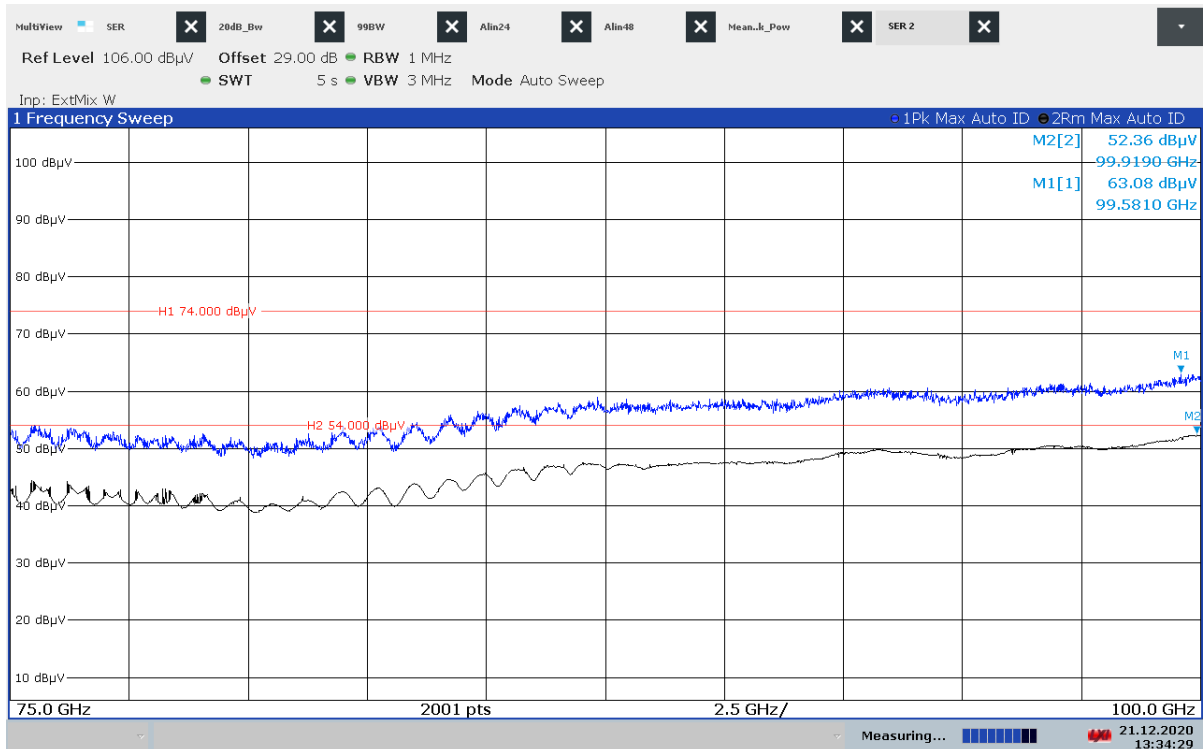

Plot No. 13: 75 GHz to 110 GHz, RBW = 100 kHz, informative measurement

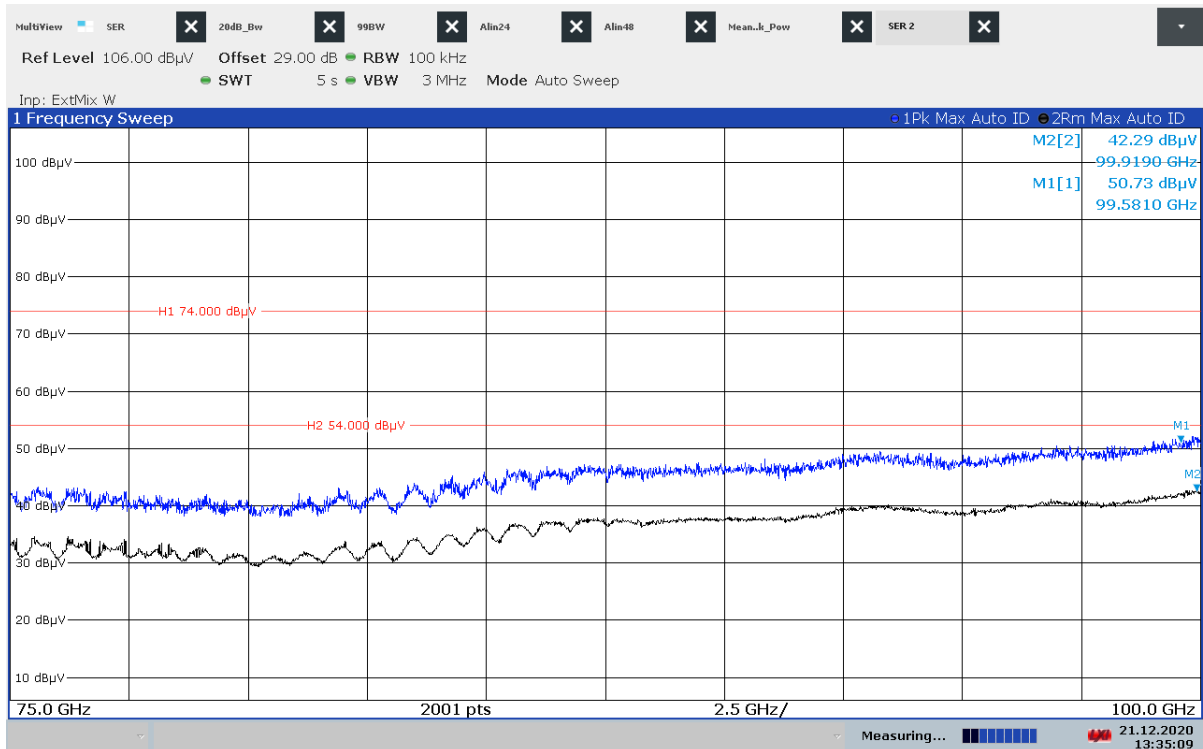

Plot No. 14: Band-edge-compliance, lower band edge

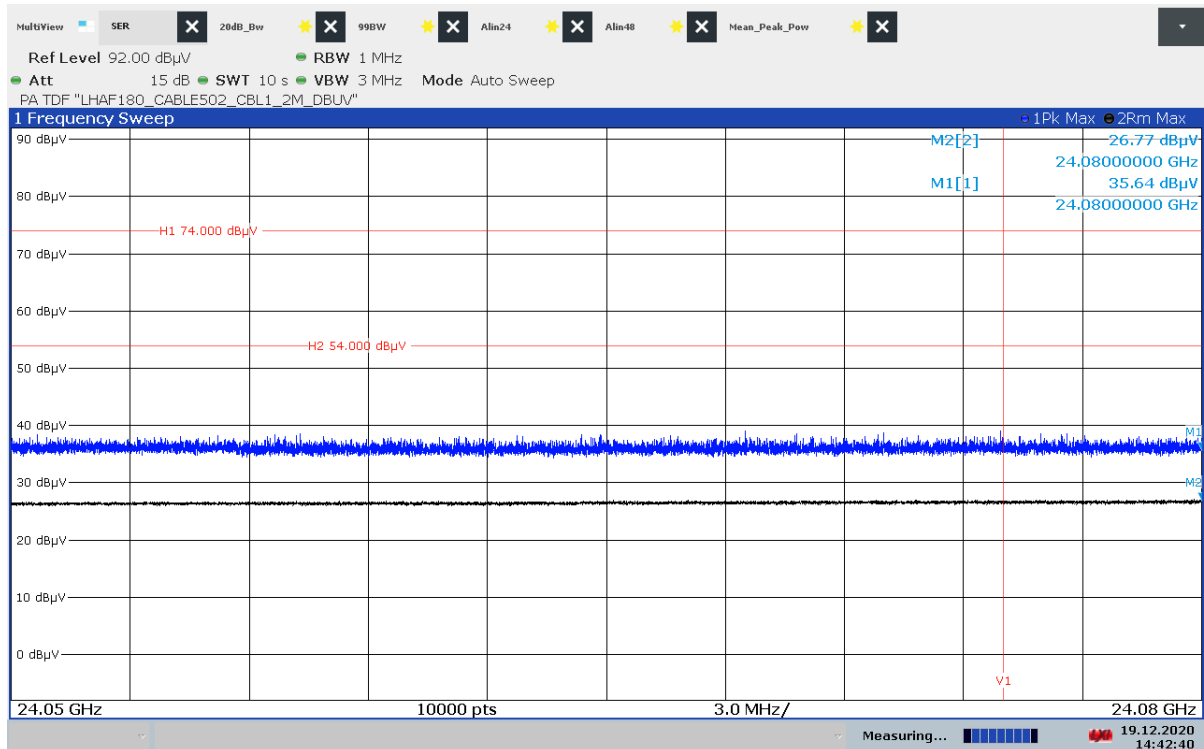

14:42:40 19.12.2020

Plot No. 15: Band-edge-compliance, higher band edge

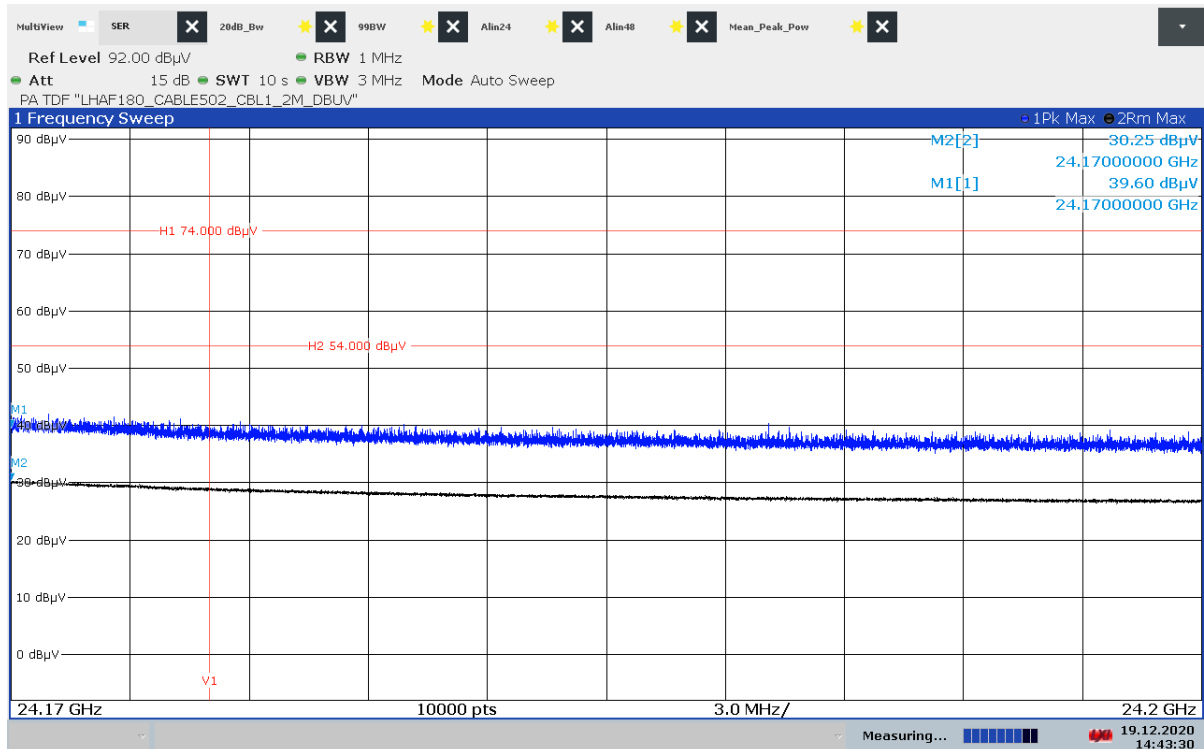

14:43:30 19.12.2020

## 11.4 Frequency Stability

### Description:

§15.215(c) Intentional radiators operating under the alternative provisions to the general emission limits, as contained in §§15.217 through 15.257 and in subpart E of this part, must be designed to ensure that the 20 dB bandwidth of the emission, or whatever bandwidth may otherwise be specified in the specific rule section under which the equipment operates, is contained within the frequency band designated in the rule section under which the equipment is operated. In the case of intentional radiators operating under the provisions of subpart E, the emission bandwidth may span across multiple contiguous frequency bands identified in that subpart. The requirement to contain the designated bandwidth of the emission within the specified frequency band includes the effects from frequency sweeping, frequency hopping and other modulation techniques that may be employed as well as the frequency stability of the transmitter over expected variations in temperature and supply voltage. If a frequency stability is not specified in the regulations, it is recommended that the fundamental emission be kept within at least the central 80% of the permitted band in order to minimize the possibility of out-of-band operation.

### Measurement:

Parameter	
Detector:	Pos-Peak
Sweep time:	10 s
Resolution bandwidth:	10 kHz / 100 kHz
Video bandwidth:	30 kHz / 300 kHz
Trace-Mode:	Max Hold
Measurement uncertainty	Span/1000

### Limits:

FCC	IC
CFR Part 15.215(c)	RSS-Gen 8.11
Frequency Stability	
As specified in Section 15.215(c), the bandwidth of the fundamental emission must be contained within the frequency band over the temperature range -20 to +50 degrees Celsius with an input voltage variation of 85% to 115% of rated input voltage.	

**Measurement results:**

Test Conditions	f <sub>L</sub> (GHz)	f <sub>H</sub> (GHz)	Occupied bandwidth (kHz)
-20 °C / V <sub>nom</sub> / 99% BW	24.17420	24.17479	592
-20 °C / V <sub>nom</sub> / 20 dB BW	24.17415	24.17475	600
-10 °C / V <sub>nom</sub> / 99% BW	24.17103	24.17161	574
-10 °C / V <sub>nom</sub> / 20 dB BW	24.17125	24.17185	600
0 °C / V <sub>nom</sub> / 99% BW	24.16670	24.16728	580
0 °C / V <sub>nom</sub> / 20 dB BW	24.16645	24.16705	600
+10 °C / V <sub>nom</sub> / 99% BW	24.15471	24.15536	652
+10 °C / V <sub>nom</sub> / 20 dB BW	24.15475	24.15525	500
+20 °C / V <sub>nom</sub> / 99% BW	24.14645	24.14672	598
+20 °C / V <sub>nom</sub> / 20 dB BW	24.14635	24.14685	500
+30 °C / V <sub>nom</sub> / 99% BW	24.13347	24.13396	494
+30 °C / V <sub>nom</sub> / 20 dB BW	24.13325	24.13365	400
+40 °C / V <sub>nom</sub> / 99% BW	24.12106	24.12159	528
+40 °C / V <sub>nom</sub> / 20 dB BW	24.12125	24.12155	300
+50 °C / V <sub>nom</sub> / 99% BW	24.11450	24.11496	469
+50 °C / V <sub>nom</sub> / 20 dB BW	24.11415	24.11465	500

Voltage Variation	f <sub>L</sub> (GHz)	f <sub>H</sub> (GHz)
V <sub>min</sub> < 85 % of U, if not declared otherwise by customer	Voltage variation does not affect the radiated signal	
V <sub>max</sub> > 115 % of U, if not declared otherwise by customer		

Plot 16: -20 °C, V<sub>nom</sub>, 99% BW

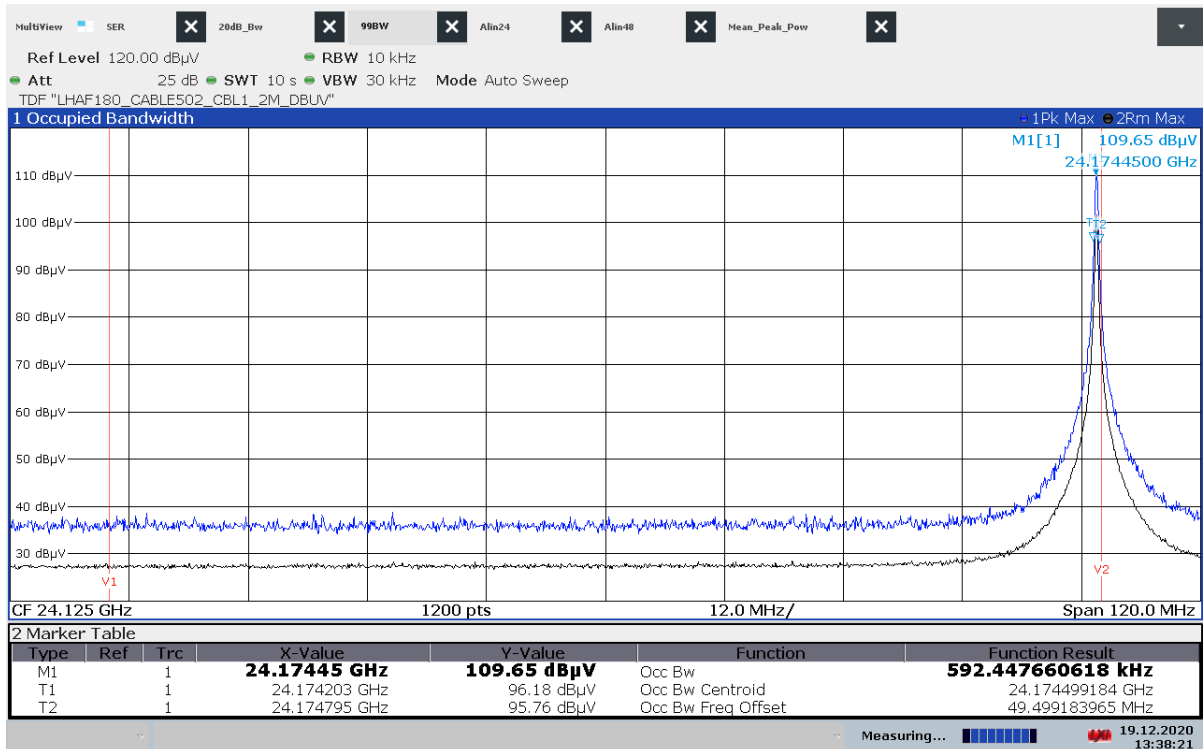

13:38:22 19.12.2020

Plot 17: -20 °C, V<sub>nom</sub>, 20 dB BW

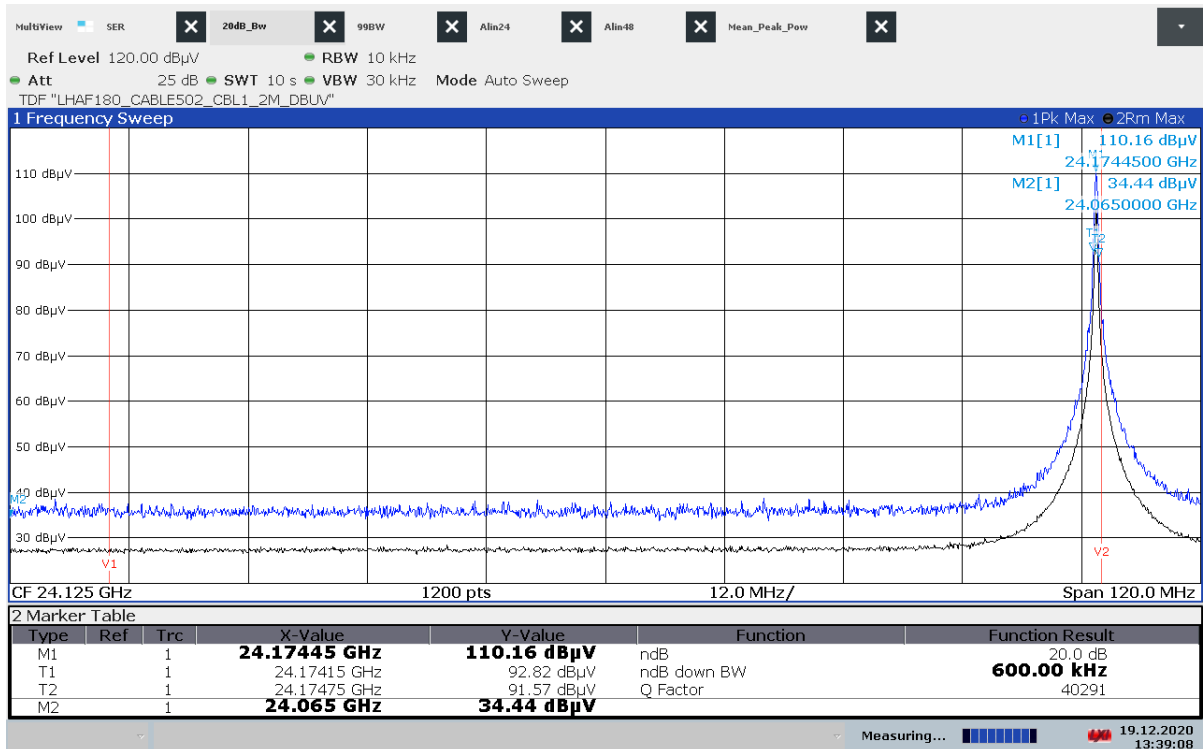

13:39:09 19.12.2020

Plot 18: -10 °C, V<sub>nom</sub>, 99% BW

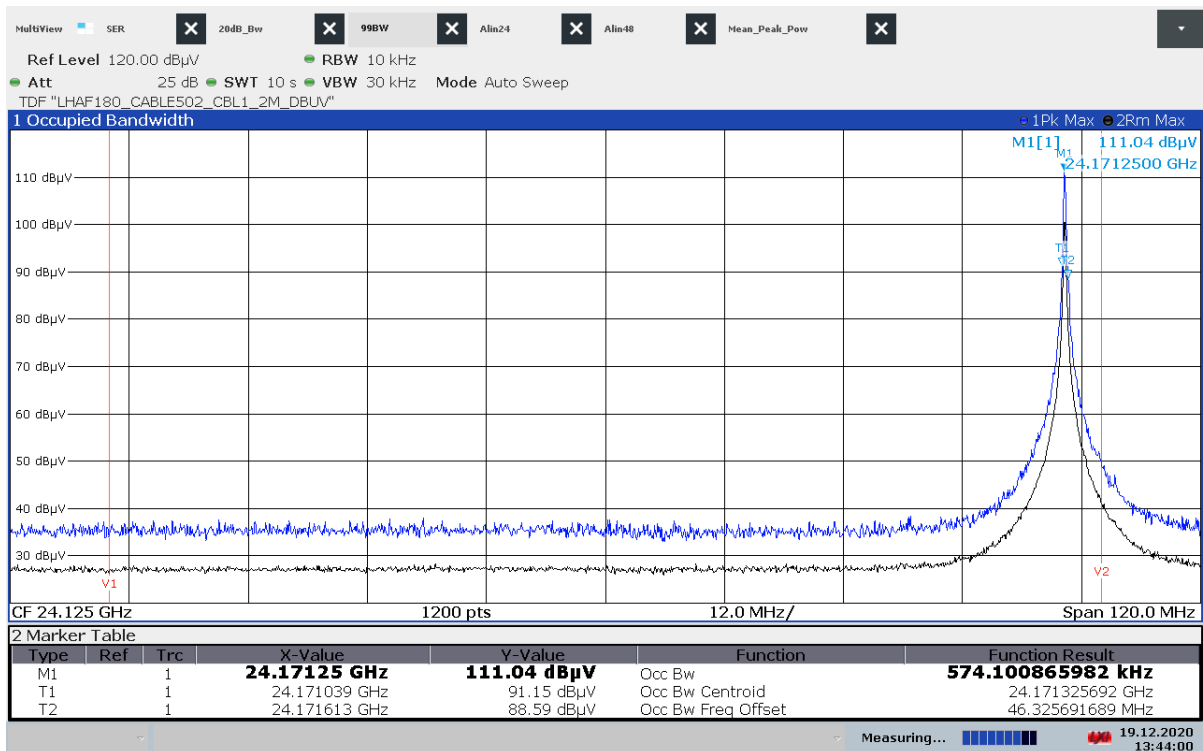

13:44:00 19.12.2020

Plot 19: -10 °C, V<sub>nom</sub>, 20 dB BW

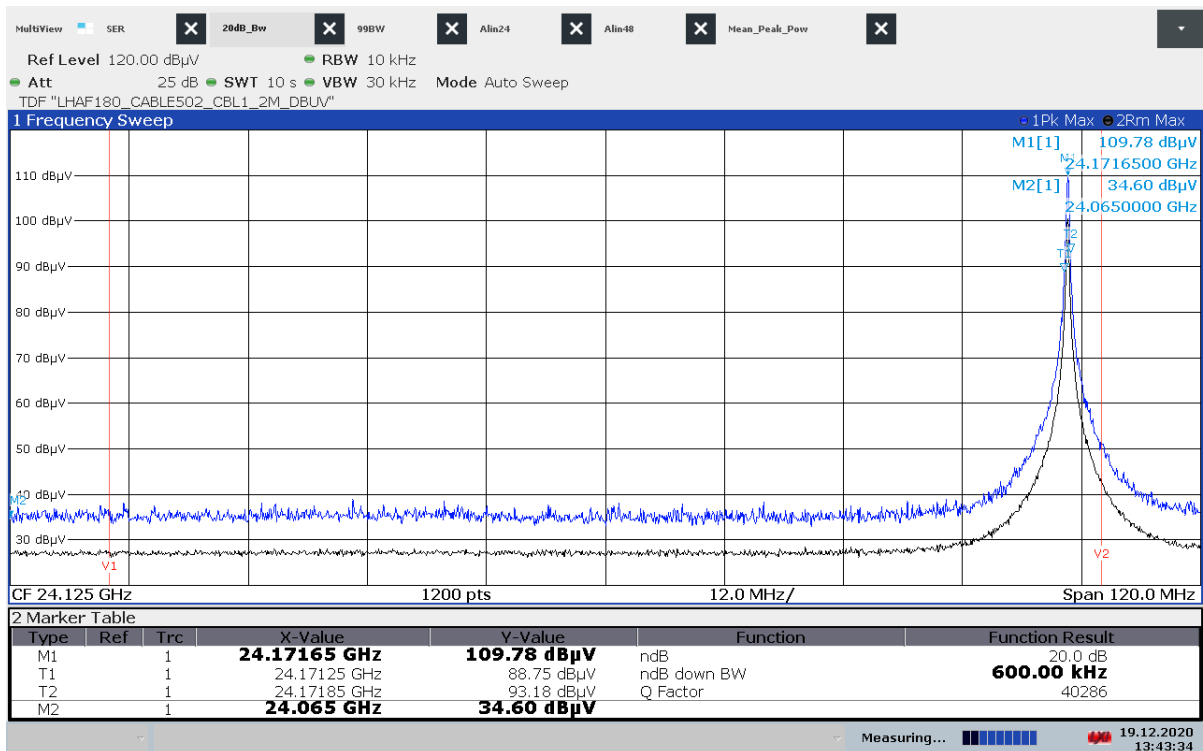

13:43:34 19.12.2020

Plot 20: 0 °C, V<sub>nom</sub>, 99% BW

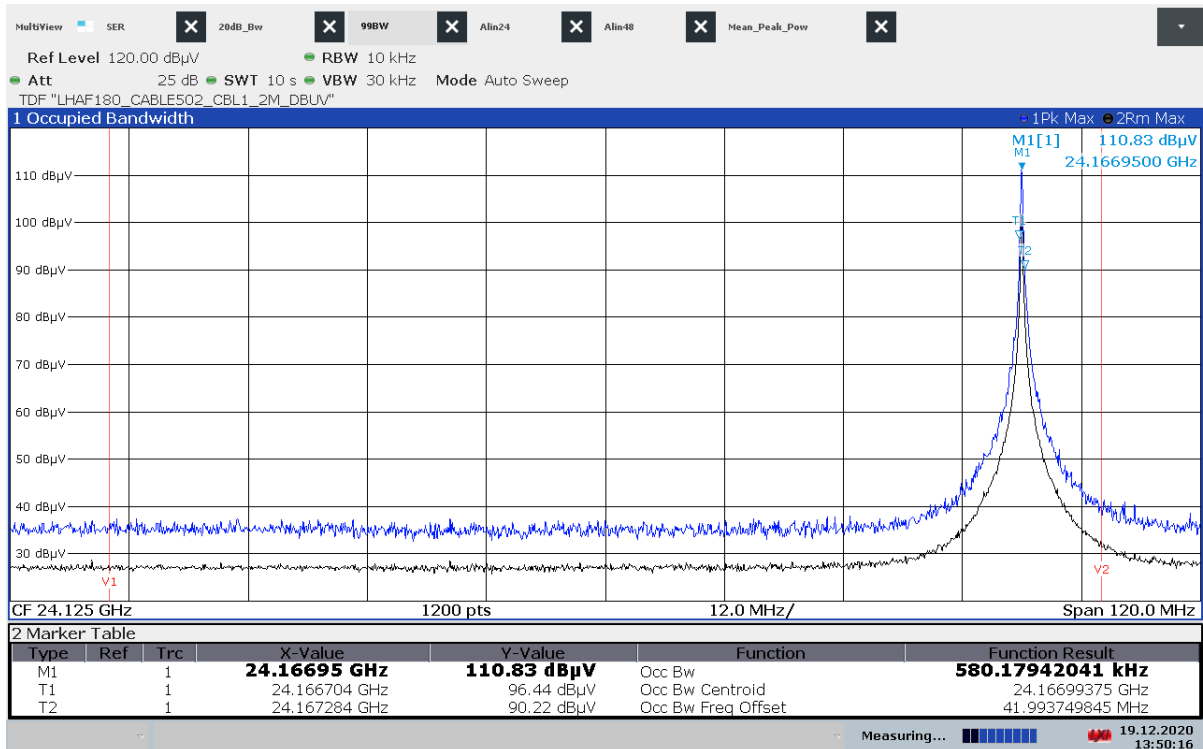

13:50:17 19.12.2020

Plot 21: 0 °C, V<sub>nom</sub>, 20 dB BW

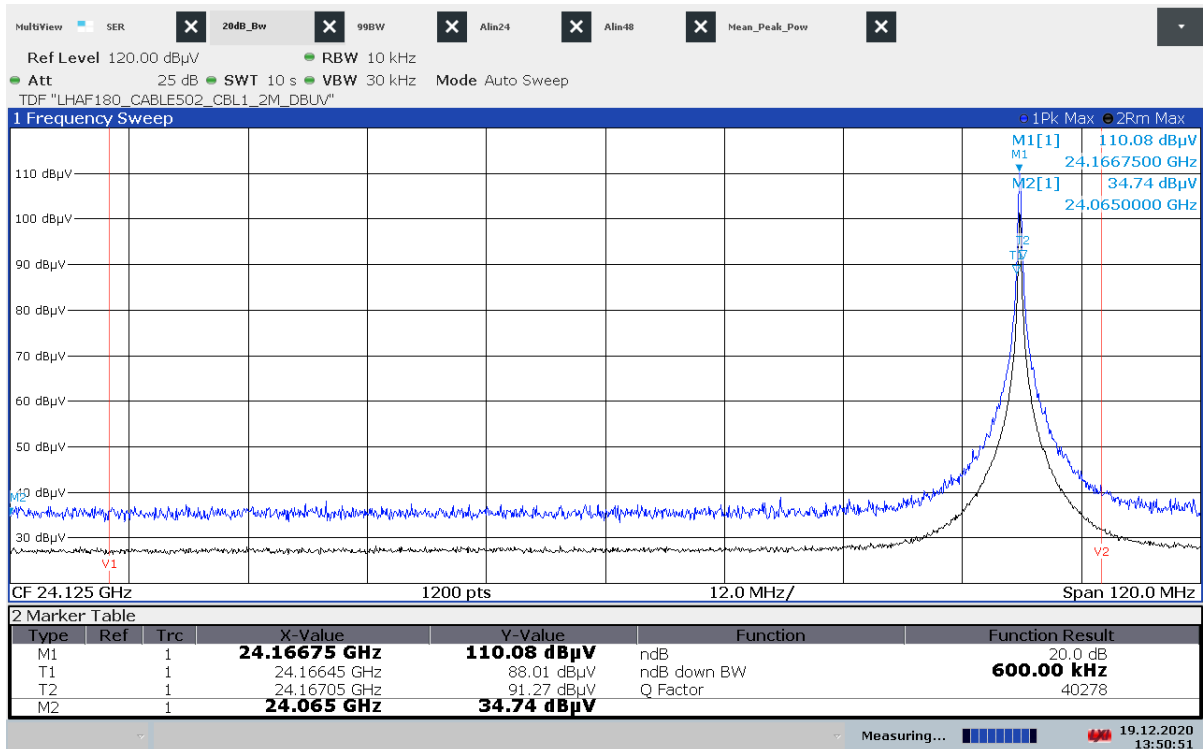

13:50:51 19.12.2020

Plot 22: +10 °C, V<sub>nom</sub>, 99% BW

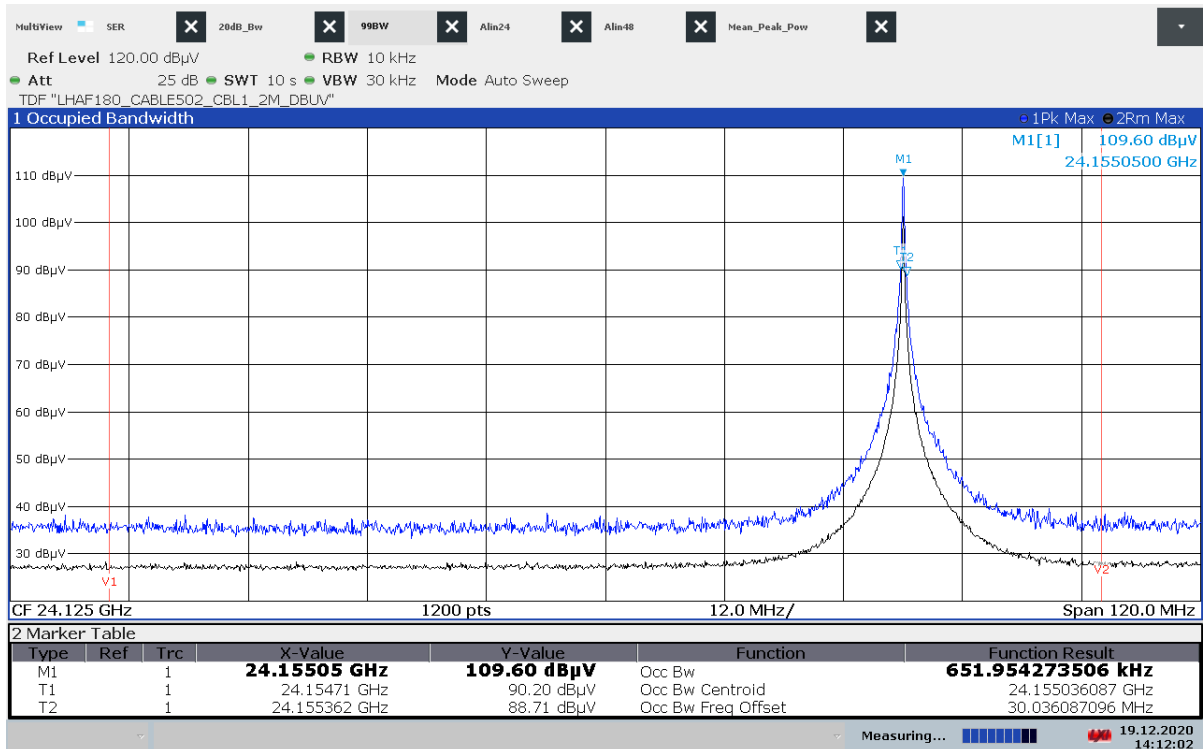

14:12:02 19.12.2020

Plot 23: +10 °C, V<sub>nom</sub>, 20 dB BW

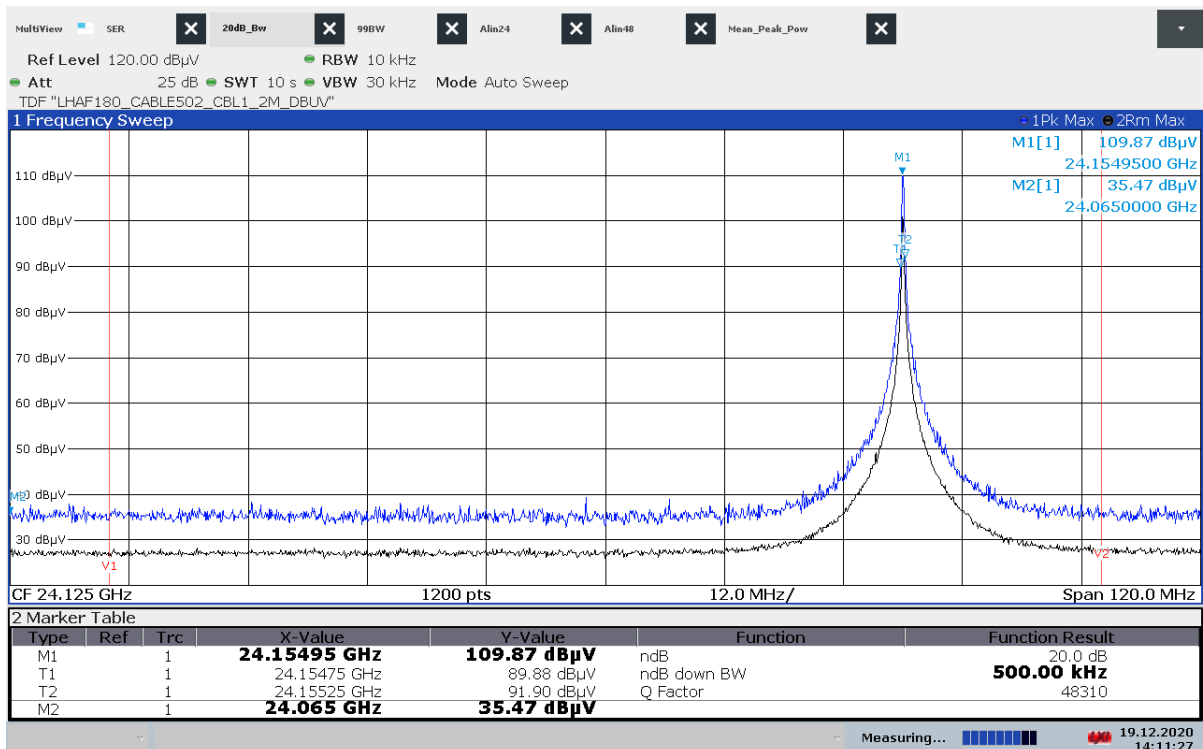

14:11:28 19.12.2020



Plot 24: +20 °C, V<sub>nom</sub>, 99% BW

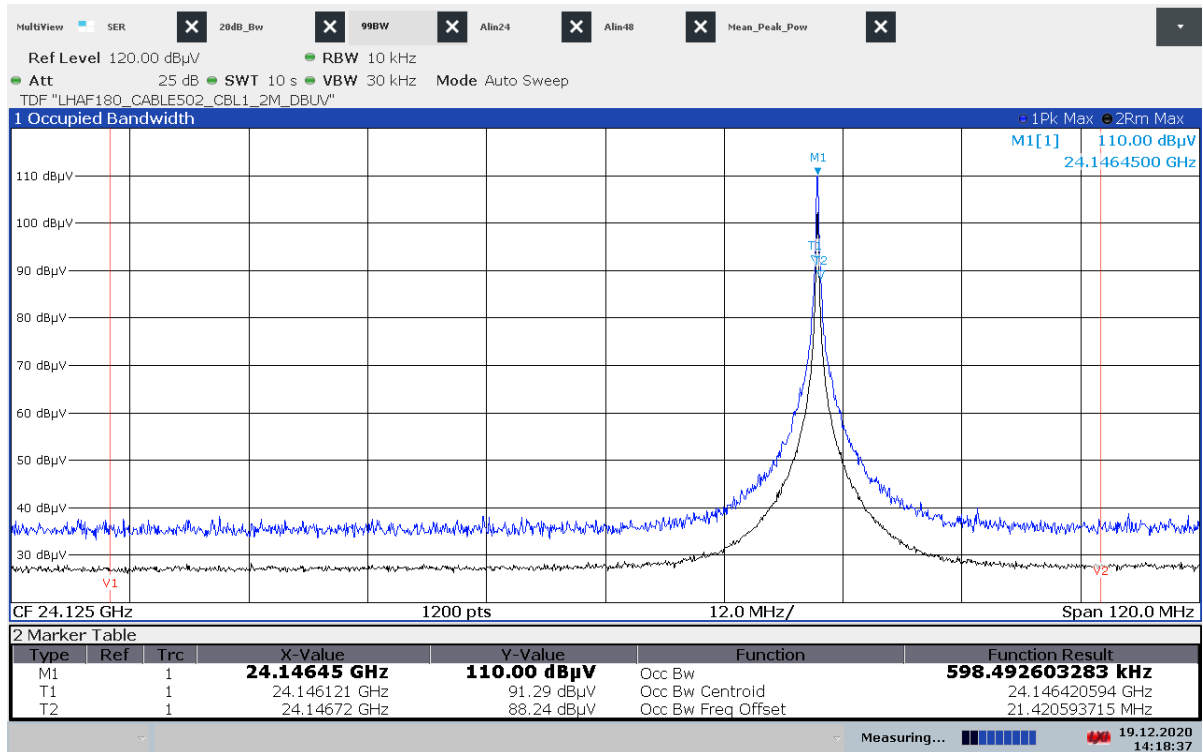

14:18:37 19.12.2020

Plot 25: +20 °C, V<sub>nom</sub>, 20 dB BW

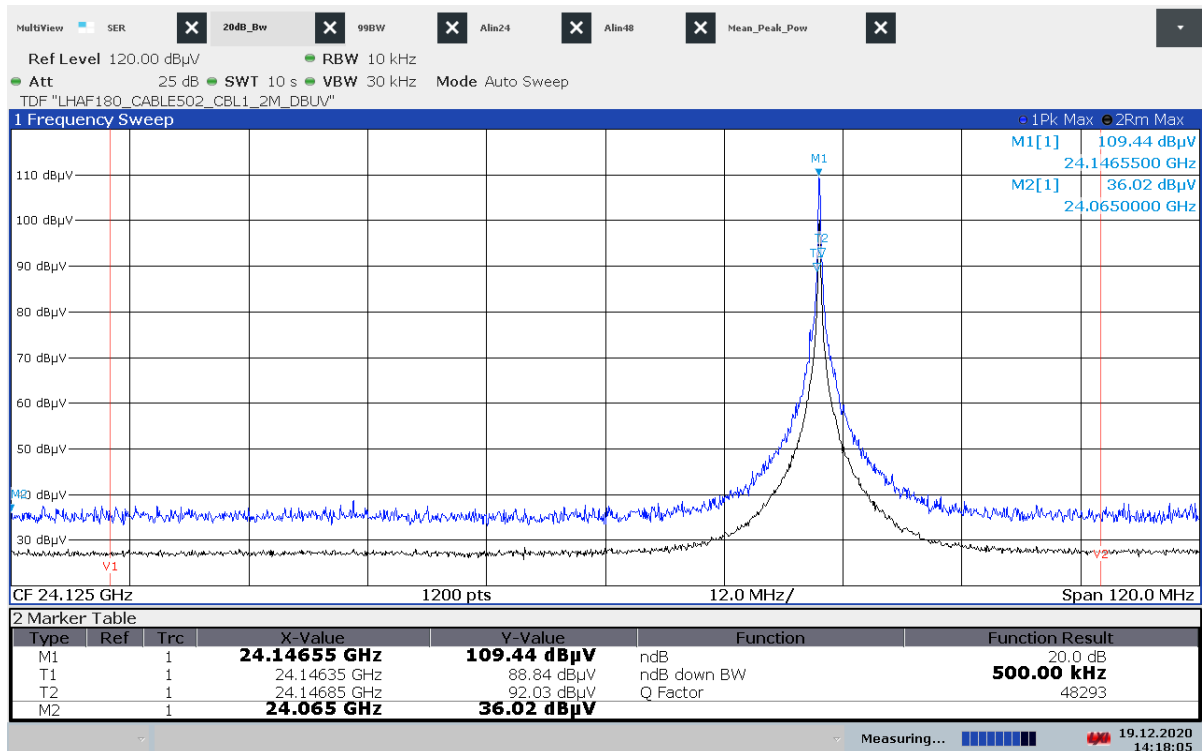

14:18:05 19.12.2020

Plot 26: +30 °C, V<sub>nom</sub>, 99% BW

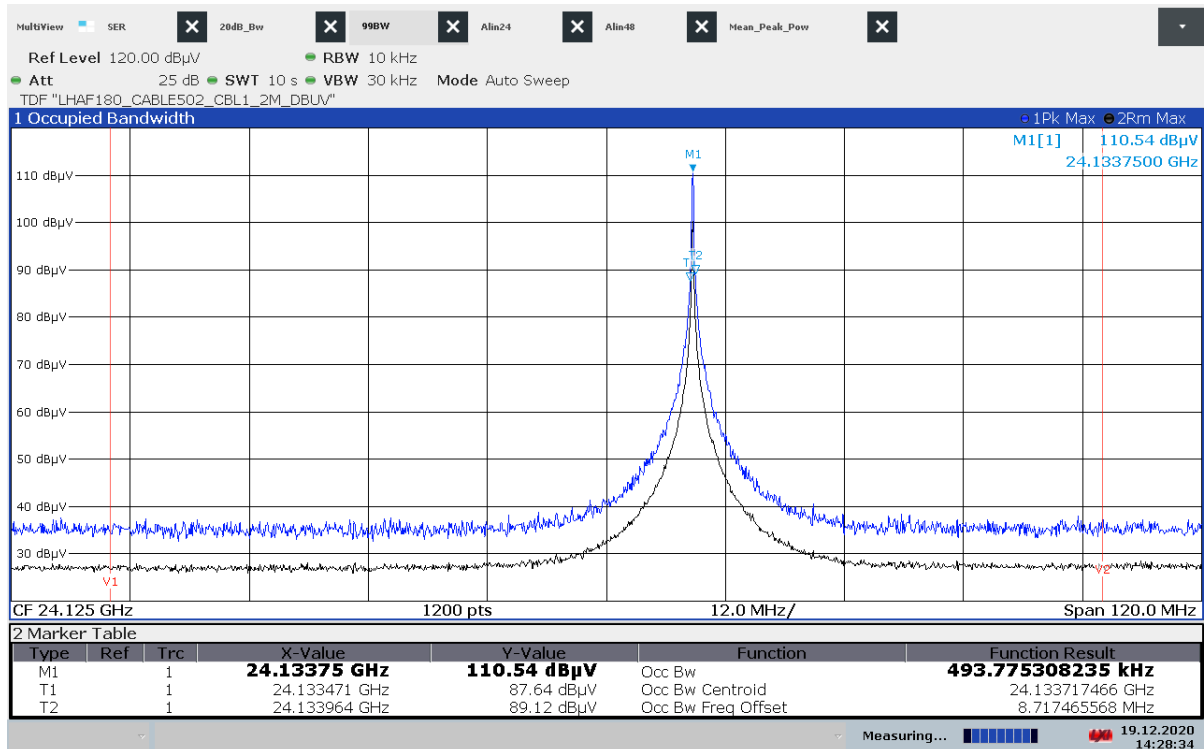

14:28:34 19.12.2020

Plot 27: +30 °C, V<sub>nom</sub>, 20 dB BW

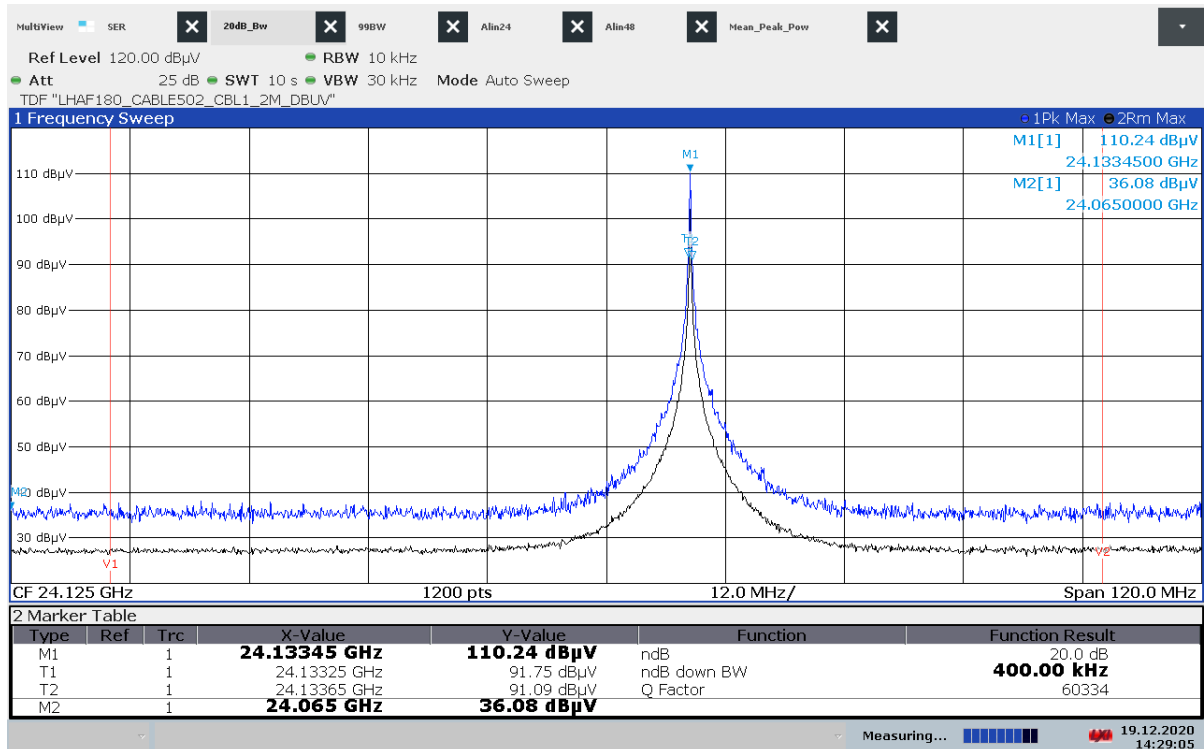

14:29:05 19.12.2020

Plot 28: +40 °C, V<sub>nom</sub>, 99% BW

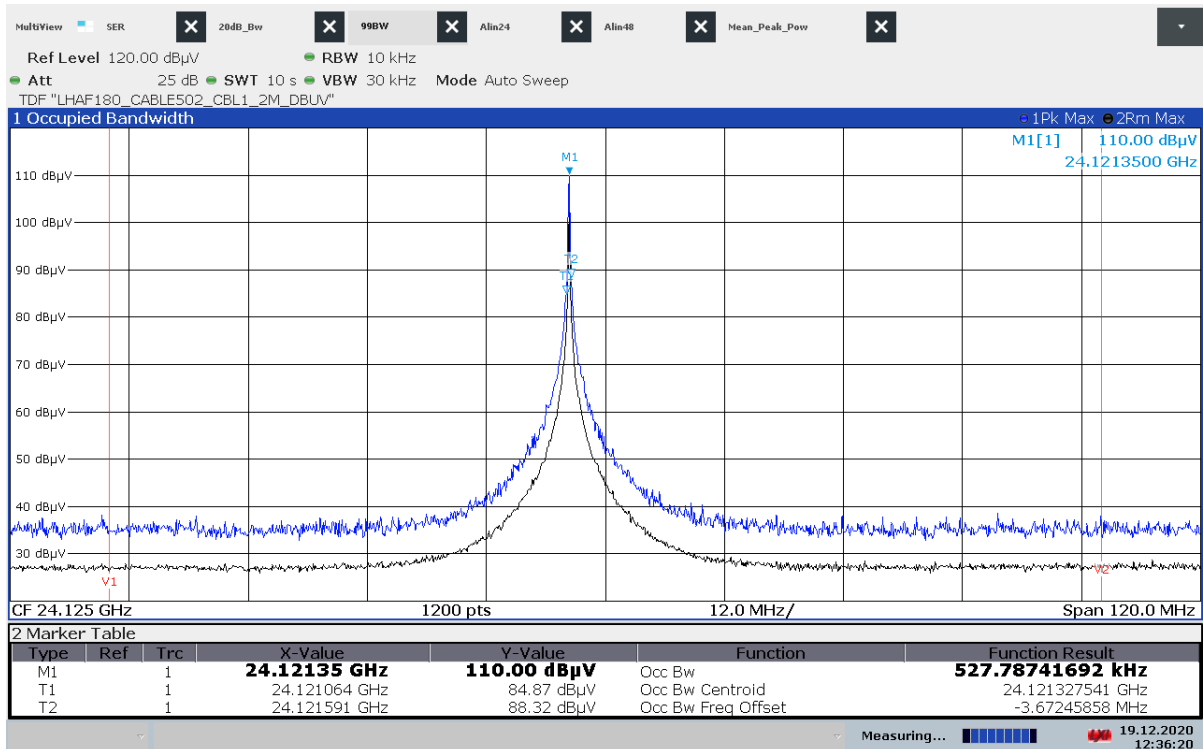

12:36:21 19.12.2020

Plot 29: +40 °C, V<sub>nom</sub>, 20 dB BW

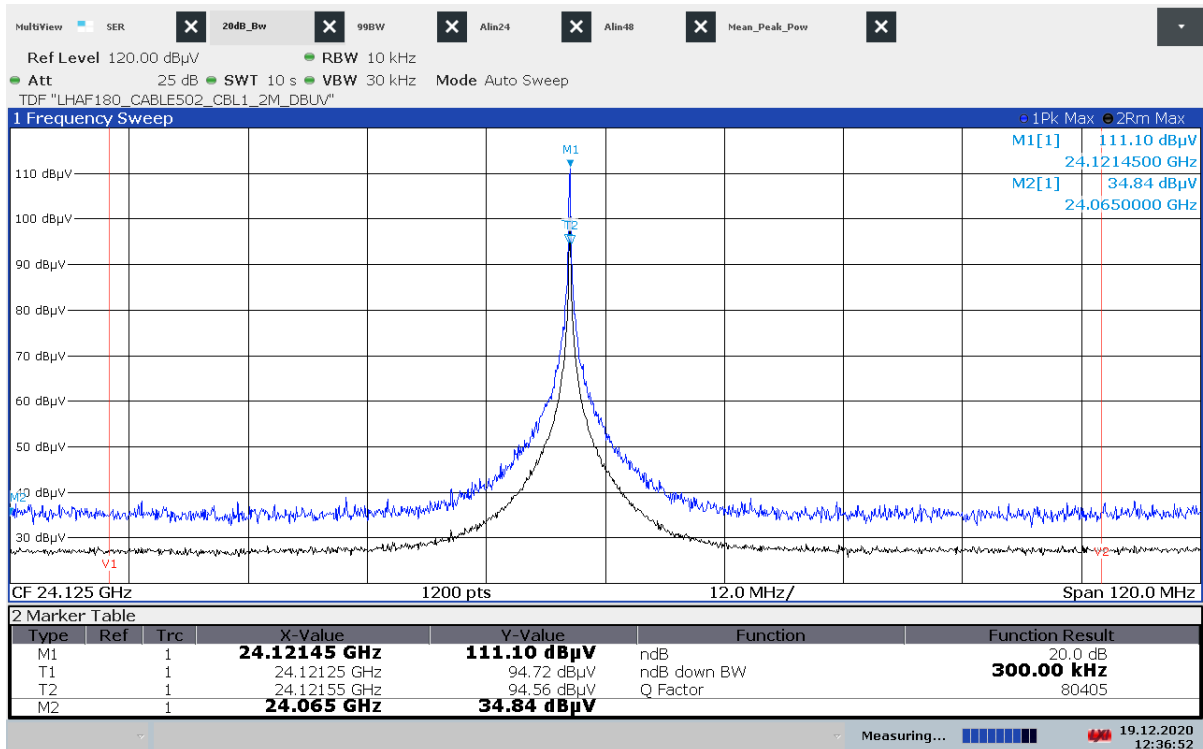

12:36:52 19.12.2020

Plot 30: +50 °C, V<sub>nom</sub>, 99% BW

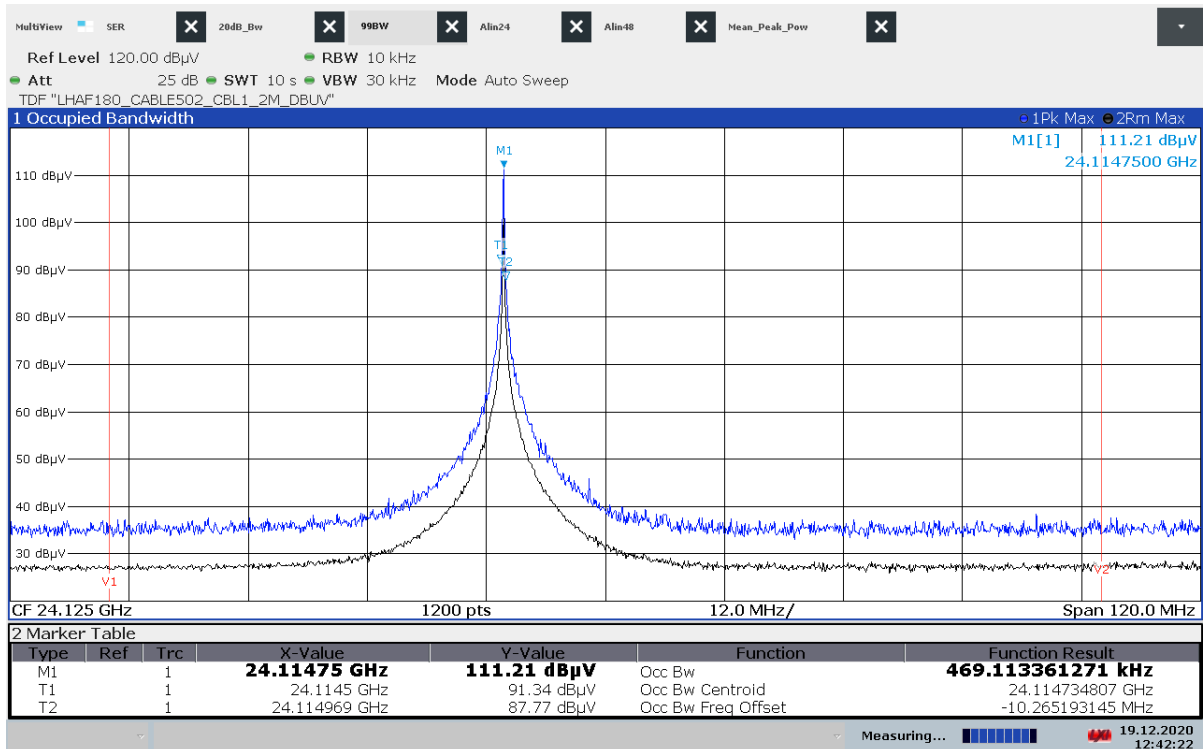

12:42:23 19.12.2020

Plot 31: +50 °C, V<sub>nom</sub>, 20 dB BW

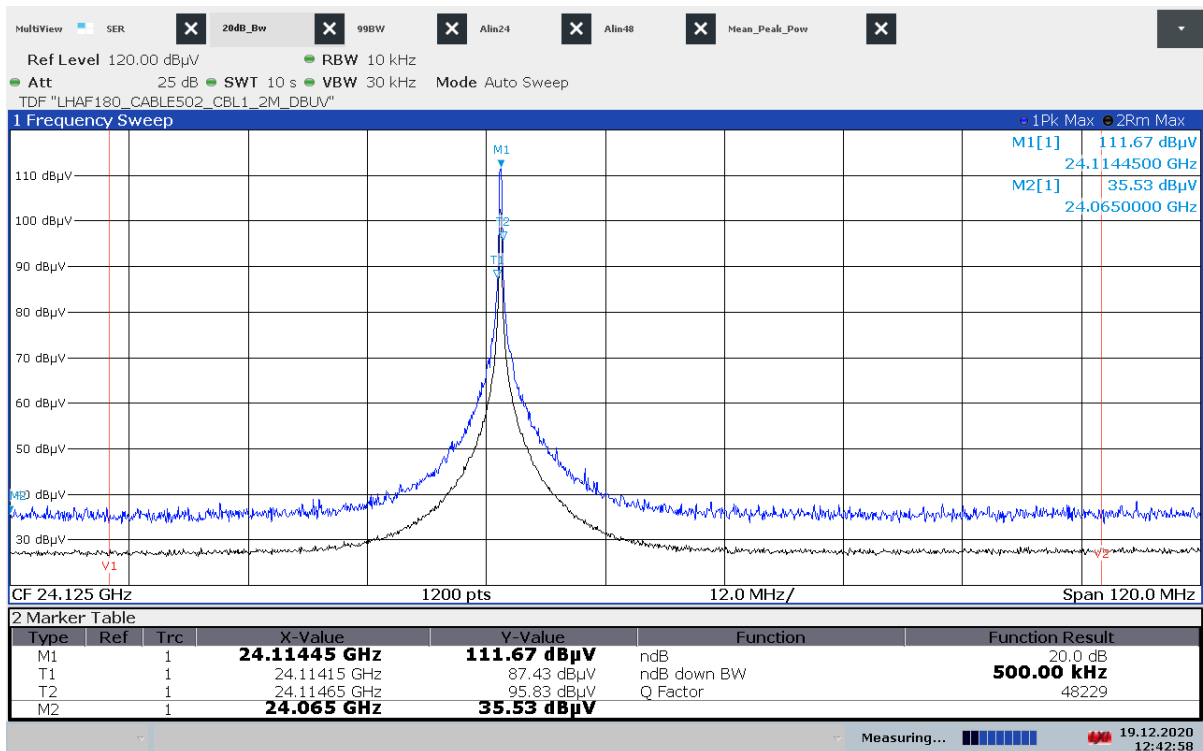

12:42:59 19.12.2020

## Annex A Glossary

<b>EUT</b>	Equipment under test
<b>DUT</b>	Device under test
<b>UUT</b>	Unit under test
<b>GUE</b>	GNSS User Equipment
<b>ETSI</b>	European Telecommunications Standards Institute
<b>EN</b>	European Standard
<b>FCC</b>	Federal Communications Commission
<b>FCC ID</b>	Company Identifier at FCC
<b>IC</b>	Industry Canada
<b>PMN</b>	Product marketing name
<b>HMN</b>	Host marketing name
<b>HVIN</b>	Hardware version identification number
<b>FVIN</b>	Firmware version identification number
<b>EMC</b>	Electromagnetic Compatibility
<b>HW</b>	Hardware
<b>SW</b>	Software
<b>Inv. No.</b>	Inventory number
<b>S/N or SN</b>	Serial number
<b>C</b>	Compliant
<b>NC</b>	Not compliant
<b>NA</b>	Not applicable
<b>NP</b>	Not performed
<b>PP</b>	Positive peak
<b>QP</b>	Quasi peak
<b>AVG</b>	Average
<b>OC</b>	Operating channel
<b>OCW</b>	Operating channel bandwidth
<b>OBW</b>	Occupied bandwidth
<b>OOB</b>	Out of band
<b>DFS</b>	Dynamic frequency selection
<b>CAC</b>	Channel availability check
<b>OP</b>	Occupancy period
<b>NOP</b>	Non occupancy period
<b>DC</b>	Duty cycle
<b>PER</b>	Packet error rate
<b>CW</b>	Clean wave
<b>MC</b>	Modulated carrier
<b>WLAN</b>	Wireless local area network
<b>RLAN</b>	Radio local area network
<b>DSSS</b>	Dynamic sequence spread spectrum
<b>OFDM</b>	Orthogonal frequency division multiplexing
<b>FHSS</b>	Frequency hopping spread spectrum
<b>GNSS</b>	Global Navigation Satellite System
<b>C/N<sub>0</sub></b>	Carrier to noise-density ratio, expressed in dB-Hz

**Annex B Document history**

Version	Applied changes	Date of release
-/-	Initial release	2021-06-30

**Annex C Accreditation Certificate**

first page	last page
 <p>The first page of the accreditation certificate includes the DAKKS logo, the name of the accreditation body (Deutsche Akkreditierungsstelle GmbH), and the accreditation details for CTC advanced GmbH. It states that the company is competent under the terms of DIN EN ISO/IEC 17025:2018 to carry out tests in the field of Telecommunication (FCC Requirements). The certificate is signed by the Head of Division on 09.06.2020.</p>	 <p>The last page of the accreditation certificate provides contact information for three offices: Berlin, Frankfurt am Main, and Braunschweig. It also includes a disclaimer regarding the publication of extracts and the scope of accreditation.</p>

**Note: The current certificate annex is published on the website (link see below) of the Accreditation Body DAKKS or may be received by CTC advanced GmbH on request**

<https://www.dakks.de/as/ast/d/D-PL-12076-01-05e.pdf>

##### END OF TEST REPORT #####