

FCC Test Report

Report No.: RF160314E01

FCC ID: G95TCA300

Test Model: TCA300COM

Received Date: Mar. 14, 2016

Test Date: Apr. 27 to 29, 2016

Issued Date: May 23, 2016

Applicant: Technicolor Connected Home USA LLC

Address: 101 West 103rd Street, Indianapolis, IN 46290 United States

Issued By: Bureau Veritas Consumer Products Services (H.K.) Ltd., Taoyuan Branch
Hsin Chu Laboratory

Lab Address: E-2, No.1, Li Hsin 1st Road, Hsinchu Science Park, Hsinchu City 300,
Taiwan R.O.C.

Test Location (1): E-2, No.1, Li Hsin 1st Road, Hsinchu Science Park, Hsinchu City 300,
Taiwan R.O.C.

Test Location (2): No. 49, Ln. 206, Wende Rd., Shangshan Tsuen, Chiung Lin Hsiang, Hsin
Chu Hsien 307, Taiwan R.O.C.



This report is for your exclusive use. Any copying or replication of this report to or for any other person or entity, or use of our name or trademark, is permitted only with our prior written permission. This report sets forth our findings solely with respect to the test samples identified herein. The results set forth in this report are not indicative or representative of the quality or characteristics of the lot from which a test sample was taken or any similar or identical product unless specifically and expressly noted. Our report includes all of the tests requested by you and the results thereof based upon the information that you provided to us. You have 60 days from date of issuance of this report to notify us of any material error or omission caused by our negligence, provided, however, that such notice shall be in writing and shall specifically address the issue you wish to raise. A failure to raise such issue within the prescribed time shall constitute your unqualified acceptance of the completeness of this report, the tests conducted and the correctness of the report contents. Unless specific mention, the uncertainty of measurement has been explicitly taken into account to declare the compliance or non-compliance to the specification. The report must not be used by the client to claim product certification, approval, or endorsement by TAF or any government agencies.

Table of Contents

Release Control Record	4
1 Certificate of Conformity	5
2 Summary of Test Results	6
2.1 Measurement Uncertainty	6
2.2 Modification Record	6
3 General Information	7
3.1 General Description of EUT	7
3.2 Description of Test Modes	10
3.2.1 Test Mode Applicability and Tested Channel Detail	11
3.3 Duty Cycle of Test Signal	13
3.4 Description of Support Units	14
3.4.1 Configuration of System under Test	15
3.5 General Description of Applied Standards	16
4 Test Types and Results	17
4.1 Radiated Emission and Bandedge Measurement	17
4.1.1 Limits of Radiated Emission and Bandedge Measurement	17
4.1.2 Test Instruments	18
4.1.3 Test Procedures	19
4.1.4 Deviation from Test Standard	19
4.1.5 Test Setup	20
4.1.6 EUT Operating Conditions	20
4.1.7 Test Results (Bandedge)	21
4.1.8 Test Results (Spurious emission)	87
4.2 Conducted Emission Measurement	121
4.2.1 Limits of Conducted Emission Measurement	121
4.2.2 Test Instruments	121
4.2.3 Test Procedures	122
4.2.4 Deviation from Test Standard	122
4.2.5 Test Setup	122
4.2.6 EUT Operating Conditions	122
4.2.7 Test Results	123
4.3 6dB Bandwidth Measurement	125
4.3.1 Limits of 6dB Bandwidth Measurement	125
4.3.2 Test Setup	125
4.3.3 Test Instruments	125
4.3.4 Test Procedure	125
4.3.5 Deviation from Test Standard	125
4.3.6 EUT Operating Conditions	125
4.3.7 Test Result	126
4.4 Conducted Output Power Measurement	130
4.4.1 Limits of Conducted Output Power Measurement	130
4.4.2 Test Setup	130
4.4.3 Test Instruments	130
4.4.4 Test Procedures	130
4.4.5 Deviation from Test Standard	130
4.4.6 EUT Operating Conditions	130
4.4.7 Test Results	131
4.5 Power Spectral Density Measurement	134
4.5.1 Limits of Power Spectral Density Measurement	134
4.5.2 Test Setup	134
4.5.3 Test Instruments	134
4.5.4 Test Procedure	134
4.5.5 Deviation from Test Standard	134



4.5.6 EUT Operating Condition	134
4.5.7 Test Results	135
4.6 Conducted Out of Band Emission Measurement	139
4.6.1 Limits of Conducted Out of Band Emission Measurement.....	139
4.6.2 Test Setup.....	139
4.6.3 Test Instruments	139
4.6.4 Test Procedure	139
4.6.5 Deviation from Test Standard	139
4.6.6 EUT Operating Condition	139
4.6.7 Test Results	139
5 Pictures of Test Arrangements.....	154
Appendix – Information on the Testing Laboratories	155



A D T

Release Control Record

Issue No.	Description	Date Issued
RF160314E01	Original release.	May 23, 2016



1 Certificate of Conformity

Product: Integrated Device
Brand: Technicolor
Test Model: TCA300COM
Sample Status: ENGINEERING SAMPLE
Applicant: Technicolor Connected Home USA LLC
Test Date: Apr. 27 to 29, 2016
Standards: 47 CFR FCC Part 15, Subpart C (Section 15.247)
ANSI C63.10: 2013

The above equipment has been tested by **Bureau Veritas Consumer Products Services (H.K.) Ltd., Taoyuan Branch**, and found compliance with the requirement of the above standards. The test record, data evaluation & Equipment Under Test (EUT) configurations represented herein are true and accurate accounts of the measurements of the sample's EMC characteristics under the conditions specified in this report.

Prepared by : Wendy Wu. , **Date:** May 23, 2016
Wendy Wu / Specialist

Approved by : May Chen , **Date:** May 23, 2016
May Chen / Manager

2 Summary of Test Results

47 CFR FCC Part 15, Subpart C (SECTION 15.247)			
FCC Clause	Test Item	Result	Remarks
15.207	AC Power Conducted Emission	PASS	Meet the requirement of limit. Minimum passing margin is -11.35dB at 0.28087MHz.
15.205 / 15.209 / 15.247(d)	Radiated Emissions and Band Edge Measurement	PASS	Meet the requirement of limit. Minimum passing margin is -0.1dB at 2390.00MHz and 2483.00MHz.
15.247(d)	Antenna Port Emission	PASS	Meet the requirement of limit.
15.247(a)(2)	6dB bandwidth	PASS	Meet the requirement of limit.
15.247(b)	Conducted power	PASS	Meet the requirement of limit.
15.247(e)	Power Spectral Density	PASS	Meet the requirement of limit.
15.203	Antenna Requirement	PASS	Antenna connector are i-pex (MHF) and Pogo pin not a standard connector.

NOTE: 1. For WLAN: The EUT was operating in 2.412 ~ 2.462GHz, 5.18~5.24GHz, 5.26~5.32GHz, 5.50~5.70GHz and 5.745~5.825GHz frequencies band. This report was recorded the RF parameters including 2.412 ~ 2.462GHz. For the 5.18~5.24GHz, 5.26~5.32GHz, 5.50~5.70GHz and 5.745~5.825GHz RF parameters was recorded in another test report.

2.1 Measurement Uncertainty

Where relevant, the following measurement uncertainty levels have been estimated for tests performed on the EUT as specified in CISPR 16-4-2:

Measurement	Frequency	Expanded Uncertainty (k=2) (\pm)
Conducted Emissions at mains ports	150kHz ~ 30MHz	1.83 dB
Radiated Emissions up to 1 GHz	30MHz ~ 1GHz	5.31 dB
Radiated Emissions above 1 GHz	1GHz ~ 6GHz	3.40 dB
	6GHz ~ 18GHz	3.73 dB
	18GHz ~ 40GHz	4.11 dB

2.2 Modification Record

There were no modifications required for compliance.

3 General Information

3.1 General Description of EUT

Product	Integrated Device
Brand	Technicolor
Test Model	TCA300COM
Status of EUT	ENGINEERING SAMPLE
Power Supply Rating	12Vdc from power adapter or 4Vdc from battery
Modulation Type	CCK, DQPSK, DBPSK for DSSS 64QAM, 16QAM, QPSK, BPSK for OFDM
Modulation Technology	DSSS, OFDM
Transfer Rate	802.11b: up to 11Mbps 802.11a/g: up to 54Mbps 802.11n: up to 300Mbps
Operating Frequency	For 15.407: 5.18~5.24GHz, 5.26~5.32GHz, 5.50~5.70GHz, 5.745~5.825GHz
	For 15.247: 2.412 ~ 2.462GHz
Number of Channel	For 15.407: 802.11a, 802.11n (20MHz): 24 802.11n (40MHz): 11
	For 15.247: 802.11b, 802.11g, 802.11n (20MHz): 11 802.11n (40MHz): 7
Output Power	For 15.407: 1TX Antenna Combination-WiFi 1 5.18~5.24GHz 125.026mW 5.26~5.32GHz 122.462mW 5.50~5.70GHz 91.622mW 5.745~5.825GHz 94.624mW Antenna Combination-WiFi 2 5.18~5.24GHz 108.143mW 5.26~5.32GHz 110.662mW 5.50~5.70GHz 73.451mW 5.745~5.825GHz 67.92mW 2TX 5.18~5.24GHz 229.018mW 5.26~5.32GHz 227.54mW 5.50~5.70GHz 156.97mW 5.745~5.825GHz 150.418mW

	For 15.247: 1TX Antenna Combination-WiFi 1 127.644mW Antenna Combination-WiFi 2 125.314mW 2TX 126.409mW
Antenna Type	Refer to Note
Antenna Connector	Refer to Note
Accessory Device	Adapter x1 Battery x1
Data Cable Supplied	NA
HW Version	FGR

Note:

1. There are WLAN, Bluetooth, Zigbee and WWAN(3G) technology used for the EUT.
2. The EUT power needs to be supplied from one power adapter or battery, the information is as below table:

Adapter		
Brand	Model	Spec.
XHPSU-TC	37469780	Input: 100-120Vac, 50/60Hz, 0.7A Output: 12V, 1.5A DC output cable (Unshielded, 3m)
Battery		
Brand	Model	Spec.
Li-polymer	U46P313.00	4V, 2520mAh, 10.08Wh

3. The antennas provided to the EUT, please refer to the following table:

Antenna NO.	Brand	Antenna Gain(dBi) (Including cable loss)	Frequency range (GHz)	Antenna Type	Connector Type
Zigbee 1	INPAQ	2.84	2.4~2.4835GHz	PCB	i-pex(MHF)
Zigbee 2	INPAQ	3.1	2.4~2.4835GHz	PCB	i-pex(MHF)
WiFi 1	INPAQ	2.06	2.4~2.4835GHz	PCB	Pogo pin
		3.13	5.15~5.25GHz		
		3.79	5.25~5.35GHz		
		3.9	5.47~5.725GHz		
		2.39	5.725~5.85GHz		
WiFi 2	INPAQ	0.73	2.4~2.4835GHz	PCB	i-pex(MHF)
		2.86	5.15~5.25GHz		
		3.02	5.25~5.35GHz		
		3.33	5.47~5.725GHz		
WWAN	INPAQ	2.56	824~849MHz	PCB	Pogo pin
		3.72	1850~1960MHz		

4. The EUT incorporates a MIMO function.

2.4GHz Band			
MODULATION MODE	DATA RATE (MCS)	TX & RX CONFIGURATION	
802.11b	1 ~ 11Mbps	1TX diversity	2RX
802.11g	6 ~ 54Mbps	1TX diversity / 2TX	2RX
802.11n (20MHz)	MCS 0~7	1TX diversity / 2TX	2RX
	MCS 8~15	2TX	2RX
802.11n (40MHz)	MCS 0~7	1TX diversity / 2TX	2RX
	MCS 8~15	2TX	2RX
5GHz Band			
MODULATION MODE	DATA RATE (MCS)	TX & RX CONFIGURATION	
802.11a	6 ~ 54Mbps	1TX diversity / 2TX	2RX
802.11n (20MHz)	MCS 0~7	1TX diversity / 2TX	2RX
	MCS 8~15	2TX	2RX
802.11n (40MHz)	MCS 0~7	1TX diversity / 2TX	2RX
	MCS 8~15	2TX	2RX

5. The above EUT information is declared by manufacturer and for more detailed features description, please refer to the manufacturer's specifications or user's manual.

3.2 Description of Test Modes

11 channels are provided for 802.11b, 802.11g and 802.11n (20MHz):

Channel	Frequency	Channel	Frequency
1	2412MHz	7	2442MHz
2	2417MHz	8	2447MHz
3	2422MHz	9	2452MHz
4	2427MHz	10	2457MHz
5	2432MHz	11	2462MHz
6	2437MHz		

7 channels are provided for 802.11n (40MHz):

Channel	Frequency	Channel	Frequency
3	2422MHz	7	2442MHz
4	2427MHz	8	2447MHz
5	2432MHz	9	2452MHz
6	2437MHz		

3.2.1 Test Mode Applicability and Tested Channel Detail

EUT CONFIGURE MODE	APPLICABLE TO				DESCRIPTION
	RE \geq 1G	RE $<$ 1G	PLC	APCM	
-	√	√	√	√	-

Where **RE \geq 1G**: Radiated Emission above 1GHz & Bandedge Measurement
RE $<$ 1G: Radiated Emission below 1GHz
PLC: Power Line Conducted Emission
APCM: Antenna Port Conducted Measurement

NOTE: The EUT had been pre-tested on the positioned of each 3 axis. The worst case was found when positioned on **Y-plane**.

Radiated Emission Test (Above 1GHz):

- Pre-Scan has been conducted to determine the worst-case mode from all possible combinations between available modulations, data rates and antenna ports (if EUT with antenna diversity architecture).
- Following channel(s) was (were) selected for the final test as listed below.

1TX					
Antenna 1					
MODE	AVAILABLE CHANNEL	TESTED CHANNEL	MODULATION TECHNOLOGY	MODULATION TYPE	DATA RATE (Mbps)
802.11b	1 to 11	1, 6, 11	DSSS	DBPSK	1
802.11g	1 to 11	1, 6, 11	OFDM	BPSK	6
802.11n (20MHz)	1 to 11	1, 6, 11	OFDM	BPSK	6.5
802.11n (40MHz)	3 to 9	3, 6, 9	OFDM	BPSK	13.5
Antenna 2					
MODE	AVAILABLE CHANNEL	TESTED CHANNEL	MODULATION TECHNOLOGY	MODULATION TYPE	DATA RATE (Mbps)
802.11b	1 to 11	1, 6, 11	DSSS	DBPSK	1
802.11g	1 to 11	1, 6, 11	OFDM	BPSK	6
802.11n (20MHz)	1 to 11	1, 6, 11	OFDM	BPSK	6.5
802.11n (40MHz)	3 to 9	3, 6, 9	OFDM	BPSK	13.5
2TX CDD Mode					
MODE	AVAILABLE CHANNEL	TESTED CHANNEL	MODULATION TECHNOLOGY	MODULATION TYPE	DATA RATE (Mbps)
802.11g	1 to 11	1, 6, 11	OFDM	BPSK	6
802.11n (20MHz)	1 to 11	1, 6, 11	OFDM	BPSK	6.5
802.11n (40MHz)	3 to 9	3, 6, 9	OFDM	BPSK	13.5

Radiated Emission Test (Below 1GHz):

- Pre-Scan has been conducted to determine the worst-case mode from all possible combinations between available modulations, data rates and antenna ports (if EUT with antenna diversity architecture).
- Following channel(s) was (were) selected for the final test as listed below.

2TX CDD Mode					
MODE	AVAILABLE CHANNEL	TESTED CHANNEL	MODULATION TECHNOLOGY	MODULATION TYPE	DATA RATE (Mbps)
802.11g	1 to 11	6	OFDM	BPSK	6

Power Line Conducted Emission Test:

- Pre-Scan has been conducted to determine the worst-case mode from all possible combinations between available modulations, data rates and antenna ports (if EUT with antenna diversity architecture).
- Following channel(s) was (were) selected for the final test as listed below.

2TX CDD Mode					
MODE	AVAILABLE CHANNEL	TESTED CHANNEL	MODULATION TECHNOLOGY	MODULATION TYPE	DATA RATE (Mbps)
802.11g	1 to 11	6	OFDM	BPSK	6

Antenna Port Conducted Measurement:

- This item includes all test value of each mode, but only includes spectrum plot of worst value of each mode.
- Pre-Scan has been conducted to determine the worst-case mode from all possible combinations between available modulations, data rates and antenna ports (if EUT with antenna diversity architecture).
- Following channel(s) was (were) selected for the final test as listed below.

1TX					
Antenna 1					
MODE	AVAILABLE CHANNEL	TESTED CHANNEL	MODULATION TECHNOLOGY	MODULATION TYPE	DATA RATE (Mbps)
802.11b	1 to 11	1, 6, 11	DSSS	DBPSK	1
802.11g	1 to 11	1, 6, 11	OFDM	BPSK	6
802.11n (20MHz)	1 to 11	1, 6, 11	OFDM	BPSK	6.5
802.11n (40MHz)	3 to 9	3, 6, 9	OFDM	BPSK	13.5
Antenna 2					
MODE	AVAILABLE CHANNEL	TESTED CHANNEL	MODULATION TECHNOLOGY	MODULATION TYPE	DATA RATE (Mbps)
802.11b	1 to 11	1, 6, 11	DSSS	DBPSK	1
802.11g	1 to 11	1, 6, 11	OFDM	BPSK	6
802.11n (20MHz)	1 to 11	1, 6, 11	OFDM	BPSK	6.5
802.11n (40MHz)	3 to 9	3, 6, 9	OFDM	BPSK	13.5
2TX CDD Mode					
MODE	AVAILABLE CHANNEL	TESTED CHANNEL	MODULATION TECHNOLOGY	MODULATION TYPE	DATA RATE (Mbps)
802.11g	1 to 11	1, 6, 11	OFDM	BPSK	6
802.11n (20MHz)	1 to 11	1, 6, 11	OFDM	BPSK	6.5
802.11n (40MHz)	3 to 9	3, 6, 9	OFDM	BPSK	13.5

Note : Antenna 2 were performed output power measurement only.

Test Condition:

APPLICABLE TO	ENVIRONMENTAL CONDITIONS	INPUT POWER	TESTED BY	TEST LOCATION
RE\geq1G	25deg. C, 65%RH	120Vac, 60Hz	Chris Lin	1
RE$<$1G	25deg. C, 65%RH	120Vac, 60Hz	Chris Lin	1
PLC	25deg. C, 68%RH	120Vac, 60Hz	Sun Lin	2
APCM	21deg. C, 60%RH	120Vac, 60Hz	Nick Chen	1

3.3 Duty Cycle of Test Signal

Duty cycle of test signal is $\geq 98\%$, duty factor is not required.

802.11b: Duty cycle = $12.45/12.494 = 0.996$

802.11g: Duty cycle = $2.065/2.093 = 0.987$

802.11n (20MHz): Duty cycle = $1.919/1.95 = 0.984$

802.11n (40MHz): Duty cycle = $0.955/0.974 = 0.982$

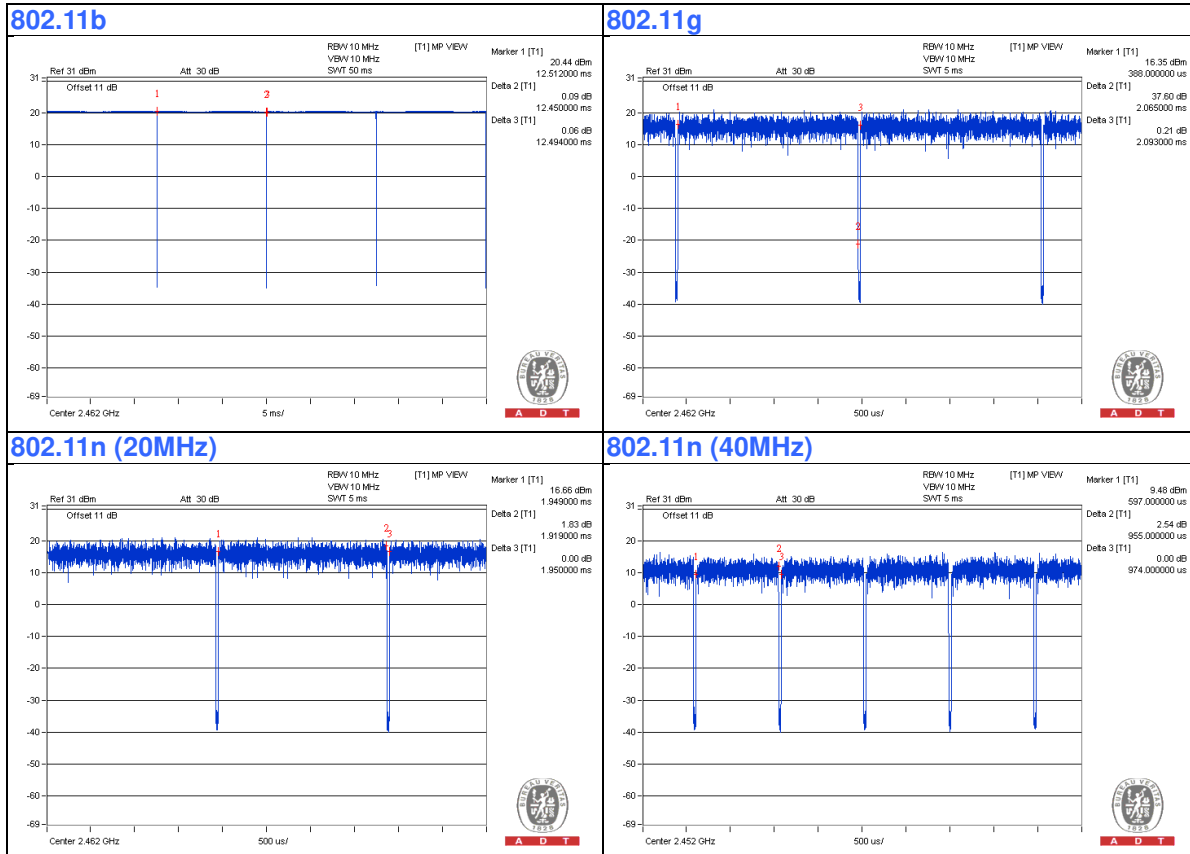

3.4 Description of Support Units

The EUT has been tested as an independent unit together with other necessary accessories or support units. The following support units or accessories were used to form a representative test configuration during the tests.

ID	Product	Brand	Model No.	Serial No.	FCC ID	Remarks
A.	Notebook Computer	DELL	E5430	HYV4VY1	FCC DoC	Provided by Lab
B.	Sim Card	R&S	CRT-Z3	NA	NA	Provided by Lab
C.	Simulator	R&S	CMU200	121040	NA	Provided by Lab

Note:

1. All power cords of the above support units are non-shielded (1.8m).

ID	Descriptions	Qty.	Length (m)	Shielding (Yes/No)	Cores (Qty.)	Remarks
1.	RJ45 cable	1	10	No	0	Provided by Lab
2.	DC cable	1	3	No	0	Supplied by Client

3.4.1 Configuration of System under Test

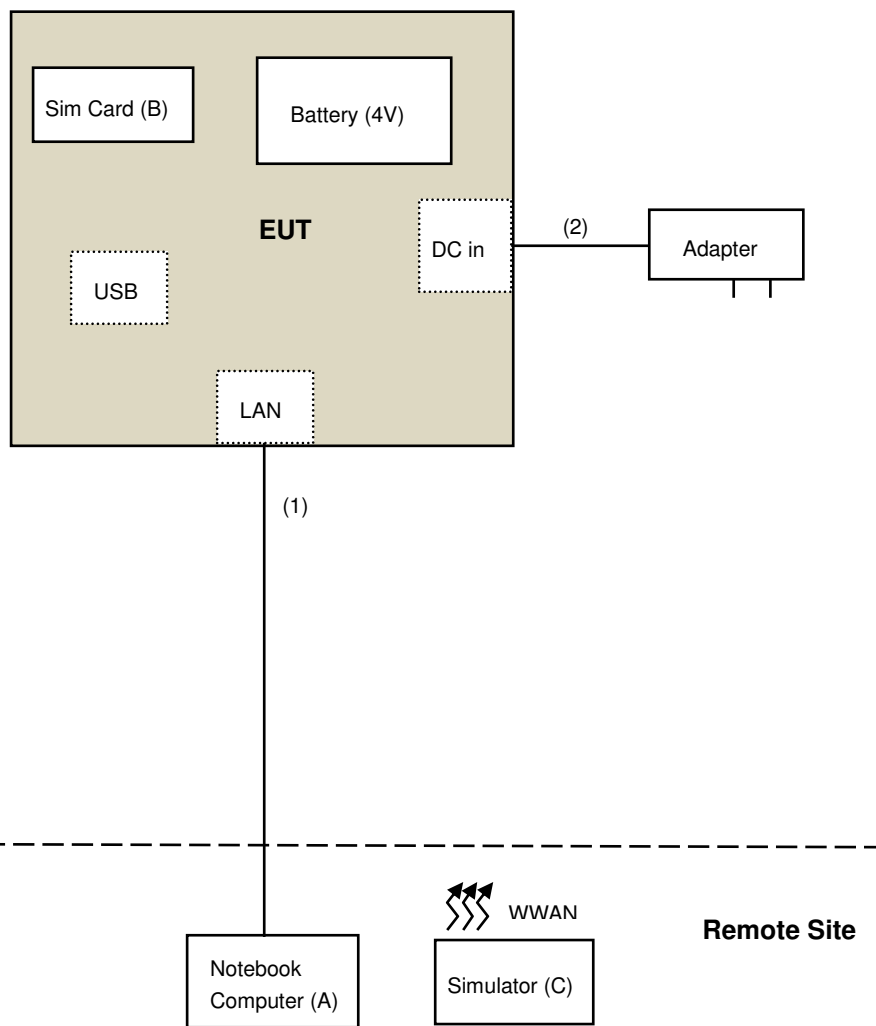

3.5 General Description of Applied Standards

The EUT is a RF Product. According to the specifications of the manufacturer, it must comply with the requirements of the following standards:

FCC Part 15, Subpart C (15.247)

KDB 558074 D01 DTS Meas Guidance v03r05

KDB 662911 D01 Multiple Transmitter Output v02r01

ANSI C63.10-2013

All test items have been performed and recorded as per the above standards.

4 Test Types and Results

4.1 Radiated Emission and Bandedge Measurement

4.1.1 Limits of Radiated Emission and Bandedge Measurement

Radiated emissions which fall in the restricted bands must comply with the radiated emission limits specified as below table. Other emissions shall be at least 30dB below the highest level of the desired power:

Frequencies (MHz)	Field Strength (microvolts/meter)	Measurement Distance (meters)
0.009 ~ 0.490	2400/F(kHz)	300
0.490 ~ 1.705	24000/F(kHz)	30
1.705 ~ 30.0	30	30
30 ~ 88	100	3
88 ~ 216	150	3
216 ~ 960	200	3
Above 960	500	3

NOTE:

1. The lower limit shall apply at the transition frequencies.
2. Emission level (dBuV/m) = 20 log Emission level (uV/m).
3. For frequencies above 1000MHz, the field strength limits are based on average detector, however, the peak field strength of any emission shall not exceed the maximum permitted average limits, specified above by more than 20dB under any condition of modulation.



A D T

4.1.2 Test Instruments

DESCRIPTION & MANUFACTURER	MODEL NO.	SERIAL NO.	CALIBRATED DATE	CALIBRATED UNTIL
Test Receiver Agilent	N9038A	MY50010156	Aug. 12, 2015	Aug. 11, 2016
Pre-Amplifier ^(*) EMCI	EMC001340	980142	Jan. 20, 2016	Jan. 19, 2018
Loop Antenna ^(*) Electro-Metrics	EM-6879	264	Dec. 16, 2014	Dec. 15, 2016
RF Cable	NA	LOOPCAB-001 LOOPCAB-002	Jan. 18, 2016	Jan. 17, 2017
Pre-Amplifier Mini-Circuits	ZFL-1000VH2B	AMP-ZFL-07	May 08, 2015	May 07, 2016
Trilog Broadband Antenna SCHWARZBECK	VULB 9168	9168-156	Jan. 04, 2016	Jan. 03, 2017
RF Cable	8D	966-3-1 966-3-2 966-3-3	Apr. 02, 2016	Apr. 01, 2017
Horn_Antenna SCHWARZBECK	BBHA9120-D	9120D-406	Jan. 20, 2016	Jan. 19, 2017
Pre-Amplifier Agilent	8449B	3008A02465	Apr. 05, 2016	Apr. 04, 2017
RF Cable	EMC104-SM-SM-2000 EMC104-SM-SM-5000 EMC104-SM-SM-5000	150317 150321 150322	Mar. 30, 2016	Mar. 29, 2017
Spectrum Analyzer Keysight	N9030A	MY54490520	July 26, 2015	July 25, 2016
Pre-Amplifier EMCI	EMC184045	980143	Jan. 15, 2016	Jan. 14, 2017
Horn_Antenna SCHWARZBECK	BBHA 9170	BBHA9170608	Jan. 08, 2016	Jan. 07, 2017
RF Cable	SUCOFLEX 102	36432/2 36441/2	Jan. 16, 2016	Jan. 15, 2017
Software	ADT_Radiated_V8.7.07	NA	NA	NA
Antenna Tower & Turn Table CT	NA	NA	NA	NA
Boresight Antenna Fixture	NA	NA	NA	NA
SPECTRUM ANALYZER R&S	FSP 40	100060	May 08, 2015	May 07, 2016
Power meter Anritsu	ML2495A	0824006	May 25, 2015	May 24, 2016
Power sensor Anritsu	MA2411B	0738172	May 25, 2015	May 24, 2016

Note:

1. The calibration interval of the above test instruments is 12 months and the calibrations are traceable to NML/ROC and NIST/USA.
2. *The calibration interval of the above test instruments is 24 months and the calibrations are traceable to NML/ROC and NIST/USA.
Loop antenna was used for all emissions below 30 MHz.
3. The test was performed in 966 Chamber No. 3.
4. The FCC Site Registration No. is 147459
6. The CANADA Site Registration No. is 20331-1
8. Tested Date: Apr. 28 to 29, 2016

4.1.3 Test Procedures

- a. The EUT was placed on the top of a rotating table 0.8 meters (for below 1GHz) / 1.5 meters (for above 1GHz) above the ground at 3 meter chamber room for test. The table was rotated 360 degrees to determine the position of the highest radiation.
- b. The EUT was set 3 meters away from the interference-receiving antenna, which was mounted on the top of a variable-height antenna tower.
- c. The height of antenna is varied from one meter to four meters above the ground to determine the maximum value of the field strength. Both horizontal and vertical polarizations of the antenna are set to make the measurement.
- d. For each suspected emission, the EUT was arranged to its worst case and then the antenna was tuned to heights from 1 meter to 4 meters and the rotatable table was turned from 0 degrees to 360 degrees to find the maximum reading.
- e. The test-receiver system was set to quasi-peak detect function and specified bandwidth with maximum hold mode when the test frequency is below 1 GHz.
- f. The test-receiver system was set to peak and average detect function and specified bandwidth with maximum hold mode when the test frequency is above 1 GHz. If the peak reading value also meets average limit, measurement with the average detector is unnecessary.

Note:

1. The resolution bandwidth and video bandwidth of test receiver/spectrum analyzer is 120kHz for Quasi-peak detection (QP) at frequency below 1GHz.
2. The resolution bandwidth of test receiver/spectrum analyzer is 1 MHz and the video bandwidth is 3 MHz for Peak detection (PK) at frequency above 1GHz.
3. The resolution bandwidth of test receiver/spectrum analyzer is 1MHz and the video bandwidth is 3MHz for RMS Average (Duty cycle < 98%) for Average detection (AV) at frequency above 1GHz, then the measurement results was added to a correction factor ($10 \log(1/\text{duty cycle})$).
4. The resolution bandwidth of test receiver/spectrum analyzer is 1MHz and the video bandwidth is 10Hz (Duty cycle $\geq 98\%$) for Average detection (AV) at frequency above 1GHz.
5. All modes of operation were investigated and the worst-case emissions are reported.

4.1.4 Deviation from Test Standard

No deviation.

4.1.5 Test Setup

<Frequency Range below 1GHz>

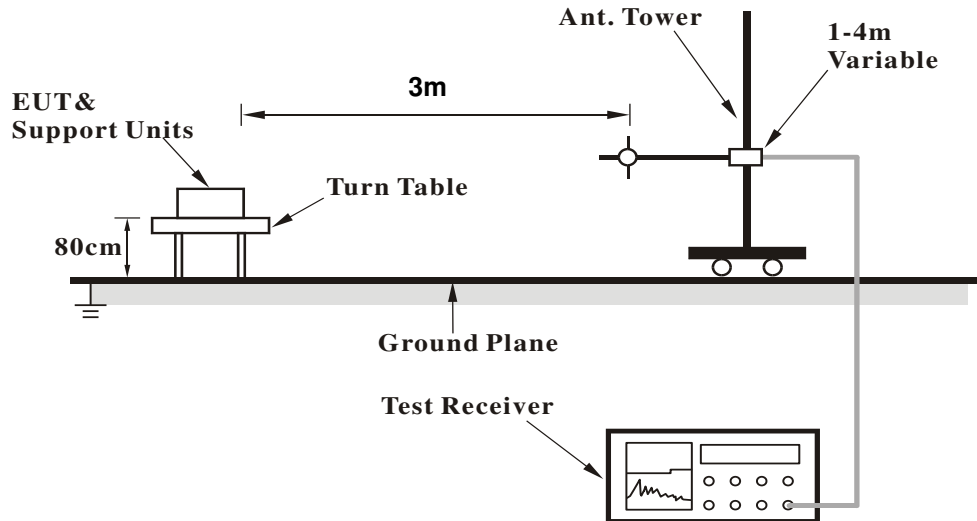

<Frequency Range above 1GHz>

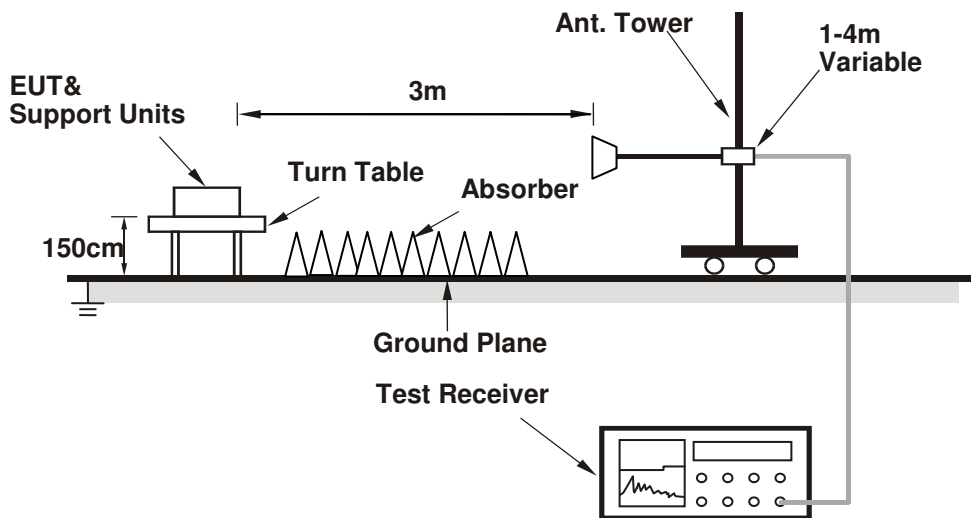

For the actual test configuration, please refer to the attached file (Test Setup Photo).

4.1.6 EUT Operating Conditions

1. Connect the EUT with the support unit A (Notebook Computer) which is placed on test table.
2. The communication partner run test program “adb.exe [Android 4.4.2]” to enable EUT under transmission/receiving condition continuously at specific channel frequency.

4.1.7 Test Results (Bandedge)

Antenna 1

802.11b

CHANNEL	TX Channel 1	DETECTOR FUNCTION	Peak (PK)
FREQUENCY RANGE	1GHz ~ 25GHz		Average (AV)

ANTENNA POLARITY & TEST DISTANCE: HORIZONTAL AT 3 M								
NO.	FREQ. (MHz)	EMISSION LEVEL (dBuV/m)	LIMIT (dBuV/m)	MARGIN (dB)	ANTENNA HEIGHT (m)	TABLE ANGLE (Degree)	RAW VALUE (dBuV)	CORRECTION FACTOR (dB/m)
1	2387.00	56.2 PK	74.0	-17.8	1.00 H	94	60.44	-4.24
2	2387.00	50.4 AV	54.0	-3.6	1.00 H	94	54.64	-4.24
3	*2412.00	103.8 PK			1.00 H	94	107.96	-4.16
4	*2412.00	101.7 AV			1.00 H	94	105.86	-4.16

REMARKS:

1. Emission Level(dBuV/m) = Raw Value(dBuV) + Correction Factor(dB/m)
2. Correction Factor(dB/m) = Antenna Factor(dB/m) + Cable Factor(dB) – Pre-Amplifier Factor(dB)
3. The other emission levels were very low against the limit.
4. Margin value = Emission Level – Limit value
5. " * ": Fundamental frequency.

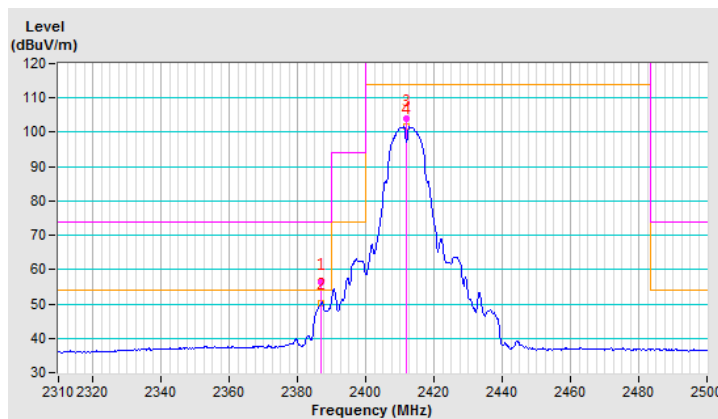

Antenna 1

CHANNEL	TX Channel 1	DETECTOR FUNCTION	Peak (PK)
FREQUENCY RANGE	1GHz ~ 25GHz		Average (AV)

ANTENNA POLARITY & TEST DISTANCE: VERTICAL AT 3 M								
NO.	FREQ. (MHz)	EMISSION LEVEL (dBuV/m)	LIMIT (dBuV/m)	MARGIN (dB)	ANTENNA HEIGHT (m)	TABLE ANGLE (Degree)	RAW VALUE (dBuV)	CORRECTION FACTOR (dB/m)
1	2387.00	57.9 PK	74.0	-16.1	1.00 V	82	62.14	-4.24
2	2387.00	52.7 AV	54.0	-1.3	1.00 V	82	56.94	-4.24
3	*2412.00	107.6 PK			1.00 V	82	111.76	-4.16
4	*2412.00	105.5 AV			1.00 V	82	109.66	-4.16

REMARKS:

1. Emission Level(dBuV/m) = Raw Value(dBuV) + Correction Factor(dB/m)
2. Correction Factor(dB/m) = Antenna Factor(dB/m) + Cable Factor(dB) – Pre-Amplifier Factor(dB)
3. The other emission levels were very low against the limit.
4. Margin value = Emission Level – Limit value
5. " * ": Fundamental frequency.

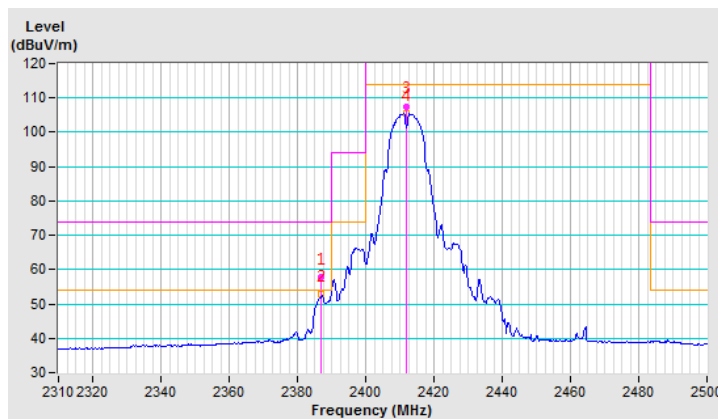

Antenna 1

CHANNEL	TX Channel 6	DETECTOR FUNCTION	Peak (PK)
FREQUENCY RANGE	1GHz ~ 25GHz		Average (AV)

ANTENNA POLARITY & TEST DISTANCE: HORIZONTAL AT 3 M								
NO.	FREQ. (MHz)	EMISSION LEVEL (dBuV/m)	LIMIT (dBuV/m)	MARGIN (dB)	ANTENNA HEIGHT (m)	TABLE ANGLE (Degree)	RAW VALUE (dBuV)	CORRECTION FACTOR (dB/m)
1	2390.00	50.4 PK	74.0	-23.6	1.00 H	82	54.63	-4.23
2	2390.00	39.1 AV	54.0	-14.9	1.00 H	82	43.33	-4.23
3	*2437.00	110.1 PK			1.00 H	82	114.19	-4.09
4	*2437.00	107.7 AV			1.00 H	82	111.79	-4.09
5	2483.50	53.9 PK	74.0	-20.1	1.00 H	82	57.85	-3.95
6	2483.50	41.1 AV	54.0	-12.9	1.00 H	82	45.05	-3.95

REMARKS:

1. Emission Level(dBuV/m) = Raw Value(dBuV) + Correction Factor(dB/m)
2. Correction Factor(dB/m) = Antenna Factor(dB/m) + Cable Factor(dB) – Pre-Amplifier Factor(dB)
3. The other emission levels were very low against the limit.
4. Margin value = Emission Level – Limit value
5. " * ": Fundamental frequency.

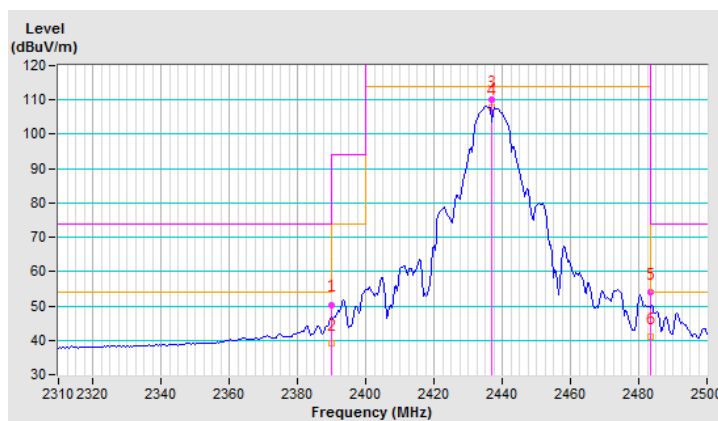

Antenna 1

CHANNEL	TX Channel 6	DETECTOR FUNCTION	Peak (PK)
FREQUENCY RANGE	1GHz ~ 25GHz		Average (AV)

ANTENNA POLARITY & TEST DISTANCE: VERTICAL AT 3 M								
NO.	FREQ. (MHz)	EMISSION LEVEL (dBuV/m)	LIMIT (dBuV/m)	MARGIN (dB)	ANTENNA HEIGHT (m)	TABLE ANGLE (Degree)	RAW VALUE (dBuV)	CORRECTION FACTOR (dB/m)
1	2390.00	54.2 PK	74.0	-19.8	2.02 V	360	58.43	-4.23
2	2390.00	45.3 AV	54.0	-8.7	2.02 V	360	49.53	-4.23
3	*2437.00	110.4 PK			2.02 V	360	114.49	-4.09
4	*2437.00	108.1 AV			2.02 V	360	112.19	-4.09
5	2483.50	56.7 PK	74.0	-17.3	2.02 V	360	60.65	-3.95
6	2483.50	49.2 AV	54.0	-4.8	2.02 V	360	53.15	-3.95

REMARKS:

1. Emission Level(dBuV/m) = Raw Value(dBuV) + Correction Factor(dB/m)
2. Correction Factor(dB/m) = Antenna Factor(dB/m) + Cable Factor(dB) – Pre-Amplifier Factor(dB)
3. The other emission levels were very low against the limit.
4. Margin value = Emission Level – Limit value
5. " * ": Fundamental frequency.

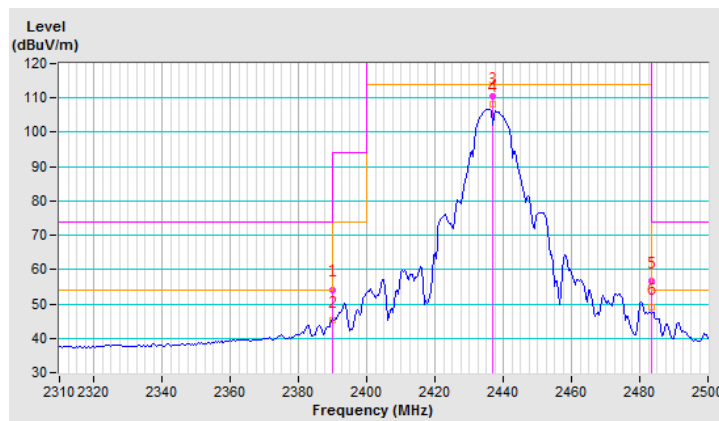

Antenna 1

CHANNEL	TX Channel 11	DETECTOR FUNCTION	Peak (PK)
FREQUENCY RANGE	1GHz ~ 25GHz		Average (AV)

ANTENNA POLARITY & TEST DISTANCE: HORIZONTAL AT 3 M								
NO.	FREQ. (MHz)	EMISSION LEVEL (dBuV/m)	LIMIT (dBuV/m)	MARGIN (dB)	ANTENNA HEIGHT (m)	TABLE ANGLE (Degree)	RAW VALUE (dBuV)	CORRECTION FACTOR (dB/m)
1	*2462.00	107.6 PK			1.00 H	78	111.61	-4.01
2	*2462.00	105.5 AV			1.00 H	78	109.51	-4.01
3	2483.50	58.7 PK	74.0	-15.3	1.00 H	78	62.65	-3.95
4	2483.50	53.7 AV	54.0	-0.3	1.00 H	78	57.65	-3.95

REMARKS:

1. Emission Level(dBuV/m) = Raw Value(dBuV) + Correction Factor(dB/m)
2. Correction Factor(dB/m) = Antenna Factor(dB/m) + Cable Factor(dB) – Pre-Amplifier Factor(dB)
3. The other emission levels were very low against the limit.
4. Margin value = Emission Level – Limit value
5. " * ": Fundamental frequency.

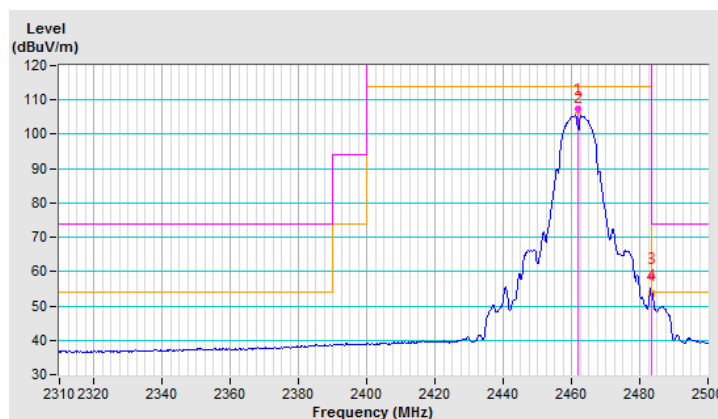

Antenna 1

CHANNEL	TX Channel 11	DETECTOR FUNCTION	Peak (PK)
FREQUENCY RANGE	1GHz ~ 25GHz		Average (AV)

ANTENNA POLARITY & TEST DISTANCE: VERTICAL AT 3 M								
NO.	FREQ. (MHz)	EMISSION LEVEL (dBuV/m)	LIMIT (dBuV/m)	MARGIN (dB)	ANTENNA HEIGHT (m)	TABLE ANGLE (Degree)	RAW VALUE (dBuV)	CORRECTION FACTOR (dB/m)
1	*2462.00	105.1 PK			1.00 V	82	109.11	-4.01
2	*2462.00	102.9 AV			1.00 V	82	106.91	-4.01
3	2483.50	56.1 PK	74.0	-17.9	1.00 V	82	60.05	-3.95
4	2483.50	50.6 AV	54.0	-3.4	1.00 V	82	54.55	-3.95

REMARKS:

1. Emission Level(dBuV/m) = Raw Value(dBuV) + Correction Factor(dB/m)
2. Correction Factor(dB/m) = Antenna Factor(dB/m) + Cable Factor(dB) – Pre-Amplifier Factor(dB)
3. The other emission levels were very low against the limit.
4. Margin value = Emission Level – Limit value
5. " * ": Fundamental frequency.

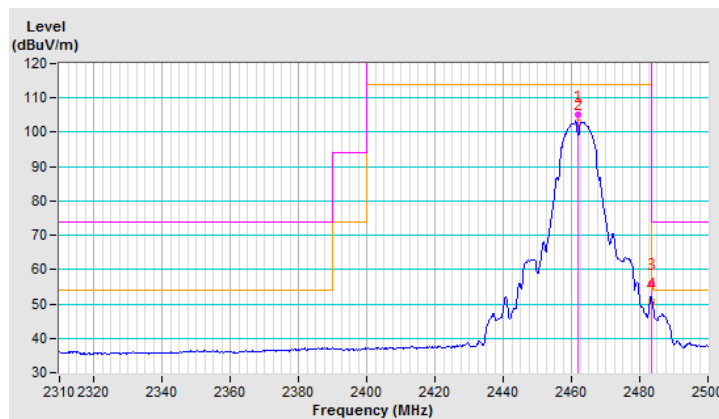

Antenna 1

802.11g

CHANNEL	TX Channel 1	DETECTOR FUNCTION	Peak (PK)
FREQUENCY RANGE	1GHz ~ 25GHz		Average (AV)

ANTENNA POLARITY & TEST DISTANCE: HORIZONTAL AT 3 M								
NO.	FREQ. (MHz)	EMISSION LEVEL (dBuV/m)	LIMIT (dBuV/m)	MARGIN (dB)	ANTENNA HEIGHT (m)	TABLE ANGLE (Degree)	RAW VALUE (dBuV)	CORRECTION FACTOR (dB/m)
1	2390.00	69.7 PK	74.0	-4.3	1.00 H	80	74.08	-4.38
2	2390.00	45.1 AV	54.0	-8.9	1.00 H	80	49.48	-4.38
3	*2412.00	106.9 PK			1.00 H	80	111.21	-4.31
4	*2412.00	94.9 AV			1.00 H	80	99.21	-4.31

REMARKS:

1. Emission Level(dBuV/m) = Raw Value(dBuV) + Correction Factor(dB/m)
2. Correction Factor(dB/m) = Antenna Factor(dB/m) + Cable Factor(dB) – Pre-Amplifier Factor(dB)
3. The other emission levels were very low against the limit.
4. Margin value = Emission Level – Limit value
5. " * ": Fundamental frequency.

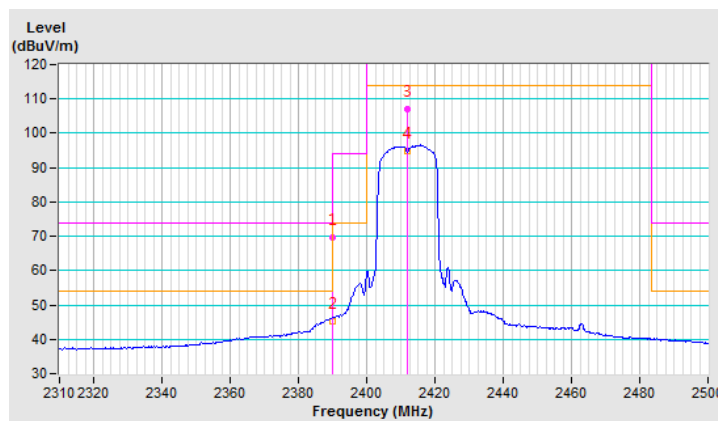

Antenna 1

CHANNEL	TX Channel 1	DETECTOR FUNCTION	Peak (PK)
FREQUENCY RANGE	1GHz ~ 25GHz		Average (AV)

ANTENNA POLARITY & TEST DISTANCE: VERTICAL AT 3 M								
NO.	FREQ. (MHz)	EMISSION LEVEL (dBuV/m)	LIMIT (dBuV/m)	MARGIN (dB)	ANTENNA HEIGHT (m)	TABLE ANGLE (Degree)	RAW VALUE (dBuV)	CORRECTION FACTOR (dB/m)
1	2390.00	73.9 PK	74.0	-0.1	1.82 V	360	78.13	-4.23
2	2390.00	52.9 AV	54.0	-1.1	1.82 V	360	57.13	-4.23
3	*2412.00	109.7 PK			1.82 V	360	113.86	-4.16
4	*2412.00	97.8 AV			1.82 V	360	101.96	-4.16

REMARKS:

1. Emission Level(dBuV/m) = Raw Value(dBuV) + Correction Factor(dB/m)
2. Correction Factor(dB/m) = Antenna Factor(dB/m) + Cable Factor(dB) – Pre-Amplifier Factor(dB)
3. The other emission levels were very low against the limit.
4. Margin value = Emission Level – Limit value
5. " * ": Fundamental frequency.

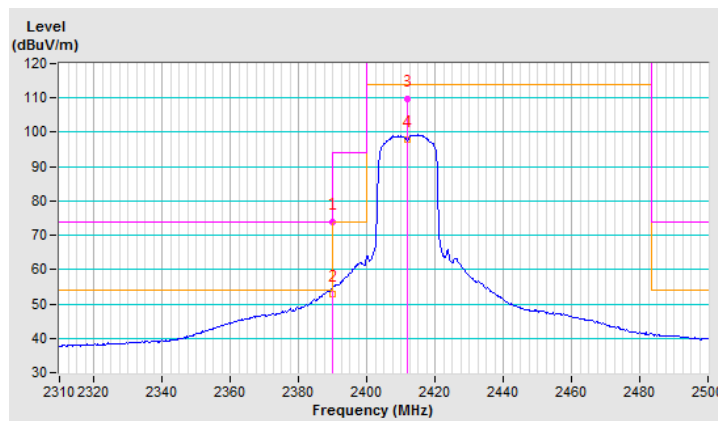

Antenna 1

CHANNEL	TX Channel 6	DETECTOR FUNCTION	Peak (PK)
FREQUENCY RANGE	1GHz ~ 25GHz		Average (AV)

ANTENNA POLARITY & TEST DISTANCE: HORIZONTAL AT 3 M								
NO.	FREQ. (MHz)	EMISSION LEVEL (dBuV/m)	LIMIT (dBuV/m)	MARGIN (dB)	ANTENNA HEIGHT (m)	TABLE ANGLE (Degree)	RAW VALUE (dBuV)	CORRECTION FACTOR (dB/m)
1	2390.00	65.5 PK	74.0	-8.5	1.00 H	85	69.88	-4.38
2	2390.00	45.4 AV	54.0	-8.6	1.00 H	85	49.78	-4.38
3	*2437.00	111.2 PK			1.00 H	85	115.44	-4.24
4	*2437.00	98.8 AV			1.00 H	85	103.04	-4.24
5	2483.50	70.1 PK	74.0	-3.9	1.00 H	85	74.19	-4.09
6	2483.50	46.7 AV	54.0	-7.3	1.00 H	85	50.79	-4.09

REMARKS:

1. Emission Level(dBuV/m) = Raw Value(dBuV) + Correction Factor(dB/m)
2. Correction Factor(dB/m) = Antenna Factor(dB/m) + Cable Factor(dB) – Pre-Amplifier Factor(dB)
3. The other emission levels were very low against the limit.
4. Margin value = Emission Level – Limit value
5. " * ": Fundamental frequency.

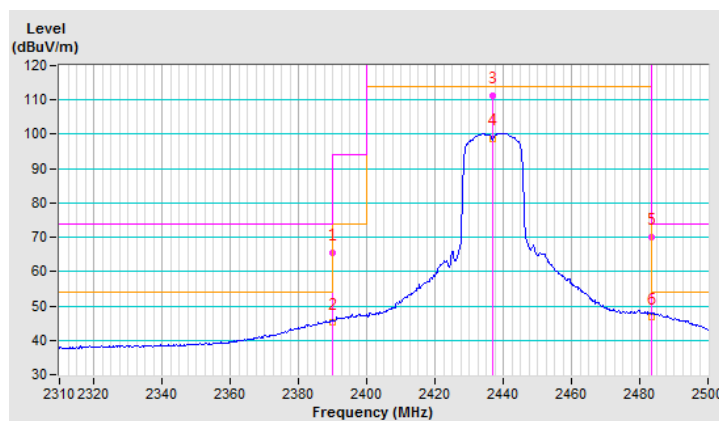

Antenna 1

CHANNEL	TX Channel 6	DETECTOR FUNCTION	Peak (PK)
FREQUENCY RANGE	1GHz ~ 25GHz		Average (AV)

ANTENNA POLARITY & TEST DISTANCE: VERTICAL AT 3 M								
NO.	FREQ. (MHz)	EMISSION LEVEL (dBuV/m)	LIMIT (dBuV/m)	MARGIN (dB)	ANTENNA HEIGHT (m)	TABLE ANGLE (Degree)	RAW VALUE (dBuV)	CORRECTION FACTOR (dB/m)
1	2390.00	71.0 PK	74.0	-3.0	1.80 V	360	75.23	-4.23
2	2390.00	52.7 AV	54.0	-1.3	1.80 V	360	56.93	-4.23
3	*2437.00	111.4 PK			1.80 V	360	115.49	-4.09
4	*2437.00	99.6 AV			1.80 V	360	103.69	-4.09
5	2483.50	69.8 PK	74.0	-4.2	1.80 V	360	73.75	-3.95
6	2483.50	50.7 AV	54.0	-3.3	1.80 V	360	54.65	-3.95

REMARKS:

1. Emission Level(dBuV/m) = Raw Value(dBuV) + Correction Factor(dB/m)
2. Correction Factor(dB/m) = Antenna Factor(dB/m) + Cable Factor(dB) – Pre-Amplifier Factor(dB)
3. The other emission levels were very low against the limit.
4. Margin value = Emission Level – Limit value
5. " * ": Fundamental frequency.

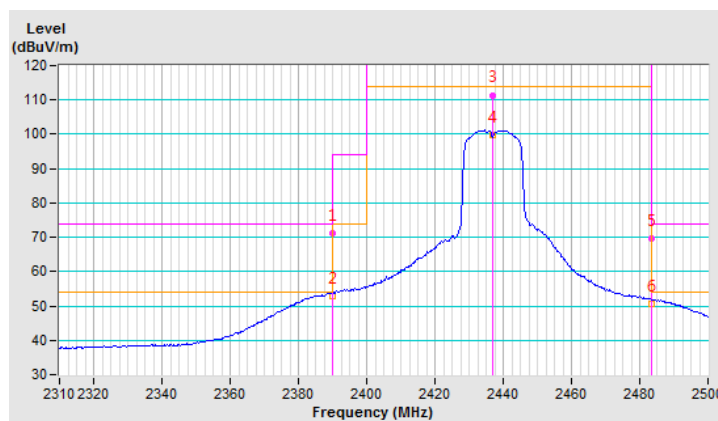

Antenna 1

CHANNEL	TX Channel 11	DETECTOR FUNCTION	Peak (PK)
FREQUENCY RANGE	1GHz ~ 25GHz		Average (AV)

ANTENNA POLARITY & TEST DISTANCE: HORIZONTAL AT 3 M								
NO.	FREQ. (MHz)	EMISSION LEVEL (dBuV/m)	LIMIT (dBuV/m)	MARGIN (dB)	ANTENNA HEIGHT (m)	TABLE ANGLE (Degree)	RAW VALUE (dBuV)	CORRECTION FACTOR (dB/m)
1	*2462.00	107.3 PK			1.00 H	83	111.46	-4.16
2	*2462.00	95.7 AV			1.00 H	83	99.86	-4.16
3	2483.50	73.9 PK	74.0	-0.1	1.00 H	83	77.99	-4.09
4	2483.50	45.6 AV	54.0	-8.4	1.00 H	83	49.69	-4.09

REMARKS:

1. Emission Level(dBuV/m) = Raw Value(dBuV) + Correction Factor(dB/m)
2. Correction Factor(dB/m) = Antenna Factor(dB/m) + Cable Factor(dB) – Pre-Amplifier Factor(dB)
3. The other emission levels were very low against the limit.
4. Margin value = Emission Level – Limit value
5. " * ": Fundamental frequency.

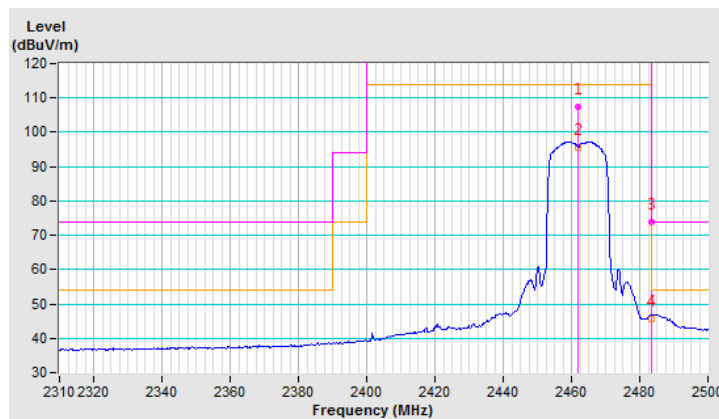

Antenna 1

CHANNEL	TX Channel 11	DETECTOR FUNCTION	Peak (PK)
FREQUENCY RANGE	1GHz ~ 25GHz		Average (AV)

ANTENNA POLARITY & TEST DISTANCE: VERTICAL AT 3 M								
NO.	FREQ. (MHz)	EMISSION LEVEL (dBuV/m)	LIMIT (dBuV/m)	MARGIN (dB)	ANTENNA HEIGHT (m)	TABLE ANGLE (Degree)	RAW VALUE (dBuV)	CORRECTION FACTOR (dB/m)
1	*2462.00	106.9 PK			1.80 V	360	110.91	-4.01
2	*2462.00	96.3 AV			1.80 V	360	100.31	-4.01
3	2483.50	73.9 PK	74.0	-0.1	1.80 V	360	77.85	-3.95
4	2483.50	46.8 AV	54.0	-7.2	1.80 V	360	50.75	-3.95

REMARKS:

1. Emission Level(dBuV/m) = Raw Value(dBuV) + Correction Factor(dB/m)
2. Correction Factor(dB/m) = Antenna Factor(dB/m) + Cable Factor(dB) – Pre-Amplifier Factor(dB)
3. The other emission levels were very low against the limit.
4. Margin value = Emission Level – Limit value
5. " * ": Fundamental frequency.

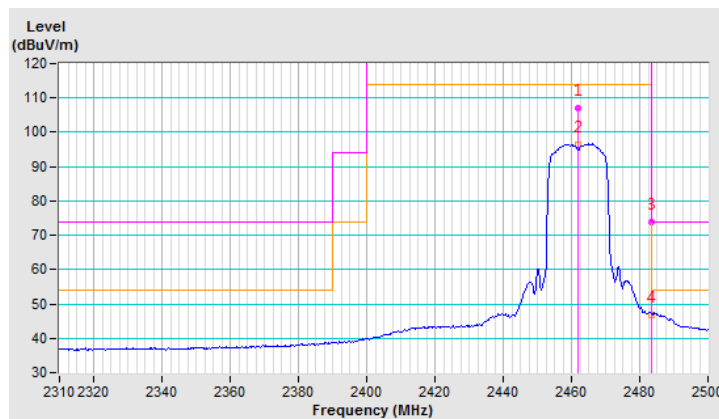

Antenna 1

802.11n (20MHz)

CHANNEL	TX Channel 1	DETECTOR FUNCTION	Peak (PK)
FREQUENCY RANGE	1GHz ~ 25GHz		Average (AV)

ANTENNA POLARITY & TEST DISTANCE: HORIZONTAL AT 3 M

NO.	FREQ. (MHz)	EMISSION LEVEL (dBuV/m)	LIMIT (dBuV/m)	MARGIN (dB)	ANTENNA HEIGHT (m)	TABLE ANGLE (Degree)	RAW VALUE (dBuV)	CORRECTION FACTOR (dB/m)
1	2390.00	69.6 PK	74.0	-4.4	1.01 H	84	73.98	-4.38
2	2390.00	42.7 AV	54.0	-11.3	1.01 H	84	47.08	-4.38
3	*2412.00	104.6 PK			1.01 H	84	108.91	-4.31
4	*2412.00	93.1 AV			1.01 H	84	97.41	-4.31

REMARKS:

1. Emission Level(dBuV/m) = Raw Value(dBuV) + Correction Factor(dB/m)
2. Correction Factor(dB/m) = Antenna Factor(dB/m) + Cable Factor(dB) – Pre-Amplifier Factor(dB)
3. The other emission levels were very low against the limit.
4. Margin value = Emission Level – Limit value
5. " * ": Fundamental frequency.

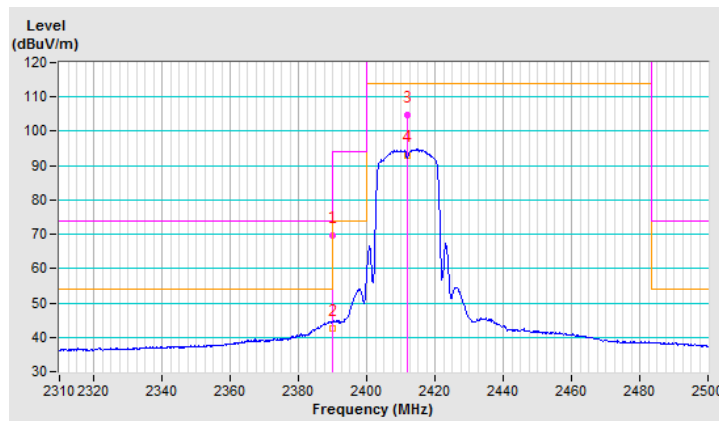

Antenna 1

CHANNEL	TX Channel 1	DETECTOR FUNCTION	Peak (PK)
FREQUENCY RANGE	1GHz ~ 25GHz		Average (AV)

ANTENNA POLARITY & TEST DISTANCE: VERTICAL AT 3 M								
NO.	FREQ. (MHz)	EMISSION LEVEL (dBuV/m)	LIMIT (dBuV/m)	MARGIN (dB)	ANTENNA HEIGHT (m)	TABLE ANGLE (Degree)	RAW VALUE (dBuV)	CORRECTION FACTOR (dB/m)
1	2390.00	73.9 PK	74.0	-0.1	1.79 V	360	78.13	-4.23
2	2390.00	48.8 AV	54.0	-5.2	1.79 V	360	53.03	-4.23
3	*2412.00	107.9 PK			1.79 V	360	112.06	-4.16
4	*2412.00	96.1 AV			1.79 V	360	100.26	-4.16

REMARKS:

1. Emission Level(dBuV/m) = Raw Value(dBuV) + Correction Factor(dB/m)
2. Correction Factor(dB/m) = Antenna Factor(dB/m) + Cable Factor(dB) – Pre-Amplifier Factor(dB)
3. The other emission levels were very low against the limit.
4. Margin value = Emission Level – Limit value
5. " * ": Fundamental frequency.

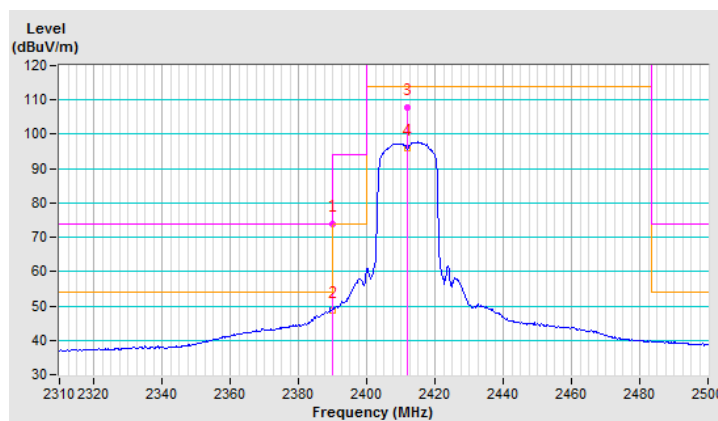

Antenna 1

CHANNEL	TX Channel 6	DETECTOR FUNCTION	Peak (PK)
FREQUENCY RANGE	1GHz ~ 25GHz		Average (AV)

ANTENNA POLARITY & TEST DISTANCE: HORIZONTAL AT 3 M								
NO.	FREQ. (MHz)	EMISSION LEVEL (dBuV/m)	LIMIT (dBuV/m)	MARGIN (dB)	ANTENNA HEIGHT (m)	TABLE ANGLE (Degree)	RAW VALUE (dBuV)	CORRECTION FACTOR (dB/m)
1	2390.00	69.3 PK	74.0	-4.7	1.00 H	84	73.53	-4.23
2	2390.00	50.8 AV	54.0	-3.2	1.00 H	84	55.03	-4.23
3	*2437.00	109.6 PK			1.00 H	84	113.69	-4.09
4	*2437.00	99.5 AV			1.00 H	84	103.59	-4.09
5	2483.50	67.6 PK	74.0	-6.4	1.00 H	84	71.55	-3.95
6	2483.50	48.2 AV	54.0	-5.8	1.00 H	84	52.15	-3.95

REMARKS:

1. Emission Level(dBuV/m) = Raw Value(dBuV) + Correction Factor(dB/m)
2. Correction Factor(dB/m) = Antenna Factor(dB/m) + Cable Factor(dB) – Pre-Amplifier Factor(dB)
3. The other emission levels were very low against the limit.
4. Margin value = Emission Level – Limit value
5. " * ": Fundamental frequency.

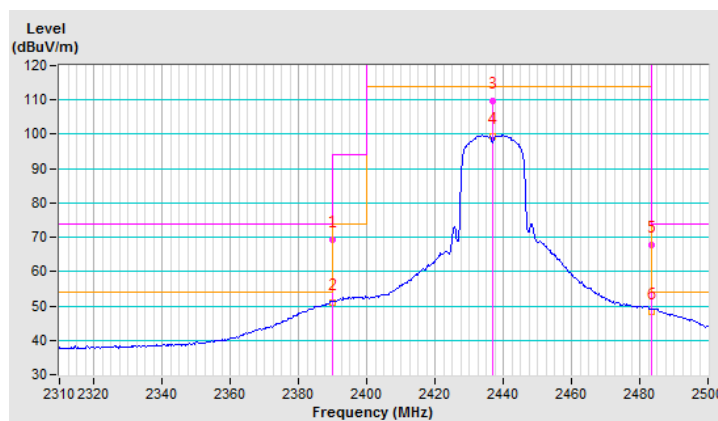

Antenna 1

CHANNEL	TX Channel 6	DETECTOR FUNCTION	Peak (PK)
FREQUENCY RANGE	1GHz ~ 25GHz		Average (AV)

ANTENNA POLARITY & TEST DISTANCE: VERTICAL AT 3 M								
NO.	FREQ. (MHz)	EMISSION LEVEL (dBuV/m)	LIMIT (dBuV/m)	MARGIN (dB)	ANTENNA HEIGHT (m)	TABLE ANGLE (Degree)	RAW VALUE (dBuV)	CORRECTION FACTOR (dB/m)
1	2390.00	70.8 PK	74.0	-3.2	2.06 V	10	75.03	-4.23
2	2390.00	53.5 AV	54.0	-0.5	2.06 V	10	57.73	-4.23
3	*2437.00	110.9 PK			2.06 V	10	114.99	-4.09
4	*2437.00	100.8 AV			2.06 V	10	104.89	-4.09
5	2483.50	70.0 PK	74.0	-4.0	2.06 V	10	73.95	-3.95
6	2483.50	50.7 AV	54.0	-3.3	2.06 V	10	54.65	-3.95

REMARKS:

1. Emission Level(dBuV/m) = Raw Value(dBuV) + Correction Factor(dB/m)
2. Correction Factor(dB/m) = Antenna Factor(dB/m) + Cable Factor(dB) – Pre-Amplifier Factor(dB)
3. The other emission levels were very low against the limit.
4. Margin value = Emission Level – Limit value
5. " * ": Fundamental frequency.

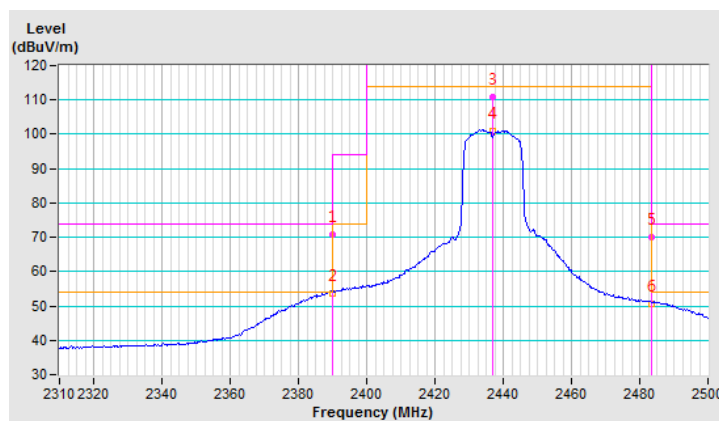

Antenna 1

CHANNEL	TX Channel 11	DETECTOR FUNCTION	Peak (PK)
FREQUENCY RANGE	1GHz ~ 25GHz		Average (AV)

ANTENNA POLARITY & TEST DISTANCE: HORIZONTAL AT 3 M								
NO.	FREQ. (MHz)	EMISSION LEVEL (dBuV/m)	LIMIT (dBuV/m)	MARGIN (dB)	ANTENNA HEIGHT (m)	TABLE ANGLE (Degree)	RAW VALUE (dBuV)	CORRECTION FACTOR (dB/m)
1	*2462.00	105.7 PK			1.00 H	80	109.86	-4.16
2	*2462.00	93.9 AV			1.00 H	80	98.06	-4.16
3	2483.50	72.1 PK	74.0	-1.9	1.00 H	80	76.19	-4.09
4	2483.50	44.6 AV	54.0	-9.4	1.00 H	80	48.69	-4.09

REMARKS:

1. Emission Level(dBuV/m) = Raw Value(dBuV) + Correction Factor(dB/m)
2. Correction Factor(dB/m) = Antenna Factor(dB/m) + Cable Factor(dB) – Pre-Amplifier Factor(dB)
3. The other emission levels were very low against the limit.
4. Margin value = Emission Level – Limit value
5. " * ": Fundamental frequency.

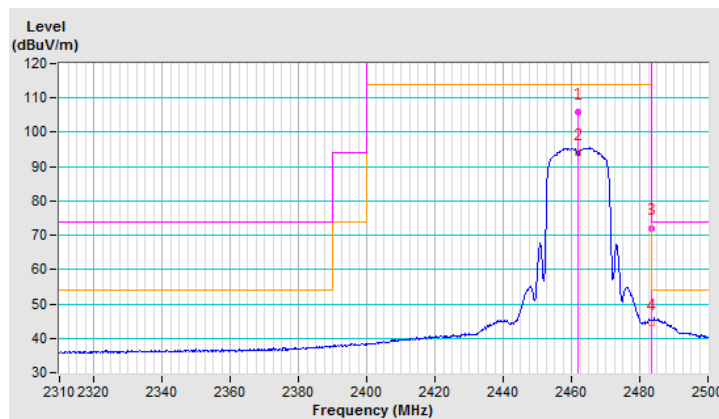

Antenna 1

CHANNEL	TX Channel 11	DETECTOR FUNCTION	Peak (PK)
FREQUENCY RANGE	1GHz ~ 25GHz		Average (AV)

ANTENNA POLARITY & TEST DISTANCE: VERTICAL AT 3 M								
NO.	FREQ. (MHz)	EMISSION LEVEL (dBuV/m)	LIMIT (dBuV/m)	MARGIN (dB)	ANTENNA HEIGHT (m)	TABLE ANGLE (Degree)	RAW VALUE (dBuV)	CORRECTION FACTOR (dB/m)
1	*2462.00	107.7 PK			2.21 V	360	111.71	-4.01
2	*2462.00	96.7 AV			2.21 V	360	100.71	-4.01
3	2483.50	73.9 PK	74.0	-0.1	2.21 V	360	77.85	-3.95
4	2483.50	46.6 AV	54.0	-7.4	2.21 V	360	50.55	-3.95

REMARKS:

1. Emission Level(dBuV/m) = Raw Value(dBuV) + Correction Factor(dB/m)
2. Correction Factor(dB/m) = Antenna Factor(dB/m) + Cable Factor(dB) – Pre-Amplifier Factor(dB)
3. The other emission levels were very low against the limit.
4. Margin value = Emission Level – Limit value
5. " * ": Fundamental frequency.

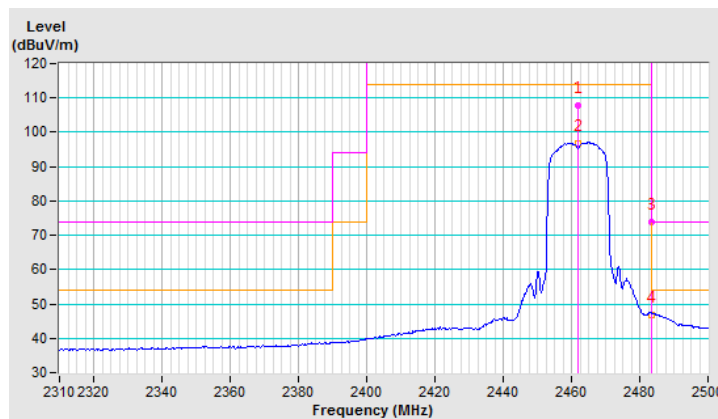

Antenna 1

802.11n (40MHz)

CHANNEL	TX Channel 3	DETECTOR FUNCTION	Peak (PK)
FREQUENCY RANGE	1GHz ~ 25GHz		Average (AV)

ANTENNA POLARITY & TEST DISTANCE: HORIZONTAL AT 3 M

NO.	FREQ. (MHz)	EMISSION LEVEL (dBuV/m)	LIMIT (dBuV/m)	MARGIN (dB)	ANTENNA HEIGHT (m)	TABLE ANGLE (Degree)	RAW VALUE (dBuV)	CORRECTION FACTOR (dB/m)
1	2390.00	71.2 PK	74.0	-2.8	1.00 H	82	75.58	-4.38
2	2390.00	50.1 AV	54.0	-3.9	1.00 H	82	54.48	-4.38
3	*2422.00	99.5 PK			1.00 H	82	103.77	-4.27
4	*2422.00	90.4 AV			1.00 H	82	94.67	-4.27

REMARKS:

1. Emission Level(dBuV/m) = Raw Value(dBuV) + Correction Factor(dB/m)
2. Correction Factor(dB/m) = Antenna Factor(dB/m) + Cable Factor(dB) – Pre-Amplifier Factor(dB)
3. The other emission levels were very low against the limit.
4. Margin value = Emission Level – Limit value
5. " * ": Fundamental frequency.

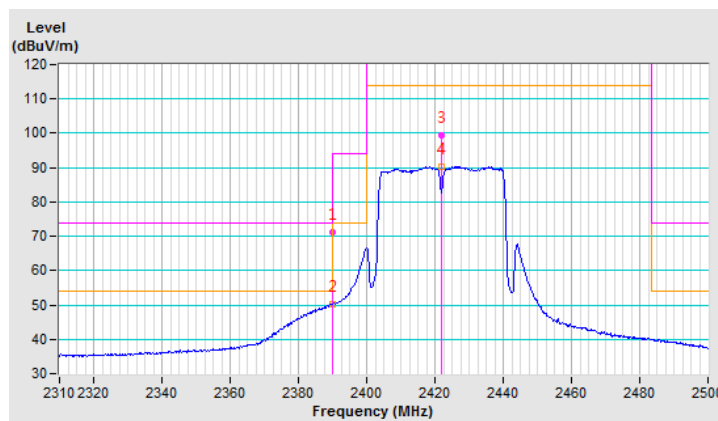

Antenna 1

CHANNEL	TX Channel 3	DETECTOR FUNCTION	Peak (PK)
FREQUENCY RANGE	1GHz ~ 25GHz		Average (AV)

ANTENNA POLARITY & TEST DISTANCE: VERTICAL AT 3 M								
NO.	FREQ. (MHz)	EMISSION LEVEL (dBuV/m)	LIMIT (dBuV/m)	MARGIN (dB)	ANTENNA HEIGHT (m)	TABLE ANGLE (Degree)	RAW VALUE (dBuV)	CORRECTION FACTOR (dB/m)
1	2390.00	73.9 PK	74.0	-0.1	1.81 V	360	78.13	-4.23
2	2390.00	51.6 AV	54.0	-2.4	1.81 V	360	55.83	-4.23
3	*2422.00	101.5 PK			1.81 V	360	105.62	-4.12
4	*2422.00	89.8 AV			1.81 V	360	93.92	-4.12

REMARKS:

1. Emission Level(dBuV/m) = Raw Value(dBuV) + Correction Factor(dB/m)
2. Correction Factor(dB/m) = Antenna Factor(dB/m) + Cable Factor(dB) – Pre-Amplifier Factor(dB)
3. The other emission levels were very low against the limit.
4. Margin value = Emission Level – Limit value
5. " * ": Fundamental frequency.

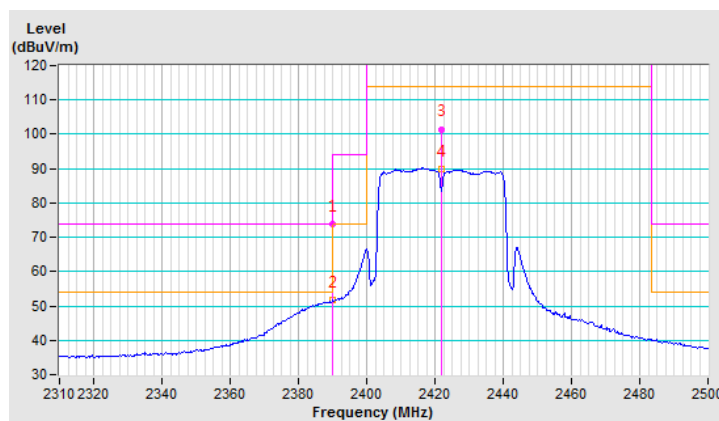

Antenna 1

CHANNEL	TX Channel 6	DETECTOR FUNCTION	Peak (PK)
FREQUENCY RANGE	1GHz ~ 25GHz		Average (AV)

ANTENNA POLARITY & TEST DISTANCE: HORIZONTAL AT 3 M

NO.	FREQ. (MHz)	EMISSION LEVEL (dBuV/m)	LIMIT (dBuV/m)	MARGIN (dB)	ANTENNA HEIGHT (m)	TABLE ANGLE (Degree)	RAW VALUE (dBuV)	CORRECTION FACTOR (dB/m)
1	2390.00	73.9 PK	74.0	-0.1	1.00 H	79	78.28	-4.38
2	2390.00	53.8 AV	54.0	-0.2	1.00 H	79	58.18	-4.38
3	*2437.00	103.5 PK			1.00 H	79	107.74	-4.24
4	*2437.00	93.6 AV			1.00 H	79	97.84	-4.24
5	2483.50	72.9 PK	74.0	-1.1	1.00 H	79	76.99	-4.09
6	2483.50	51.3 AV	54.0	-2.7	1.00 H	79	55.39	-4.09

REMARKS:

1. Emission Level(dBuV/m) = Raw Value(dBuV) + Correction Factor(dB/m)
2. Correction Factor(dB/m) = Antenna Factor(dB/m) + Cable Factor(dB) – Pre-Amplifier Factor(dB)
3. The other emission levels were very low against the limit.
4. Margin value = Emission Level – Limit value
5. " * ": Fundamental frequency.

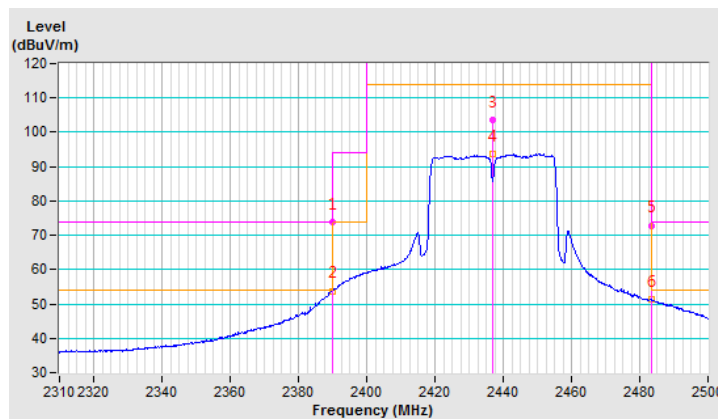

Antenna 1

CHANNEL	TX Channel 6	DETECTOR FUNCTION	Peak (PK)
FREQUENCY RANGE	1GHz ~ 25GHz		Average (AV)

ANTENNA POLARITY & TEST DISTANCE: VERTICAL AT 3 M								
NO.	FREQ. (MHz)	EMISSION LEVEL (dBuV/m)	LIMIT (dBuV/m)	MARGIN (dB)	ANTENNA HEIGHT (m)	TABLE ANGLE (Degree)	RAW VALUE (dBuV)	CORRECTION FACTOR (dB/m)
1	2390.00	73.1 PK	74.0	-0.9	2.33 V	360	77.33	-4.23
2	2390.00	53.4 AV	54.0	-0.6	2.33 V	360	57.63	-4.23
3	*2437.00	103.4 PK			2.33 V	360	107.49	-4.09
4	*2437.00	92.2 AV			2.33 V	360	96.29	-4.09
5	2483.50	71.6 PK	74.0	-2.4	2.33 V	360	75.55	-3.95
6	2483.50	49.1 AV	54.0	-4.9	2.33 V	360	53.05	-3.95

REMARKS:

1. Emission Level(dBuV/m) = Raw Value(dBuV) + Correction Factor(dB/m)
2. Correction Factor(dB/m) = Antenna Factor(dB/m) + Cable Factor(dB) – Pre-Amplifier Factor(dB)
3. The other emission levels were very low against the limit.
4. Margin value = Emission Level – Limit value
5. " * ": Fundamental frequency.

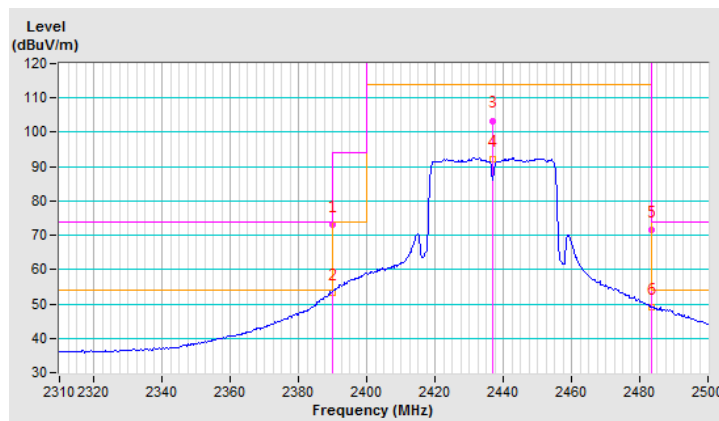

Antenna 1

CHANNEL	TX Channel 9	DETECTOR FUNCTION	Peak (PK)
FREQUENCY RANGE	1GHz ~ 25GHz		Average (AV)

ANTENNA POLARITY & TEST DISTANCE: HORIZONTAL AT 3 M								
NO.	FREQ. (MHz)	EMISSION LEVEL (dBuV/m)	LIMIT (dBuV/m)	MARGIN (dB)	ANTENNA HEIGHT (m)	TABLE ANGLE (Degree)	RAW VALUE (dBuV)	CORRECTION FACTOR (dB/m)
1	*2452.00	100.7 PK			1.00 H	80	104.89	-4.19
2	*2452.00	90.2 AV			1.00 H	80	94.39	-4.19
3	2483.50	73.5 PK	74.0	-0.5	1.00 H	80	77.59	-4.09
4	2483.50	49.0 AV	54.0	-5.0	1.00 H	80	53.09	-4.09

REMARKS:

1. Emission Level(dBuV/m) = Raw Value(dBuV) + Correction Factor(dB/m)
2. Correction Factor(dB/m) = Antenna Factor(dB/m) + Cable Factor(dB) – Pre-Amplifier Factor(dB)
3. The other emission levels were very low against the limit.
4. Margin value = Emission Level – Limit value
5. " * ": Fundamental frequency.

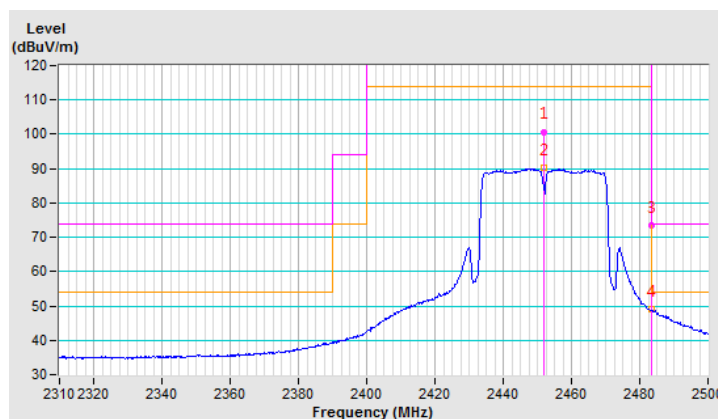

Antenna 1

CHANNEL	TX Channel 9	DETECTOR FUNCTION	Peak (PK)
FREQUENCY RANGE	1GHz ~ 25GHz		Average (AV)

ANTENNA POLARITY & TEST DISTANCE: VERTICAL AT 3 M								
NO.	FREQ. (MHz)	EMISSION LEVEL (dBuV/m)	LIMIT (dBuV/m)	MARGIN (dB)	ANTENNA HEIGHT (m)	TABLE ANGLE (Degree)	RAW VALUE (dBuV)	CORRECTION FACTOR (dB/m)
1	*2452.00	101.4 PK			2.05 V	360	105.45	-4.05
2	*2452.00	90.2 AV			2.05 V	360	94.25	-4.05
3	2483.50	73.9 PK	74.0	-0.1	2.05 V	360	77.85	-3.95
4	2483.50	50.1 AV	54.0	-3.9	2.05 V	360	54.05	-3.95

REMARKS:

1. Emission Level(dBuV/m) = Raw Value(dBuV) + Correction Factor(dB/m)
2. Correction Factor(dB/m) = Antenna Factor(dB/m) + Cable Factor(dB) – Pre-Amplifier Factor(dB)
3. The other emission levels were very low against the limit.
4. Margin value = Emission Level – Limit value
5. " * ": Fundamental frequency.

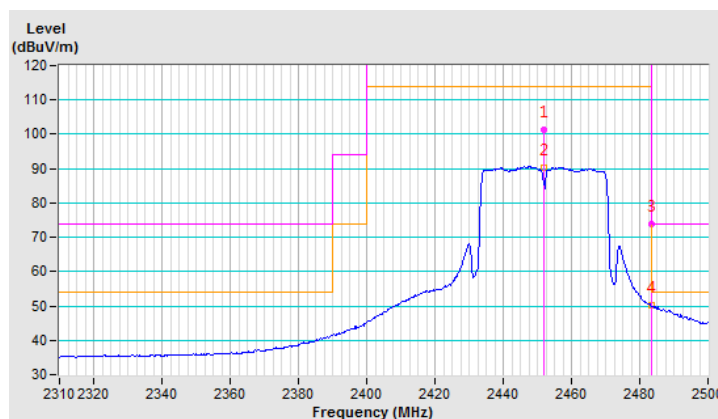

Antenna 2

802.11b

CHANNEL	TX Channel 1	DETECTOR FUNCTION	Peak (PK)
FREQUENCY RANGE	1GHz ~ 25GHz		Average (AV)

ANTENNA POLARITY & TEST DISTANCE: HORIZONTAL AT 3 M								
NO.	FREQ. (MHz)	EMISSION LEVEL (dBuV/m)	LIMIT (dBuV/m)	MARGIN (dB)	ANTENNA HEIGHT (m)	TABLE ANGLE (Degree)	RAW VALUE (dBuV)	CORRECTION FACTOR (dB/m)
1	2390.00	57.4 PK	74.0	-16.6	2.54 H	328	61.63	-4.23
2	2390.00	51.9 AV	54.0	-2.1	2.54 H	328	56.13	-4.23
3	*2412.00	107.2 PK			2.54 H	328	111.36	-4.16
4	*2412.00	104.9 AV			2.54 H	328	109.06	-4.16

REMARKS:

1. Emission Level(dBuV/m) = Raw Value(dBuV) + Correction Factor(dB/m)
2. Correction Factor(dB/m) = Antenna Factor(dB/m) + Cable Factor(dB) – Pre-Amplifier Factor(dB)
3. The other emission levels were very low against the limit.
4. Margin value = Emission Level – Limit value
5. " * ": Fundamental frequency.

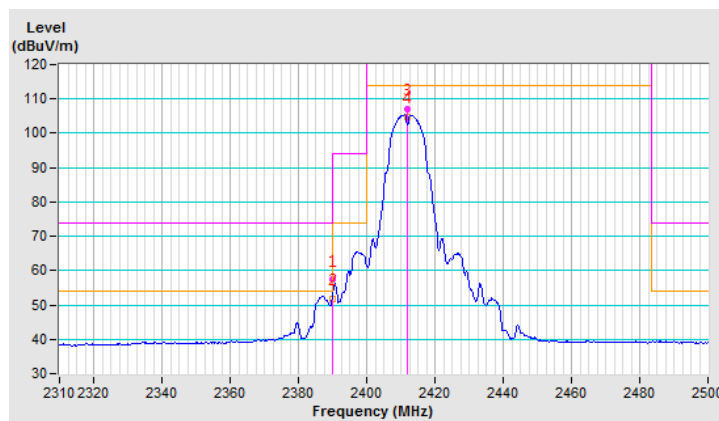

Antenna 2

CHANNEL	TX Channel 1	DETECTOR FUNCTION	Peak (PK)
FREQUENCY RANGE	1GHz ~ 25GHz		Average (AV)

ANTENNA POLARITY & TEST DISTANCE: VERTICAL AT 3 M								
NO.	FREQ. (MHz)	EMISSION LEVEL (dBuV/m)	LIMIT (dBuV/m)	MARGIN (dB)	ANTENNA HEIGHT (m)	TABLE ANGLE (Degree)	RAW VALUE (dBuV)	CORRECTION FACTOR (dB/m)
1	2390.00	52.5 PK	74.0	-21.5	1.11 V	297	56.73	-4.23
2	2390.00	45.3 AV	54.0	-8.7	1.11 V	297	49.53	-4.23
3	*2412.00	102.0 PK			1.11 V	297	106.16	-4.16
4	*2412.00	99.7 AV			1.11 V	297	103.86	-4.16

REMARKS:

1. Emission Level(dBuV/m) = Raw Value(dBuV) + Correction Factor(dB/m)
2. Correction Factor(dB/m) = Antenna Factor(dB/m) + Cable Factor(dB) – Pre-Amplifier Factor(dB)
3. The other emission levels were very low against the limit.
4. Margin value = Emission Level – Limit value
5. " * ": Fundamental frequency.

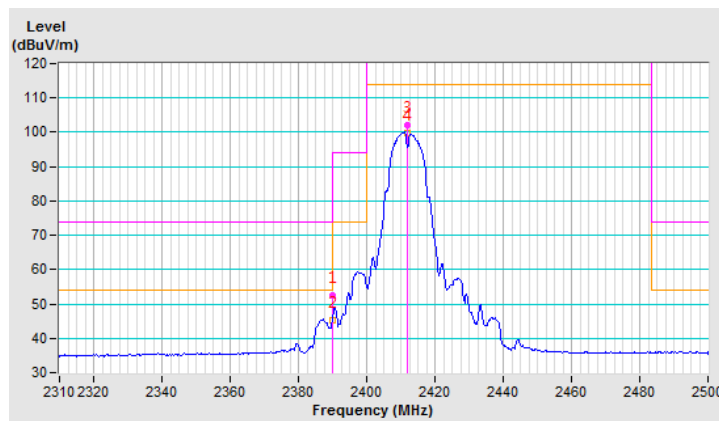

Antenna 2

CHANNEL	TX Channel 6	DETECTOR FUNCTION	Peak (PK)
FREQUENCY RANGE	1GHz ~ 25GHz		Average (AV)

ANTENNA POLARITY & TEST DISTANCE: HORIZONTAL AT 3 M								
NO.	FREQ. (MHz)	EMISSION LEVEL (dBuV/m)	LIMIT (dBuV/m)	MARGIN (dB)	ANTENNA HEIGHT (m)	TABLE ANGLE (Degree)	RAW VALUE (dBuV)	CORRECTION FACTOR (dB/m)
1	2390.00	52.1 PK	74.0	-21.9	2.58 H	321	56.33	-4.23
2	2390.00	41.0 AV	54.0	-13.0	2.58 H	321	45.23	-4.23
3	*2437.00	110.3 PK			2.58 H	321	114.39	-4.09
4	*2437.00	107.9 AV			2.58 H	321	111.99	-4.09
5	2483.50	50.9 PK	74.0	-23.1	2.58 H	321	54.85	-3.95
6	2483.50	39.5 AV	54.0	-14.5	2.58 H	321	43.45	-3.95

REMARKS:

1. Emission Level(dBuV/m) = Raw Value(dBuV) + Correction Factor(dB/m)
2. Correction Factor(dB/m) = Antenna Factor(dB/m) + Cable Factor(dB) – Pre-Amplifier Factor(dB)
3. The other emission levels were very low against the limit.
4. Margin value = Emission Level – Limit value
5. " * ": Fundamental frequency.

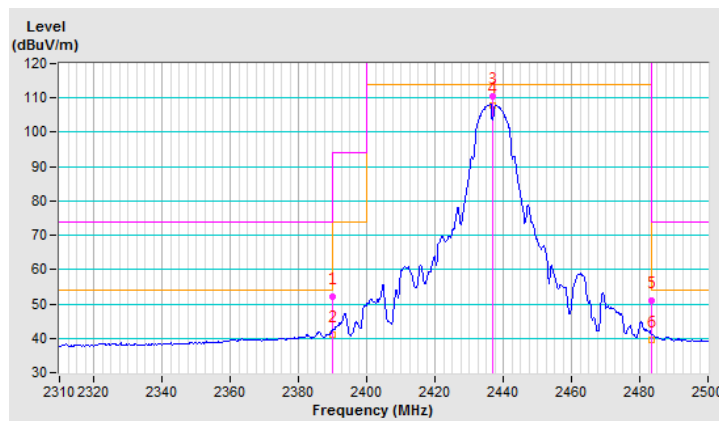

Antenna 2

CHANNEL	TX Channel 6	DETECTOR FUNCTION	Peak (PK)
FREQUENCY RANGE	1GHz ~ 25GHz		Average (AV)

ANTENNA POLARITY & TEST DISTANCE: VERTICAL AT 3 M								
NO.	FREQ. (MHz)	EMISSION LEVEL (dBuV/m)	LIMIT (dBuV/m)	MARGIN (dB)	ANTENNA HEIGHT (m)	TABLE ANGLE (Degree)	RAW VALUE (dBuV)	CORRECTION FACTOR (dB/m)
1	2390.00	48.8 PK	74.0	-25.2	3.81 V	170	53.03	-4.23
2	2390.00	37.8 AV	54.0	-16.2	3.81 V	170	42.03	-4.23
3	*2437.00	106.4 PK			3.81 V	170	110.49	-4.09
4	*2437.00	104.3 AV			3.81 V	170	108.39	-4.09
5	2483.50	48.9 PK	74.0	-25.1	3.81 V	170	52.85	-3.95
6	2483.50	37.2 AV	54.0	-16.8	3.81 V	170	41.15	-3.95

REMARKS:

1. Emission Level(dBuV/m) = Raw Value(dBuV) + Correction Factor(dB/m)
2. Correction Factor(dB/m) = Antenna Factor(dB/m) + Cable Factor(dB) – Pre-Amplifier Factor(dB)
3. The other emission levels were very low against the limit.
4. Margin value = Emission Level – Limit value
5. " * ": Fundamental frequency.

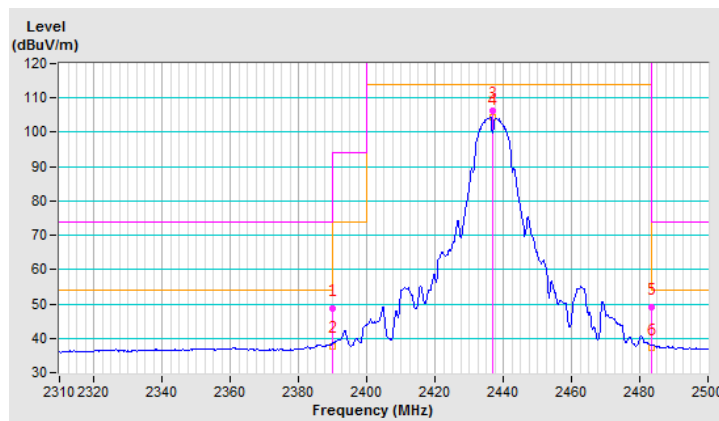

Antenna 2

CHANNEL	TX Channel 11	DETECTOR FUNCTION	Peak (PK)
FREQUENCY RANGE	1GHz ~ 25GHz		Average (AV)

ANTENNA POLARITY & TEST DISTANCE: HORIZONTAL AT 3 M

NO.	FREQ. (MHz)	EMISSION LEVEL (dBuV/m)	LIMIT (dBuV/m)	MARGIN (dB)	ANTENNA HEIGHT (m)	TABLE ANGLE (Degree)	RAW VALUE (dBuV)	CORRECTION FACTOR (dB/m)
1	*2462.00	106.9 PK			2.58 H	321	110.91	-4.01
2	*2462.00	104.5 AV			2.58 H	321	108.51	-4.01
3	2483.50	58.8 PK	74.0	-15.2	2.58 H	321	62.75	-3.95
4	2483.50	53.6 AV	54.0	-0.4	2.58 H	321	57.55	-3.95

REMARKS:

1. Emission Level(dBuV/m) = Raw Value(dBuV) + Correction Factor(dB/m)
2. Correction Factor(dB/m) = Antenna Factor(dB/m) + Cable Factor(dB) – Pre-Amplifier Factor(dB)
3. The other emission levels were very low against the limit.
4. Margin value = Emission Level – Limit value
5. " * ": Fundamental frequency.

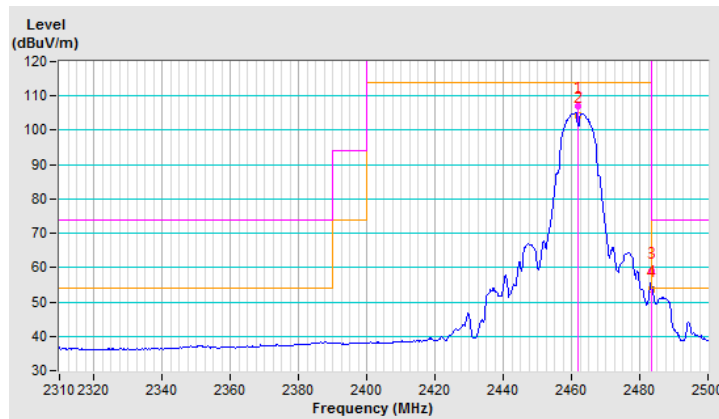

Antenna 2

CHANNEL	TX Channel 11	DETECTOR FUNCTION	Peak (PK)
FREQUENCY RANGE	1GHz ~ 25GHz		Average (AV)

ANTENNA POLARITY & TEST DISTANCE: VERTICAL AT 3 M								
NO.	FREQ. (MHz)	EMISSION LEVEL (dBuV/m)	LIMIT (dBuV/m)	MARGIN (dB)	ANTENNA HEIGHT (m)	TABLE ANGLE (Degree)	RAW VALUE (dBuV)	CORRECTION FACTOR (dB/m)
1	*2462.00	104.4 PK			3.69 V	358	108.41	-4.01
2	*2462.00	102.3 AV			3.69 V	358	106.31	-4.01
3	2483.50	55.4 PK	74.0	-18.6	3.69 V	358	59.35	-3.95
4	2483.50	49.9 AV	54.0	-4.1	3.69 V	358	53.85	-3.95

REMARKS:

1. Emission Level(dBuV/m) = Raw Value(dBuV) + Correction Factor(dB/m)
2. Correction Factor(dB/m) = Antenna Factor(dB/m) + Cable Factor(dB) – Pre-Amplifier Factor(dB)
3. The other emission levels were very low against the limit.
4. Margin value = Emission Level – Limit value
5. " * ": Fundamental frequency.

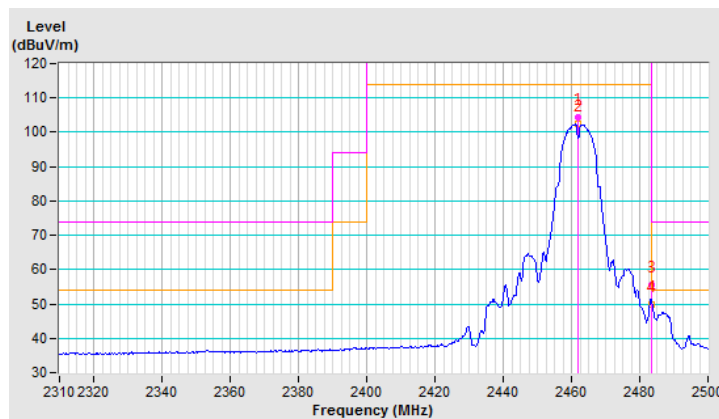

Antenna 2

802.11g

CHANNEL	TX Channel 1	DETECTOR FUNCTION	Peak (PK)
FREQUENCY RANGE	1GHz ~ 25GHz		Average (AV)

ANTENNA POLARITY & TEST DISTANCE: HORIZONTAL AT 3 M								
NO.	FREQ. (MHz)	EMISSION LEVEL (dBuV/m)	LIMIT (dBuV/m)	MARGIN (dB)	ANTENNA HEIGHT (m)	TABLE ANGLE (Degree)	RAW VALUE (dBuV)	CORRECTION FACTOR (dB/m)
1	2390.00	73.9 PK	74.0	-0.1	2.86 H	293	78.13	-4.23
2	2390.00	50.7 AV	54.0	-3.3	2.86 H	293	54.93	-4.23
3	*2412.00	110.1 PK			2.86 H	293	114.26	-4.16
4	*2412.00	99.6 AV			2.86 H	293	103.76	-4.16

REMARKS:

1. Emission Level(dBuV/m) = Raw Value(dBuV) + Correction Factor(dB/m)
2. Correction Factor(dB/m) = Antenna Factor(dB/m) + Cable Factor(dB) – Pre-Amplifier Factor(dB)
3. The other emission levels were very low against the limit.
4. Margin value = Emission Level – Limit value
5. " * ": Fundamental frequency.

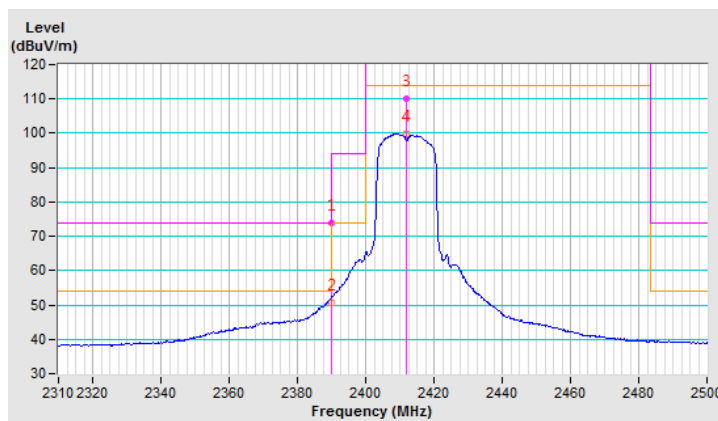

Antenna 2

CHANNEL	TX Channel 1	DETECTOR FUNCTION	Peak (PK)
FREQUENCY RANGE	1GHz ~ 25GHz		Average (AV)

ANTENNA POLARITY & TEST DISTANCE: VERTICAL AT 3 M								
NO.	FREQ. (MHz)	EMISSION LEVEL (dBuV/m)	LIMIT (dBuV/m)	MARGIN (dB)	ANTENNA HEIGHT (m)	TABLE ANGLE (Degree)	RAW VALUE (dBuV)	CORRECTION FACTOR (dB/m)
1	2390.00	69.2 PK	74.0	-4.8	3.69 V	358	73.43	-4.23
2	2390.00	46.9 AV	54.0	-7.1	3.69 V	358	51.13	-4.23
3	*2412.00	106.2 PK			3.69 V	358	110.36	-4.16
4	*2412.00	95.7 AV			3.69 V	358	99.86	-4.16

REMARKS:

1. Emission Level(dBuV/m) = Raw Value(dBuV) + Correction Factor(dB/m)
2. Correction Factor(dB/m) = Antenna Factor(dB/m) + Cable Factor(dB) – Pre-Amplifier Factor(dB)
3. The other emission levels were very low against the limit.
4. Margin value = Emission Level – Limit value
5. " * ": Fundamental frequency.

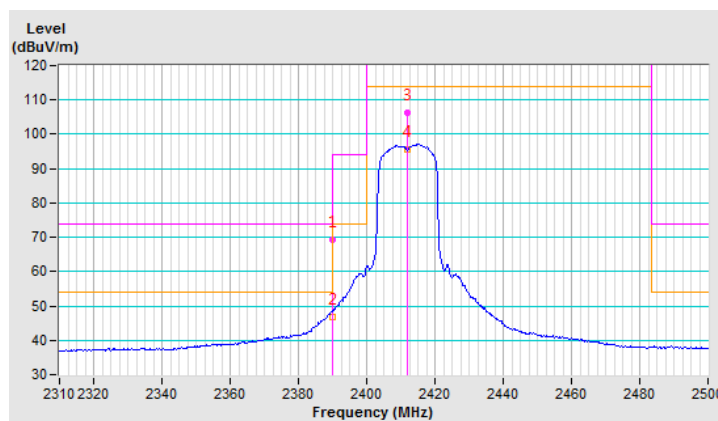

Antenna 2

CHANNEL	TX Channel 6	DETECTOR FUNCTION	Peak (PK)
FREQUENCY RANGE	1GHz ~ 25GHz		Average (AV)

ANTENNA POLARITY & TEST DISTANCE: HORIZONTAL AT 3 M

NO.	FREQ. (MHz)	EMISSION LEVEL (dBuV/m)	LIMIT (dBuV/m)	MARGIN (dB)	ANTENNA HEIGHT (m)	TABLE ANGLE (Degree)	RAW VALUE (dBuV)	CORRECTION FACTOR (dB/m)
1	2390.00	71.8 PK	74.0	-2.2	2.80 H	296	76.03	-4.23
2	2390.00	53.3 AV	54.0	-0.7	2.80 H	296	57.53	-4.23
3	*2437.00	113.7 PK			2.80 H	296	117.79	-4.09
4	*2437.00	103.4 AV			2.80 H	296	107.49	-4.09
5	2483.50	67.9 PK	74.0	-6.1	2.80 H	296	71.85	-3.95
6	2483.50	46.8 AV	54.0	-7.2	2.80 H	296	50.75	-3.95

REMARKS:

1. Emission Level(dBuV/m) = Raw Value(dBuV) + Correction Factor(dB/m)
2. Correction Factor(dB/m) = Antenna Factor(dB/m) + Cable Factor(dB) – Pre-Amplifier Factor(dB)
3. The other emission levels were very low against the limit.
4. Margin value = Emission Level – Limit value
5. " * ": Fundamental frequency.

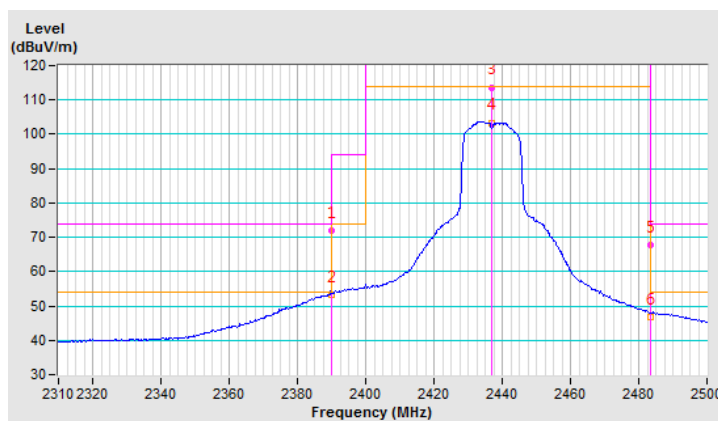

Antenna 2

CHANNEL	TX Channel 6	DETECTOR FUNCTION	Peak (PK)
FREQUENCY RANGE	1GHz ~ 25GHz		Average (AV)

ANTENNA POLARITY & TEST DISTANCE: VERTICAL AT 3 M								
NO.	FREQ. (MHz)	EMISSION LEVEL (dBuV/m)	LIMIT (dBuV/m)	MARGIN (dB)	ANTENNA HEIGHT (m)	TABLE ANGLE (Degree)	RAW VALUE (dBuV)	CORRECTION FACTOR (dB/m)
1	2390.00	70.1 PK	74.0	-3.9	3.77 V	346	74.33	-4.23
2	2390.00	51.3 AV	54.0	-2.7	3.77 V	346	55.53	-4.23
3	*2437.00	109.9 PK			3.77 V	346	113.99	-4.09
4	*2437.00	99.8 AV			3.77 V	346	103.89	-4.09
5	2483.50	61.2 PK	74.0	-12.8	3.77 V	346	65.15	-3.95
6	2483.50	43.3 AV	54.0	-10.7	3.77 V	346	47.25	-3.95

REMARKS:

1. Emission Level(dBuV/m) = Raw Value(dBuV) + Correction Factor(dB/m)
2. Correction Factor(dB/m) = Antenna Factor(dB/m) + Cable Factor(dB) – Pre-Amplifier Factor(dB)
3. The other emission levels were very low against the limit.
4. Margin value = Emission Level – Limit value
5. " * ": Fundamental frequency.

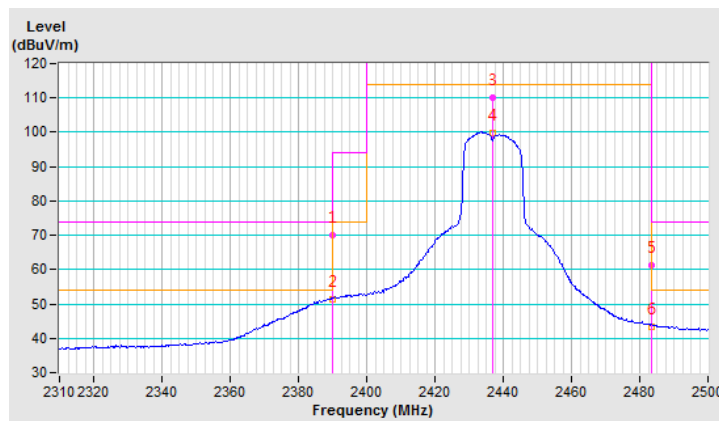

Antenna 2

CHANNEL	TX Channel 11	DETECTOR FUNCTION	Peak (PK)
FREQUENCY RANGE	1GHz ~ 25GHz		Average (AV)

ANTENNA POLARITY & TEST DISTANCE: HORIZONTAL AT 3 M								
NO.	FREQ. (MHz)	EMISSION LEVEL (dBuV/m)	LIMIT (dBuV/m)	MARGIN (dB)	ANTENNA HEIGHT (m)	TABLE ANGLE (Degree)	RAW VALUE (dBuV)	CORRECTION FACTOR (dB/m)
1	*2462.00	109.8 PK			2.80 H	296	113.81	-4.01
2	*2462.00	98.9 AV			2.80 H	296	102.91	-4.01
3	2483.50	73.9 PK	74.0	-0.1	2.80 H	296	77.85	-3.95
4	2483.50	49.3 AV	54.0	-4.7	2.80 H	296	53.25	-3.95

REMARKS:

1. Emission Level(dBuV/m) = Raw Value(dBuV) + Correction Factor(dB/m)
2. Correction Factor(dB/m) = Antenna Factor(dB/m) + Cable Factor(dB) – Pre-Amplifier Factor(dB)
3. The other emission levels were very low against the limit.
4. Margin value = Emission Level – Limit value
5. " * ": Fundamental frequency.

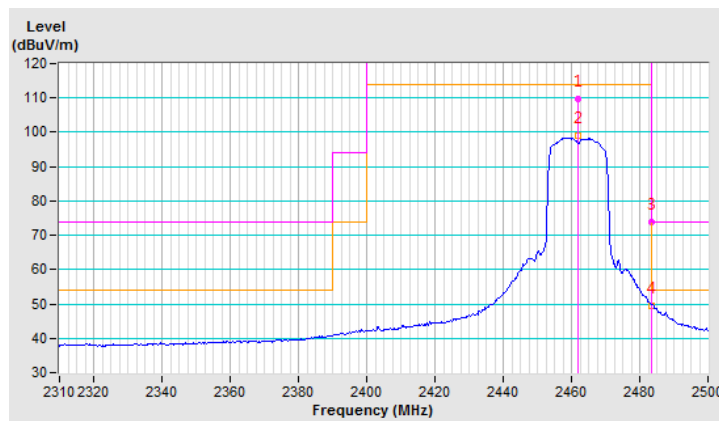

Antenna 2

CHANNEL	TX Channel 11	DETECTOR FUNCTION	Peak (PK)
FREQUENCY RANGE	1GHz ~ 25GHz		Average (AV)

ANTENNA POLARITY & TEST DISTANCE: VERTICAL AT 3 M								
NO.	FREQ. (MHz)	EMISSION LEVEL (dBuV/m)	LIMIT (dBuV/m)	MARGIN (dB)	ANTENNA HEIGHT (m)	TABLE ANGLE (Degree)	RAW VALUE (dBuV)	CORRECTION FACTOR (dB/m)
1	*2462.00	107.4 PK			3.70 V	357	111.41	-4.01
2	*2462.00	96.3 AV			3.70 V	357	100.31	-4.01
3	2483.50	70.9 PK	74.0	-3.1	3.70 V	357	74.85	-3.95
4	2483.50	46.7 AV	54.0	-7.3	3.70 V	357	50.65	-3.95

REMARKS:

1. Emission Level(dBuV/m) = Raw Value(dBuV) + Correction Factor(dB/m)
2. Correction Factor(dB/m) = Antenna Factor(dB/m) + Cable Factor(dB) – Pre-Amplifier Factor(dB)
3. The other emission levels were very low against the limit.
4. Margin value = Emission Level – Limit value
5. " * ": Fundamental frequency.

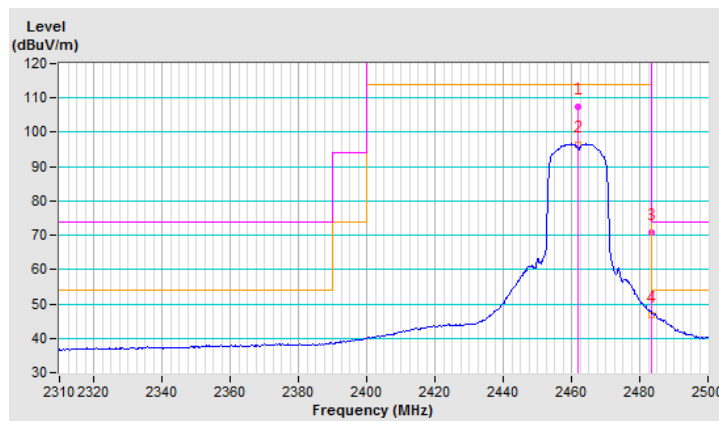

Antenna 2

802.11n (20MHz)

CHANNEL	TX Channel 1	DETECTOR FUNCTION	Peak (PK)
FREQUENCY RANGE	1GHz ~ 25GHz		Average (AV)

ANTENNA POLARITY & TEST DISTANCE: HORIZONTAL AT 3 M								
NO.	FREQ. (MHz)	EMISSION LEVEL (dBuV/m)	LIMIT (dBuV/m)	MARGIN (dB)	ANTENNA HEIGHT (m)	TABLE ANGLE (Degree)	RAW VALUE (dBuV)	CORRECTION FACTOR (dB/m)
1	2390.00	73.5 PK	74.0	-0.5	2.88 H	301	77.73	-4.23
2	2390.00	47.7 AV	54.0	-6.3	2.88 H	301	51.93	-4.23
3	*2412.00	108.2 PK			2.88 H	301	112.36	-4.16
4	*2412.00	97.3 AV			2.88 H	301	101.46	-4.16

REMARKS:

1. Emission Level(dBuV/m) = Raw Value(dBuV) + Correction Factor(dB/m)
2. Correction Factor(dB/m) = Antenna Factor(dB/m) + Cable Factor(dB) – Pre-Amplifier Factor(dB)
3. The other emission levels were very low against the limit.
4. Margin value = Emission Level – Limit value
5. " * ": Fundamental frequency.

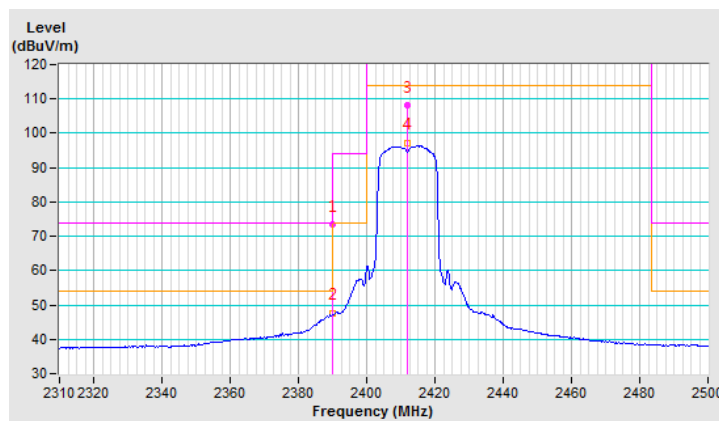

Antenna 2

CHANNEL	TX Channel 1	DETECTOR FUNCTION	Peak (PK)
FREQUENCY RANGE	1GHz ~ 25GHz		Average (AV)

ANTENNA POLARITY & TEST DISTANCE: VERTICAL AT 3 M								
NO.	FREQ. (MHz)	EMISSION LEVEL (dBuV/m)	LIMIT (dBuV/m)	MARGIN (dB)	ANTENNA HEIGHT (m)	TABLE ANGLE (Degree)	RAW VALUE (dBuV)	CORRECTION FACTOR (dB/m)
1	2390.00	70.5 PK	74.0	-3.5	3.70 V	357	74.73	-4.23
2	2390.00	43.4 AV	54.0	-10.6	3.70 V	357	47.63	-4.23
3	*2412.00	104.7 PK			3.70 V	357	108.86	-4.16
4	*2412.00	94.4 AV			3.70 V	357	98.56	-4.16

REMARKS:

1. Emission Level(dBuV/m) = Raw Value(dBuV) + Correction Factor(dB/m)
2. Correction Factor(dB/m) = Antenna Factor(dB/m) + Cable Factor(dB) – Pre-Amplifier Factor(dB)
3. The other emission levels were very low against the limit.
4. Margin value = Emission Level – Limit value
5. " * ": Fundamental frequency.

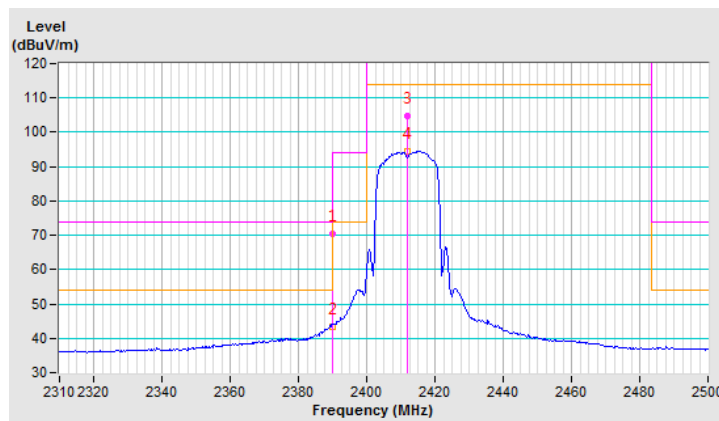

Antenna 2

CHANNEL	TX Channel 6	DETECTOR FUNCTION	Peak (PK)
FREQUENCY RANGE	1GHz ~ 25GHz		Average (AV)

ANTENNA POLARITY & TEST DISTANCE: HORIZONTAL AT 3 M

NO.	FREQ. (MHz)	EMISSION LEVEL (dBuV/m)	LIMIT (dBuV/m)	MARGIN (dB)	ANTENNA HEIGHT (m)	TABLE ANGLE (Degree)	RAW VALUE (dBuV)	CORRECTION FACTOR (dB/m)
1	2390.00	71.3 PK	74.0	-2.7	2.80 H	306	75.53	-4.23
2	2390.00	53.8 AV	54.0	-0.2	2.80 H	306	58.03	-4.23
3	*2437.00	113.0 PK			2.80 H	306	117.09	-4.09
4	*2437.00	102.9 AV			2.80 H	306	106.99	-4.09
5	2483.50	67.2 PK	74.0	-6.8	2.80 H	306	71.15	-3.95
6	2483.50	46.9 AV	54.0	-7.1	2.80 H	306	50.85	-3.95

REMARKS:

1. Emission Level(dBuV/m) = Raw Value(dBuV) + Correction Factor(dB/m)
2. Correction Factor(dB/m) = Antenna Factor(dB/m) + Cable Factor(dB) – Pre-Amplifier Factor(dB)
3. The other emission levels were very low against the limit.
4. Margin value = Emission Level – Limit value
5. " * ": Fundamental frequency.

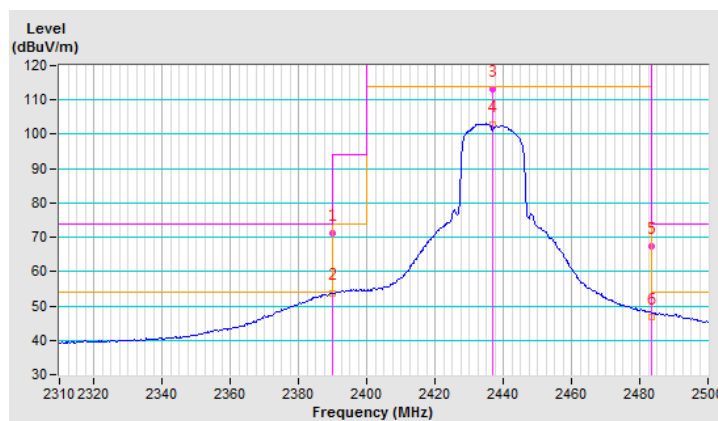

Antenna 2

CHANNEL	TX Channel 6	DETECTOR FUNCTION	Peak (PK)
FREQUENCY RANGE	1GHz ~ 25GHz		Average (AV)

ANTENNA POLARITY & TEST DISTANCE: VERTICAL AT 3 M

NO.	FREQ. (MHz)	EMISSION LEVEL (dBuV/m)	LIMIT (dBuV/m)	MARGIN (dB)	ANTENNA HEIGHT (m)	TABLE ANGLE (Degree)	RAW VALUE (dBuV)	CORRECTION FACTOR (dB/m)
1	2390.00	67.1 PK	74.0	-6.9	3.65 V	357	71.33	-4.23
2	2390.00	48.6 AV	54.0	-5.4	3.65 V	357	52.83	-4.23
3	*2437.00	109.8 PK			3.65 V	357	113.89	-4.09
4	*2437.00	99.5 AV			3.65 V	357	103.59	-4.09
5	2483.50	64.4 PK	74.0	-9.6	3.65 V	357	68.35	-3.95
6	2483.50	45.7 AV	54.0	-8.3	3.65 V	357	49.65	-3.95

REMARKS:

1. Emission Level(dBuV/m) = Raw Value(dBuV) + Correction Factor(dB/m)
2. Correction Factor(dB/m) = Antenna Factor(dB/m) + Cable Factor(dB) – Pre-Amplifier Factor(dB)
3. The other emission levels were very low against the limit.
4. Margin value = Emission Level – Limit value
5. " * ": Fundamental frequency.

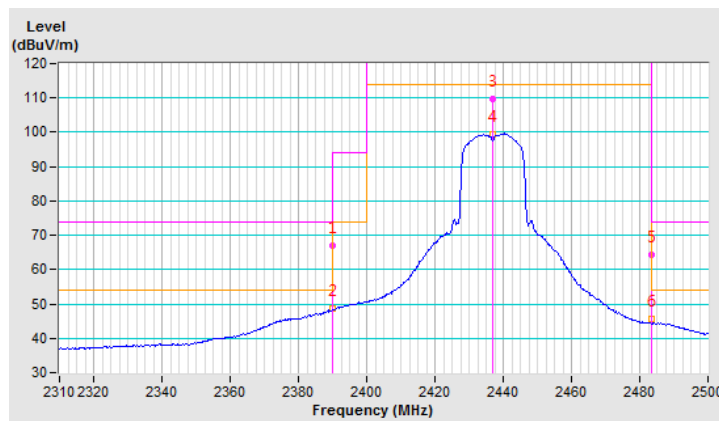

Antenna 2

CHANNEL	TX Channel 11	DETECTOR FUNCTION	Peak (PK)
FREQUENCY RANGE	1GHz ~ 25GHz		Average (AV)

ANTENNA POLARITY & TEST DISTANCE: HORIZONTAL AT 3 M								
NO.	FREQ. (MHz)	EMISSION LEVEL (dBuV/m)	LIMIT (dBuV/m)	MARGIN (dB)	ANTENNA HEIGHT (m)	TABLE ANGLE (Degree)	RAW VALUE (dBuV)	CORRECTION FACTOR (dB/m)
1	*2462.00	108.2 PK			2.73 H	297	112.21	-4.01
2	*2462.00	97.6 AV			2.73 H	297	101.61	-4.01
3	2483.50	73.9 PK	74.0	-0.1	2.73 H	297	77.85	-3.95
4	2483.50	47.9 AV	54.0	-6.1	2.73 H	297	51.85	-3.95

REMARKS:

1. Emission Level(dBuV/m) = Raw Value(dBuV) + Correction Factor(dB/m)
2. Correction Factor(dB/m) = Antenna Factor(dB/m) + Cable Factor(dB) – Pre-Amplifier Factor(dB)
3. The other emission levels were very low against the limit.
4. Margin value = Emission Level – Limit value
5. " * ": Fundamental frequency.

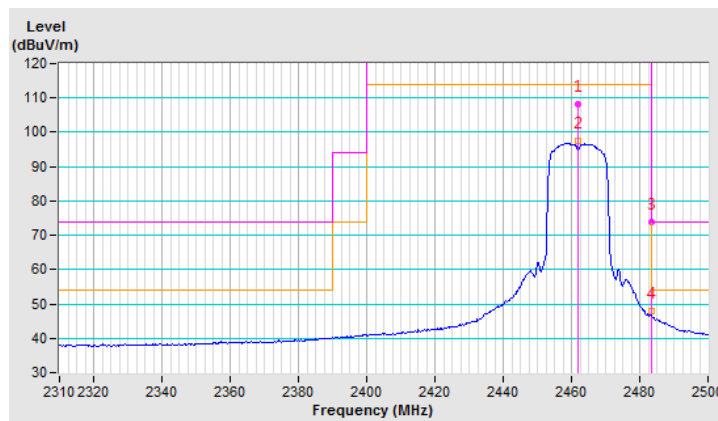

Antenna 2

CHANNEL	TX Channel 11	DETECTOR FUNCTION	Peak (PK)
FREQUENCY RANGE	1GHz ~ 25GHz		Average (AV)

ANTENNA POLARITY & TEST DISTANCE: VERTICAL AT 3 M								
NO.	FREQ. (MHz)	EMISSION LEVEL (dBuV/m)	LIMIT (dBuV/m)	MARGIN (dB)	ANTENNA HEIGHT (m)	TABLE ANGLE (Degree)	RAW VALUE (dBuV)	CORRECTION FACTOR (dB/m)
1	*2462.00	105.2 PK			3.71 V	357	109.21	-4.01
2	*2462.00	94.3 AV			3.71 V	357	98.31	-4.01
3	2483.50	69.5 PK	74.0	-4.5	3.71 V	357	73.45	-3.95
4	2483.50	43.3 AV	54.0	-10.7	3.71 V	357	47.25	-3.95

REMARKS:

1. Emission Level(dBuV/m) = Raw Value(dBuV) + Correction Factor(dB/m)
2. Correction Factor(dB/m) = Antenna Factor(dB/m) + Cable Factor(dB) – Pre-Amplifier Factor(dB)
3. The other emission levels were very low against the limit.
4. Margin value = Emission Level – Limit value
5. " * ": Fundamental frequency.

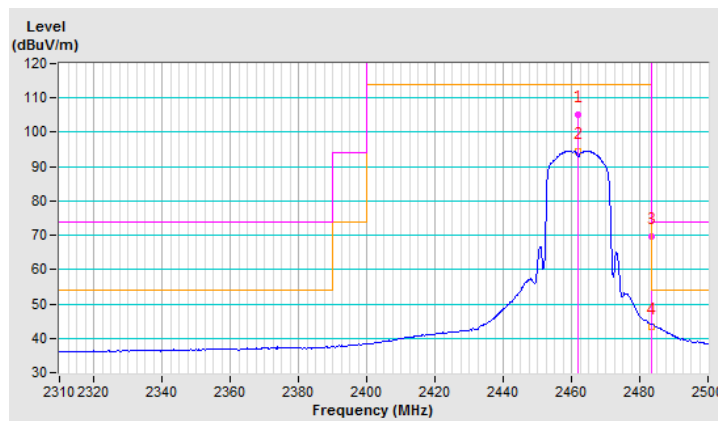

Antenna 2

802.11n (40MHz)

CHANNEL	TX Channel 3	DETECTOR FUNCTION	Peak (PK)
FREQUENCY RANGE	1GHz ~ 25GHz		Average (AV)

ANTENNA POLARITY & TEST DISTANCE: HORIZONTAL AT 3 M								
NO.	FREQ. (MHz)	EMISSION LEVEL (dBuV/m)	LIMIT (dBuV/m)	MARGIN (dB)	ANTENNA HEIGHT (m)	TABLE ANGLE (Degree)	RAW VALUE (dBuV)	CORRECTION FACTOR (dB/m)
1	2390.00	73.5 PK	74.0	-0.5	2.78 H	305	77.73	-4.23
2	2390.00	53.5 AV	54.0	-0.5	2.78 H	305	57.73	-4.23
3	*2422.00	101.9 PK			2.78 H	305	106.02	-4.12
4	*2422.00	92.1 AV			2.78 H	305	96.22	-4.12

REMARKS:

1. Emission Level(dBuV/m) = Raw Value(dBuV) + Correction Factor(dB/m)
2. Correction Factor(dB/m) = Antenna Factor(dB/m) + Cable Factor(dB) – Pre-Amplifier Factor(dB)
3. The other emission levels were very low against the limit.
4. Margin value = Emission Level – Limit value
5. " * ": Fundamental frequency.

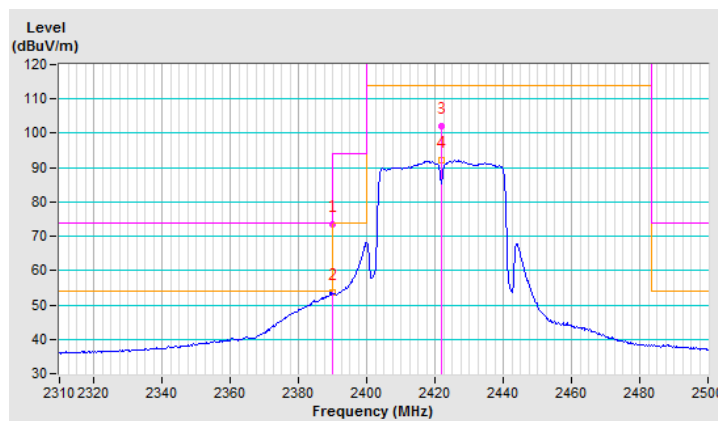

Antenna 2

CHANNEL	TX Channel 3	DETECTOR FUNCTION	Peak (PK)
FREQUENCY RANGE	1GHz ~ 25GHz		Average (AV)

ANTENNA POLARITY & TEST DISTANCE: VERTICAL AT 3 M								
NO.	FREQ. (MHz)	EMISSION LEVEL (dBuV/m)	LIMIT (dBuV/m)	MARGIN (dB)	ANTENNA HEIGHT (m)	TABLE ANGLE (Degree)	RAW VALUE (dBuV)	CORRECTION FACTOR (dB/m)
1	2390.00	70.6 PK	74.0	-3.4	3.71 V	347	74.83	-4.23
2	2390.00	51.3 AV	54.0	-2.7	3.71 V	347	55.53	-4.23
3	*2422.00	100.7 PK			3.71 V	347	104.82	-4.12
4	*2422.00	90.4 AV			3.71 V	347	94.52	-4.12

REMARKS:

1. Emission Level(dBuV/m) = Raw Value(dBuV) + Correction Factor(dB/m)
2. Correction Factor(dB/m) = Antenna Factor(dB/m) + Cable Factor(dB) – Pre-Amplifier Factor(dB)
3. The other emission levels were very low against the limit.
4. Margin value = Emission Level – Limit value
5. " * ": Fundamental frequency.

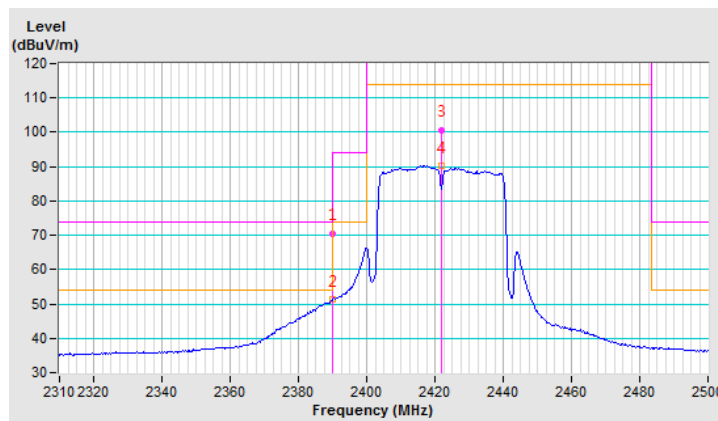

Antenna 2

CHANNEL	TX Channel 6	DETECTOR FUNCTION	Peak (PK)
FREQUENCY RANGE	1GHz ~ 25GHz		Average (AV)

ANTENNA POLARITY & TEST DISTANCE: HORIZONTAL AT 3 M

NO.	FREQ. (MHz)	EMISSION LEVEL (dBuV/m)	LIMIT (dBuV/m)	MARGIN (dB)	ANTENNA HEIGHT (m)	TABLE ANGLE (Degree)	RAW VALUE (dBuV)	CORRECTION FACTOR (dB/m)
1	2390.00	73.9 PK	74.0	-0.1	2.79 H	306	78.13	-4.23
2	2390.00	53.9 AV	54.0	-0.1	2.79 H	306	58.13	-4.23
3	*2437.00	105.1 PK			2.79 H	306	109.19	-4.09
4	*2437.00	94.7 AV			2.79 H	306	98.79	-4.09
5	2483.50	70.1 PK	74.0	-3.9	2.79 H	306	74.05	-3.95
6	2483.50	45.9 AV	54.0	-8.1	2.79 H	306	49.85	-3.95

REMARKS:

1. Emission Level(dBuV/m) = Raw Value(dBuV) + Correction Factor(dB/m)
2. Correction Factor(dB/m) = Antenna Factor(dB/m) + Cable Factor(dB) – Pre-Amplifier Factor(dB)
3. The other emission levels were very low against the limit.
4. Margin value = Emission Level – Limit value
5. " * ": Fundamental frequency.

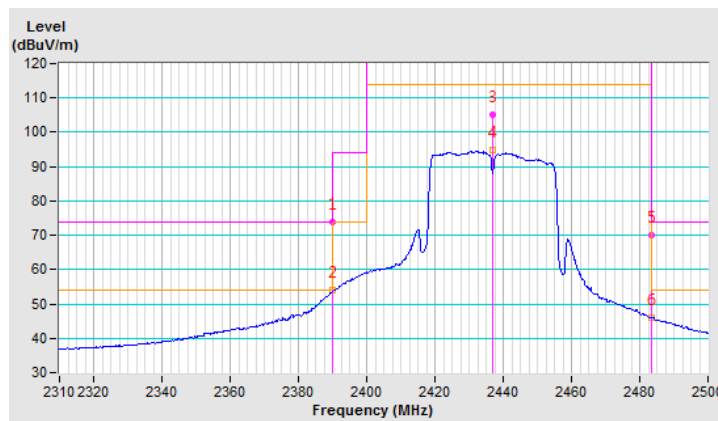

Antenna 2

CHANNEL	TX Channel 6	DETECTOR FUNCTION	Peak (PK)
FREQUENCY RANGE	1GHz ~ 25GHz		Average (AV)

ANTENNA POLARITY & TEST DISTANCE: VERTICAL AT 3 M								
NO.	FREQ. (MHz)	EMISSION LEVEL (dBuV/m)	LIMIT (dBuV/m)	MARGIN (dB)	ANTENNA HEIGHT (m)	TABLE ANGLE (Degree)	RAW VALUE (dBuV)	CORRECTION FACTOR (dB/m)
1	2390.00	68.5 PK	74.0	-5.5	3.74 V	344	72.73	-4.23
2	2390.00	51.6 AV	54.0	-2.4	3.74 V	344	55.83	-4.23
3	*2437.00	103.0 PK			3.74 V	344	107.09	-4.09
4	*2437.00	92.2 AV			3.74 V	344	96.29	-4.09
5	2483.50	66.9 PK	74.0	-7.1	3.74 V	344	70.85	-3.95
6	2483.50	43.6 AV	54.0	-10.4	3.74 V	344	47.55	-3.95

REMARKS:

1. Emission Level(dBuV/m) = Raw Value(dBuV) + Correction Factor(dB/m)
2. Correction Factor(dB/m) = Antenna Factor(dB/m) + Cable Factor(dB) – Pre-Amplifier Factor(dB)
3. The other emission levels were very low against the limit.
4. Margin value = Emission Level – Limit value
5. " * ": Fundamental frequency.

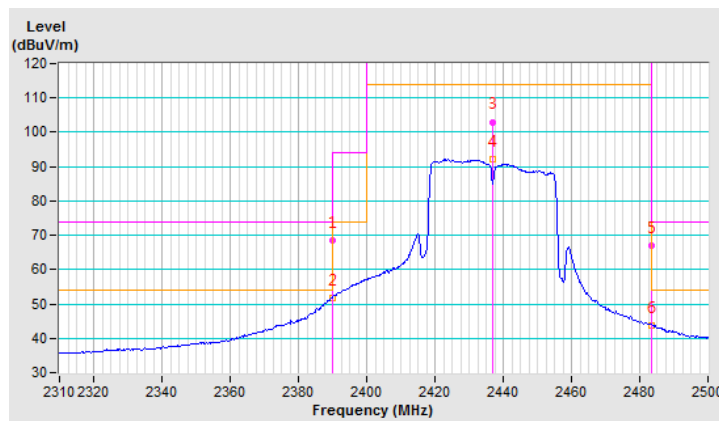

Antenna 2

CHANNEL	TX Channel 9	DETECTOR FUNCTION	Peak (PK)
FREQUENCY RANGE	1GHz ~ 25GHz		Average (AV)

ANTENNA POLARITY & TEST DISTANCE: HORIZONTAL AT 3 M								
NO.	FREQ. (MHz)	EMISSION LEVEL (dBuV/m)	LIMIT (dBuV/m)	MARGIN (dB)	ANTENNA HEIGHT (m)	TABLE ANGLE (Degree)	RAW VALUE (dBuV)	CORRECTION FACTOR (dB/m)
1	*2452.00	105.0 PK			2.71 H	304	109.05	-4.05
2	*2452.00	94.7 AV			2.71 H	304	98.75	-4.05
3	2483.50	73.9 PK	74.0	-0.1	2.71 H	304	77.85	-3.95
4	2483.50	49.3 AV	54.0	-4.7	2.71 H	304	53.25	-3.95

REMARKS:

1. Emission Level(dBuV/m) = Raw Value(dBuV) + Correction Factor(dB/m)
2. Correction Factor(dB/m) = Antenna Factor(dB/m) + Cable Factor(dB) – Pre-Amplifier Factor(dB)
3. The other emission levels were very low against the limit.
4. Margin value = Emission Level – Limit value
5. " * ": Fundamental frequency.

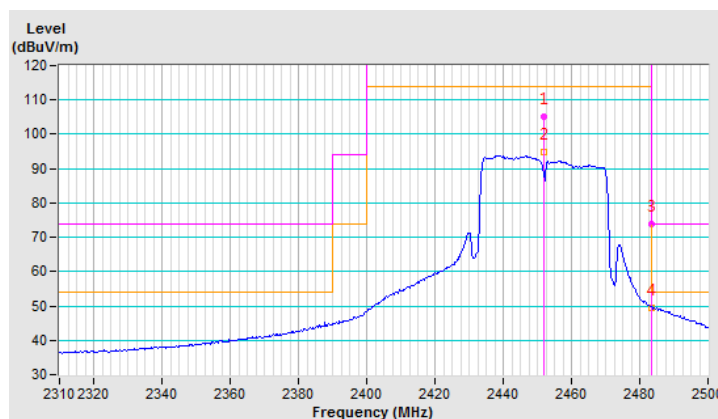

Antenna 2

CHANNEL	TX Channel 9	DETECTOR FUNCTION	Peak (PK)
FREQUENCY RANGE	1GHz ~ 25GHz		Average (AV)

ANTENNA POLARITY & TEST DISTANCE: VERTICAL AT 3 M								
NO.	FREQ. (MHz)	EMISSION LEVEL (dBuV/m)	LIMIT (dBuV/m)	MARGIN (dB)	ANTENNA HEIGHT (m)	TABLE ANGLE (Degree)	RAW VALUE (dBuV)	CORRECTION FACTOR (dB/m)
1	*2452.00	101.5 PK			3.74 V	346	105.55	-4.05
2	*2452.00	91.3 AV			3.74 V	346	95.35	-4.05
3	2483.50	70.7 PK	74.0	-3.3	3.74 V	346	74.65	-3.95
4	2483.50	46.8 AV	54.0	-7.2	3.74 V	346	50.75	-3.95

REMARKS:

1. Emission Level(dBuV/m) = Raw Value(dBuV) + Correction Factor(dB/m)
2. Correction Factor(dB/m) = Antenna Factor(dB/m) + Cable Factor(dB) – Pre-Amplifier Factor(dB)
3. The other emission levels were very low against the limit.
4. Margin value = Emission Level – Limit value
5. " * ": Fundamental frequency.

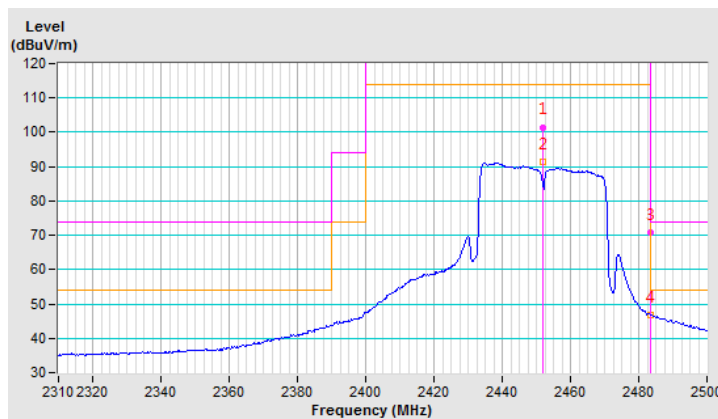

2TX

802.11g

CHANNEL	TX Channel 1	DETECTOR FUNCTION	Peak (PK)
FREQUENCY RANGE	1GHz ~ 25GHz		Average (AV)

ANTENNA POLARITY & TEST DISTANCE: HORIZONTAL AT 3 M								
NO.	FREQ. (MHz)	EMISSION LEVEL (dBuV/m)	LIMIT (dBuV/m)	MARGIN (dB)	ANTENNA HEIGHT (m)	TABLE ANGLE (Degree)	RAW VALUE (dBuV)	CORRECTION FACTOR (dB/m)
1	2390.00	72.7 PK	74.0	-1.3	1.00 H	85	76.93	-4.23
2	2390.00	45.5 AV	54.0	-8.5	1.00 H	85	49.73	-4.23
3	*2412.00	105.9 PK			1.00 H	85	110.06	-4.16
4	*2412.00	96.4 AV			1.00 H	85	100.56	-4.16

REMARKS:

1. Emission Level(dBuV/m) = Raw Value(dBuV) + Correction Factor(dB/m)
2. Correction Factor(dB/m) = Antenna Factor(dB/m) + Cable Factor(dB) – Pre-Amplifier Factor(dB)
3. The other emission levels were very low against the limit.
4. Margin value = Emission Level – Limit value
5. " * ": Fundamental frequency.

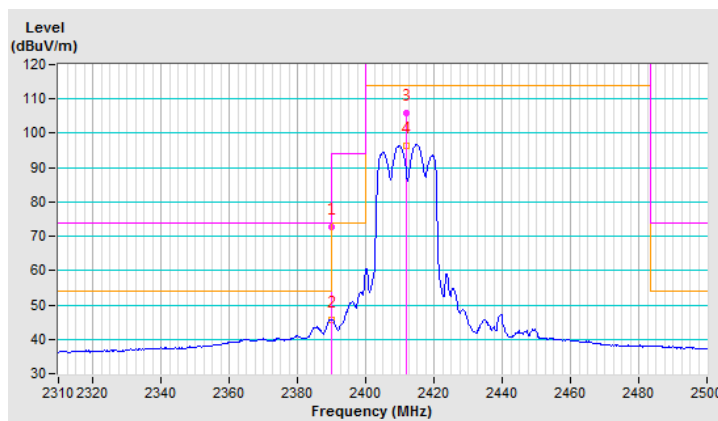

CHANNEL	TX Channel 1	DETECTOR FUNCTION	Peak (PK)
FREQUENCY RANGE	1GHz ~ 25GHz		Average (AV)

ANTENNA POLARITY & TEST DISTANCE: VERTICAL AT 3 M

NO.	FREQ. (MHz)	EMISSION LEVEL (dBuV/m)	LIMIT (dBuV/m)	MARGIN (dB)	ANTENNA HEIGHT (m)	TABLE ANGLE (Degree)	RAW VALUE (dBuV)	CORRECTION FACTOR (dB/m)
1	2390.00	70.7 PK	74.0	-3.3	2.76 V	5	74.93	-4.23
2	2390.00	45.1 AV	54.0	-8.9	2.76 V	5	49.33	-4.23
3	*2412.00	106.2 PK			2.76 V	5	110.36	-4.16
4	*2412.00	96.9 AV			2.76 V	5	101.06	-4.16

REMARKS:

1. Emission Level(dBuV/m) = Raw Value(dBuV) + Correction Factor(dB/m)
2. Correction Factor(dB/m) = Antenna Factor(dB/m) + Cable Factor(dB) – Pre-Amplifier Factor(dB)
3. The other emission levels were very low against the limit.
4. Margin value = Emission Level – Limit value
5. " * ": Fundamental frequency.

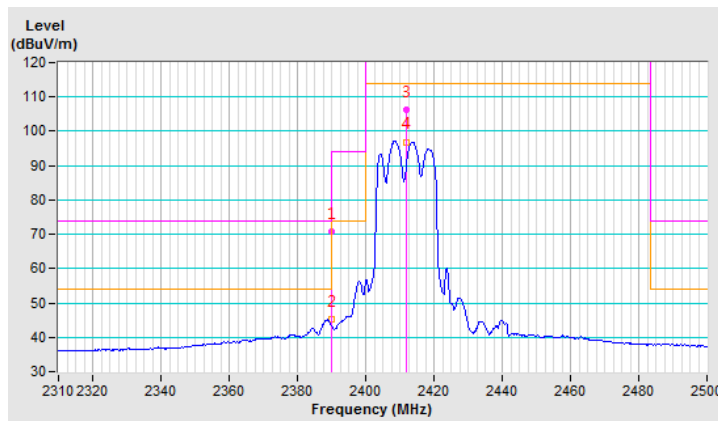

CHANNEL	TX Channel 6	DETECTOR FUNCTION	Peak (PK)
FREQUENCY RANGE	1GHz ~ 25GHz		Average (AV)

ANTENNA POLARITY & TEST DISTANCE: HORIZONTAL AT 3 M

NO.	FREQ. (MHz)	EMISSION LEVEL (dBuV/m)	LIMIT (dBuV/m)	MARGIN (dB)	ANTENNA HEIGHT (m)	TABLE ANGLE (Degree)	RAW VALUE (dBuV)	CORRECTION FACTOR (dB/m)
1	2390.00	72.4 PK	74.0	-1.6	1.00 H	83	76.63	-4.23
2	2390.00	53.9 AV	54.0	-0.1	1.00 H	83	58.13	-4.23
3	*2437.00	113.1 PK			1.00 H	83	117.19	-4.09
4	*2437.00	103.6 AV			1.00 H	83	107.69	-4.09
5	2483.50	70.2 PK	74.0	-3.8	1.00 H	83	74.15	-3.95
6	2483.50	51.4 AV	54.0	-2.6	1.00 H	83	55.35	-3.95

REMARKS:

1. Emission Level(dBuV/m) = Raw Value(dBuV) + Correction Factor(dB/m)
2. Correction Factor(dB/m) = Antenna Factor(dB/m) + Cable Factor(dB) – Pre-Amplifier Factor(dB)
3. The other emission levels were very low against the limit.
4. Margin value = Emission Level – Limit value
5. " * ": Fundamental frequency.

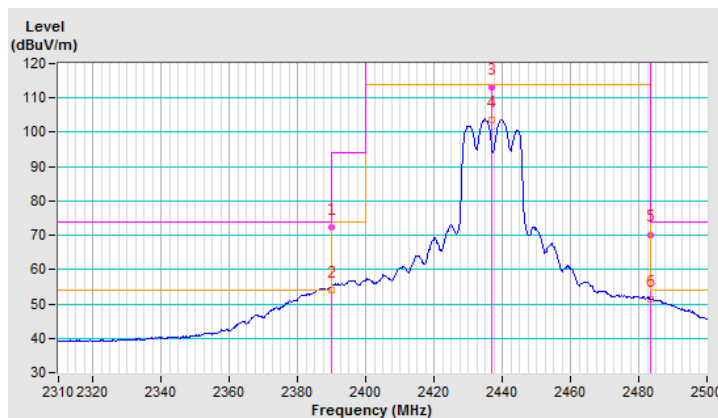

CHANNEL	TX Channel 6	DETECTOR FUNCTION	Peak (PK)
FREQUENCY RANGE	1GHz ~ 25GHz		Average (AV)

ANTENNA POLARITY & TEST DISTANCE: VERTICAL AT 3 M

NO.	FREQ. (MHz)	EMISSION LEVEL (dBuV/m)	LIMIT (dBuV/m)	MARGIN (dB)	ANTENNA HEIGHT (m)	TABLE ANGLE (Degree)	RAW VALUE (dBuV)	CORRECTION FACTOR (dB/m)
1	2390.00	69.4 PK	74.0	-4.6	2.12 V	4	73.63	-4.23
2	2390.00	52.6 AV	54.0	-1.4	2.12 V	4	56.83	-4.23
3	*2437.00	112.3 PK			2.12 V	4	116.39	-4.09
4	*2437.00	103.3 AV			2.12 V	4	107.39	-4.09
5	2483.50	67.1 PK	74.0	-6.9	2.12 V	4	71.05	-3.95
6	2483.50	48.9 AV	54.0	-5.1	2.12 V	4	52.85	-3.95

REMARKS:

1. Emission Level(dBuV/m) = Raw Value(dBuV) + Correction Factor(dB/m)
2. Correction Factor(dB/m) = Antenna Factor(dB/m) + Cable Factor(dB) – Pre-Amplifier Factor(dB)
3. The other emission levels were very low against the limit.
4. Margin value = Emission Level – Limit value
5. " * ": Fundamental frequency.

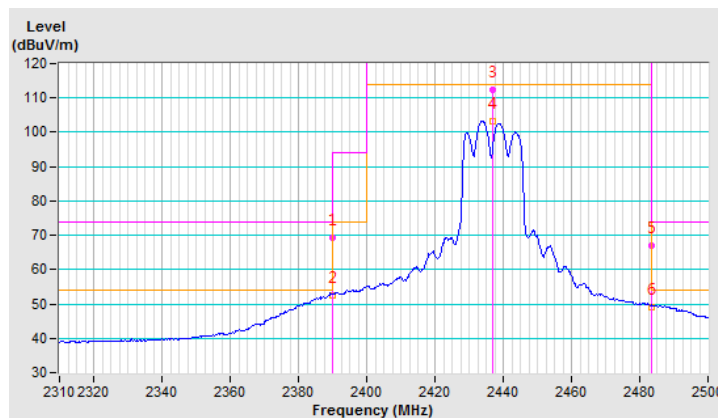

CHANNEL	TX Channel 11	DETECTOR FUNCTION	Peak (PK)
FREQUENCY RANGE	1GHz ~ 25GHz		Average (AV)

ANTENNA POLARITY & TEST DISTANCE: HORIZONTAL AT 3 M

NO.	FREQ. (MHz)	EMISSION LEVEL (dBuV/m)	LIMIT (dBuV/m)	MARGIN (dB)	ANTENNA HEIGHT (m)	TABLE ANGLE (Degree)	RAW VALUE (dBuV)	CORRECTION FACTOR (dB/m)
1	*2462.00	106.2 PK			1.00 H	84	110.21	-4.01
2	*2462.00	97.0 AV			1.00 H	84	101.01	-4.01
3	2483.50	72.0 PK	74.0	-2.0	1.00 H	84	75.95	-3.95
4	2483.50	45.2 AV	54.0	-8.8	1.00 H	84	49.15	-3.95

REMARKS:

1. Emission Level(dBuV/m) = Raw Value(dBuV) + Correction Factor(dB/m)
2. Correction Factor(dB/m) = Antenna Factor(dB/m) + Cable Factor(dB) – Pre-Amplifier Factor(dB)
3. The other emission levels were very low against the limit.
4. Margin value = Emission Level – Limit value
5. " * ": Fundamental frequency.

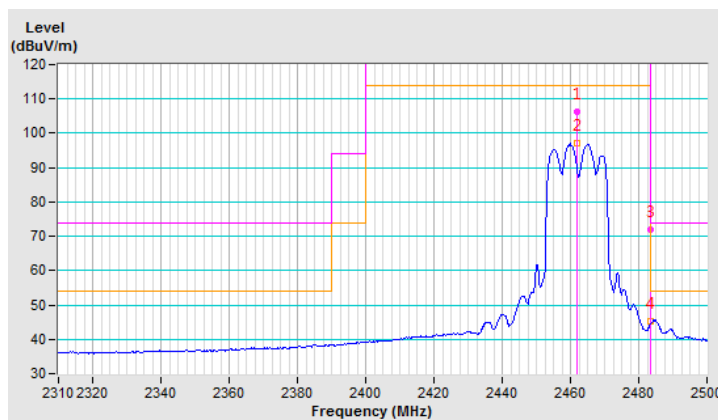

CHANNEL	TX Channel 11	DETECTOR FUNCTION	Peak (PK)
FREQUENCY RANGE	1GHz ~ 25GHz		Average (AV)

ANTENNA POLARITY & TEST DISTANCE: VERTICAL AT 3 M

NO.	FREQ. (MHz)	EMISSION LEVEL (dBuV/m)	LIMIT (dBuV/m)	MARGIN (dB)	ANTENNA HEIGHT (m)	TABLE ANGLE (Degree)	RAW VALUE (dBuV)	CORRECTION FACTOR (dB/m)
1	*2462.00	105.4 PK			2.12 V	0	109.41	-4.01
2	*2462.00	95.8 AV			2.12 V	0	99.81	-4.01
3	2483.50	69.8 PK	74.0	-4.2	2.12 V	0	73.75	-3.95
4	2483.50	43.7 AV	54.0	-10.3	2.12 V	0	47.65	-3.95

REMARKS:

1. Emission Level(dBuV/m) = Raw Value(dBuV) + Correction Factor(dB/m)
2. Correction Factor(dB/m) = Antenna Factor(dB/m) + Cable Factor(dB) – Pre-Amplifier Factor(dB)
3. The other emission levels were very low against the limit.
4. Margin value = Emission Level – Limit value
5. " * ": Fundamental frequency.

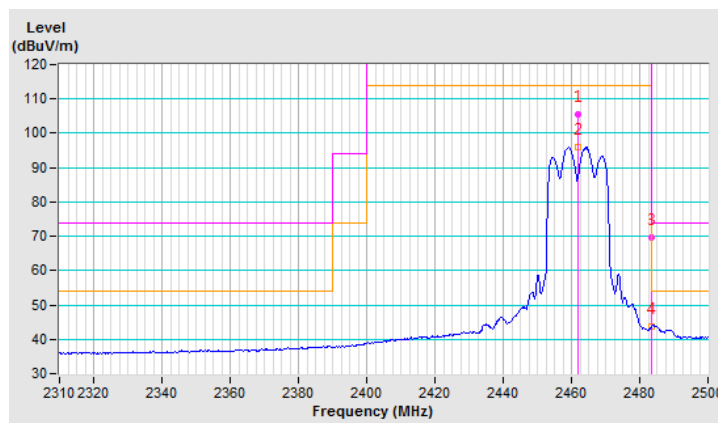

802.11n (20MHz)

CHANNEL	TX Channel 1	DETECTOR FUNCTION	Peak (PK)
FREQUENCY RANGE	1GHz ~ 25GHz		Average (AV)

ANTENNA POLARITY & TEST DISTANCE: HORIZONTAL AT 3 M								
NO.	FREQ. (MHz)	EMISSION LEVEL (dBuV/m)	LIMIT (dBuV/m)	MARGIN (dB)	ANTENNA HEIGHT (m)	TABLE ANGLE (Degree)	RAW VALUE (dBuV)	CORRECTION FACTOR (dB/m)
1	2390.00	73.7 PK	74.0	-0.3	1.00 H	85	77.93	-4.23
2	2390.00	48.1 AV	54.0	-5.9	1.00 H	85	52.33	-4.23
3	*2412.00	107.2 PK			1.00 H	85	111.36	-4.16
4	*2412.00	97.7 AV			1.00 H	85	101.86	-4.16

REMARKS:

1. Emission Level(dBuV/m) = Raw Value(dBuV) + Correction Factor(dB/m)
2. Correction Factor(dB/m) = Antenna Factor(dB/m) + Cable Factor(dB) – Pre-Amplifier Factor(dB)
3. The other emission levels were very low against the limit.
4. Margin value = Emission Level – Limit value
5. " * ": Fundamental frequency.

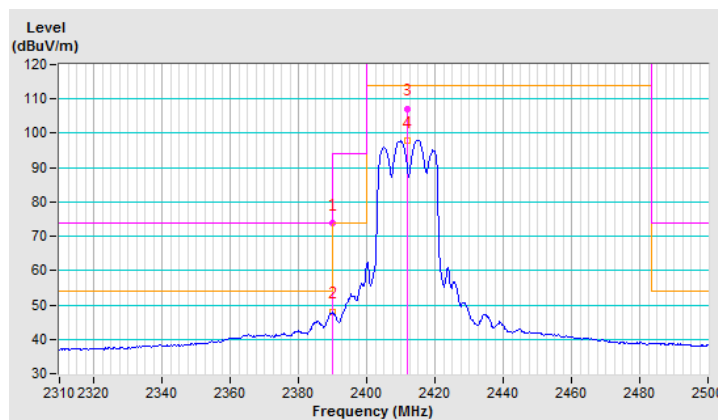

CHANNEL	TX Channel 1	DETECTOR FUNCTION	Peak (PK)
FREQUENCY RANGE	1GHz ~ 25GHz		Average (AV)

ANTENNA POLARITY & TEST DISTANCE: VERTICAL AT 3 M

NO.	FREQ. (MHz)	EMISSION LEVEL (dBuV/m)	LIMIT (dBuV/m)	MARGIN (dB)	ANTENNA HEIGHT (m)	TABLE ANGLE (Degree)	RAW VALUE (dBuV)	CORRECTION FACTOR (dB/m)
1	2390.00	71.7 PK	74.0	-2.3	2.38 V	11	75.93	-4.23
2	2390.00	46.2 AV	54.0	-7.8	2.38 V	11	50.43	-4.23
3	*2412.00	107.2 PK			2.38 V	11	111.36	-4.16
4	*2412.00	97.0 AV			2.38 V	11	101.16	-4.16

REMARKS:

1. Emission Level(dBuV/m) = Raw Value(dBuV) + Correction Factor(dB/m)
2. Correction Factor(dB/m) = Antenna Factor(dB/m) + Cable Factor(dB) – Pre-Amplifier Factor(dB)
3. The other emission levels were very low against the limit.
4. Margin value = Emission Level – Limit value
5. " * ": Fundamental frequency.

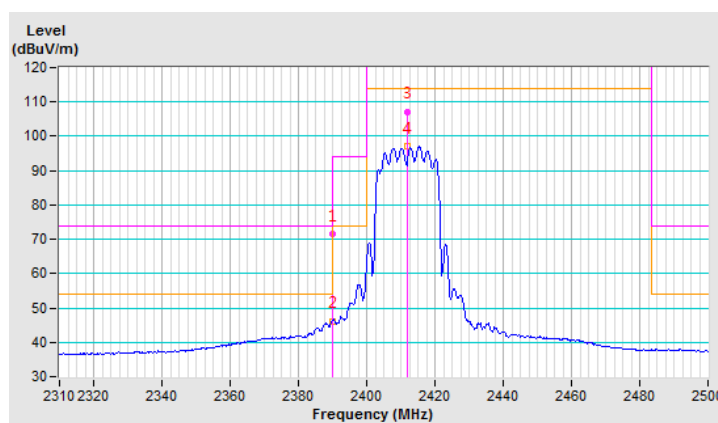

CHANNEL	TX Channel 6	DETECTOR FUNCTION	Peak (PK)
FREQUENCY RANGE	1GHz ~ 25GHz		Average (AV)

ANTENNA POLARITY & TEST DISTANCE: HORIZONTAL AT 3 M

NO.	FREQ. (MHz)	EMISSION LEVEL (dBuV/m)	LIMIT (dBuV/m)	MARGIN (dB)	ANTENNA HEIGHT (m)	TABLE ANGLE (Degree)	RAW VALUE (dBuV)	CORRECTION FACTOR (dB/m)
1	2390.00	71.2 PK	74.0	-2.8	1.00 H	85	75.43	-4.23
2	2390.00	53.7 AV	54.0	-0.3	1.00 H	85	57.93	-4.23
3	*2437.00	112.6 PK			1.00 H	85	116.69	-4.09
4	*2437.00	103.7 AV			1.00 H	85	107.79	-4.09
5	2483.50	68.7 PK	74.0	-5.3	1.00 H	85	72.65	-3.95
6	2483.50	50.4 AV	54.0	-3.6	1.00 H	85	54.35	-3.95

REMARKS:

1. Emission Level(dBuV/m) = Raw Value(dBuV) + Correction Factor(dB/m)
2. Correction Factor(dB/m) = Antenna Factor(dB/m) + Cable Factor(dB) – Pre-Amplifier Factor(dB)
3. The other emission levels were very low against the limit.
4. Margin value = Emission Level – Limit value
5. " * ": Fundamental frequency.

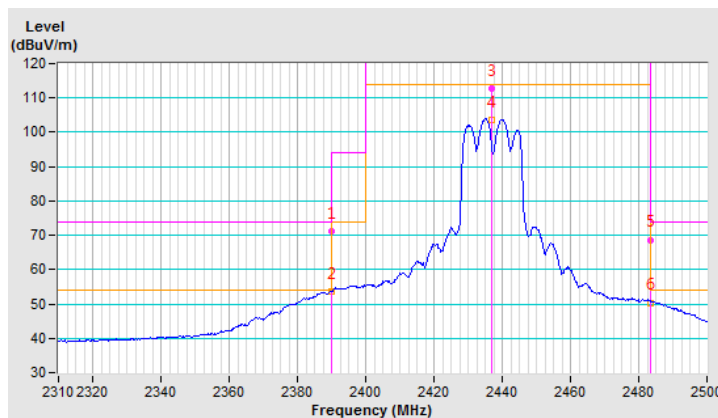

CHANNEL	TX Channel 6	DETECTOR FUNCTION	Peak (PK)
FREQUENCY RANGE	1GHz ~ 25GHz		Average (AV)

ANTENNA POLARITY & TEST DISTANCE: VERTICAL AT 3 M

NO.	FREQ. (MHz)	EMISSION LEVEL (dBuV/m)	LIMIT (dBuV/m)	MARGIN (dB)	ANTENNA HEIGHT (m)	TABLE ANGLE (Degree)	RAW VALUE (dBuV)	CORRECTION FACTOR (dB/m)
1	2390.00	70.1 PK	74.0	-3.9	2.43 V	3	74.33	-4.23
2	2390.00	52.5 AV	54.0	-1.5	2.43 V	3	56.73	-4.23
3	*2437.00	112.4 PK			2.43 V	3	116.49	-4.09
4	*2437.00	102.3 AV			2.43 V	3	106.39	-4.09
5	2483.50	68.8 PK	74.0	-5.2	2.43 V	3	72.75	-3.95
6	2483.50	50.4 AV	54.0	-3.6	2.43 V	3	54.35	-3.95

REMARKS:

1. Emission Level(dBuV/m) = Raw Value(dBuV) + Correction Factor(dB/m)
2. Correction Factor(dB/m) = Antenna Factor(dB/m) + Cable Factor(dB) – Pre-Amplifier Factor(dB)
3. The other emission levels were very low against the limit.
4. Margin value = Emission Level – Limit value
5. " * ": Fundamental frequency.

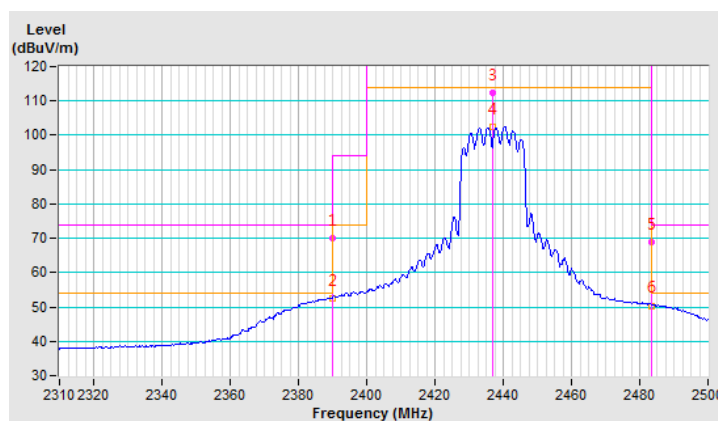

CHANNEL	TX Channel 11	DETECTOR FUNCTION	Peak (PK)
FREQUENCY RANGE	1GHz ~ 25GHz		Average (AV)

ANTENNA POLARITY & TEST DISTANCE: HORIZONTAL AT 3 M

NO.	FREQ. (MHz)	EMISSION LEVEL (dBuV/m)	LIMIT (dBuV/m)	MARGIN (dB)	ANTENNA HEIGHT (m)	TABLE ANGLE (Degree)	RAW VALUE (dBuV)	CORRECTION FACTOR (dB/m)
1	*2462.00	106.5 PK			1.00 H	85	110.51	-4.01
2	*2462.00	97.1 AV			1.00 H	85	101.11	-4.01
3	2483.50	72.7 PK	74.0	-1.3	1.00 H	85	76.65	-3.95
4	2483.50	45.8 AV	54.0	-8.2	1.00 H	85	49.75	-3.95

REMARKS:

1. Emission Level(dBuV/m) = Raw Value(dBuV) + Correction Factor(dB/m)
2. Correction Factor(dB/m) = Antenna Factor(dB/m) + Cable Factor(dB) – Pre-Amplifier Factor(dB)
3. The other emission levels were very low against the limit.
4. Margin value = Emission Level – Limit value
5. " * ": Fundamental frequency.

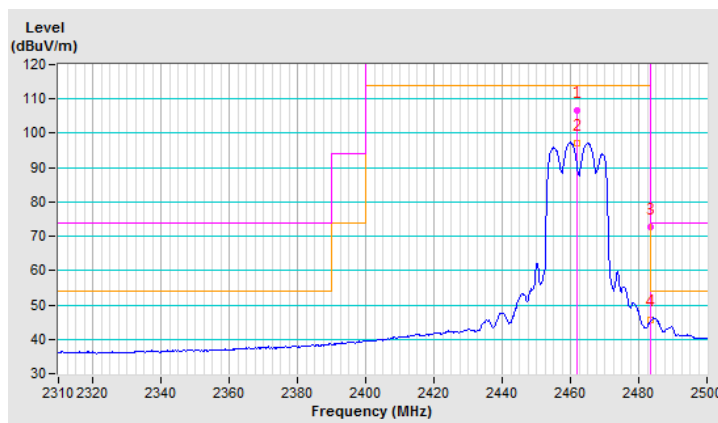

CHANNEL	TX Channel 11	DETECTOR FUNCTION	Peak (PK)
FREQUENCY RANGE	1GHz ~ 25GHz		Average (AV)

ANTENNA POLARITY & TEST DISTANCE: VERTICAL AT 3 M

NO.	FREQ. (MHz)	EMISSION LEVEL (dBuV/m)	LIMIT (dBuV/m)	MARGIN (dB)	ANTENNA HEIGHT (m)	TABLE ANGLE (Degree)	RAW VALUE (dBuV)	CORRECTION FACTOR (dB/m)
1	*2462.00	106.3 PK			2.42 V	4	110.31	-4.01
2	*2462.00	96.7 AV			2.42 V	4	100.71	-4.01
3	2483.50	70.8 PK	74.0	-3.2	2.42 V	4	74.75	-3.95
4	2483.50	44.4 AV	54.0	-9.6	2.42 V	4	48.35	-3.95

REMARKS:

1. Emission Level(dBuV/m) = Raw Value(dBuV) + Correction Factor(dB/m)
2. Correction Factor(dB/m) = Antenna Factor(dB/m) + Cable Factor(dB) – Pre-Amplifier Factor(dB)
3. The other emission levels were very low against the limit.
4. Margin value = Emission Level – Limit value
5. " * ": Fundamental frequency.

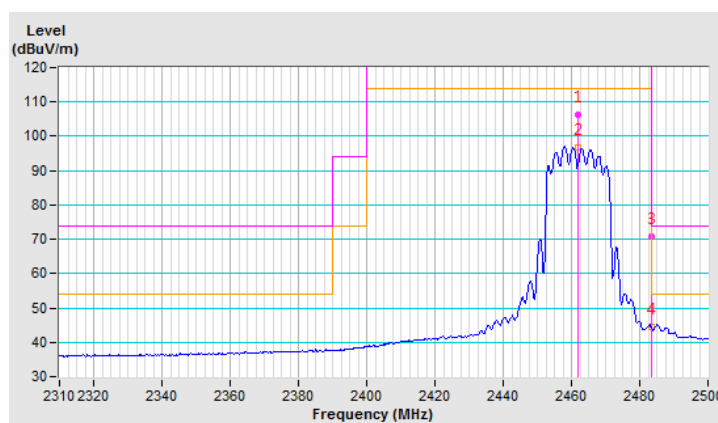

802.11n (40MHz)

CHANNEL	TX Channel 3	DETECTOR FUNCTION	Peak (PK)
FREQUENCY RANGE	1GHz ~ 25GHz		Average (AV)

ANTENNA POLARITY & TEST DISTANCE: HORIZONTAL AT 3 M								
NO.	FREQ. (MHz)	EMISSION LEVEL (dBuV/m)	LIMIT (dBuV/m)	MARGIN (dB)	ANTENNA HEIGHT (m)	TABLE ANGLE (Degree)	RAW VALUE (dBuV)	CORRECTION FACTOR (dB/m)
1	2390.00	73.7 PK	74.0	-0.3	1.00 H	84	77.93	-4.23
2	2390.00	53.6 AV	54.0	-0.4	1.00 H	84	57.83	-4.23
3	*2422.00	101.8 PK			1.00 H	84	105.92	-4.12
4	*2422.00	92.4 AV			1.00 H	84	96.52	-4.12

REMARKS:

1. Emission Level(dBuV/m) = Raw Value(dBuV) + Correction Factor(dB/m)
2. Correction Factor(dB/m) = Antenna Factor(dB/m) + Cable Factor(dB) – Pre-Amplifier Factor(dB)
3. The other emission levels were very low against the limit.
4. Margin value = Emission Level – Limit value
5. " * ": Fundamental frequency.

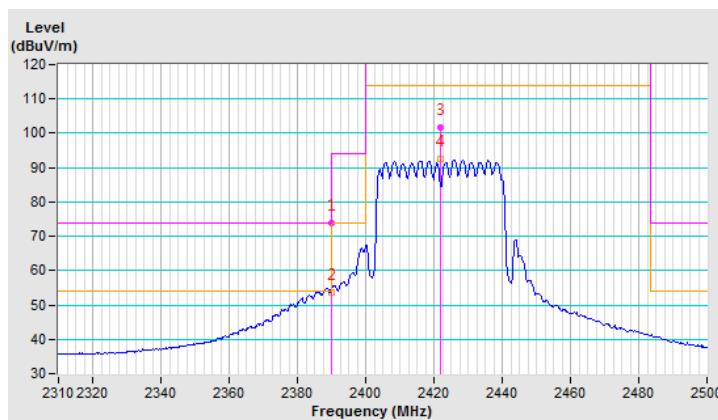

CHANNEL	TX Channel 3	DETECTOR FUNCTION	Peak (PK)
FREQUENCY RANGE	1GHz ~ 25GHz		Average (AV)

ANTENNA POLARITY & TEST DISTANCE: VERTICAL AT 3 M

NO.	FREQ. (MHz)	EMISSION LEVEL (dBuV/m)	LIMIT (dBuV/m)	MARGIN (dB)	ANTENNA HEIGHT (m)	TABLE ANGLE (Degree)	RAW VALUE (dBuV)	CORRECTION FACTOR (dB/m)
1	2390.00	73.9 PK	74.0	-0.1	2.54 V	3	78.13	-4.23
2	2390.00	53.9 AV	54.0	-0.1	2.54 V	3	58.13	-4.23
3	*2422.00	101.4 PK			2.54 V	3	105.52	-4.12
4	*2422.00	92.7 AV			2.54 V	3	96.82	-4.12

REMARKS:

1. Emission Level(dBuV/m) = Raw Value(dBuV) + Correction Factor(dB/m)
2. Correction Factor(dB/m) = Antenna Factor(dB/m) + Cable Factor(dB) – Pre-Amplifier Factor(dB)
3. The other emission levels were very low against the limit.
4. Margin value = Emission Level – Limit value
5. " * ": Fundamental frequency.

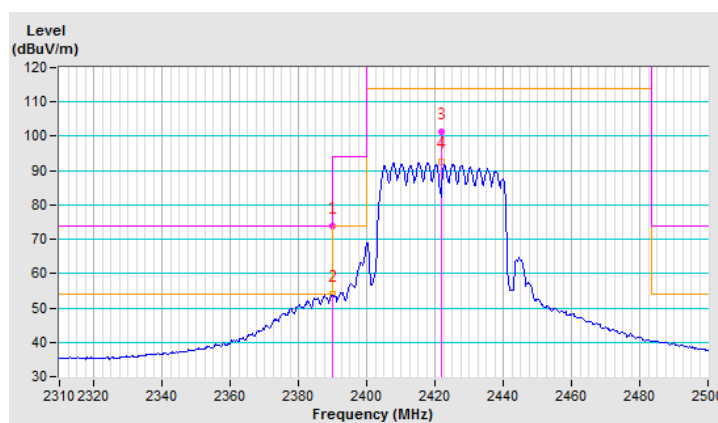

CHANNEL	TX Channel 6	DETECTOR FUNCTION	Peak (PK)
FREQUENCY RANGE	1GHz ~ 25GHz		Average (AV)

ANTENNA POLARITY & TEST DISTANCE: HORIZONTAL AT 3 M

NO.	FREQ. (MHz)	EMISSION LEVEL (dBuV/m)	LIMIT (dBuV/m)	MARGIN (dB)	ANTENNA HEIGHT (m)	TABLE ANGLE (Degree)	RAW VALUE (dBuV)	CORRECTION FACTOR (dB/m)
1	2390.00	73.9 PK	74.0	-0.1	1.00 H	83	78.13	-4.23
2	2390.00	53.6 AV	54.0	-0.4	1.00 H	83	57.83	-4.23
3	*2437.00	104.0 PK			1.00 H	83	108.09	-4.09
4	*2437.00	94.5 AV			1.00 H	83	98.59	-4.09
5	2483.50	71.7 PK	74.0	-2.3	1.00 H	83	75.65	-3.95
6	2483.50	49.1 AV	54.0	-4.9	1.00 H	83	53.05	-3.95

REMARKS:

1. Emission Level(dBuV/m) = Raw Value(dBuV) + Correction Factor(dB/m)
2. Correction Factor(dB/m) = Antenna Factor(dB/m) + Cable Factor(dB) – Pre-Amplifier Factor(dB)
3. The other emission levels were very low against the limit.
4. Margin value = Emission Level – Limit value
5. " * ": Fundamental frequency.

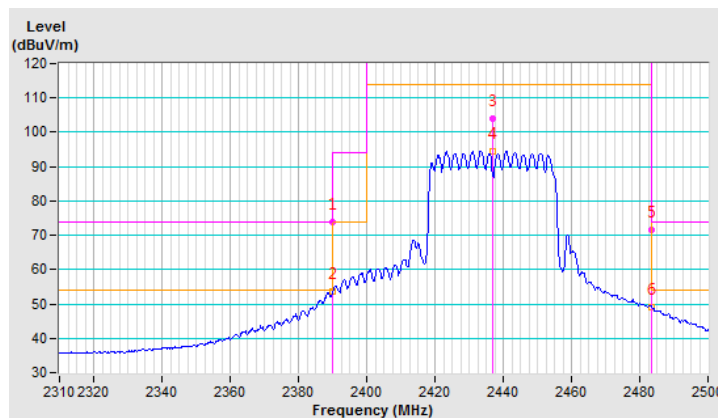

CHANNEL	TX Channel 6	DETECTOR FUNCTION	Peak (PK)
FREQUENCY RANGE	1GHz ~ 25GHz		Average (AV)

ANTENNA POLARITY & TEST DISTANCE: VERTICAL AT 3 M

NO.	FREQ. (MHz)	EMISSION LEVEL (dBuV/m)	LIMIT (dBuV/m)	MARGIN (dB)	ANTENNA HEIGHT (m)	TABLE ANGLE (Degree)	RAW VALUE (dBuV)	CORRECTION FACTOR (dB/m)
1	2390.00	71.4 PK	74.0	-2.6	2.68 V	360	75.63	-4.23
2	2390.00	53.3 AV	54.0	-0.7	2.68 V	360	57.53	-4.23
3	*2437.00	103.9 PK			2.68 V	360	107.99	-4.09
4	*2437.00	94.6 AV			2.68 V	360	98.69	-4.09
5	2483.50	70.3 PK	74.0	-3.7	2.68 V	360	74.25	-3.95
6	2483.50	48.8 AV	54.0	-5.2	2.68 V	360	52.75	-3.95

REMARKS:

1. Emission Level(dBuV/m) = Raw Value(dBuV) + Correction Factor(dB/m)
2. Correction Factor(dB/m) = Antenna Factor(dB/m) + Cable Factor(dB) – Pre-Amplifier Factor(dB)
3. The other emission levels were very low against the limit.
4. Margin value = Emission Level – Limit value
5. " * ": Fundamental frequency.

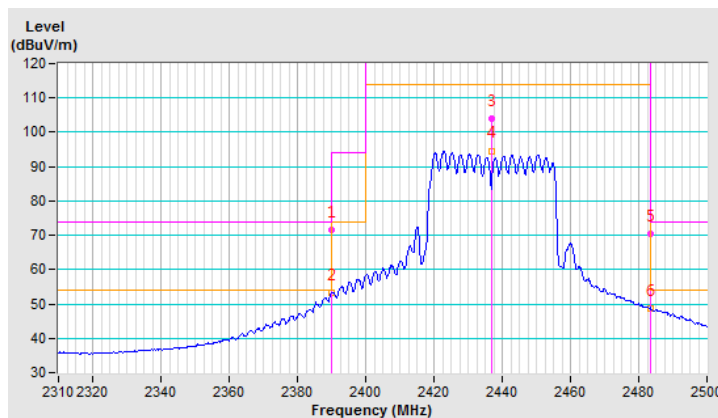

CHANNEL	TX Channel 9	DETECTOR FUNCTION	Peak (PK)
FREQUENCY RANGE	1GHz ~ 25GHz		Average (AV)

ANTENNA POLARITY & TEST DISTANCE: HORIZONTAL AT 3 M

NO.	FREQ. (MHz)	EMISSION LEVEL (dBuV/m)	LIMIT (dBuV/m)	MARGIN (dB)	ANTENNA HEIGHT (m)	TABLE ANGLE (Degree)	RAW VALUE (dBuV)	CORRECTION FACTOR (dB/m)
1	*2452.00	102.1 PK			1.00 H	81	106.15	-4.05
2	*2452.00	92.8 AV			1.00 H	81	96.85	-4.05
3	2483.50	73.9 PK	74.0	-0.1	1.00 H	81	77.85	-3.95
4	2483.50	50.8 AV	54.0	-3.2	1.00 H	81	54.75	-3.95

REMARKS:

1. Emission Level(dBuV/m) = Raw Value(dBuV) + Correction Factor(dB/m)
2. Correction Factor(dB/m) = Antenna Factor(dB/m) + Cable Factor(dB) – Pre-Amplifier Factor(dB)
3. The other emission levels were very low against the limit.
4. Margin value = Emission Level – Limit value
5. " * ": Fundamental frequency.

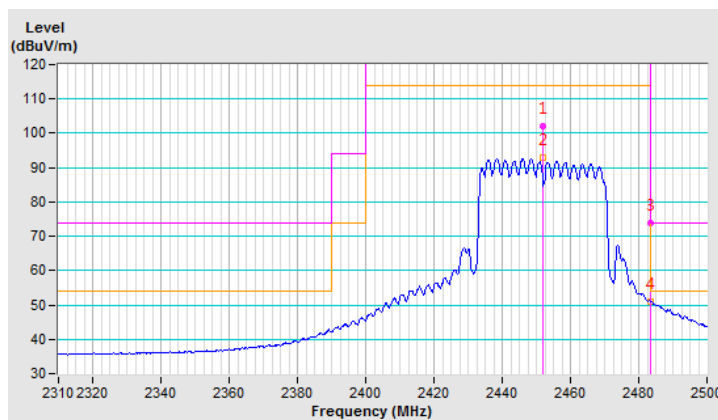

CHANNEL	TX Channel 9	DETECTOR FUNCTION	Peak (PK)
FREQUENCY RANGE	1GHz ~ 25GHz		Average (AV)

ANTENNA POLARITY & TEST DISTANCE: VERTICAL AT 3 M

NO.	FREQ. (MHz)	EMISSION LEVEL (dBuV/m)	LIMIT (dBuV/m)	MARGIN (dB)	ANTENNA HEIGHT (m)	TABLE ANGLE (Degree)	RAW VALUE (dBuV)	CORRECTION FACTOR (dB/m)
1	*2452.00	102.3 PK			2.96 V	4	106.35	-4.05
2	*2452.00	93.2 AV			2.96 V	4	97.25	-4.05
3	2483.50	72.9 PK	74.0	-1.1	2.96 V	4	76.85	-3.95
4	2483.50	49.8 AV	54.0	-4.2	2.96 V	4	53.75	-3.95

REMARKS:

1. Emission Level(dBuV/m) = Raw Value(dBuV) + Correction Factor(dB/m)
2. Correction Factor(dB/m) = Antenna Factor(dB/m) + Cable Factor(dB) – Pre-Amplifier Factor(dB)
3. The other emission levels were very low against the limit.
4. Margin value = Emission Level – Limit value
5. " * ": Fundamental frequency.

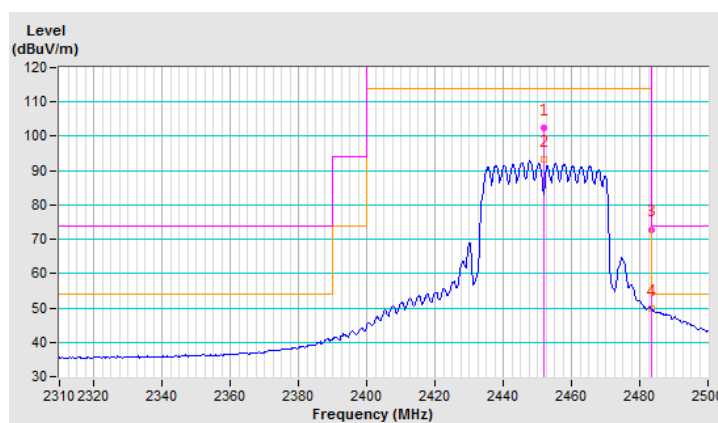

4.1.8 Test Results (Spurious emission)

Above 1GHz Data:

Antenna 1

802.11b

CHANNEL	TX Channel 1	DETECTOR FUNCTION	Peak (PK)
FREQUENCY RANGE	1GHz ~ 25GHz		Average (AV)

ANTENNA POLARITY & TEST DISTANCE: HORIZONTAL AT 3 M

NO.	FREQ. (MHz)	EMISSION LEVEL (dBuV/m)	LIMIT (dBuV/m)	MARGIN (dB)	ANTENNA HEIGHT (m)	TABLE ANGLE (Degree)	RAW VALUE (dBuV)	CORRECTION FACTOR (dB/m)
1	4824.00	45.9 PK	74.0	-28.1	1.35 H	267	43.59	2.31
2	4824.00	40.4 AV	54.0	-13.6	1.35 H	267	38.09	2.31

ANTENNA POLARITY & TEST DISTANCE: VERTICAL AT 3 M

NO.	FREQ. (MHz)	EMISSION LEVEL (dBuV/m)	LIMIT (dBuV/m)	MARGIN (dB)	ANTENNA HEIGHT (m)	TABLE ANGLE (Degree)	RAW VALUE (dBuV)	CORRECTION FACTOR (dB/m)
1	4824.00	44.9 PK	74.0	-29.1	1.00 V	324	42.59	2.31
2	4824.00	39.0 AV	54.0	-15.0	1.00 V	324	36.69	2.31

REMARKS:

1. Emission Level(dBuV/m) = Raw Value(dBuV) + Correction Factor(dB/m)
2. Correction Factor(dB/m) = Antenna Factor(dB/m) + Cable Factor(dB) – Pre-Amplifier Factor(dB)
3. The other emission levels were very low against the limit.
4. Margin value = Emission Level – Limit value

Antenna 1

CHANNEL	TX Channel 6	DETECTOR FUNCTION	Peak (PK)
FREQUENCY RANGE	1GHz ~ 25GHz		Average (AV)

ANTENNA POLARITY & TEST DISTANCE: HORIZONTAL AT 3 M

NO.	FREQ. (MHz)	EMISSION LEVEL (dBuV/m)	LIMIT (dBuV/m)	MARGIN (dB)	ANTENNA HEIGHT (m)	TABLE ANGLE (Degree)	RAW VALUE (dBuV)	CORRECTION FACTOR (dB/m)
1	4874.00	46.1 PK	74.0	-27.9	1.32 H	261	43.69	2.41
2	4874.00	40.8 AV	54.0	-13.2	1.32 H	261	38.39	2.41
3	7311.00	46.9 PK	74.0	-27.1	1.43 H	264	37.96	8.94
4	7311.00	35.5 AV	54.0	-18.5	1.43 H	264	26.56	8.94

ANTENNA POLARITY & TEST DISTANCE: VERTICAL AT 3 M

NO.	FREQ. (MHz)	EMISSION LEVEL (dBuV/m)	LIMIT (dBuV/m)	MARGIN (dB)	ANTENNA HEIGHT (m)	TABLE ANGLE (Degree)	RAW VALUE (dBuV)	CORRECTION FACTOR (dB/m)
1	4874.00	45.2 PK	74.0	-28.8	1.00 V	325	42.79	2.41
2	4874.00	39.1 AV	54.0	-14.9	1.00 V	325	36.69	2.41
3	7311.00	46.2 PK	74.0	-27.8	2.33 V	316	37.26	8.94
4	7311.00	34.8 AV	54.0	-19.2	2.33 V	316	25.86	8.94

REMARKS:

1. Emission Level(dBuV/m) = Raw Value(dBuV) + Correction Factor(dB/m)
2. Correction Factor(dB/m) = Antenna Factor(dB/m) + Cable Factor(dB) – Pre-Amplifier Factor(dB)
3. The other emission levels were very low against the limit.
4. Margin value = Emission Level – Limit value

Antenna 1

CHANNEL	TX Channel 11	DETECTOR FUNCTION	Peak (PK)
FREQUENCY RANGE	1GHz ~ 25GHz		Average (AV)

ANTENNA POLARITY & TEST DISTANCE: HORIZONTAL AT 3 M

NO.	FREQ. (MHz)	EMISSION LEVEL (dBuV/m)	LIMIT (dBuV/m)	MARGIN (dB)	ANTENNA HEIGHT (m)	TABLE ANGLE (Degree)	RAW VALUE (dBuV)	CORRECTION FACTOR (dB/m)
1	4924.00	45.8 PK	74.0	-28.2	1.29 H	257	43.30	2.50
2	4924.00	40.4 AV	54.0	-13.6	1.29 H	257	37.90	2.50
3	7386.00	46.5 PK	74.0	-27.5	1.45 H	259	37.16	9.34
4	7386.00	35.1 AV	54.0	-18.9	1.45 H	259	25.76	9.34

ANTENNA POLARITY & TEST DISTANCE: VERTICAL AT 3 M

NO.	FREQ. (MHz)	EMISSION LEVEL (dBuV/m)	LIMIT (dBuV/m)	MARGIN (dB)	ANTENNA HEIGHT (m)	TABLE ANGLE (Degree)	RAW VALUE (dBuV)	CORRECTION FACTOR (dB/m)
1	4924.00	45.0 PK	74.0	-29.0	1.05 V	329	42.50	2.50
2	4924.00	38.8 AV	54.0	-15.2	1.05 V	329	36.30	2.50
3	7386.00	46.2 PK	74.0	-27.8	2.31 V	313	36.86	9.34
4	7386.00	35.0 AV	54.0	-19.0	2.31 V	313	25.66	9.34

REMARKS:

1. Emission Level(dBuV/m) = Raw Value(dBuV) + Correction Factor(dB/m)
2. Correction Factor(dB/m) = Antenna Factor(dB/m) + Cable Factor(dB) – Pre-Amplifier Factor(dB)
3. The other emission levels were very low against the limit.
4. Margin value = Emission Level – Limit value



Antenna 1

802.11g

CHANNEL	TX Channel 1	DETECTOR FUNCTION	Peak (PK)
FREQUENCY RANGE	1GHz ~ 25GHz		Average (AV)

ANTENNA POLARITY & TEST DISTANCE: HORIZONTAL AT 3 M

NO.	FREQ. (MHz)	EMISSION LEVEL (dBuV/m)	LIMIT (dBuV/m)	MARGIN (dB)	ANTENNA HEIGHT (m)	TABLE ANGLE (Degree)	RAW VALUE (dBuV)	CORRECTION FACTOR (dB/m)
1	4824.00	40.3 PK	74.0	-33.7	1.37 H	252	37.99	2.31
2	4824.00	30.4 AV	54.0	-23.6	1.37 H	252	28.09	2.31

ANTENNA POLARITY & TEST DISTANCE: VERTICAL AT 3 M

NO.	FREQ. (MHz)	EMISSION LEVEL (dBuV/m)	LIMIT (dBuV/m)	MARGIN (dB)	ANTENNA HEIGHT (m)	TABLE ANGLE (Degree)	RAW VALUE (dBuV)	CORRECTION FACTOR (dB/m)
1	4824.00	40.2 PK	74.0	-33.8	1.00 V	321	37.89	2.31
2	4824.00	30.2 AV	54.0	-23.8	1.00 V	321	27.89	2.31

REMARKS:

- 1. Emission Level(dBuV/m) = Raw Value(dBuV) + Correction Factor(dB/m)
- 2. Correction Factor(dB/m) = Antenna Factor(dB/m) + Cable Factor(dB) – Pre-Amplifier Factor(dB)
- 3. The other emission levels were very low against the limit.
- 4. Margin value = Emission Level – Limit value

Antenna 1

CHANNEL	TX Channel 6	DETECTOR FUNCTION	Peak (PK)
FREQUENCY RANGE	1GHz ~ 25GHz		Average (AV)

ANTENNA POLARITY & TEST DISTANCE: HORIZONTAL AT 3 M

NO.	FREQ. (MHz)	EMISSION LEVEL (dBuV/m)	LIMIT (dBuV/m)	MARGIN (dB)	ANTENNA HEIGHT (m)	TABLE ANGLE (Degree)	RAW VALUE (dBuV)	CORRECTION FACTOR (dB/m)
1	4874.00	43.3 PK	74.0	-30.7	1.35 H	247	40.89	2.41
2	4874.00	33.2 AV	54.0	-20.8	1.35 H	247	30.79	2.41
3	7311.00	44.8 PK	74.0	-29.2	1.44 H	269	35.86	8.94
4	7311.00	35.1 AV	54.0	-18.9	1.44 H	269	26.16	8.94

ANTENNA POLARITY & TEST DISTANCE: VERTICAL AT 3 M

NO.	FREQ. (MHz)	EMISSION LEVEL (dBuV/m)	LIMIT (dBuV/m)	MARGIN (dB)	ANTENNA HEIGHT (m)	TABLE ANGLE (Degree)	RAW VALUE (dBuV)	CORRECTION FACTOR (dB/m)
1	4874.00	43.5 PK	74.0	-30.5	1.10 V	335	41.09	2.41
2	4874.00	33.4 AV	54.0	-20.6	1.10 V	335	30.99	2.41
3	7311.00	44.4 PK	74.0	-29.6	2.39 V	318	35.46	8.94
4	7311.00	34.5 AV	54.0	-19.5	2.39 V	318	25.56	8.94

REMARKS:

1. Emission Level(dBuV/m) = Raw Value(dBuV) + Correction Factor(dB/m)
2. Correction Factor(dB/m) = Antenna Factor(dB/m) + Cable Factor(dB) – Pre-Amplifier Factor(dB)
3. The other emission levels were very low against the limit.
4. Margin value = Emission Level – Limit value

Antenna 1

CHANNEL	TX Channel 11	DETECTOR FUNCTION	Peak (PK)
FREQUENCY RANGE	1GHz ~ 25GHz		Average (AV)

ANTENNA POLARITY & TEST DISTANCE: HORIZONTAL AT 3 M

NO.	FREQ. (MHz)	EMISSION LEVEL (dBuV/m)	LIMIT (dBuV/m)	MARGIN (dB)	ANTENNA HEIGHT (m)	TABLE ANGLE (Degree)	RAW VALUE (dBuV)	CORRECTION FACTOR (dB/m)
1	4924.00	40.2 PK	74.0	-33.8	1.33 H	245	37.70	2.50
2	4924.00	30.2 AV	54.0	-23.8	1.33 H	245	27.70	2.50
3	7386.00	44.6 PK	74.0	-29.4	1.39 H	260	35.26	9.34
4	7386.00	35.0 AV	54.0	-19.0	1.39 H	260	25.66	9.34

ANTENNA POLARITY & TEST DISTANCE: VERTICAL AT 3 M

NO.	FREQ. (MHz)	EMISSION LEVEL (dBuV/m)	LIMIT (dBuV/m)	MARGIN (dB)	ANTENNA HEIGHT (m)	TABLE ANGLE (Degree)	RAW VALUE (dBuV)	CORRECTION FACTOR (dB/m)
1	4924.00	40.2 PK	74.0	-33.8	1.06 V	319	37.70	2.50
2	4924.00	30.2 AV	54.0	-23.8	1.06 V	319	27.70	2.50
3	7386.00	45.5 PK	74.0	-28.5	2.34 V	303	36.16	9.34
4	7386.00	35.7 AV	54.0	-18.3	2.34 V	303	26.36	9.34

REMARKS:

1. Emission Level(dBuV/m) = Raw Value(dBuV) + Correction Factor(dB/m)
2. Correction Factor(dB/m) = Antenna Factor(dB/m) + Cable Factor(dB) – Pre-Amplifier Factor(dB)
3. The other emission levels were very low against the limit.
4. Margin value = Emission Level – Limit value

Antenna 1

802.11n (20MHz)

CHANNEL	TX Channel 1	DETECTOR FUNCTION	Peak (PK)
FREQUENCY RANGE	1GHz ~ 25GHz		Average (AV)

ANTENNA POLARITY & TEST DISTANCE: HORIZONTAL AT 3 M

NO.	FREQ. (MHz)	EMISSION LEVEL (dBuV/m)	LIMIT (dBuV/m)	MARGIN (dB)	ANTENNA HEIGHT (m)	TABLE ANGLE (Degree)	RAW VALUE (dBuV)	CORRECTION FACTOR (dB/m)
1	4824.00	39.8 PK	74.0	-34.2	1.34 H	244	37.49	2.31
2	4824.00	29.9 AV	54.0	-24.1	1.34 H	244	27.59	2.31

ANTENNA POLARITY & TEST DISTANCE: VERTICAL AT 3 M

NO.	FREQ. (MHz)	EMISSION LEVEL (dBuV/m)	LIMIT (dBuV/m)	MARGIN (dB)	ANTENNA HEIGHT (m)	TABLE ANGLE (Degree)	RAW VALUE (dBuV)	CORRECTION FACTOR (dB/m)
1	4824.00	39.8 PK	74.0	-34.2	1.00 V	316	37.49	2.31
2	4824.00	30.0 AV	54.0	-24.0	1.00 V	316	27.69	2.31

REMARKS:

1. Emission Level(dBuV/m) = Raw Value(dBuV) + Correction Factor(dB/m)
2. Correction Factor(dB/m) = Antenna Factor(dB/m) + Cable Factor(dB) – Pre-Amplifier Factor(dB)
3. The other emission levels were very low against the limit.
4. Margin value = Emission Level – Limit value

Antenna 1

CHANNEL	TX Channel 6	DETECTOR FUNCTION	Peak (PK)
FREQUENCY RANGE	1GHz ~ 25GHz		Average (AV)

ANTENNA POLARITY & TEST DISTANCE: HORIZONTAL AT 3 M

NO.	FREQ. (MHz)	EMISSION LEVEL (dBuV/m)	LIMIT (dBuV/m)	MARGIN (dB)	ANTENNA HEIGHT (m)	TABLE ANGLE (Degree)	RAW VALUE (dBuV)	CORRECTION FACTOR (dB/m)
1	4874.00	42.9 PK	74.0	-31.1	1.39 H	247	40.49	2.41
2	4874.00	33.0 AV	54.0	-21.0	1.39 H	247	30.59	2.41
3	7311.00	44.8 PK	74.0	-29.2	1.39 H	283	35.86	8.94
4	7311.00	34.9 AV	54.0	-19.1	1.39 H	283	25.96	8.94

ANTENNA POLARITY & TEST DISTANCE: VERTICAL AT 3 M

NO.	FREQ. (MHz)	EMISSION LEVEL (dBuV/m)	LIMIT (dBuV/m)	MARGIN (dB)	ANTENNA HEIGHT (m)	TABLE ANGLE (Degree)	RAW VALUE (dBuV)	CORRECTION FACTOR (dB/m)
1	4874.00	43.6 PK	74.0	-30.4	1.02 V	318	41.19	2.41
2	4874.00	33.4 AV	54.0	-20.6	1.02 V	318	30.99	2.41
3	7311.00	44.7 PK	74.0	-29.3	2.34 V	291	35.76	8.94
4	7311.00	34.7 AV	54.0	-19.3	2.34 V	291	25.76	8.94

REMARKS:

1. Emission Level(dBuV/m) = Raw Value(dBuV) + Correction Factor(dB/m)
2. Correction Factor(dB/m) = Antenna Factor(dB/m) + Cable Factor(dB) – Pre-Amplifier Factor(dB)
3. The other emission levels were very low against the limit.
4. Margin value = Emission Level – Limit value

Antenna 1

CHANNEL	TX Channel 11	DETECTOR FUNCTION	Peak (PK)
FREQUENCY RANGE	1GHz ~ 25GHz		Average (AV)

ANTENNA POLARITY & TEST DISTANCE: HORIZONTAL AT 3 M

NO.	FREQ. (MHz)	EMISSION LEVEL (dBuV/m)	LIMIT (dBuV/m)	MARGIN (dB)	ANTENNA HEIGHT (m)	TABLE ANGLE (Degree)	RAW VALUE (dBuV)	CORRECTION FACTOR (dB/m)
1	4924.00	39.9 PK	74.0	-34.1	1.36 H	260	37.40	2.50
2	4924.00	29.9 AV	54.0	-24.1	1.36 H	260	27.40	2.50
3	7386.00	44.4 PK	74.0	-29.6	1.39 H	257	35.06	9.34
4	7386.00	35.1 AV	54.0	-18.9	1.39 H	257	25.76	9.34

ANTENNA POLARITY & TEST DISTANCE: VERTICAL AT 3 M

NO.	FREQ. (MHz)	EMISSION LEVEL (dBuV/m)	LIMIT (dBuV/m)	MARGIN (dB)	ANTENNA HEIGHT (m)	TABLE ANGLE (Degree)	RAW VALUE (dBuV)	CORRECTION FACTOR (dB/m)
1	4924.00	40.4 PK	74.0	-33.6	1.01 V	324	37.90	2.50
2	4924.00	30.5 AV	54.0	-23.5	1.01 V	324	28.00	2.50
3	7386.00	45.1 PK	74.0	-28.9	2.37 V	299	35.76	9.34
4	7386.00	35.4 AV	54.0	-18.6	2.37 V	299	26.06	9.34

REMARKS:

1. Emission Level(dBuV/m) = Raw Value(dBuV) + Correction Factor(dB/m)
2. Correction Factor(dB/m) = Antenna Factor(dB/m) + Cable Factor(dB) – Pre-Amplifier Factor(dB)
3. The other emission levels were very low against the limit.
4. Margin value = Emission Level – Limit value

Antenna 1
802.11n (40MHz)

CHANNEL	TX Channel 3	DETECTOR FUNCTION	Peak (PK)
FREQUENCY RANGE	1GHz ~ 25GHz		Average (AV)

ANTENNA POLARITY & TEST DISTANCE: HORIZONTAL AT 3 M

NO.	FREQ. (MHz)	EMISSION LEVEL (dBuV/m)	LIMIT (dBuV/m)	MARGIN (dB)	ANTENNA HEIGHT (m)	TABLE ANGLE (Degree)	RAW VALUE (dBuV)	CORRECTION FACTOR (dB/m)
1	4844.00	40.5 PK	74.0	-33.5	1.32 H	231	38.14	2.36
2	4844.00	30.5 AV	54.0	-23.5	1.32 H	231	28.14	2.36
3	7266.00	45.0 PK	74.0	-29.0	1.33 H	268	36.18	8.82
4	7266.00	35.3 AV	54.0	-18.7	1.33 H	268	26.48	8.82

ANTENNA POLARITY & TEST DISTANCE: VERTICAL AT 3 M

NO.	FREQ. (MHz)	EMISSION LEVEL (dBuV/m)	LIMIT (dBuV/m)	MARGIN (dB)	ANTENNA HEIGHT (m)	TABLE ANGLE (Degree)	RAW VALUE (dBuV)	CORRECTION FACTOR (dB/m)
1	4844.00	40.0 PK	74.0	-34.0	1.02 V	328	37.64	2.36
2	4844.00	30.0 AV	54.0	-24.0	1.02 V	328	27.64	2.36
3	7266.00	45.1 PK	74.0	-28.9	2.33 V	311	36.28	8.82
4	7266.00	35.4 AV	54.0	-18.6	2.33 V	311	26.58	8.82

REMARKS:

1. Emission Level(dBuV/m) = Raw Value(dBuV) + Correction Factor(dB/m)
2. Correction Factor(dB/m) = Antenna Factor(dB/m) + Cable Factor(dB) – Pre-Amplifier Factor(dB)
3. The other emission levels were very low against the limit.
4. Margin value = Emission Level – Limit value

Antenna 1

CHANNEL	TX Channel 6	DETECTOR FUNCTION	Peak (PK)
FREQUENCY RANGE	1GHz ~ 25GHz		Average (AV)

ANTENNA POLARITY & TEST DISTANCE: HORIZONTAL AT 3 M

NO.	FREQ. (MHz)	EMISSION LEVEL (dBuV/m)	LIMIT (dBuV/m)	MARGIN (dB)	ANTENNA HEIGHT (m)	TABLE ANGLE (Degree)	RAW VALUE (dBuV)	CORRECTION FACTOR (dB/m)
1	4874.00	40.2 PK	74.0	-33.8	1.31 H	254	37.79	2.41
2	4874.00	30.5 AV	54.0	-23.5	1.31 H	254	28.09	2.41
3	7311.00	44.1 PK	74.0	-29.9	1.43 H	247	35.16	8.94
4	7311.00	34.6 AV	54.0	-19.4	1.43 H	247	25.66	8.94

ANTENNA POLARITY & TEST DISTANCE: VERTICAL AT 3 M

NO.	FREQ. (MHz)	EMISSION LEVEL (dBuV/m)	LIMIT (dBuV/m)	MARGIN (dB)	ANTENNA HEIGHT (m)	TABLE ANGLE (Degree)	RAW VALUE (dBuV)	CORRECTION FACTOR (dB/m)
1	4874.00	39.7 PK	74.0	-34.3	1.04 V	320	37.29	2.41
2	4874.00	29.9 AV	54.0	-24.1	1.04 V	320	27.49	2.41
3	7311.00	45.1 PK	74.0	-28.9	2.37 V	298	36.16	8.94
4	7311.00	35.6 AV	54.0	-18.4	2.37 V	298	26.66	8.94

REMARKS:

1. Emission Level(dBuV/m) = Raw Value(dBuV) + Correction Factor(dB/m)
2. Correction Factor(dB/m) = Antenna Factor(dB/m) + Cable Factor(dB) – Pre-Amplifier Factor(dB)
3. The other emission levels were very low against the limit.
4. Margin value = Emission Level – Limit value

Antenna 1

CHANNEL	TX Channel 9	DETECTOR FUNCTION	Peak (PK)
FREQUENCY RANGE	1GHz ~ 25GHz		Average (AV)

ANTENNA POLARITY & TEST DISTANCE: HORIZONTAL AT 3 M

NO.	FREQ. (MHz)	EMISSION LEVEL (dBuV/m)	LIMIT (dBuV/m)	MARGIN (dB)	ANTENNA HEIGHT (m)	TABLE ANGLE (Degree)	RAW VALUE (dBuV)	CORRECTION FACTOR (dB/m)
1	4904.00	39.9 PK	74.0	-34.1	1.30 H	251	37.43	2.47
2	4904.00	30.0 AV	54.0	-24.0	1.30 H	251	27.53	2.47
3	7356.00	45.2 PK	74.0	-28.8	1.42 H	267	36.02	9.18
4	7356.00	35.3 AV	54.0	-18.7	1.42 H	267	26.12	9.18

ANTENNA POLARITY & TEST DISTANCE: VERTICAL AT 3 M

NO.	FREQ. (MHz)	EMISSION LEVEL (dBuV/m)	LIMIT (dBuV/m)	MARGIN (dB)	ANTENNA HEIGHT (m)	TABLE ANGLE (Degree)	RAW VALUE (dBuV)	CORRECTION FACTOR (dB/m)
1	4904.00	39.6 PK	74.0	-34.4	1.04 V	330	37.13	2.47
2	4904.00	29.8 AV	54.0	-24.2	1.04 V	330	27.33	2.47
3	7356.00	45.6 PK	74.0	-28.4	2.31 V	287	36.42	9.18
4	7356.00	35.8 AV	54.0	-18.2	2.31 V	287	26.62	9.18

REMARKS:

1. Emission Level(dBuV/m) = Raw Value(dBuV) + Correction Factor(dB/m)
2. Correction Factor(dB/m) = Antenna Factor(dB/m) + Cable Factor(dB) – Pre-Amplifier Factor(dB)
3. The other emission levels were very low against the limit.
4. Margin value = Emission Level – Limit value

Antenna 2
802.11b

CHANNEL	TX Channel 1	DETECTOR FUNCTION	Peak (PK)
FREQUENCY RANGE	1GHz ~ 25GHz		Average (AV)

ANTENNA POLARITY & TEST DISTANCE: HORIZONTAL AT 3 M

NO.	FREQ. (MHz)	EMISSION LEVEL (dBuV/m)	LIMIT (dBuV/m)	MARGIN (dB)	ANTENNA HEIGHT (m)	TABLE ANGLE (Degree)	RAW VALUE (dBuV)	CORRECTION FACTOR (dB/m)
1	4824.00	53.8 PK	74.0	-20.2	1.00 H	256	51.49	2.31
2	4824.00	51.4 AV	54.0	-2.6	1.00 H	256	49.09	2.31

ANTENNA POLARITY & TEST DISTANCE: VERTICAL AT 3 M

NO.	FREQ. (MHz)	EMISSION LEVEL (dBuV/m)	LIMIT (dBuV/m)	MARGIN (dB)	ANTENNA HEIGHT (m)	TABLE ANGLE (Degree)	RAW VALUE (dBuV)	CORRECTION FACTOR (dB/m)
1	4824.00	51.9 PK	74.0	-22.1	1.02 V	343	49.59	2.31
2	4824.00	49.3 AV	54.0	-4.7	1.02 V	343	46.99	2.31

REMARKS:

1. Emission Level(dBuV/m) = Raw Value(dBuV) + Correction Factor(dB/m)
2. Correction Factor(dB/m) = Antenna Factor(dB/m) + Cable Factor(dB) – Pre-Amplifier Factor(dB)
3. The other emission levels were very low against the limit.
4. Margin value = Emission Level – Limit value

Antenna 2

CHANNEL	TX Channel 6	DETECTOR FUNCTION	Peak (PK)
FREQUENCY RANGE	1GHz ~ 25GHz		Average (AV)

ANTENNA POLARITY & TEST DISTANCE: HORIZONTAL AT 3 M

NO.	FREQ. (MHz)	EMISSION LEVEL (dBuV/m)	LIMIT (dBuV/m)	MARGIN (dB)	ANTENNA HEIGHT (m)	TABLE ANGLE (Degree)	RAW VALUE (dBuV)	CORRECTION FACTOR (dB/m)
1	4874.00	53.5 PK	74.0	-20.5	1.00 H	256	51.09	2.41
2	4874.00	51.7 AV	54.0	-2.3	1.00 H	256	49.29	2.41
3	7311.00	52.2 PK	74.0	-21.8	1.04 H	113	43.26	8.94
4	7311.00	47.4 AV	54.0	-6.6	1.04 H	113	38.46	8.94

ANTENNA POLARITY & TEST DISTANCE: VERTICAL AT 3 M

NO.	FREQ. (MHz)	EMISSION LEVEL (dBuV/m)	LIMIT (dBuV/m)	MARGIN (dB)	ANTENNA HEIGHT (m)	TABLE ANGLE (Degree)	RAW VALUE (dBuV)	CORRECTION FACTOR (dB/m)
1	4874.00	50.8 PK	74.0	-23.2	2.06 V	325	48.39	2.41
2	4874.00	48.3 AV	54.0	-5.7	2.06 V	325	45.89	2.41
3	7311.00	57.2 PK	74.0	-16.8	2.07 V	323	48.26	8.94
4	7311.00	53.7 AV	54.0	-0.3	2.07 V	323	44.76	8.94

REMARKS:

1. Emission Level(dBuV/m) = Raw Value(dBuV) + Correction Factor(dB/m)
2. Correction Factor(dB/m) = Antenna Factor(dB/m) + Cable Factor(dB) – Pre-Amplifier Factor(dB)
3. The other emission levels were very low against the limit.
4. Margin value = Emission Level – Limit value

Antenna 2

CHANNEL	TX Channel 11	DETECTOR FUNCTION	Peak (PK)
FREQUENCY RANGE	1GHz ~ 25GHz		Average (AV)

ANTENNA POLARITY & TEST DISTANCE: HORIZONTAL AT 3 M

NO.	FREQ. (MHz)	EMISSION LEVEL (dBuV/m)	LIMIT (dBuV/m)	MARGIN (dB)	ANTENNA HEIGHT (m)	TABLE ANGLE (Degree)	RAW VALUE (dBuV)	CORRECTION FACTOR (dB/m)
1	4924.00	53.7 PK	74.0	-20.3	1.02 H	242	51.20	2.50
2	4924.00	51.7 AV	54.0	-2.3	1.02 H	242	49.20	2.50
3	7386.00	52.0 PK	74.0	-22.0	1.03 H	126	42.66	9.34
4	7386.00	47.4 AV	54.0	-6.6	1.03 H	126	38.06	9.34

ANTENNA POLARITY & TEST DISTANCE: VERTICAL AT 3 M

NO.	FREQ. (MHz)	EMISSION LEVEL (dBuV/m)	LIMIT (dBuV/m)	MARGIN (dB)	ANTENNA HEIGHT (m)	TABLE ANGLE (Degree)	RAW VALUE (dBuV)	CORRECTION FACTOR (dB/m)
1	4924.00	52.2 PK	74.0	-21.8	1.03 V	350	49.70	2.50
2	4924.00	49.3 AV	54.0	-4.7	1.03 V	350	46.80	2.50
3	7386.00	52.9 PK	74.0	-21.1	2.07 V	331	43.56	9.34
4	7386.00	48.5 AV	54.0	-5.5	2.07 V	331	39.16	9.34

REMARKS:

1. Emission Level(dBuV/m) = Raw Value(dBuV) + Correction Factor(dB/m)
2. Correction Factor(dB/m) = Antenna Factor(dB/m) + Cable Factor(dB) – Pre-Amplifier Factor(dB)
3. The other emission levels were very low against the limit.
4. Margin value = Emission Level – Limit value



Antenna 2

802.11g

CHANNEL	TX Channel 1	DETECTOR FUNCTION	Peak (PK)
FREQUENCY RANGE	1GHz ~ 25GHz		Average (AV)

ANTENNA POLARITY & TEST DISTANCE: HORIZONTAL AT 3 M

NO.	FREQ. (MHz)	EMISSION LEVEL (dBuV/m)	LIMIT (dBuV/m)	MARGIN (dB)	ANTENNA HEIGHT (m)	TABLE ANGLE (Degree)	RAW VALUE (dBuV)	CORRECTION FACTOR (dB/m)
1	4824.00	40.3 PK	74.0	-33.7	1.00 H	258	37.99	2.31
2	4824.00	32.2 AV	54.0	-21.8	1.00 H	258	29.89	2.31

ANTENNA POLARITY & TEST DISTANCE: VERTICAL AT 3 M

NO.	FREQ. (MHz)	EMISSION LEVEL (dBuV/m)	LIMIT (dBuV/m)	MARGIN (dB)	ANTENNA HEIGHT (m)	TABLE ANGLE (Degree)	RAW VALUE (dBuV)	CORRECTION FACTOR (dB/m)
1	4824.00	40.4 PK	74.0	-33.6	1.07 V	349	38.09	2.31
2	4824.00	30.1 AV	54.0	-23.9	1.07 V	349	27.79	2.31

REMARKS:

- 1. Emission Level(dBuV/m) = Raw Value(dBuV) + Correction Factor(dB/m)
- 2. Correction Factor(dB/m) = Antenna Factor(dB/m) + Cable Factor(dB) – Pre-Amplifier Factor(dB)
- 3. The other emission levels were very low against the limit.
- 4. Margin value = Emission Level – Limit value

Antenna 2

CHANNEL	TX Channel 6	DETECTOR FUNCTION	Peak (PK)
FREQUENCY RANGE	1GHz ~ 25GHz		Average (AV)

ANTENNA POLARITY & TEST DISTANCE: HORIZONTAL AT 3 M

NO.	FREQ. (MHz)	EMISSION LEVEL (dBuV/m)	LIMIT (dBuV/m)	MARGIN (dB)	ANTENNA HEIGHT (m)	TABLE ANGLE (Degree)	RAW VALUE (dBuV)	CORRECTION FACTOR (dB/m)
1	4874.00	45.9 PK	74.0	-28.1	1.00 H	258	43.49	2.41
2	4874.00	34.7 AV	54.0	-19.3	1.00 H	258	32.29	2.41
3	7311.00	44.5 PK	74.0	-29.5	1.02 H	111	35.56	8.94
4	7311.00	34.4 AV	54.0	-19.6	1.02 H	111	25.46	8.94

ANTENNA POLARITY & TEST DISTANCE: VERTICAL AT 3 M

NO.	FREQ. (MHz)	EMISSION LEVEL (dBuV/m)	LIMIT (dBuV/m)	MARGIN (dB)	ANTENNA HEIGHT (m)	TABLE ANGLE (Degree)	RAW VALUE (dBuV)	CORRECTION FACTOR (dB/m)
1	4874.00	43.5 PK	74.0	-30.5	1.01 V	357	41.09	2.41
2	4874.00	33.3 AV	54.0	-20.7	1.01 V	357	30.89	2.41
3	7311.00	44.3 PK	74.0	-29.7	2.11 V	330	35.36	8.94
4	7311.00	34.1 AV	54.0	-19.9	2.11 V	330	25.16	8.94

REMARKS:

1. Emission Level(dBuV/m) = Raw Value(dBuV) + Correction Factor(dB/m)
2. Correction Factor(dB/m) = Antenna Factor(dB/m) + Cable Factor(dB) – Pre-Amplifier Factor(dB)
3. The other emission levels were very low against the limit.
4. Margin value = Emission Level – Limit value

Antenna 2

CHANNEL	TX Channel 11	DETECTOR FUNCTION	Peak (PK)
FREQUENCY RANGE	1GHz ~ 25GHz		Average (AV)

ANTENNA POLARITY & TEST DISTANCE: HORIZONTAL AT 3 M								
NO.	FREQ. (MHz)	EMISSION LEVEL (dBuV/m)	LIMIT (dBuV/m)	MARGIN (dB)	ANTENNA HEIGHT (m)	TABLE ANGLE (Degree)	RAW VALUE (dBuV)	CORRECTION FACTOR (dB/m)
1	4924.00	40.2 PK	74.0	-33.8	1.01 H	247	37.70	2.50
2	4924.00	32.0 AV	54.0	-22.0	1.01 H	247	29.50	2.50
3	7386.00	45.3 PK	74.0	-28.7	1.06 H	123	35.96	9.34
4	7386.00	35.6 AV	54.0	-18.4	1.06 H	123	26.26	9.34

ANTENNA POLARITY & TEST DISTANCE: VERTICAL AT 3 M								
NO.	FREQ. (MHz)	EMISSION LEVEL (dBuV/m)	LIMIT (dBuV/m)	MARGIN (dB)	ANTENNA HEIGHT (m)	TABLE ANGLE (Degree)	RAW VALUE (dBuV)	CORRECTION FACTOR (dB/m)
1	4924.00	39.8 PK	74.0	-34.2	1.01 V	353	37.30	2.50
2	4924.00	30.1 AV	54.0	-23.9	1.01 V	353	27.60	2.50
3	7386.00	45.6 PK	74.0	-28.4	2.03 V	326	36.26	9.34
4	7386.00	35.9 AV	54.0	-18.1	2.03 V	326	26.56	9.34

REMARKS:

1. Emission Level(dBuV/m) = Raw Value(dBuV) + Correction Factor(dB/m)
2. Correction Factor(dB/m) = Antenna Factor(dB/m) + Cable Factor(dB) – Pre-Amplifier Factor(dB)
3. The other emission levels were very low against the limit.
4. Margin value = Emission Level – Limit value

Antenna 2
802.11n (20MHz)

CHANNEL	TX Channel 1	DETECTOR FUNCTION	Peak (PK)
FREQUENCY RANGE	1GHz ~ 25GHz		Average (AV)

ANTENNA POLARITY & TEST DISTANCE: HORIZONTAL AT 3 M

NO.	FREQ. (MHz)	EMISSION LEVEL (dBuV/m)	LIMIT (dBuV/m)	MARGIN (dB)	ANTENNA HEIGHT (m)	TABLE ANGLE (Degree)	RAW VALUE (dBuV)	CORRECTION FACTOR (dB/m)
1	4824.00	40.1 PK	74.0	-33.9	1.01 H	237	37.79	2.31
2	4824.00	31.8 AV	54.0	-22.2	1.01 H	237	29.49	2.31

ANTENNA POLARITY & TEST DISTANCE: VERTICAL AT 3 M

NO.	FREQ. (MHz)	EMISSION LEVEL (dBuV/m)	LIMIT (dBuV/m)	MARGIN (dB)	ANTENNA HEIGHT (m)	TABLE ANGLE (Degree)	RAW VALUE (dBuV)	CORRECTION FACTOR (dB/m)
1	4824.00	40.0 PK	74.0	-34.0	1.04 V	360	37.69	2.31
2	4824.00	30.4 AV	54.0	-23.6	1.04 V	360	28.09	2.31

REMARKS:

1. Emission Level(dBuV/m) = Raw Value(dBuV) + Correction Factor(dB/m)
2. Correction Factor(dB/m) = Antenna Factor(dB/m) + Cable Factor(dB) – Pre-Amplifier Factor(dB)
3. The other emission levels were very low against the limit.
4. Margin value = Emission Level – Limit value

Antenna 2

CHANNEL	TX Channel 6	DETECTOR FUNCTION	Peak (PK)
FREQUENCY RANGE	1GHz ~ 25GHz		Average (AV)

ANTENNA POLARITY & TEST DISTANCE: HORIZONTAL AT 3 M

NO.	FREQ. (MHz)	EMISSION LEVEL (dBuV/m)	LIMIT (dBuV/m)	MARGIN (dB)	ANTENNA HEIGHT (m)	TABLE ANGLE (Degree)	RAW VALUE (dBuV)	CORRECTION FACTOR (dB/m)
1	4874.00	44.7 PK	74.0	-29.3	1.00 H	262	42.29	2.41
2	4874.00	34.9 AV	54.0	-19.1	1.00 H	262	32.49	2.41
3	7311.00	44.5 PK	74.0	-29.5	1.00 H	97	35.56	8.94
4	7311.00	34.4 AV	54.0	-19.6	1.00 H	97	25.46	8.94

ANTENNA POLARITY & TEST DISTANCE: VERTICAL AT 3 M

NO.	FREQ. (MHz)	EMISSION LEVEL (dBuV/m)	LIMIT (dBuV/m)	MARGIN (dB)	ANTENNA HEIGHT (m)	TABLE ANGLE (Degree)	RAW VALUE (dBuV)	CORRECTION FACTOR (dB/m)
1	4874.00	43.7 PK	74.0	-30.3	1.04 V	360	41.29	2.41
2	4874.00	33.6 AV	54.0	-20.4	1.04 V	360	31.19	2.41
3	7311.00	44.3 PK	74.0	-29.7	2.11 V	303	35.36	8.94
4	7311.00	34.4 AV	54.0	-19.6	2.11 V	303	25.46	8.94

REMARKS:

1. Emission Level(dBuV/m) = Raw Value(dBuV) + Correction Factor(dB/m)
2. Correction Factor(dB/m) = Antenna Factor(dB/m) + Cable Factor(dB) – Pre-Amplifier Factor(dB)
3. The other emission levels were very low against the limit.
4. Margin value = Emission Level – Limit value

Antenna 2

CHANNEL	TX Channel 11	DETECTOR FUNCTION	Peak (PK)
FREQUENCY RANGE	1GHz ~ 25GHz		Average (AV)

ANTENNA POLARITY & TEST DISTANCE: HORIZONTAL AT 3 M

NO.	FREQ. (MHz)	EMISSION LEVEL (dBuV/m)	LIMIT (dBuV/m)	MARGIN (dB)	ANTENNA HEIGHT (m)	TABLE ANGLE (Degree)	RAW VALUE (dBuV)	CORRECTION FACTOR (dB/m)
1	4924.00	40.2 PK	74.0	-33.8	1.04 H	236	37.70	2.50
2	4924.00	31.9 AV	54.0	-22.1	1.04 H	236	29.40	2.50
3	7386.00	45.9 PK	74.0	-28.1	1.02 H	121	36.56	9.34
4	7386.00	36.0 AV	54.0	-18.0	1.02 H	121	26.66	9.34

ANTENNA POLARITY & TEST DISTANCE: VERTICAL AT 3 M

NO.	FREQ. (MHz)	EMISSION LEVEL (dBuV/m)	LIMIT (dBuV/m)	MARGIN (dB)	ANTENNA HEIGHT (m)	TABLE ANGLE (Degree)	RAW VALUE (dBuV)	CORRECTION FACTOR (dB/m)
1	4924.00	39.1 PK	74.0	-34.9	1.03 V	360	36.60	2.50
2	4924.00	29.7 AV	54.0	-24.3	1.03 V	360	27.20	2.50
3	7386.00	45.3 PK	74.0	-28.7	2.02 V	315	35.96	9.34
4	7386.00	35.7 AV	54.0	-18.3	2.02 V	315	26.36	9.34

REMARKS:

1. Emission Level(dBuV/m) = Raw Value(dBuV) + Correction Factor(dB/m)
2. Correction Factor(dB/m) = Antenna Factor(dB/m) + Cable Factor(dB) – Pre-Amplifier Factor(dB)
3. The other emission levels were very low against the limit.
4. Margin value = Emission Level – Limit value

Antenna 2
802.11n (40MHz)

CHANNEL	TX Channel 3	DETECTOR FUNCTION	Peak (PK)
FREQUENCY RANGE	1GHz ~ 25GHz		Average (AV)

ANTENNA POLARITY & TEST DISTANCE: HORIZONTAL AT 3 M

NO.	FREQ. (MHz)	EMISSION LEVEL (dBuV/m)	LIMIT (dBuV/m)	MARGIN (dB)	ANTENNA HEIGHT (m)	TABLE ANGLE (Degree)	RAW VALUE (dBuV)	CORRECTION FACTOR (dB/m)
1	4844.00	39.9 PK	74.0	-34.1	1.04 H	242	37.54	2.36
2	4844.00	30.4 AV	54.0	-23.6	1.04 H	242	28.04	2.36
3	7266.00	45.9 PK	74.0	-28.1	1.06 H	111	37.08	8.82
4	7266.00	36.1 AV	54.0	-17.9	1.06 H	111	27.28	8.82

ANTENNA POLARITY & TEST DISTANCE: VERTICAL AT 3 M

NO.	FREQ. (MHz)	EMISSION LEVEL (dBuV/m)	LIMIT (dBuV/m)	MARGIN (dB)	ANTENNA HEIGHT (m)	TABLE ANGLE (Degree)	RAW VALUE (dBuV)	CORRECTION FACTOR (dB/m)
1	4844.00	39.8 PK	74.0	-34.2	1.05 V	344	37.44	2.36
2	4844.00	30.1 AV	54.0	-23.9	1.05 V	344	27.74	2.36
3	7266.00	45.9 PK	74.0	-28.1	2.06 V	311	37.08	8.82
4	7266.00	36.2 AV	54.0	-17.8	2.06 V	311	27.38	8.82

REMARKS:

1. Emission Level(dBuV/m) = Raw Value(dBuV) + Correction Factor(dB/m)
2. Correction Factor(dB/m) = Antenna Factor(dB/m) + Cable Factor(dB) – Pre-Amplifier Factor(dB)
3. The other emission levels were very low against the limit.
4. Margin value = Emission Level – Limit value

Antenna 2

CHANNEL	TX Channel 6	DETECTOR FUNCTION	Peak (PK)
FREQUENCY RANGE	1GHz ~ 25GHz		Average (AV)

ANTENNA POLARITY & TEST DISTANCE: HORIZONTAL AT 3 M

NO.	FREQ. (MHz)	EMISSION LEVEL (dBuV/m)	LIMIT (dBuV/m)	MARGIN (dB)	ANTENNA HEIGHT (m)	TABLE ANGLE (Degree)	RAW VALUE (dBuV)	CORRECTION FACTOR (dB/m)
1	4874.00	39.6 PK	74.0	-34.4	1.00 H	250	37.19	2.41
2	4874.00	29.9 AV	54.0	-24.1	1.00 H	250	27.49	2.41
3	7311.00	45.3 PK	74.0	-28.7	1.04 H	108	36.36	8.94
4	7311.00	35.7 AV	54.0	-18.3	1.04 H	108	26.76	8.94

ANTENNA POLARITY & TEST DISTANCE: VERTICAL AT 3 M

NO.	FREQ. (MHz)	EMISSION LEVEL (dBuV/m)	LIMIT (dBuV/m)	MARGIN (dB)	ANTENNA HEIGHT (m)	TABLE ANGLE (Degree)	RAW VALUE (dBuV)	CORRECTION FACTOR (dB/m)
1	4874.00	40.0 PK	74.0	-34.0	1.00 V	360	37.59	2.41
2	4874.00	30.2 AV	54.0	-23.8	1.00 V	360	27.79	2.41
3	7311.00	46.0 PK	74.0	-28.0	2.03 V	319	37.06	8.94
4	7311.00	36.1 AV	54.0	-17.9	2.03 V	319	27.16	8.94

REMARKS:

1. Emission Level(dBuV/m) = Raw Value(dBuV) + Correction Factor(dB/m)
2. Correction Factor(dB/m) = Antenna Factor(dB/m) + Cable Factor(dB) – Pre-Amplifier Factor(dB)
3. The other emission levels were very low against the limit.
4. Margin value = Emission Level – Limit value

Antenna 2

CHANNEL	TX Channel 9	DETECTOR FUNCTION	Peak (PK)
FREQUENCY RANGE	1GHz ~ 25GHz		Average (AV)

ANTENNA POLARITY & TEST DISTANCE: HORIZONTAL AT 3 M

NO.	FREQ. (MHz)	EMISSION LEVEL (dBuV/m)	LIMIT (dBuV/m)	MARGIN (dB)	ANTENNA HEIGHT (m)	TABLE ANGLE (Degree)	RAW VALUE (dBuV)	CORRECTION FACTOR (dB/m)
1	4904.00	39.4 PK	74.0	-34.6	1.00 H	260	36.93	2.47
2	4904.00	30.0 AV	54.0	-24.0	1.00 H	260	27.53	2.47
3	7356.00	45.1 PK	74.0	-28.9	1.07 H	116	35.92	9.18
4	7356.00	35.4 AV	54.0	-18.6	1.07 H	116	26.22	9.18

ANTENNA POLARITY & TEST DISTANCE: VERTICAL AT 3 M

NO.	FREQ. (MHz)	EMISSION LEVEL (dBuV/m)	LIMIT (dBuV/m)	MARGIN (dB)	ANTENNA HEIGHT (m)	TABLE ANGLE (Degree)	RAW VALUE (dBuV)	CORRECTION FACTOR (dB/m)
1	4904.00	39.2 PK	74.0	-34.8	1.01 V	338	36.73	2.47
2	4904.00	29.6 AV	54.0	-24.4	1.01 V	338	27.13	2.47
3	7356.00	46.0 PK	74.0	-28.0	2.03 V	335	36.82	9.18
4	7356.00	36.4 AV	54.0	-17.6	2.03 V	335	27.22	9.18

REMARKS:

1. Emission Level(dBuV/m) = Raw Value(dBuV) + Correction Factor(dB/m)
2. Correction Factor(dB/m) = Antenna Factor(dB/m) + Cable Factor(dB) – Pre-Amplifier Factor(dB)
3. The other emission levels were very low against the limit.
4. Margin value = Emission Level – Limit value

2TX

802.11g

CHANNEL	TX Channel 1	DETECTOR FUNCTION	Peak (PK)
FREQUENCY RANGE	1GHz ~ 25GHz		Average (AV)

ANTENNA POLARITY & TEST DISTANCE: HORIZONTAL AT 3 M

NO.	FREQ. (MHz)	EMISSION LEVEL (dBuV/m)	LIMIT (dBuV/m)	MARGIN (dB)	ANTENNA HEIGHT (m)	TABLE ANGLE (Degree)	RAW VALUE (dBuV)	CORRECTION FACTOR (dB/m)
1	4824.00	39.4 PK	74.0	-34.6	1.00 H	275	37.09	2.31
2	4824.00	30.3 AV	54.0	-23.7	1.00 H	275	27.99	2.31

ANTENNA POLARITY & TEST DISTANCE: VERTICAL AT 3 M

NO.	FREQ. (MHz)	EMISSION LEVEL (dBuV/m)	LIMIT (dBuV/m)	MARGIN (dB)	ANTENNA HEIGHT (m)	TABLE ANGLE (Degree)	RAW VALUE (dBuV)	CORRECTION FACTOR (dB/m)
1	4824.00	39.7 PK	74.0	-34.3	1.04 V	339	37.39	2.31
2	4824.00	30.1 AV	54.0	-23.9	1.04 V	339	27.79	2.31

REMARKS:

1. Emission Level(dBuV/m) = Raw Value(dBuV) + Correction Factor(dB/m)
2. Correction Factor(dB/m) = Antenna Factor(dB/m) + Cable Factor(dB) – Pre-Amplifier Factor(dB)
3. The other emission levels were very low against the limit.
4. Margin value = Emission Level – Limit value

CHANNEL	TX Channel 6	DETECTOR FUNCTION	Peak (PK)
FREQUENCY RANGE	1GHz ~ 25GHz		Average (AV)

ANTENNA POLARITY & TEST DISTANCE: HORIZONTAL AT 3 M

NO.	FREQ. (MHz)	EMISSION LEVEL (dBuV/m)	LIMIT (dBuV/m)	MARGIN (dB)	ANTENNA HEIGHT (m)	TABLE ANGLE (Degree)	RAW VALUE (dBuV)	CORRECTION FACTOR (dB/m)
1	4874.00	44.4 PK	74.0	-29.6	1.01 H	258	41.99	2.41
2	4874.00	33.6 AV	54.0	-20.4	1.01 H	258	31.19	2.41
3	7311.00	44.8 PK	74.0	-29.2	1.08 H	101	35.86	8.94
4	7311.00	34.7 AV	54.0	-19.3	1.08 H	101	25.76	8.94

ANTENNA POLARITY & TEST DISTANCE: VERTICAL AT 3 M

NO.	FREQ. (MHz)	EMISSION LEVEL (dBuV/m)	LIMIT (dBuV/m)	MARGIN (dB)	ANTENNA HEIGHT (m)	TABLE ANGLE (Degree)	RAW VALUE (dBuV)	CORRECTION FACTOR (dB/m)
1	4874.00	43.8 PK	74.0	-30.2	1.05 V	360	41.39	2.41
2	4874.00	33.4 AV	54.0	-20.6	1.05 V	360	30.99	2.41
3	7311.00	44.8 PK	74.0	-29.2	2.07 V	321	35.86	8.94
4	7311.00	34.4 AV	54.0	-19.6	2.07 V	321	25.46	8.94

REMARKS:

1. Emission Level(dBuV/m) = Raw Value(dBuV) + Correction Factor(dB/m)
2. Correction Factor(dB/m) = Antenna Factor(dB/m) + Cable Factor(dB) – Pre-Amplifier Factor(dB)
3. The other emission levels were very low against the limit.
4. Margin value = Emission Level – Limit value



CHANNEL	TX Channel 11	DETECTOR FUNCTION	Peak (PK)
FREQUENCY RANGE	1GHz ~ 25GHz		Average (AV)

ANTENNA POLARITY & TEST DISTANCE: HORIZONTAL AT 3 M

NO.	FREQ. (MHz)	EMISSION LEVEL (dBuV/m)	LIMIT (dBuV/m)	MARGIN (dB)	ANTENNA HEIGHT (m)	TABLE ANGLE (Degree)	RAW VALUE (dBuV)	CORRECTION FACTOR (dB/m)
1	4924.00	39.4 PK	74.0	-34.6	1.00 H	271	36.90	2.50
2	4924.00	29.7 AV	54.0	-24.3	1.00 H	271	27.20	2.50
3	7386.00	44.7 PK	74.0	-29.3	1.08 H	101	35.36	9.34
4	7386.00	35.2 AV	54.0	-18.8	1.08 H	101	25.86	9.34

ANTENNA POLARITY & TEST DISTANCE: VERTICAL AT 3 M

NO.	FREQ. (MHz)	EMISSION LEVEL (dBuV/m)	LIMIT (dBuV/m)	MARGIN (dB)	ANTENNA HEIGHT (m)	TABLE ANGLE (Degree)	RAW VALUE (dBuV)	CORRECTION FACTOR (dB/m)
1	4924.00	39.5 PK	74.0	-34.5	1.00 V	360	37.00	2.50
2	4924.00	30.1 AV	54.0	-23.9	1.00 V	360	27.60	2.50
3	7386.00	45.3 PK	74.0	-28.7	2.05 V	311	35.96	9.34
4	7386.00	35.7 AV	54.0	-18.3	2.05 V	311	26.36	9.34

REMARKS:

1. Emission Level(dBuV/m) = Raw Value(dBuV) + Correction Factor(dB/m)
2. Correction Factor(dB/m) = Antenna Factor(dB/m) + Cable Factor(dB) – Pre-Amplifier Factor(dB)
3. The other emission levels were very low against the limit.
4. Margin value = Emission Level – Limit value

802.11n (20MHz)

CHANNEL	TX Channel 1	DETECTOR FUNCTION	Peak (PK)
FREQUENCY RANGE	1GHz ~ 25GHz		Average (AV)

ANTENNA POLARITY & TEST DISTANCE: HORIZONTAL AT 3 M

NO.	FREQ. (MHz)	EMISSION LEVEL (dBuV/m)	LIMIT (dBuV/m)	MARGIN (dB)	ANTENNA HEIGHT (m)	TABLE ANGLE (Degree)	RAW VALUE (dBuV)	CORRECTION FACTOR (dB/m)
1	4824.00	39.5 PK	74.0	-34.5	1.00 H	267	37.19	2.31
2	4824.00	29.9 AV	54.0	-24.1	1.00 H	267	27.59	2.31

ANTENNA POLARITY & TEST DISTANCE: VERTICAL AT 3 M

NO.	FREQ. (MHz)	EMISSION LEVEL (dBuV/m)	LIMIT (dBuV/m)	MARGIN (dB)	ANTENNA HEIGHT (m)	TABLE ANGLE (Degree)	RAW VALUE (dBuV)	CORRECTION FACTOR (dB/m)
1	4824.00	40.1 PK	74.0	-33.9	1.06 V	346	37.79	2.31
2	4824.00	30.6 AV	54.0	-23.4	1.06 V	346	28.29	2.31

REMARKS:

1. Emission Level(dBuV/m) = Raw Value(dBuV) + Correction Factor(dB/m)
2. Correction Factor(dB/m) = Antenna Factor(dB/m) + Cable Factor(dB) – Pre-Amplifier Factor(dB)
3. The other emission levels were very low against the limit.
4. Margin value = Emission Level – Limit value



CHANNEL	TX Channel 6	DETECTOR FUNCTION	Peak (PK)
FREQUENCY RANGE	1GHz ~ 25GHz		Average (AV)

ANTENNA POLARITY & TEST DISTANCE: HORIZONTAL AT 3 M

NO.	FREQ. (MHz)	EMISSION LEVEL (dBuV/m)	LIMIT (dBuV/m)	MARGIN (dB)	ANTENNA HEIGHT (m)	TABLE ANGLE (Degree)	RAW VALUE (dBuV)	CORRECTION FACTOR (dB/m)
1	4874.00	44.1 PK	74.0	-29.9	1.00 H	248	41.69	2.41
2	4874.00	33.4 AV	54.0	-20.6	1.00 H	248	30.99	2.41
3	7311.00	44.5 PK	74.0	-29.5	1.05 H	112	35.56	8.94
4	7311.00	34.3 AV	54.0	-19.7	1.05 H	112	25.36	8.94

ANTENNA POLARITY & TEST DISTANCE: VERTICAL AT 3 M

NO.	FREQ. (MHz)	EMISSION LEVEL (dBuV/m)	LIMIT (dBuV/m)	MARGIN (dB)	ANTENNA HEIGHT (m)	TABLE ANGLE (Degree)	RAW VALUE (dBuV)	CORRECTION FACTOR (dB/m)
1	4874.00	43.2 PK	74.0	-30.8	1.00 V	360	40.79	2.41
2	4874.00	32.8 AV	54.0	-21.2	1.00 V	360	30.39	2.41
3	7311.00	44.2 PK	74.0	-29.8	2.07 V	328	35.26	8.94
4	7311.00	34.1 AV	54.0	-19.9	2.07 V	328	25.16	8.94

REMARKS:

1. Emission Level(dBuV/m) = Raw Value(dBuV) + Correction Factor(dB/m)
2. Correction Factor(dB/m) = Antenna Factor(dB/m) + Cable Factor(dB) – Pre-Amplifier Factor(dB)
3. The other emission levels were very low against the limit.
4. Margin value = Emission Level – Limit value



CHANNEL	TX Channel 11	DETECTOR FUNCTION	Peak (PK)
FREQUENCY RANGE	1GHz ~ 25GHz		Average (AV)

ANTENNA POLARITY & TEST DISTANCE: HORIZONTAL AT 3 M

NO.	FREQ. (MHz)	EMISSION LEVEL (dBuV/m)	LIMIT (dBuV/m)	MARGIN (dB)	ANTENNA HEIGHT (m)	TABLE ANGLE (Degree)	RAW VALUE (dBuV)	CORRECTION FACTOR (dB/m)
1	4924.00	39.6 PK	74.0	-34.4	1.00 H	275	37.10	2.50
2	4924.00	30.1 AV	54.0	-23.9	1.00 H	275	27.60	2.50
3	7386.00	45.3 PK	74.0	-28.7	1.12 H	110	35.96	9.34
4	7386.00	35.4 AV	54.0	-18.6	1.12 H	110	26.06	9.34

ANTENNA POLARITY & TEST DISTANCE: VERTICAL AT 3 M

NO.	FREQ. (MHz)	EMISSION LEVEL (dBuV/m)	LIMIT (dBuV/m)	MARGIN (dB)	ANTENNA HEIGHT (m)	TABLE ANGLE (Degree)	RAW VALUE (dBuV)	CORRECTION FACTOR (dB/m)
1	4924.00	40.1 PK	74.0	-33.9	1.00 V	359	37.60	2.50
2	4924.00	30.3 AV	54.0	-23.7	1.00 V	359	27.80	2.50
3	7386.00	45.8 PK	74.0	-28.2	1.97 V	315	36.46	9.34
4	7386.00	36.2 AV	54.0	-17.8	1.97 V	315	26.86	9.34

REMARKS:

1. Emission Level(dBuV/m) = Raw Value(dBuV) + Correction Factor(dB/m)
2. Correction Factor(dB/m) = Antenna Factor(dB/m) + Cable Factor(dB) – Pre-Amplifier Factor(dB)
3. The other emission levels were very low against the limit.
4. Margin value = Emission Level – Limit value

802.11n (40MHz)

CHANNEL	TX Channel 3	DETECTOR FUNCTION	Peak (PK)
FREQUENCY RANGE	1GHz ~ 25GHz		Average (AV)

ANTENNA POLARITY & TEST DISTANCE: HORIZONTAL AT 3 M

NO.	FREQ. (MHz)	EMISSION LEVEL (dBuV/m)	LIMIT (dBuV/m)	MARGIN (dB)	ANTENNA HEIGHT (m)	TABLE ANGLE (Degree)	RAW VALUE (dBuV)	CORRECTION FACTOR (dB/m)
1	4844.00	39.8 PK	74.0	-34.2	1.00 H	256	37.44	2.36
2	4844.00	30.3 AV	54.0	-23.7	1.00 H	256	27.94	2.36
3	7266.00	45.2 PK	74.0	-28.8	1.09 H	110	36.38	8.82
4	7266.00	35.5 AV	54.0	-18.5	1.09 H	110	26.68	8.82

ANTENNA POLARITY & TEST DISTANCE: VERTICAL AT 3 M

NO.	FREQ. (MHz)	EMISSION LEVEL (dBuV/m)	LIMIT (dBuV/m)	MARGIN (dB)	ANTENNA HEIGHT (m)	TABLE ANGLE (Degree)	RAW VALUE (dBuV)	CORRECTION FACTOR (dB/m)
1	4844.00	39.6 PK	74.0	-34.4	1.00 V	344	37.24	2.36
2	4844.00	30.1 AV	54.0	-23.9	1.00 V	344	27.74	2.36
3	7266.00	46.0 PK	74.0	-28.0	2.08 V	331	37.18	8.82
4	7266.00	36.1 AV	54.0	-17.9	2.08 V	331	27.28	8.82

REMARKS:

1. Emission Level(dBuV/m) = Raw Value(dBuV) + Correction Factor(dB/m)
2. Correction Factor(dB/m) = Antenna Factor(dB/m) + Cable Factor(dB) – Pre-Amplifier Factor(dB)
3. The other emission levels were very low against the limit.
4. Margin value = Emission Level – Limit value



CHANNEL	TX Channel 6	DETECTOR FUNCTION	Peak (PK)
FREQUENCY RANGE	1GHz ~ 25GHz		Average (AV)

ANTENNA POLARITY & TEST DISTANCE: HORIZONTAL AT 3 M

NO.	FREQ. (MHz)	EMISSION LEVEL (dBuV/m)	LIMIT (dBuV/m)	MARGIN (dB)	ANTENNA HEIGHT (m)	TABLE ANGLE (Degree)	RAW VALUE (dBuV)	CORRECTION FACTOR (dB/m)
1	4874.00	38.9 PK	74.0	-35.1	1.00 H	251	36.49	2.41
2	4874.00	29.5 AV	54.0	-24.5	1.00 H	251	27.09	2.41
3	7311.00	44.8 PK	74.0	-29.2	1.05 H	109	35.86	8.94
4	7311.00	35.3 AV	54.0	-18.7	1.05 H	109	26.36	8.94

ANTENNA POLARITY & TEST DISTANCE: VERTICAL AT 3 M

NO.	FREQ. (MHz)	EMISSION LEVEL (dBuV/m)	LIMIT (dBuV/m)	MARGIN (dB)	ANTENNA HEIGHT (m)	TABLE ANGLE (Degree)	RAW VALUE (dBuV)	CORRECTION FACTOR (dB/m)
1	4874.00	39.9 PK	74.0	-34.1	1.00 V	352	37.49	2.41
2	4874.00	30.4 AV	54.0	-23.6	1.00 V	352	27.99	2.41
3	7311.00	45.6 PK	74.0	-28.4	2.02 V	342	36.66	8.94
4	7311.00	35.7 AV	54.0	-18.3	2.02 V	342	26.76	8.94

REMARKS:

1. Emission Level(dBuV/m) = Raw Value(dBuV) + Correction Factor(dB/m)
2. Correction Factor(dB/m) = Antenna Factor(dB/m) + Cable Factor(dB) – Pre-Amplifier Factor(dB)
3. The other emission levels were very low against the limit.
4. Margin value = Emission Level – Limit value



CHANNEL	TX Channel 9	DETECTOR FUNCTION	Peak (PK)
FREQUENCY RANGE	1GHz ~ 25GHz		Average (AV)

ANTENNA POLARITY & TEST DISTANCE: HORIZONTAL AT 3 M

NO.	FREQ. (MHz)	EMISSION LEVEL (dBuV/m)	LIMIT (dBuV/m)	MARGIN (dB)	ANTENNA HEIGHT (m)	TABLE ANGLE (Degree)	RAW VALUE (dBuV)	CORRECTION FACTOR (dB/m)
1	4904.00	40.0 PK	74.0	-34.0	1.00 H	244	37.53	2.47
2	4904.00	30.4 AV	54.0	-23.6	1.00 H	244	27.93	2.47
3	7356.00	45.0 PK	74.0	-29.0	1.04 H	117	35.82	9.18
4	7356.00	35.6 AV	54.0	-18.4	1.04 H	117	26.42	9.18

ANTENNA POLARITY & TEST DISTANCE: VERTICAL AT 3 M

NO.	FREQ. (MHz)	EMISSION LEVEL (dBuV/m)	LIMIT (dBuV/m)	MARGIN (dB)	ANTENNA HEIGHT (m)	TABLE ANGLE (Degree)	RAW VALUE (dBuV)	CORRECTION FACTOR (dB/m)
1	4904.00	40.0 PK	74.0	-34.0	1.02 V	360	37.53	2.47
2	4904.00	30.3 AV	54.0	-23.7	1.02 V	360	27.83	2.47
3	7356.00	45.7 PK	74.0	-28.3	1.99 V	329	36.52	9.18
4	7356.00	35.9 AV	54.0	-18.1	1.99 V	329	26.72	9.18

REMARKS:

1. Emission Level(dBuV/m) = Raw Value(dBuV) + Correction Factor(dB/m)
2. Correction Factor(dB/m) = Antenna Factor(dB/m) + Cable Factor(dB) – Pre-Amplifier Factor(dB)
3. The other emission levels were very low against the limit.
4. Margin value = Emission Level – Limit value

Below 1GHz data

802.11g

CHANNEL	TX Channel 6	DETECTOR FUNCTION	Quasi-Peak (QP)
FREQUENCY RANGE	30MHz ~ 1GHz		

ANTENNA POLARITY & TEST DISTANCE: HORIZONTAL AT 3 M

NO.	FREQ. (MHz)	EMISSION LEVEL (dBuV/m)	LIMIT (dBuV/m)	MARGIN (dB)	ANTENNA HEIGHT (m)	TABLE ANGLE (Degree)	RAW VALUE (dBuV)	CORRECTION FACTOR (dB/m)
1	68.82	30.3 QP	40.0	-9.7	2.00 H	36	30.93	-0.66
2	149.99	33.8 QP	43.5	-9.7	2.00 H	80	32.84	0.96
3	250.00	42.7 QP	46.0	-3.3	1.00 H	297	42.84	-0.17
4	349.98	32.0 QP	46.0	-14.0	1.00 H	68	29.25	2.78
5	391.49	38.6 QP	46.0	-7.4	1.00 H	206	34.75	3.89
6	922.33	37.5 QP	46.0	-8.5	1.00 H	260	23.58	13.96

ANTENNA POLARITY & TEST DISTANCE: VERTICAL AT 3 M

NO.	FREQ. (MHz)	EMISSION LEVEL (dBuV/m)	LIMIT (dBuV/m)	MARGIN (dB)	ANTENNA HEIGHT (m)	TABLE ANGLE (Degree)	RAW VALUE (dBuV)	CORRECTION FACTOR (dB/m)
1	32.51	35.4 QP	40.0	-4.6	1.50 V	0	35.79	-0.40
2	38.95	32.0 QP	40.0	-8.0	1.00 V	329	31.70	0.29
3	49.81	33.8 QP	40.0	-6.3	1.00 V	105	32.73	1.02
4	250.00	35.8 QP	46.0	-10.2	1.50 V	360	35.99	-0.17
5	391.49	34.6 QP	46.0	-11.4	1.00 V	298	30.68	3.89
6	450.01	34.5 QP	46.0	-11.5	1.00 V	57	28.94	5.59

REMARKS:

1. Emission Level(dBuV/m) = Raw Value(dBuV) + Correction Factor(dB/m)
2. Correction Factor(dB/m) = Antenna Factor(dB/m) + Cable Factor(dB) – Pre-Amplifier Factor(dB)
3. The other emission levels were very low against the limit.
4. Margin value = Emission Level – Limit value

4.2 Conducted Emission Measurement

4.2.1 Limits of Conducted Emission Measurement

Frequency (MHz)	Conducted Limit (dBuV)	
	Quasi-peak	Average
0.15 - 0.5	66 - 56	56 - 46
0.50 - 5.0	56	46
5.0 - 30.0	60	50

Note: 1. The lower limit shall apply at the transition frequencies.

2. The limit decreases in line with the logarithm of the frequency in the range of 0.15 to 0.50MHz.

4.2.2 Test Instruments

DESCRIPTION & MANUFACTURER	MODEL NO.	SERIAL NO.	CALIBRATED DATE	CALIBRATED UNTIL
Test Receiver R&S	ESCS 30	847124/029	Oct. 23, 2015	Oct. 22, 2016
Line-Impedance Stabilization Network (for EUT) R&S	ESH3-Z5	848773/004	Oct. 28, 2015	Oct. 27, 2016
RF Cable	5D-FB	COACAB-002	Mar. 04, 2016	Mar. 03, 2017
Software BVADT	BVADT_Cond_ V7.3.7.3	NA	NA	NA

Note:

1. The calibration interval of the above test instruments are 12 months and the calibrations are traceable to NML/ROC and NIST/USA.
2. The test was performed in Shielded Room No. 1.
- 3 Tested Date: Apr. 29, 2016

4.2.3 Test Procedures

- The EUT was placed 0.4 meters from the conducting wall of the shielded room with EUT being connected to the power mains through a line impedance stabilization network (LISN). Other support units were connected to the power mains through another LISN. The two LISNs provide 50 ohm/ 50uH of coupling impedance for the measuring instrument.
- Both lines of the power mains connected to the EUT were checked for maximum conducted interference.
- The frequency range from 150kHz to 30MHz was searched. Emission levels under (Limit - 20dB) was not recorded.

NOTE: The resolution bandwidth and video bandwidth of test receiver is 9kHz for quasi-peak detection (QP) and average detection (AV) at frequency 0.15MHz-30MHz.

4.2.4 Deviation from Test Standard

No deviation.

4.2.5 Test Setup

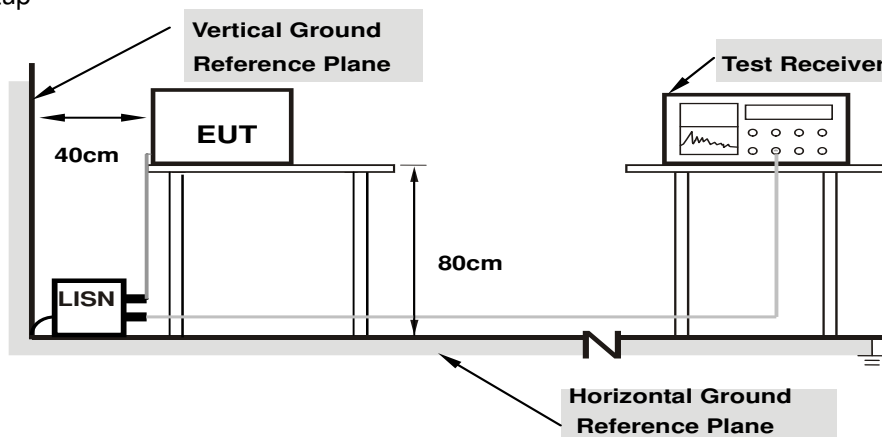

For the actual test configuration, please refer to the attached file (Test Setup Photo).

4.2.6 EUT Operating Conditions

Same as 4.1.6.

4.2.7 Test Results

Phase	Line (L)	Detector Function	Quasi-Peak (QP) / Average (AV)
-------	----------	-------------------	--------------------------------

No	Freq. [MHz]	Corr.	Reading Value		Emission Level		Limit		Margin	
		Factor (dB)	[dB (uV)]		[dB (uV)]		[dB (uV)]		(dB)	
			Q.P.	AV.	Q.P.	AV.	Q.P.	AV.	Q.P.	AV.
1	0.15000	10.34	41.98	25.95	52.32	36.29	66.00	56.00	-13.68	-19.71
2	0.15781	10.33	38.89	21.43	49.22	31.76	65.58	55.58	-16.36	-23.82
3	0.29063	10.31	33.15	20.98	43.46	31.29	60.51	50.51	-17.04	-19.21
4	3.93359	10.61	18.78	11.03	29.39	21.64	56.00	46.00	-26.61	-24.36
5	4.50000	10.65	19.75	14.01	30.40	24.66	56.00	46.00	-25.60	-21.34
6	24.00000	11.79	16.37	14.32	28.16	26.11	60.00	50.00	-31.84	-23.89

REMARKS:

1. Q.P. and AV. are abbreviations of quasi-peak and average individually.
2. The emission levels of other frequencies were very low against the limit.
3. Margin value = Emission level - Limit value
4. Correction factor = Insertion loss + Cable loss
5. Emission Level = Correction Factor + Reading Value-

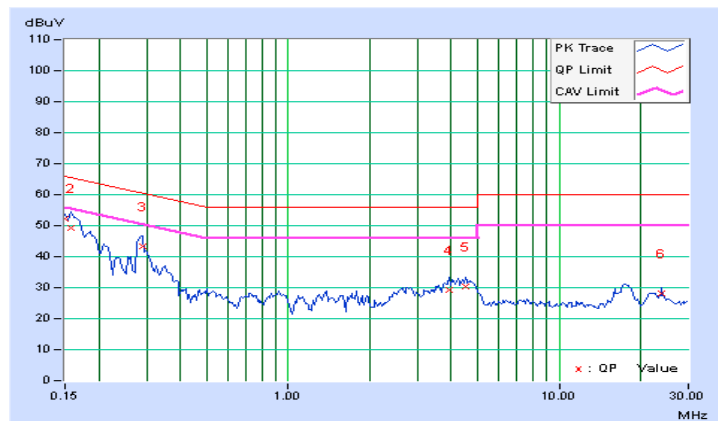

Phase	Neutral (N)	Detector Function	Quasi-Peak (QP) / Average (AV)
-------	-------------	-------------------	--------------------------------

No	Freq. [MHz]	Corr.	Reading Value		Emission Level		Limit		Margin	
		Factor (dB)	[dB (uV)]		[dB (uV)]		[dB (uV)]		(dB)	
			Q.P.	AV.	Q.P.	AV.	Q.P.	AV.	Q.P.	AV.
1	0.15000	10.32	41.88	25.67	52.20	35.99	66.00	56.00	-13.80	-20.01
2	0.16562	10.31	39.61	25.20	49.92	35.51	65.18	55.18	-15.26	-19.67
3	0.28087	10.30	34.28	29.14	44.58	39.44	60.79	50.79	-16.21	-11.35
4	3.74219	10.55	21.74	14.39	32.29	24.94	56.00	46.00	-23.71	-21.06
5	18.20313	11.37	13.55	9.12	24.92	20.49	60.00	50.00	-35.08	-29.51
6	21.58984	11.47	12.76	7.78	24.23	19.25	60.00	50.00	-35.77	-30.75

REMARKS:

1. Q.P. and AV. are abbreviations of quasi-peak and average individually.
2. The emission levels of other frequencies were very low against the limit.
3. Margin value = Emission level - Limit value
4. Correction factor = Insertion loss + Cable loss
5. Emission Level = Correction Factor + Reading Value-

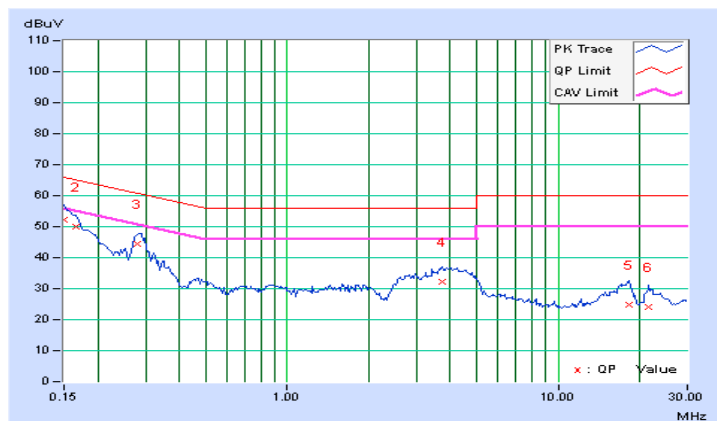

4.3 6dB Bandwidth Measurement

4.3.1 Limits of 6dB Bandwidth Measurement

The minimum of 6dB Bandwidth Measurement is 0.5 MHz.

4.3.2 Test Setup

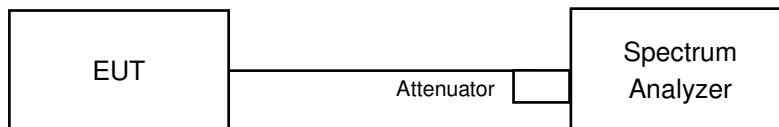

4.3.3 Test Instruments

Refer to section 4.1.2 to get information of above instrument.

4.3.4 Test Procedure

- a. Set resolution bandwidth (RBW) = 100kHz
- b. Set the video bandwidth (VBW) $\geq 3 \times$ RBW, Detector = Peak.
- c. Trace mode = max hold.
- d. Sweep = auto couple.
- e. Measure the maximum width of the emission that is constrained by the frequencies associated with the two amplitude points (upper and lower) that are attenuated by 6 dB relative to the maximum level measured in the fundamental emission

4.3.5 Deviation from Test Standard

No deviation.

4.3.6 EUT Operating Conditions

The software provided by client to enable the EUT under transmission condition continuously at lowest, middle and highest channel frequencies individually.

4.3.7 Test Result

1TX- Antenna 1

802.11b

Channel	Frequency (MHz)	6dB Bandwidth (MHz)	Minimum Limit (MHz)	Pass / Fail
1	2412	9.09	0.5	PASS
6	2437	9.12	0.5	PASS
11	2462	8.57	0.5	PASS

802.11g

Channel	Frequency (MHz)	6dB Bandwidth (MHz)	Minimum Limit (MHz)	Pass / Fail
1	2412	15.73	0.5	PASS
6	2437	15.58	0.5	PASS
11	2462	15.34	0.5	PASS

802.11n (20MHz)

Channel	Frequency (MHz)	6dB Bandwidth (MHz)	Minimum Limit (MHz)	Pass / Fail
1	2412	15.50	0.5	PASS
6	2437	15.17	0.5	PASS
11	2462	15.46	0.5	PASS

802.11n (40MHz)

Channel	Frequency (MHz)	6dB Bandwidth (MHz)	Minimum Limit (MHz)	Pass / Fail
3	2412	36.46	0.5	PASS
6	2437	36.44	0.5	PASS
9	2462	36.44	0.5	PASS

Spectrum Plot of Worst Value

802.11b : CH11

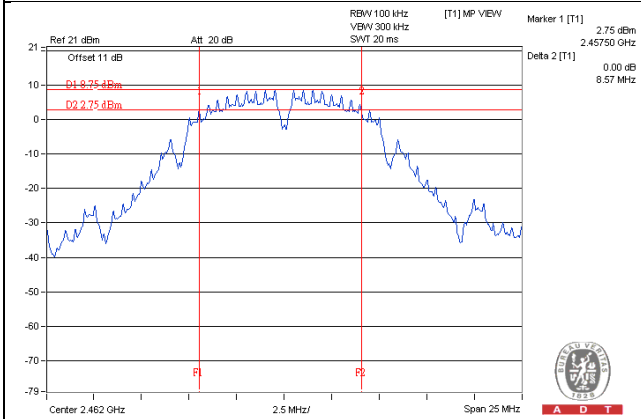

802.11g : CH11

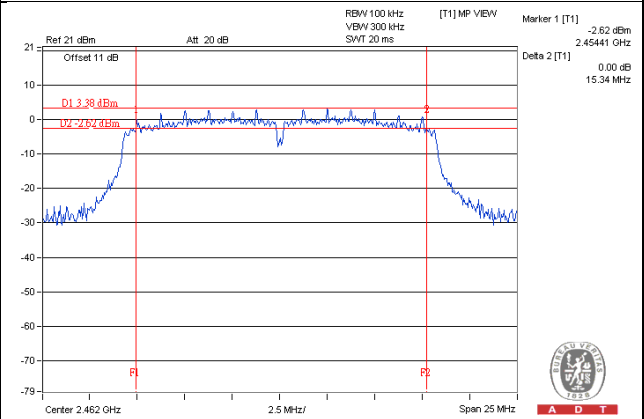

802.11n (20MHz) : CH6

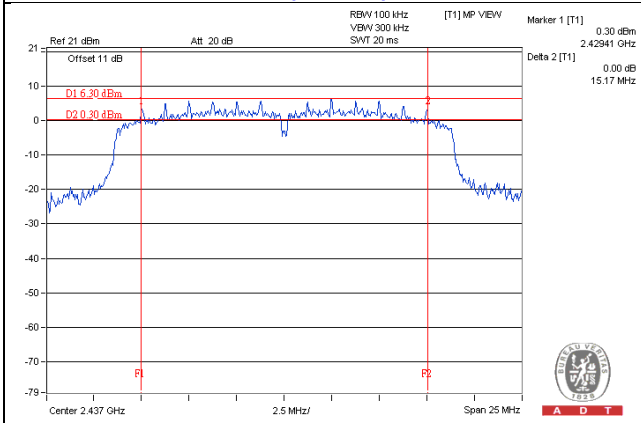

802.11n (40MHz) : CH6

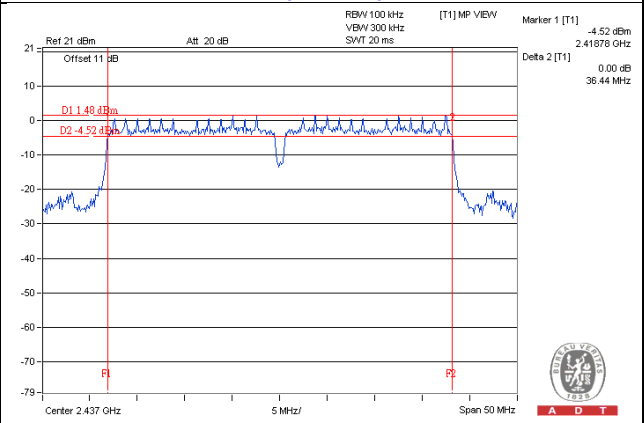

**2TX****802.11g**

Channel	Frequency (MHz)	6dB Bandwidth (MHz)		Minimum Limit (MHz)	Pass / Fail
		Chain 0	Chain 1		
1	2412	15.85	15.91	0.5	PASS
6	2437	15.38	16.07	0.5	PASS
11	2462	15.59	15.65	0.5	PASS

802.11n (20MHz)

Channel	Frequency (MHz)	6dB Bandwidth (MHz)		Minimum Limit (MHz)	Pass / Fail
		Chain 0	Chain 1		
1	2412	15.37	16.39	0.5	PASS
6	2437	15.20	16.34	0.5	PASS
11	2462	15.26	16.38	0.5	PASS

802.11n (40MHz)

Channel	Frequency (MHz)	6dB Bandwidth (MHz)		Minimum Limit (MHz)	Pass / Fail
		Chain 0	Chain 1		
3	2422	36.44	36.44	0.5	Pass
6	2437	36.43	36.44	0.5	Pass
9	2452	36.44	36.44	0.5	Pass

Spectrum Plot of Worst Value

802.11g / Chain 0 : CH6

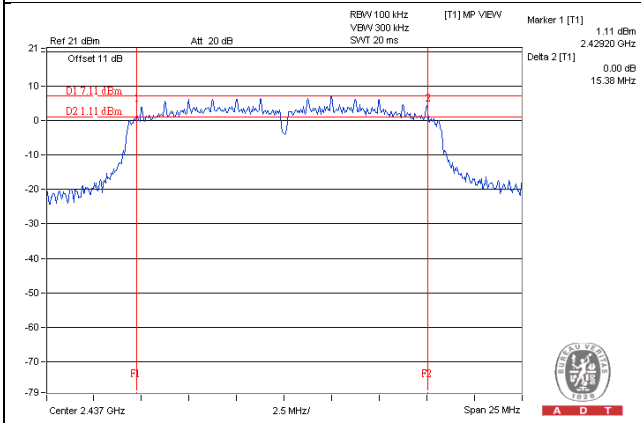

802.11n (20MHz) / Chain 0 : CH6

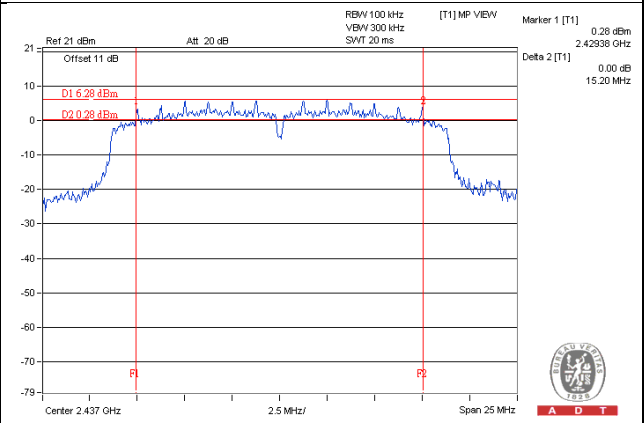

802.11n (40MHz) / Chain 0 : CH6

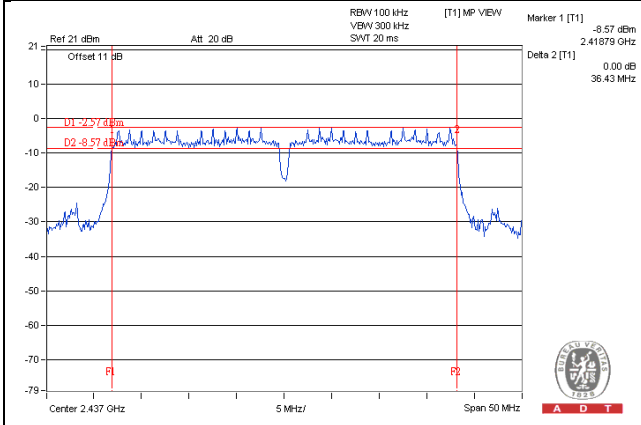

4.4 Conducted Output Power Measurement

4.4.1 Limits of Conducted Output Power Measurement

For systems using digital modulation in the 2400–2483.5 MHz bands: 1 Watt (30dBm)

Per KDB 662911 D01 Multiple Transmitter Output Method of conducted output power measurement on IEEE 802.11 devices,

Array Gain = 0 dB (i.e., no array gain) for $NANT \leq 4$;

Array Gain = 0 dB (i.e., no array gain) for channel widths ≥ 40 MHz for any NANT;

Array Gain = $5 \log(NANT/NSS)$ dB or 3 dB, whichever is less for 20-MHz channel widths with $NANT \geq 5$.

For power measurements on all other devices: Array Gain = $10 \log(NANT/NSS)$ dB.

4.4.2 Test Setup

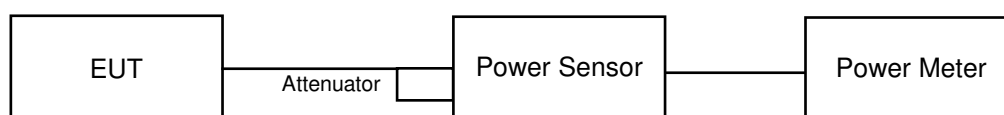

4.4.3 Test Instruments

Refer to section 4.1.2 to get information of above instrument.

4.4.4 Test Procedures

A average power sensor was used on the output port of the EUT. A power meter was used to read the response of the average power sensor and set the detector to AVERAGE . Record the power level.

4.4.5 Deviation from Test Standard

No deviation.

4.4.6 EUT Operating Conditions

Same as Item 4.3.6.

4.4.7 Test Results

1TX – Antenna 1

802.11b

Channel	Frequency (MHz)	Average Power (mW)	Average Power (dBm)	Limit (dBm)	Pass/Fail
1	2412	50.119	17.00	30	Pass
6	2437	127.644	21.06	30	Pass
11	2462	54.325	17.35	30	Pass

802.11g

Channel	Frequency (MHz)	Average Power (mW)	Average Power (dBm)	Limit (dBm)	Pass/Fail
1	2412	29.648	14.72	30	Pass
6	2437	71.945	18.57	30	Pass
11	2462	23.878	13.78	30	Pass

802.11n (20MHz)

Channel	Frequency (MHz)	Average Power (mW)	Average Power (dBm)	Limit (dBm)	Pass/Fail
1	2412	27.733	14.43	30	Pass
6	2437	59.429	17.74	30	Pass
11	2462	21.281	13.28	30	Pass

802.11n (40MHz)

Channel	Frequency (MHz)	Average Power (mW)	Average Power (dBm)	Limit (dBm)	Pass/Fail
3	2422	11.246	10.51	30	Pass
6	2437	21.038	13.23	30	Pass
9	2452	12.912	11.11	30	Pass

**1TX – Antenna 2****802.11b**

Channel	Frequency (MHz)	Average Power (mW)	Average Power (dBm)	Limit (dBm)	Pass/Fail
1	2412	66.988	18.26	30	Pass
6	2437	125.314	20.98	30	Pass
11	2462	79.799	19.02	30	Pass

802.11g

Channel	Frequency (MHz)	Average Power (mW)	Average Power (dBm)	Limit (dBm)	Pass/Fail
1	2412	51.761	17.14	30	Pass
6	2437	106.66	20.28	30	Pass
11	2462	52.966	17.24	30	Pass

802.11n (20MHz)

Channel	Frequency (MHz)	Average Power (mW)	Average Power (dBm)	Limit (dBm)	Pass/Fail
1	2412	36.058	15.57	30	Pass
6	2437	103.276	20.14	30	Pass
11	2462	43.451	16.38	30	Pass

802.11n (40MHz)

Channel	Frequency (MHz)	Average Power (mW)	Average Power (dBm)	Limit (dBm)	Pass/Fail
3	2422	23.067	13.63	30	Pass
6	2437	41.305	16.16	30	Pass
9	2452	31.769	15.02	30	Pass

2TX
802.11g

Chan.	Freq. (MHz)	Avg. Power (dBm)		Total Power (mW)	Total Power (dBm)	Limit (dBm)	Pass / Fail
		Chain 0	Chain 1				
1	2412	11.42	11.74	28.796	14.59	30	Pass
6	2437	17.60	18.38	126.409	21.02	30	Pass
11	2462	11.29	11.78	28.525	14.55	30	Pass

802.11n (20MHz)

Chan.	Freq. (MHz)	Avg. Power (dBm)		Total Power (mW)	Total Power (dBm)	Limit (dBm)	Pass / Fail
		Chain 0	Chain 1				
1	2412	12.15	12.75	35.242	15.47	30	Pass
6	2437	17.49	18.24	122.786	20.89	30	Pass
11	2462	12.25	11.68	31.511	14.98	30	Pass

802.11n (40MHz)

Chan.	Freq. (MHz)	Avg. Power (dBm)		Total Power (mW)	Total Power (dBm)	Limit (dBm)	Pass / Fail
		Chain 0	Chain 1				
3	2422	11.33	11.73	28.477	14.54	30	Pass
6	2437	13.19	14.07	46.372	16.66	30	Pass
9	2452	10.46	11.04	23.823	13.77	30	Pass

4.5 Power Spectral Density Measurement

4.5.1 Limits of Power Spectral Density Measurement

The Maximum of Power Spectral Density Measurement is 8dBm.

4.5.2 Test Setup

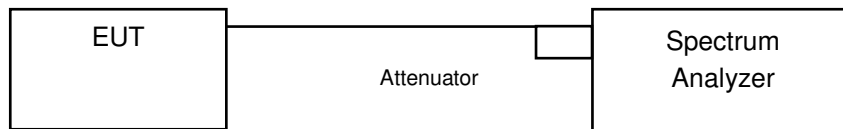

4.5.3 Test Instruments

Refer to section 4.1.2 to get information of above instrument.

4.5.4 Test Procedure

- Set instrument center frequency to DTS channel center frequency.
- Set span to at least 1.5 times the OBW.
- Set RBW to: $3 \text{ kHz} \leq \text{RBW} \leq 100 \text{ kHz}$.
- Set VBW $\geq 3 \times \text{RBW}$.
- Detector = power averaging (RMS) or sample detector (when RMS not available).
- Ensure that the number of measurement points in the sweep $\geq 2 \times \text{span}/\text{RBW}$.
- Sweep time = auto couple.
- Employ trace averaging (RMS) mode over a minimum of 100 traces.
- Use the peak marker function to determine the maximum amplitude level.

4.5.5 Deviation from Test Standard

No deviation.

4.5.6 EUT Operating Condition

Same as Item 4.3.6

4.5.7 Test Results

1TX – Antenna 1

802.11b

Channel	Freq. (MHz)	PSD (dBm/10kHz)	Limit (dBm/3kHz)	Pass /Fail
1	2412	-10.64	8.00	Pass
6	2437	-7.44	8.00	Pass
11	2462	-10.73	8.00	Pass

802.11g

Channel	Freq. (MHz)	PSD (dBm/10kHz)	Limit (dBm/3kHz)	Pass /Fail
1	2412	-15.16	8.00	Pass
6	2437	-11.96	8.00	Pass
11	2462	-15.85	8.00	Pass

802.11n (20MHz)

Channel	Freq. (MHz)	PSD (dBm/10kHz)	Limit (dBm/3kHz)	Pass /Fail
1	2412	-17.30	8.00	Pass
6	2437	-12.99	8.00	Pass
11	2462	-16.36	8.00	Pass

802.11n (40MHz)

Channel	Freq. (MHz)	PSD (dBm/10kHz)	Limit (dBm/3kHz)	Pass /Fail
3	2422	-21.33	8.00	Pass
6	2437	-17.14	8.00	Pass
9	2452	-21.41	8.00	Pass

Spectrum Plot of Worst Value

802.11b : CH6

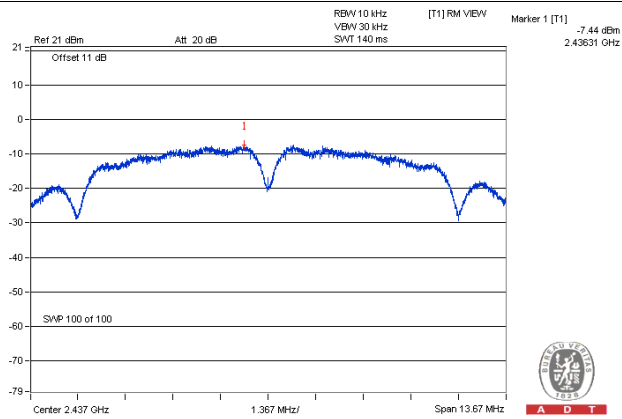

802.11g : CH6

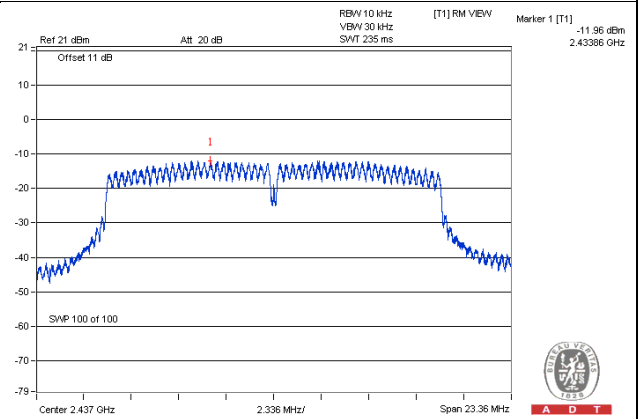

802.11n (20MHz) : CH6

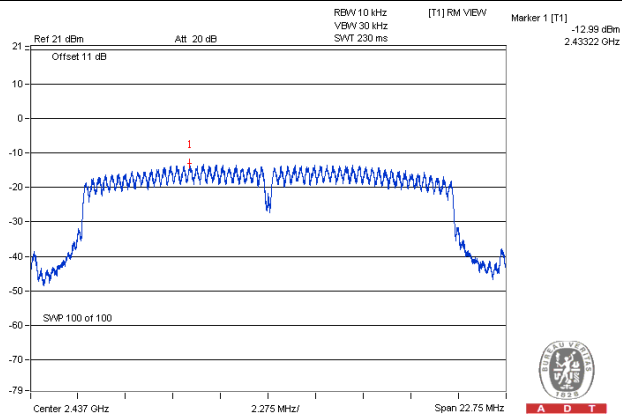

802.11n (40MHz) : CH6

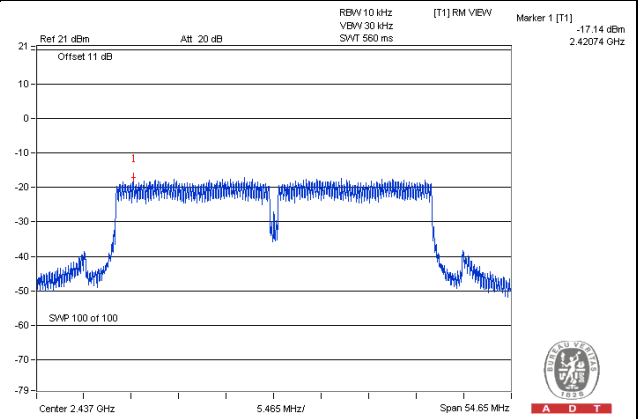

2TX
802.11g

TX chain	Channel	Freq. (MHz)	PSD (dBm/10kHz)	10 log (N=2) dB	Total PSD (dBm/3kHz)	Limit (dBm/3kHz)	Pass /Fail
0	1	2412	-17.47	3.01	-14.46	8.00	Pass
	6	2437	-12.60	3.01	-9.59	8.00	Pass
	11	2462	-18.30	3.01	-15.29	8.00	Pass
1	1	2412	-16.40	3.01	-13.39	8.00	Pass
	6	2437	-11.45	3.01	-8.44	8.00	Pass
	11	2462	-17.77	3.01	-14.76	8.00	Pass

Note: Directional gain = $10 \log[(10^{G1/20} + 10^{G2/20})^2 / 2] = 4.43\text{dBi} < 6\text{dBi}$, so the power density limit shall not be reduced.

802.11n (20MHz)

TX chain	Channel	Freq. (MHz)	PSD (dBm/10kHz)	10 log (N=2) dB	Total PSD (dBm/3kHz)	Limit (dBm/3kHz)	Pass /Fail
0	1	2412	-18.08	3.01	-15.07	8.00	Pass
	6	2437	-13.02	3.01	-10.01	8.00	Pass
	11	2462	-19.12	3.01	-16.11	8.00	Pass
1	1	2412	-16.89	3.01	-13.88	8.00	Pass
	6	2437	-12.17	3.01	-9.16	8.00	Pass
	11	2462	-17.78	3.01	-14.77	8.00	Pass

Note: Directional gain = $10 \log[(10^{G1/20} + 10^{G2/20})^2 / 2] = 4.43\text{dBi} < 6\text{dBi}$, so the power density limit shall not be reduced.

802.11n (40MHz)

TX chain	Channel	Freq. (MHz)	PSD (dBm/10kHz)	10 log (N=2) dB	Total PSD (dBm/3kHz)	Limit (dBm/3kHz)	Pass /Fail
0	3	2422	-22.73	3.01	-19.72	8.00	Pass
	6	2437	-21.14	3.01	-18.13	8.00	Pass
	9	2452	-22.48	3.01	-19.47	8.00	Pass
1	3	2422	-21.95	3.01	-18.94	8.00	Pass
	6	2437	-19.64	3.01	-16.63	8.00	Pass
	9	2452	-22.19	3.01	-19.18	8.00	Pass

Note: Directional gain = $10 \log[(10^{G1/20} + 10^{G2/20})^2 / 2] = 4.43\text{dBi} < 6\text{dBi}$, so the power density limit shall not be reduced.

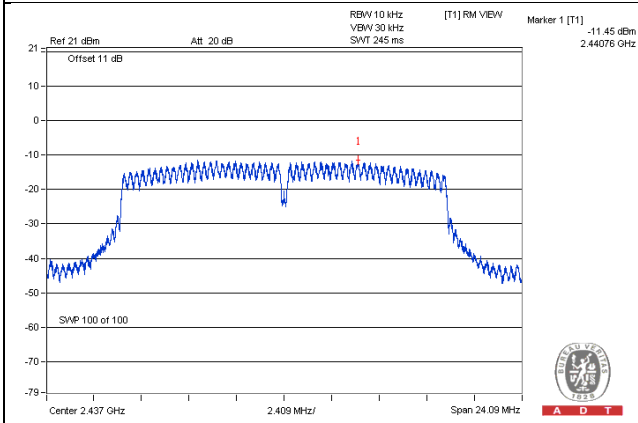
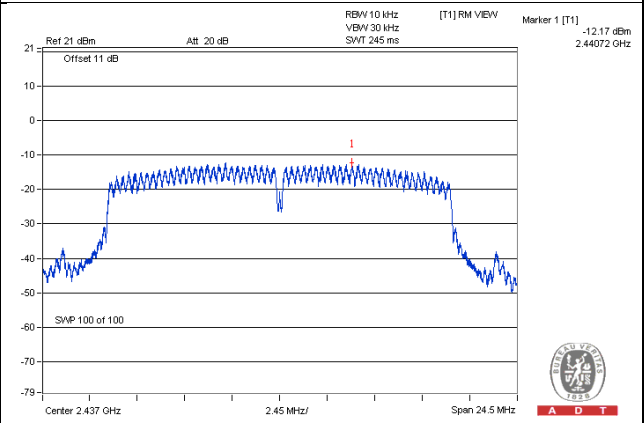
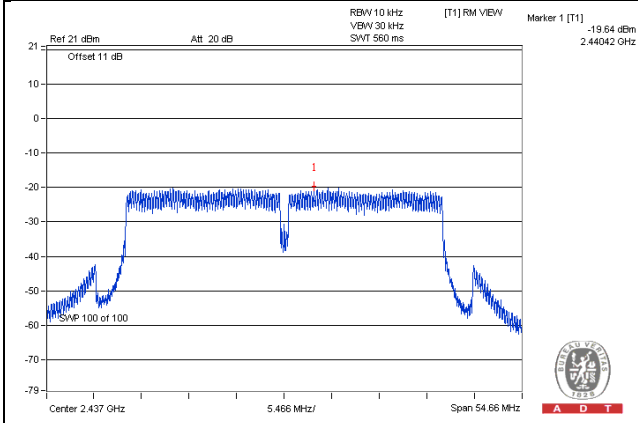
Spectrum Plot of Worst Value**802.11g / Chain 1 : CH6****802.11n (20MHz) / Chain 1 : CH6****802.11n (40MHz) / Chain 1 : CH6**

4.6 Conducted Out of Band Emission Measurement

4.6.1 Limits of Conducted Out of Band Emission Measurement

Below 30dB of the highest emission level of operating band (in 100kHz Resolution Bandwidth).

4.6.2 Test Setup

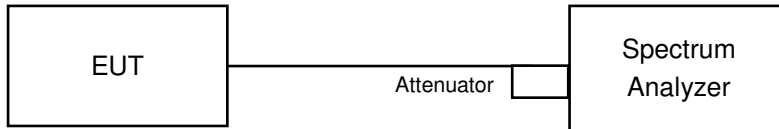

4.6.3 Test Instruments

Refer to section 4.1.2 to get information of above instrument.

4.6.4 Test Procedure

MEASUREMENT PROCEDURE REF

1. Set the RBW = 100 kHz.
2. Set the VBW ≥ 300 kHz.
3. Detector = peak.
4. Sweep time = auto couple.
5. Trace mode = max hold.
6. Allow trace to fully stabilize.
7. Use the peak marker function to determine the maximum power level in any 100 kHz band segment within the fundamental EBW.

MEASUREMENT PROCEDURE OOB

1. Set RBW = 100 kHz.
2. Set VBW ≥ 300 kHz.
3. Detector = peak.
4. Sweep = auto couple.
5. Trace Mode = max hold.
6. Allow trace to fully stabilize.
7. Use the peak marker function to determine the maximum amplitude level.

4.6.5 Deviation from Test Standard

No deviation.

4.6.6 EUT Operating Condition

Same as Item 4.3.6

4.6.7 Test Results

The spectrum plots are attached on the following pages. D1 line indicates the highest level, and D2 line indicates the 30dB offset below D1. It shows compliance with the requirement.

1TX - Antenna 1 802.11b

CH 1

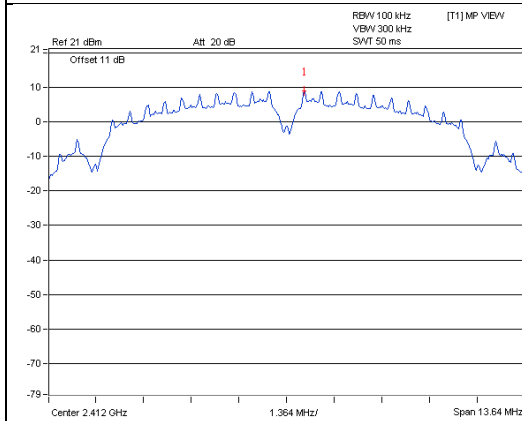

A D T

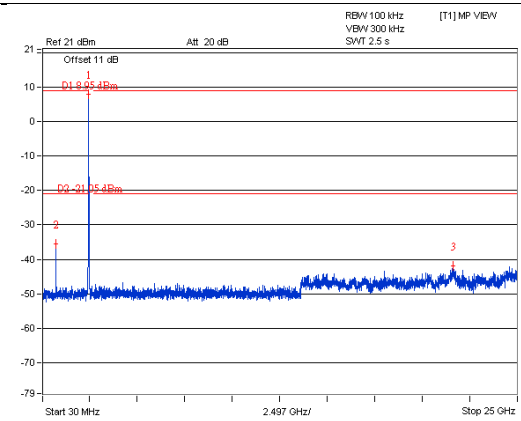

A D T

CH 6

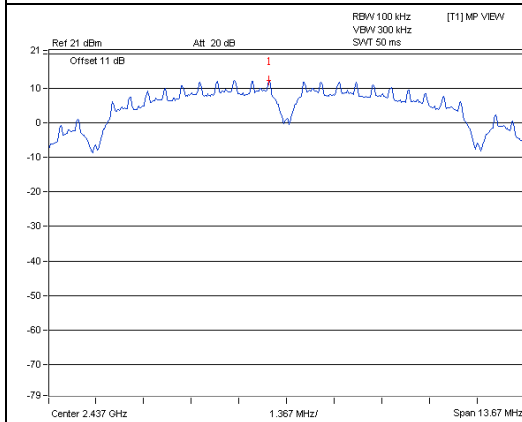

A D T

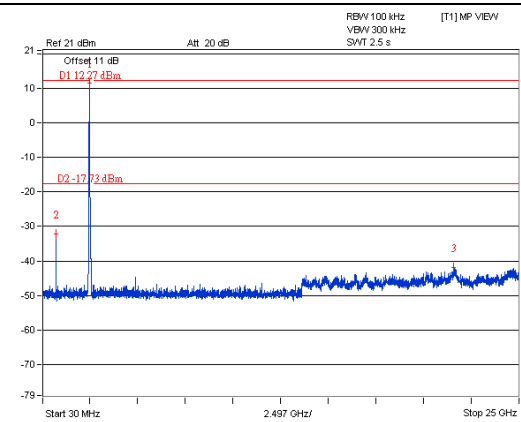

A D T

CH 11

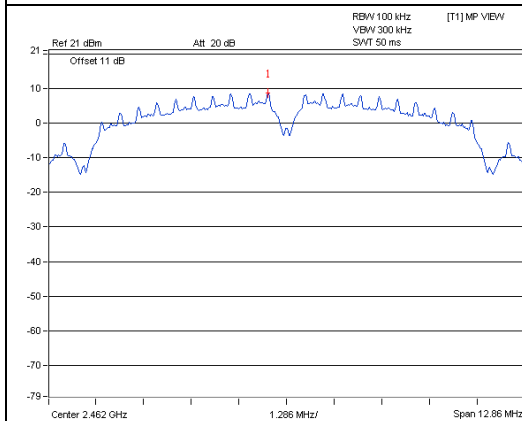

A D T

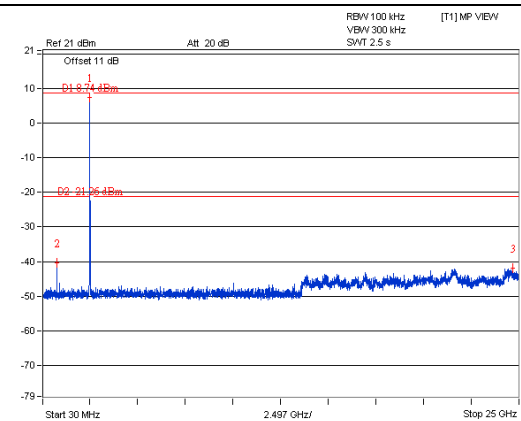

A D T

CH 1 Band edge

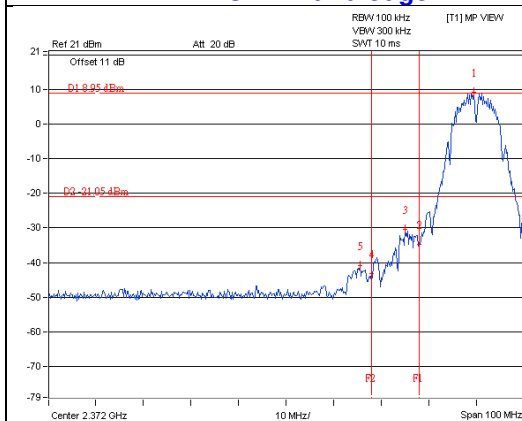

A D T

CH 11 Band edge

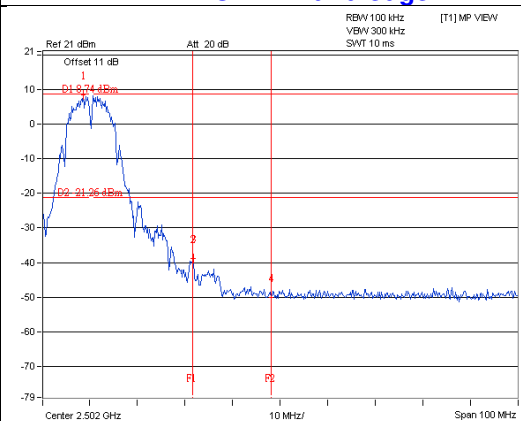

A D T

802.11g

CH 1

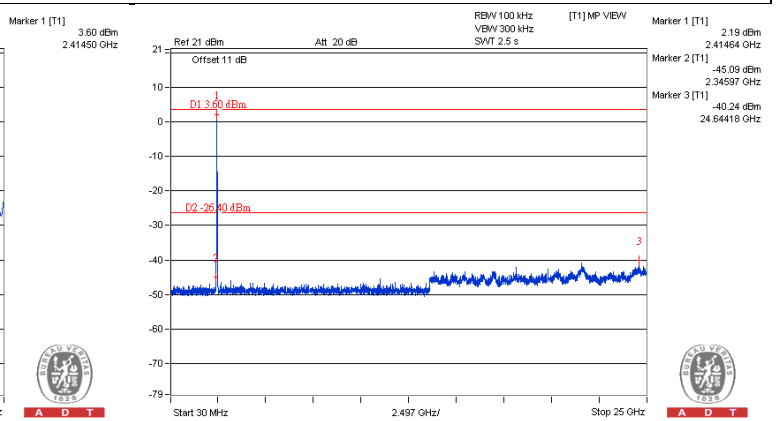
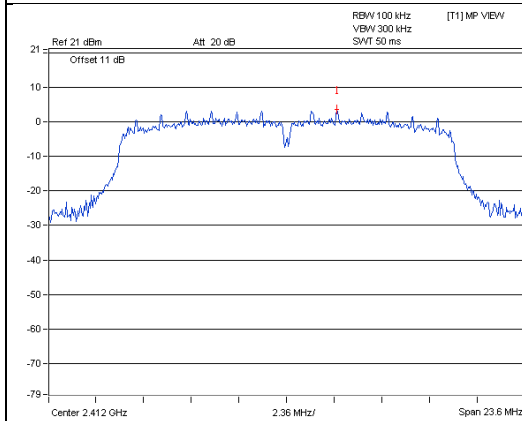

CH 6

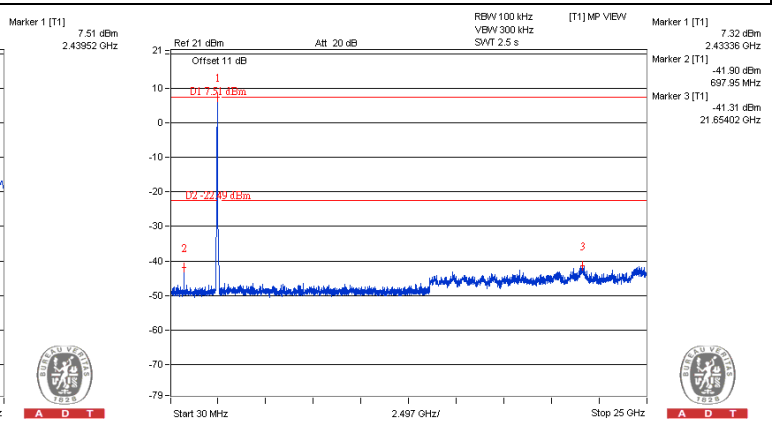
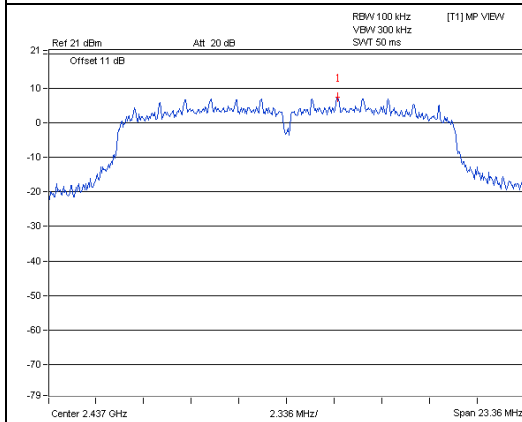

CH 11

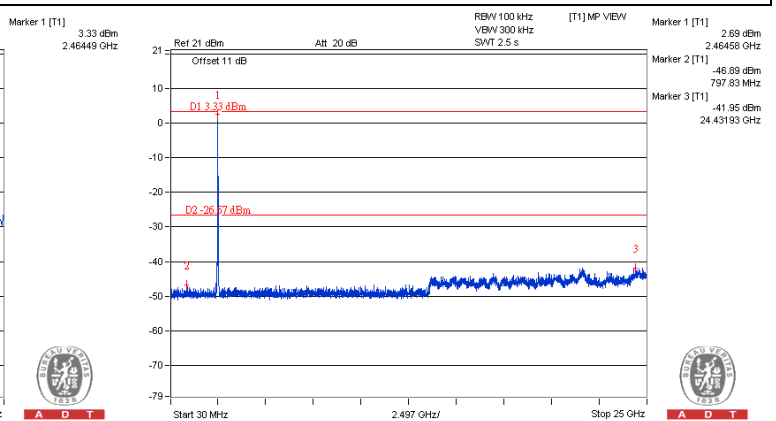
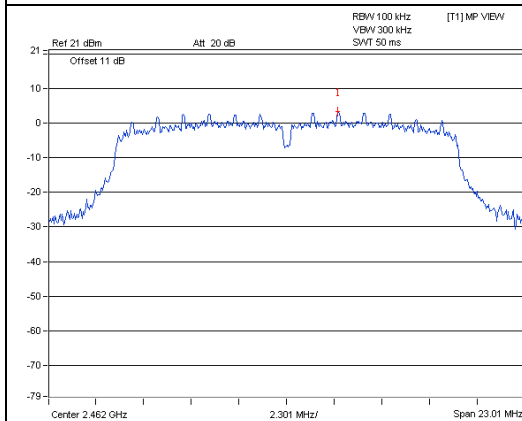

CH 1 Band edge

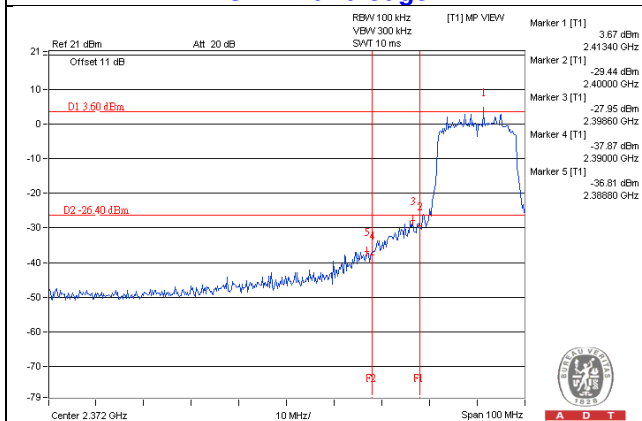

CH 11 Band edge

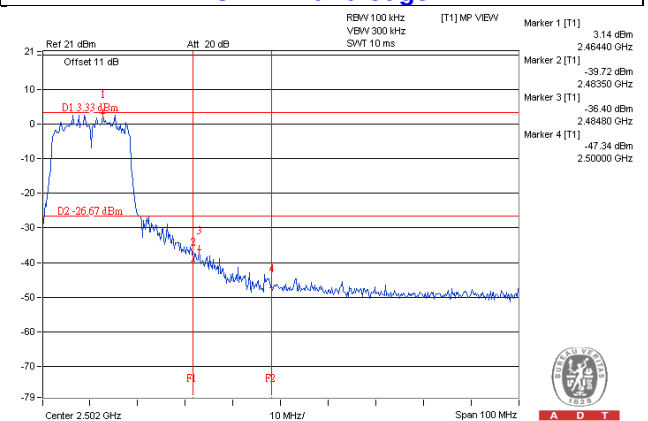

802.11n (20MHz)

CH 1

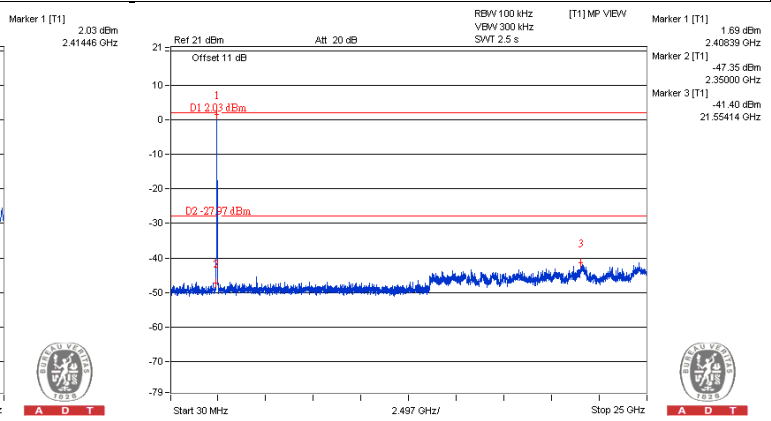
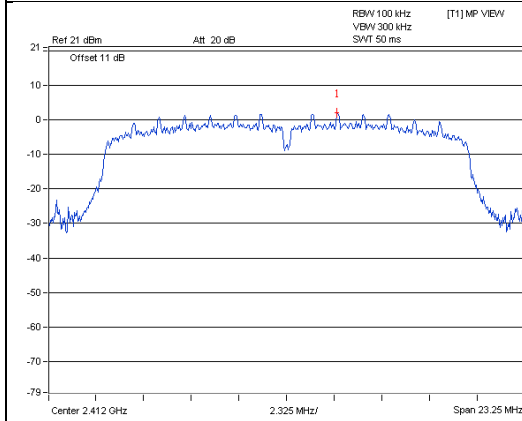

CH 6

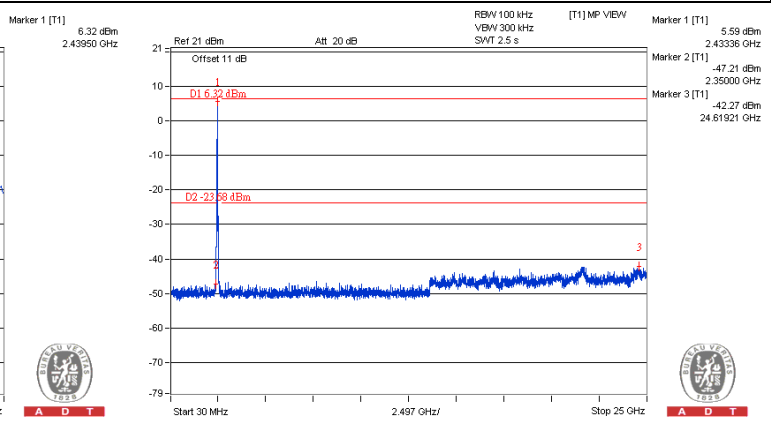
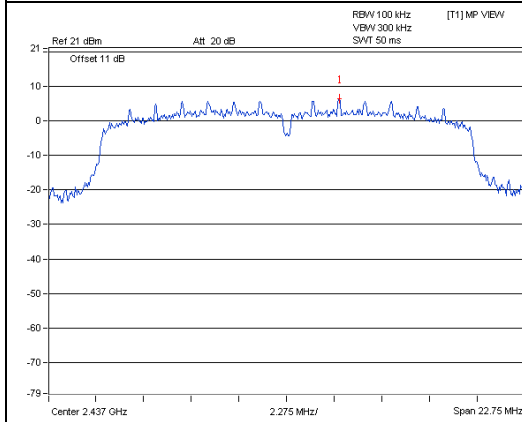

CH 11

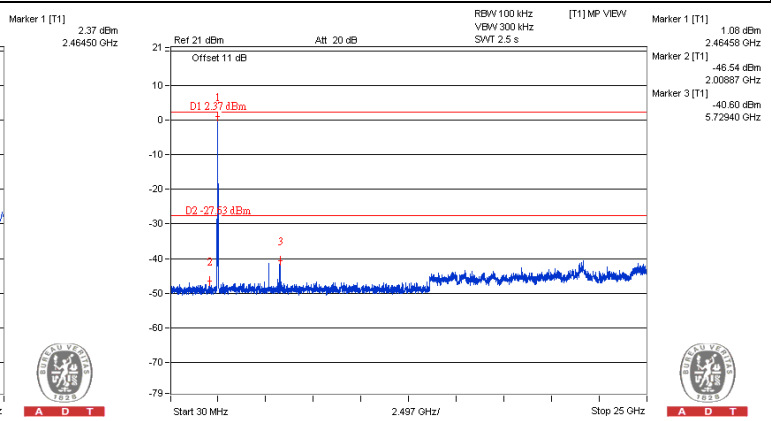
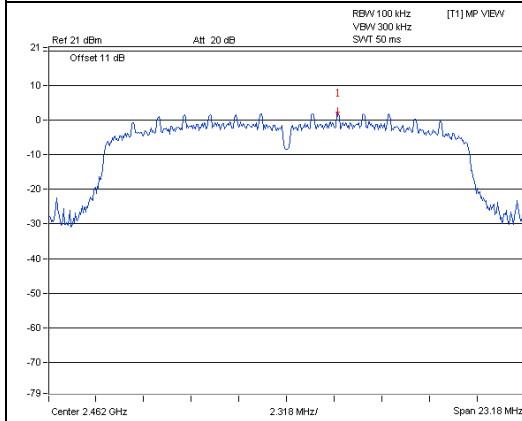

CH 1 Band edge

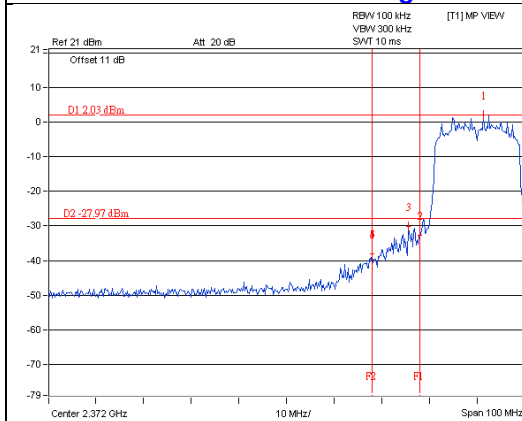

CH 11 Band edge

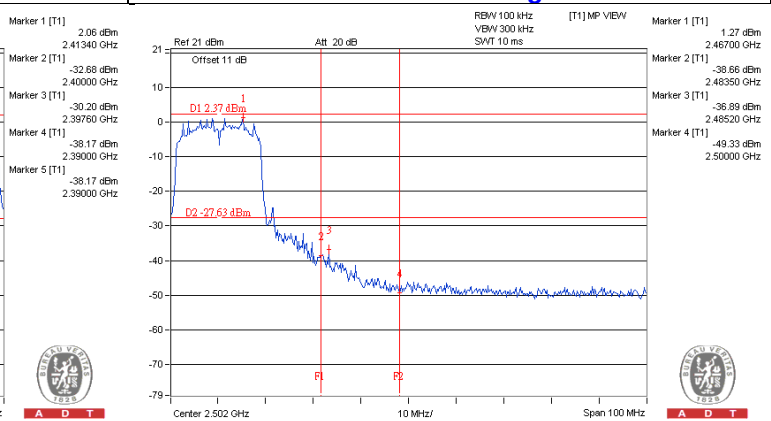

802.11n (40MHz)

CH 3

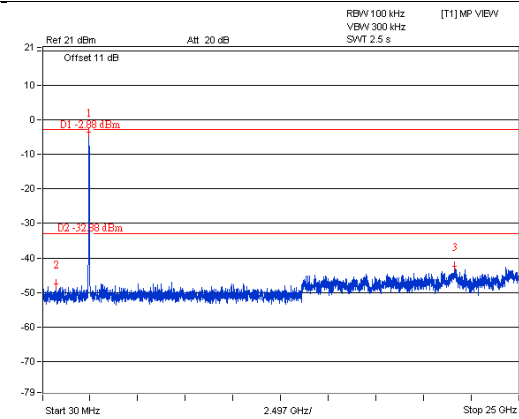
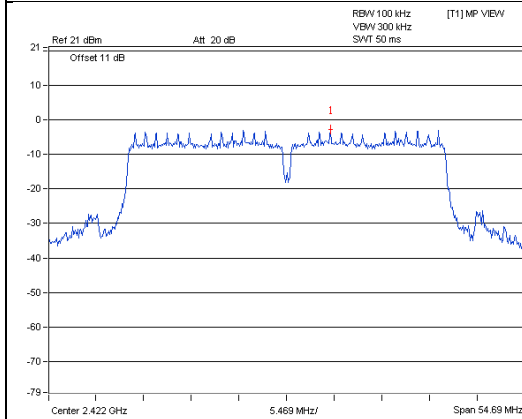

CH 6

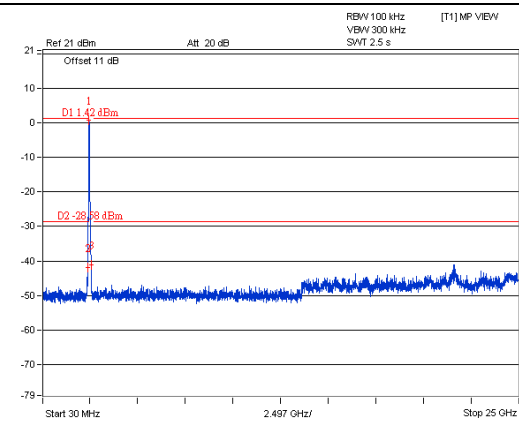
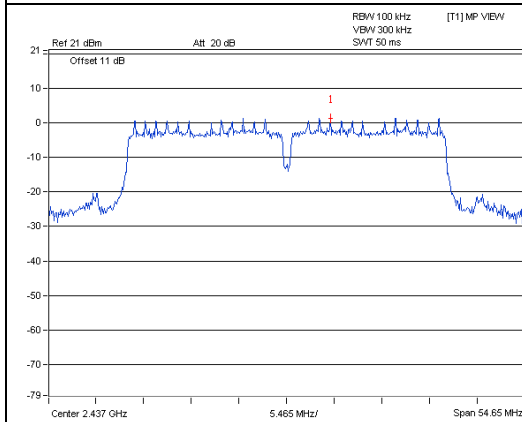

CH 9

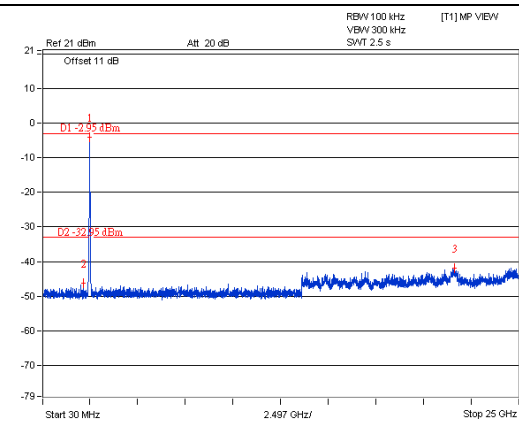
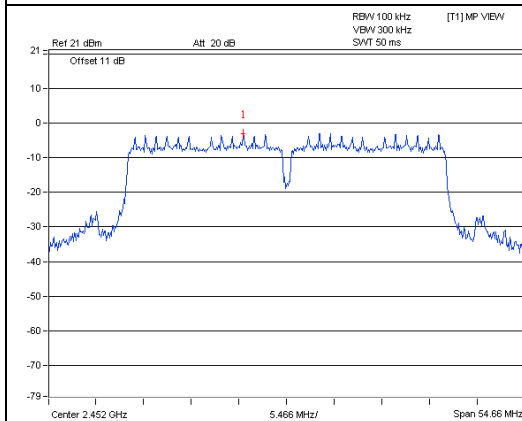

CH 3 Band edge

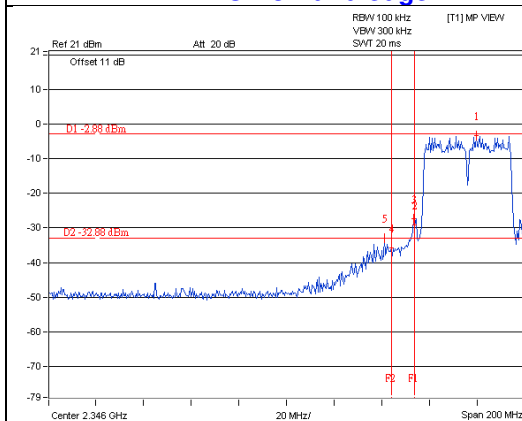

CH 9 Band edge

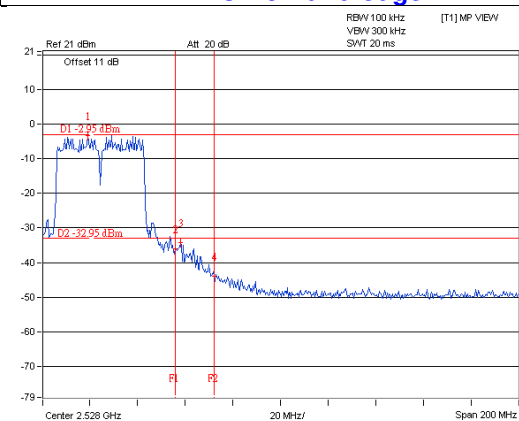

1TX – Antenna 2 802.11b

CH 1

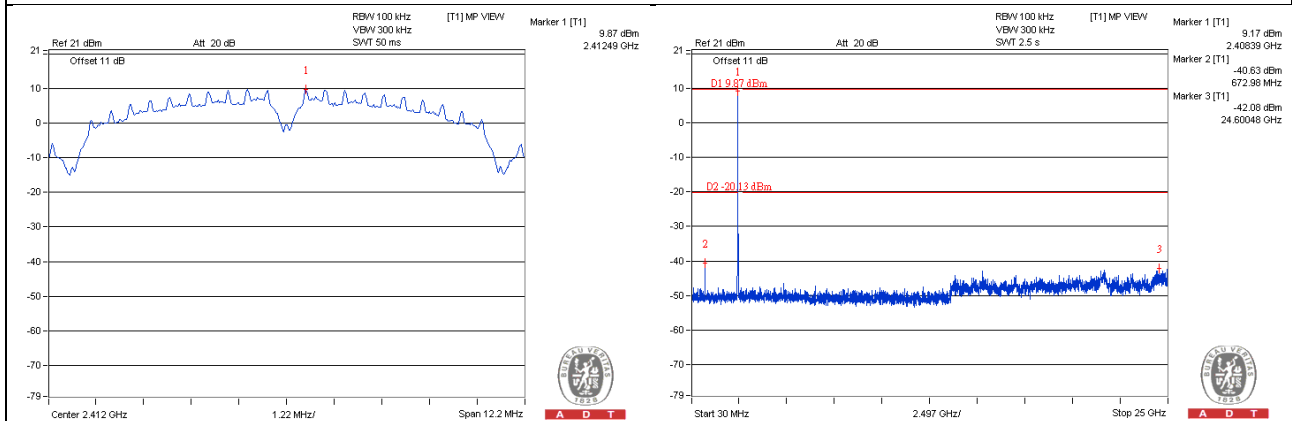

CH 6

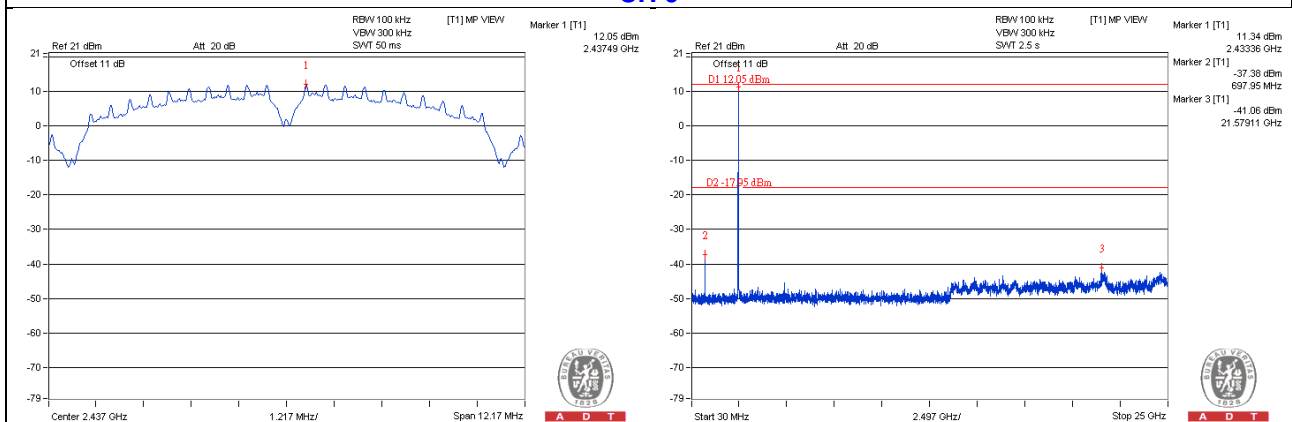

CH 11

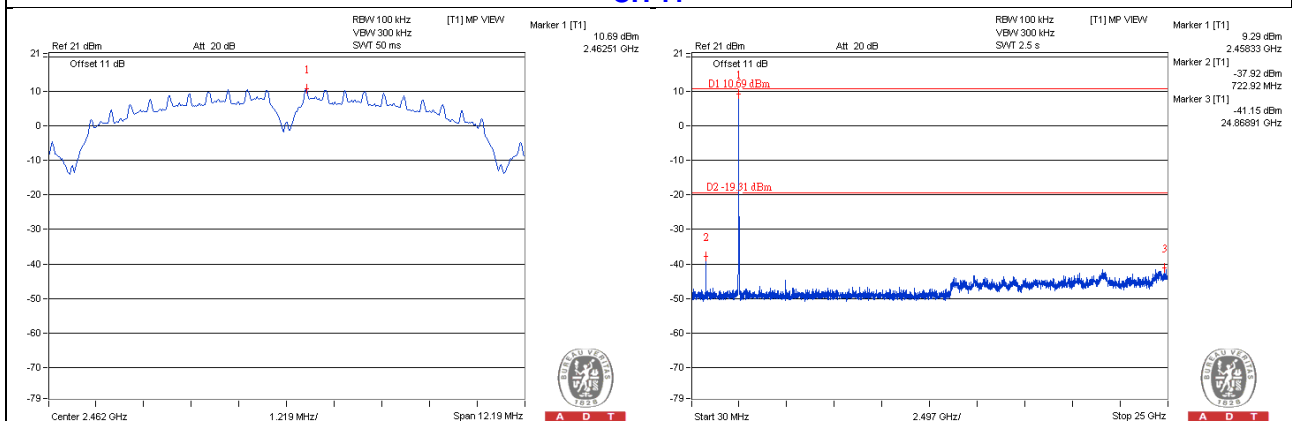

CH 1 Band edge

CH 11 Band edge

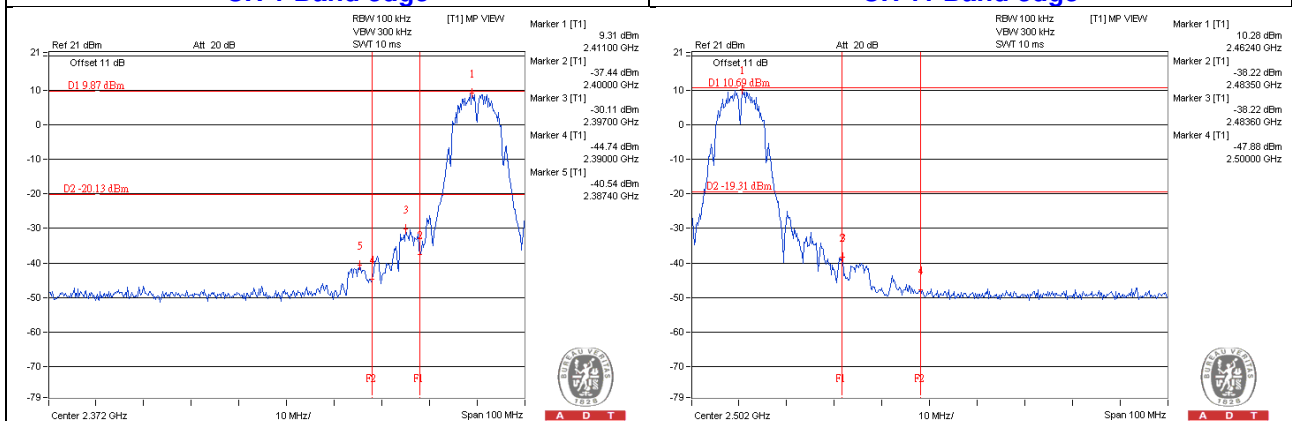

802.11g

CH 1

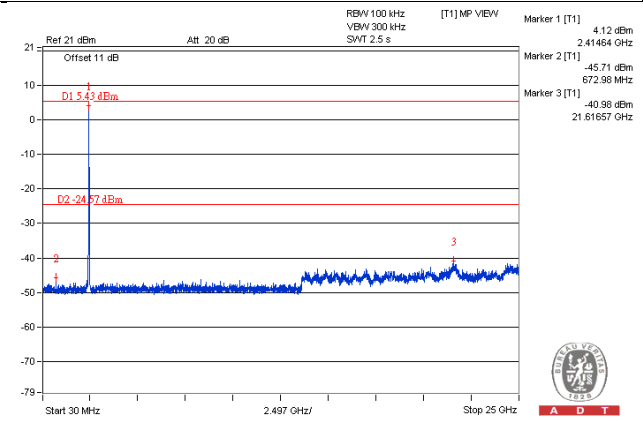
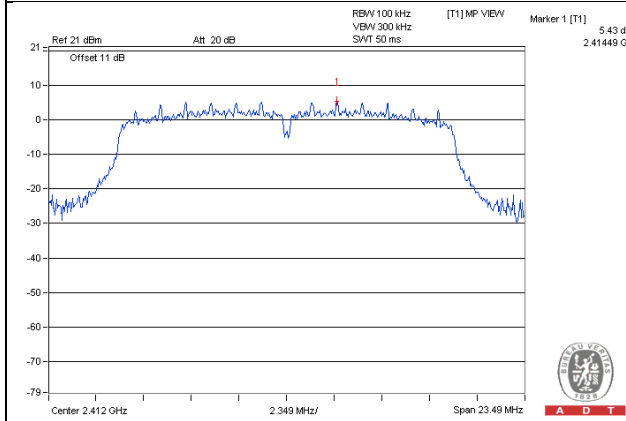

CH 6

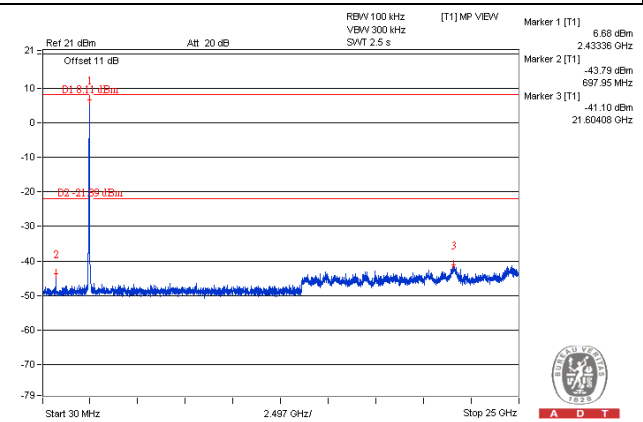
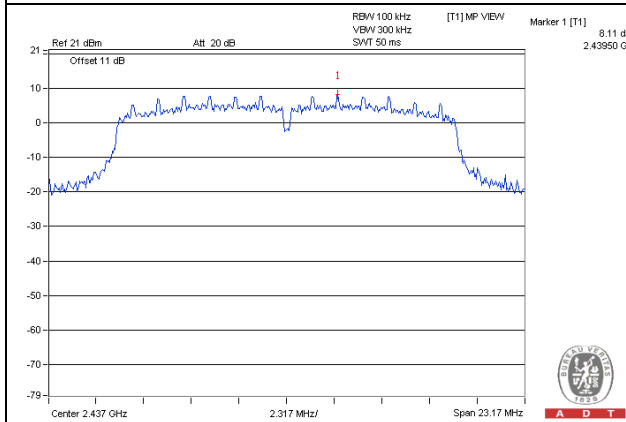

CH 11

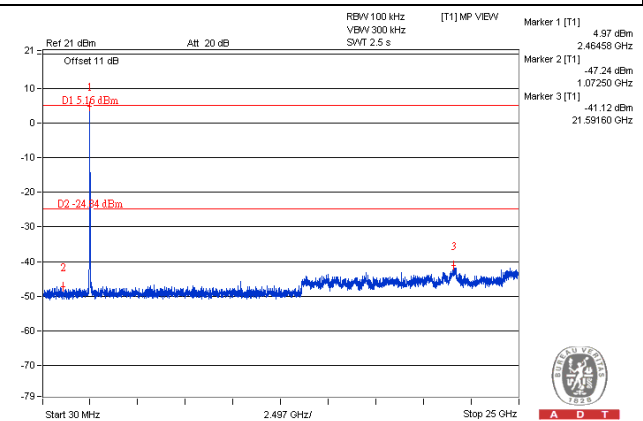
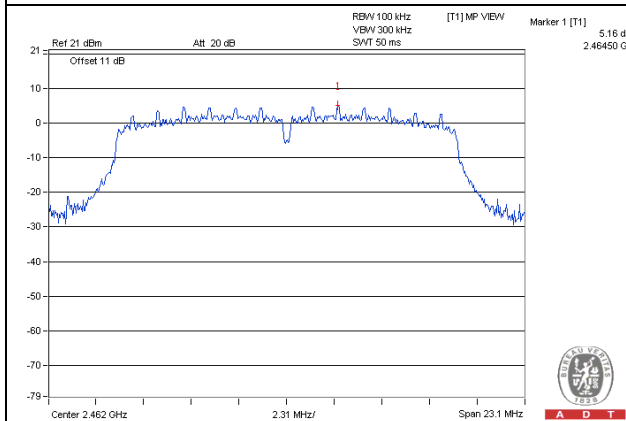

CH 1 Band edge

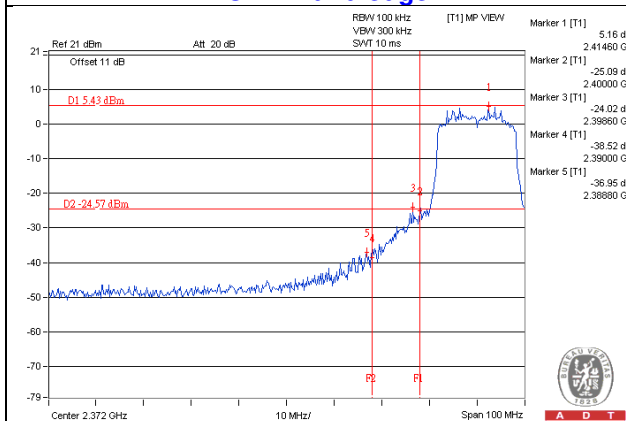

CH 11 Band edge

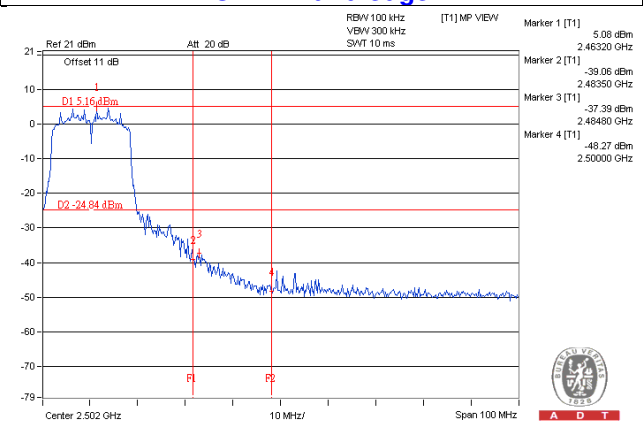

802.11n (20MHz)

CH 1

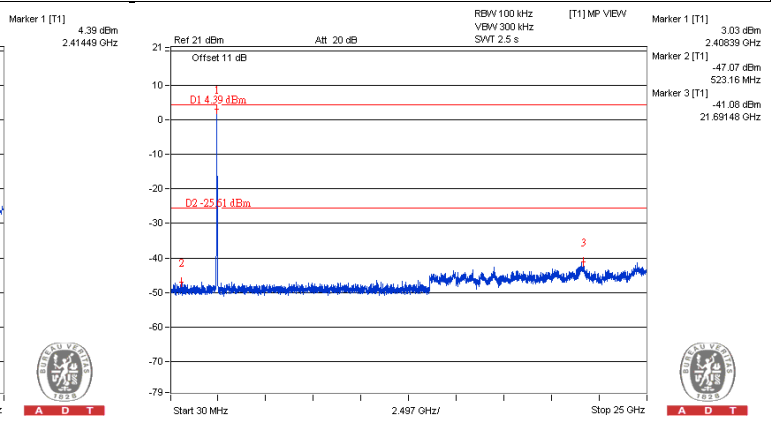
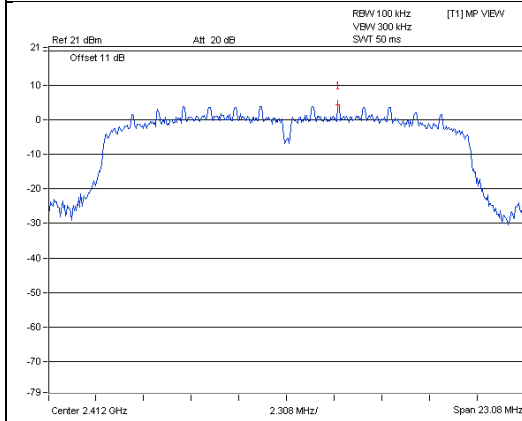

CH 6

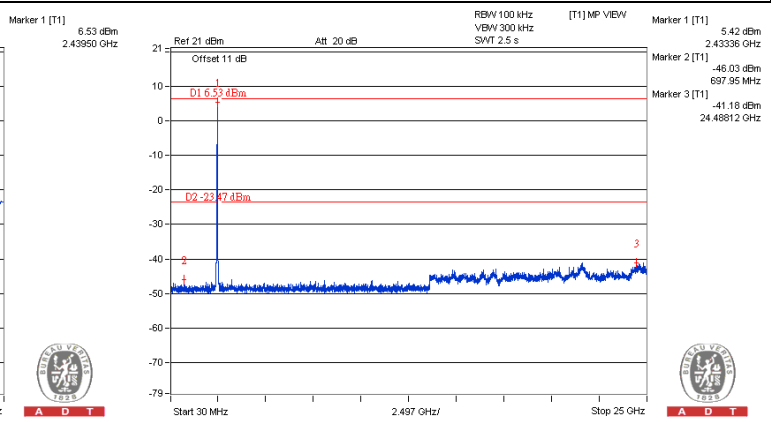
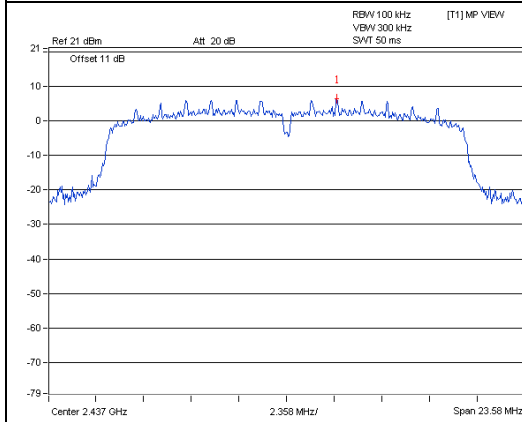

CH 11

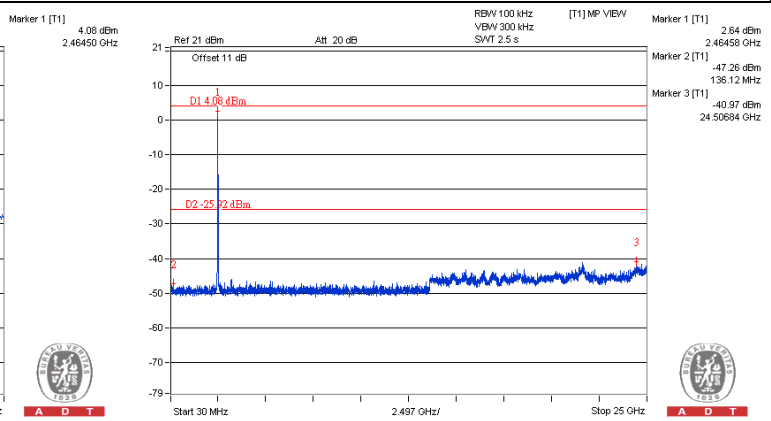
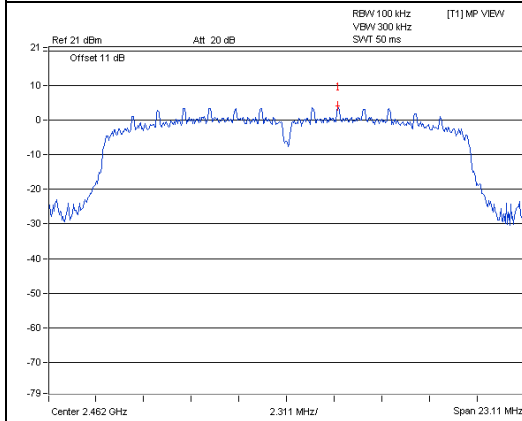

CH 1 Band edge

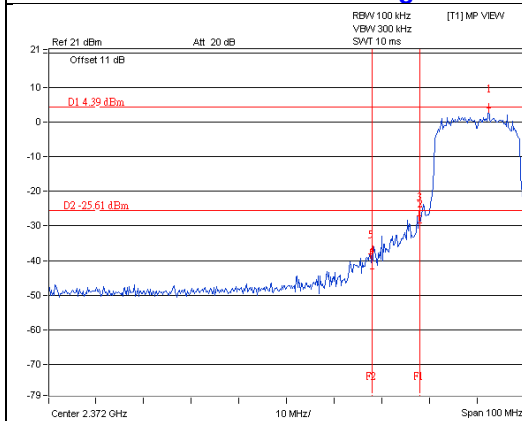

CH 11 Band edge

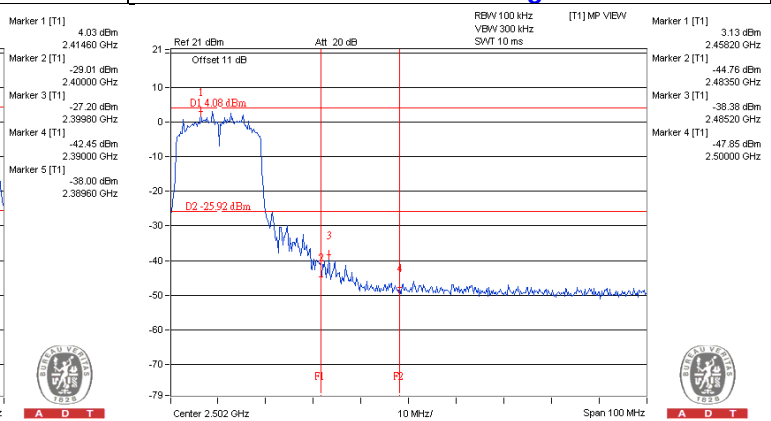

802.11n (40MHz)

CH 3

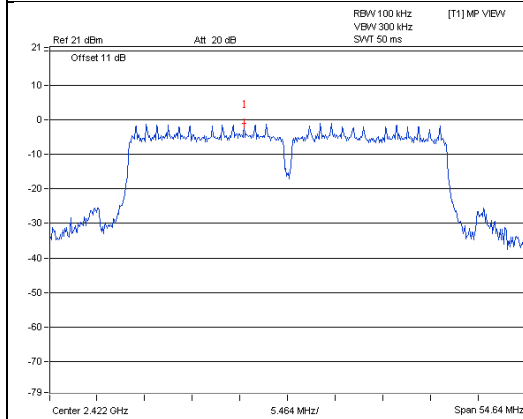

A D T

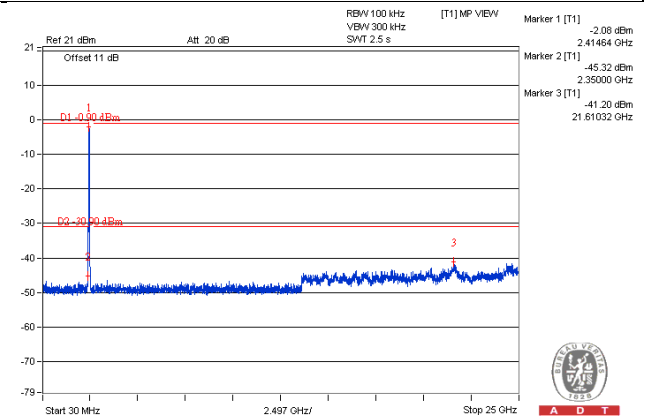

A D T

CH 6

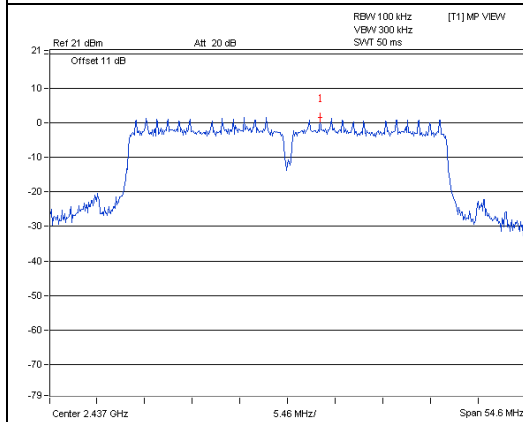

A D T

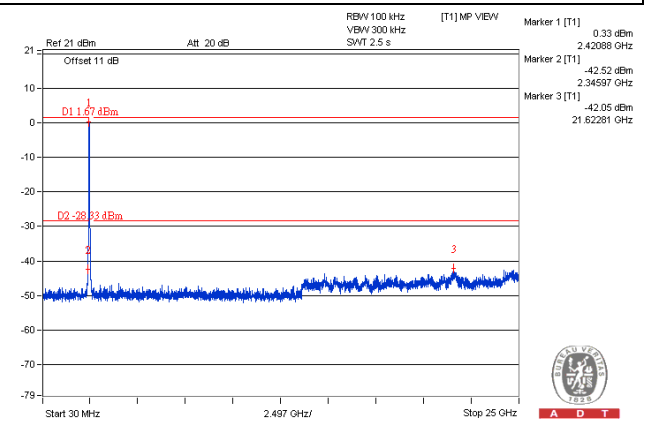

A D T

CH 9

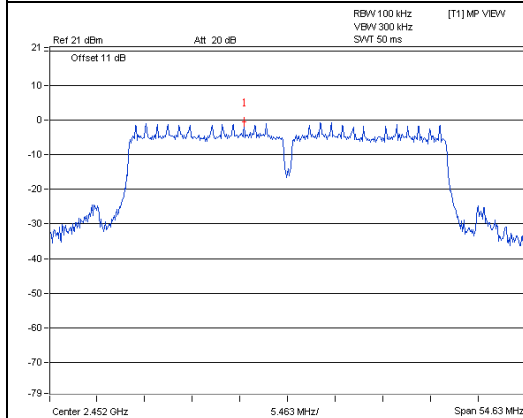

A D T

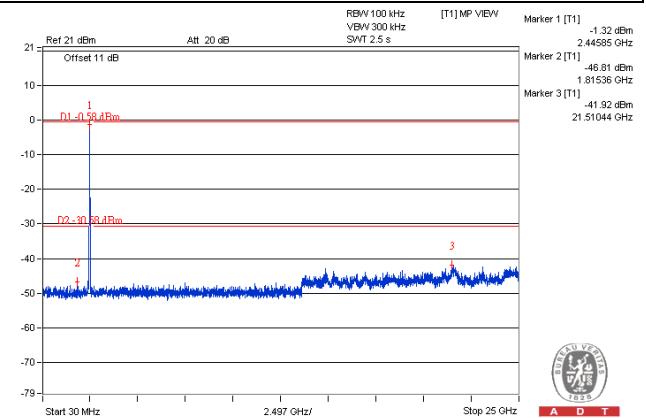

A D T

CH 3 Band edge

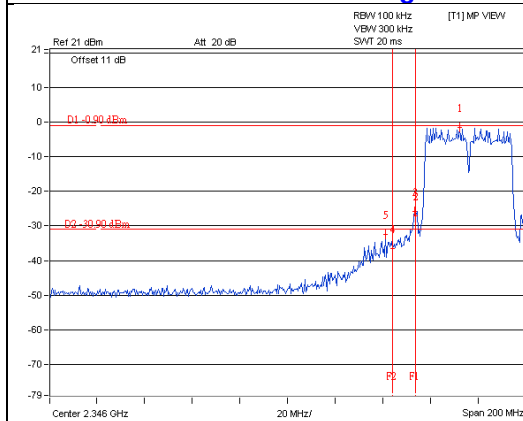

A D T

CH 9 Band edge

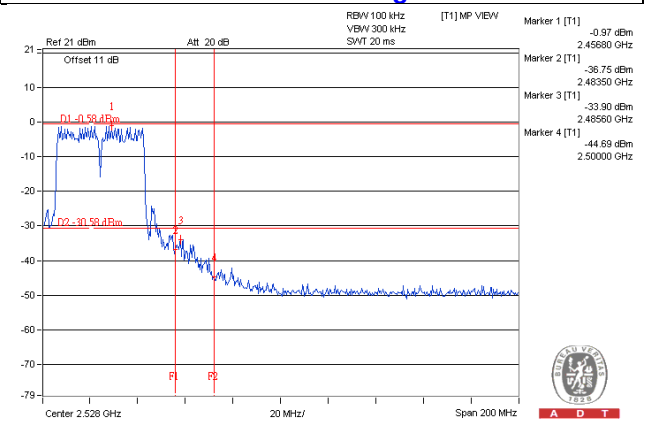

A D T

2TX 802.11g Chain 0

CH 1

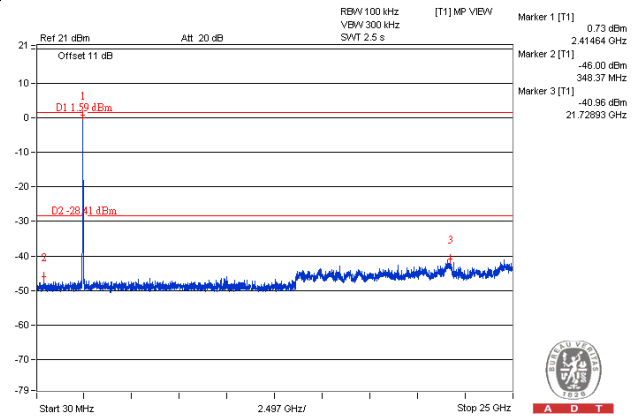
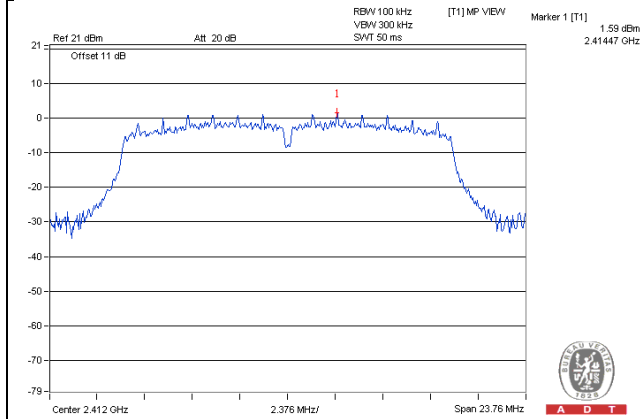

CH 6

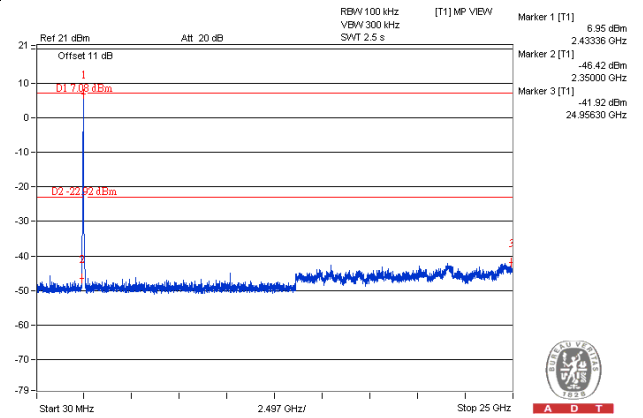
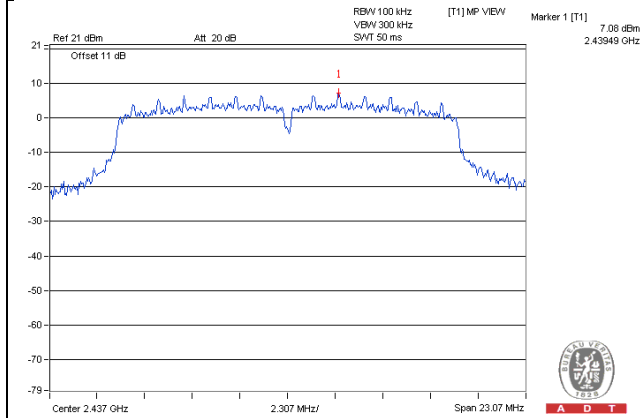

CH 11

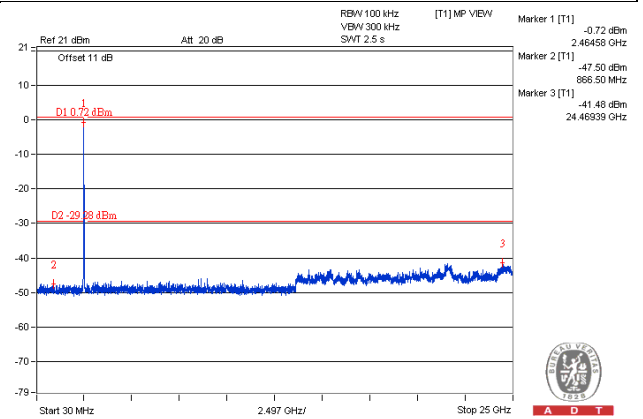
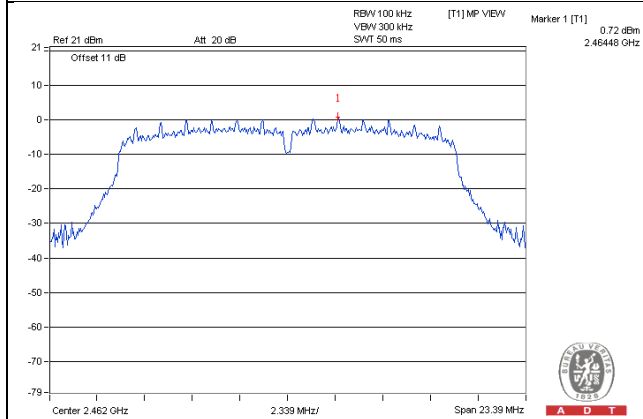

CH 1 Band edge

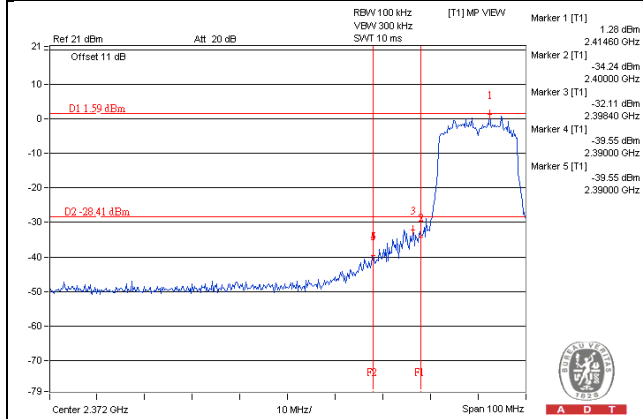

CH 11 Band edge

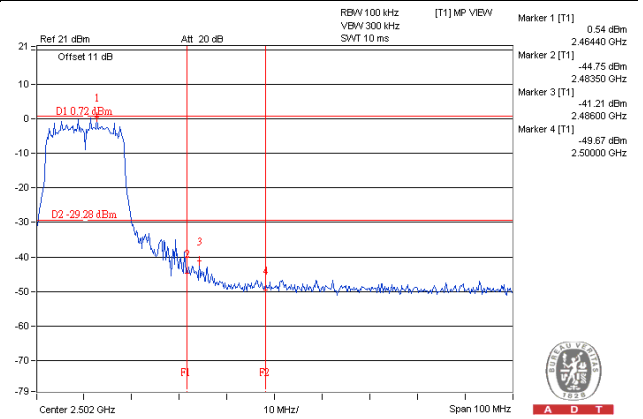

Chain 1

CH 1

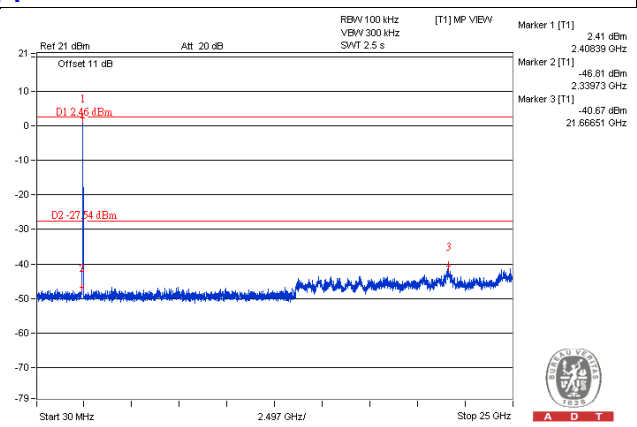
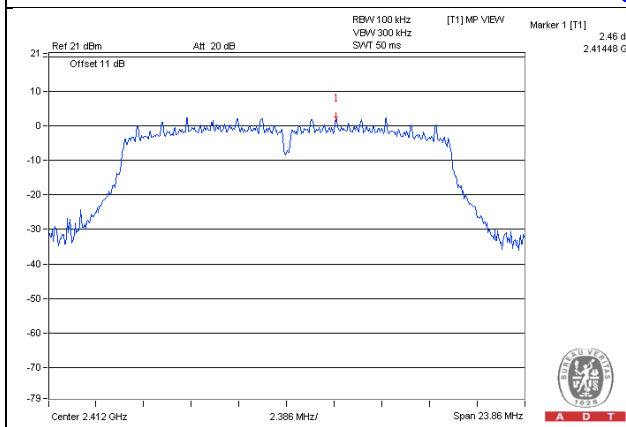

CH 6

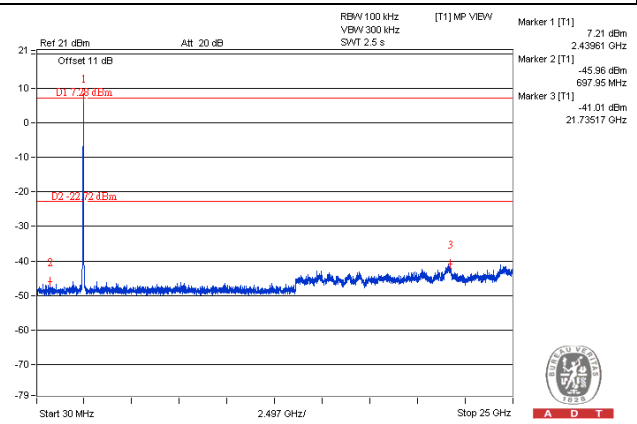
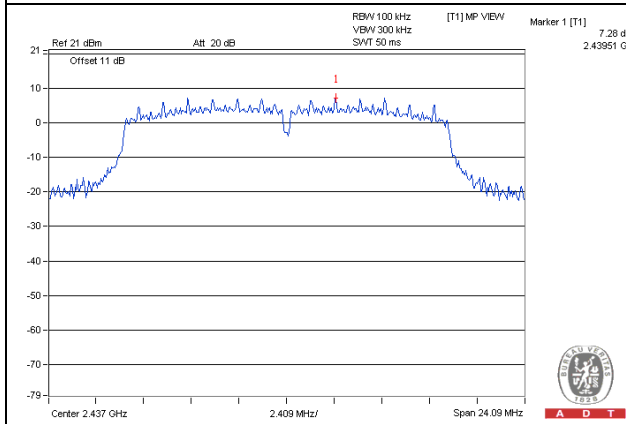

CH 11

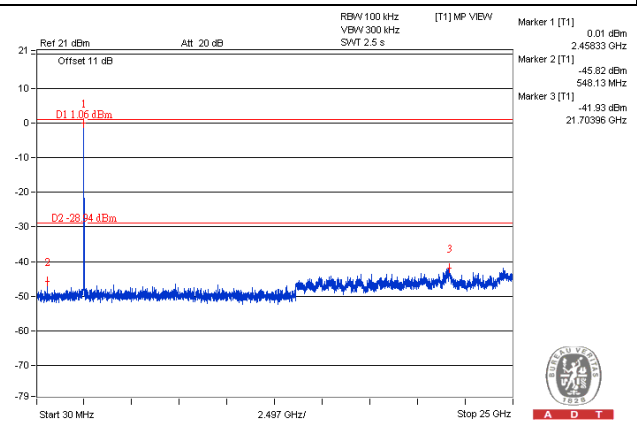
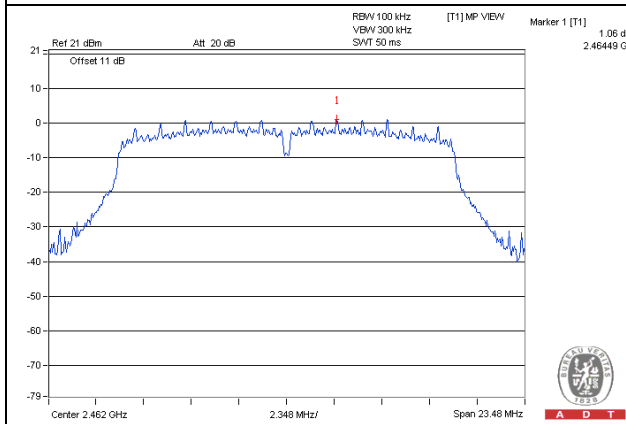

CH 1 Band edge

CH 11 Band edge

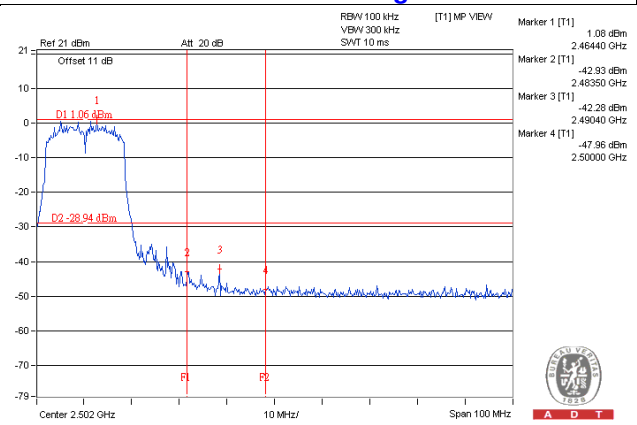
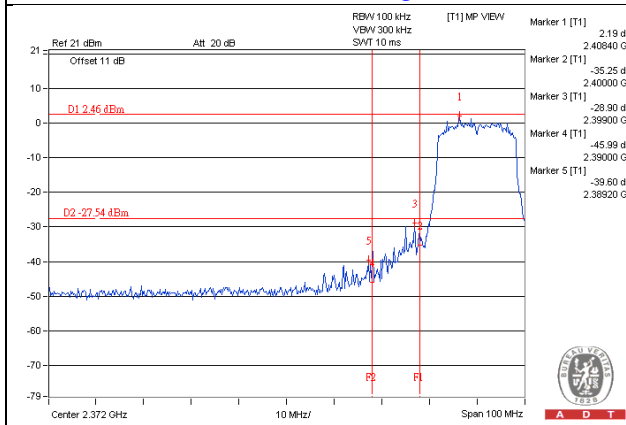

802.11n (20MHz) Chain 0

CH 1

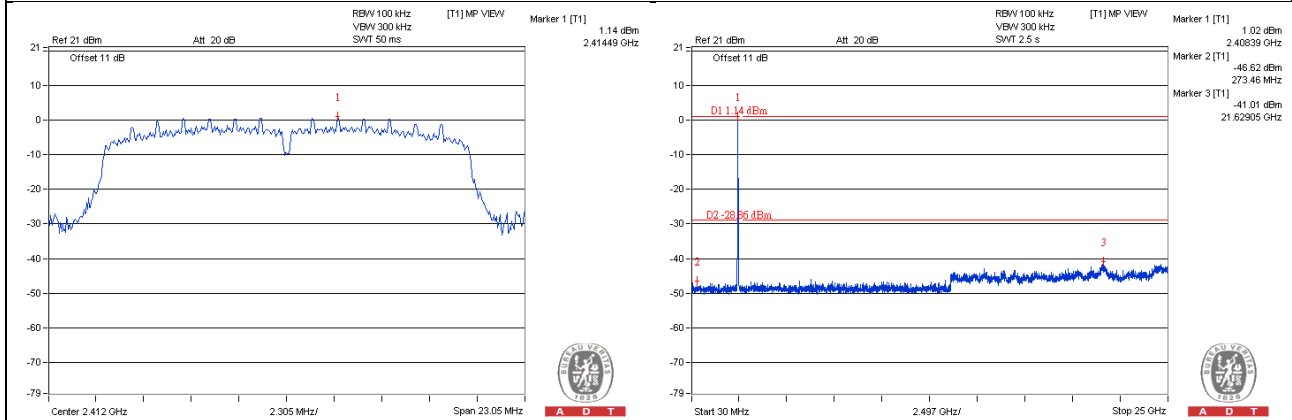

CH 6

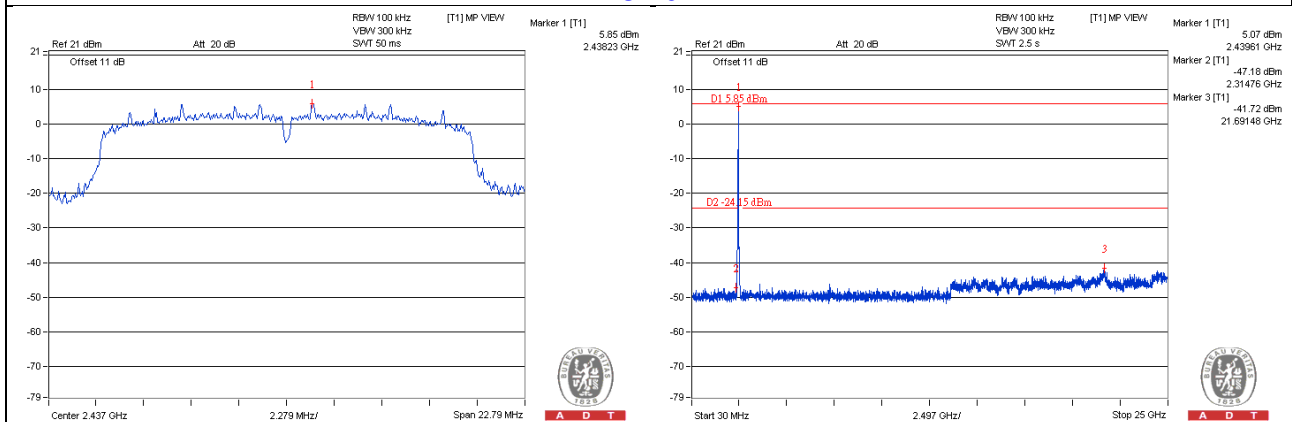

CH 11

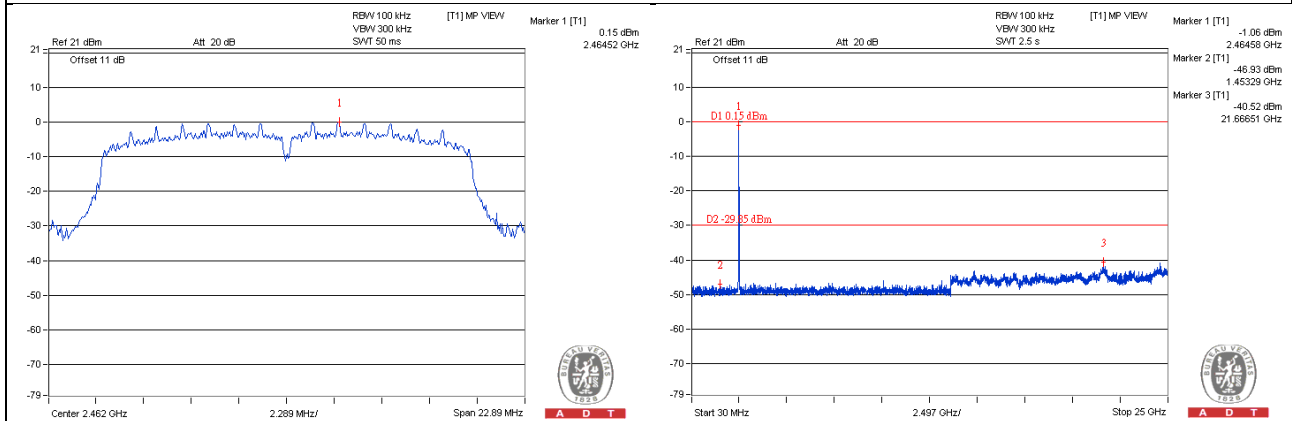

CH 1 Band edge

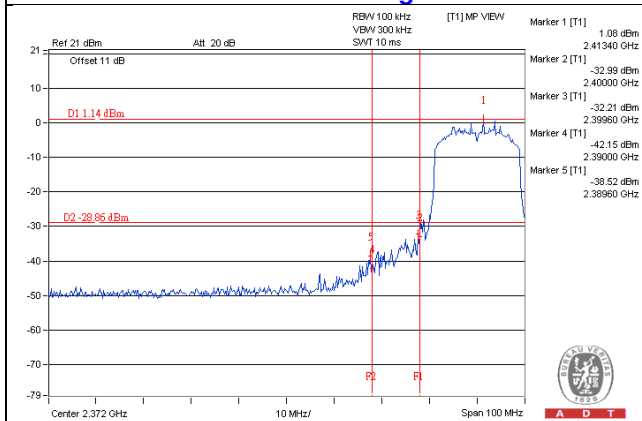

CH 11 Band edge

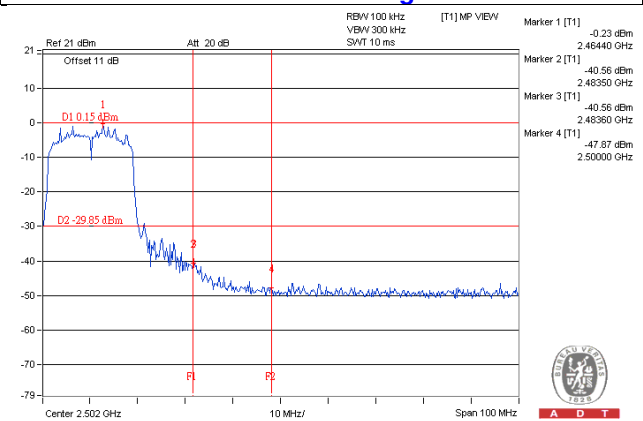

Chain 1

CH 1

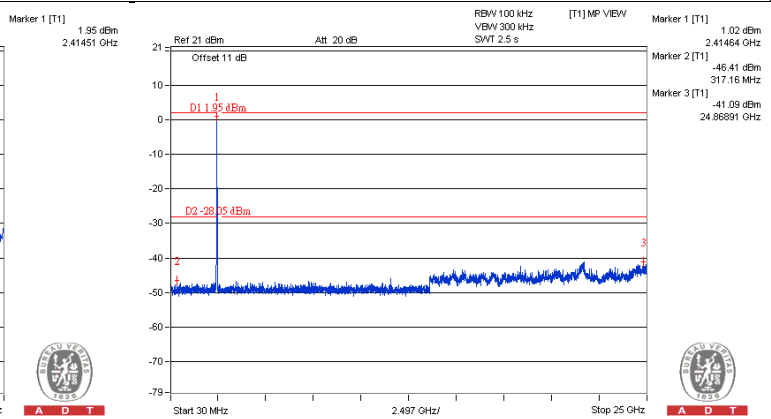
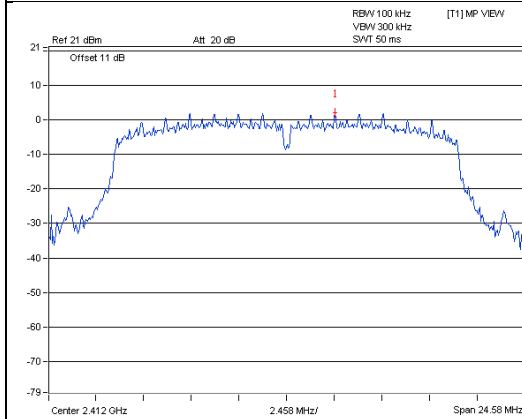

CH 6

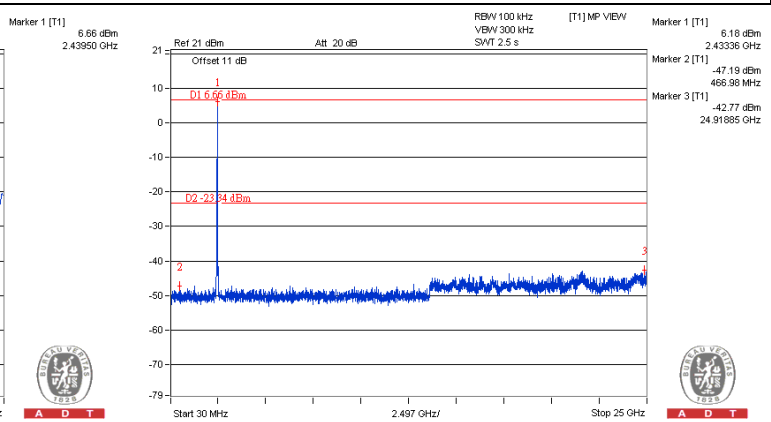
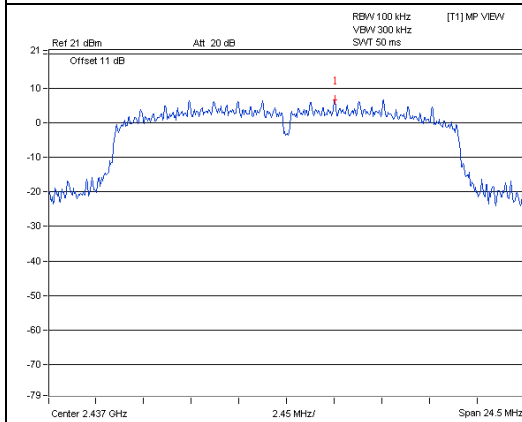

CH 11

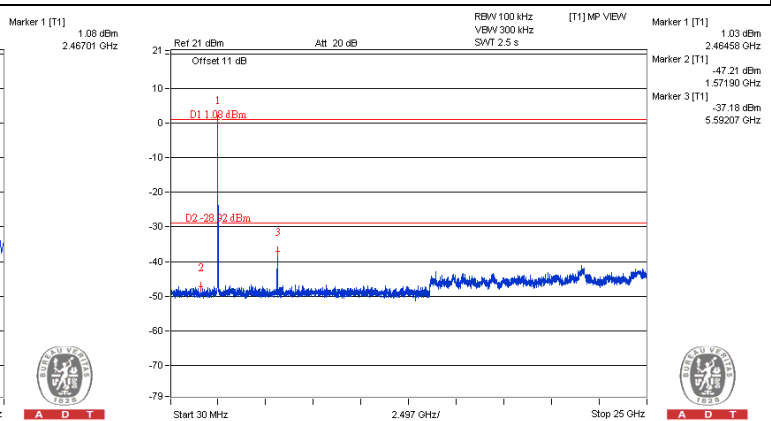
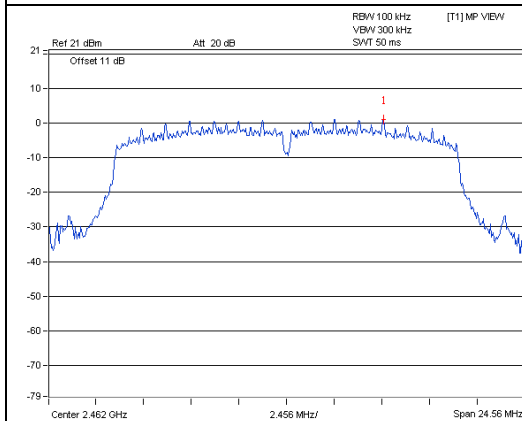

CH 1 Band edge

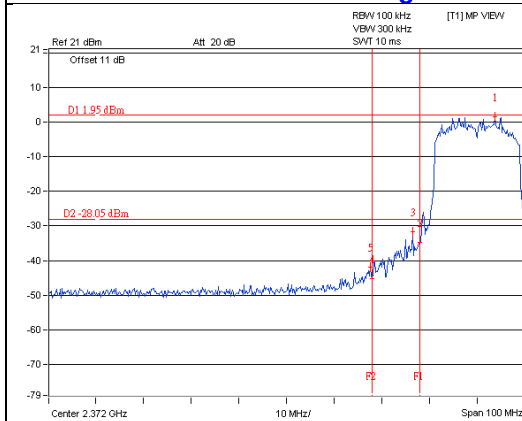

CH 11 Band edge

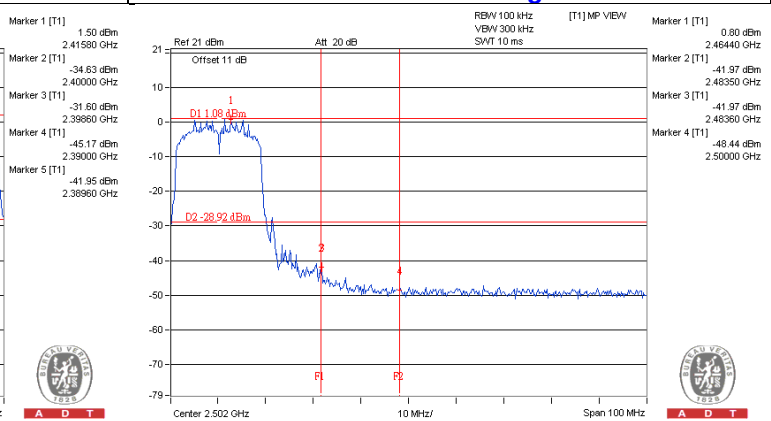

802.11n (40MHz) Chain 0

CH 3

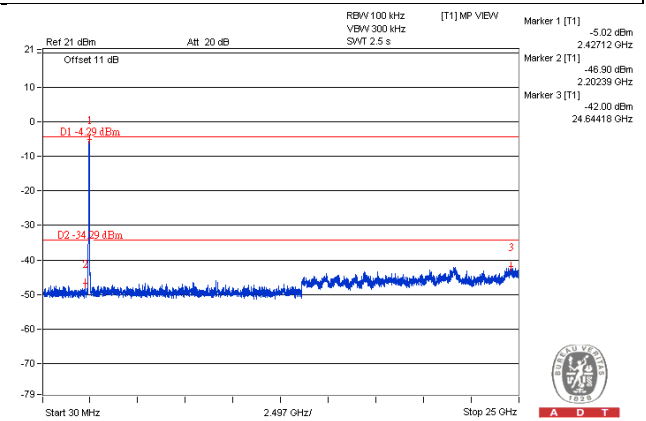
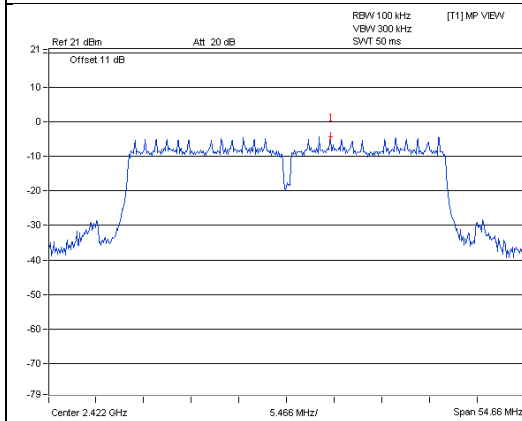

CH 6

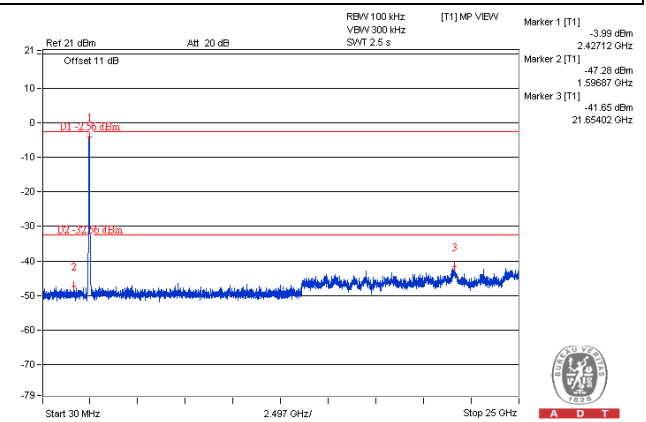
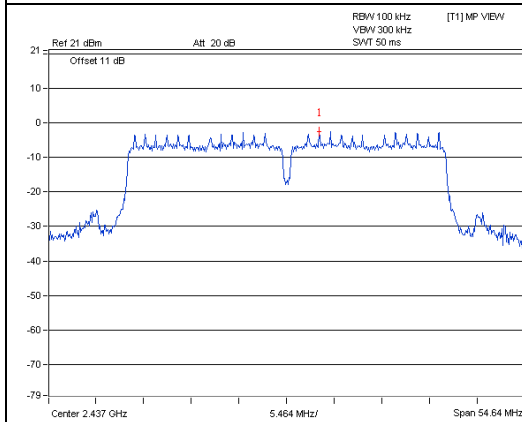

CH 9

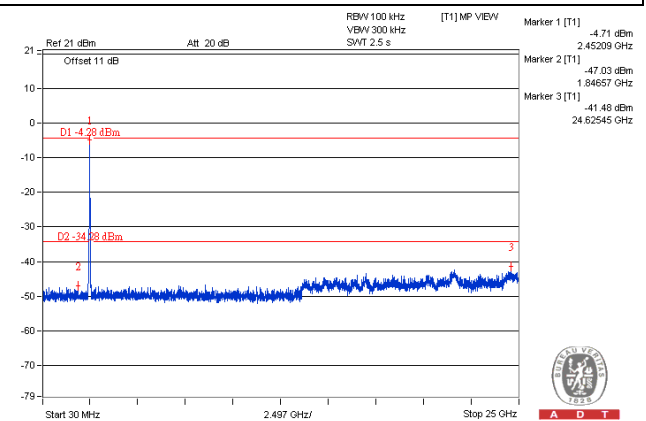
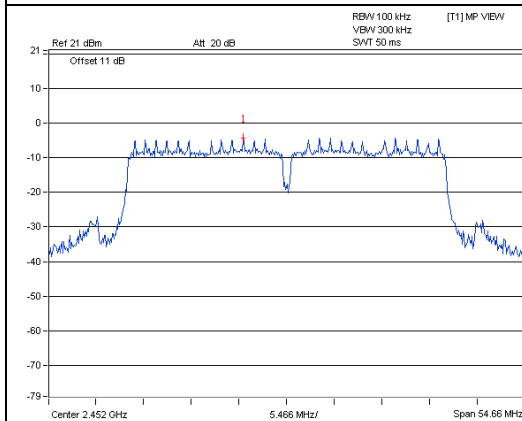

CH 3 Band edge

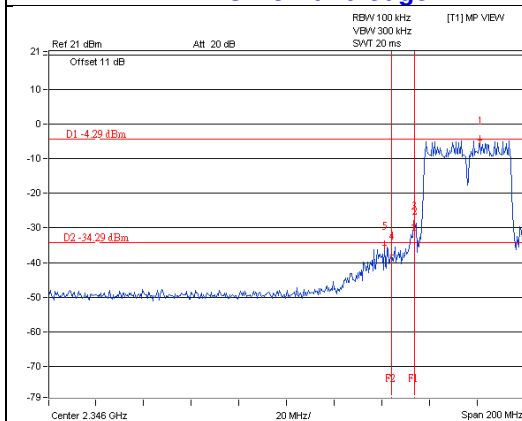

CH 9 Band edge

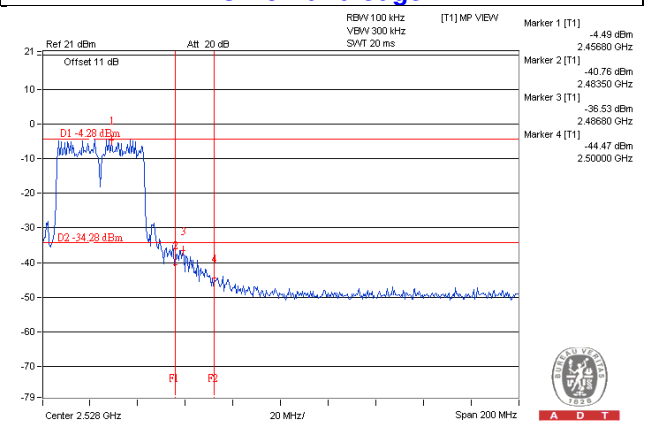

Chain 1

CH 3

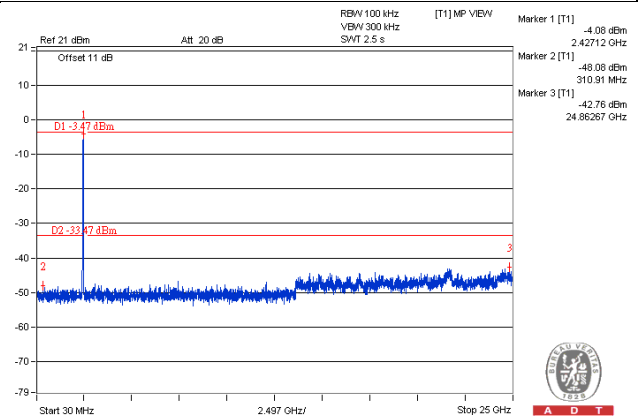
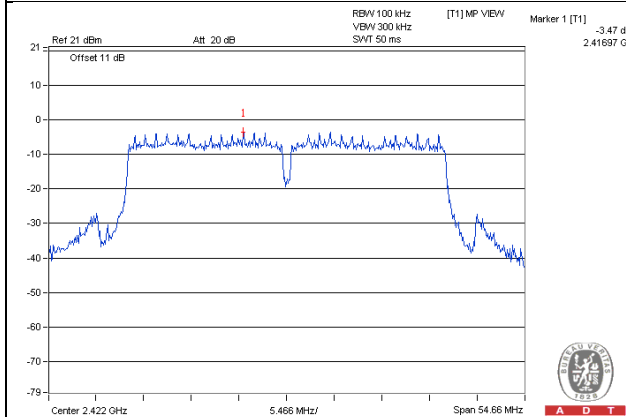

CH 6

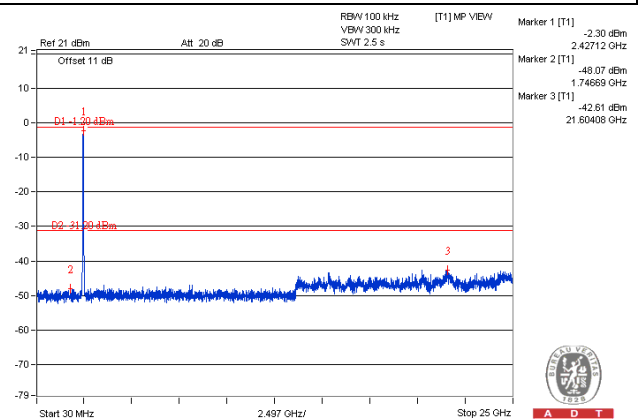
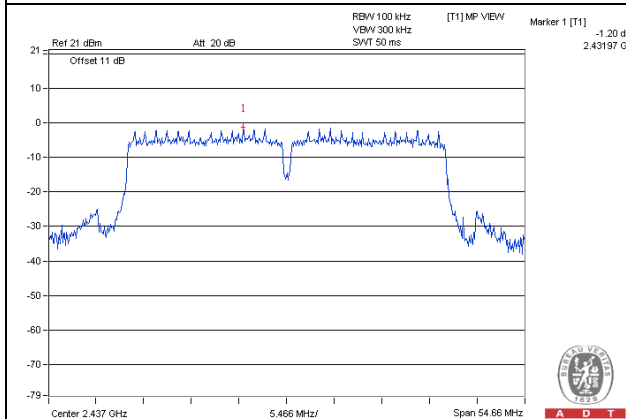

CH 9

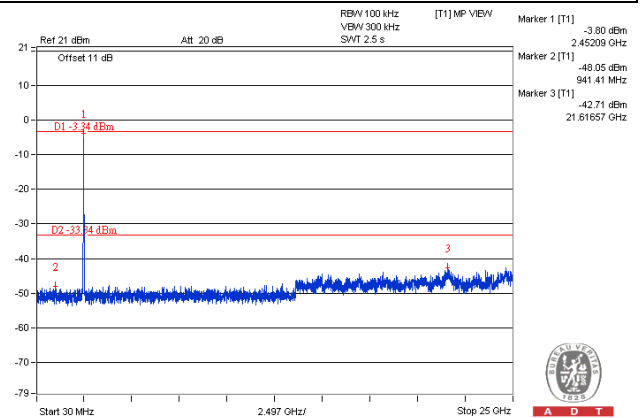
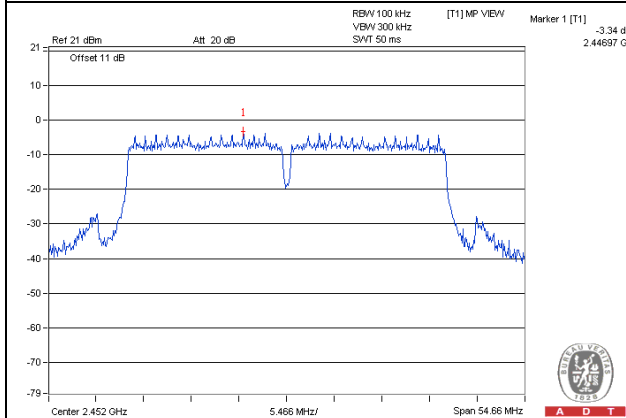

CH 3 Band edge

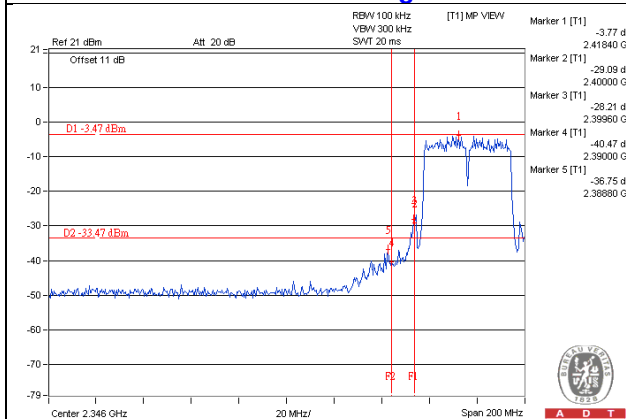

CH 9 Band edge

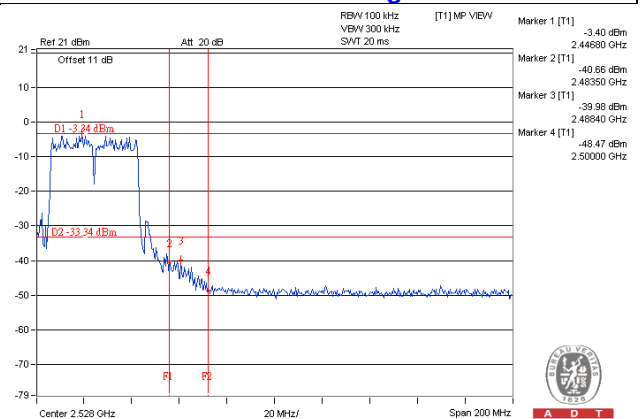

5 Pictures of Test Arrangements

Please refer to the attached file (Test Setup Photo).



Appendix – Information on the Testing Laboratories

We, Bureau Veritas Consumer Products Services (H.K.) Ltd., Taoyuan Branch, were founded in 1988 to provide our best service in EMC, Radio, Telecom and Safety consultation. Our laboratories are accredited and approved according to ISO/IEC 17025.

If you have any comments, please feel free to contact us at the following:

Linko EMC/RF Lab

Tel: 886-2-26052180

Fax: 886-2-26051924

Hsin Chu EMC/RF/Telecom Lab

Tel: 886-3-6668565

Fax: 886-3-6668323

Hwa Ya EMC/RF/Safety Lab

Tel: 886-3-3183232

Fax: 886-3-3270892

Email: service.adt@tw.bureauveritas.com

Web Site: www.bureauveritas-adt.com

The address and road map of all our labs can be found in our web site also.

--- END ---