



731 Enterprise Drive  
Lexington, KY 40510

Telephone: 859-226-1000  
Facsimile: 859-226-1040  
www.intertek-etlsemko.com

# TEST REPORT

**Report Number:** 100592399LEX-001  
**Project Number:** G100592399

**Report Issue Date:** 2/22/2012

**Product Name:** Wireless Control Tablet  
**Model Number:** TCA200  
**FCCID:** G95TCA200XX  
**ICID:** 431C-TCA200XX  
**FCC Standards:** FCC Part 22 Subpart H  
FCC Part 24 Subpart E

**Industry Canada Standards:** RSS-132 Issue 2  
RSS-133 Issue 5

Tested by:  
Intertek Testing Services NA, Inc.  
731 Enterprise Drive  
Lexington, KY 40510

Client:  
Technicolor USA, Inc.  
101 W 103rd Street  
Indianapolis, IN 46290

Report prepared by

Jason Centers, Senior Project Engineer

Report reviewed by

James Sudduth, Assistant Chief Engineer



*This report is for the exclusive use of Intertek's Client and is provided pursuant to the agreement between Intertek and its Client. Intertek's responsibility and liability are limited to the terms and conditions of the agreement. Intertek assumes no liability to any party, other than to the Client in accordance with the agreement, for any loss, expense or damage occasioned by the use of this report. Only the Client is authorized to permit copying or distribution of this report and then only in its entirety. Any use of the Intertek name or one of its marks for the sale or advertisement of the tested material, product or service must first be approved in writing by Intertek. The observations and test results in this report are relevant only to the sample tested. This report by itself does not imply that the material, product, or service is or has ever been under an Intertek certification program.*

**TABLE OF CONTENTS**

**1 Introduction and Conclusion..... 3**

**2 Test Summary ..... 3**

**3 Description of Equipment Under Test ..... 4**

**4 Conducted Output Power..... 7**

**5 Occupied Bandwidth ..... 10**

**6 Conducted Spurious Emissions at Antenna Terminals..... 13**

**7 Radiated Output Power ..... 35**

**8 Radiated Spurious Emissions (Transmitter)..... 36**

**9 Frequency Stability..... 42**

**10 Radiated Spurious Emissions (Receiver) ..... 45**

**11 Measurement Uncertainty..... 49**

**12 Revision History ..... 50**

## 1 Introduction and Conclusion

The tests indicated in Section 2 were performed on the product constructed as described in Section 3. The remaining test sections are the verbatim text from the actual data sheets used during the investigation. These test sections include the test name, the specified test method, a list of the actual test equipment used, documentation photos, results and raw data. No additions, deviations, or exclusions have been made from the standard(s) unless specifically noted.

Based on the results of our investigation, we have concluded the product tested complied with the requirements of the standard(s) indicated. The results obtained in this test report pertain only to the item(s) tested.

The INTERTEK-Lexington laboratory is located at 731 Enterprise Drive, Lexington Kentucky, 40510. The radiated emission test site is a 10-meter semi-anechoic chamber. The chamber meets the characteristics of CISPR 16-1 and ANSI C63.4. For measurements, a remotely controlled flush-mount metal-top turntable is used to rotate the EUT a full 360 degrees. A remote controlled non-conductive antenna mast is used to scan the antenna height from one to four meters. The test site is listed with the FCC under Registration Number 485103.

## 2 Test Summary

Page	Test full name	FCC Reference	Industry Canada	Result
7	Conducted Output Power	§2.1046 §24.232(d)	RSS-132 (4.4), RSS-133 (4.1), RSS-133 (6.4)	Pass
10	Occupied Bandwidth	§2.1049, §22.917(b)(d), and §24.238(a)	RSS-GEN (4.6.1), RSS-133 (2.3)	Pass
13	Conducted Spurious Emissions	§2.1049, §2.1051, §22.917(a)(b), and § 24.238(a)(b)	RSS-132 (4.5), RSS-133 (6.5.1)	Pass
35	Radiated Output Power	§ 22.913(a) and § 24.232(c)	RSS-132 (4.4), RSS-133 (6.4)	Pass
36	Radiated Spurious Emissions (Transmitter)	§2.1053, §22.917(a)(b), and §24.238(a)(b)	RSS-132 (4.5), RSS-133 (6.5)	Pass
42	Frequency Stability	§2.1055, §22.355, and §24.235	RSS-132 (4.3), RSS-133 (6.3)	Pass
45	Radiated Spurious Emissions (Receiver)	---	RSS-132 (4.6), RSS-133 (6.6), RSS-GEN (4.10)	Pass

**3 Description of Equipment Under Test**

<b>Equipment Under Test</b>	
<b>Manufacturer</b>	Technicolor USA, Inc.
<b>Model Number</b>	TCA200
<b>Serial Number</b>	TCA200150010100413
<b>FCC Identifier</b>	G95TCA200XX
<b>IC Identifier</b>	431C-TCA200XX
<b>Receive Date</b>	1/3/2012
<b>Test Start Date</b>	2/3/2012
<b>Test End Date</b>	2/10/2012
<b>Device Received Condition</b>	Good
<b>Test Sample Type</b>	Production
<b>Frequency Band</b>	824MHz - 849MHz (GSM 850 Band) 1850MHz - 1910MHz (GSM 1900 Band)
<b>Modulation Type</b>	GSM (GMSK), GPRS (GMSK), EDGE (8-PSK)
<b>Transmission Control</b>	Base Station Simulator
<b>Maximum Output Power (Conducted)</b>	32.17 dBm (GSM 850 - GMSK) 29.04dBm (GSM 1900 - GMSK) 26.22 dBm (GSM 850 - 8-PSK) 25.58dBm (GSM 1900 - 8-PSK)
<b>Test Channels</b>	128, 190, & 251 (GSM 850 Band) 512, 661, & 810 (GSM 1900 Band)
<b>Antenna Type</b>	Internal
<b>Operating Voltage</b>	115VAC/60Hz
<b>Power Supply</b>	AC Bel, Model: WAA019, Sn: V123400271

**Description of Equipment Under Test**

The TCA200 is a touch screen alarm panel that contains a zigbee, 802.11b/g/n, and cellular modules. This report contains data for the cellular module.

**Operating modes of the EUT:**

<b>No.</b>	<b>Descriptions of EUT Exercising</b>
1	Transmitting a GSM signal
2	Receive / idle mode

**3.1 System setup including cable interconnection details, support equipment and simplified block diagram**

**3.2 EUT Block Diagram:**



Block Diagram for Radiated Tests

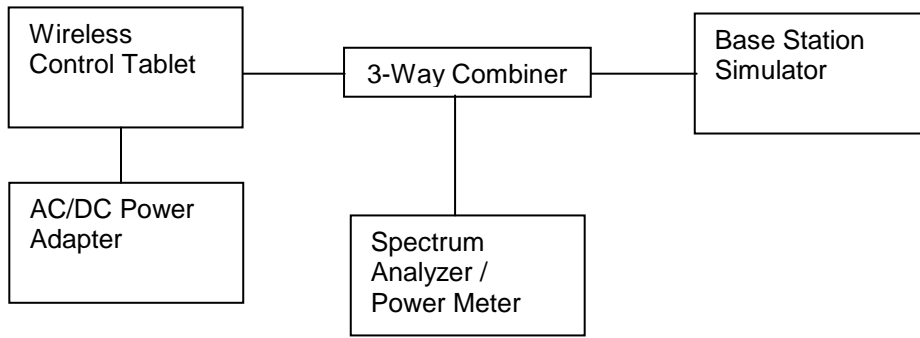

Block Diagram for Conducted Tests at the Antenna Port

**3.3 Cables:**

Cables					
Description	Length	Shielding	Ferrites	Connection	
				From	To
Power Cable	6 ft	No	Yes	AC/DC Power Converter	DC Input
Ethernet Cable	25 ft	No	No	Ethernet Port	Ethernet Switch
Speaker Cable	3 ft	No	No	Headphone Port	Headphones

**3.4 Support Equipment:**

No support equipment was necessary for the evaluation.

## 4 Conducted Output Power

### 4.1 Test Limits

#### § 2.1046

For transmitters other than single sideband, independent sideband and controlled carrier radiotelephone, power output shall be measured at the RF output terminals when the transmitter is adjusted in accordance with the tune-up procedure to give the values of current and voltage on the circuit elements specified in §2.1033(c)(8).

#### § 24.232 (d)

Power measurements for transmissions by stations authorized under this section may be made either in accordance with a Commission-approved average power technique or in compliance with paragraph (e) of this section. In both instances, equipment employed must be authorized in accordance with the provisions of §24.51. In measuring transmissions in this band using an average power technique, the peak-to-average ratio (PAR) of the transmission may not exceed 13 dB.

### 4.2 Test Procedure

The transmitter output was connected to a coaxial cable, the other end of which was connected to a Base Station Simulator. The Base Station Simulator was set to force the EUT to its maximum power setting. The EUT was placed into a call and the burst average power was measured with a power meter dBm. The power output at the transmitter antenna port was determined by adding the value of the cable insertion loss to the power reading. Tests were performed at three frequencies (low, middle, and high channels) and on the highest power levels, which can be setup on the transmitters.

The peak-to-average ratio (PAR) was measured using a spectrum analyzer with a RBW wider than the EBW of the measured signal. The delta between the peak and average trace was recorded.

### 4.3 Test Equipment Used:

Description	Serial Number	Manufacturer	Model	Cal. Date	Cal. Due
Base Station Simulator	2522	Rohde & Schwarz	CMU200	9/30/2011	9/30/2012
Environmental Chamber	29410	Thermotron	SE-1000-5-5	4/6/2011	4/6/2012
Spectrum Analyzer	3099	Rohde & Schwarz	FSP7	9/23/2012	9/23/2012
Power Meter	3166	Gigatronics	8541C	9/23/2011	9/23/2012
Power Sensor	3404	Gigatronics	80601A	9/23/2011	9/23/2012
RF Combiner	E18106	Weinschel Engineering	1506A	Time of Use	Time of Use
Directional Coupler	08736	Narda	4226-20	Time of Use	Time of Use

**4.4 Results:**

**Conducted Output Power at Nominal Temperature**

Band	Channel	Frequency (MHz)	Burst Average Power (dBm)								
			GSM	GPRS - 1 Tx Slot	GPRS - 2 Tx Slots	GPRS - 3 Tx Slots	GPRS - 4 Tx Slots	EDGE - 1 Tx Slot	EDGE - 2 Tx Slots	EDGE - 3 Tx Slots	EDGE - 4 Tx Slots
GSM 850	128	824.2	32.04	32.17	32.11	32.05	31.98	26.1	26.22	26.2	26.14
	190	836.6	31.89	32.04	31.99	31.91	31.85	25.9	26.15	26.1	26.02
	251	848.8	31.73	31.88	31.85	31.74	31.69	25.7	25.8	25.9	25.88
GSM 1900	512	1850.2	28.92	29.04	29	28.97	29.01	25.46	25.58	25.5	25.45
	661	1880	28.6	28.8	28.82	28.73	28.78	25.25	25.3	25.2	25.2
	810	1909.8	28.48	28.6	28.6	28.51	28.58	25.06	25.12	25.02	25.02

**Conducted Output Power at Temperature and Voltage Extremes**

Configuration	Temp	Input Voltage (VAC)	Burst Average Power (dBm)		
			Ch. 128	Ch. 190	Ch. 251
GSM850 - GPRS 1Tx Slot	-30	115	32	31.9	31.8
	20	115	32.1	32.1	31.8
	20	138	32.1	32.1	31.8
	20	93.5	32.1	32.1	31.8
	60	115	32	31.9	31.7

Configuration	Temp	Input Voltage (VAC)	Burst Average Power (dBm)		
			Ch. 128	Ch. 190	Ch. 251
GSM850 - EDGE 1Tx Slot	-30	115	25.3	25.3	25.1
	20	115	26.4	26.2	26
	20	138	26.3	26.2	26
	20	93.5	26.3	26.2	26
	60	115	26.2	26.1	25.9

Configuration	Temp	Input Voltage (VAC)	Burst Average Power (dBm)		
			Ch. 512	Ch. 661	Ch. 810
GSM1900 - GPRS 1Tx Slot	-30	115	18.7	18.5	18.4
	20	115	28.5	28.4	28.3
	20	138	28.5	28.4	28.3
	20	93.5	28.5	28.4	28.3
	60	115	28.5	28.4	28.3

Configuration	Temp	Input Voltage (VAC)	Burst Average Power (dBm)		
			Ch. 512	Ch. 661	Ch. 810
GSM1900 - EDGE 1Tx Slot	-30	115	23.7	23.5	23.4
	20	115	24.7	24.6	24.6
	20	138	24.7	24.5	24.6
	20	93.5	24.7	24.6	24.6
	60	115	24.5	24.4	24.4



### Peak-to-Average Ratio - GPRS Mode

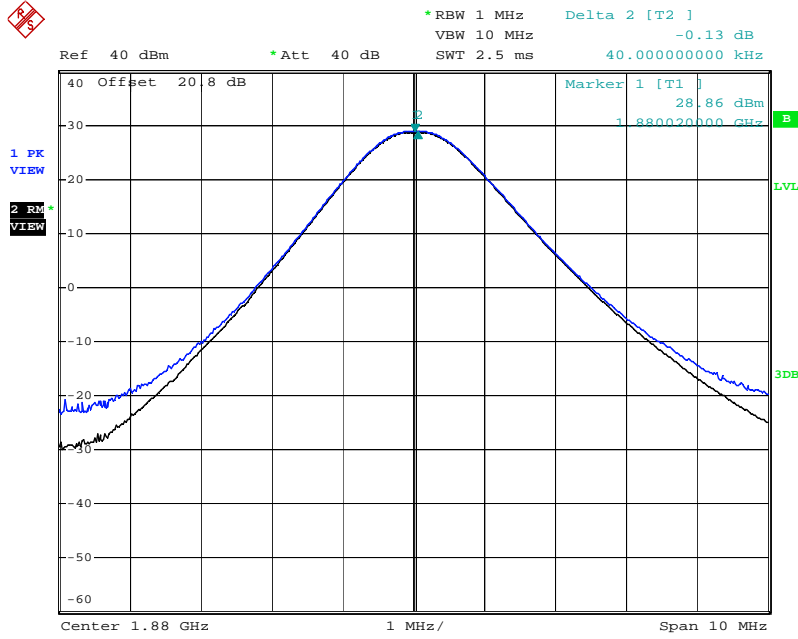

Date: 4.FEB.2012 16:30:55

### Peak-to-Average Ratio - EDGE Mode

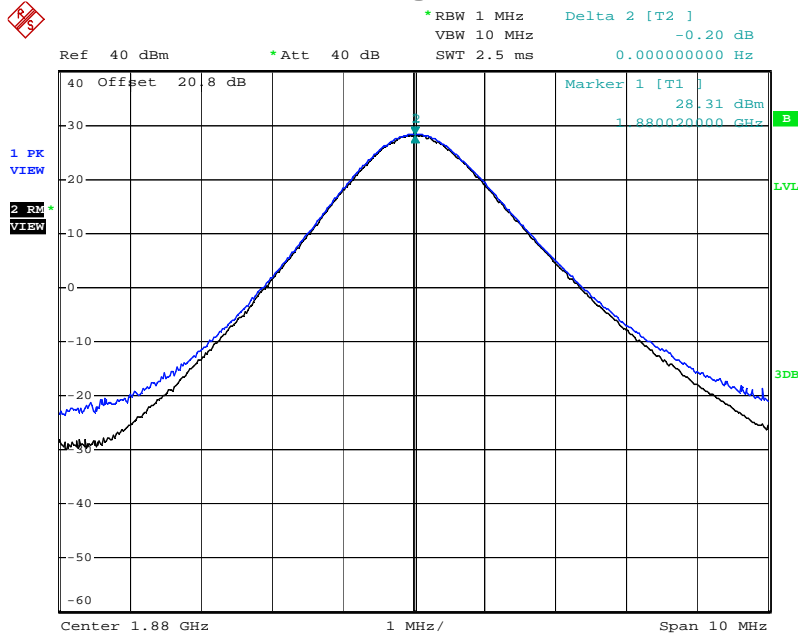

Date: 4.FEB.2012 16:25:20

## 5 Occupied Bandwidth

### 5.1 Test Limits

#### §2.1049:

The occupied bandwidth is the frequency bandwidth such that, below its lower and above its upper frequency limits, the mean powers radiated are each equal to 0.5 percent of the total mean power radiated by a given emission.

### 5.2 Test Procedure

The EUT was connected to a spectrum analyzer using a coaxial cable and power divider. The EUT was placed into a call using base station simulator. The base station simulator was set to force the EUT to its maximum power setting. The occupied bandwidth function of the analyzer was used to automatically generate the occupied bandwidth plots below.

### 5.3 Test Equipment Used:

Description	Serial Number	Manufacturer	Model	Cal. Date	Cal. Due
Spectrum Analyzer	3099	Rohde & Schwarz	FSP7	9/23/2012	9/23/2012
Base Station Simulator	2522	Rohde & Schwarz	CMU200	9/30/2011	9/30/2012
Base Station Simulator	3101	Rohde & Schwarz	CMU200	6/1/2011	6/1/2012
Directional Coupler	08736	Narda	4226-20	Time of Use	Time of Use

5.4 Results:

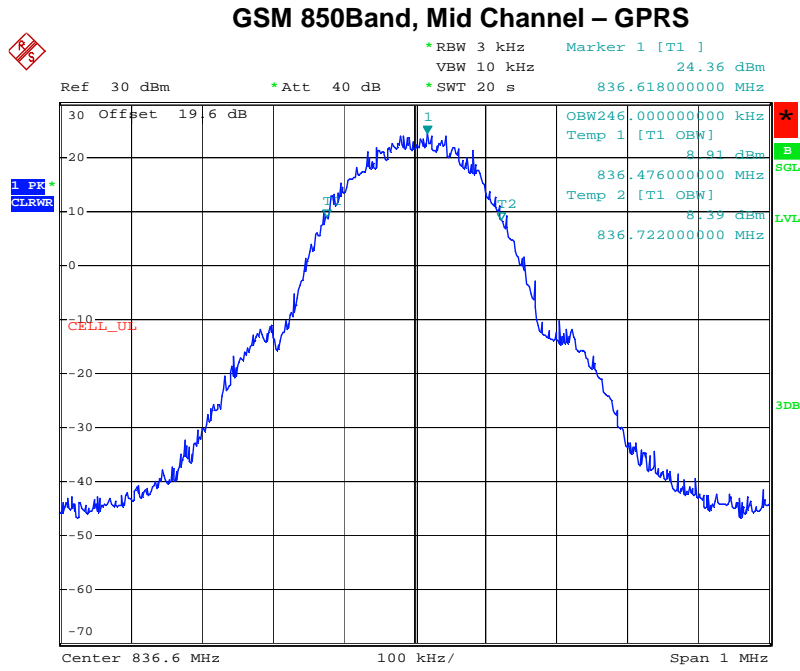

Date: 4.FEB.2012 15:11:02

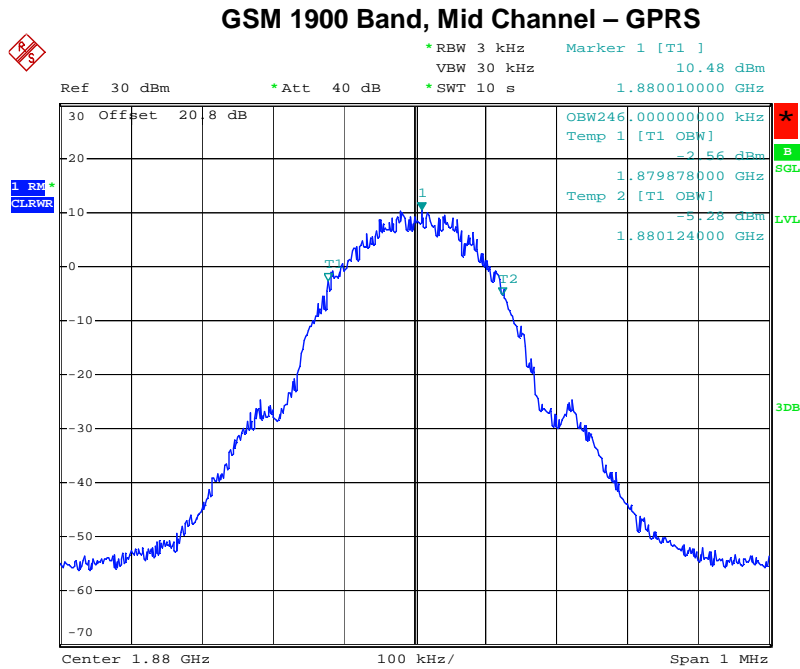

Date: 4.FEB.2012 16:37:33

GSM 850Band, Mid Channel – EDGE

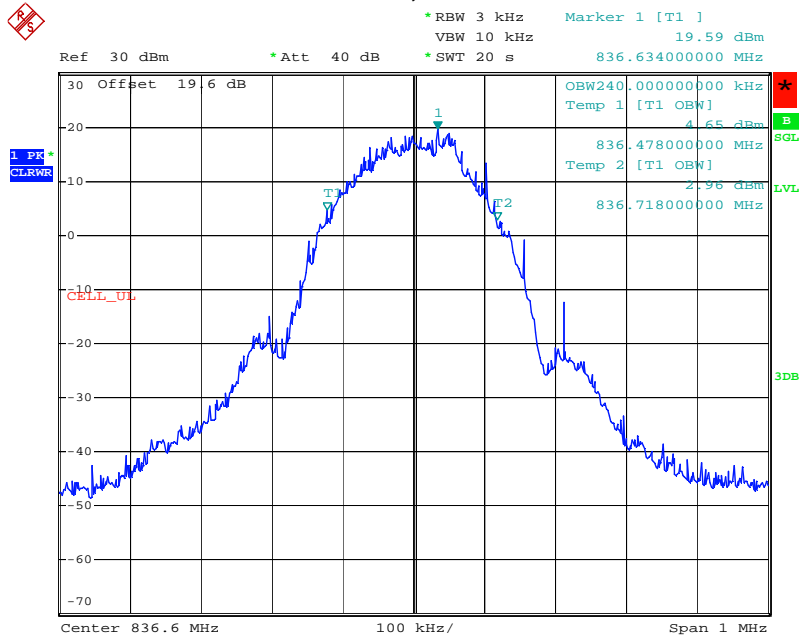

Date: 4.FEB.2012 15:16:05

GSM 1900 Band, Mid Channel – EDGE

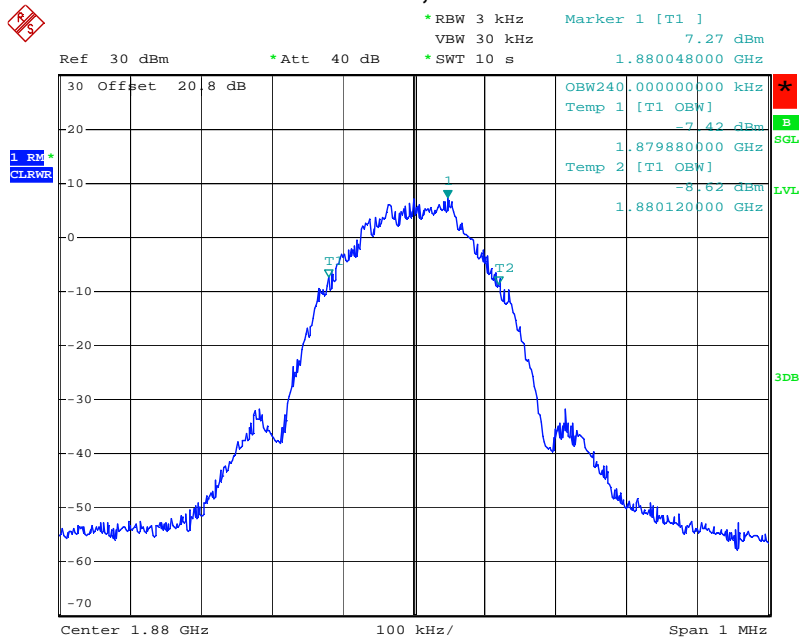

Date: 4.FEB.2012 16:19:21

## 6 Conducted Spurious Emissions at Antenna Terminals

### 6.1 Test Limits

#### § 2.1049

The occupied bandwidth, that is the frequency bandwidth such that, below its lower and above its upper frequency limits, the mean powers radiated are each equal to 0.5 percent of the total mean power radiated by a given emission shall be measured under the following conditions as applicable:

- (h) Transmitters employing digital modulation techniques—when modulated by an input signal such that its amplitude and symbol rate represent the maximum rated conditions under which the equipment will be operated. The signal shall be applied through any filter networks, pseudo-random generators or other devices required in normal service. Additionally, the occupied bandwidth shall be shown for operation with any devices used for modifying the spectrum when such devices are optional at the discretion of the user.

#### § 2.1051

The radio frequency voltage or powers generated within the equipment and appearing on a spurious frequency shall be checked at the equipment output terminals when properly loaded with a suitable artificial antenna. Curves or equivalent data shall show the magnitude of each harmonic and other spurious emission that can be detected when the equipment is operated under the conditions specified in §2.1049 as appropriate. The magnitude of spurious emissions which are attenuated more than 20 dB below the permissible value need not be specified.

#### § 22.917

- (a) Out of band emissions. The power of any emission outside of the authorized operating frequency ranges must be attenuated below the transmitting power (P) by a factor of at least  $43 + 10 \log(P)$  dB.
- (b) Measurement procedure. Compliance with these rules is based on the use of measurement instrumentation employing a resolution bandwidth of 100 kHz or greater. In the 1 MHz bands immediately outside and adjacent to the frequency block a resolution bandwidth of at least one percent of the emission bandwidth of the fundamental emission of the transmitter may be employed. A narrower resolution bandwidth is permitted in all cases to improve measurement accuracy provided the measured power is integrated over the full required measurement bandwidth ( i.e. 100 kHz or 1 percent of emission bandwidth, as specified). The emission bandwidth is defined as the width of the signal between two points, one below the carrier center frequency and one above the carrier center frequency, outside of which all emissions are attenuated at least 26 dB below the transmitter power.

#### § 24.238

- (a) Out of band emissions. The power of any emission outside of the authorized operating frequency ranges must be attenuated below the transmitting power (P) by a factor of at least  $43 + 10 \log(P)$  dB.
- (b) Measurement procedure. Compliance with these rules is based on the use of measurement instrumentation employing a resolution bandwidth of 1 MHz or greater. However, in the 1 MHz bands immediately outside and adjacent to the frequency block a resolution bandwidth of at least one percent of the emission bandwidth of the fundamental emission of the transmitter may be employed. A narrower resolution bandwidth is permitted in all cases to improve measurement accuracy provided the measured power is integrated over the full required measurement bandwidth ( i.e. 1 MHz or 1 percent of emission bandwidth, as specified). The emission bandwidth is defined as the width of the signal between two points, one below the carrier center frequency and one above the carrier center frequency, outside of which all emissions are attenuated at least 26 dB below the transmitter power.

**6.2 Test Procedure**

The RF output of the EUT was connected to a spectrum analyzer through appropriate attenuation. The base station simulator was set to force the EUT to its maximum power setting. The resolution bandwidth of the spectrum analyzer was set at 100kHz or 1MHz depending on the transmit band. Sufficient scans were taken to show the out of band Emissions if any up to 10th harmonic.

**6.3 Test Equipment Used:**

Description	Serial Number	Manufacturer	Model	Cal. Date	Cal. Due
Spectrum Analyzer	3099	Rohde & Schwarz	FSP7	9/23/2012	9/23/2012
EMC Analyzer	2142	HP	E7405	9/23/2011	9/23/2012
Base Station Simulator	2522	Rohde & Schwarz	CMU200	9/30/2011	9/30/2012
Directional Coupler	08736	Narda	4226-20	Time of Use	Time of Use

**6.4 Results:**

The following plots show that all spurious emissions are attenuated below the transmitting power (P) by a factor of at least  $43 + 10 \log(P)$  dB. Plots for emissions within 1MHz of the band edge as well as for emission outside of this range are shown.

GSM 850 Band - Low Channel - GPRS

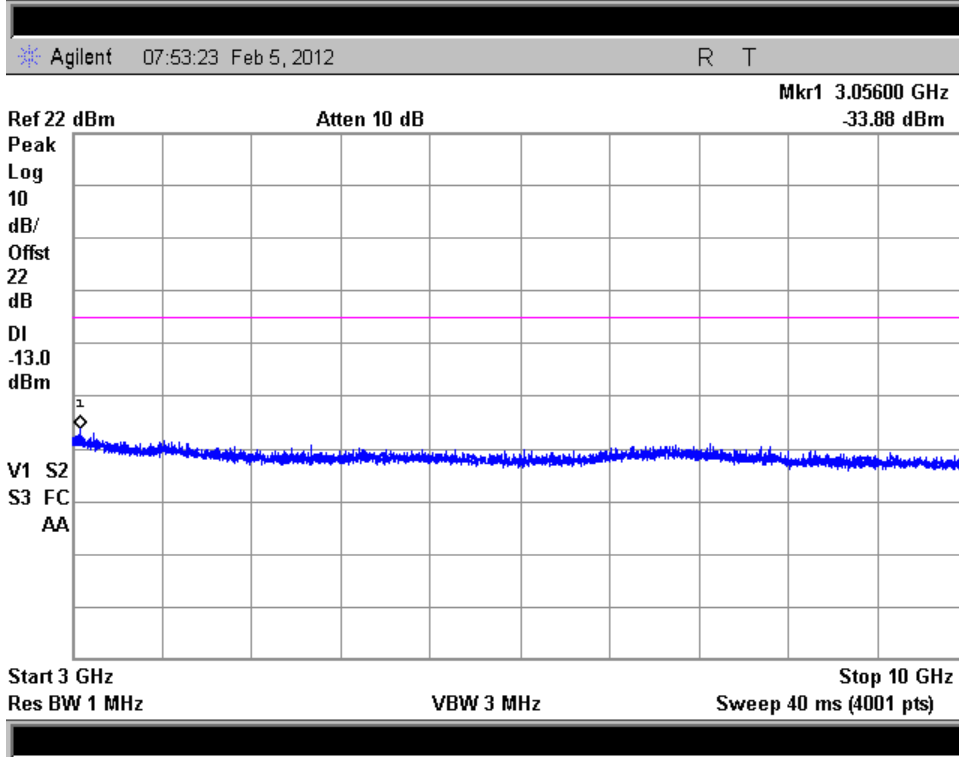
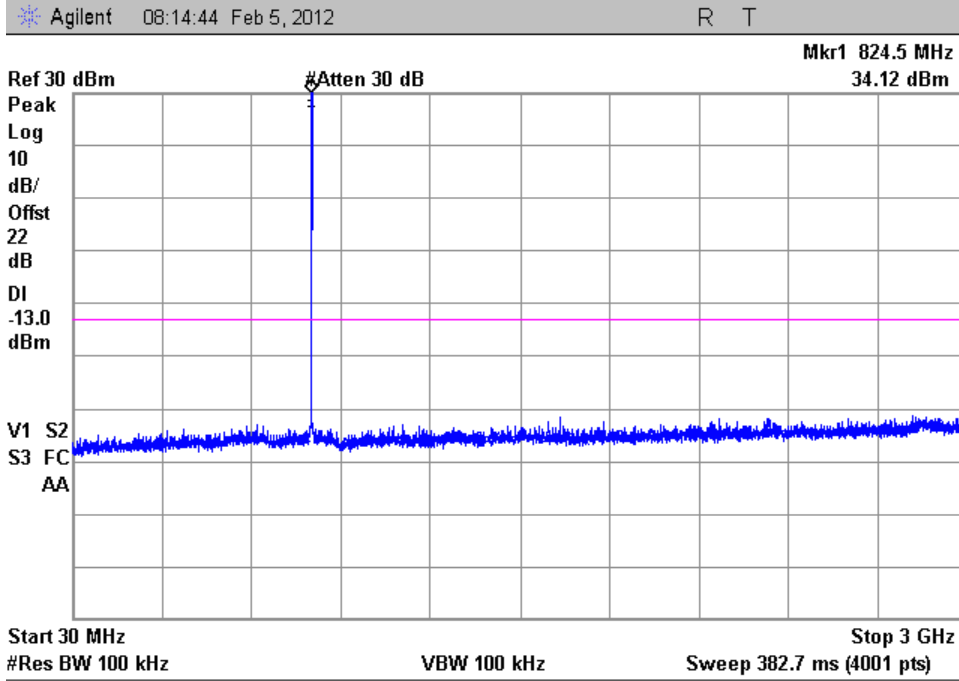

GSM 850 Band – Mid Channel - GPRS

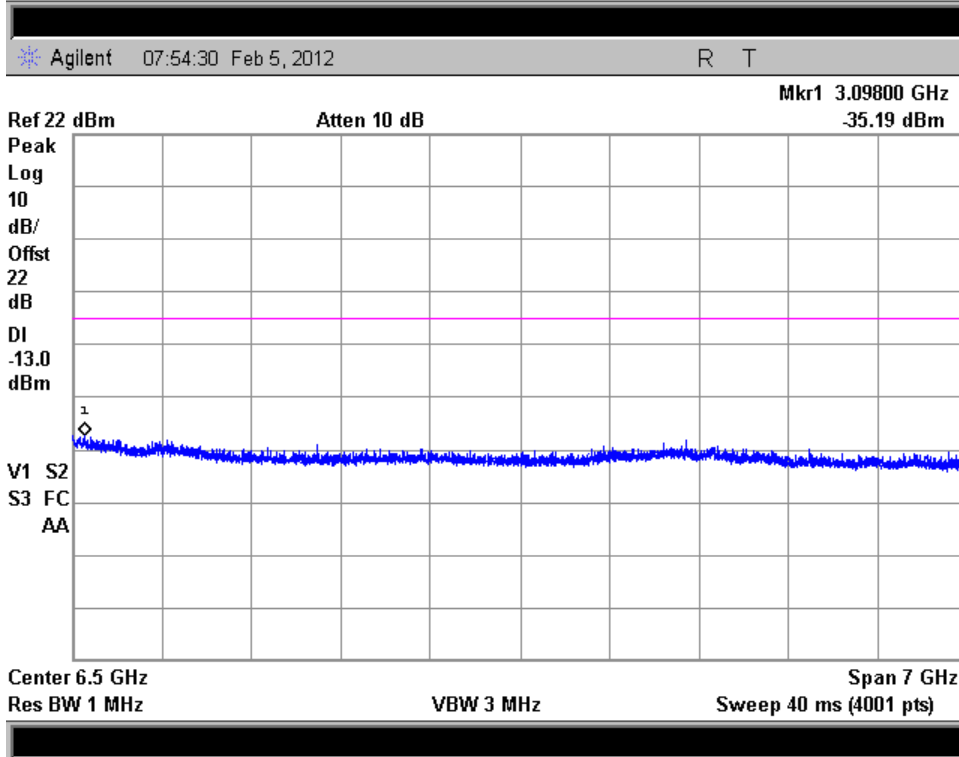
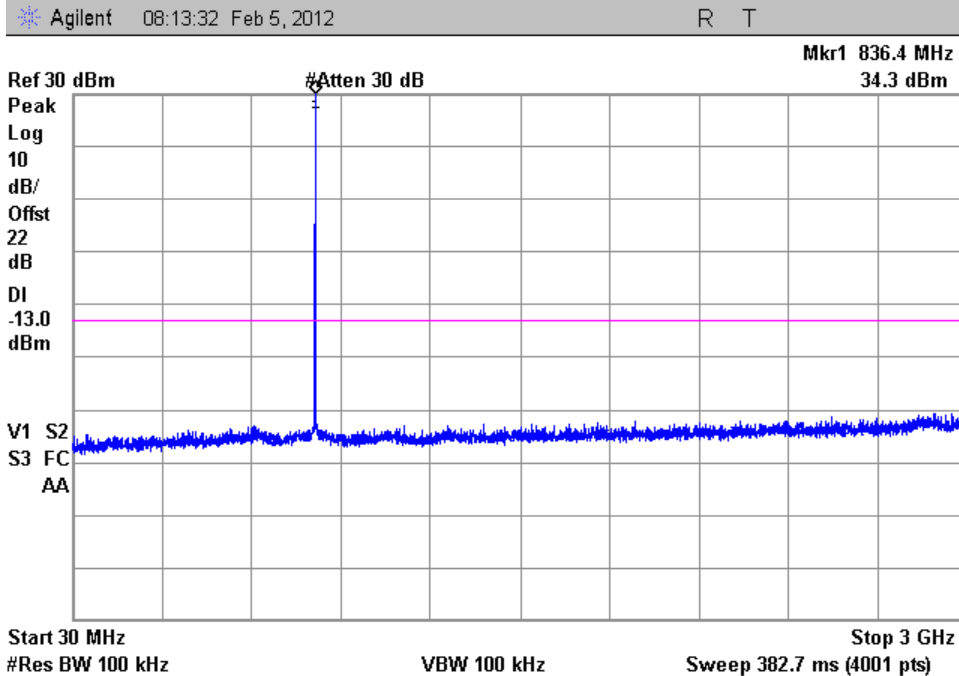



GSM 850 Band - High Channel - GPRS

Agilent 08:11:05 Feb 5, 2012 R T

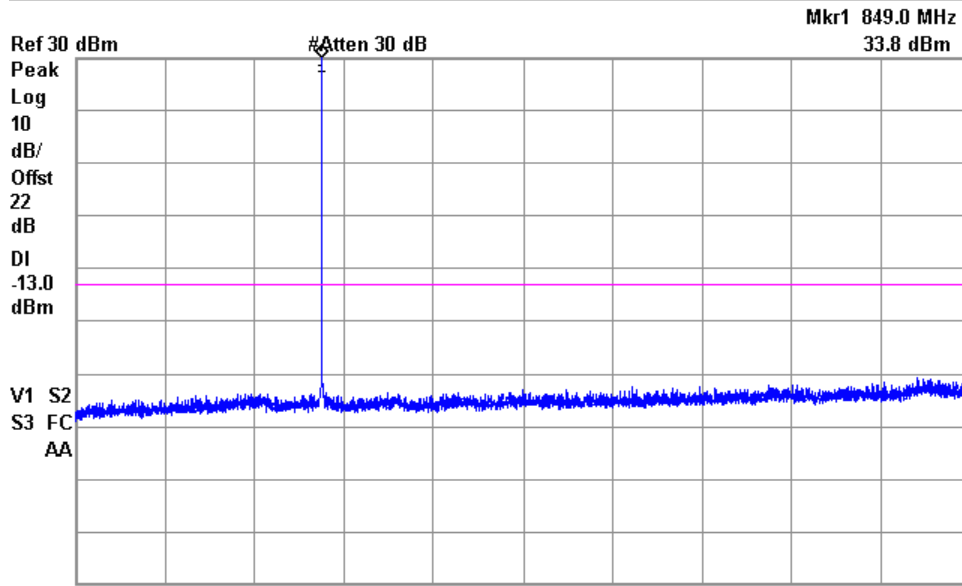

Start 30 MHz Stop 3 GHz  
#Res BW 100 kHz VBW 100 kHz Sweep 382.7 ms (4001 pts)



Agilent 08:01:59 Feb 5, 2012 R T

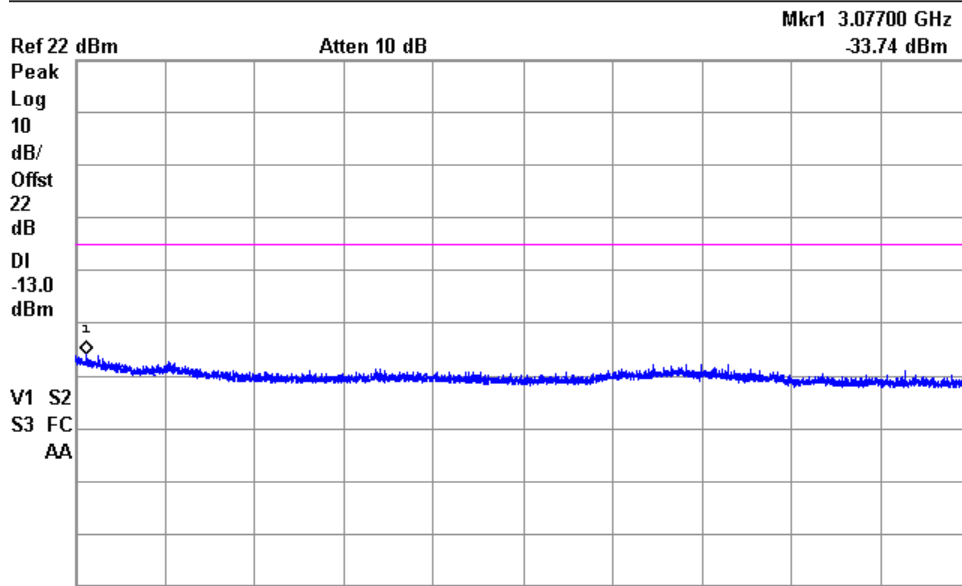

Center 6.5 GHz Span 7 GHz  
Res BW 1 MHz VBW 3 MHz Sweep 40 ms (4001 pts)



GSM 1900 Band - Low Channel - GPRS

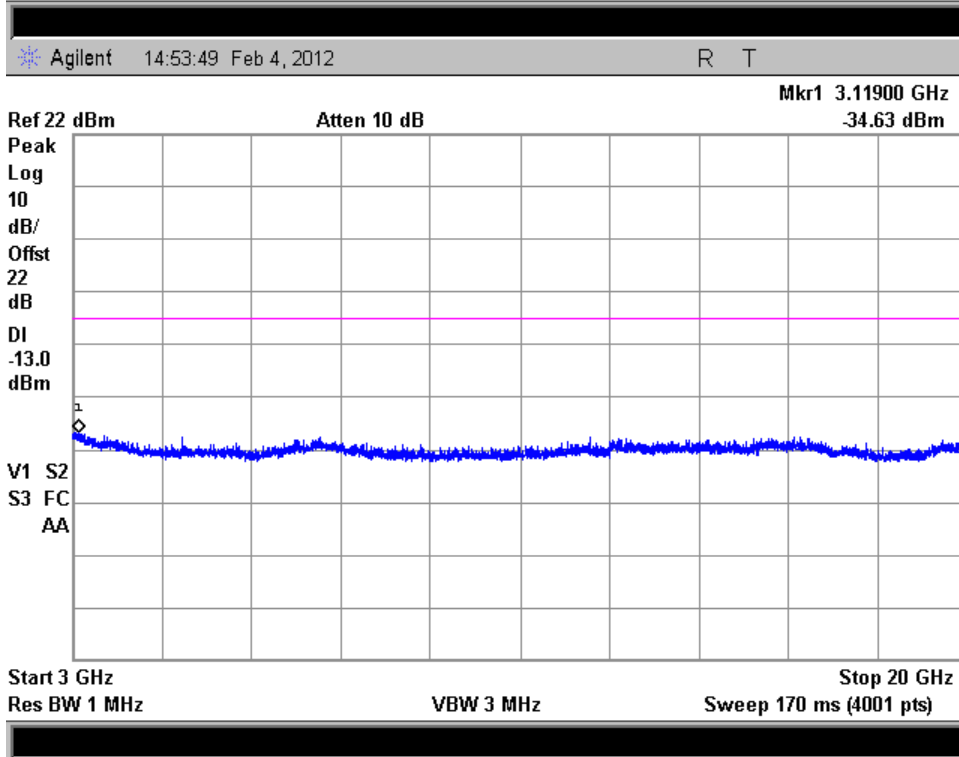
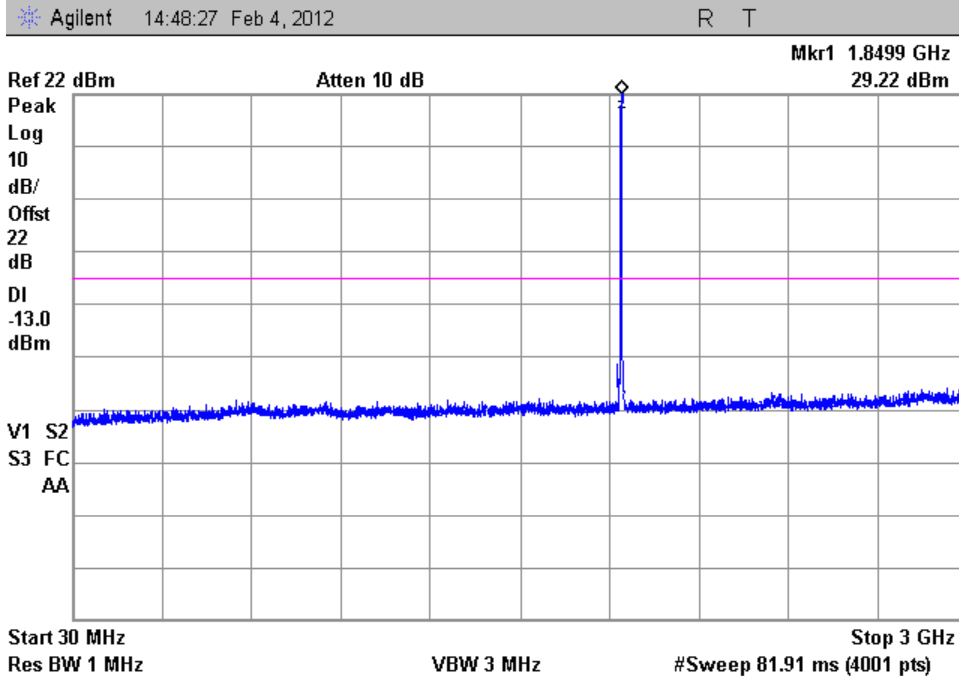

GSM 1900 Band – Mid Channel - GPRS

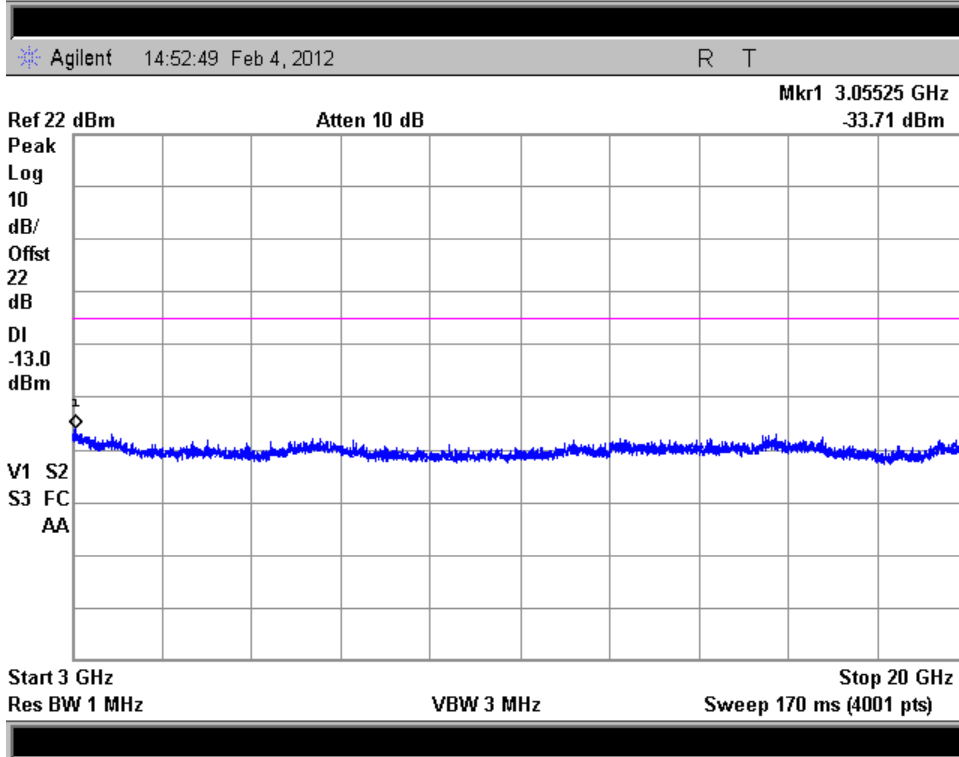
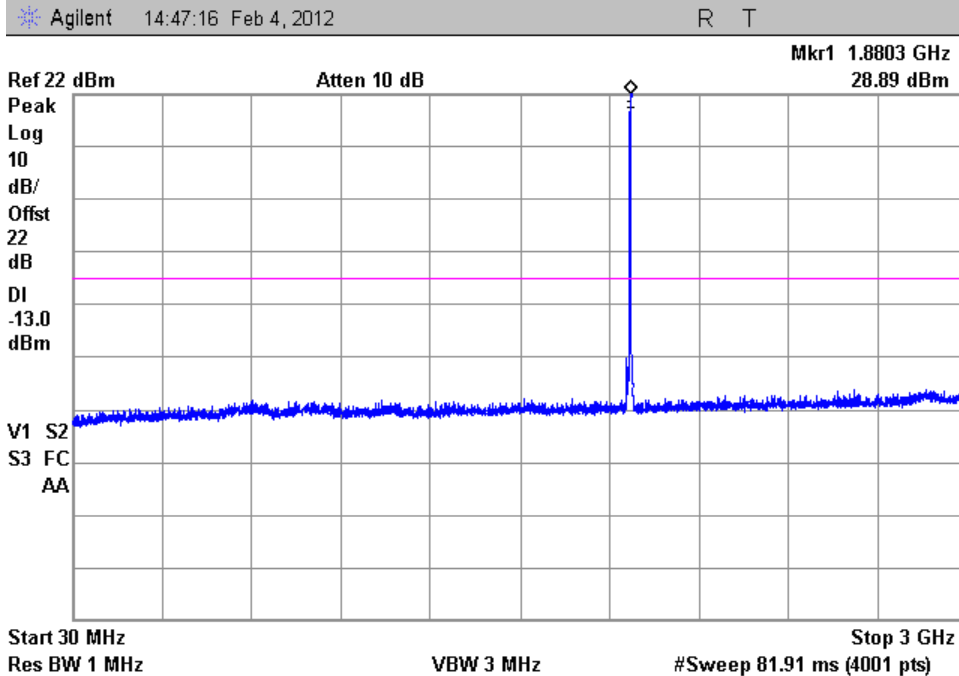

GSM 1900 Band - High Channel - GPRS

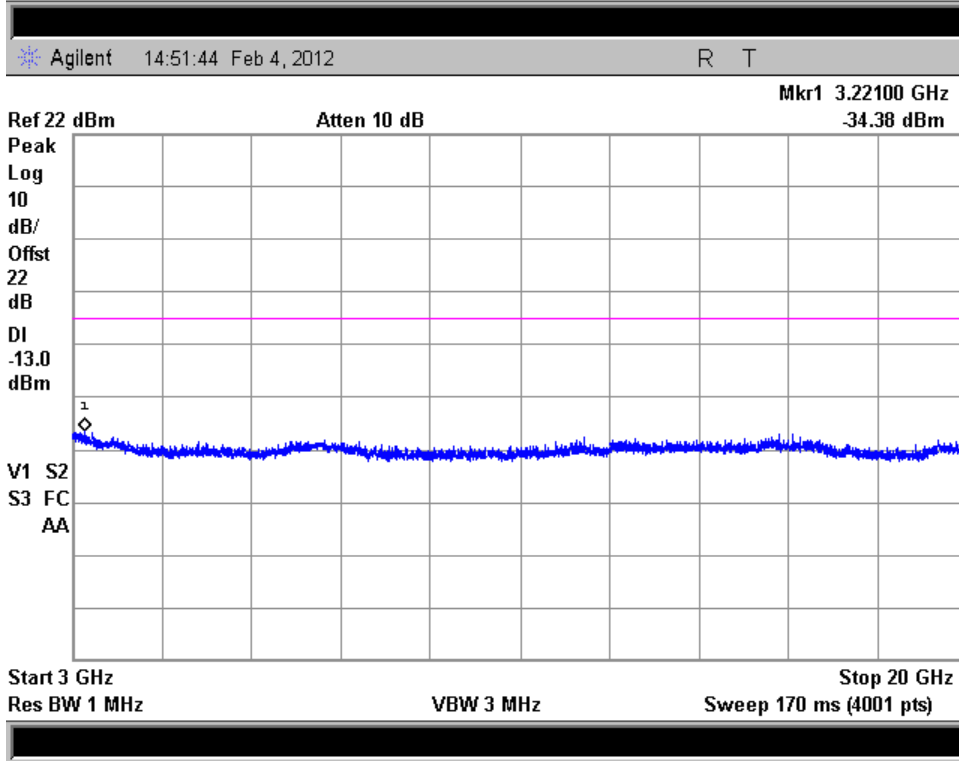
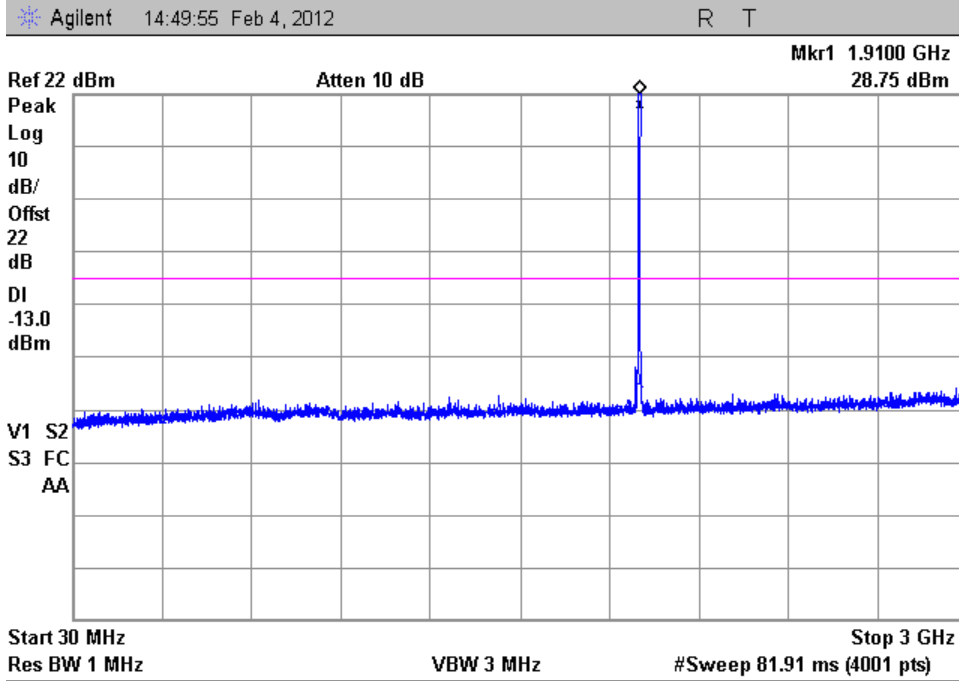

GSM 850 Band - Low Channel - EDGE

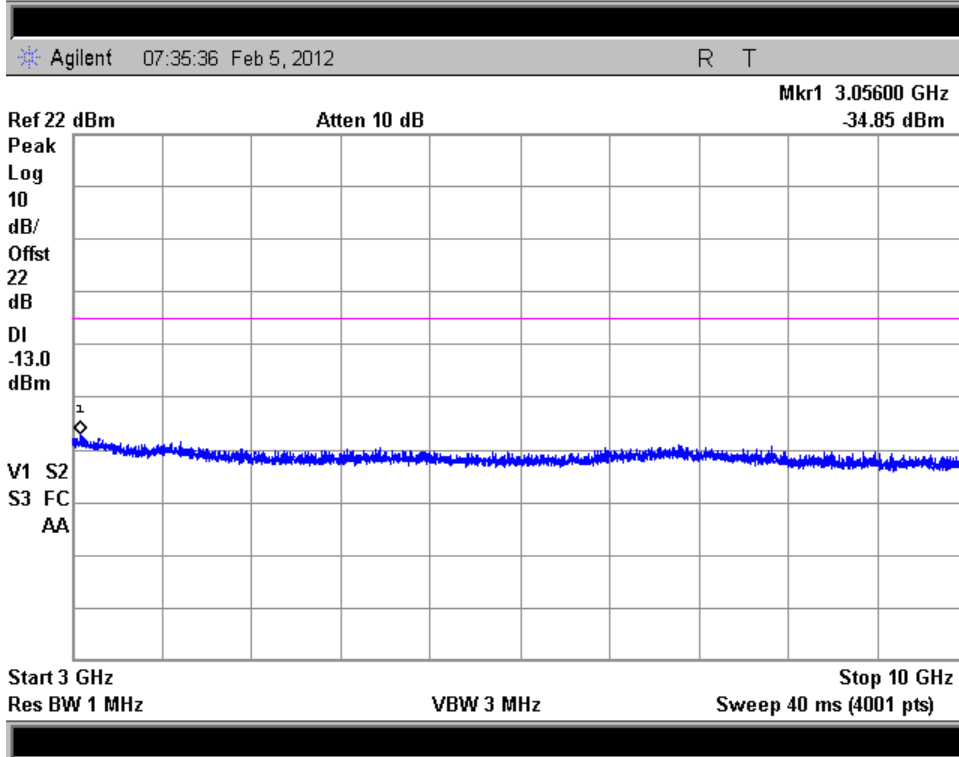
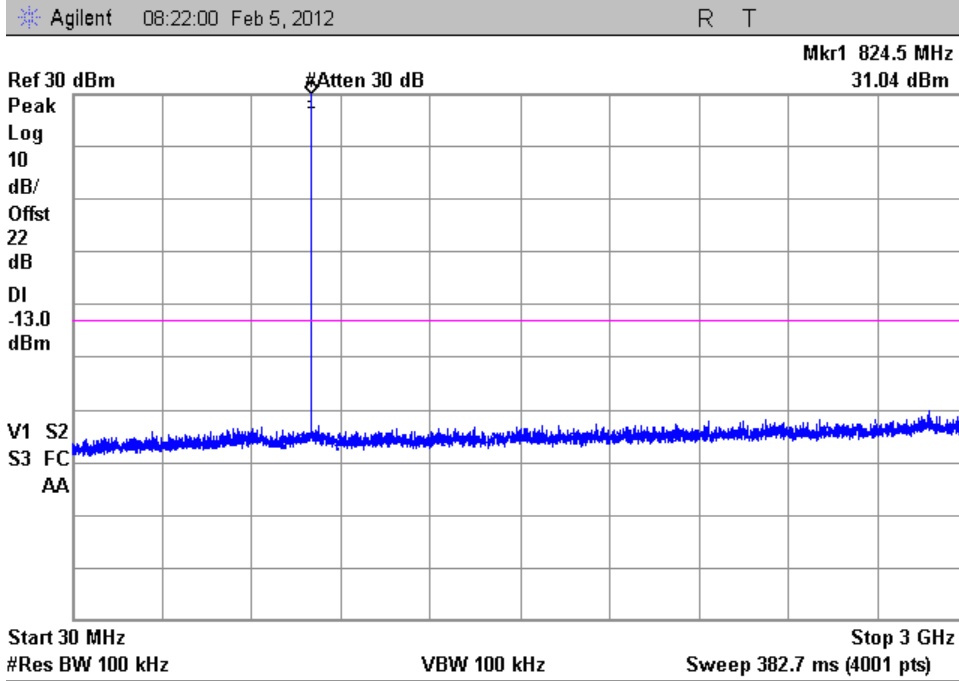

GSM 850 Band – Mid Channel - EDGE

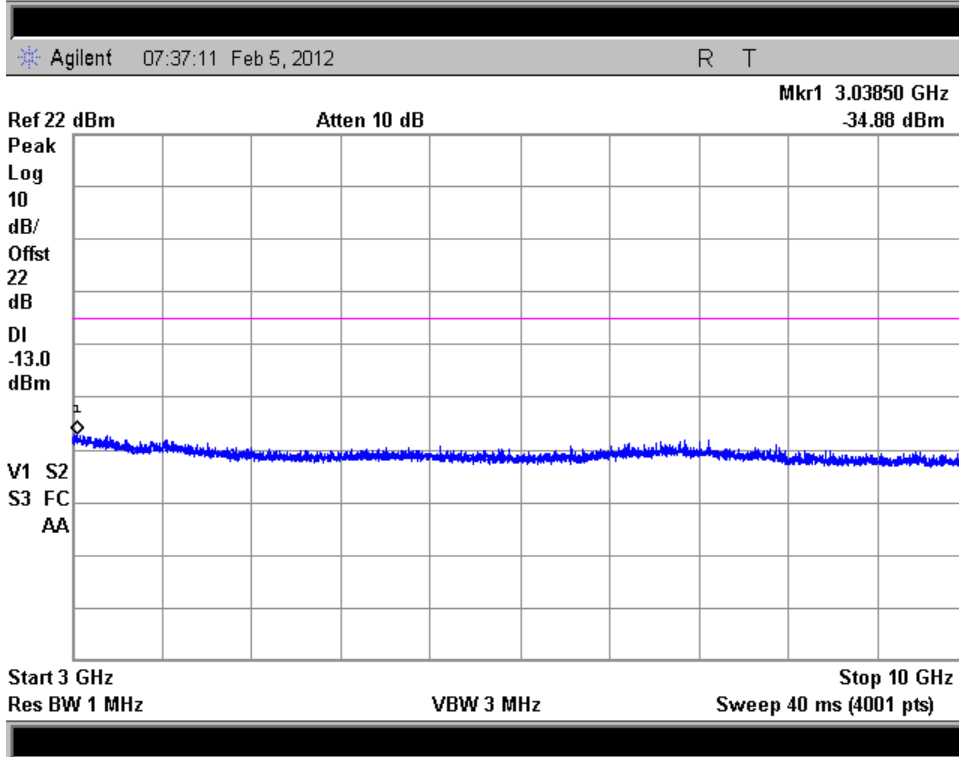
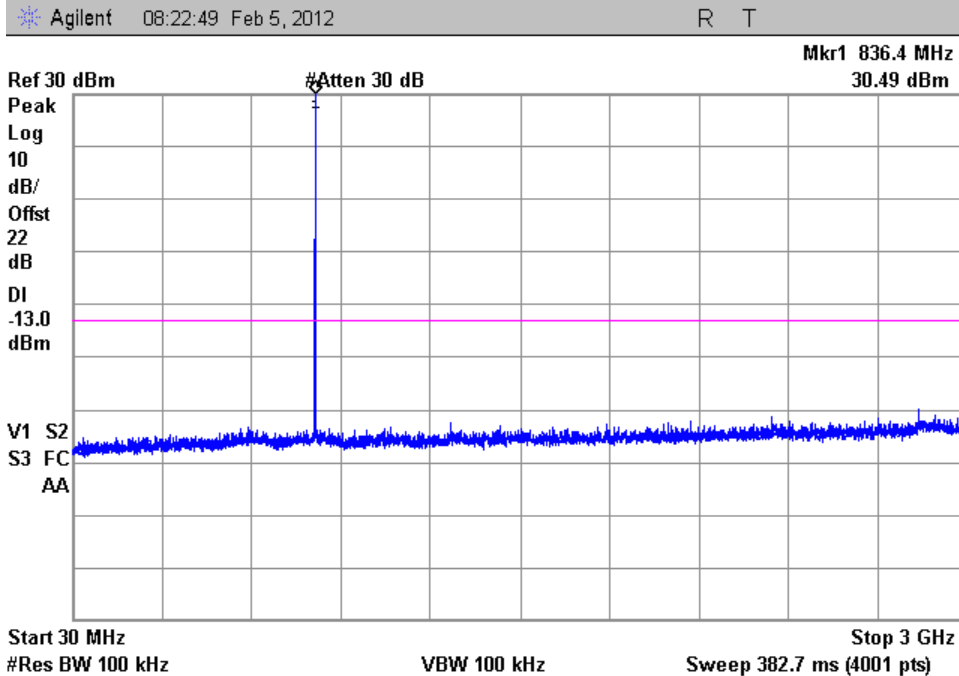

GSM 850 Band - High Channel - EDGE

Agilent 08:23:40 Feb 5, 2012 R T

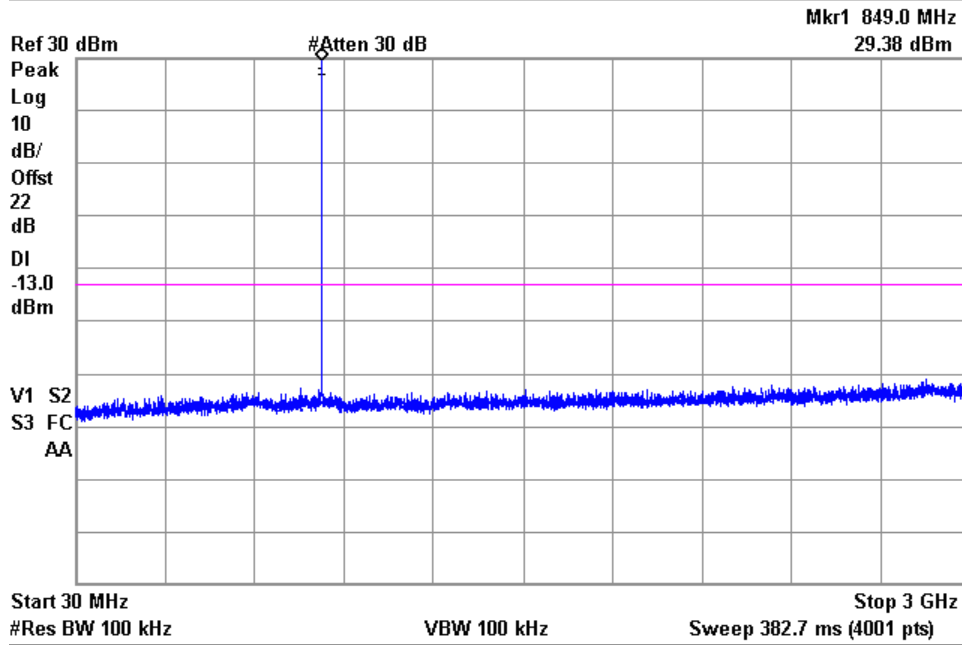

Agilent 07:38:54 Feb 5, 2012 R T

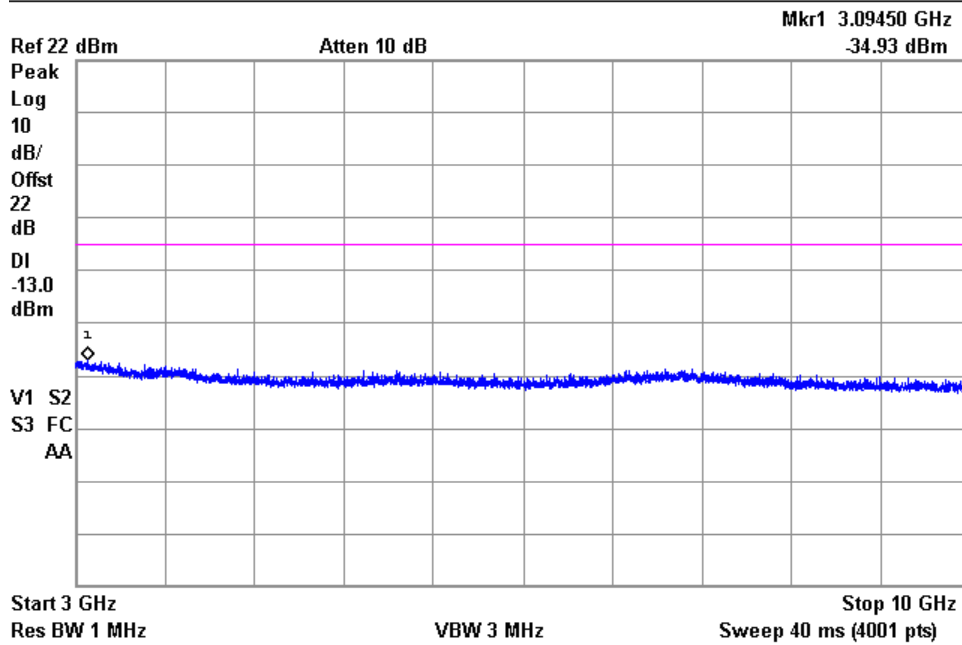

GSM 1900 Band - Low Channel - EDGE

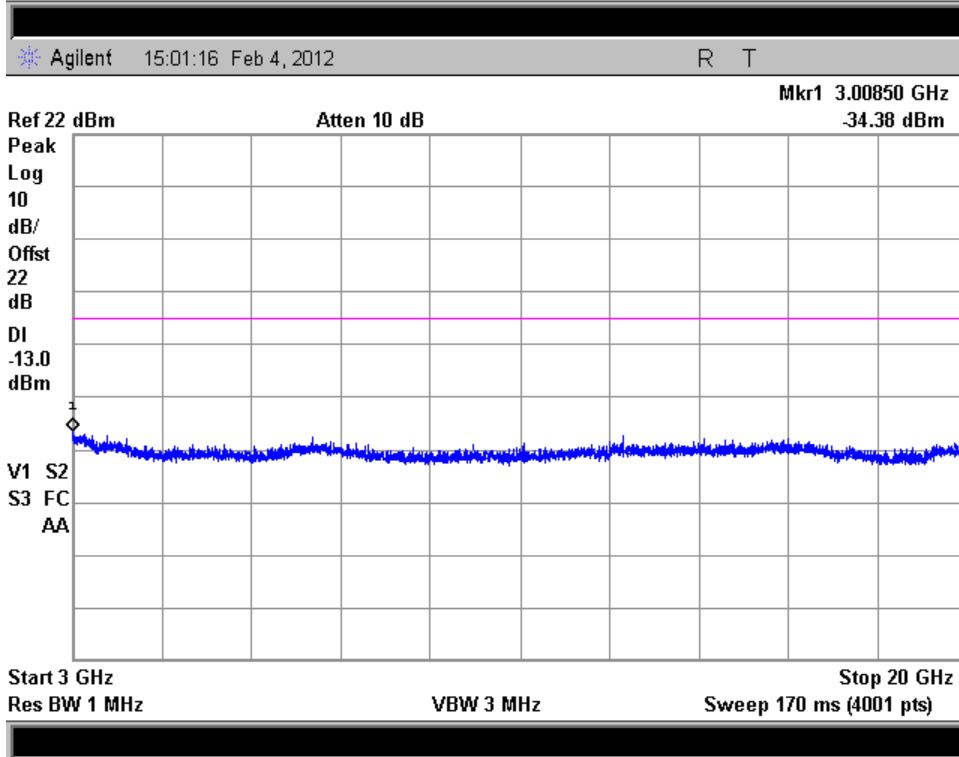
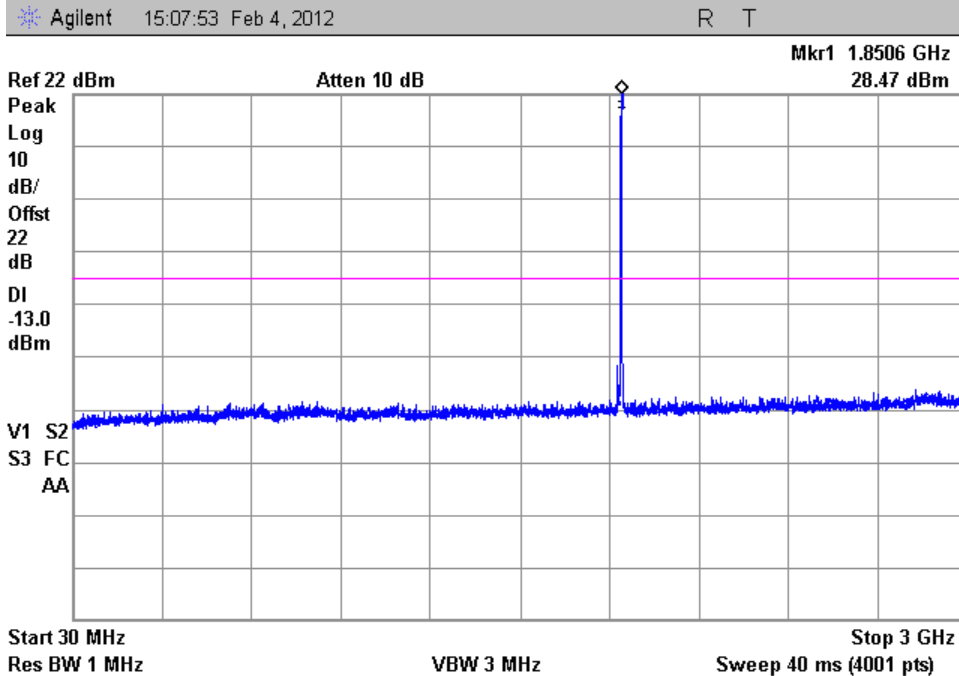



GSM 1900 Band – Mid Channel - EDGE

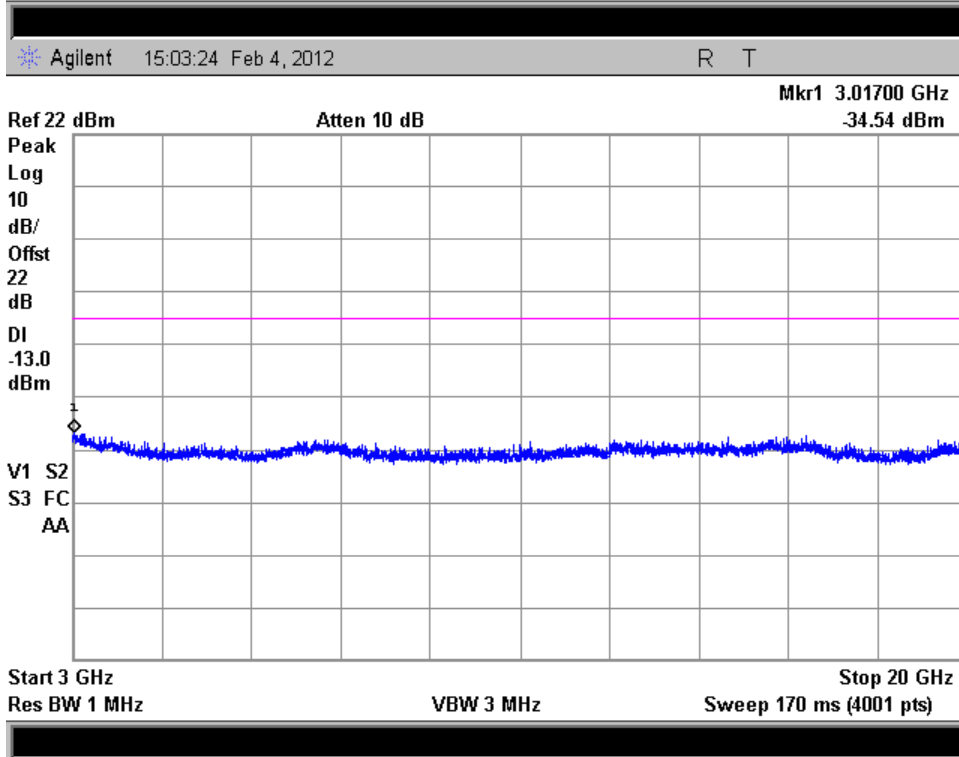
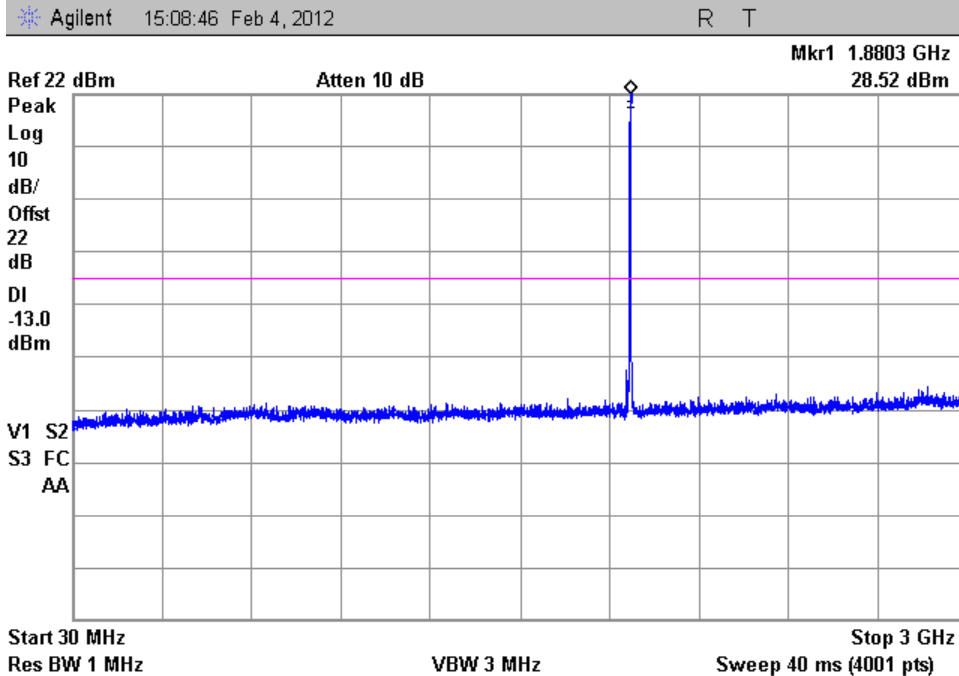

GSM 1900 Band - High Channel - EDGE

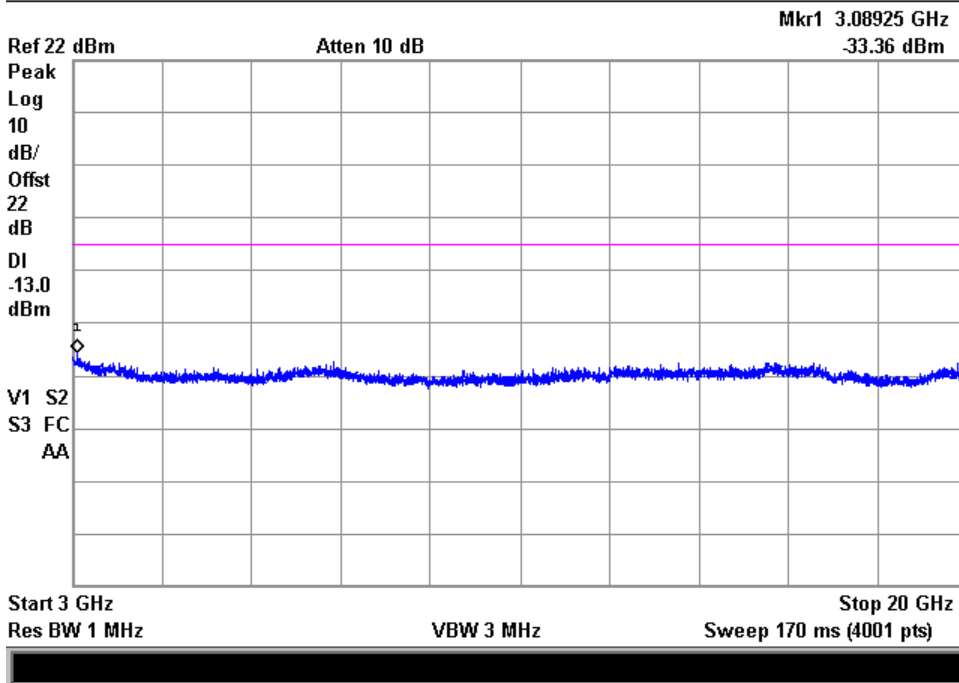
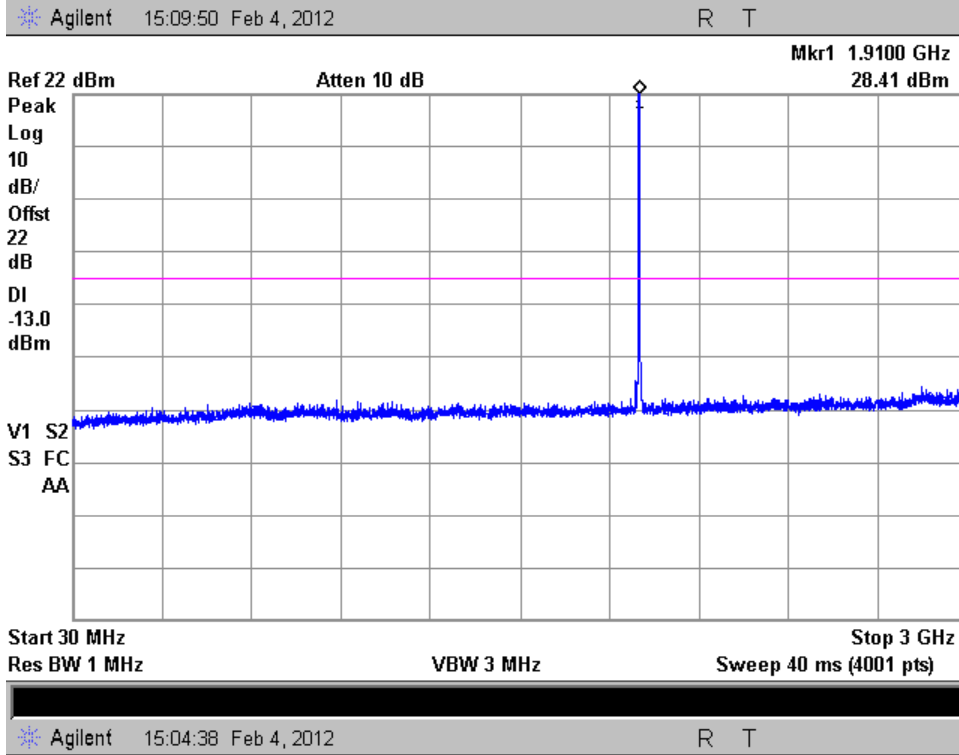

**Emissions within 4MHz of the block edge:**

**GSM 850 Band – Low Channel - GPRS**

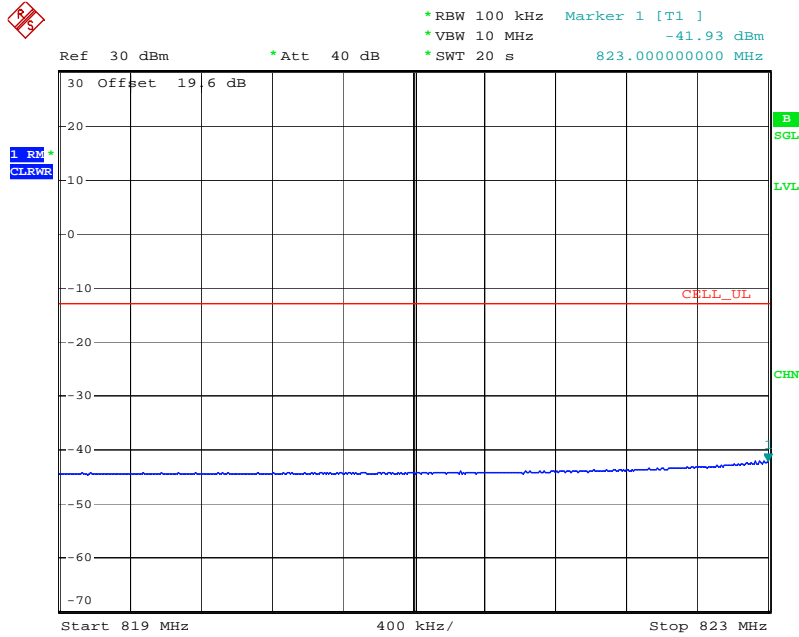

Date: 4.FEB.2012 15:04:58

**GSM 850 Band – High Channel - GPRS**

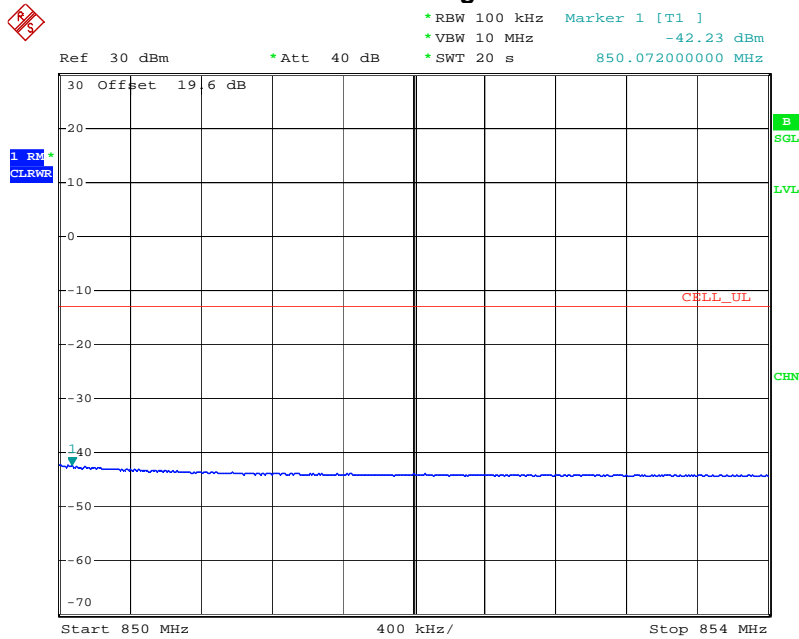

Date: 4.FEB.2012 15:07:37

GSM 1900 Band – Low Channel - GPRS

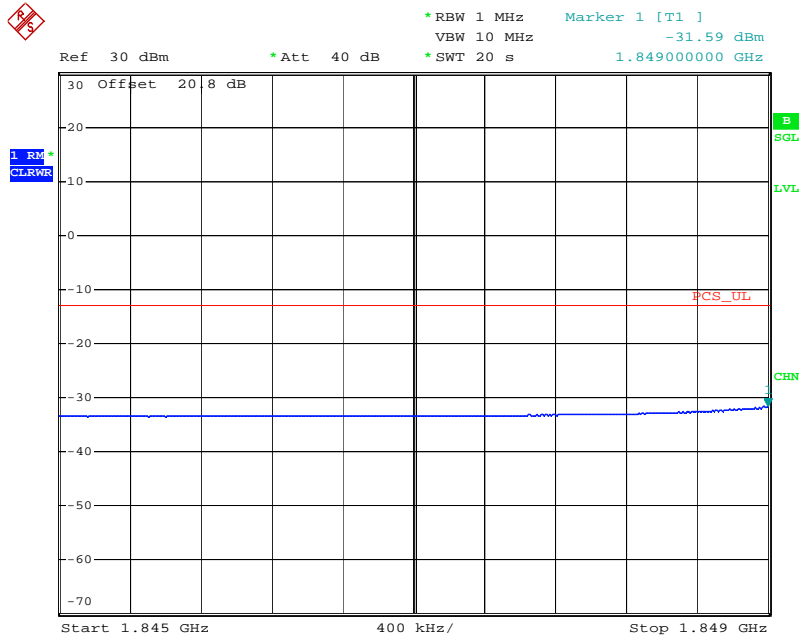

Date: 4.FEB.2012 16:41:37

GSM 1900 Band – High Channel – GPRS

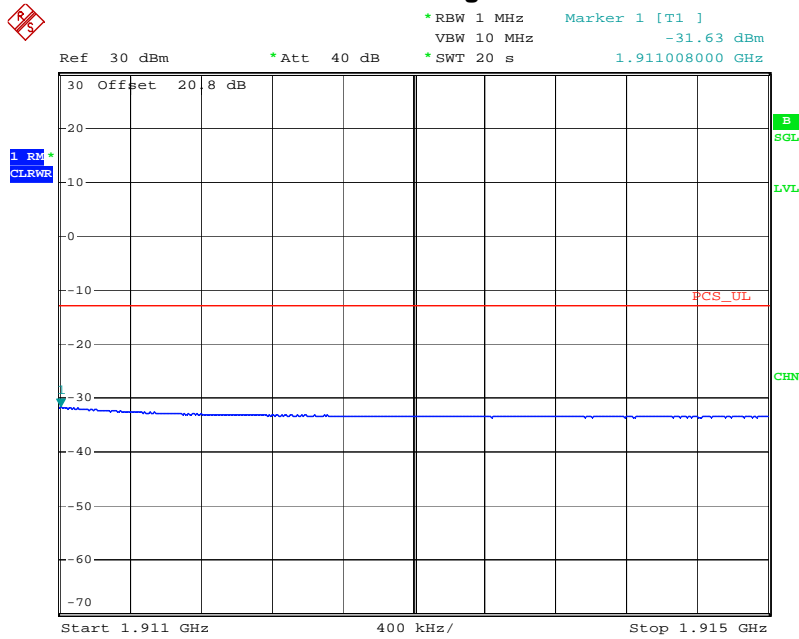

Date: 4.FEB.2012 16:44:31

GSM 850 Band – Low Channel - EDGE

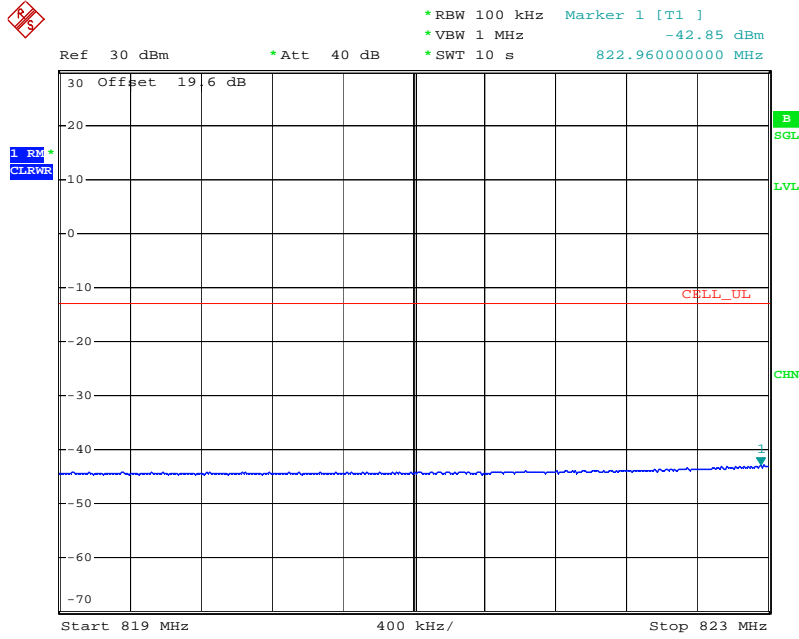

Date: 4.FEB.2012 15:21:53

GSM 850 Band – High Channel - EDGE

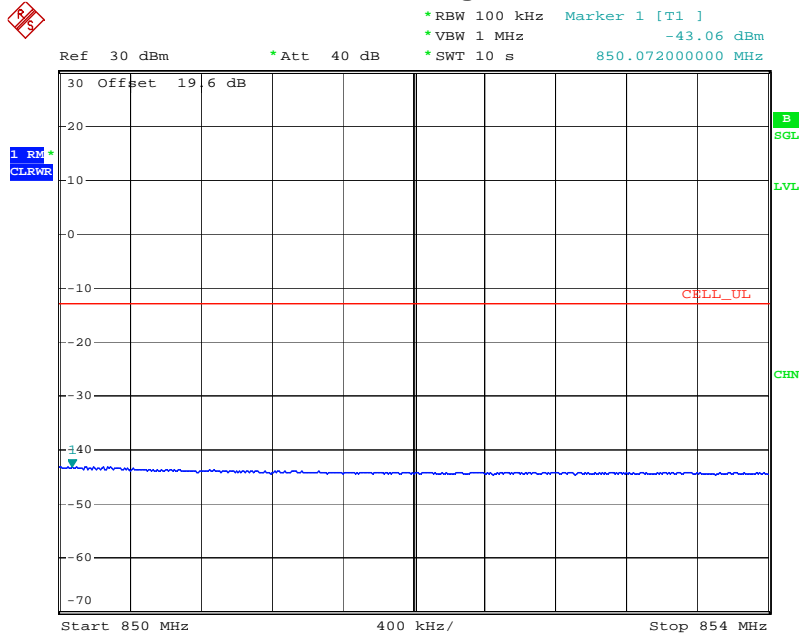

Date: 4.FEB.2012 15:23:08

GSM 1900 Band – Low Channel - EDGE

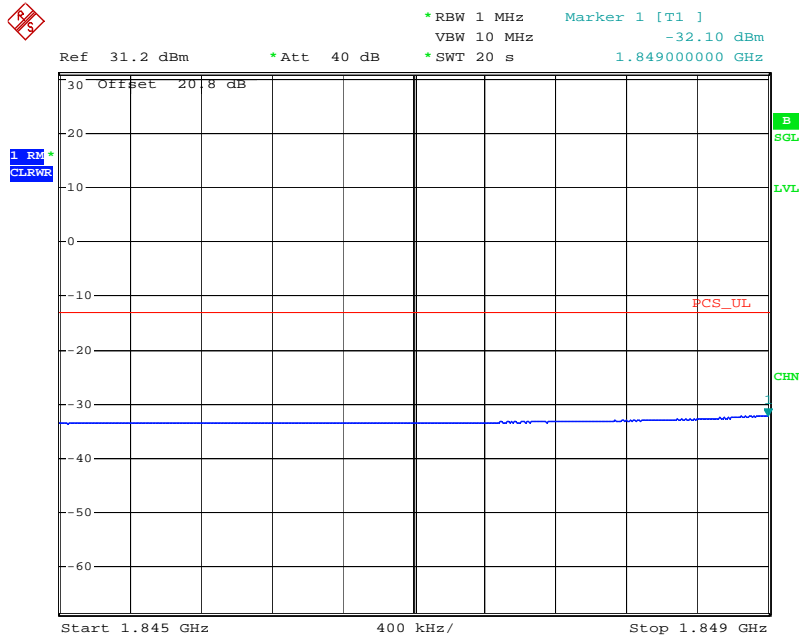

Date: 4.FEB.2012 15:45:53

GSM 1900 Band – High Channel – EDGE

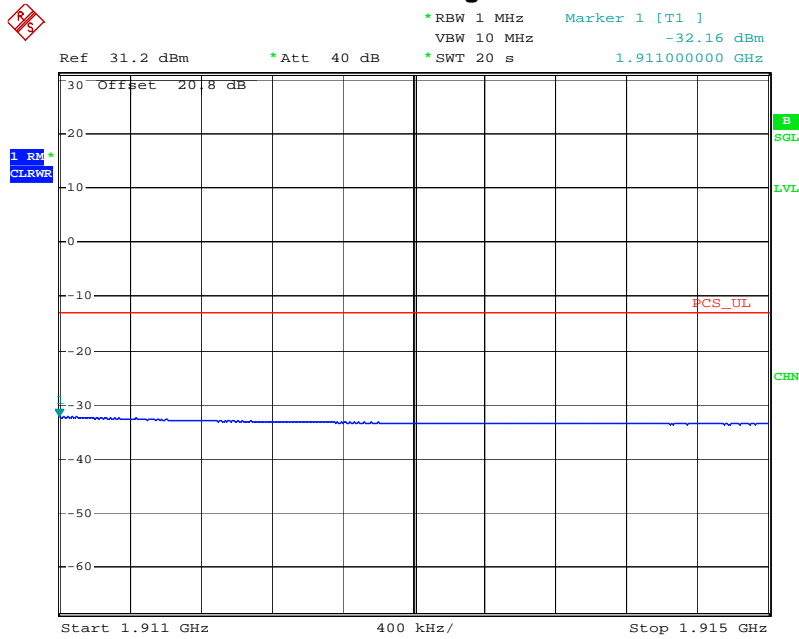

Date: 4.FEB.2012 16:15:33

**Emissions within 1MHz of the band edge:**

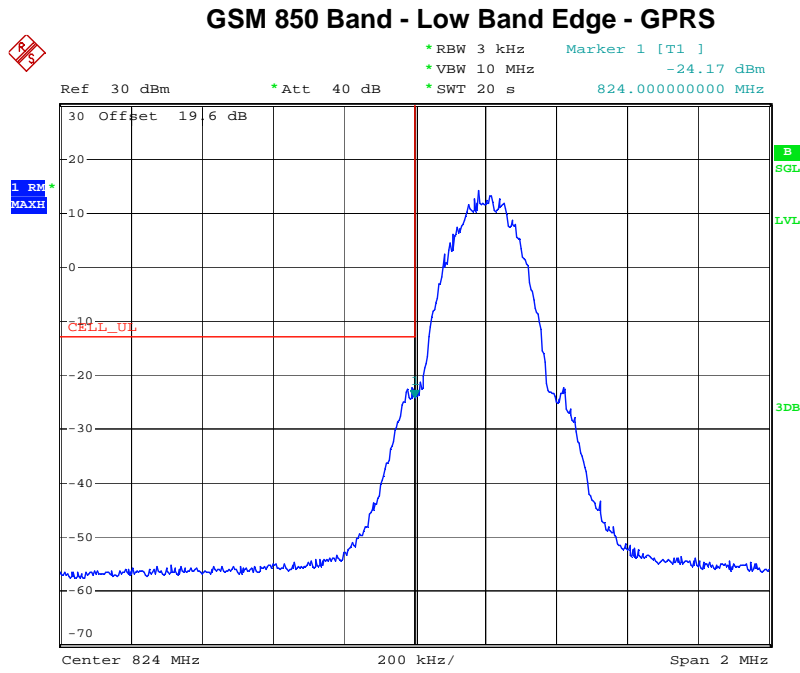

Date: 4.FEB.2012 15:02:47

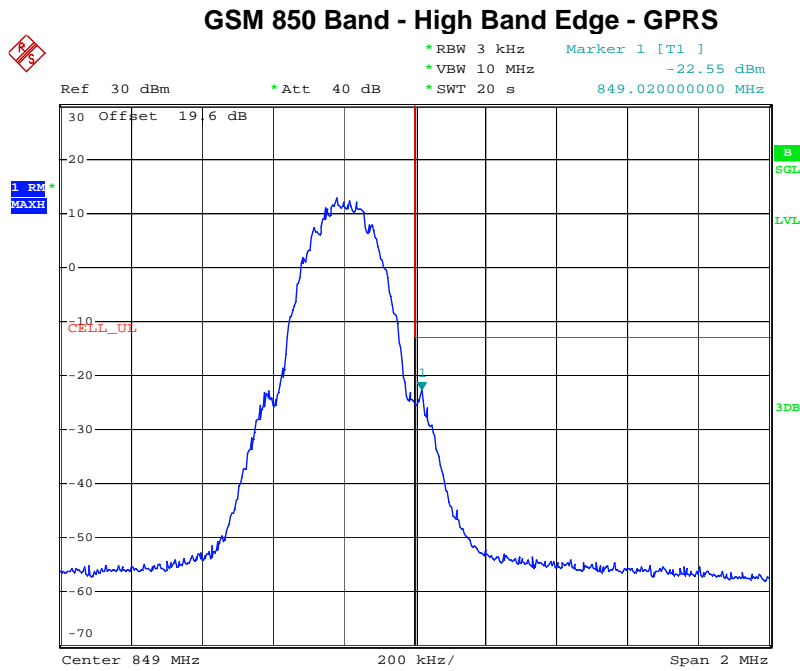

Date: 4.FEB.2012 15:01:50

### GSM 1900 Band - Low Band Edge - GPRS

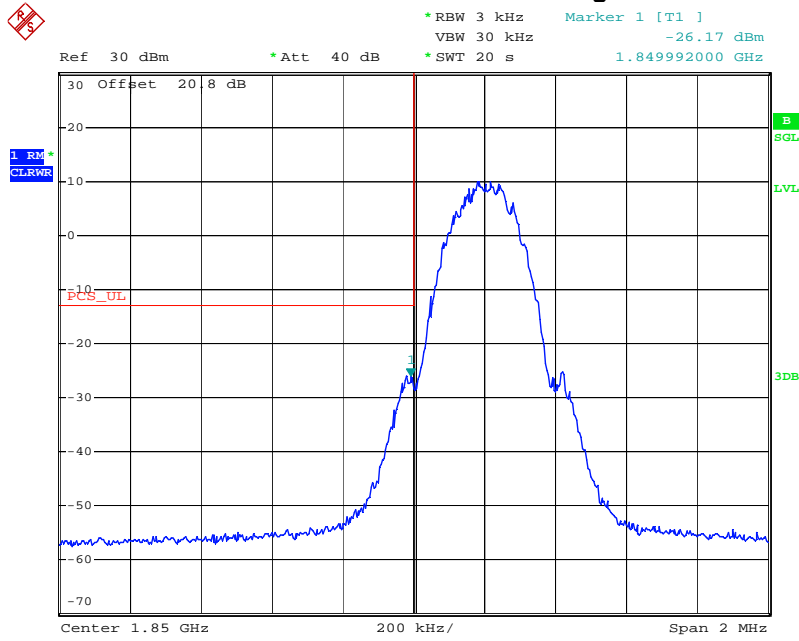

Date: 4.FEB.2012 16:47:17

### GSM 1900 Band - High Band Edge - GPRS

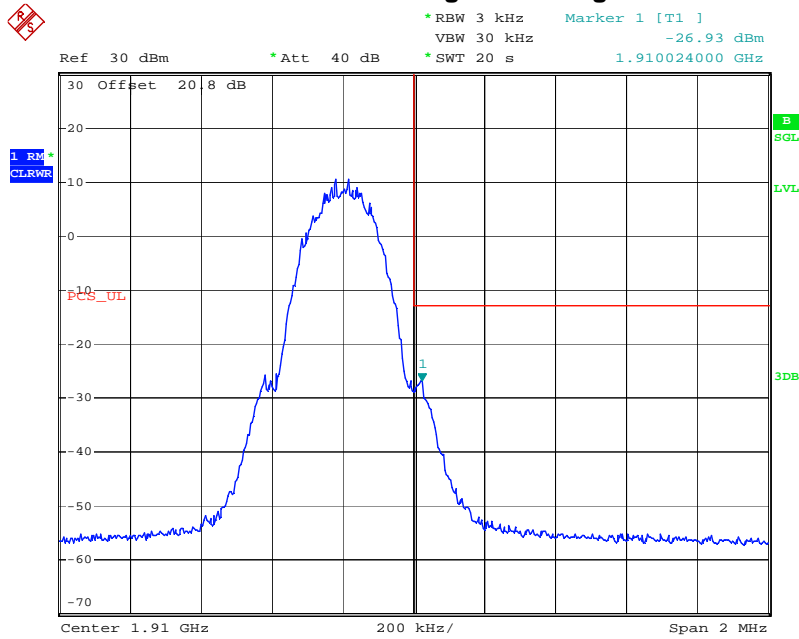

Date: 4.FEB.2012 16:46:15



GSM 850 Band - Low Band Edge - EDGE

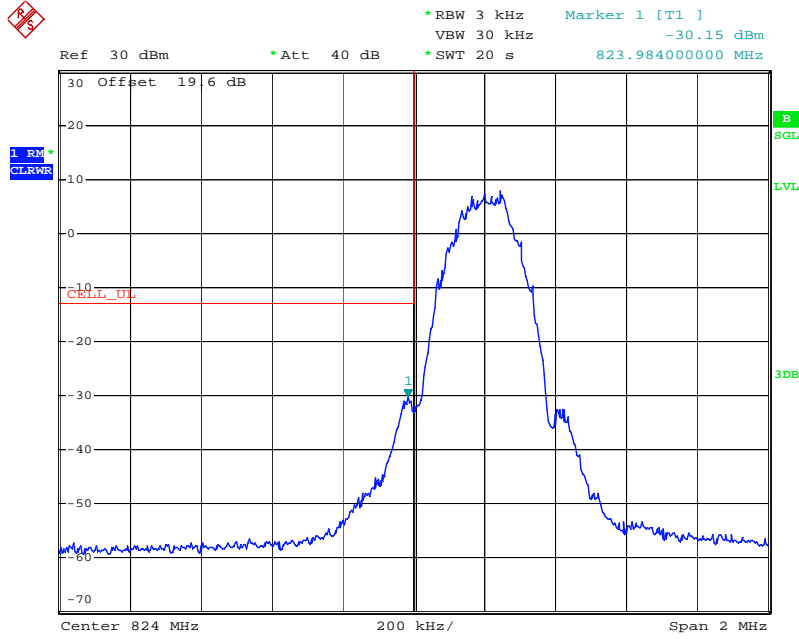

Date: 4.FEB.2012 15:32:19

GSM 850 Band - High Band Edge - EDGE

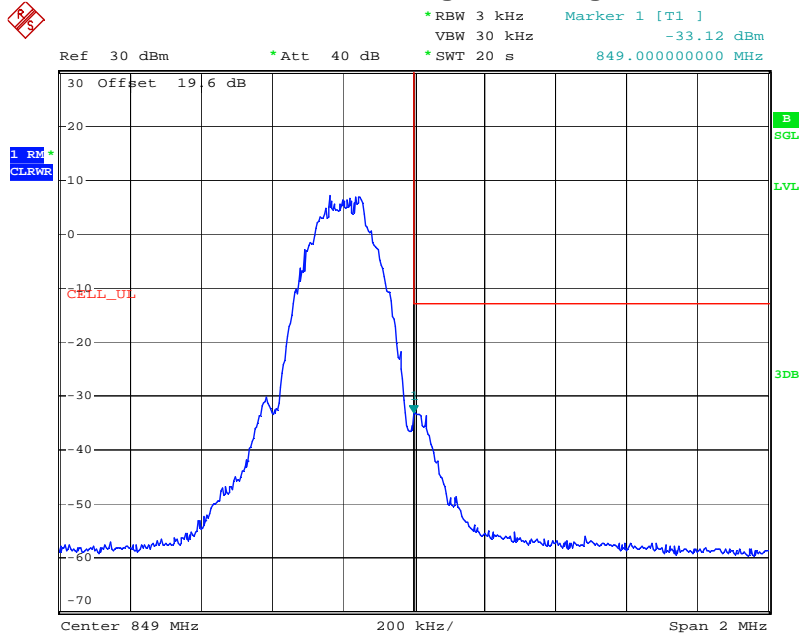

Date: 4.FEB.2012 15:30:02

GSM 1900 Band - Low Band Edge - EDGE

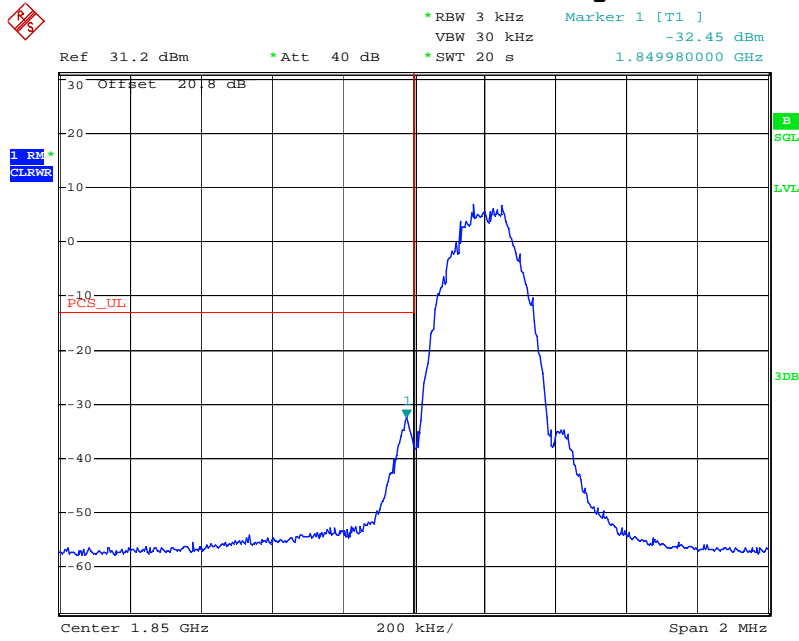

Date: 4.FEB.2012 15:38:53

GSM 1900 Band - High Band Edge - EDGE

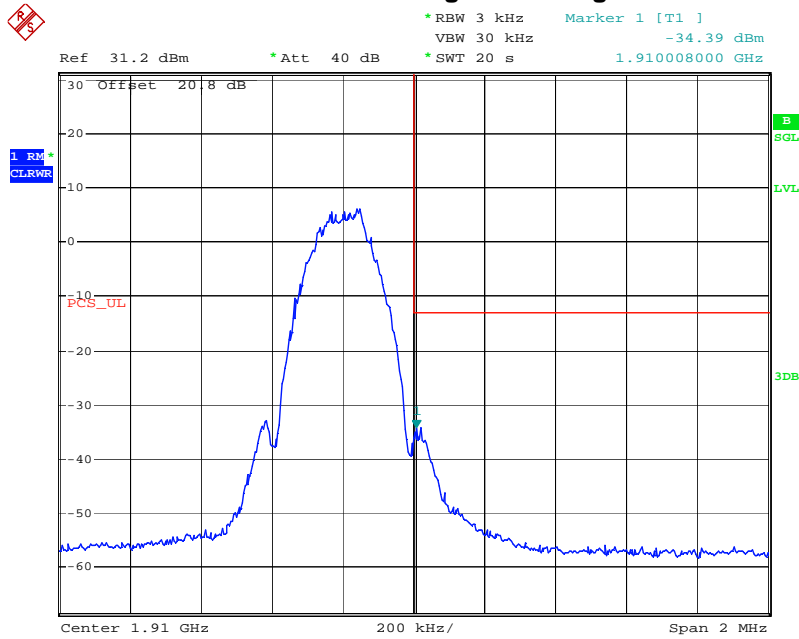

Date: 4.FEB.2012 15:42:27

## 7 Radiated Output Power

### 7.1 Test Limits

#### § 22.913

(a) (2) The ERP of mobile transmitters and auxiliary test transmitters must not exceed 7 Watts.

#### § 24.232

(c) Mobile and portable stations are limited to 2 watts EIRP and the equipment must employ a means for limiting power to the minimum necessary for successful communications.

### 7.2 Test Procedure

The radiated output power was determined by adding the peak antenna gain to the measured conducted output power to determine the peak radiated power.

$$ERP = ConductedOutputPower(dBm) + AntennaGain(dBi) - 2.15$$

$$EIRP = ConductedOutputPower(dBm) + AntennaGain(dBi)$$

### 7.3 Results:

The Wireless Control Tablet meets the radiated power requirements of FCC §22.913 and §24.232.

Band	Channel	Frequency (MHz)	Conducted Power (dBm)	Peak Antenna Gain (dBi)	EIRP (dBm)	ERP(dBm)
GSM 850 (GPRS)	128	824.2	32.17	-0.12	32.05	29.9
	190	836.6	32.04	0.24	32.28	<b>30.13</b>
	251	848.8	31.88	0.35	32.23	30.08
GSM 1900 (GPRS)	512	1850.2	29.04	2.09	31.13	28.98
	661	1880	28.82	2.51	<b>31.33</b>	29.18
	810	1909.8	28.6	2.7	31.3	29.15
GSM 850 (EDGE)	128	824.2	26.22	-0.12	26.1	23.95
	190	836.6	26.15	0.24	26.39	<b>24.24</b>
	251	848.8	25.9	0.35	26.25	24.1
GSM 1900 (EDGE)	512	1850.2	25.58	2.09	27.67	25.52
	661	1880	25.3	2.51	27.81	25.66
	810	1909.8	25.12	2.7	<b>27.82</b>	25.67

## 8 Radiated Spurious Emissions (Transmitter)

### 8.1 Test Limits

#### § 2.1053

- (a) Measurements shall be made to detect spurious emissions that may be radiated directly from the cabinet, control circuits, power leads, or intermediate circuit elements under normal conditions of installation and operation. Curves or equivalent data shall be supplied showing the magnitude of each harmonic and other spurious emission. For this test, single sideband, independent sideband, and controlled carrier transmitters shall be modulated under the conditions specified in paragraph (c) of §2.1049, as appropriate. For equipment operating on frequencies below 890 MHz, an open field test is normally required, with the measuring instrument antenna located in the far-field at all test frequencies. In the event it is either impractical or impossible to make open field measurements (e.g. a broadcast transmitter installed in a building) measurements will be accepted of the equipment as installed. Such measurements must be accompanied by a description of the site where the measurements were made showing the location of any possible source of reflections which might distort the field strength measurements. Information submitted shall include the relative radiated power of each spurious emission with reference to the rated power output of the transmitter, assuming all emissions are radiated from halfwave dipole antennas.

#### § 22.917

- (a) Out of band emissions. The power of any emission outside of the authorized operating frequency ranges must be attenuated below the transmitting power (P) by a factor of at least  $43 + 10 \log(P)$  dB.
- (b) Measurement procedure. Compliance with these rules is based on the use of measurement instrumentation employing a resolution bandwidth of 100 kHz or greater. In the 1 MHz bands immediately outside and adjacent to the frequency block a resolution bandwidth of at least one percent of the emission bandwidth of the fundamental emission of the transmitter may be employed. A narrower resolution bandwidth is permitted in all cases to improve measurement accuracy provided the measured power is integrated over the full required measurement bandwidth ( i.e. 100 kHz or 1 percent of emission bandwidth, as specified). The emission bandwidth is defined as the width of the signal between two points, one below the carrier center frequency and one above the carrier center frequency, outside of which all emissions are attenuated at least 26 dB below the transmitter power.

#### § 24.238

- (a) Out of band emissions. The power of any emission outside of the authorized operating frequency ranges must be attenuated below the transmitting power (P) by a factor of at least  $43 + 10 \log(P)$  dB.
- (b) Measurement procedure. Compliance with these rules is based on the use of measurement instrumentation employing a resolution bandwidth of 1 MHz or greater. However, in the 1 MHz bands immediately outside and adjacent to the frequency block a resolution bandwidth of at least one percent of the emission bandwidth of the fundamental emission of the transmitter may be employed. A narrower resolution bandwidth is permitted in all cases to improve measurement accuracy provided the measured power is integrated over the full required measurement bandwidth ( i.e. 1 MHz or 1 percent of emission bandwidth, as specified). The emission bandwidth is defined as the width of the signal between two points, one below the carrier center frequency and one above the carrier center frequency, outside of which all emissions are attenuated at least 26 dB below the transmitter power.

## 8.2 Test Procedure

The EUT was placed on a non-conductive turntable. The measurement antenna was placed at a distance of 3 meters from the EUT. The EUT was forced to transmit at its maximum output power setting. During the tests, the antenna height and EUT azimuth were varied in order to identify the maximum level of emissions from the EUT.

The frequency range up to tenth harmonic was investigated in order to identify the spurious emission. Once the spurious emissions were identified, the power of the emission was determined using the substitution method described in TIA-603-C. The spurious emissions attenuation was calculated as the difference between radiated power at the fundamental frequency and at the spurious emissions frequency.

## 8.3 Test Equipment Used:

Description	Serial Number	Manufacturer	Model	Cal. Date	Cal. Due
EMI Test Receiver	10887490.26	Rohde & Schwarz	ESI26	6/29/2011	6/29/2012
Preamplifier	987410	Miteq	AFS44-00102000-30-10P-44	9/12/2011	9/12/2012
Preamplifier	SF456200904	Mini-Circuits	ZX60-3018G-S+	9/12/2011	9/12/2012
Biconnilog Antenna	00051864	ETS	3142C	12/20/2011	12/20/2012
Horn Antenna	6556	ETS	3115	8/24/2011	8/24/2012
Horn Antenna	1096	Antenna Research	DRG-118/A	7/20/2011	7/20/2012
System Controller	121701-1	Sunol Sciences	SC99V	Calibration Not Required	Calibration Not Required
High Pass Filter	3986-01 DC0408	Microwave Circuits, Inc.	H3G020G2	Calibrate at Time Of Use	Calibrate at Time Of Use
Base Station Simulator	3101	Rohde & Schwarz	CMU200	6/1/2011	6/1/2012

**8.4 Results:**

All radiated spurious emissions were attenuated below the transmitting power (P) by a factor of at least 43 + 10 log(P) dB which is equivalent to -13dBm.

**Worst Case Spurious Measurements – GSM 850 Band – GPRS Mode**

Radiated Spurious Emissions Measurement								
Test Engineer: J. Centers Test Date: 2/7/2012 Temp. / Humidity / Pressure: 24.2C/24.6%/988.8mbar Bandwidth Settings: RBW = VBW = 1MHz Notes: Spurious emissions not reported here were below the measurement noise floor.								
Band/Channel	Spurious Frequency (MHz)	Polarity	Device Reading (dBm)	Signal Generator Level (dBm)	Cable Loss (dB)	Tx Antenna Gain (dBd)	Limit (dBm)	Radiated Spurious Emission Level (dBm)
GSM 850 Band; GPRS Mode; Low Channel (128)	1648.4	H	-65.01	-28.92	3.26	6.70	-13	-25.48
	1648.4	V	-58.71	-23.64	3.26	6.70	-13	-20.20
	2472.6	H	-81.52	-41.56	4.17	7.16	-13	-38.57
	2472.6	V	-77.12	-35.21	4.17	7.16	-13	-32.22
	3296.8	H	-63.38	-59.67	4.58	7.14	-13	-57.11
	3296.8	V	-65.07	-58.77	4.58	7.14	-13	-56.21
	4121	H	-68.27	-61.74	5.33	8.15	-13	-58.92
	4121	V	-68.35	-60.88	5.33	8.15	-13	-58.06
	4945.2	H	-63.61	-55.51	5.82	8.80	-13	-52.53
	4945.2	V	-62.96	-55.4	5.82	8.80	-13	-52.42
	5769.4	H	-69.2	-57.9	6.75	9.27	-13	-55.38
	5769.4	V	-70.2	-60.3	6.75	9.27	-13	-57.78
	6593.6	H	-71.19	-54.63	7.45	9.96	-13	-52.12
	6593.6	V	-68.82	-52.38	7.45	9.96	-13	-49.87
	7417.8	H	-71.84	-51.66	7.78	8.72	-13	-50.72
	7417.8	V	-72.26	-51.56	7.78	8.72	-13	-50.62
GSM 850 Band; GPRS Mode; Mid Channel (190)	8242	H	-72.96	-49.71	8.23	9.16	-13	-48.78
	8242	V	-72.28	-52.28	8.23	9.16	-13	-51.35
	1673.2	H	-64.86	-28.4	3.30	6.70	-13	-25.00
	1673.2	V	-60.73	-24.56	3.30	6.70	-13	-21.16
	2509.8	H	-82.48	-41.95	3.97	7.43	-13	-38.49
	2509.8	V	-78.17	-35.52	3.97	7.43	-13	-32.06
	3346.4	H	-65.26	-61.86	4.63	7.19	-13	-59.31
	3346.4	V	-66.45	-62.14	4.63	7.19	-13	-59.59
	4183	H	-67.48	-61.49	5.19	8.15	-13	-58.53
	4183	V	-68.34	-62.72	5.19	8.15	-13	-59.76
	5019.6	H	-67.85	-59.14	6.19	8.87	-13	-56.46
	5019.6	V	-67.77	-59.89	6.19	8.87	-13	-57.21
	5856.2	H	-69.32	-57.42	7.28	9.57	-13	-55.13
	5856.2	V	-69.33	-57.3	7.28	9.57	-13	-55.01
	6692.8	H	-70.02	-53.08	7.47	9.81	-13	-50.74
	6692.8	V	-68.16	-51.51	7.47	9.81	-13	-49.17
GSM 850 Band; GPRS Mode; High Channel (251)	7529.4	H	-71.22	-48.88	8.31	9.02	-13	-48.17
	7529.4	V	-72.37	-52.59	8.31	9.02	-13	-51.88
	8366	H	-73.02	-49.97	8.56	9.22	-13	-49.31
	8366	V	-73.88	-49.94	8.56	9.22	-13	-49.28
	1697.6	H	-66.58	-29.79	3.18	6.70	-13	-26.27
	1697.6	V	-60.92	-23.84	3.18	6.70	-13	-20.32
	2546.4	H	-84.02	-42.54	4.09	7.43	-13	-39.20
	2546.4	V	-82.91	-39.32	4.09	7.43	-13	-35.98
	3395.2	H	-65.98	-61.28	4.84	7.19	-13	-58.94
	3395.2	V	-66.15	-59.64	4.84	7.19	-13	-57.30
	4244	H	-68.49	-62.16	5.00	8.37	-13	-58.79
	4244	V	-68.05	-62.06	5.00	8.37	-13	-58.69
	5092.8	H	-67.59	-58.08	6.25	8.87	-13	-55.46
	5092.8	V	-68.95	-60.09	6.25	8.87	-13	-57.47
	5941.6	H	-69.72	-55.93	7.03	9.53	-13	-53.43
	5941.6	V	-70.08	-57.52	7.03	9.53	-13	-55.02
6790.4	H	-69.69	-53.02	7.71	9.55	-13	-51.18	
6790.4	V	-68.52	-51.45	7.71	9.55	-13	-49.61	
7639.2	H	-71.66	-50.34	7.87	9.20	-13	-49.01	
7639.2	V	-71.36	-51.32	7.87	9.20	-13	-49.99	
8488	H	-73.47	-48.52	8.57	9.13	-13	-47.97	
8488	V	-73.28	-48.66	8.57	9.13	-13	-48.11	

F=B-C+D

**Worst Case Spurious Measurements – GSM 1900 Band – GPRS Mode**

Radiated Spurious Emissions Measurement								
Test Engineer: J. Centers Test Date: 2/6/2012 Temp. / Humidity / Pressure: 22.9C/24.6%/988.8mbar Bandwidth Settings: RBW = VBW = 1MHz Notes: Spurious emissions not reported here were below the measurement noise floor.								
Band/Channel	Spurious Frequency (MHz)	Polarity	A Device Reading (dBm)	B Signal Generator Level (dBm)	C Cable Loss (dB)	D Tx Antenna Gain (dBd)	E Limit (dBm)	F Radiated Spurious Emission Level (dBm)
GSM 1900 Band; GPRS Mode; Low Channel (512)	3700.4	H	-38.14	-31.33	4.85	7.07	-13	-29.11
	3700.4	V	-37.42	-30.44	4.85	7.07	-13	-28.22
	5550.6	H	-61.08	-48.78	6.91	8.48	-13	-47.21
	5550.6	V	-57.76	-46.25	6.91	8.48	-13	-44.68
	7400.8	H	-70.07	-50.54	7.75	8.72	-13	-49.57
	7400.8	V	-70.02	-53.35	7.75	8.72	-13	-52.38
	9251	H	-74.46	-50.58	9.21	9.41	-13	-50.39
	9251	V	-72.18	-50.64	9.21	9.41	-13	-50.45
GSM 1900 Band; GPRS Mode; Mid Channel (661)	11101.2	H	-73.83	-43.97	10.47	10.70	-13	-43.74
	11101.2	V	-73.13	-45.02	10.47	10.70	-13	-44.79
	3760	H	-44.06	-36.82	5.20	7.07	-13	-34.95
	3760	V	-42.99	-36.09	5.20	7.07	-13	-34.22
	5640	H	-63.37	-51.5	7.09	8.84	-13	-49.75
	5640	V	-59.21	-48.13	7.09	8.84	-13	-46.38
	7520	H	-71.4	-51.8	8.01	9.02	-13	-50.79
	7520	V	-68.2	-50.1	8.01	9.02	-13	-49.09
GSM 1900 Band; GPRS Mode; High Channel (810)	9400	H	-74.6	-49.38	9.15	9.52	-13	-49.01
	9400	V	-75.28	-52.95	9.15	9.52	-13	-52.58
	11280	H	-74.03	-44.19	10.16	10.65	-13	-43.71
	11280	V	-74.69	-47.03	10.16	10.65	-13	-46.55
	3819.6	H	-48.59	-41.07	5.00	6.73	-13	-39.34
	3819.6	V	-49.2	-43.18	5.00	6.73	-13	-41.45
	5729.4	H	-66.17	-52.74	7.06	9.27	-13	-50.53
	5729.4	V	-63.17	-51.6	7.06	9.27	-13	-49.39
7639.2	H	-76.86	-55.05	7.87	9.20	-13	-53.72	
7639.2	V	-70.81	-51.91	7.87	9.20	-13	-50.58	
9549	H	-74.63	-48.98	8.41	9.77	-13	-47.62	
9549	V	-74.94	-52.15	8.41	9.77	-13	-50.79	
11458.8	H	-74.49	-46.03	9.51	10.54	-13	-45.00	
11458.8	V	-74.07	-48.17	9.51	10.54	-13	-47.14	

F=B-C+D

**Worst Case Spurious Measurements – GSM 850 Band – EDGE Mode**

Radiated Spurious Emissions Measurement								
Test Engineer: J. Centers Test Date: 2/6/2012 Temp. / Humidity / Pressure: 22.9C/24.6%/988.8mbar Bandwidth Settings: RBW = VBW = 1MHz Notes: Spurious emissions not reported here were below the measurement noise floor.								
Band/Channel	Spurious Frequency (MHz)	Polarity	A Device Reading (dBm)	B Signal Generator Level (dBm)	C Cable Loss (dB)	D Tx Antenna Gain (dBd)	E Limit (dBm)	F Radiated Spurious Emission Level (dBm)
GSM 850 Band; EDGE Mode; Low Channel (128)	1648.4	H	-70.17	-34.08	3.26	6.70	-13	-30.64
	1648.4	V	-63.38	-28.31	3.26	6.70	-13	-24.87
	2472.6	H	-87.23	-47.27	4.17	7.16	-13	-44.28
	2472.6	V	-86.42	-44.51	4.17	7.16	-13	-41.52
	3296.8	H	-67.06	-63.35	4.58	7.14	-13	-60.79
	3296.8	V	-67.14	-60.84	4.58	7.14	-13	-58.28
	4121	H	-68.96	-62.43	5.33	8.15	-13	-59.61
	4121	V	-66.9	-59.43	5.33	8.15	-13	-56.61
	4945.2	H	-67.54	-59.44	5.82	8.80	-13	-56.46
GSM 850 Band; EDGE Mode; Mid Channel (190)	4945.2	V	-66.83	-59.27	5.82	8.80	-13	-56.29
	1673.2	H	-71.31	-34.85	3.30	6.70	-13	-31.45
	1673.2	V	-66.32	-30.15	3.30	6.70	-13	-26.75
	2509.8	H	-88.17	-47.64	3.97	7.43	-13	-44.18
	2509.8	V	-84.76	-42.11	3.97	7.43	-13	-38.65
	3346.4	H	-65.73	-62.33	4.63	7.19	-13	-59.78
	3346.4	V	-66.23	-61.92	4.63	7.19	-13	-59.37
	4183	H	-67.2	-61.21	5.19	8.15	-13	-58.25
	4183	V	-67.39	-61.77	5.19	8.15	-13	-58.81
GSM 850 Band; EDGE Mode; High Channel (251)	5019.6	H	-67.6	-58.89	6.19	8.87	-13	-56.21
	5019.6	V	-67.02	-59.14	6.19	8.87	-13	-56.46
	1697.6	H	-72.9	-36.11	3.18	6.70	-13	-32.59
	1697.6	V	-69.43	-32.35	3.18	6.70	-13	-28.83
	2546.4	H	-88.57	-47.09	4.09	7.43	-13	-43.75
	2546.4	V	-87.9	-44.31	4.09	7.43	-13	-40.97
	3395.2	H	-65.91	-61.21	4.84	7.19	-13	-58.87
	3395.2	V	-65.51	-59	4.84	7.19	-13	-56.66
	4244	H	-67.17	-60.84	5.00	8.37	-13	-57.47
4244	V	-67.63	-61.64	5.00	8.37	-13	-58.27	
5092.8	H	-67.28	-57.77	6.25	8.87	-13	-55.15	
5092.8	V	-67.28	-58.42	6.25	8.87	-13	-55.80	
								F=B-C+D



**Worst Case Spurious Measurements – GSM 1900 Band – EDGE Mode**

**Radiated Spurious Emissions Measurement**

Test Engineer: J. Centers  
 Test Date: 2/6/2012  
 Temp. / Humidity / Pressure: 22.9C/24.6%/988.8mbar  
 Bandwidth Settings: RBW = VBW = 1MHz

Notes: Spurious emissions not reported here were below the measurement noise floor.

			A	B	C	D	E	F
Band/Channel	Spurious Frequency (MHz)	Polarity	Device Reading (dBm)	Signal Generator Level (dBm)	Cable Loss (dB)	Tx Antenna Gain (dBd)	Limit (dBm)	Radiated Spurious Emission Level (dBm)
GSM 1900 Band; EDGE Mode; Low Channel (512)	3700.4	H	-38.18	-31.37	4.85	7.07	-13	-29.15
	3700.4	V	-36.5	-29.52	4.85	7.07	-13	-27.30
	5550.6	H	-61.03	-48.73	6.91	8.48	-13	-47.16
	5550.6	V	-57.49	-45.98	6.91	8.48	-13	-44.41
GSM 1900 Band; EDGE Mode; Mid Channel (661)	3760	H	-43.38	-36.14	5.20	7.07	-13	-34.27
	3760	V	-42.47	-35.57	5.20	7.07	-13	-33.70
	5640	H	-63.77	-51.9	7.09	8.84	-13	-50.15
	5640	V	-60.38	-49.3	7.09	8.84	-13	-47.55
GSM 1900 Band; EDGE Mode; High Channel (810)	3819.6	H	-49.7	-42.18	5.00	6.73	-13	-40.45
	3819.6	V	-50.07	-44.05	5.00	6.73	-13	-42.32
	5729.4	H	-66.14	-52.71	7.06	9.27	-13	-50.50
	5729.4	V	-65.38	-53.81	7.06	9.27	-13	-51.60

F=B-C+D

## 9 Frequency Stability

### 9.1 Test Limits

#### § 2.1055, §22.355, §24.235

The frequency stability of the transmitter was required to maintain a  $\pm 2.5$ ppm tolerance.

### 9.2 Test Procedure

The equipment under test was connected to an AC variac and the RF output was connected to a Base Station Simulator. The Base Station Simulator was set to force the EUT to its maximum power setting. The EUT was placed inside the temperature chamber. The DC leads and RF output cable exited the chamber through an opening made for that purpose. After the temperature stabilized for approximately 30 minutes, the frequency error was read from the base station simulator. At 20C the input voltage was varied from 85% to 115% and the frequency stability vs input voltage was recorded.

### 9.3 Test Equipment Used:

Description	Serial Number	Manufacturer	Model	Cal. Date	Cal. Due
Base Station Simulator	3101	Rohde & Schwarz	CMU200	6/1/2011	6/1/2012
Environmental Chamber	29410	Thermotron	SE-1000-5-5	4/6/2011	4/6/2012
Multimeter	1705	Fluke	87	3/9/2011	3/9/2012

**9.4 Results:**

The tables below show the frequency stability data for both Cell and PCS Bands. In both cases the test sample met the  $\pm 2.5$ ppm limit.

**Frequency Stability for GSM 850 Band – GPRS Mode**

**Operating Frequency:** 836,520,000 Hz

**Channel:** 190

**Reference Voltage:** 115 VAC

**Deviation Limit:** 2.5 ppm

**Notes:** Frequency Stability in GSM 850 Band, GPRS Mode

Voltage (%)	Voltage (VAC)	Temp (°C)	Frequency Error (Hz)	Deviation (%)	Deviation (ppm)
100%	115	-30	19	0.0000023	0.0227
100%	115	-20	22	0.0000026	0.0263
100%	115	-10	27	0.0000032	0.0323
100%	115	0	19	0.0000023	0.0227
100%	115	10	17	0.0000020	0.0203
100%	115	20	20	0.0000024	0.0239
100%	115	30	24	0.0000029	0.0287
100%	115	40	16	0.0000019	0.0191
100%	115	50	19	0.0000023	0.0227
100%	115	60	10	0.0000012	0.0120
115%	138	20	24	0.0000029	0.0287
85%	93.5	20	22	0.0000026	0.0263

**Frequency Stability for GSM 1900 Band – GPRS Mode**

**Operating Frequency:** 1,880,000,000 Hz

**Channel:** 661

**Reference Voltage:** 115 VAC

**Deviation Limit:** 2.5 ppm

**Notes:** Frequency Stability in GSM 1900 Band, GPRS Mode

Voltage (%)	Voltage (VAC)	Temp (°C)	Frequency Error (Hz)	Deviation (%)	Deviation (ppm)
100%	115	-30	18	0.0000010	0.0096
100%	115	-20	20	0.0000011	0.0106
100%	115	-10	22	0.0000012	0.0117
100%	115	0	31	0.0000016	0.0165
100%	115	10	26	0.0000014	0.0138
100%	115	20	27	0.0000014	0.0144
100%	115	30	31	0.0000016	0.0165
100%	115	40	24	0.0000013	0.0128
100%	115	50	33	0.0000018	0.0176
100%	115	60	39	0.0000021	0.0207
115%	138	20	38	0.0000020	0.0202
85%	93.5	20	46	0.0000024	0.0245

**Frequency Stability for GSM 850 Band – EDGE Mode**

**Operating Frequency:** 836,520,000 Hz

**Channel:** 190

**Reference Voltage:** 115 VAC

**Deviation Limit:** 2.5 ppm

**Notes:** Frequency Stability in GSM 850 Band, EDGE Mode

Voltage (%)	Voltage (VAC)	Temp (°C)	Frequency Error (Hz)	Deviation (%)	Deviation (ppm)
100%	115	-30	21	0.0000025	0.0251
100%	115	-20	19	0.0000023	0.0227
100%	115	-10	22	0.0000026	0.0263
100%	115	0	15	0.0000018	0.0179
100%	115	10	18	0.0000022	0.0215
100%	115	20	20	0.0000024	0.0239
100%	115	30	12	0.0000014	0.0143
100%	115	40	15	0.0000018	0.0179
100%	115	50	13	0.0000016	0.0155
100%	115	60	14	0.0000017	0.0167
115%	138	20	18	0.0000022	0.0215
85%	93.5	20	21	0.0000025	0.0251

**Frequency Stability for GSM 1900 Band – EDGE Mode**

**Operating Frequency:** 1,880,000,000 Hz

**Channel:** 661

**Reference Voltage:** 115 VAC

**Deviation Limit:** 2.5 ppm

**Notes:** Frequency Stability in GSM 1900 Band, EDGE Mode

Voltage (%)	Voltage (VAC)	Temp (°C)	Frequency Error (Hz)	Deviation (%)	Deviation (ppm)
100%	115	-30	28	0.0000015	0.0149
100%	115	-20	26	0.0000014	0.0138
100%	115	-10	33	0.0000018	0.0176
100%	115	0	32	0.0000017	0.0170
100%	115	10	28	0.0000015	0.0149
100%	115	20	34	0.0000018	0.0181
100%	115	30	29	0.0000015	0.0154
100%	115	40	30	0.0000016	0.0160
100%	115	50	36	0.0000019	0.0191
100%	115	60	35	0.0000019	0.0186
115%	138	20	37	0.0000020	0.0197
85%	93.5	20	32	0.0000017	0.0170

## 10 Radiated Spurious Emissions (Receiver)

### 10.1 Test Limits

§ 15.109: Except for Class A digital devices, the field strength of radiated emissions from unintentional radiators at a distance of 3 meters shall not exceed the following values:

Frequency of emission (MHz)	Field strength (microvolts/meter)	Field strength (dBuV/m)
30–88	100	40
88–216	150	43.5
216–960	200	46
Above 960	500	54

These limits are identical to those in RSS-GEN

### 10.2 Test Procedure

ANSI C63.4: 2009

### 10.3 Example of Field Strength Calculation Method:

The measured field strength was calculated by summing the readings taken from the spectrum analyzer with the appropriate correction factors associated with the antenna losses and cable losses. The calculation formula and sample calculations are listed below:

Formula:

$$FS = RA + AF + CF$$

FS = Field Strength in dB $\mu$ V/m

RA = Receiver Amplitude in dB $\mu$ V

AF = Antenna Factor in dB

CF = Cable Attenuation Factor in dB (Including preamplifier and filter attenuation)

Example Calculation:

$$RA = 19.48 \text{ dB}\mu\text{V}$$

$$AF = 18.52 \text{ dB}$$

$$CF = 0.78 \text{ dB}$$

$$FS = 19.48 + 18.52 + 0.78 = 38.78 \text{ dB}\mu\text{V/m}$$

$$\text{Level in } \mu\text{V/m} = \text{Common Antilogarithm} [(38.78 \text{ dB}\mu\text{V/m})/20] = 86.89 \mu\text{V/m}$$

**10.4 Test Equipment Used:**

Description	Serial Number	Manufacturer	Model	Cal. Date	Cal. Due
EMI Test Receiver	10887490.26	Rohde & Schwarz	ESI26	6/29/2011	6/29/2012
Preamplifier	SF456200904	Mini-Circuits	ZX60-3018G-S+	9/12/2011	9/12/2012
Biconnilog Antenna	00051864	ETS	3142C	12/20/2011	12/20/2012
Preamplifier	987410	Miteq	AFS44-00102000-30-10P-44	9/12/2011	9/12/2012
Horn Antenna	6556	ETS	3115	8/24/2011	8/24/2012
System Controller	121701-1	Sunol Sciences	SC99V	Calibrate at Time of Use	Calibrate at Time of Use

**10.5 Results:**

All spurious emissions with the test sample in receive mode were below the limits specified in Part 15.109 for a class B digital device and RSS-GEN Section 6.1.

Radiated Emissions										
<b>Test Engineer:</b> J. Centers		<b>Start Date:</b> 2/8/2011		<b>End Date:</b> 2/8/2012						
<b>Temperature:</b> 23.1C		<b>Humidity:</b> 25.50%		<b>Pressure:</b> 992.2mbar						
<b>Specification:</b> FCC Part 15B		<b>Test Limit:</b> Class B								
<b>Notes:</b> Receive Mode										
A	B	C	D	E	F	G	H	I	J	K
Frequency	Polarity (H/V)	Raw Reading (dBUV)	Cab. (dB)	Ant. (dB)	Corr. Reading. (dBUV/m)	Limit (dBUV/m)	Delta (dB)	RBW / Detector	Test Distance	Results
36.702 MHz	V	26.54	-16.02	14.28	24.79	40	-15.21	120kHz/QP	3m	Compliant
72.756 MHz	V	37.93	-15.68	6.6	28.85	40	-11.15	120kHz/QP	3m	Compliant
74.26 MHz	V	41.71	-15.66	6.73	32.77	40	-7.23	120kHz/QP	3m	Compliant
205.6 MHz	V	27.26	-14.62	10.66	23.3	43.52	-20.22	120kHz/QP	3m	Compliant
249.36 MHz	V	45.34	-14.38	12.39	43.35	46.02	-2.67	120kHz/QP	3m	Compliant
207.84 MHz	H	34.85	-14.59	10.89	31.15	43.52	-12.37	120kHz/QP	3m	Compliant
216.14 MHz	H	45.18	-14.55	11.38	42.01	46.02	-4.01	120kHz/QP	3m	Compliant
241.04 MHz	H	34.03	-14.43	12.22	31.82	46.02	-14.2	120kHz/QP	3m	Compliant
1.9042 GHz	V	44.26	-36.69	27	34.57	53.98	-19.41	1MHz/Avg	3m	Compliant
1.9042 GHz	H	41.82	-36.69	27	32.13	53.98	-21.85	1MHz/Avg	3m	Compliant
Calculations:					F = C + D + E		H = F - G			

**Peak Scan (Receive Mode) – 30MHz – 1GHz**

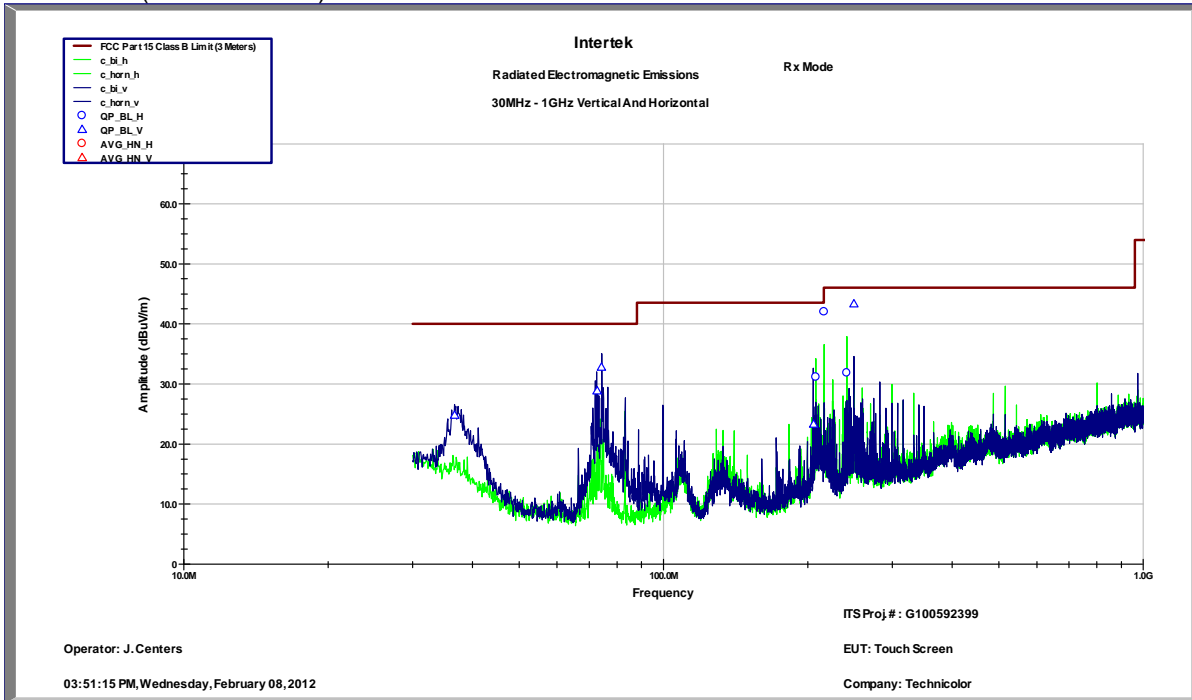

Peak Scan (Receive Mode) – 1GHz – 12GHz

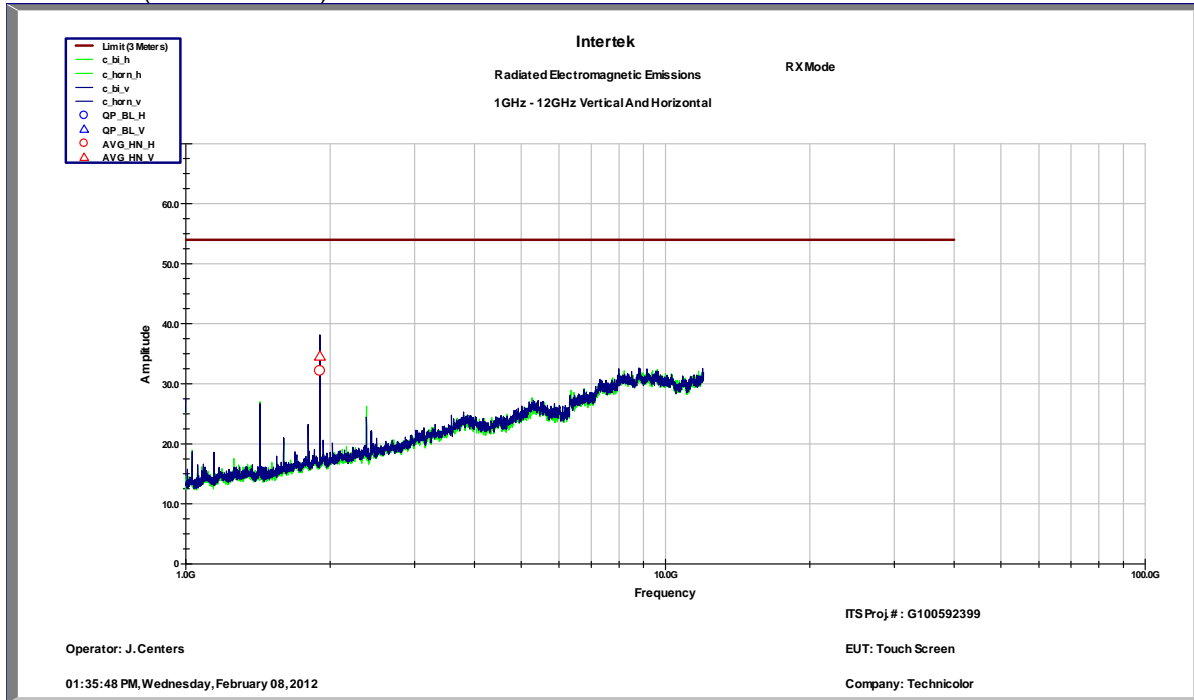



## 11 Measurement Uncertainty

The measured value related to the corresponding limit will be used to decide whether the equipment meets the requirements.

The measurement uncertainty figures were calculated and correspond to a coverage factor of  $k = 2$ , providing a confidence level of respectively 95.45 % in the case where the distributions characterizing the actual measurement uncertainties are normal (Gaussian).

Measurement uncertainty Table

Parameter	Uncertainty	Notes
Radiated emissions, 30 to 1000 MHz	+3.9dB	
Radiated emissions, 1 to 18 GHz	+4.2dB	
Radiated emissions, 18 to 40 GHz	+4.3dB	
Power Port Conducted emissions, 150kHz to 30 MHz	+2.8dB	

**12 Revision History**

Revision Level	Date	Report Number	Notes
0	2/22/2012	100592399LEX-001	Original Issue