



FCC Test Report

Equipment : Genie Air
Brand Name : AT&T DIRECTV
Model No. : HS17-100
FCC ID : G95HS17
Standard : 47 CFR FCC Part 15.247
Operating Band : 2400 MHz – 2483.5 MHz
Function : Point-to-multipoint; Point-to-point
Applicant : Technicolor Connected Home USA LLC
5030 Sugarloaf Parkway Building 6 Lawrenceville
Georgia United States 30044
Manufacturer : Technicolor Connected Home USA LLC
5030 Sugarloaf Parkway Building 6 Lawrenceville
Georgia United States 30044

The product sample received on Nov. 03, 2016 and completely tested on Nov. 30, 2016. We, SPORTON, would like to declare that the tested sample has been evaluated in accordance with the procedures given in ANSI C63.10-2013 and shown compliance with the applicable technical standards.

The test results in this report apply exclusively to the tested model / sample. Without written approval of SPORTON INTERNATIONAL INC., the test report shall not be reproduced except in full.

Sam Chen
SPORTON INTERNATIONAL INC.





Table of Contents

- 1 GENERAL DESCRIPTION5**
- 1.1 Information.....5
- 1.2 Testing Applied Standards8
- 1.3 Testing Location Information8
- 1.4 Measurement Uncertainty9
- 2 TEST CONFIGURATION OF EUT10**
- 2.1 Test Channel Mode10
- 2.2 The Worst Case Measurement Configuration11
- 2.3 EUT Operation during Test12
- 2.4 Accessories12
- 2.5 Support Equipment.....12
- 2.6 Test Setup Diagram13
- 3 TRANSMITTER TEST RESULT16**
- 3.1 AC Power-line Conducted Emissions16
- 3.2 DTS Bandwidth18
- 3.3 Maximum Conducted Output Power19
- 3.4 Power Spectral Density21
- 3.5 Emissions in Non-restricted Frequency Bands23
- 3.6 Emissions in Restricted Frequency Bands.....24
- 4 TEST EQUIPMENT AND CALIBRATION DATA28**

APPENDIX A. TEST RESULTS OF AC POWER-LINE CONDUCTED EMISSIONS

APPENDIX B. TEST RESULTS OF DTS BANDWIDTH

APPENDIX C. TEST RESULTS OF MAXIMUM CONDUCTED OUTPUT POWER

APPENDIX D. TEST RESULTS OF POWER SPECTRAL DENSITY

APPENDIX E. TEST RESULTS OF EMISSIONS IN NON-RESTRICTED FREQUENCY BANDS

APPENDIX F. TEST RESULTS OF EMISSIONS IN RESTRICTED FREQUENCY BANDS

APPENDIX G. TEST PHOTOS



Summary of Test Result

Conformance Test Specifications				
Report Clause	Ref. Std. Clause	Description	Limit	Result
1.1.2	15.203	Antenna Requirement	FCC 15.203	Complied
3.1	15.207	AC Power-line Conducted Emissions	FCC 15.207	Complied
3.2	15.247(a)	DTS Bandwidth	≥500kHz	Complied
3.3	15.247(b)	Maximum Conducted Output Power	Power [dBm]:30	Complied
3.4	15.247(e)	Power Spectral Density	PSD [dBm/3kHz]:8	Complied
3.5	15.247(d)	Emissions in Non-restricted Frequency Bands	Non-Restricted Bands: > 30 dBc	Complied
3.6	15.247(d)	Emissions in Restricted Frequency Bands	Restricted Bands: FCC 15.209	Complied



Revision History

Report No.	Version	Description	Issued Date
FR602141AC	Rev. 01	Initial issue of report	Dec. 08, 2016



1 General Description

1.1 Information

1.1.1 RF General Information

Frequency Range (MHz)	IEEE Std.	Ch. Frequency (MHz)	Channel Number
2400-2483.5	802.15.4	2425-2475	15-25 [11]

Band	Mode	BWch (MHz)	Nant
2.4G	Zigbee	5	1

Note:

- ♦ 2.4G is the 2.4GHz Band (2.4-2.4835GHz).
- ♦ Zigbee uses a O-QPSK (250kbps) modulation for DSSS.
- ♦ BWch is the nominal channel bandwidth.
- ♦ Nss-Min is the minimum number of spatial streams.
- ♦ Nant is the number of outputs. e.g., 2(2,3) means have 2 outputs for port 2 and port 3. 2 means have 2 outputs for port 1 and port 2.

1.1.2 Antenna Information

Ant.	Chain	Brand	P/N	Antenna Type	Connector
1	1	Airgain	N24X2B2T1YE-W70U	PIFA Antenna	U.FL
2	2	Airgain	N24X2BTYN-B120U	PIFA Antenna	U.FL
3	3	Airgain	N5X35BYN-E125U	PIFA Antenna	U.FL
4	4	Airgain	N5X35B2YN-R110U	PIFA Antenna	U.FL
5	5	Airgain	N5X35BYN-A110U	PIFA Antenna	U.FL
6	6	Airgain	N5X35BT2YW-G120U	PIFA Antenna	U.FL
7	7	-	-	PCB printed IFA	-
8	8	-	-	PCB printed IFA	-

Frequency (MHz)	Antenna Gain (dBi)			
	Ant. 1	Ant. 2	Ant. 7	Ant. 8
2.4G	4.60	4.60	-	-
Zigbee	-	-	4.00	4.00

Frequency (MHz)	Composite Gain (dBi)				Max Composite Gain (dBi)			
	Ant. 3	Ant. 4	Ant. 5	Ant. 6	4T1S	4T2S	4T3S	4T4S
UNII-1	2.69	2.86	4.02	4.30	6.82	3.96	2.23	1.26
UNII-3	2.48	2.24	2.49	2.50	6.13	3.12	2.06	0.29

Note1: The EUT has eight antennas.

Note2: Ant. 1~Ant. 8 connect to chain 1~chain 8.

For 2.4GHz WLAN function:

For IEEE 802.11b/g mode (1TX/1RX)

The EUT supports the antenna with TX and RX diversity functions.

Both Chain 1 and Chain 2 support transmit and receive functions, but only one of them will be used at one time.

The Chain 1 generated the worst case, so it was selected to test and record in the report.

For IEEE 802.11n mode (2TX/2RX)

Chain 1 and Chain 2 can be used as transmitting/receiving antenna.

Chain 1 and Chain 2 could transmit/receive simultaneously.



For 5GHz WLAN function:

For IEEE 802.11n/ac mode (4TX/4RX)

Chain 3, Chain 4, Chain 5 and Chain 6 can be used as transmitting/receiving antenna.

Chain 3, Chain 4, Chain 5 and Chain 6 could transmit/receive simultaneously.

For Zigbee function:

For Zigbee mode (1TX/1RX)

The EUT supports the antenna with TX and RX diversity functions.

Both Chain 7 and Chain 8 support transmit and receive functions, but only one of them will be used at one time.

The Chain 8 generated the worst case, so it was selected to test and record in the report.

1.1.3 Mode Test Duty Cycle

Mode	DC	T(s)	VBW(Hz) ≥ 1/T
Zigbee	1	n/a (DC>=0.98)	n/a (DC>=0.98)

1.1.4 EUT Operational Condition

EUT Power Type	From Power Adapter		
Beamforming Function	<input checked="" type="checkbox"/>	With beamforming for 802.11n/ac in 5GHz	<input type="checkbox"/> Without beamforming



1.2 Testing Applied Standards

According to the specifications of the manufacturer, the EUT must comply with the requirements of the following standards:

- ◆ 47 CFR FCC Part 15
- ◆ ANSI C63.10-2013
- ◆ FCC KDB 558074 D01 v03r05
- ◆ FCC KDB 662911 D01 v02r01
- ◆ FCC KDB 412172 D01 v01

1.3 Testing Location Information

Testing Location		
<input type="checkbox"/>	HWA YA	ADD : No. 52, Hwa Ya 1st Rd., Kwei-Shan Hsiang, Tao Yuan Hsien, Taiwan, R.O.C. TEL : 886-3-327-3456 FAX : 886-3-318-0055
<input checked="" type="checkbox"/>	JHUBEI	ADD : No.8, Lane 724, Bo-ai St., Jhubei City, HsinChu County 302, Taiwan, R.O.C. TEL : 886-3-656-9065 FAX : 886-3-656-9085

Test Condition	Test Site No.	Test Engineer	Test Environment	Test Date
RF Conducted	TH01-CB	Andy Tsai	25°C / 60%	Nov. 29, 2016
Radiated	03CH01-CB	Jeff Wu / Steven Liang / Welson Chen / Nyle Chang / Paul Chen	25°C / 60%	Nov. 06, 2016 ~Nov. 30, 2016
AC Conduction	CO01-CB	Da Deng	23°C / 61%	Nov. 29, 2016

Test site Designation No. TW0006 with FCC.
 Test site registered number IC 4086D with Industry Canada.



1.4 Measurement Uncertainty

ISO/IEC 17025 requires that an estimate of the measurement uncertainties associated with the emissions test results be included in the report. The measurement uncertainties given below are based on a 95% confidence level (based on a coverage factor (k=2))

Test Items	Uncertainty	Remark
Conducted Emission (150kHz ~ 30MHz)	3.2 dB	Confidence levels of 95%
Radiated Emission (30MHz ~ 1,000MHz)	3.6 dB	Confidence levels of 95%
Radiated Emission (1GHz ~ 18GHz)	3.7 dB	Confidence levels of 95%
Radiated Emission (18GHz ~ 40GHz)	3.5 dB	Confidence levels of 95%
Conducted Emission	1.7 dB	Confidence levels of 95%



2 Test Configuration of EUT

2.1 Test Channel Mode

Band	Mode	BWch (MHz)	Nss-Min	Nant	Ch. (MHz)	Range	Power Setting
2.4G	Zigbee	5	1	1(2)	2425	L	7
2.4G	Zigbee	5	1	1(2)	2450	M	7
2.4G	Zigbee	5	1	1(2)	2475	H	7

Note:

- ♦ Test range channel consist of L (Low Ch.), M (Middle Ch.), H (High Ch.), S (Single Ch.) and C (Straddle Band Ch.).

2.2 The Worst Case Measurement Configuration

The Worst Case Mode for Following Conformance Tests	
Tests Item	AC power-line conducted emissions
Condition	AC power-line conducted measurement for line and neutral
Operating Mode	CTX
1	EUT in Y axis - Zigbee function
2	EUT in Y axis - WLAN 2.4G function
3	EUT in Y axis - WLAN 5G function
For operating mode 3 is the worst case and it was record in this test report.	

The Worst Case Mode for Following Conformance Tests	
Tests Item	DTS Bandwidth Maximum Conducted Output Power Power Spectral Density Emissions in Non-restricted Frequency Bands
Test Condition	Conducted measurement at transmit chains

The Worst Case Mode for Following Conformance Tests	
Tests Item	Emissions in Restricted Frequency Bands
Test Condition	Radiated measurement If EUT consist of multiple antenna assembly (multiple antenna are used in EUT regardless of spatial multiplexing MIMO configuration), the radiated test should be performed with highest antenna gain of each antenna type.
Operating Mode < 1GHz	CTX
1	EUT in Y axis - Zigbee function
2	EUT in Y axis - WLAN 2.4G function
3	EUT in Y axis - WLAN 5G function
For operating mode 2 is the worst case and it was record in this test report.	
Operating Mode > 1GHz	CTX
1	EUT in Y axis

The Worst Case Mode for Following Conformance Tests	
Tests Item	Simultaneous Transmission Analysis
Operating Mode	
1	WLAN 2.4GHz function + WLAN 5GHz function + Zigbee function
Refer to Sporton Test Report No.: FA6O2141 for Co-location RF Exposure Evaluation.	

2.3 EUT Operation during Test

The EUT was programmed to be in continuously transmitting mode.

2.4 Accessories

Accessories			
Equipment Name	Brand Name	Model Name	Rating
AC Adapter	DIRECTV	EPS17R0-15	INPUT: 120V~1.8A 60Hz OUTPUT: 25.2V-2.86A 72W
Other			
Equipment Name	Brand Name	Model Name	Remark
Hard Drive	SEAGATE	1ET64-671	2TB

2.5 Support Equipment

For Test Site No: CO01-CB

Support Equipment				
No.	Equipment	Brand Name	Model Name	FCC ID
1	NB	DELL	E6430	DoC
2	Flash disk3.0	ADATA	C103	DoC
3	SIM Card	DIRECTV	NA	DoC

For Test Site No: 03CH01-CB (above 1GHz)

Support Equipment				
No.	Equipment	Brand Name	Model Name	FCC ID
1	NB	DELL	E4300	DoC

For Test Site No: TH01-CB

Support Equipment				
No.	Equipment	Brand Name	Model Name	FCC ID
1	NB	DELL	E4300	DoC

2.6 Test Setup Diagram

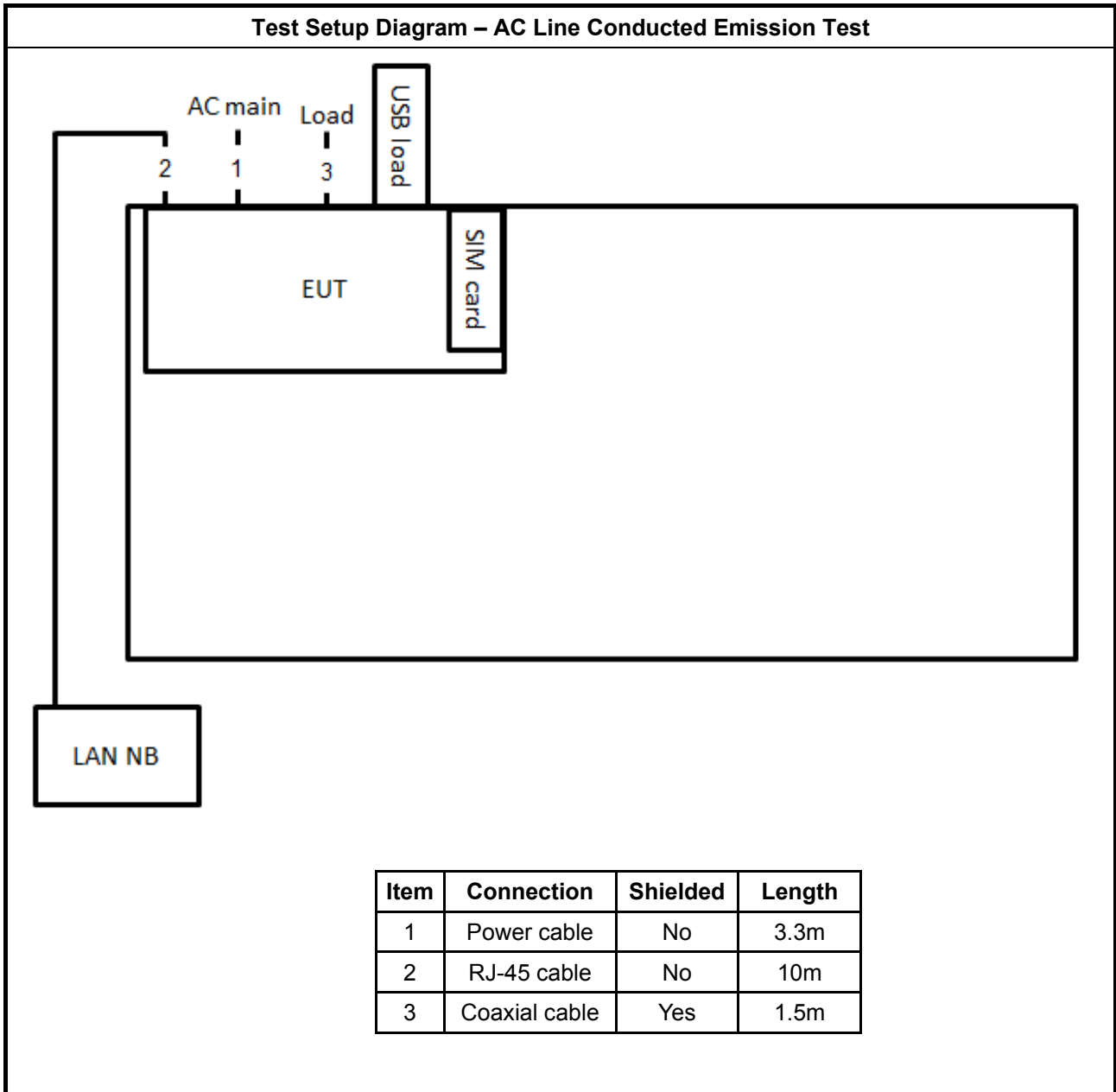

Test Setup Diagram - Radiated Test < 1GHz

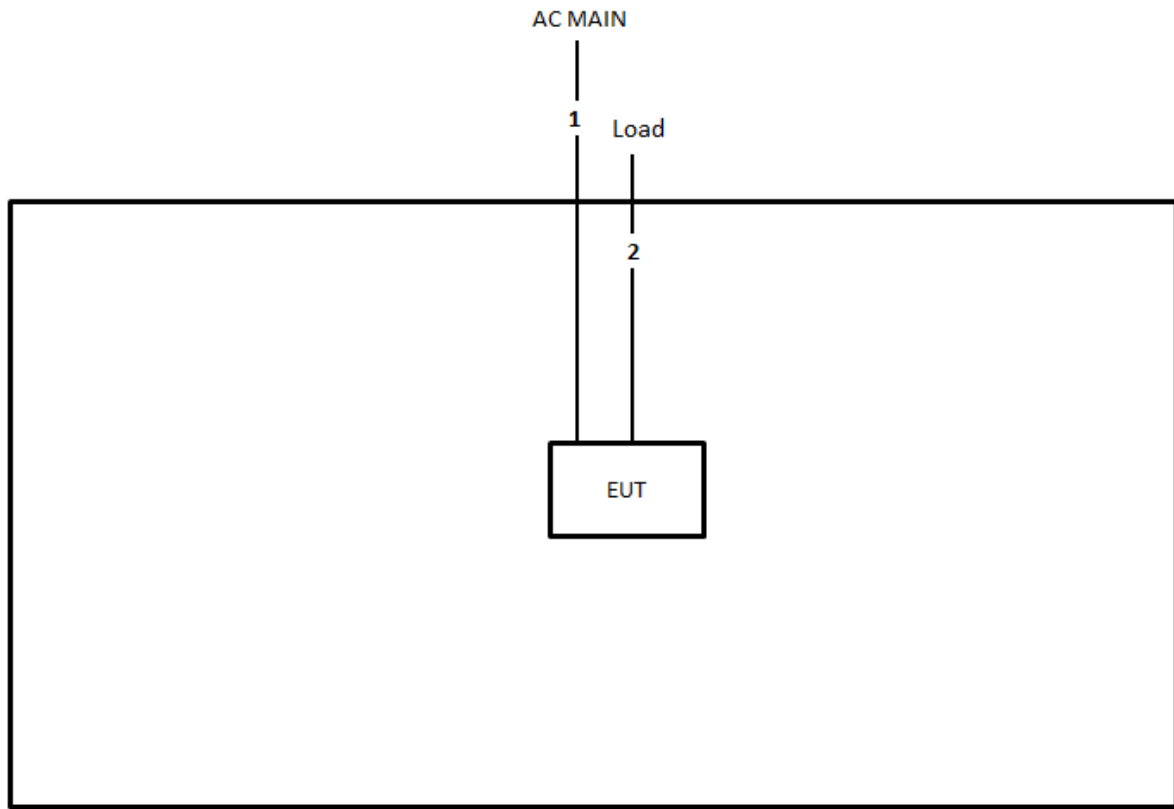

Item	Connection	Shielded	Length
1	Power cable	No	3.3m
2	Coaxial cable	Yes	10m

Test Setup Diagram - Radiated Test > 1GHz

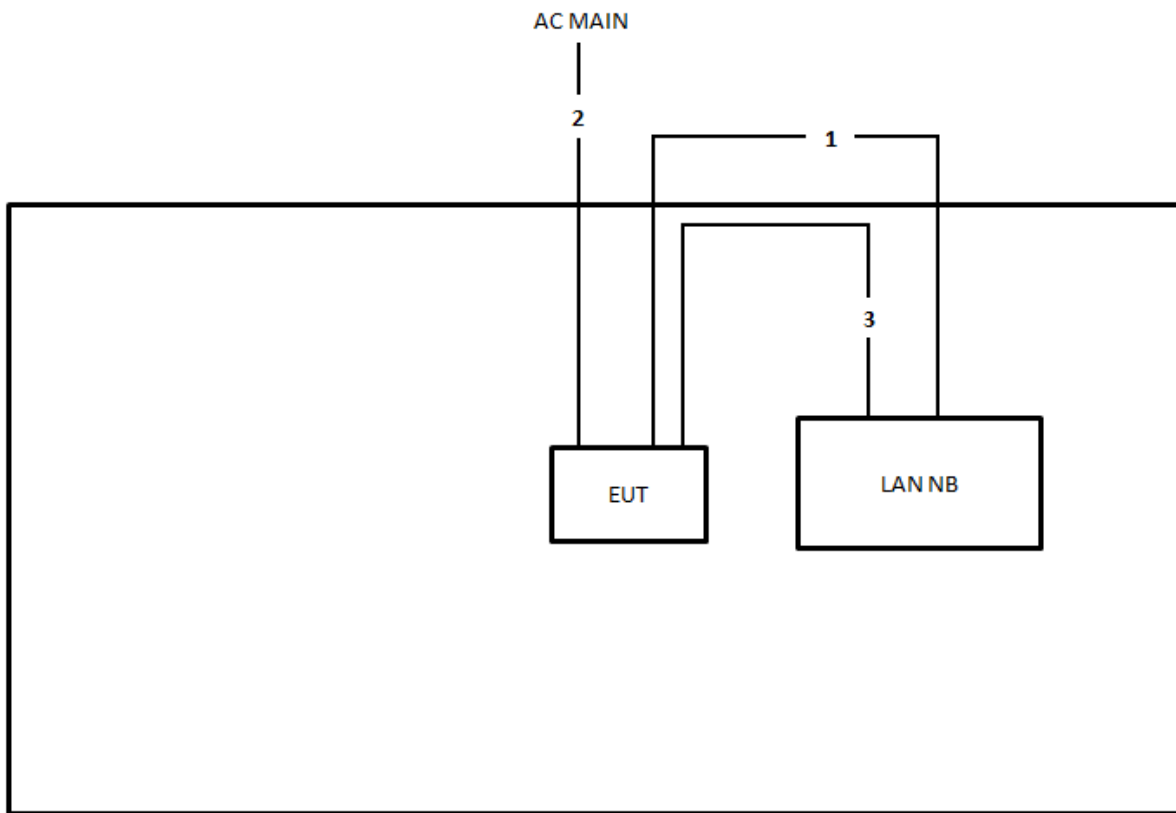

Item	Connection	Shielded	Length
1	RJ-45 cable	No	3m
2	Power cable	No	3.3m
3	console cable	Yes	2.1m

3 Transmitter Test Result

3.1 AC Power-line Conducted Emissions

3.1.1 AC Power-line Conducted Emissions Limit

AC Power-line Conducted Emissions Limit		
Frequency Emission (MHz)	Quasi-Peak	Average
0.15-0.5	66 - 56 *	56 - 46 *
0.5-5	56	46
5-30	60	50

Note 1: * Decreases with the logarithm of the frequency.

3.1.2 Measuring Instruments

Refer a test equipment and calibration data table in this test report.

3.1.3 Test Procedures

Test Method
<input checked="" type="checkbox"/> Refer as ANSI C63.10-2013, clause 6.2 for AC power-line conducted emissions.

3.1.4 Test Setup

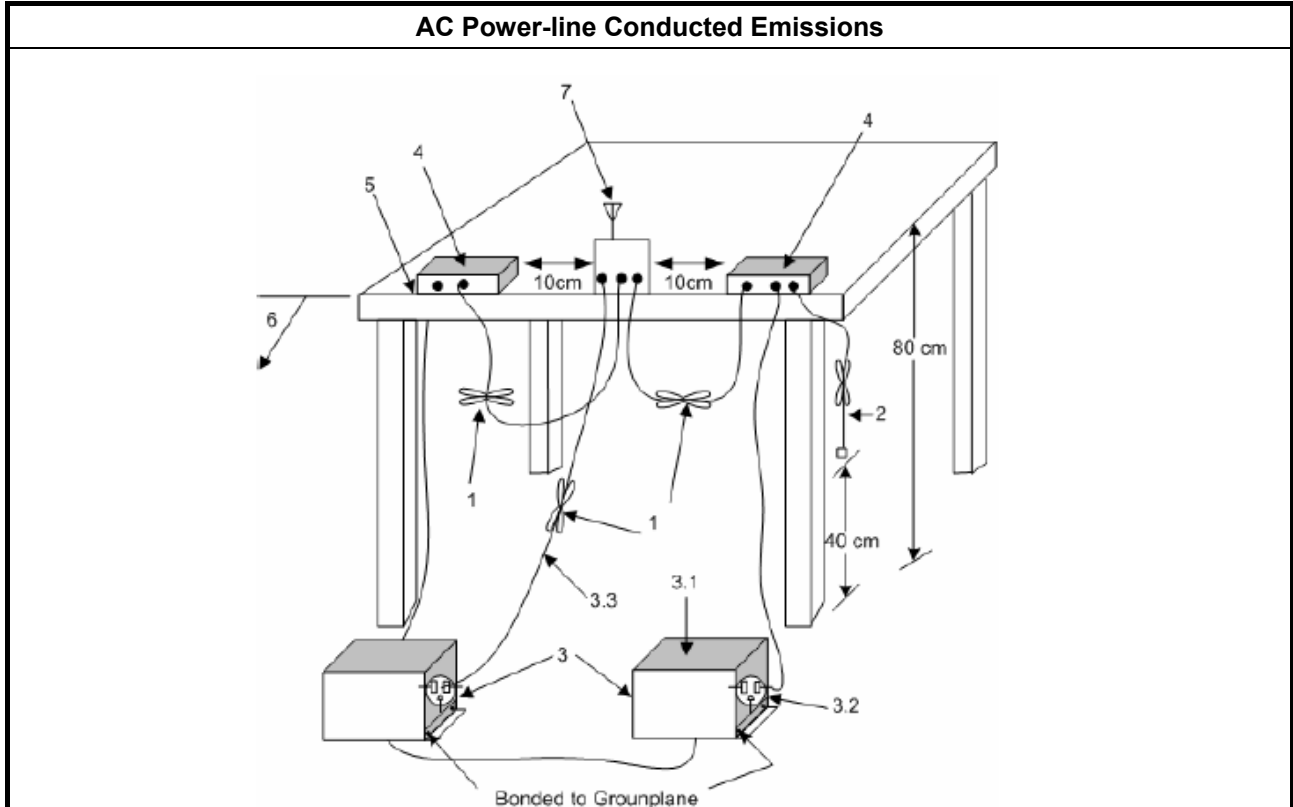



3.1.5 Test Result of AC Power-line Conducted Emissions

Refer as Appendix A

3.2 DTS Bandwidth

3.2.1 6dB Bandwidth Limit

6dB Bandwidth Limit
Systems using digital modulation techniques:
<ul style="list-style-type: none"> ▪ 6 dB bandwidth \geq 500 kHz.

3.2.2 Measuring Instruments

Refer a test equipment and calibration data table in this test report.

3.2.3 Test Procedures

Test Method
<ul style="list-style-type: none"> ▪ For the emission bandwidth shall be measured using one of the options below:
<input checked="" type="checkbox"/> Refer as FCC KDB 558074, clause 8.1 Option 1 for 6 dB bandwidth measurement.
<input type="checkbox"/> Refer as FCC KDB 558074, clause 8.2 Option 2 for 6 dB bandwidth measurement.
<input type="checkbox"/> Refer as ANSI C63.10, clause 6.9.1 for occupied bandwidth testing.

3.2.4 Test Setup

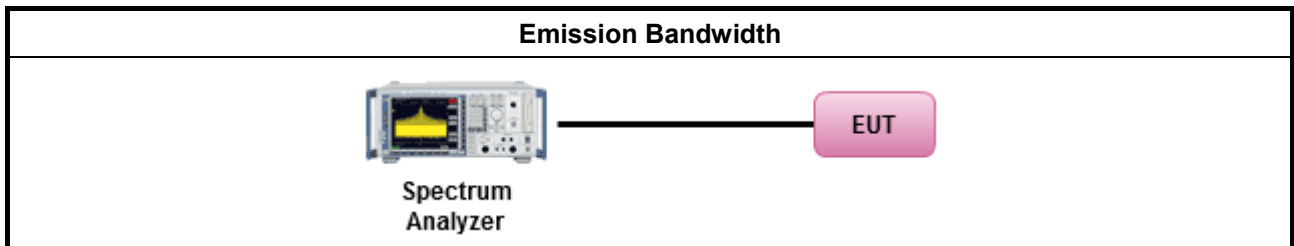

3.2.5 Test Result of Emission Bandwidth

Refer as Appendix B

3.3 Maximum Conducted Output Power

3.3.1 Maximum Conducted Output Power Limit

Maximum Conducted Output Power Limit	
	<ul style="list-style-type: none"> ▪ If $G_{TX} \leq 6$ dBi, then $P_{Out} \leq 30$ dBm (1 W)
	<ul style="list-style-type: none"> ▪ Point-to-multipoint systems (P2M): If $G_{TX} > 6$ dBi, then $P_{Out} = 30 - (G_{TX} - 6)$ dBm
	<ul style="list-style-type: none"> ▪ Point-to-point systems (P2P): If $G_{TX} > 6$ dBi, then $P_{Out} = 30 - (G_{TX} - 6)/3$ dBm
	<ul style="list-style-type: none"> ▪ Smart antenna system (SAS):
	<ul style="list-style-type: none"> - Single beam: If $G_{TX} > 6$ dBi, then $P_{Out} = 30 - (G_{TX} - 6)/3$ dBm
	<ul style="list-style-type: none"> - Overlap beam: If $G_{TX} > 6$ dBi, then $P_{Out} = 30 - (G_{TX} - 6)/3$ dBm
	<ul style="list-style-type: none"> - Aggregate power on all beams: If $G_{TX} > 6$ dBi, then $P_{Out} = 30 - (G_{TX} - 6)/3 + 8$ dB dBm
<p>P_{Out} = maximum peak conducted output power or maximum conducted output power in dBm, G_{TX} = the maximum transmitting antenna directional gain in dBi.</p>	

3.3.2 Measuring Instruments

Refer a test equipment and calibration data table in this test report.

3.3.3 Test Procedures

Test Method	
<ul style="list-style-type: none"> Maximum Peak Conducted Output Power 	
<input type="checkbox"/>	Refer as FCC KDB 558074, clause 9.1.1 Option 1 (RBW ≥ EBW method).
<input type="checkbox"/>	Refer as FCC KDB 558074, clause 9.1.2 Option 2 (peak power meter for VBW ≥ DTS BW)
<ul style="list-style-type: none"> Maximum Conducted Output Power 	
[duty cycle ≥ 98% or external video / power trigger]	
<input type="checkbox"/>	Refer as FCC KDB 558074, clause 9.2.2.2 Method AVGSA-1 (spectral trace averaging).
<input type="checkbox"/>	Refer as FCC KDB 558074, clause 9.2.2.3 Method AVGSA-1 Alt. (slow sweep speed)
duty cycle < 98% and average over on/off periods with duty factor	
<input type="checkbox"/>	Refer as FCC KDB 558074, clause 9.2.2.4 Method AVGSA-2 (spectral trace averaging).
<input type="checkbox"/>	Refer as FCC KDB 558074, clause 9.2.2.5 Method AVGSA-2 Alt. (slow sweep speed)
RF power meter and average over on/off periods with duty factor or gated trigger	
<input checked="" type="checkbox"/>	Refer as FCC KDB 558074, clause 9.2.3 Method AVGPM-G (using an RF average power meter).
<ul style="list-style-type: none"> For conducted measurement. 	
<ul style="list-style-type: none"> If the EUT supports multiple transmit chains using options given below: Refer as FCC KDB 662911, In-band power measurements. Using the measure-and-sum approach, measured all transmit ports individually. Sum the power (in linear power units e.g., mW) of all ports for each individual sample and save them. 	
<ul style="list-style-type: none"> If multiple transmit chains, EIRP calculation could be following as methods: $P_{total} = P_1 + P_2 + \dots + P_n$ (calculated in linear unit [mW] and transfer to log unit [dBm]) $EIRP_{total} = P_{total} + DG$ 	

3.3.4 Test Setup

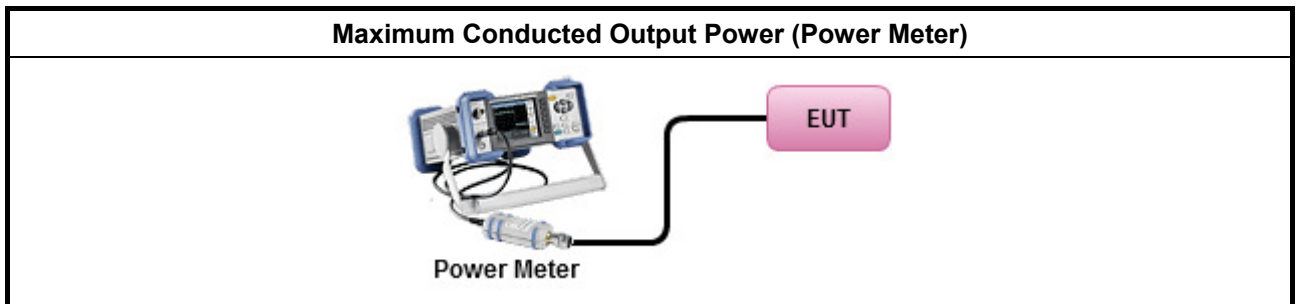

3.3.5 Test Result of Maximum Conducted Output Power

Refer as Appendix C

3.4 Power Spectral Density

3.4.1 Power Spectral Density Limit

Power Spectral Density Limit
<ul style="list-style-type: none"> ▪ Power Spectral Density (PSD) \leq 8 dBm/3kHz

3.4.2 Measuring Instruments

Refer a test equipment and calibration data table in this test report.

3.4.3 Test Procedures

Test Method
<ul style="list-style-type: none"> ▪ Peak power spectral density procedures that the same method as used to determine the conducted output power. If maximum peak conducted output power was measured to demonstrate compliance to the output power limit, then the peak PSD procedure below (Method PKPSD) shall be used. If maximum conducted output power was measured to demonstrate compliance to the output power limit, then one of the average PSD procedures shall be used, as applicable based on the following criteria (the peak PSD procedure is also an acceptable option).
<input checked="" type="checkbox"/> Refer as FCC KDB 558074, clause 10.2 Method PKPSD (RBW=3-100kHz; Detector=peak). [duty cycle \geq 98% or external video / power trigger]
<input type="checkbox"/> Refer as FCC KDB 558074, clause 10.3 Method AVGPSD-1 (spectral trace averaging).
<input type="checkbox"/> Refer as FCC KDB 558074, clause 10.4 Method AVGPSD-2 (slow sweep speed) duty cycle < 98% and average over on/off periods with duty factor
<input type="checkbox"/> Refer as FCC KDB 558074, clause 10.5 Method AVGPSD-1 Alt (spectral trace averaging).
<input type="checkbox"/> Refer as FCC KDB 558074, clause 10.6 Method AVGPSD-2 Alt. (slow sweep speed)
<ul style="list-style-type: none"> ▪ For conducted measurement.
<ul style="list-style-type: none"> ▪ If The EUT supports multiple transmit chains using options given below: <ul style="list-style-type: none"> <input checked="" type="checkbox"/> Option 1: Measure and sum the spectra across the outputs. Refer as FCC KDB 662911, In-band power spectral density (PSD). Sample all transmit ports simultaneously using a spectrum analyzer for each transmit port. Where the trace bin-by-bin of each transmit port summing can be performed. (i.e., in the first spectral bin of output 1 is summed with that in the first spectral bin of output 2 and that from the first spectral bin of output 3, and so on up to the NTX output to obtain the value for the first frequency bin of the summed spectrum.). Add up the amplitude (power) values for the different transmit chains and use this as the new data trace. <input type="checkbox"/> Option 2: Measure and sum spectral maxima across the outputs. With this technique, spectra are measured at each output of the device at the required resolution bandwidth. The maximum value (peak) of each spectrum is determined. These maximum values are then summed mathematically in linear power units across the outputs. These operations shall be performed separately over frequency spans that have different out-of-band or spurious emission limits, <input type="checkbox"/> Option 3: Measure and add 10 log(N) dB, where N is the number of transmit chains. Refer as FCC KDB 662911, In-band power spectral density (PSD). Performed at each transmit chains and each transmit chains shall be compared with the limit have been reduced with 10 log(N). Or each transmit chains shall be add 10 log(N) to compared with the limit.

3.4.4 Test Setup

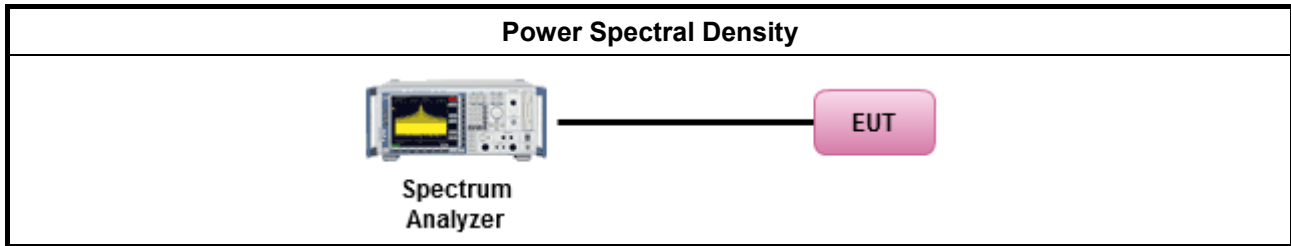

3.4.5 Test Result of Power Spectral Density

Refer as Appendix D

3.5 Emissions in Non-restricted Frequency Bands

3.5.1 Emissions in Non-restricted Frequency Bands Limit

Un-restricted Band Emissions Limit	
RF output power procedure	Limit (dB)
Peak output power procedure	20
Average output power procedure	30

Note 1: If the peak output power procedure is used to measure the fundamental emission power to demonstrate compliance to requirements, then the peak conducted output power measured within any 100 kHz outside the authorized frequency band shall be attenuated by at least 20 dB relative to the maximum measured in-band peak PSD level.

Note 2: If the average output power procedure is used to measure the fundamental emission power to demonstrate compliance to requirements, then the power in any 100 kHz outside of the authorized frequency band shall be attenuated by at least 30 dB relative to the maximum measured in-band average PSD level.

3.5.2 Measuring Instruments

Refer a test equipment and calibration data table in this test report.

3.5.3 Test Procedures

Test Method
<ul style="list-style-type: none"> Refer as FCC KDB 558074, clause 11 for unwanted emissions into non-restricted bands.

3.5.4 Test Setup

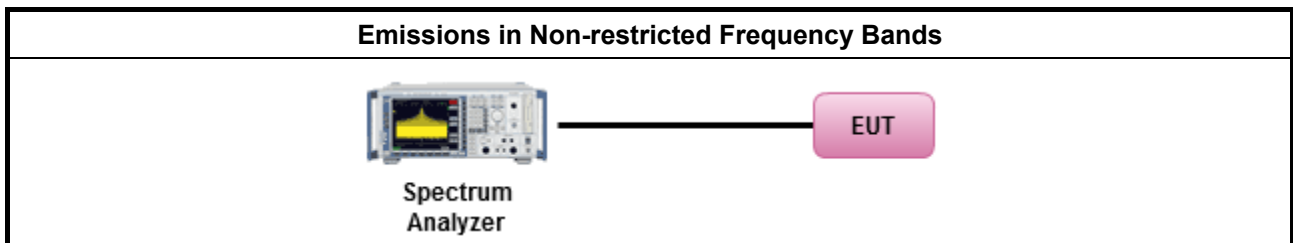

3.5.5 Test Result of Emissions in Non-restricted Frequency Bands

Refer as Appendix E

3.6 Emissions in Restricted Frequency Bands

3.6.1 Emissions in Restricted Frequency Bands Limit

Restricted Band Emissions Limit			
Frequency Range (MHz)	Field Strength (uV/m)	Field Strength (dBuV/m)	Measure Distance (m)
0.009~0.490	2400/F(kHz)	48.5 - 13.8	300
0.490~1.705	24000/F(kHz)	33.8 - 23	30
1.705~30.0	30	29	30
30~88	100	40	3
88~216	150	43.5	3
216~960	200	46	3
Above 960	500	54	3

Note 1: Test distance for frequencies at or above 30 MHz, measurements may be performed at a distance other than the limit distance provided they are not performed in the near field and the emissions to be measured can be detected by the measurement equipment. When performing measurements at a distance other than that specified, the results shall be extrapolated to the specified distance using an extrapolation factor of 20 dB/decade (inverse of linear distance for field-strength measurements, inverse of linear distance-squared for power-density measurements).

Note 2: Test distance for frequencies at below 30 MHz, measurements may be performed at a distance closer than the EUT limit distance; however, an attempt should be made to avoid making measurements in the near field. When performing measurements below 30 MHz at a closer distance than the limit distance, the results shall be extrapolated to the specified distance by either making measurements at a minimum of two or more distances on at least one radial to determine the proper extrapolation factor or by using the square of an inverse linear distance extrapolation factor (40 dB/decade). The test report shall specify the extrapolation method used to determine compliance of the EUT.

3.6.2 Measuring Instruments

Refer a test equipment and calibration data table in this test report.

3.6.3 Test Procedures

Test Method	
<ul style="list-style-type: none"> ▪ The average emission levels shall be measured in [duty cycle \geq 98 or duty factor]. 	
<ul style="list-style-type: none"> ▪ Refer as ANSI C63.10, clause 6.9.2.2 band-edge testing shall be performed at the lowest frequency channel and highest frequency channel within the allowed operating band. 	
<ul style="list-style-type: none"> ▪ For the transmitter unwanted emissions shall be measured using following options below: 	
	<ul style="list-style-type: none"> ▪ Refer as FCC KDB 558074, clause 12 for unwanted emissions into restricted bands.
	<input type="checkbox"/> Refer as FCC KDB 558074, clause 12.2.5.1 Option 1 (trace averaging for duty cycle \geq 98%)
	<input type="checkbox"/> Refer as FCC KDB 558074, clause 12.2.5.2 Option 2 (trace averaging + duty factor).
	<input checked="" type="checkbox"/> Refer as FCC KDB 558074, clause 12.2.5.3 Option 3 (Reduced VBW \geq 1/T).
	<input type="checkbox"/> Refer as ANSI C63.10, clause 4.2.3.2.3 (Reduced VBW). VBW \geq 1/T, where T is pulse time.
	<input type="checkbox"/> Refer as ANSI C63.10, clause 4.2.3.2.4 average value of pulsed emissions.
	<input checked="" type="checkbox"/> Refer as FCC KDB 558074, clause 12.2.4 measurement procedure peak limit.
<ul style="list-style-type: none"> ▪ For the transmitter band-edge emissions shall be measured using following options below: 	
	<ul style="list-style-type: none"> ▪ Refer as FCC KDB 558074 clause 13.1, When the performing peak or average radiated measurements, emissions within 2 MHz of the authorized band edge may be measured using the marker-delta method described below.
	<ul style="list-style-type: none"> ▪ Refer as FCC KDB 558074, clause 13.2 (ANSI C63.10, clause 6.9.3) for marker-delta method for band-edge measurements.
	<ul style="list-style-type: none"> ▪ Refer as FCC KDB 558074, clause 13.3 for narrower resolution bandwidth (100kHz) using the band power and summing the spectral levels (i.e., 1 MHz).
<ul style="list-style-type: none"> ▪ For conducted and cabinet radiation measurement, refer as FCC KDB 558074, clause 12.2.2. 	
	<ul style="list-style-type: none"> ▪ For conducted unwanted emissions into restricted bands (absolute emission limits). Devices with multiple transmit chains using options given below: (1) Measure and sum the spectra across the outputs or (2) Measure and add 10 log(N) dB
	<ul style="list-style-type: none"> ▪ For FCC KDB 662911 The methodology described here may overestimate array gain, thereby resulting in apparent failures to satisfy the out-of-band limits even if the device is actually compliant. In such cases, compliance may be demonstrated by performing radiated tests around the frequencies at which the apparent failures occurred.

3.6.4 Test Setup

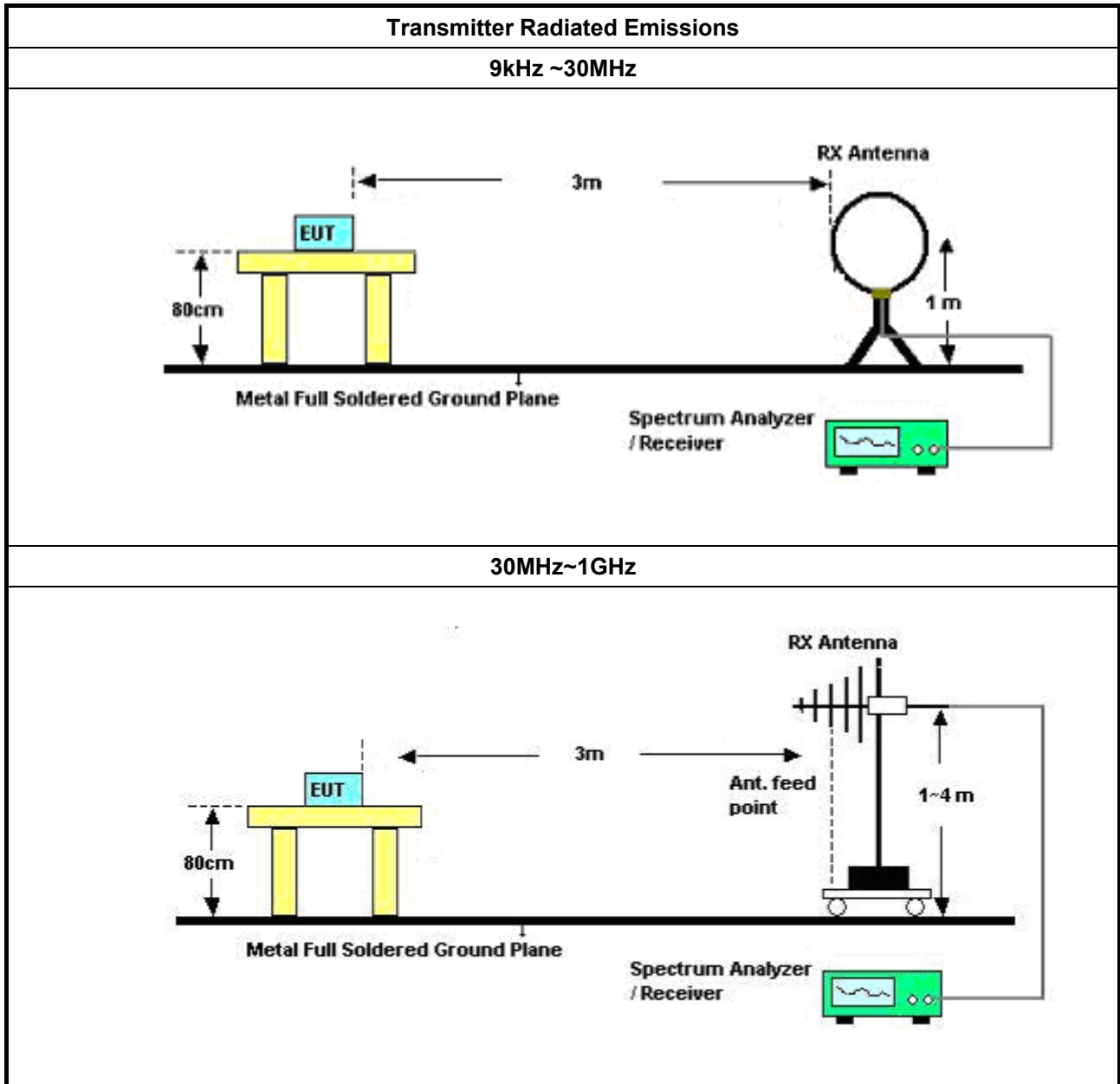

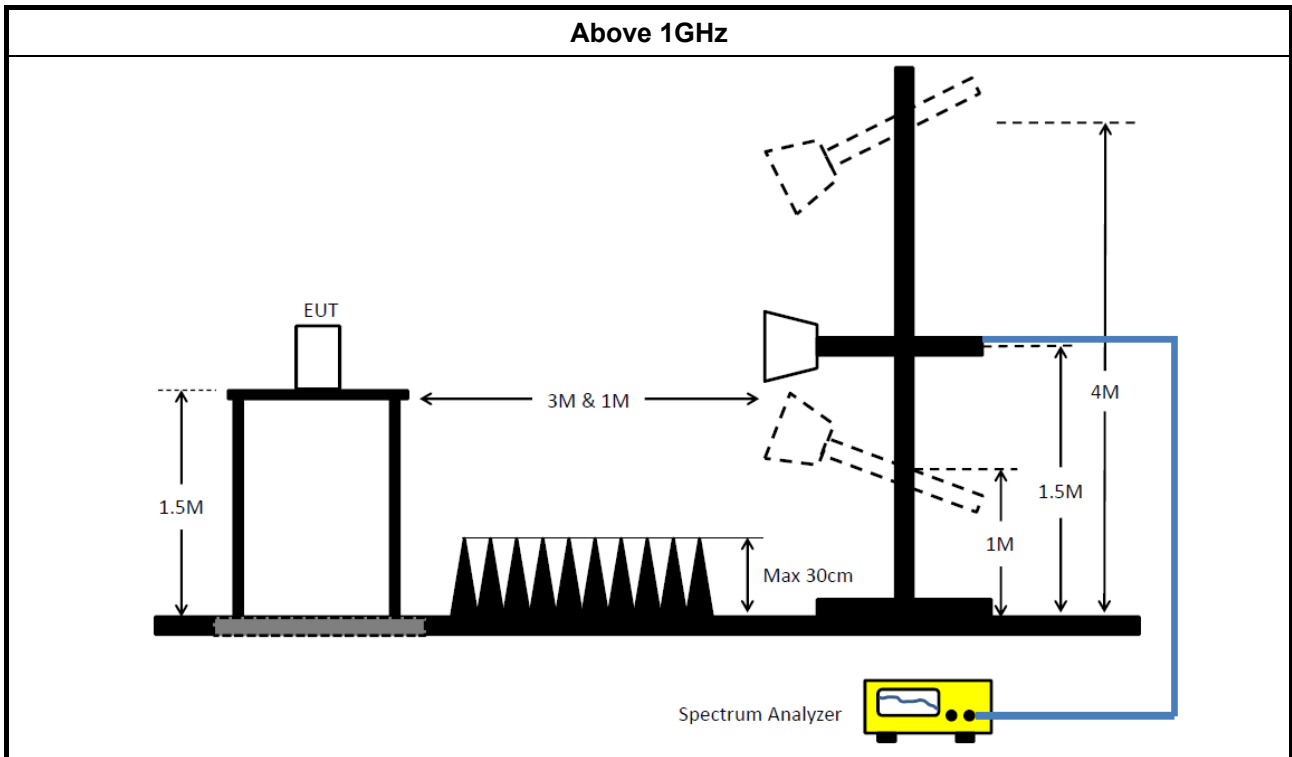

3.6.5 Transmitter Radiated Unwanted Emissions (Below 30MHz)

All amplitude of spurious emissions that are attenuated by more than 20 dB below the permissible value has no need to be reported.

3.6.6 Test Result of Transmitter Radiated Unwanted Emissions

Refer as Appendix F



4 Test Equipment and Calibration Data

Instrument	Manufacturer	Model No.	Serial No.	Characteristics	Calibration Date	Remark
EMI Receiver	Agilent	N9038A	My52260123	9kHz ~ 8.45GHz	Jan. 27, 2016	Conduction (CO01-CB)
LISN	F.C.C.	FCC-LISN-50-16-2	04083	150kHz ~ 100MHz	Dec. 08, 2015	Conduction (CO01-CB)
LISN	Schwarzbeck	NSLK 8127	8127647	9kHz ~ 30MHz	Dec. 23, 2015	Conduction (CO01-CB)
COND Cable	Woken	Cable	01	150kHz ~ 30MHz	May 24, 2016	Conduction (CO01-CB)
Software	Audix	E3	6.120210n	-	N.C.R.	Conduction (CO01-CB)
BILOG ANTENNA with 6dB Attenuator	TESEQ & EMCI	CBL6112D & N-6-06	37880 & AT-N0609	20MHz ~ 2GHz	Aug. 30, 2016	Radiation (03CH01-CB)
Horn Antenna	EMCO	3115	00075790	750MHz ~ 18GHz	Nov. 10, 2016	Radiation (03CH01-CB)
Horn Antenna	Schwarzbeck	BBHA 9170	BBHA9170252	15GHz ~ 40GHz	Jul. 25, 2016	Radiation (03CH01-CB)
Pre-Amplifier	Agilent	8447D	2944A10991	0.1MHz ~ 1.3GHz	Mar. 15, 2016	Radiation (03CH01-CB)
Pre-Amplifier	Agilent	8449B	3008A02310	1GHz ~ 26.5GHz	Jan. 18, 2016	Radiation (03CH01-CB)
Pre-Amplifier	MITEQ	TTA1840-35-HG	1864479	18GHz ~ 40GHz	Jun. 28, 2016	Radiation (03CH01-CB)
Spectrum Analyzer	R&S	FSP40	100056	9kHz ~ 40GHz	Nov. 21, 2016	Radiation (03CH01-CB)
EMI Test	R&S	ESCS	100355	9kHz ~ 2.75GHz	May 16, 2016	Radiation (03CH01-CB)
RF Cable-low	Woken	Low Cable-1	N/A	30 MHz ~ 1 GHz	Oct. 24, 2016	Radiation (03CH01-CB)
RF Cable-high	Woken	High Cable-16	N/A	1 GHz ~ 18 GHz	Oct. 24, 2016	Radiation (03CH01-CB)
RF Cable-high	Woken	High Cable-17	N/A	1 GHz ~ 18 GHz	Oct. 24, 2016	Radiation (03CH01-CB)
RF Cable-high	Woken	High Cable-40G-1	N/A	18GHz ~ 40 GHz	Oct. 24, 2016	Radiation (03CH01-CB)
RF Cable-high	Woken	High Cable-40G-2	N/A	18GHz ~ 40 GHz	Oct. 24, 2016	Radiation (03CH01-CB)
Test Software	Audix	E3	6.2009-I0-7	N/A	N/A	Radiation (03CH01-CB)
Spectrum analyzer	R&S	FSV40	100979	9kHz~40GHz	Dec. 09, 2015	Conducted (TH01-CB)



Instrument	Manufacturer	Model No.	Serial No.	Characteristics	Calibration Date	Remark
RF Cable-high	Woken	RG402	High Cable-6	1 GHz – 26.5 GHz	Oct. 24, 2016	Conducted (TH01-CB)
RF Cable-high	Woken	RG402	High Cable-7	1 GHz – 26.5 GHz	Oct. 24, 2016	Conducted (TH01-CB)
RF Cable-high	Woken	RG402	High Cable-8	1 GHz – 26.5 GHz	Oct. 24, 2016	Conducted (TH01-CB)
RF Cable-high	Woken	RG402	High Cable-9	1 GHz – 26.5 GHz	Oct. 24, 2016	Conducted (TH01-CB)
RF Cable-high	Woken	RG402	High Cable-10	1 GHz – 26.5 GHz	Oct. 24, 2016	Conducted (TH01-CB)
Cable	Marvelous Microwave	n/a	Cable-REF-1	9k-1GHz	Oct. 21, 2016	Conducted (TH01-CB)
Power Sensor	Agilent	U2021XA	MY54320014	50MHz~18GHz	Apr. 20, 2016	Conducted (TH01-CB)

Note: Calibration Interval of instruments listed above is one year.

N.C.R. means Non-Calibration required.

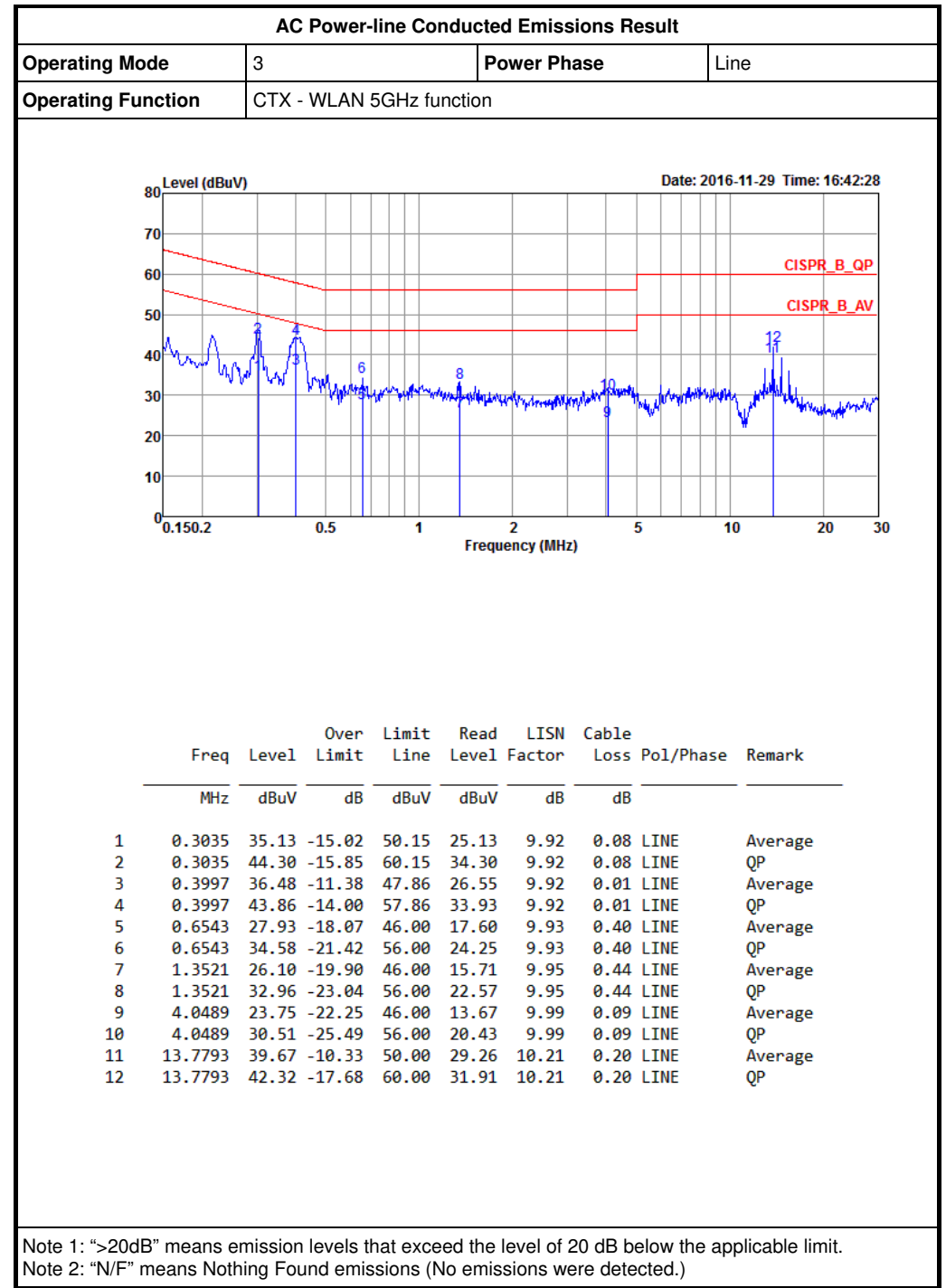
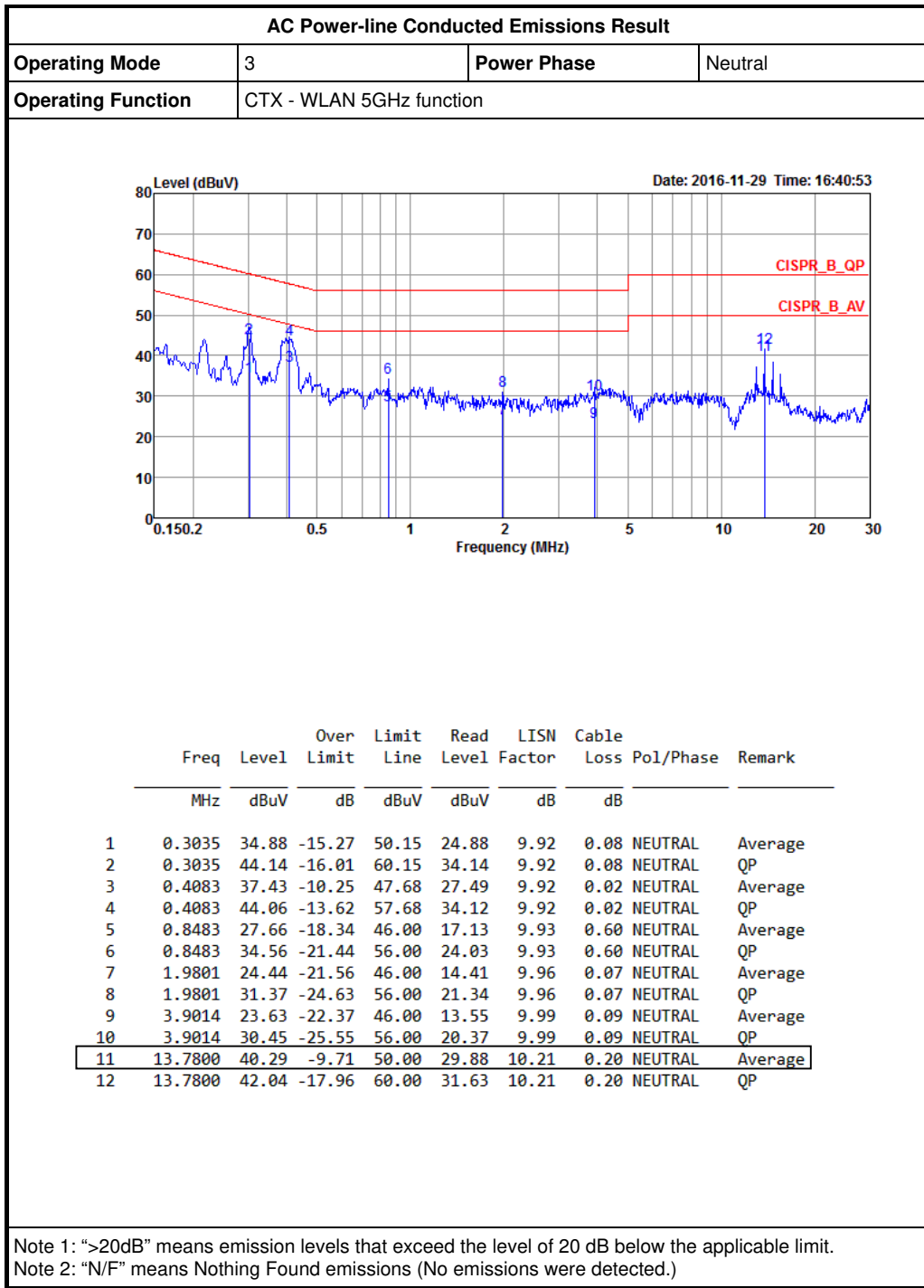



Summary

Mode	Max-N dB (Hz)	Max-OBW (Hz)	ITU-Code	Min-N dB (Hz)	Min-OBW (Hz)
2.4G;Zigbee;Nss1;Ntx1(2)	1.544M	2.349M	2M35G1D	1.481M	2.318M



Result

Mode	Result	Limit (Hz)	P2-N dB (Hz)	P2-OBW (Hz)
2.4G;Zigbee;Nss1;Ntx1(2);2425	Pass	500k	1.481M	2.349M
2.4G;Zigbee;Nss1;Ntx1(2);2450	Pass	500k	1.544M	2.318M
2.4G;Zigbee;Nss1;Ntx1(2);2475	Pass	500k	1.525M	2.318M

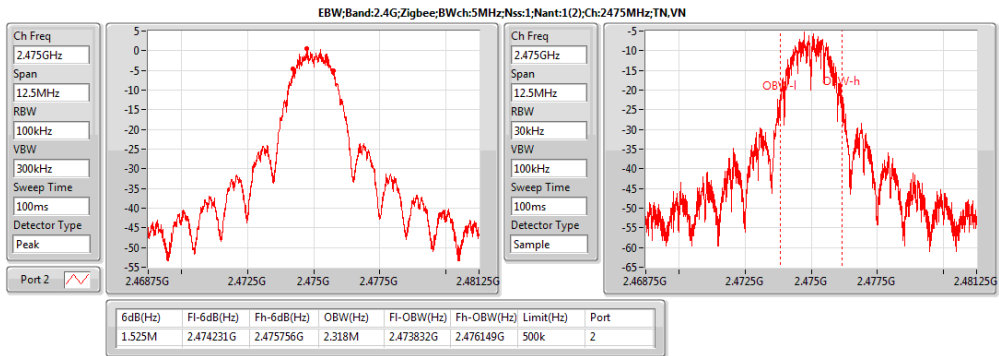
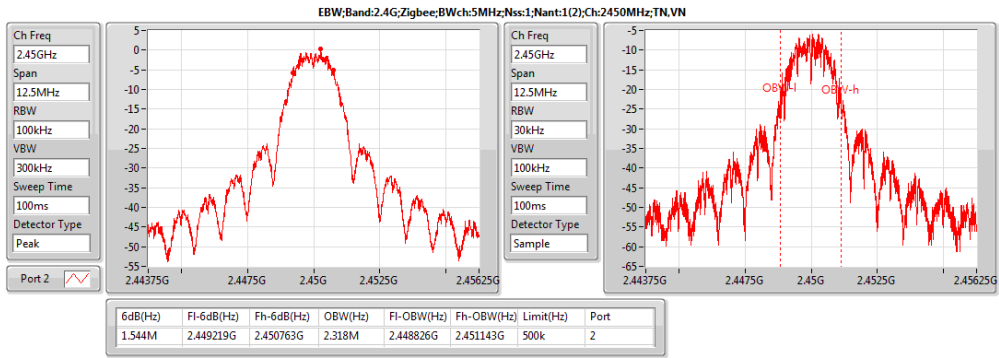
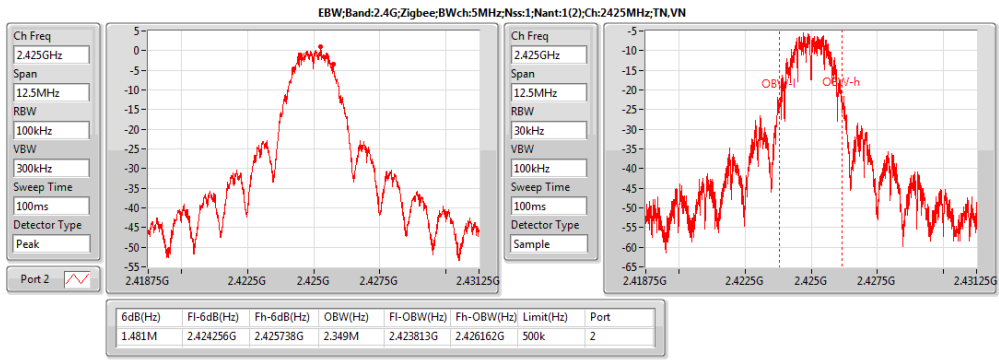



Summary

Mode	Sum (dBm)	Sum (W)	EIRP (dBm)	EIRP (W)
2.4G;Zigbee;Nss1;Ntx1(2)	6.00	0.00398	10.00	0.01



Result

Mode	Result	DG (dBi)	Sum (dBm)	Sum Lim. (dBm)	EIRP (dBm)	EIRP Lim. (dBm)	P2 (dBm)
2.4G;Zigbee;Nss1;Ntx1(2);2425	Pass	4.00	6.00	30.00	10.00	36.00	6.00
2.4G;Zigbee;Nss1;Ntx1(2);2450	Pass	4.00	5.01	30.00	9.01	36.00	5.01
2.4G;Zigbee;Nss1;Ntx1(2);2475	Pass	4.00	5.25	30.00	9.25	36.00	5.25



Summary

Mode	PD (dBm/RBW)	EIRP.PD (dBm/RBW)
2.4G;Zigbee;Nss1;Ntx1(2)	-11.86	-7.86



Result

Mode	Result	DG (dBi)	PD (dBm/RBW)	PD.Limit (dBm/RBW)	P2 (dBm/RBW)
2.4G;Zigbee;Nss1;Ntx1(2);2425	Pass	4.00	-11.86	8.00	-11.86
2.4G;Zigbee;Nss1;Ntx1(2);2450	Pass	4.00	-14.65	8.00	-14.65
2.4G;Zigbee;Nss1;Ntx1(2);2475	Pass	4.00	-13.92	8.00	-13.92

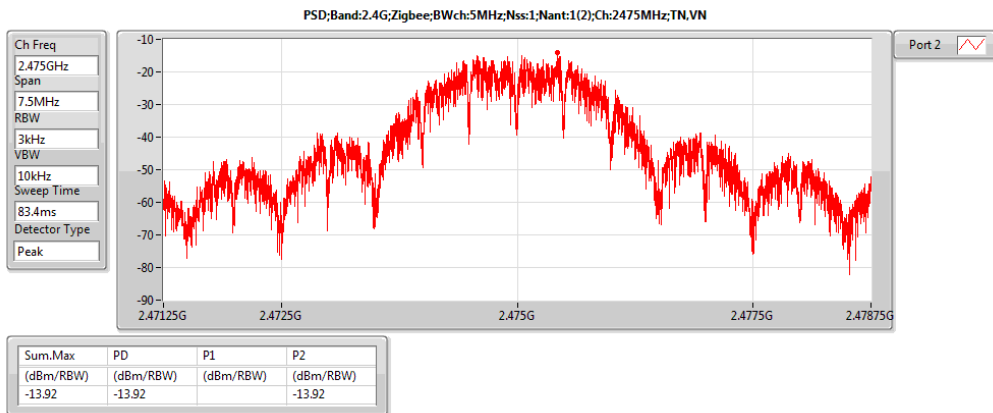
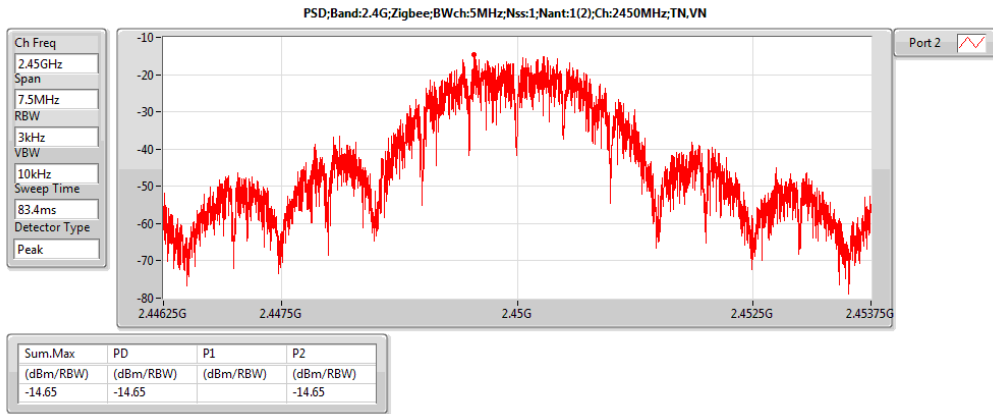
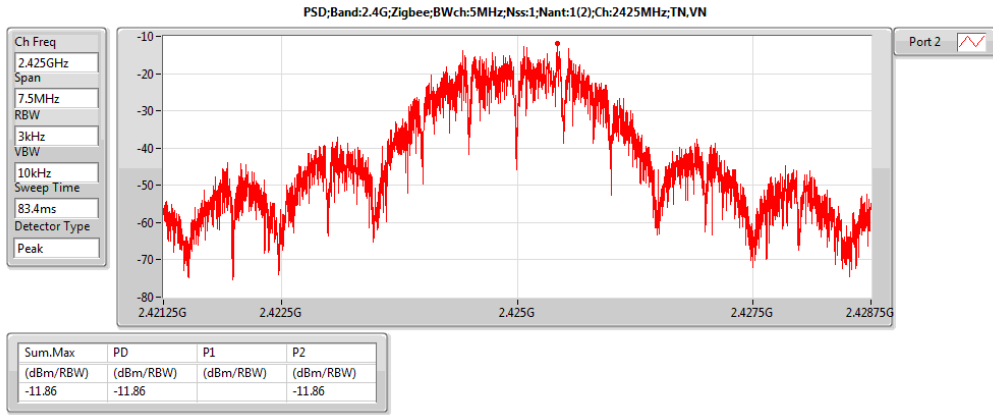



Summary

Mode	Result	Ref (Hz)	Ref (dBm)	Limit (dBm)	Freq (Hz)	Level (dBm)	Freq (Hz)	Level (dBm)	Freq (Hz)	Level (dBm)	Freq (Hz)	Level (dBm)	Port
2.4G;Zigbee;Nss1;Ntx1(2);2425	Pass	2.4501G	-0.79	-30.79	1.89676G	-54.62	2.39022G	-55.84	2.48526G	-54.88	16.641649G	-49.00	2



Result

Mode	Result	Ref (Hz)	Ref (dBm)	Limit (dBm)	Freq (Hz)	Level (dBm)	Freq (Hz)	Level (dBm)	Freq (Hz)	Level (dBm)	Freq (Hz)	Level (dBm)	Port
2.4G;Zigbee;Nss1;Ntx1(2);2425	Pass	2.4501G	-0.79	-30.79	1.89676G	-54.62	2.39022G	-55.84	2.48526G	-54.88	16.641649G	-49.00	2
2.4G;Zigbee;Nss1;Ntx1(2);2450	Pass	2.4501G	-0.79	-30.79	2.01594G	-55.57	2.39228G	-55.15	2.48768G	-55.51	6.96948G	-49.30	2
2.4G;Zigbee;Nss1;Ntx1(2);2475	Pass	2.4501G	-0.79	-30.79	1.94632G	-55.22	2.39926G	-54.94	2.4841G	-50.46	6.98636G	-49.87	2



CSEndB Result

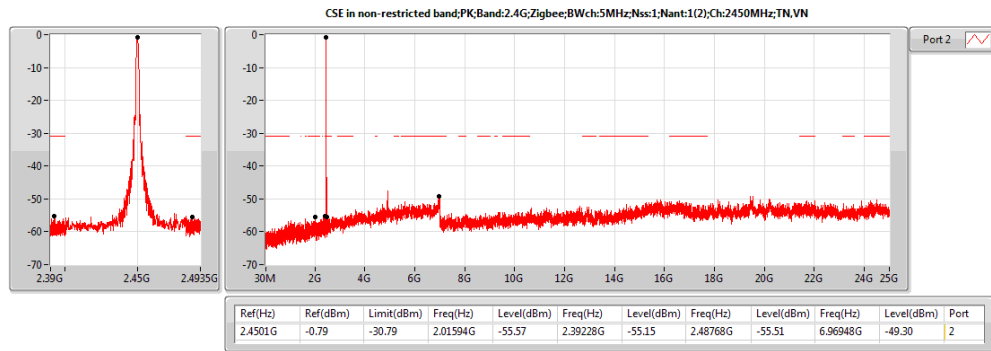
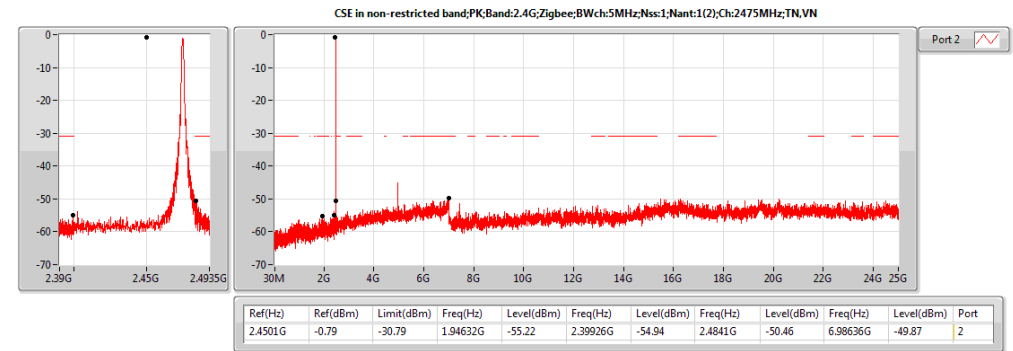
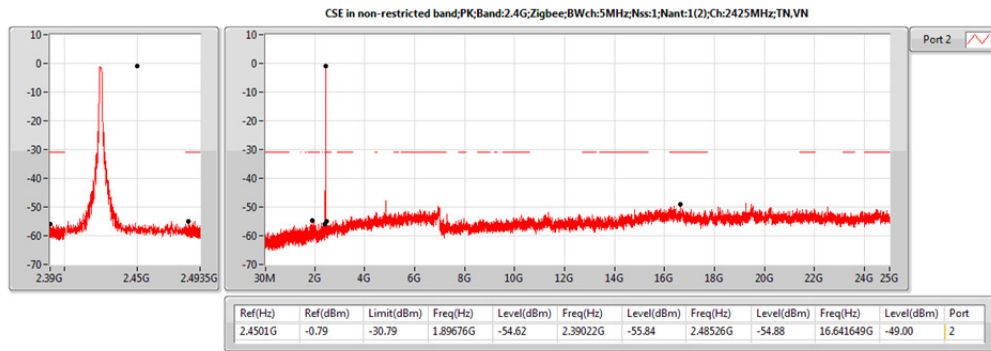

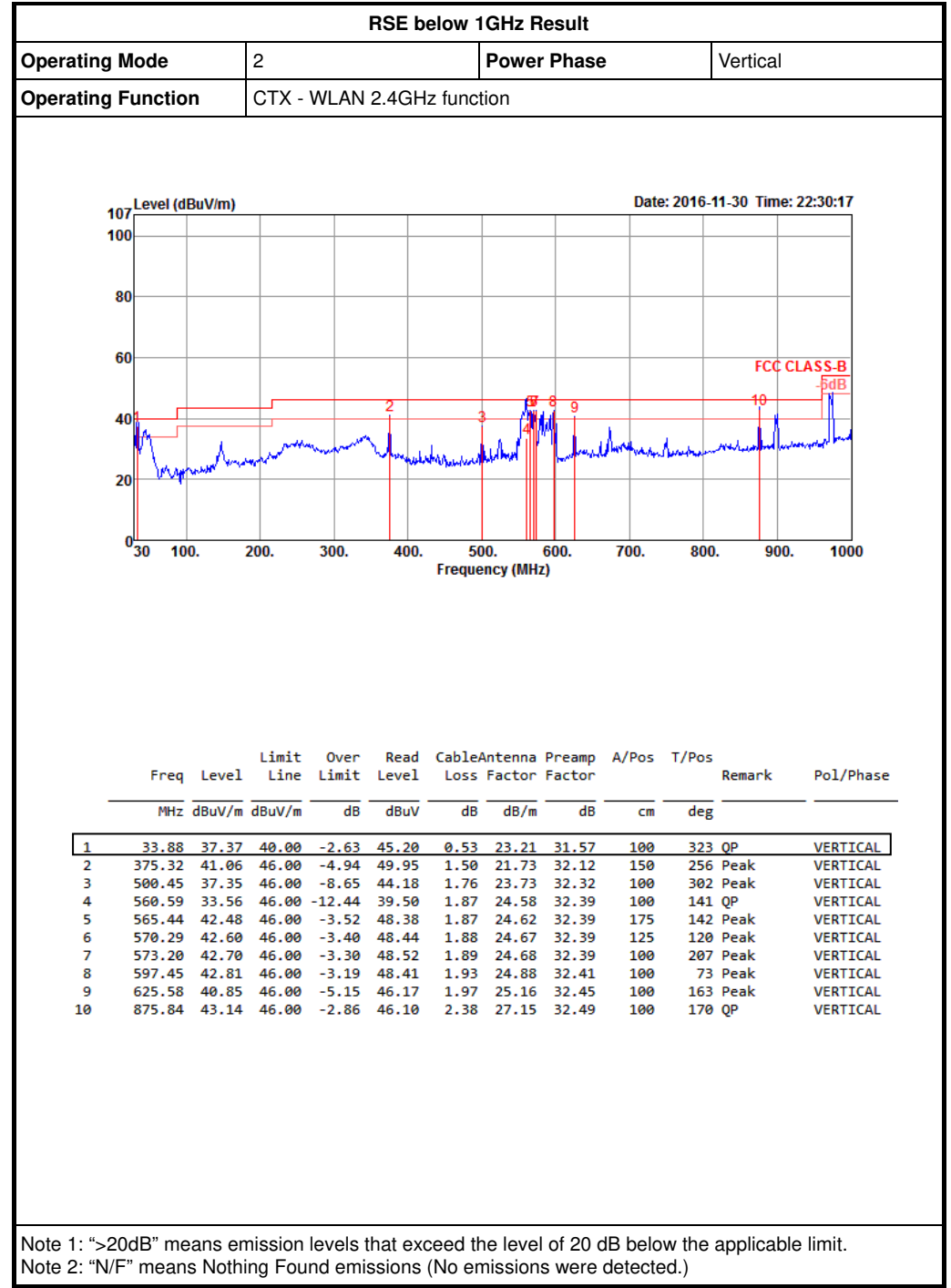
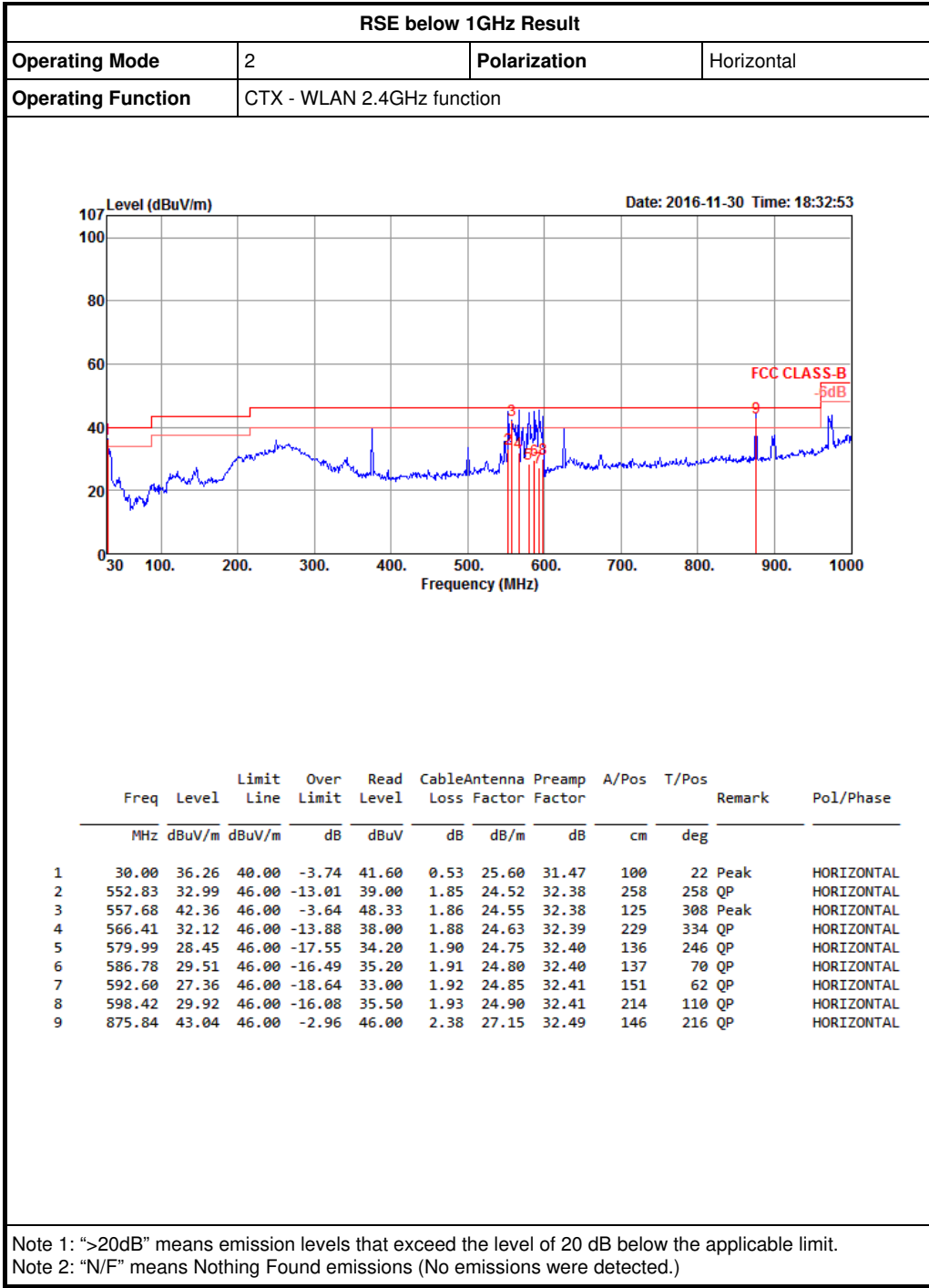



Summary

Mode	Result	Type	Freq (Hz)	Level (dBuV/m)	Limit (dBuV/m)	Margin (dB)	Factor (dB)	Dist (m)	Pol. (H/V)	Azimuth (°)	Height (m)	Comments
2.4G;Zigbee;Nss1;Ntx1;2425;TX	Pass	AV	2.484G	49.22	54.00	-4.78	32.25	3	V	26	2.76	-

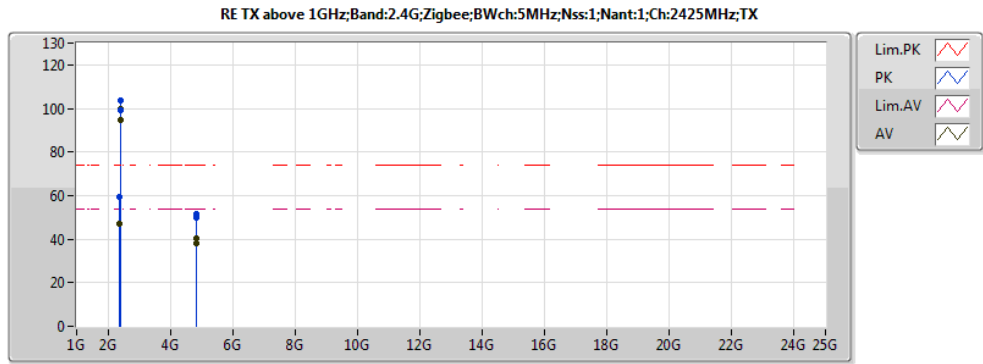

20161122
EUT Y 1TX_ANT2
Setting 7
06-S-6

Type	Freq(Hz)	Level(dBuV/m)	Limit(dBuV/m)	Margin(dB)	Factor(dB)	Dist(m)	Pol.(H/V)	Azimuth(*)	Height(m)	Comments
AV	2.3868G	46.89	54.00	-7.11	31.95	3	H	77	2.76	-
AV	2.425G	94.96	Inf	-Inf	32.08	3	H	77	2.76	-
PK	2.3874G	59.30	74.00	-14.70	31.95	3	H	77	2.76	-
PK	2.4256G	99.39	Inf	-Inf	32.08	3	H	77	2.76	-
AV	2.3882G	46.93	54.00	-7.07	31.96	3	V	13	2.47	-
AV	2.425G	99.47	Inf	-Inf	32.08	3	V	13	2.47	-
PK	2.3796G	59.27	74.00	-14.73	31.92	3	V	13	2.47	-
PK	2.4254G	103.74	Inf	-Inf	32.08	3	V	13	2.47	-
AV	4.84902G	40.11	54.00	-13.89	7.27	3	H	102	1.86	-
PK	4.84894G	51.56	74.00	-22.44	7.27	3	H	102	1.86	-
AV	4.84898G	38.06	54.00	-15.94	7.27	3	V	47	1.50	-
PK	4.84884G	50.04	74.00	-23.96	7.27	3	V	47	1.50	-



20161122
EUT Y 1TX_ANT2
Setting 7
06-S-6

Type	Freq(Hz)	Level(dBuV/m)	Limit(dBuV/m)	Margin(dB)	Factor(dB)	Dist(m)	Pol.(H/V)	Azimuth(*)	Height(m)	Comments
AV	4.84898G	38.06	54.00	-15.94	7.27	3	V	47	1.50	-
PK	4.84884G	50.04	74.00	-23.96	7.27	3	V	47	1.50	-

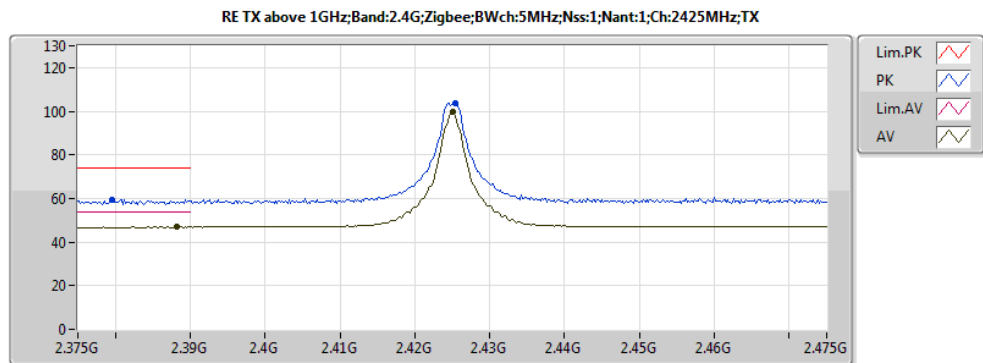

20161122
EUT Y 1TX_ANT2
Setting 7
06-S-6

Type	Freq(Hz)	Level(dBuV/m)	Limit(dBuV/m)	Margin(dB)	Factor(dB)	Dist(m)	Pol.(H/V)	Azimuth(*)	Height(m)	Comments
AV	2.3882G	46.93	54.00	-7.07	31.96	3	V	13	2.47	-
AV	2.425G	99.47	Inf	-Inf	32.08	3	V	13	2.47	-
PK	2.3796G	59.27	74.00	-14.73	31.92	3	V	13	2.47	-
PK	2.4254G	103.74	Inf	-Inf	32.08	3	V	13	2.47	-

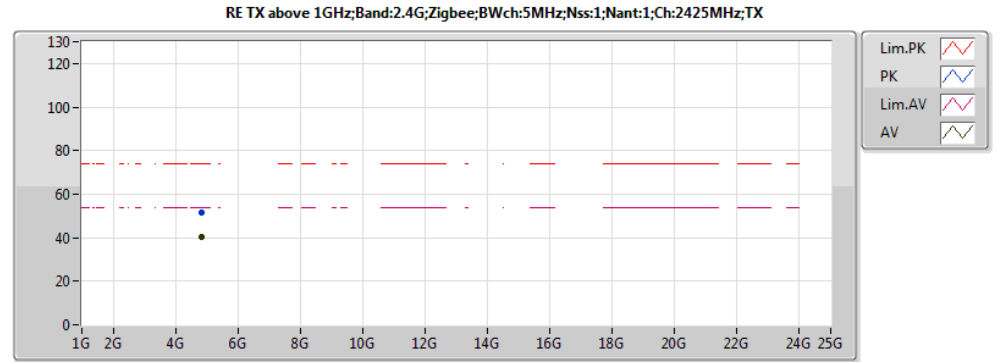

20161122
EUT Y 1TX_ANT2
Setting 7
06-S-6

Type	Freq(Hz)	Level(dBuV/m)	Limit(dBuV/m)	Margin(dB)	Factor(dB)	Dist(m)	Pol.(H/V)	Azimuth(*)	Height(m)	Comments
AV	4.84902G	40.11	54.00	-13.89	7.27	3	H	102	1.86	-
PK	4.84894G	51.56	74.00	-22.44	7.27	3	H	102	1.86	-

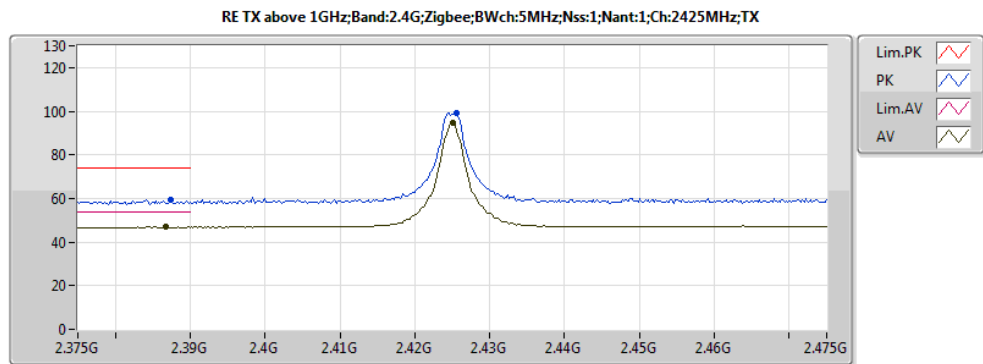

20161122
EUT Y 1TX_ANT2
Setting 7
06-S-6

Type	Freq(Hz)	Level(dBuV/m)	Limit(dBuV/m)	Margin(dB)	Factor(dB)	Dist(m)	Pol.(H/V)	Azimuth(*)	Height(m)	Comments
AV	2.3868G	46.89	54.00	-7.11	31.95	3	H	77	2.76	-
AV	2.425G	94.96	Inf	-Inf	32.08	3	H	77	2.76	-
PK	2.3874G	59.30	74.00	-14.70	31.95	3	H	77	2.76	-
PK	2.4256G	99.39	Inf	-Inf	32.08	3	H	77	2.76	-

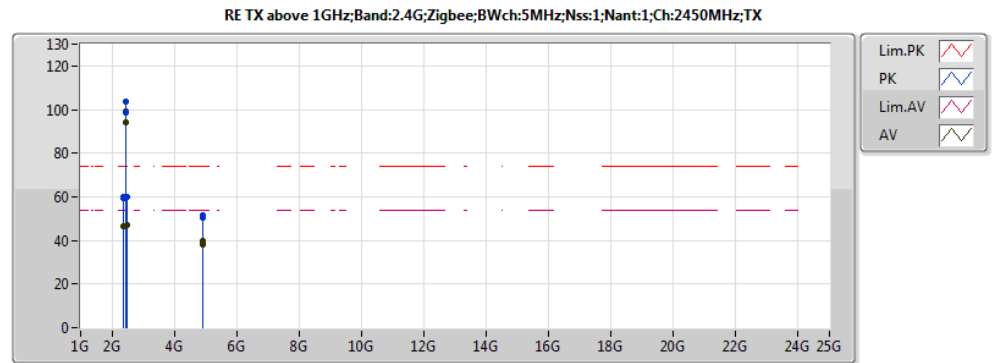

20161122
EUT Y 1TX_ANT2
Setting 7
06-S-6

Type	Freq(Hz)	Level(dBuV/m)	Limit(dBuV/m)	Margin(dB)	Factor(dB)	Dist(m)	Pol.(H/V)	Azimuth(*)	Height(m)	Comments
AV	2.3884G	46.78	54.00	-7.22	31.96	3	H	96	1.78	-
AV	2.45G	94.39	Inf	-Inf	32.15	3	H	96	1.78	-
AV	2.5G	47.28	54.00	-6.72	32.30	3	H	96	1.78	-
PK	2.3808G	59.21	74.00	-14.79	31.93	3	H	96	1.78	-
PK	2.4496G	98.82	Inf	-Inf	32.15	3	H	96	1.78	-
PK	2.4944G	59.97	74.00	-14.03	32.28	3	H	96	1.78	-
AV	2.3884G	46.72	54.00	-7.28	31.96	3	V	7	2.78	-
AV	2.45G	99.21	Inf	-Inf	32.15	3	V	7	2.78	-
AV	2.4988G	47.34	54.00	-6.66	32.30	3	V	7	2.78	-
PK	2.368G	59.85	74.00	-14.15	31.88	3	V	7	2.78	-
PK	2.4496G	103.64	Inf	-Inf	32.15	3	V	7	2.78	-
PK	2.496G	59.97	74.00	-14.03	32.29	3	V	7	2.78	-
AV	4.90096G	39.89	54.00	-14.11	7.42	3	H	104	1.58	-
PK	4.90092G	51.48	74.00	-22.52	7.42	3	H	104	1.58	-
AV	4.89904G	38.12	54.00	-15.88	7.42	3	V	46	1.50	-
PK	4.89888G	50.23	74.00	-23.77	7.42	3	V	46	1.50	-

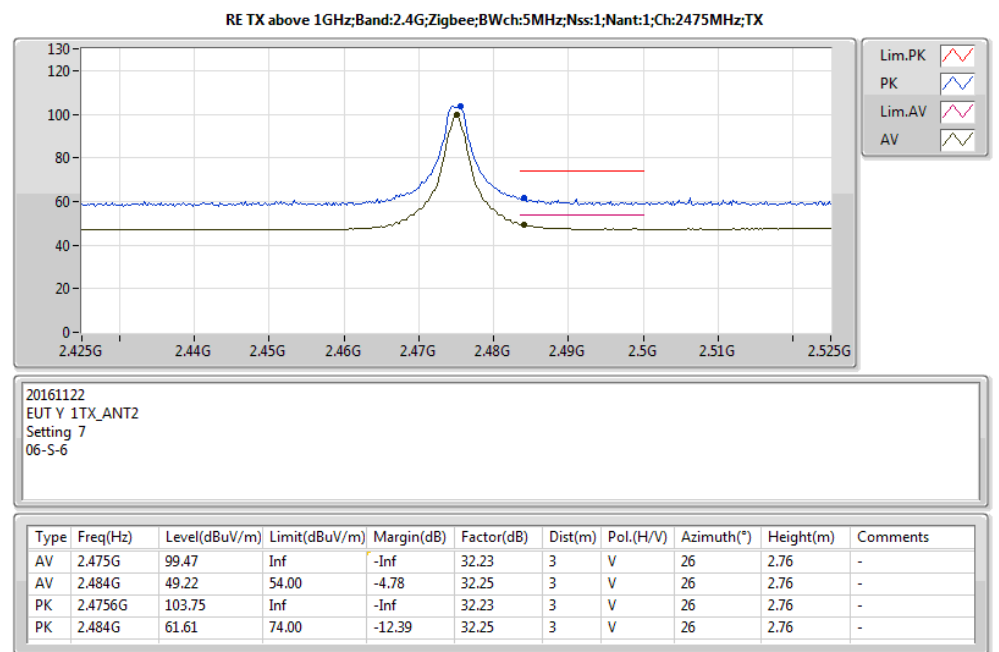
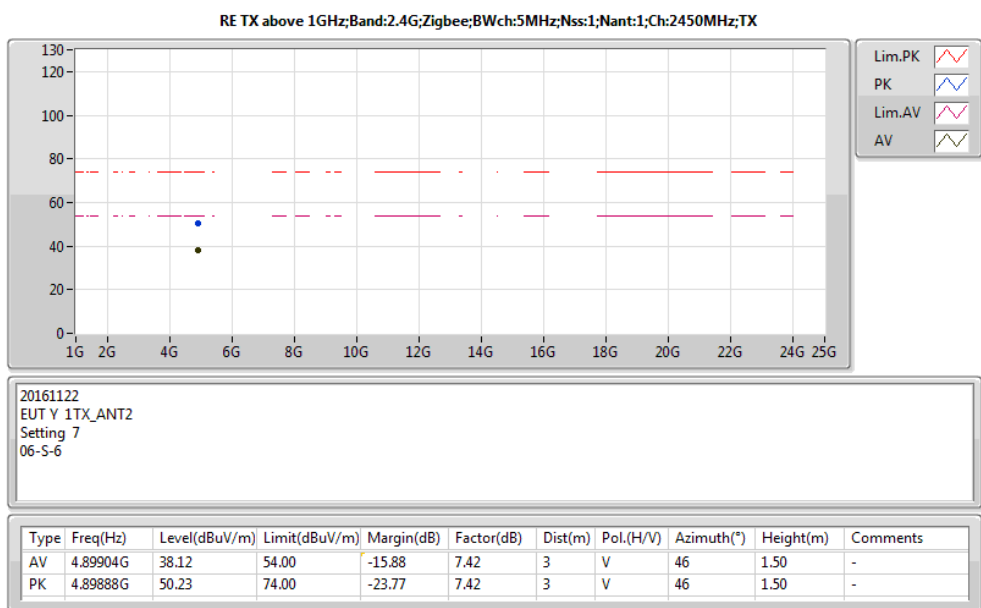
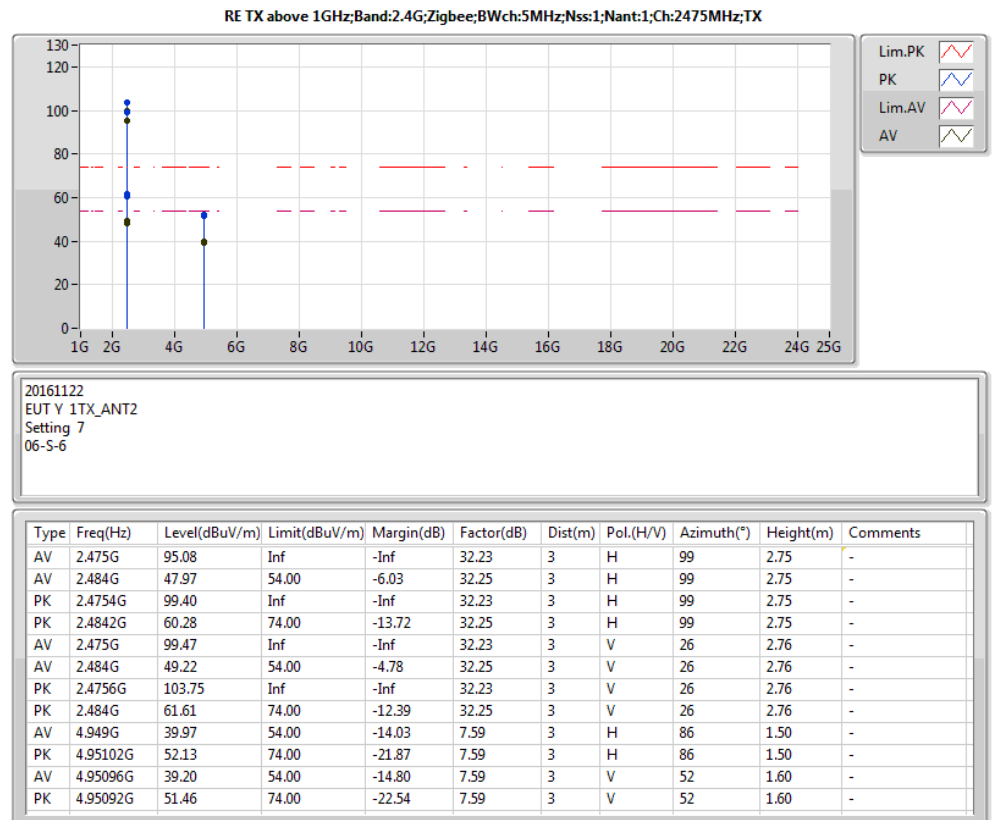
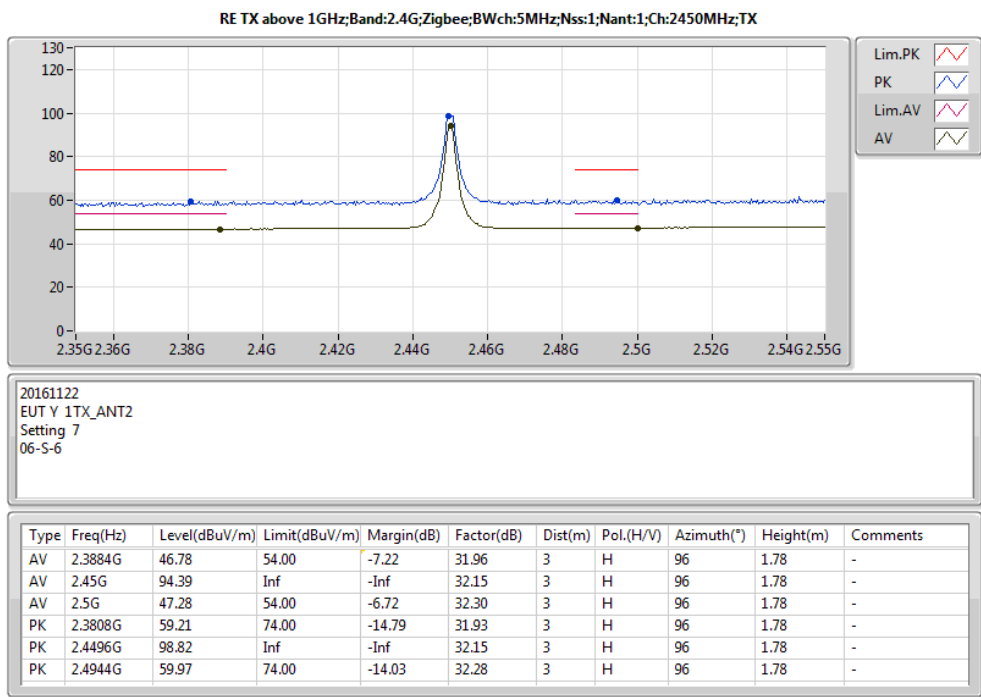
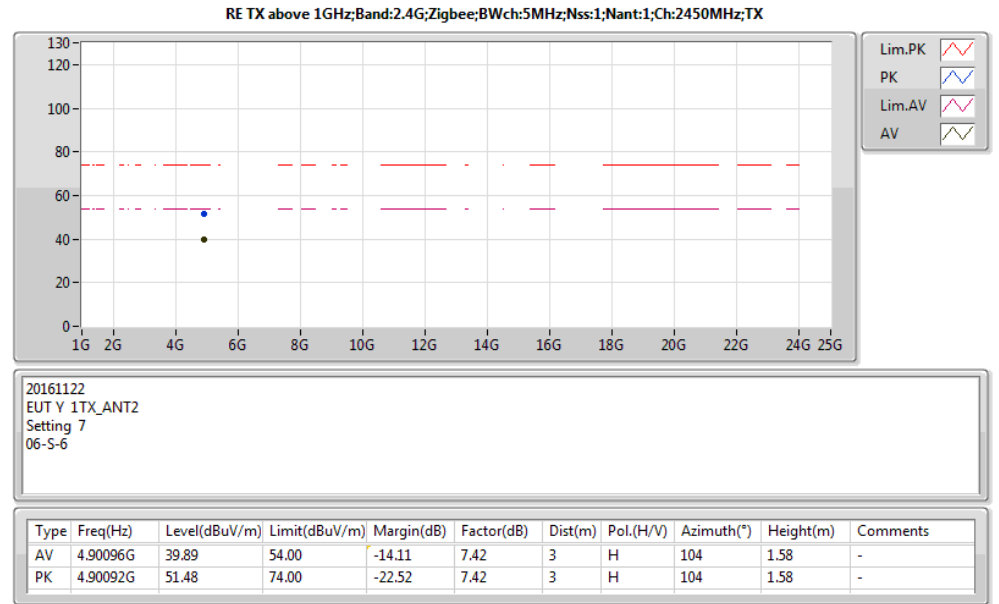
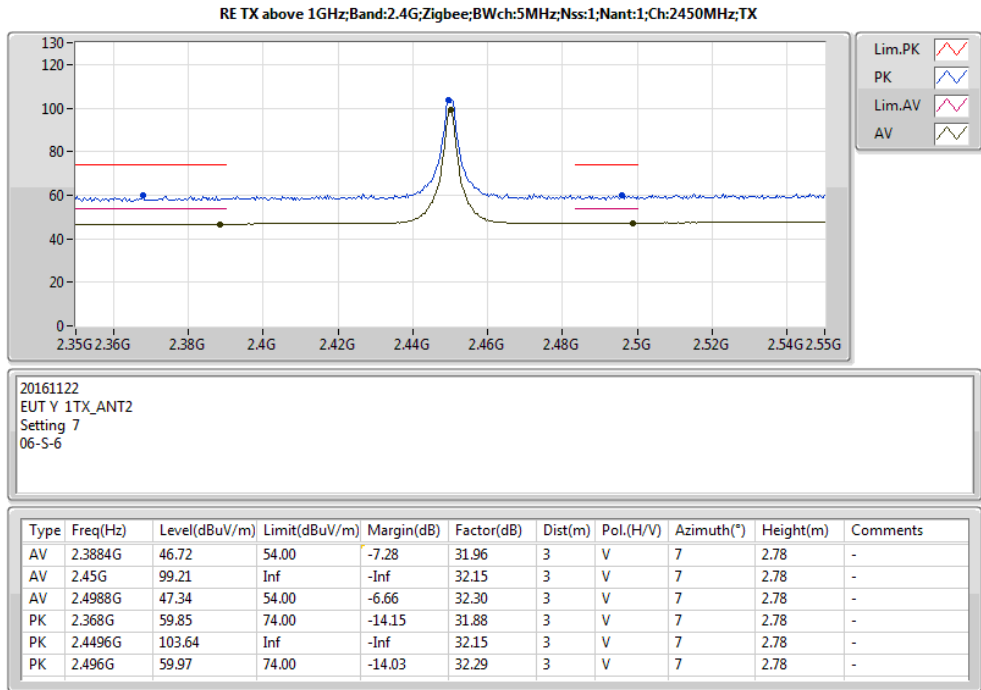

RE TX above 1GHz;Band:2.4G;Zigbee;BWch:5MHz;Nss:1;Nant:1;Ch:2475MHz;TX

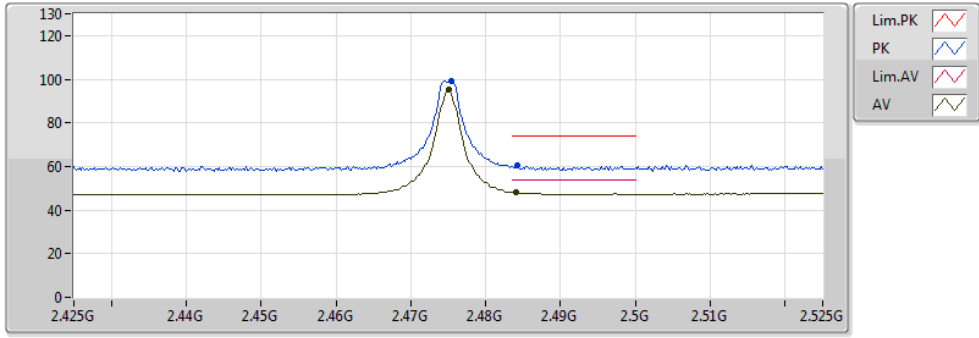

20161122
EUT Y 1TX_ANT2
Setting 7
06-S-6

Type	Freq(Hz)	Level(dBuV/m)	Limit(dBuV/m)	Margin(dB)	Factor(dB)	Dist(m)	Pol.(H/V)	Azimuth(°)	Height(m)	Comments
AV	2.475G	95.08	Inf	-Inf	32.23	3	H	99	2.75	-
AV	2.484G	47.97	54.00	-6.03	32.25	3	H	99	2.75	-
PK	2.4754G	99.40	Inf	-Inf	32.23	3	H	99	2.75	-
PK	2.4842G	60.28	74.00	-13.72	32.25	3	H	99	2.75	-

RE TX above 1GHz;Band:2.4G;Zigbee;BWch:5MHz;Nss:1;Nant:1;Ch:2475MHz;TX

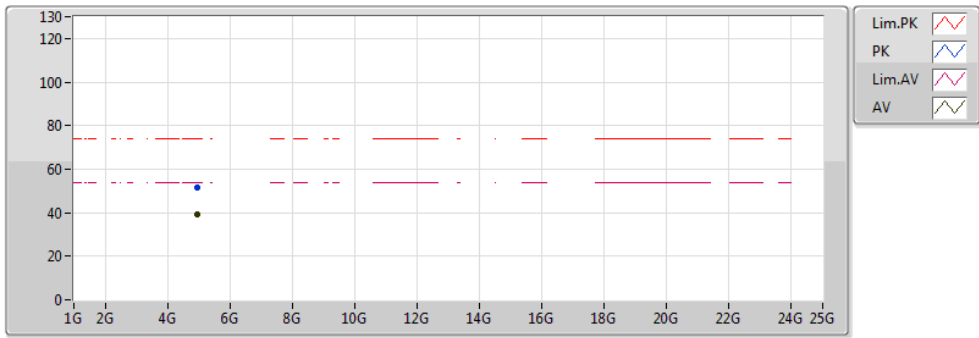

20161122
EUT Y 1TX_ANT2
Setting 7
06-S-6

Type	Freq(Hz)	Level(dBuV/m)	Limit(dBuV/m)	Margin(dB)	Factor(dB)	Dist(m)	Pol.(H/V)	Azimuth(°)	Height(m)	Comments
AV	4.95096G	39.20	54.00	-14.80	7.59	3	V	52	1.60	-
PK	4.95092G	51.46	74.00	-22.54	7.59	3	V	52	1.60	-

RE TX above 1GHz;Band:2.4G;Zigbee;BWch:5MHz;Nss:1;Nant:1;Ch:2475MHz;TX

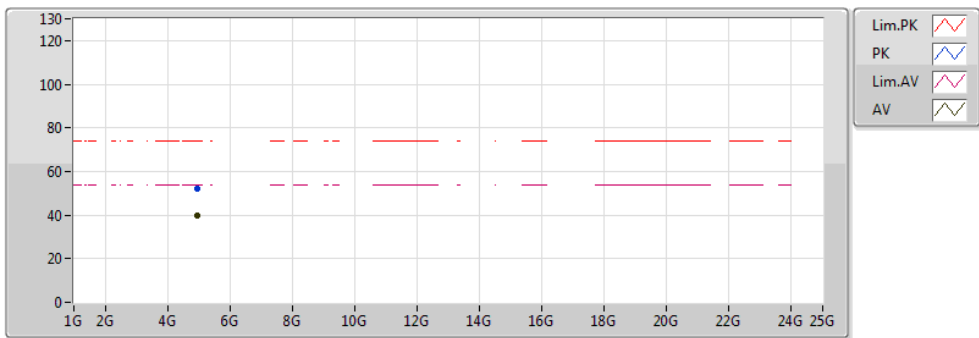

20161122
EUT Y 1TX_ANT2
Setting 7
06-S-6

Type	Freq(Hz)	Level(dBuV/m)	Limit(dBuV/m)	Margin(dB)	Factor(dB)	Dist(m)	Pol.(H/V)	Azimuth(°)	Height(m)	Comments
AV	4.949G	39.97	54.00	-14.03	7.59	3	H	86	1.50	-
PK	4.95102G	52.13	74.00	-21.87	7.59	3	H	86	1.50	-