

EWM322T/EWA322T – ANTENNA

2023-06-20 v6

## Model

EWM322T/EWA322T

## Manufacturer

Technicolor Connected Home USA LLC

4855 Peachtree Industrial Blvd. Suite 200 Norcross, Georgia 30092.

WLAN	2G	5G	6G
Chipset	BCM6715	BCM6715	BCM6715
MIMO	4x4	4x4	4x4
Interface	wl2	wl1	wl0
BW	20/40MHz	20/40/80/160MHz	20/40/80/160MHz
Frequencies (20MHz channels central frequencies)	2412MHz - 2462MHz	5180MHz - 5825MHz	5955MHz - 7115MHz

# 2G – 5G chipsets RF connectors

The Photo Please refer to Antenna Test Photo

# 6G chipset RF connectors

The Photo Please refer to Antenna Test Photo

# Antenna

Wi-Fi Antenna	Frequency band	IPN	Decription
DB1	2.4/5GHz	6322922A	ANTENNA PCB antenna Off-board DUAL BAND 2.4/5.0 GHZ W COAX CABLE 82MM BLUE MODULE DB1 EWA322TGFR2
DB2	2.4/5GHz	6322923A	ANTENNA PCB antenna Off-board DUAL BAND 2.4/5.0 GHZ W COAX CABLE 111MM GREY MODULE DB2 EWA322TGFR2
DB3	2.4/5GHz	6322924A	ANTENNA PCB antenna Off-board DUAL BAND 2.4/5.0 GHZ W COAX CABLE 145MM WHITE MODULE DB3 EWA322TGFR2
DB4	2.4/5GHz	6322925A	ANTENNA PCB antenna Off-board DUAL BAND 2.4/5.0 GHZ W COAX CABLE 129MM BLACK MODULE DB4 EWA322TGFR2
6G1	6GHz	6322927A	ANTENNA PCB antenna Off-board 6GHZ W COAX CABLE 68MM BLUE MODULE 6G1 EWA322TGFR2
6G2	6GHz	6322928A	ANTENNA PCB antenna Off-board 6GHZ W COAX CABLE 85MM WHITE MODULE 6G2 EWA322TGFR2
6G3	6GHz	6322929A	ANTENNA PCB antenna Off-board 6GHZ W COAX CABLE 70MM BLACK MODULE 6G3 EWA322TGFR2
6G4	6GHz	6322930A	ANTENNA PCB antenna Off-board 6GHZ W COAX CABLE 98MM GREY MODULE 6G4 EWA322TGFR2

- ▶ All antennas are fabricated by LUXSHARE-ICT (Address : No.158 Jinchang Road, Jinxi Town, Suzhou, Jiangsu province, China)

# Dual-band 2,4/5GHz antenna

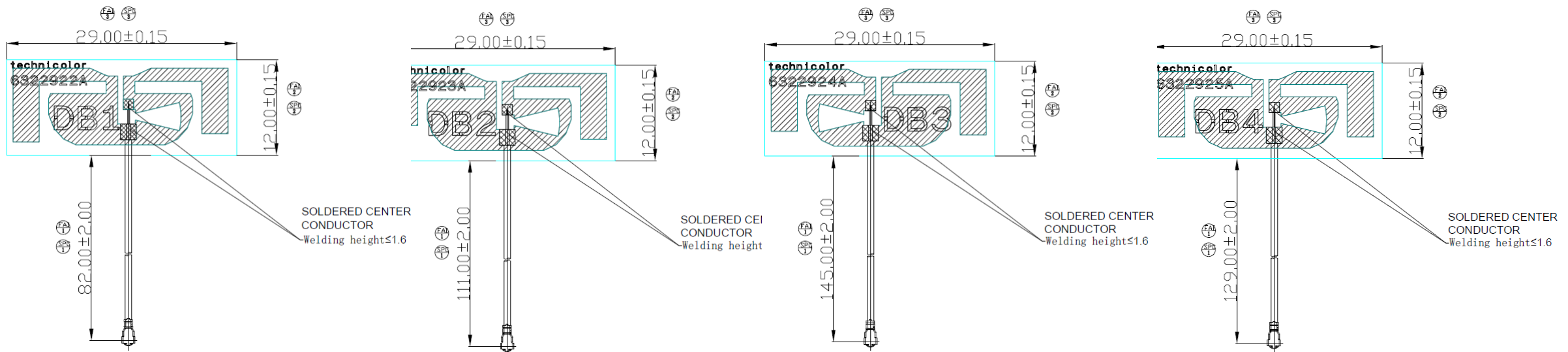

# 6GHz antenna

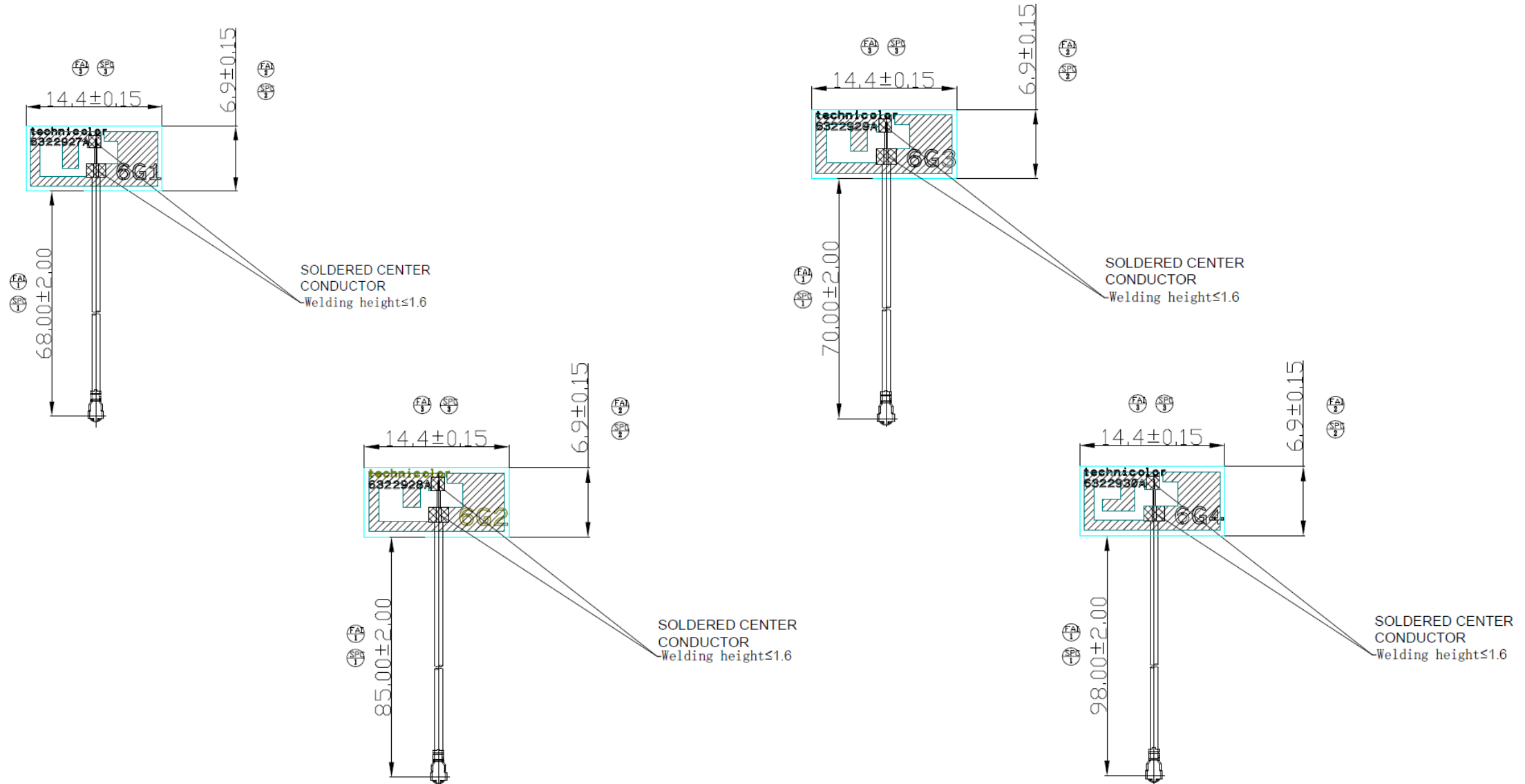

# Antenna test environment for the dual-band antennas

- The dual-band antennas are tested in a full anechoic chamber (MVG/SG24) with the VNA Keysight/ E5071C

The Photo Please refer to Antenna Test Photo

Satimo SG24	name of commercial test software
	spm1.3.1 and satenv 2.0.1.5 build12

Device	Type/Mode	Serial	Manufacturer	Cal. Date	Cal. due Date
SG24	Standard	SG24	MVG	11/15/2021	11/14/2022
Turn Table	N/A	-	MVG	N/A	N/A
Power Supply Unit	CASTLE 3K(6G)	190916-26590068	SANTAK	N/A	N/A
Active Switching Unit	N/A	MODU-009-A-0120	MVG	N/A	N/A
Control Unit SG24	N/A	MODU-022-A-0032	MVG	N/A	N/A
Amplification Unit	N/A	MODU-020-B-0005	MVG	N/A	N/A
Cable 8m - 400MHz to 6GHz	SUCOFLEX 106	SN 81469 /6	MVG	11/15/2021	11/14/2022
Temperature & Humidity	deli	-	deli	N/A	N/A
ENA Series Network Analyzer	E5071C	MY46523087	KeySight	11/24/2021	11/23/2022



# Antenna test environment for the 6GHz antennas

- The 6GHz antennas are tested in a full anechoic chamber (EMT-RCR120) with the VNA Keysight/ N5225B

The Photo Please refer to Antenna Test Photo

EMT-RCR120 Compact Antenna Test Range(CATR)	name of commercial test software
	EMT Far-Field Antenna Measurement System

Device	Type/Mode	Serial	Manufacturer	Cal.Date	Cal.Due Date
EMT-RCR120	Standard	EMT-RCR120	EM-Testing	10/26/2021	10/25/2022
Three-dimensional rotary table and its control system	Dongtintech	DT001201911104	EM-Testing	N/A	N/A
PNA Network Analyzer	N5225B	MY58422424	KeySight	6/23/2022	6/23/2023
Reflective surface system	RCR120	-	EM-Testing	N/A	N/A
Feeders and their control systems	EMT4000	-	EM-Testing	N/A	N/A
Power Supply Unit	CASTLE 3K(6G)	190929-35470033	SANTAK	N/A	N/A
Cable 4m - 5GHz to 50GHz	JB360	-	Jun You	10/26/2021	10/25/2022
Temperature & Humidity	deli	-	deli	N/A	N/A

# Antenna test setup

- Antennas are tested after a full calibration of the chamber (including the testing cable insertion loss)
- Antenna are tested in LUXSHARE-ICT (Address : No.158 Jinchang Road, Jinxi Town, Suzhou, Jiangsu province, China)
- Antennas are tested by Xucheng. Hu ([xucheng.hu@luxshare-ict.com](mailto:xucheng.hu@luxshare-ict.com))
- Antennas are tested in 2022/08/02

The Photo Please refer to Antenna Test Photo

# Test procedure

- ❑ The very common “gain comparison” method is used to measure the antenna gain in full anechoic chamber which contains the receiving and transmitting antennas
- ❑ The method requires an antenna which gain is exactly known (called gain standard).
- ❑ Two measurements are performed in receiving mode in the whole sphere in both vertical and horizontal polarizations:
  - ✓ the reference antenna is first measured, providing the received power  $P_0$
  - ✓ and secondly the test antenna, providing the received power  $P_{AUT}$
  - ✓ both antennas are placed exactly in the same arrangement.
- ❑ Then the formulae below are applied to calculate the gain:

$$G_{AUT \text{ dB}} + G_0 \text{ dB} = 20 \log_{10} \left( \frac{4\pi R}{\lambda} \right) + 10 \log_{10} \left( \frac{P_{AUT}}{P_0} \right)$$

$$G_{GS \text{ dB}} + G_0 \text{ dB} = 20 \log_{10} \left( \frac{4\pi R}{\lambda} \right) + 10 \log_{10} \left( \frac{P_{GS}}{P_0} \right)$$

$$G_{AUT \text{ dB}} = G_{GS \text{ dB}} + 10 \cdot \log_{10} \left( \frac{P_{AUT}}{P_{GS}} \right).$$

Where:

$G_{AUT}$  is the gain of the test antenna

$G_{GS}$  is the gain of the gain standard

$G_0$  is the gain of the transmitting antenna

$R$  is the distance between the receiving and transmitting antennas

$\lambda$  is the wavelength

# Antenna gain pattern @2,4GHz

Horizontal plane

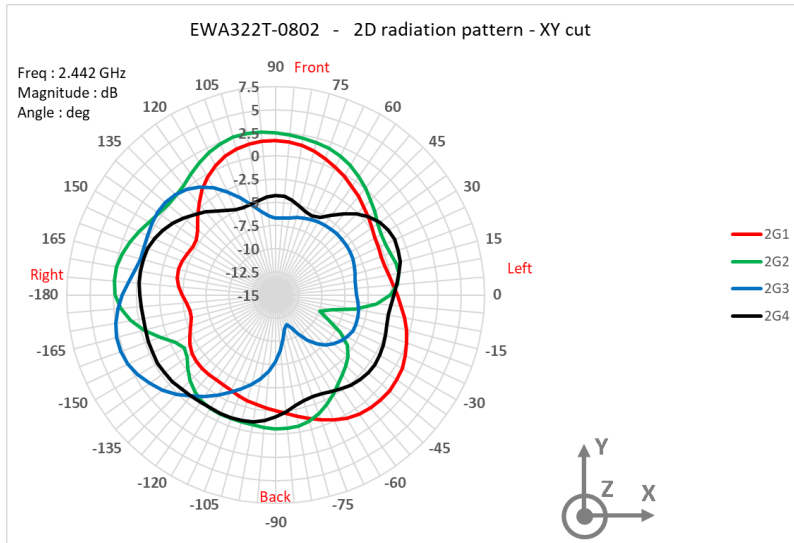

Vertical plane (right/left)

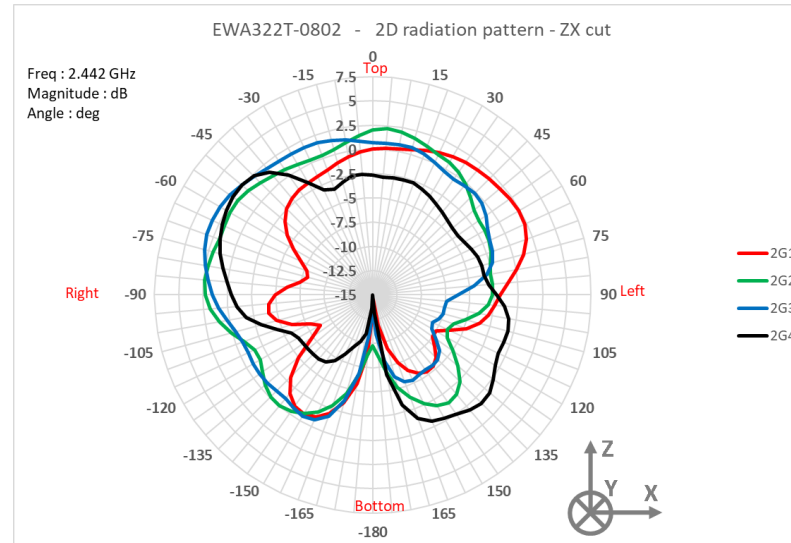

Vertical plane (front/back)

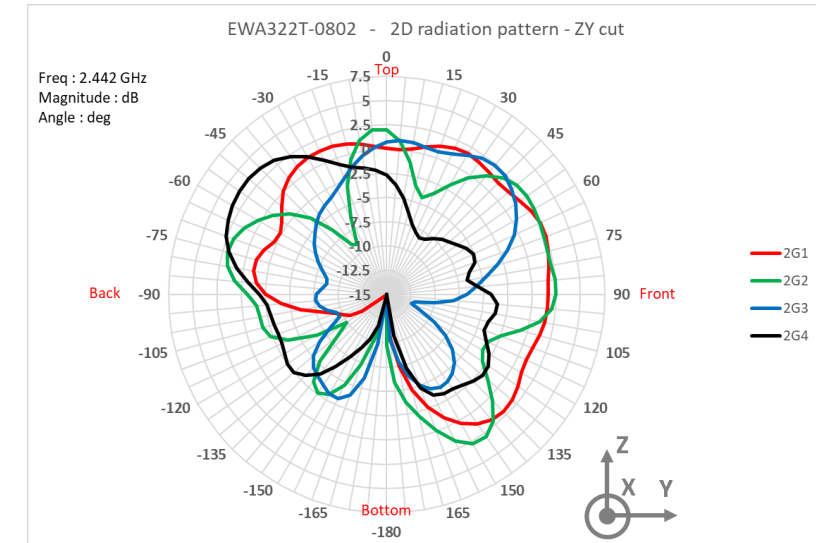

# Antenna gain pattern @5,49GHz

Horizontal plane

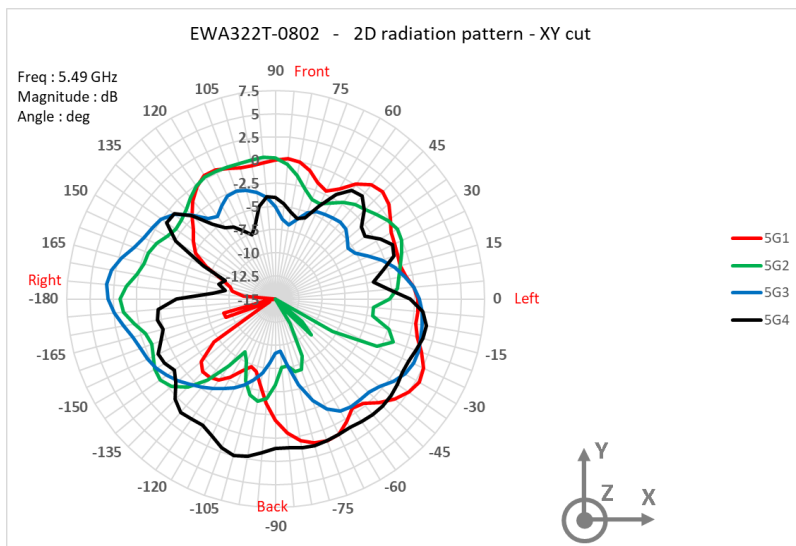

Vertical plane (right/left)

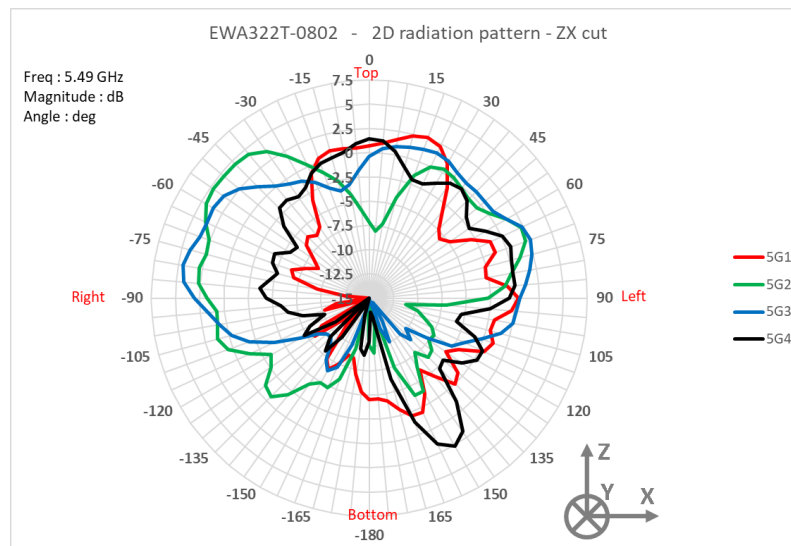

Vertical plane (front/back)

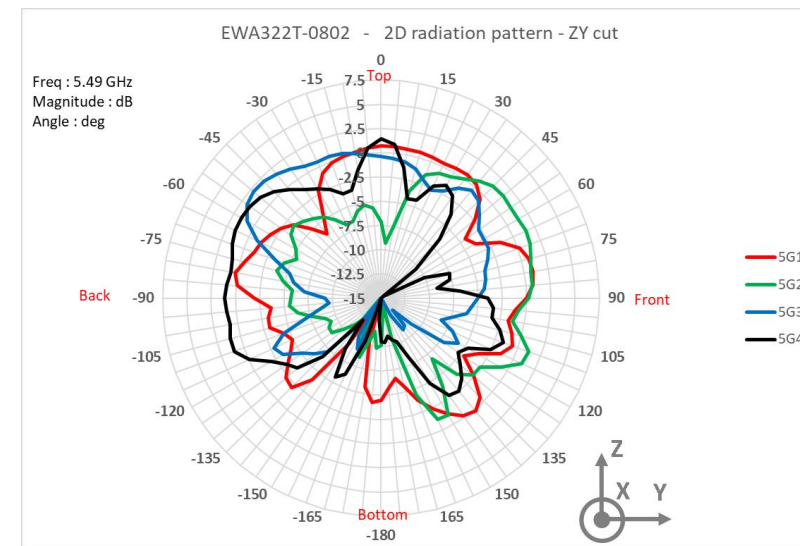

# Antenna gain pattern @6,295GHz

Horizontal plane

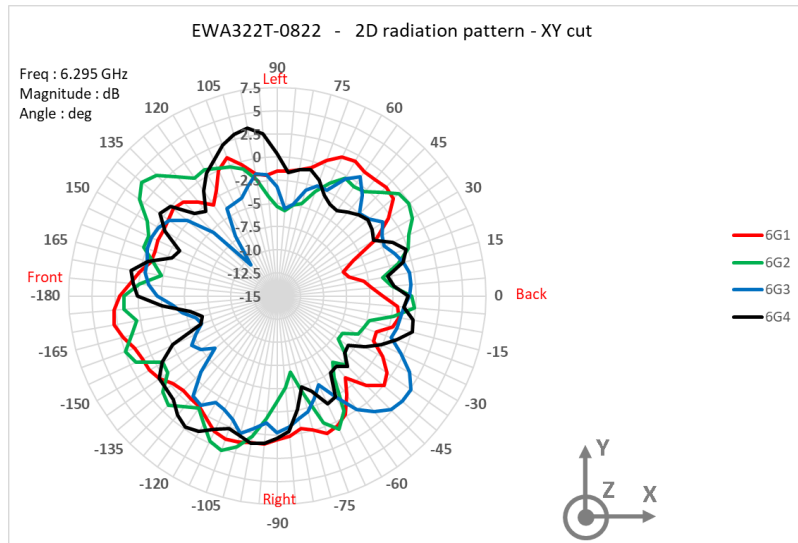

Vertical plane (right/left)

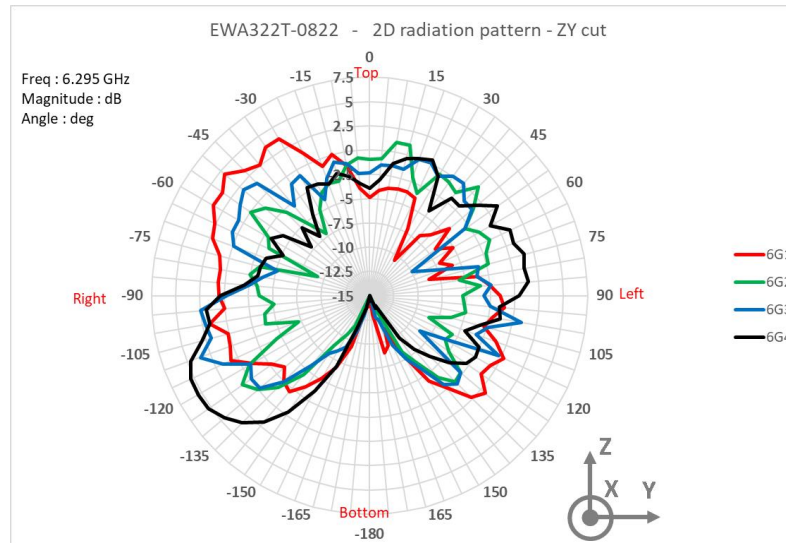

Vertical plane (front/back)

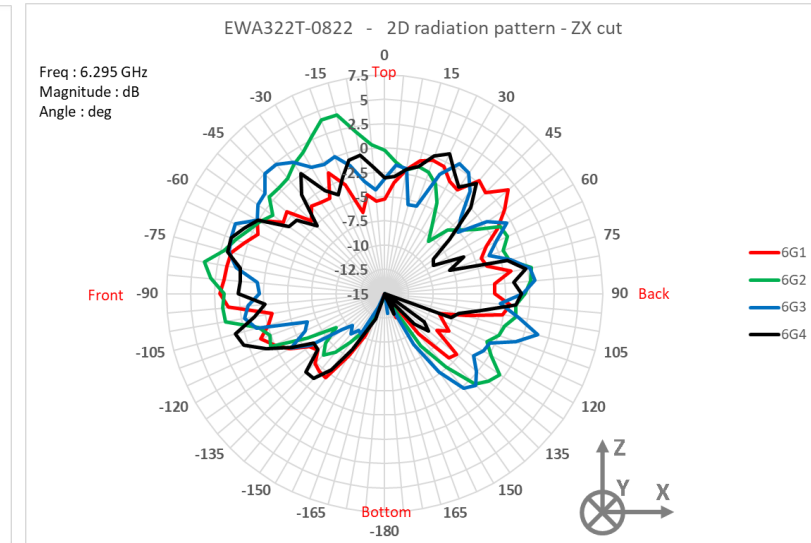

# Antennae gains

Dual band antenna Gain (dBi)										
Frequency (MHz)	2400-2483.5	5170	5250	5330	5490	5600	5730	5735	5815	5835
DB1	3,92	5,61	4,91	4,88	5,34	5,45	5,07	5,16	5,28	5,47
DB2	3,49	5,96	5,65	5,77	5,65	5,91	5,53	5,24	4,79	4,8
DB3	4,18	4,21	4,21	4,13	4,71	4,81	4,8	4,63	4,24	4,11
DB4	4,52	3,96	3,51	4,18	2,75	4,06	3,61	3,68	3,86	3,75

6GHz antenna Gain (dBi)																
Frequency (MHz)	5925	5945	6055	6175	6295	6425	6475	6525	6615	6695	6775	6875	6955	6995	7035	7125
6G1	5,52	5,61	5,42	5,19	5,83	5,31	5,14	5,17	4,94	4,9	4,78	4,55	5,34	5,48	5,18	5,14
6G2	4,15	4,16	4,62	4,82	5,15	5,38	4,85	4,42	5,01	4,86	5,64	5,45	4,62	4,55	4,93	5,51
6G3	5,68	5,63	4,94	4,69	5,34	5,56	5,48	4,94	4,44	5,21	4,49	5,76	5,22	5,05	4,93	5,09
6G4	5,57	5,72	5,35	6,08	5,67	6,27	6	6,15	5,78	5,85	6,16	5,79	4,84	4,78	4,87	5,23

# versions

2022-09-01 v1: Initial release. Arnaud Goblet.

2023-02-03 v2: added radiation patterns, product and manufacturer information. AG

2023-06-07 v3: Add information on test environment and setup (page 8-10)

2023-06-08 v4: Add information on test SW and list of test equipment (page 8-9)

2023-06-15 v5: update the equipment calibration dates (page 8-9), highlight test personnel name (page 10), add test procedure (page 11)